



**THE DATASHEET OF
LTM4643IY#PBF**



LTPowerCAD™ II

Introduction & Quick Start

Rev

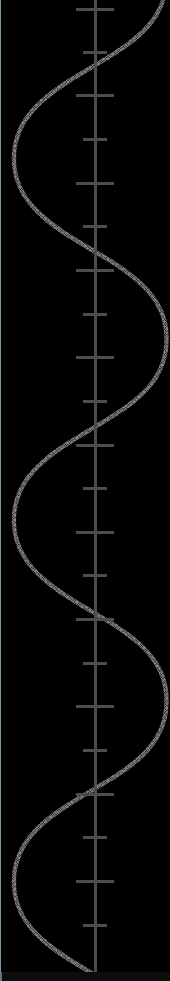
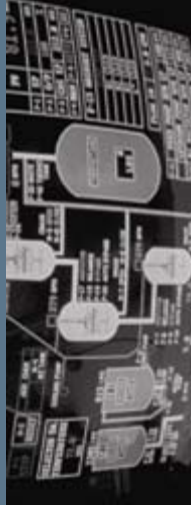

Design Tool Development Team
Power Products, Linear Technology Corp.
LTPowerCAD@Linear.com



Copyright © 2013 Linear Technology. All rights reserved

What is LTpowerCAD Design Tool

A Complete, Step-by-Step Power Supply Design Tool:



Step-by-Step Power Supply Design:

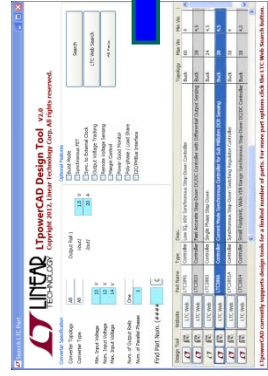

Enter specs,
search solution.

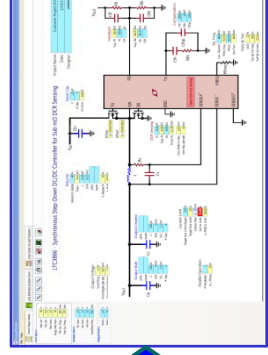

Power Supply
Schematic.

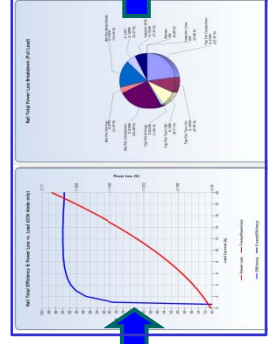

Efficiency &
Power Loss

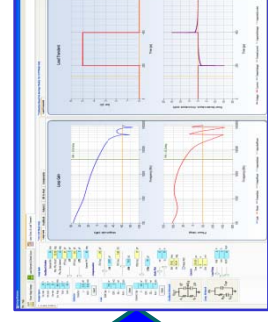

Loop Stability
& Transient

LTpowerCAD

How is LTpowerCAD Different from LTspice:

LTspice: A powerful circuit **simulation tool** with integrated models for Linear Technology products.

LTpowerCAD Design Tool :

- A power supply **design tool** instead of **simulation tool**.
- **Searches for a solution** / LTC part for given power supply.
- Guides users to **select power stage components**.
- Provides detailed **power efficiency / loss** analysis.
- Provide quick **loop bode plot** stability and load transient analysis.
- Only supports **selected power products** (mostly buck & boost converters).
- Design file can be exported into LTspice simulation circuit.

How to get your free *LTpowerCAD II*

- Go to <http://www.linear.com/LTpowerCAD>
- Download & install **LTpowerCAD II** on your Windows PC
- See later pages for installation instruction.

Buck

Buck Converters :

Green Cell Background - Excel tool available
Red Cell Background - LTpowerCAD Non-Excel Tool available
Bold - Polyphase single output compatible

Green Cell Background - Excel tool available
Red Cell Background - LTpowerCAD Non-Excel Tool available
Bold - Polyphase single output compatible

Controller

3-output	2-output	1 output
	LTC3838	LTC3829
	LTC3838-1	LTC3833
	LTC3838-2	LTC3839
	LTC3850	LTC3851A
	LTC3855	LTC3854
	LTC3857	LTC3856
	LTC3857-1	LTC3866
	LTC3858	LTC3883
	LTC3858-1	LTC3883
	LTC3858-2	
	LTC3869	LTC3864
	LTC3869-2	LTC3891
	LTC3880	
	LTC3890	
	LTC3890-1	

Monolithic

3-output	2-output	1-output
	LTC3615	LTC3600
	LTC3615(CH1)	LTC3601
	LTC3615(CH2)	LTC3602
	LTC3633	LTC3603
	LTC3633A	LTC3604
	LTC3633A-1	LTC3605
	LTC3633A-2	LTC3605A
	LTC3633A-3	LTC3415
	LTC3407(CH1)	LTC3405A-1.375
	LTC3407(CH2)	LTC3405A-1.5
	LTC3407-2(CH1)	LTC3405A-1.8
	LTC3407-2(CH2)	LTC3608
	LTC3407-2(CH2)	LTC3609
	LTC3407-2(CH2)	LTC3610
	LTC3407-	LTC3611
	LTC3407-	LTC3612
	LTC3407-4(CH1)	LTC3614
	LTC3407-4(CH2)	LTC3616
	LTC3417(CH1)	LTC3613
	LTC3417(CH2)	LTC3646
	LTC3417A(CH1)	LTC3646-1
	LTC3417A(CH2)	
	LTC3417A-	LTC3409
	LTC3417A-	LTC3409A
	LTC3419(CH1)	LTC3410
	LTC3419(CH2)	LTC3410-1.2
	LTC3547(CH1)	LTC3410-1.65
	LTC3547(CH2)	LTC3410-1.875
		LTC34108
		LTC3411
		LTC3411A
		LTC3412
		LTC3412A
		LTC3413
		LTC3414
		LTC3416
		LTC3549
		LTC3561
		LTC3568

µModule Regulator

3-output	2-output
	LTM3976
	LTM3990
	LTM3991
	LTM3403
	LTM3404
	LTM3405
	LTM3405A
	LTC3405A-1.375
	LTC3405A-1.5
	LTC3405A-1.8
	LTC3406/3406B
	LTC3406-1.2
	LTC3406-1.5
	LTC3406-1.8
	LTC3406A
	LTC3406AB
	LTC3406AB-2
	LTC3406B-1.2
	LTC3406B-2
	LTC3409
	LTC3409A
	LTC3410
	LTC3410-1.2
	LTC3410-1.65
	LTC3410-1.875
	LTC34108
	LTC3411
	LTC3411A
	LTC3412
	LTC3412A
	LTC3413
	LTC3414
	LTC3416
	LTC3549
	LTC3561
	LTC3568

Note:

This list was generated on 07/25/2013. **New parts** could be added to the library after that. Click "**Sync-Release**" to update LTpowerCAD library & functions.

Boost Converters :

Boost
Polyphase (Bold)

Green Cell Background - Excel tool available
Red Cell Background - LTpowerCAD Non-Excel Tool available
Bold - Polyphase single output compatible

Updated:

Controller

Monolithic

µModule Regulator®

3-output	2-output	1-output
LTC3788	LTC3787 LTC3862 LTC3786	

3-output	2-output	1-output

3-output	2-output

Buck-Boost
Polyphase (Bold)

Green Cell Background - Excel tool available
Red Cell Background - LTpowerCAD Non-Excel Tool available
Bold - Polyphase single output compatible

Updated:

Controller

Monolithic

µModule Regulator®

3-output	2-output	1-output

3-output	2-output	1-output

3-output	2-output

Note:

This list was generated on 06/06/2013. **New parts** could be added to the library after that. Click “**Sync-Release**” to update LTpowerCAD library & functions.

I. Installation

LTpowerCAD II

Software Installation

Minimum Requirements

The following system and software is required for LTpowerCAD

- ✓ PC with **Microsoft Windows XP SP2** or later OS
- ✓ **Microsoft Office Excel 2000, 2003, 2007, 2010** or 2013
- ✓ **Microsoft .NET Framework 3.5 SP1, 4.0** or Higher
<http://www.microsoft.com/net/download>
- ✓ **Microsoft SQL Server Compact 3.5 Service Pack 2**
<http://www.microsoft.com/en-us/download/details.aspx?id=5783>

* Note : The LTpowerCAD installer is made to **automatically download and install these the Microsoft .NET and SQL Server** to your system if your system does not already have these installed. However, if for some reason they are not installed automatically, you need to install them manually from Microsoft download sites.

****Note:**

- Windows Vista or Windows 7, Windows 8 based PC has .NET Framework integrated.
- Some Windows XP based PC may need additional installation of the .NET Framework, which is freely downloaded at www.microsoft.com.
- Many new computers may already have SQL Server Compact 3.5SP2 installed (check to see if it is installed)

Minimum Requirements (cont'd)

Optional: check if .NET and SQL Server are installed:

Control Panel Home

View installed updates
Turn Windows features on or off

Install a program from the network

Control Panel > Programs > Programs and Features

Uninstall or change a program

To uninstall a program, select it from the list and then click Uninstall, Change, or Repair.

Name	Publisher	Installed On	Size	Version
Microsoft .NET Framework 4 Client Profile	Microsoft Corporation	6/14/2010	38.8 MB	4.0.30319
Microsoft .NET Framework 4 Extended	Microsoft Corporation	6/14/2010	51.9 MB	4.0.30319
Microsoft .NET Framework 4 Multi-Targeting Pack	Microsoft Corporation	6/14/2010	83.4 MB	4.0.30319
Microsoft ASP.NET MVC 2	Microsoft Corporation	6/15/2010	482 KB	2.0.50717.0
Microsoft ASP.NET MVC 2 - Visual Studio 2010 Tools	Microsoft Corporation	6/15/2010	2.25 MB	2.0.50717.0
Microsoft Expression Blend 3 SDK	Microsoft Corporation	1/18/2011	8.71 MB	1.0.1343.0
Microsoft Expression Blend 4	Microsoft Corporation	1/18/2011	4.0.20525.0	4.0.20525.0
Microsoft Expression Blend SDK for .NET 4	Microsoft Corporation	1/18/2011	9.70 MB	2.0.20525.0
Microsoft Expression Blend SDK for Silverlight 4	Microsoft Corporation	1/18/2011	11.1 MB	2.0.20525.0
Microsoft Expression Design 4	Microsoft Corporation	1/18/2011	7.0.20516.0	7.0.20516.0
Microsoft Expression Encoder 4 Pro	Microsoft Corporation	1/18/2011	4.0.1639.0	4.0.1639.0
Microsoft Expression Encoder 4 Screen Capture Codec	Microsoft Corporation	1/18/2011	675 KB	4.0.20525.0
Microsoft Expression Studio 4	Microsoft Corporation	1/18/2011	4.0.20525.0	4.0.20525.0
Microsoft Expression Web 4	Microsoft Corporation	1/18/2011	4.0.1165.0	4.0.1165.0
Microsoft Help Viewer 1.0	Microsoft Corporation	6/15/2010	1.0.30319	1.0.30319
Microsoft IntelliPoint 8.2	Microsoft Corporation	9/26/2011	8.20.468.0	8.20.468.0
Microsoft IntelliType Pro 8.2	Microsoft Corporation	9/27/2011	8.20.469.0	8.20.469.0
Microsoft Office Enterprise 2007	Microsoft Corporation	6/18/2010	12.0.6425.1000	12.0.6425.1000
Microsoft Silverlight	Microsoft Corporation	3/1/2012	218 MB	4.1.10111.0
Microsoft Silverlight 3 SDK	Microsoft Corporation	6/15/2010	31.9 MB	3.0.40818.0
Microsoft Silverlight 4 SDK	Microsoft Corporation	1/18/2011	51.5 MB	4.0.50401.0
Microsoft SQL Server 2008 (64-bit)	Microsoft Corporation	6/15/2010	7.94 MB	10.1.2531.0
Microsoft SQL Server 2008 Browser	Microsoft Corporation	6/15/2010	6.37 MB	10.1.2531.0
Microsoft SQL Server 2008 Native Client	Microsoft Corporation	6/15/2010	330 KB	10.50.1447.4
Microsoft SQL Server 2008 R2 Data-Tier Application F...	Microsoft Corporation	6/15/2010	11.8 MB	10.50.1447.4
Microsoft SQL Server 2008 R2 Data-Tier Application P...	Microsoft Corporation	6/15/2010	15.3 MB	10.50.1447.4
Microsoft SQL Server 2008 R2 Management Objects	Microsoft Corporation	6/15/2010	10.1 MB	10.50.1447.4
Microsoft SQL Server 2008 R2 Management Objects (...)	Microsoft Corporation	6/15/2010	5.34 MB	10.50.1447.4
Microsoft SQL Server 2008 R2 Transact-SQL Language...	Microsoft Corporation	6/15/2010	39.4 MB	10.1.2731.0
Microsoft SQL Server 2008 Setup Support Files	Microsoft Corporation	6/15/2010	3.94 MB	10.1.2731.0
Microsoft SQL Server Compact 3.5 SP2 ENU	Microsoft Corporation	6/15/2010	1.51 MB	3.5.8080.0
Microsoft SQL Server Compact 3.5 SP2, 64-bit ENU	Microsoft Corporation	6/15/2010	1.51 MB	3.5.8080.0
Microsoft SQL Server Database Publishing Wizard 1.4	Microsoft Corporation	6/15/2010	10.1 MB	10.1.2531.28
Microsoft SQL Server System CLR Types	Microsoft Corporation	6/15/2010	2.52 MB	10.50.1447.4
Microsoft SQL Server System CLR Types (x64)	Microsoft Corporation	6/15/2010	848 KB	10.50.1447.4
Microsoft SQL Server VSS Writer	Microsoft Corporation	6/15/2010	3.59 MB	10.1.2531.0
Microsoft Sync Framework Runtime v1.0 SP1 (x64)	Microsoft Corporation	6/15/2010	1.00 MB	1.0.3010.0
Microsoft Sync Framework SDK v1.0 SP1	Microsoft Corporation	6/15/2010	29.6 MB	1.0.3010.0
Microsoft Sync Framework Services v1.0 SP1 (x64)	Microsoft Corporation	6/15/2010	2.84 MB	1.0.3010.0
Microsoft Sync Services for ADO.NET v2.0 SP1 (x64)	Microsoft Corporation	6/15/2010	2.84 MB	1.0.3010.0
Microsoft Team Foundation Server 2010 Object Mod...	Microsoft Corporation	6/14/2010	541 KB	2.0.30319
Microsoft Visual C++ 2005 Redistributable	Microsoft Corporation	7/6/2011	346 KB	8.0.59193
Microsoft Visual C++ 2008 Redistributable - x64 9.0.3...	Microsoft Corporation	6/1/2012	788 KB	9.0.30729.4148
Microsoft Visual C++ 2008 Redistributable - x64 9.0.2...	Microsoft Corporation	6/1/2012	793 KB	9.0.30729.4148

Microsoft Corporation Product version: 3.5.8080.0 Size: 3.39 MB

Help link: <http://go.microsoft.com...>

Installing LTPowerCAD II v2.0™

1. Double Click “**Setup.exe**” to Start LTPowerCAD II v2.0™ Design Tool Setup Wizard

Note : Do not install by double clicking the “MS.msi” file as this will prevent the installer from checking to insure missing Microsoft requirements.

2. Click “**Next**”

3. Select Installation Folder and Click “**Next**”

4. Click “**Next**” to Confirm Installation and then “**Close**” to complete the Installation

Click “Next”

Select Folder

Click “Next”

Click “Next”



5. Check the contents of the installation folder (see next slide)

Note : The installation will place shortcuts to the LTPowerCAD II v2.0

II. User Interface

Getting Start with LTpowerCAD II

Main Page



The screenshot shows the main page of the LTpowerCAD II v2.0 software. The interface features a top navigation bar with several buttons. Yellow arrows point from descriptive text to these buttons:

- Start New Design**: Search for a part based on supply spec. and requirements
- Open Existing Design**: Open an existing LTpowerCAD II design file
- Help**: Open an existing Excel-Based design file
- LTC Sales Contacts**: View help file
- LTC Toolbox**: View LTC Sales Office contacts
- Sync Release**: Open LTC Toolbox

At the bottom of the page, there is a section for **Update LTpowerCAD II program & program library**.

LTpowerCAD II Design Tool v2.0
Copyright 2013, Linear Technology Corp. All rights reserved.



Step 1. Enter power supply spec. and required functions.

If you know the LT part# to use, you can enter the 4-digit part# and click "go" instead of search.

Step 3. Select a Part from Search Results Table:

Click LTC icon for LTPowerCAD II tool

Click Excel icon for Excel-Based tool

Note: if the icon is in grey color, it means the design tool is not available.

LINEAR TECHNOLOGY **LTPowerCAD Design Tool v2.0 Beta2 (For Internal Use Only)** Copyright 2012, Linear Technology Corp. All rights reserved.

Optional Features:
 Burst Mode
 Synchronous FET
 Sync. to External Clock
 Output Voltage Tracking
 Remote Voltage Sensing
 Margin Control
 Power Good Monitor
 Poly-phase / Load Share
 I2C/PMBus Interface

Output Rail 1
Vout1: 1.2 V
Iout1: 5 A

Converter Specification
Converter Topology: All
Converter Type: All
Min. Input Voltage: 10.8 V
Nom. Input Voltage: 12 V
Max. Input Voltage: 13.2 V
Num. of Output Rails: One
Num. of Parallel Phases: 1

Find Part Num. (####)

Design Tool	Website	Part Name	Type	Desc.
	LTC Web	LTM4612	uModule	Ultralow Noise 36VIN, 15VOUT, 5A, DC/DC uModule Regulator
	LTC Web	LTM4603	uModule	6A DC/DC uModule Regulator with PLL, Output Tracking and Margining
	LTC Web	LTM4602HV	uModule	6A, 28VIN High Efficiency DC/DC uModule Regulator
	LTC Web	LTM4602	uModule	6A High Efficiency DC/DC uModule Regulator
	LTC Web	LTM4618	uModule	6A DC/DC uModule Regulator with Tracking and Frequency Synchronization
	LTC Web	LTM4606	uModule	Ultralow EMI 28VIN, 6A DC/DC uModule Regulator
	LTC Web	LTM4603-1	uModule	6A DC/DC uModule Regulator
	LTC Web	LTM4603HV	uModule	6A, 28VIN DC/DC uModule Regulator with PLL, Output Tracking and Margining
	LTC Web	LTM4613	uModule	EN55022B Compliant 36VIN, 15VOUT, 8A, DC/DC uModule Regulator
	LTC Web	LTM4600HV	uModule	10A, 28VIN High Efficiency DC/DC uModule Regulator
	LTC Web	LTM4607	uModule	36VIN, 24VOUT High Efficiency Buck-Boost DC/DC uModule Regulator
	LTC Web	LTM4609	uModule	36VIN, 34VOUT High Efficiency Buck-Boost DC/DC uModule Regulator

LTPowerCAD currently supports design tools for a limited number of parts. For more part options click the LTC Web Search

Two possible design tool formats:

1. Non-Excel LTPowerCAD Design Tool:

If available, an active LTC button is shown:



2. Excel-Based Design Tool:

If available, an active Excel button is shown:



Note: if the icon is in grey color, it means the design tool is not available yet.

Search LTC Part



LTPowerCAD Design Tool V2.0 Beta2 (For Internal F
Copyright 2012, Linear Technology Corp. All rights reserved.

Converter Specification

Converter Topology

Converter Type

Min. Input Voltage

Nom. Input Voltage

Max. Input Voltage

Num. of Output Rails

Num. of Parallel Phases

Find Part Num. (####)

Go

Output Rail 1

Vout1

Iout1

1.2 V

5 A

Optional Features

Burst Mode

Synchronous FET

Sync. to External Clock

Output Voltage Tracking

Remote Voltage Sensing

Margin Control

Power Good Monitor

Poly-phase / Load Share

I2C/PMBus Interface

Design Tool	Website	Part Name	Type	Desc.
	LTC Web	LTM4612	uModule	Ultralow Noise 36VIN, 15VOUT, 5A, DC/DC uModule Regulator
	LTC Web	LTM4603	uModule	6A DC/DC uModule Regulator with PLL, Output Tracking and Margining
	LTC Web	LTM4602HV	uModule	6A, 28VIN High Efficiency DC/DC uModule Regulator
	LTC Web	LTM4602	uModule	6A High Efficiency DC/DC uModule Regulator
	LTC Web	LTM4618	uModule	6A DC/DC uModule Regulator with Tracking and Frequency Synchronization
	LTC Web	LTM4606	uModule	Ultralow EMI 28VIN, 6A DC/DC uModule Regulator
	LTC Web	LTM4603-1	uModule	6A DC/DC uModule Regulator
	LTC Web	LTM4603HV	uModule	6A, 28VIN DC/DC uModule Regulator with PLL, Output Tracking and Margining
	LTC Web	LTM4613	uModule	EN55022B Compliant 36VIN, 15VOUT, 8A, DC/DC uModule Regulator
	LTC Web	LTM4600HV	uModule	10A, 28VIN High Efficiency DC/DC uModule Regulator
	LTC Web	LTM4607	uModule	36VIN, 24VOUT High Efficiency Buck-Boost DC/DC uModule Regulator
	LTC Web	LTM4609	uModule	36VIN, 34VOUT High Efficiency Buck-Boost DC/DC uModule Regulator

LTPowerCAD currently supports design tools for a limited number of parts. For more part options click the LTC Web Search

Step-By-Step Supply Design Process

using the LTpowerCAD™ Design Process

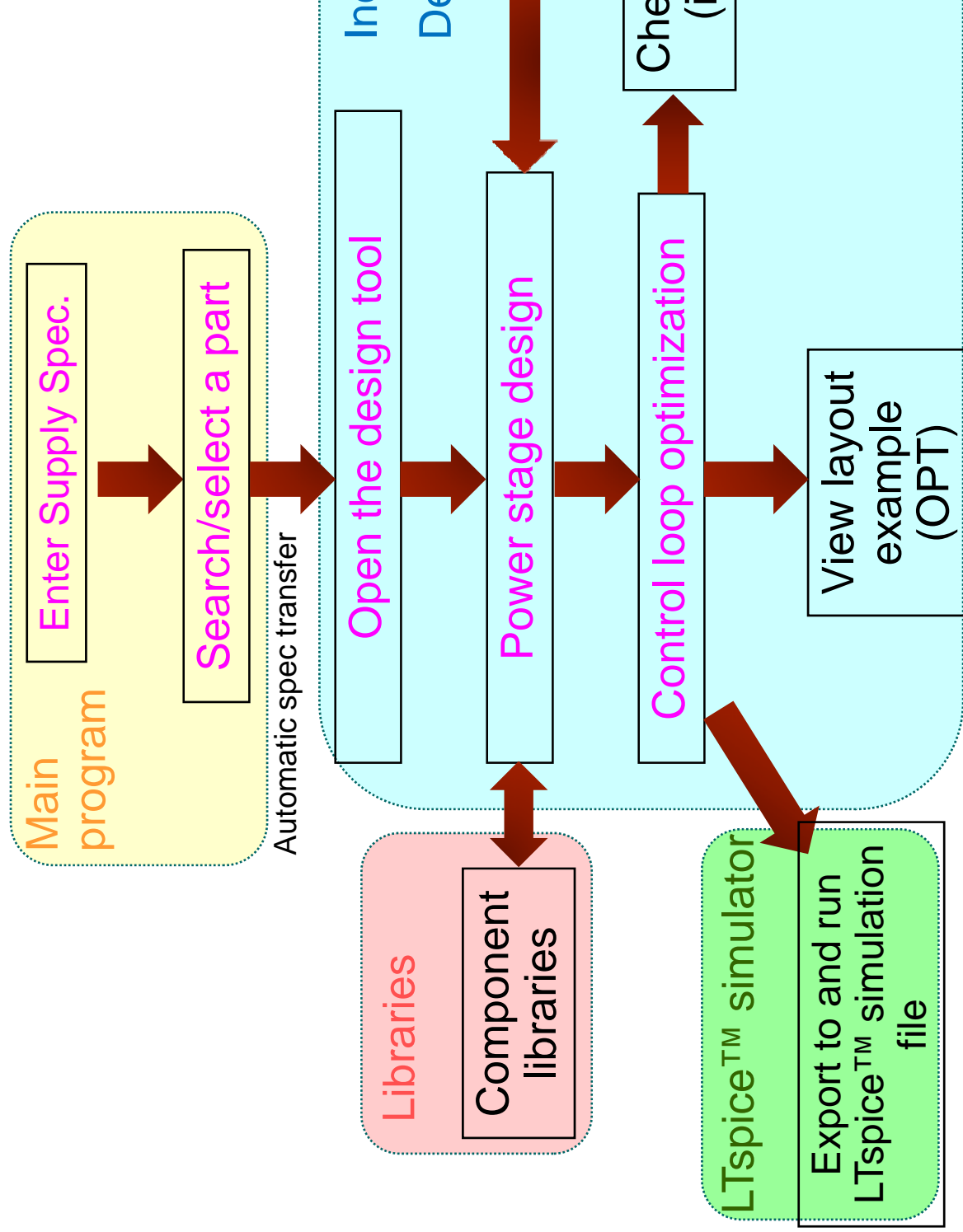



Example of a non-Excel **LTpowerCAD** d Tool

Design Step 1 – Power Stage Design

Yellow Cells = Suggested values or calculated parameters

Blue Cells = User's chosen values

Design Requirements & Part Limits

LTC3838 - Dual, Fast, Accurate Step-Down DC/DC Controller with Differential Output Sensing

Project Name: _____ Date: _____ Designer: _____

Design Specs

Max Vin:	38 V
Min Vin:	4.5 V
Max Vout:	5.5 V
Sugg. Max. Iout:	30 A
Min Sw. Freq.:	200 kHz
Max Sw. Freq.:	2000 kHz

Output Voltage

Vout,prog:	1.2 V
Vout,ripple (p-p):	19 mV
ΔVout/Vout,ripple:	1.6 %

Output Rail 1

Vout1:	1.2 V
Iout1:	10 A

Output Rail 2

Vout2:	1.8 V
Iout2:	8 A

Current Limit

Target Iout Limit Margin:	150 %
Target Iout Limit:	15 A
I_L,pk@ Target Iout Limit:	15.95 A
I_L,V@ Target Iout Limit:	14.05 A

Inductor

Desired I_L,ripple:	40 %
Sug. L1:	0.71 μH
L1:	1.5 μH
DCR:	10.4 mΩ

Output Ceramic

MFR:	
Part #:	
C:	10 μF
ESR:	3 mΩ
ESL:	2 nH
# Cap:	1

Output Bulk

MFR:	
Part #:	
C:	330 μF
ESR:	9 mΩ
ESL:	2 nH
# Cap:	1

DCR Current Sensing

Actual I_RMS:	15.9 A
I_L,PK@ Iout Limit:	15.9 A
I_L,V@ Iout Limit:	14.1 mV
Vout1_V@ Iout Max:	59 mV
Vout1_Rip (pk-pk):	15.1 mV

DCR Current Sensing

Actual I_RMS:	14.2 A
I_L,PK@ Iout Limit:	14.2 A
I_L,V@ Iout Limit:	63.8 mV
Vout2_V@ Iout Max:	42.7 mV
Vout2_Rip (pk-pk):	11.1 mV

Compensation

Sw. Freq.:	500 kHz
Defined Fm:	80.9 kHz
RT Sup:	110 kΩ
Act. Fm:	370 kHz

Duty & Ton

Voutd Duty:	18 %
Ton @ Vin Max:	324 ns
Ton @ Vin Min:	1730 ns

Feedback

Sup. Rf1:	60.4 kΩ
Rf1:	60.4 kΩ
Cf1:	PF

Compensation

Ch1:	220 pF
Rh1:	315 kΩ
Rb1:	315 kΩ

Compensation

Ch2:	2200 pF
Rh2:	315 kΩ
Rb2:	315 kΩ

Duty & Ton

Voutd Duty:	18 %
Ton @ Vin Max:	324 ns
Ton @ Vin Min:	1730 ns

Select Sense Setting

See Loop Comp & Load Transient Tab For Details

- User can only change blue-cell values and check calculated circuit parameters in yellow
- Red cells are for warnings. User needs to decide if following/correcting the warning or

Design Step 2– Select L and FET, Optimize Eff % & Po

View data for each rail

Enter power stage component details & Test Conditions (enter manually or select

The screenshot displays the LTpowerCAD II v2.0 software interface. The top menu bar includes File, Help, Power Stage Design, Loss Estimate & Break Down, Loop Comp. & Load Transient, and Freeze Plots. The main workspace is divided into several sections:

- Design Specs:** Vin max: 15 V, Vin nom: 10 V, Vin min: 5 V, Sw. Freq: 370 kHz, Iout: 10 A, Vout: 1.2 V.
- Inductor:** L: 1.5 uH, DCR: 10.4 mΩ.
- Inductor Properties:** Vendor: Fairchild, Part: FDM57578, Vds: 25 V, Qg: 1.7 nC, Qgs: 3.7 nC, Rg: 1.2 Ω, Vmiller: 2.9 V, Vdiode: 0.83 V, Ploss: 0.194 W (Each FET), θj-c: 1°C/W, ΔTj-x: °C.
- Bottom MOSFET Q1:** Vendor: Fairchild, Part: FDM5558E, Vds: 25 V, Qg: 38 nC, Qgs: 10 nC, Rg: 0.9 Ω, Vmiller: 2.1 V, Vdiode: 0.6 V, Ploss: 0.196 W (Each FET), θj-c: 1°C/W, ΔTj-x: °C.
- Extensive Plots:** Includes checkboxes for Freeze Plots and Update Plots.
- Summary:** Rail Total Power Loss @ Full Load: Pin: 13.629 W, Pout: 1.2 W, Ploss: 1.629 W, η: 88.05 %.
- Output Rail # 1:** Iout: 4.2 A, Eff: 91 %, Ploss: 0.3 W.

Below the design specs, there are two graphs:

- Rail Total Efficiency & Power Loss vs. Load (CCM Mode only):** A line graph showing Efficiency (%) on the y-axis (50 to 100) and Load Current (A) on the x-axis (0 to 10). A red line represents Power Loss and a blue line represents Efficiency. A vertical dashed yellow line is at 4.2 A.
- Rail Total Power Loss Breakdown:** A pie chart showing the distribution of power loss components: Inductor DCR (1.068W, 65.48%), I.C. LDO (0.08W, 4.90%), and Bot. Fet. Body Diode (0.079W, 4.84%).

Click "Update Plots" after component value changes.

Estimated Efficiency & Power Loss Curves with Data Point Cursors. Double-click to set axes Preferences

Estimated Power Loss Breakdown

Power Component Library - FET

LTpowerCAD II v2.0

File Help Power Stage Design Loss Estimate & Break Down Loop Comp. & Load Transient

Design Specs
 Vin max: 12 V
 Vin nom: 12 V
 Vin min: 12 V
 Sw. Freq: 500 kHz
 Vout: 1 V
 Iout: 20 A

Inductor
 L: 0.3 μ H
 DCR: 1 m Ω

Inductor Loss
 DCR Loss: W
 Core Loss: W
 Total Loss: W

Back

Top MOSFET QT
 Vendor: Fairchild
 Part: FDM5585S
 Vds: 25 V
 Qg: 38 nC
 Rds(on): 1.3 m Ω
 Rg: 0.9 Ω
 Vds: 25 V
 Ploss: W (Each Fet)
 Btjx: $^{\circ}$ C/W
 Δ Tjx: $^{\circ}$ C

Bottom MOSFET QB
 Vendor: Fairchild
 Part: FDM5585S
 Vds: 25 V
 Qg: 38 nC
 Rds(on): 1.3 m Ω
 Rg: 0.9 Ω
 Vds: 25 V
 Ploss: W (Each Fet)
 Btjx: $^{\circ}$ C/W
 Δ Tjx: $^{\circ}$ C

Estimate
 Win: 12 V
 Freeze Plot

External Bias
 EXTVC: V
 Rail Total Power Loss @ Full Load
 Pin: W
 Pout: W
 Ploss: W
 n: %

Curors
 Iout: 0 A
 Eff: 0 %
 Ploss: 0 W

Update Plots

Output Rail # 1

Power MOSFET Library

Filter In Parts: *

Vendor	Part Name	Vds (V)	Rds(on) (m Ω)	Qg (nC)	Qgd (nC)	Qgs (nC)	Rg (Ω)	Vdiode (V)	Vmiller (V)	Vth (V)	Package	Chan
Renesas	RJMG301	30	3	14.5	2	14.5	2	0.84	3	2.5	LFP4K	N
Renesas	RJMG305	30	10	8	1.5	3.6	0.6	0.85	3	2.5	LFP4K	N
Infineon	BSC019N02K	20	1.6	64	11	19	1.90	0.80	1.90	1.0	PG-TDSON	N
Infineon	BSC028N02K	20	2.1	40	7	11.4	1.50	0.85	1.90	1.0	PG-TDSON	N
Infineon	BSC046N02K	20	3.5	21	4	6.5	1.90	0.90	2.10	1.0	PG-TDSON	N
Infineon	BSC010N02L	25	1.1	31	6.8	11	0.60	0.80	2.40	1.6	PG-TDSON	N
Infineon	BSC010N02L	25	1.1	29	6.9	10	0.60	0.56	2.40	1.6	PG-TDSON	N
Infineon	BSC014N02L	25	1.6	18.7	4.7	6.8	0.60	0.56	2.50	1.6	PG-TDSON	N
Infineon	BSC018N02L	25	1.8	19	4.3	7	0.80	0.85	2.50	1.6	PG-TDSON	N
Infineon	BSC0911N0...	25	1.3	25	5.5	8.8	0.60	0.79	2.30	1.6	PG-TDSON	N
Infineon	BSC0911N0...	25	3.7	7.7	1.8	3	0.90	0.84	2.60	1.6	PG-TDSON	N

User Parts:

Vendor	Part Name	Vds (V)	Rds(on) (m Ω)	Qg (nC)	Qgd (nC)	Qgs (nC)	Rg (Ω)	Vdiode (V)	Vmiller (V)	Vth (V)	Package	Chan
Fairchild	FDM5585S	25	1.3	38	9.7	10	0.90	0.60	2.10	1.7	POWER56	N
Fairchild	FDM57278	25	6.3	8	1.7	3.7	1.20	0.83	2.90	2.0	POWER56	N

Add A New User Part:

Vendor	Part Name	Vds (V)	Rds(on) (m Ω)	Qg (nC)	Qgd (nC)	Qgs (nC)	Rg (Ω)	Vdiode (V)	Vmiller (V)	Vth (V)	Package	Chan

Vendor Links

FAIRCHILD SEMICONDUCTOR
 VISHAY
 infineon
 RENE

Click "Select" to open MOSFET lib

Popular vendor weblinks

Power Component Library - Inductor

LTpowerCAD II v2.0

File Help

Power Stage Design

Loop Comp. & Load Transient

Design Specs

Output Ball # 1

Inductor

Inductor Loss

Back

Top MOSFET QT

Bottom MOSFET QB

Estimate

External Bias

Rail Total Power Loss @ Full Load

Cursors

Power INDUCTOR Library

Build-In Parts:

Vendor	Part Name	Inductance (µH)	L Tol. (%)	DCR (mΩ)	DCR Tol. (%)	ISat (A)	L Decrease (%)	IHeat (A)	Temp. Rise (C)	Core
VITEC	59P8903	0.32	10	0.17	10.00	50.00	20.00	80.00	40.00	Ferrite 1
VITEC	59P8904	0.44	10	0.17	10.00	35.00	20.00	80.00	40.00	Ferrite 1
VITEC	59P9873N	0.22	15	0.29	10.00	47.00	20.00	48.00	40.00	Ferrite 1
VITEC	59P9874N	0.30	15	0.29	10.00	34.00	20.00	48.00	40.00	Ferrite 1
VITEC	59P9875N	0.40	15	0.29	10.00	23.00	20.00	48.00	40.00	Ferrite 1
VITEC	59P9876N	0.51	15	0.29	10.00	17.00	20.00	48.00	40.00	Ferrite 1
WURTH	744 301 025	0.22	20	0.32	10.00	65.00	20.00	40.00	50.00	MnZn 1
WURTH	744 301 033	0.33	20	0.32	10.00	46.00	20.00	40.00	50.00	MnZn 1
WURTH	744 301 047	0.47	20	0.32	10.00	35.00	20.00	40.00	50.00	MnZn 1
WURTH	744 304 022	0.22	20	0.17	10.00	23.00	20.00	26.00	50.00	Ferrite 1
WURTH	744 306 030	0.30	20	0.26	10.00	24.00	20.00	26.00	50.00	Ferrite 1

User Parts:

Vendor	Part Name	Inductance (µH)	L Tol. (%)	DCR (mΩ)	DCR Tol. (%)	ISat (A)	L Decrease (%)	IHeat (A)	Temp. Rise (C)	Core
COLCRAFT	SERLE90-333	0.33	20	0.77	20	43	20	16.9	40	Ferrite 1

Add A New User Part:

Vendor	Part Name	Inductance (µH)	L Tol. (%)	DCR (mΩ)	DCR Tol. (%)	ISat (A)	L Decrease (%)	IHeat (A)	Temp. Rise (C)	Core

Vendor Search Tools

Colcraft, VISHAY, VITEC, TDK, murata, sumida

Click "Select" to open inductor library.

Popular vendor weblink / web-search site.

Design Step 3 – Optimize Loop Comp & Load Trans

Enter component details (enter manually or select from built-in library)

View data for each rail

View Loop Gain, Feedback gain, Output Impedance, Control to Output, Compensator

The screenshot displays the LTpowerCAD II v2.0 software interface. The top section shows design specifications for two output rails:

- Output Rail #1:** Vin max: 13.2 V, Vin nom: 12 V, Vin min: 10.8 V, Sw. Freq: 335 kHz, Vout: 1.2 V, Iout: 15 A.
- Output Rail #2:** Vin max: 13.2 V, Vin nom: 12 V, Vin min: 10.8 V, Sw. Freq: 335 kHz, Vout: 1.2 V, Iout: 15 A.

Below the specifications, component values are listed for various parts of the power stage and compensator:

- Feedback Divider:** Desired BW: 66.88 kHz, Max. Pk Boost: 11.54 dB, Pk Boost Desired: 10 dB, CFF Sug: 47 pF.
- Inductor:** Inductor: 1 uH, L: 1 uH, DCR: 3 mΩ.
- Compensation:** Ch Sug: 379 pF, Cw: 2200 pF, Rth Sug: 2 kΩ, Rth: 7.15 kΩ, Cth Sug: 83 pF, Cth: 330 uF, ESR: 9 mΩ, ESL: 2 nH, Num: 1 pcs.
- Feedback Network:** Vin: 12 V, Io: 15 A, BW: 34.67 kHz, PM: 69.78 deg.
- Comp. Network:** High: 7.5 A, Low: 0 A, ΔI/Δt: 10 A/μs.

The bottom section contains two Bode plots:

- Loop Gain:** Magnitude (dB) vs Frequency (Hz). The plot shows a magnitude curve with a bandwidth (BW) of 34.67 kHz.
- Phase:** Phase (deg) vs Frequency (Hz). The plot shows a phase curve with a phase margin (PM) of 69.78 deg.

At the bottom right, there are two time-domain plots:

- Load Transient:** Iout (A) vs Time (ms). The plot shows a step change in load current from 0 A to 15 A.
- Yout Undershoot, Overshoot (mV):** YoutUndershoot (mV) vs Time (ms). The plot shows the output voltage response to the load transient, with a minimum value of approximately -100 mV.

Capacitor library

Loop Gain, Feedback, Output Impedance, Ith to Vout, and Compensator plots

Import plot data from data file (ie Ridley AP300) or Export data to data file or Excel.

Load Transient Estimation

(Optional) Design Step 4 – Export to LTspice for Simulation

LTpowerCAD II v2.0

File Help

Power Stage Design Loop Comp. & Load Transient

Loss Estimate & Break Down

Part Specs

Max Vin:	38 V
Min Vin:	4.5 V
Max Vout:	5.5 V
Sugg. Max Iout:	30 A
Min Sw. Freq.:	200 kHz
Max Sw. Freq.:	2000 kHz

Design Specs

Vin max:	15 V
Vin nom:	10 V
Vin min:	5 V
Switching Freq.:	370 kHz

Output Rail 1

Vout1:	1.2 V
Iout1:	10 A

Output Rail 2

Vout2:	1.8 V
Iout2:	8 A

Current Limit

Target Iout1 Limit (Amp)	15.0 A
I _{pk} @ Target Iout1 Limit	15.85 A
I _{avg} @ Target Iout1 Limit	14.05 A

Output Voltage

Vout1 Peak	1.2 V
Vout1 Ripple (p-p)	19 mV
ΔVout1/Vout1 Ripple	1.6 %

Output Ceramic

MFR	ParPi	C	10 μF
ESR	3 mΩ	ESL	0.8 nH
# Csp			1

Output Bulk

MFR	ParPi	C	330 μF
ESR	9 mΩ	ESL	2 nH
# Csp			1

DCR Current Sens

Act. I _{o1} Limit	8.5 A
LL Pk@I _{o1} Limit	6.59 A
V _{inst} Pk@I _{o1} Max	74.1 mV
V _{inst} V _{avg} @I _{o1} Max	59 mV
V _{inst} Rip. (p-p)	15.1 mV

Duty & Ton

V _{out2} Duty	11 %
Ton1 @ Vin Max	215 ns
Ton1 @ Vin Min	255 ns

Project Name: _____
Date: _____
Designer: _____

LTC3838 - Dual Fast, Accurate Step-Down DC/DC Controller with Differential Output Sensing

File View Plot Settings Simulation Tools Window Help

LTC3838 circuit.raw

LTC3838 circuit.asc

LTC3838 circuit.raw

LTC3838 circuit.asc

LTC3838 circuit.raw

LTC3838 circuit.asc

V(p007)

I(L2)

11V 9V 7V 5V 3V 1V -1V

6.3A 1.4A -3.6A 0ps

0ps 80μs 160μs 240μs 320μs 400μs 480μs 560μs 640μs

Bench Verified Loop and Load Transient

- In the design tool, the model of every part is on LTC standard der
- It remains the user verify his calculated prototype.

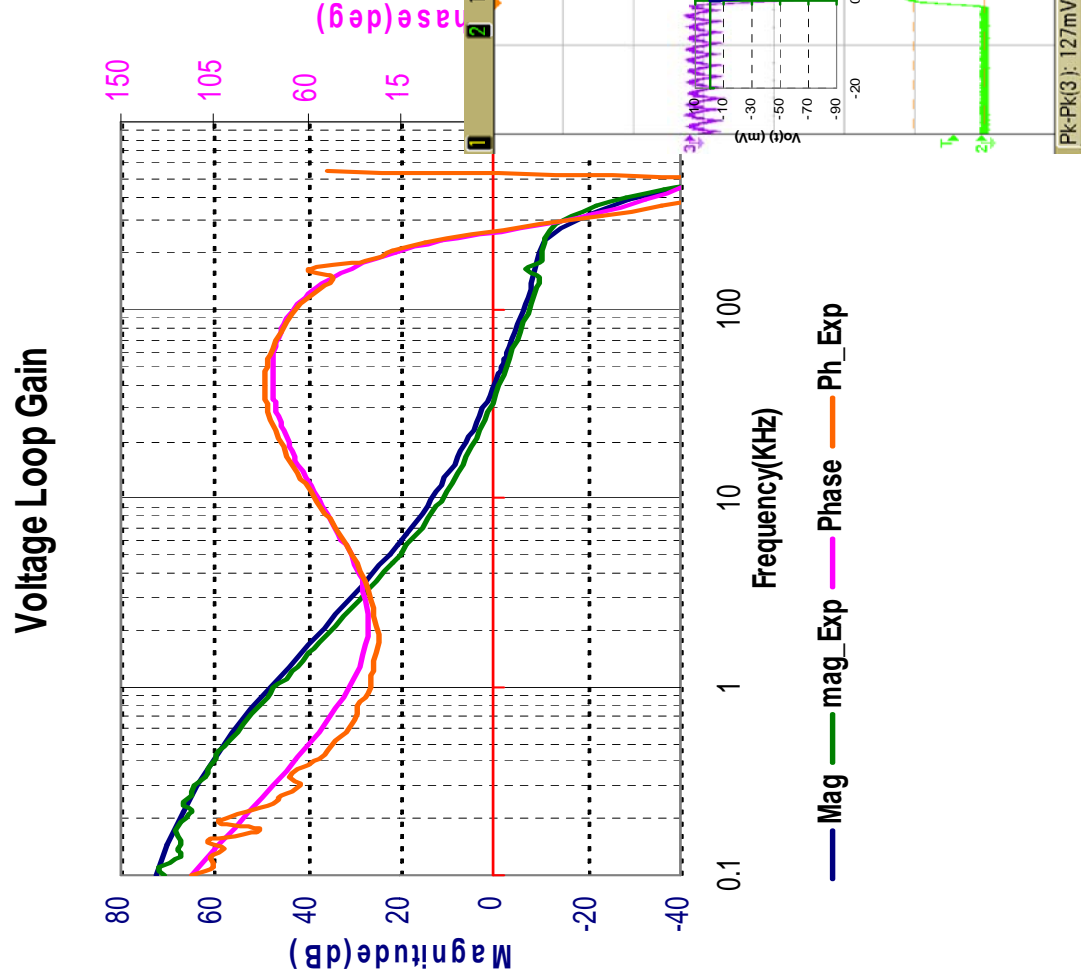



Example of a **Excel-Based** design Tool

Step 1: Power Components Selection

In the design spreadsheet, power components design is guided with schematic interface:

Values in yellow cells are calculated / recommended by design tool

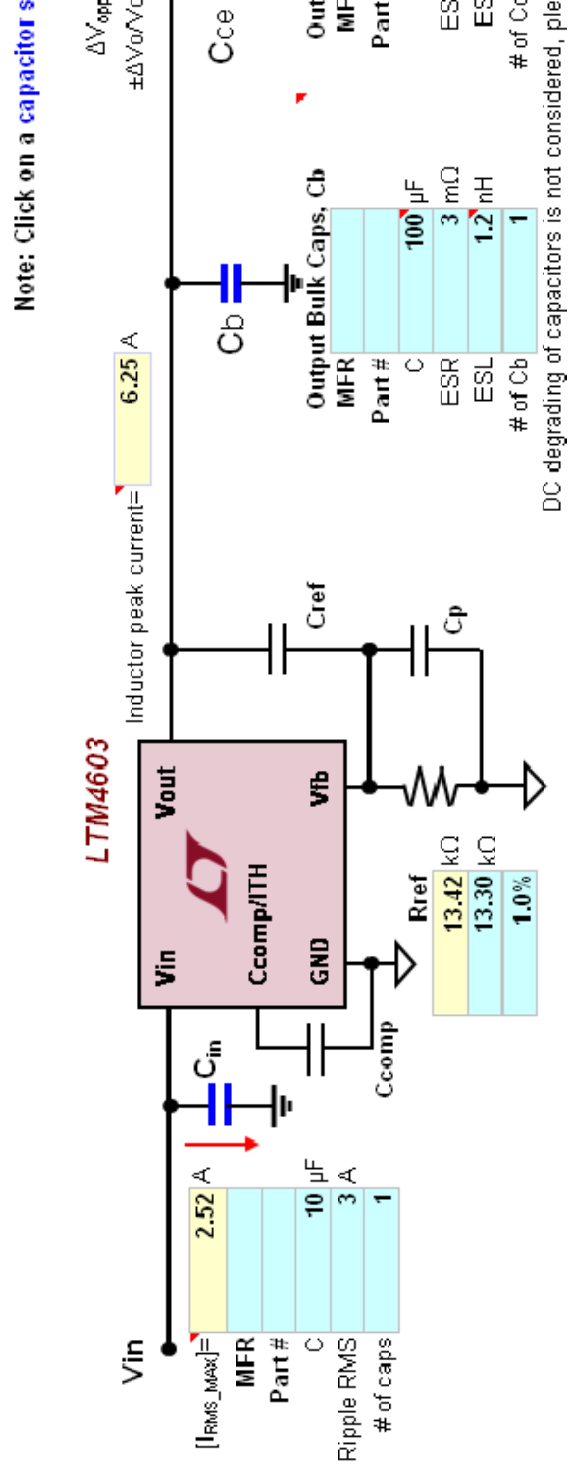

Values in blue / entered

Power Stage Performances

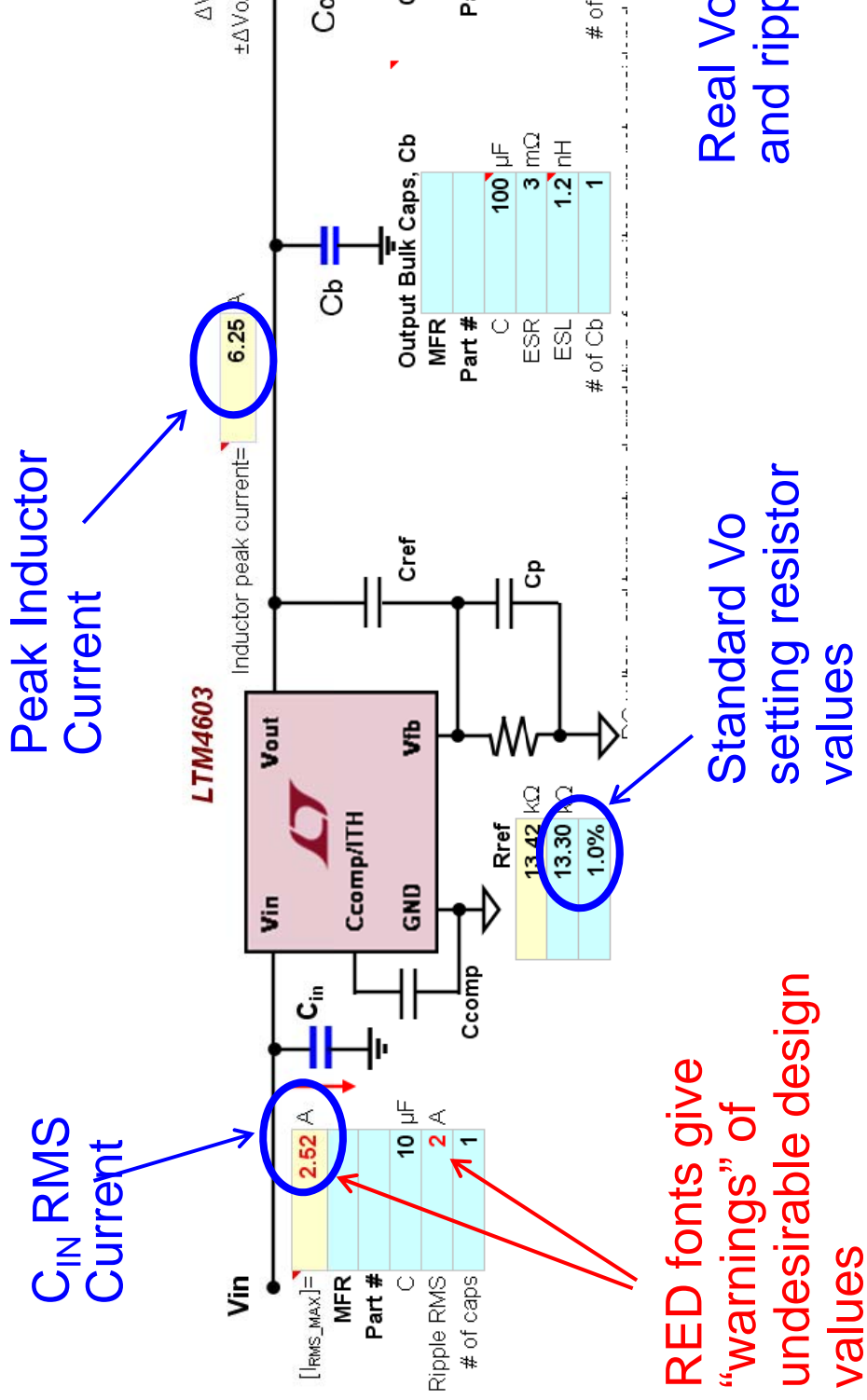

Step 2: Control Loop Optimization

In the design spreadsheet, control loop design can be fine tuned

Sliding bar for compensation

Part II - Small Signal Modeling and Compensation Tuning
 Compensation Component Tuning and Design Verification

Remote sense	<input checked="" type="checkbox"/> Differential Sensing	<input type="checkbox"/> Direct Local Sensing
C _{comp}	47 pF	
V _{comp}	9.79 V	
I _{comp}	5.00 A	
Actual voltage loop bandwidth, [k _{v,actual}]	35.11 kHz	Actual voltage loop phase margin, [φ _{v,actual}]= 80

Voltage Loop Gain
 Magnitude (dB) vs Frequency (kHz). Legend: Magitude (blue solid), Phase (magenta solid), f_c (green dashed), f_{sw/2} (red dashed). A red arrow points to the phase curve.

Output Impedance
 Magnitude (mohm) vs Frequency (kHz). Legend: Magitude (blue solid), Phase (magenta solid). A red oval highlights the phase curve.

Load Transient Approximation (Second Order Approximation; duty cycle and error amplifier saturation is not taken into account valid only with stable system)
 Load Step, [Istep]= 4 A, Absolute Load Step slew rate, [dI/dt]= 1 A/μsec

Load transient prediction
 Average Volt overshoot/under :shoot @ Load Transient vs Time (μsec). Legend: Average Volt overshoot/under :shoot @ Load Transient (blue solid). A red arrow points to the peak of the overshoot curve.

Loop gain prediction

Load transient prediction

Additional Feature (1):

Export to & Run LTspice™ Simula

In the design spreadsheet, click the “Export To LTspice” butto



View Layout Example

Note: Click on a capacitor symbol to link to the library

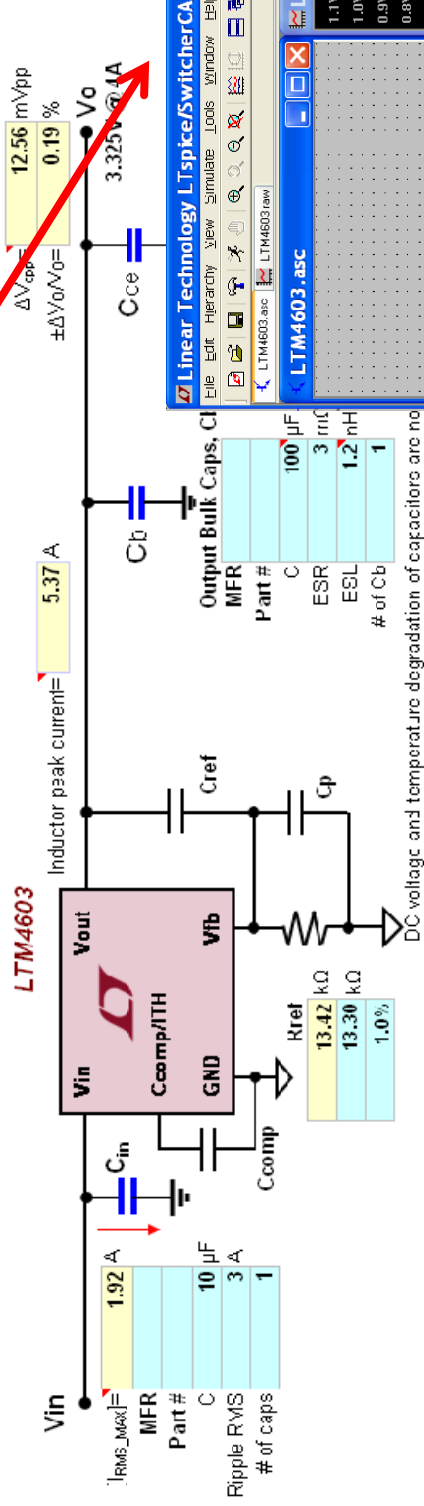

If the LTspice™ simulator is installed, it will be automatically opened:

Link to down load free LTSpice™ simulator:

<http://www.linear.com/designtools/software/ltpspice.jsp>

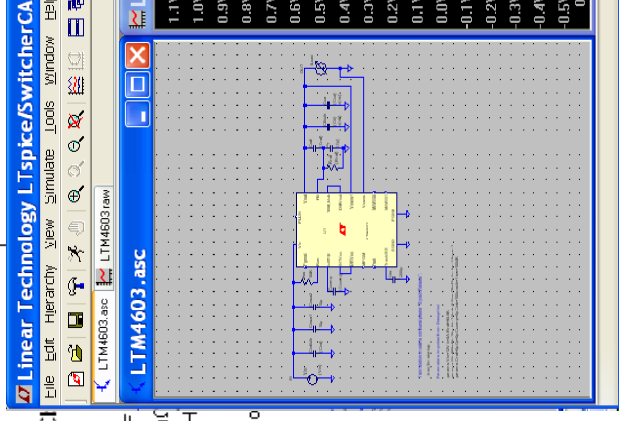

Additional Feature (2):

Summary of design: BOM, size, cost and

In the design spreadsheet, click the “Summary” sheet:

Summary of Design

Bill of Material of Power Components

Component	Part #	# of parts	Value	Unit	⌀ inch	C mm			Unit Price	Total Price
						L	W	H		
Cin (bulk)	0	1	100 μ F	1210	Package	0.098	0.126	N/A		\$0.00
Cin (ceramic)			μ F	1206		0.063	0.126	N/A		\$0.00
Cout (bulk)	2R5TPE2201MC	0	220 μ F	0805		0.049	0.079	N/A		\$0.00
Cout (ceramic)	0.00	1	72 μ F	1210		0.098	0.126	N/A		\$0.00
MicroModule	LTM4603	1		LGA (15 X 15 X2.8)		0.591	0.591	0.110		\$0.00

Power Component Summary:

Foot print clearance factor= 1.5	
Total footprint are W/O output Bulk Capacitors	0.560 inch ²
Total footprint	0.560 inch ²
Total BOM cost W/O input and output Bulk Capacitors	\$0.00
Total BOM cost	\$0.00

Design Analysis

Parameters	Condition	Minimum	Typical	Maximum	Units
Input Voltage		7.000	12.000	14.000	V
Output Voltage		0.984	0.999	1.014	V
Inductor peak-to-peak Ripple			0.909	0.921	A
Frequency			1004.016		KHz
Crossover freq.	Vin=8.09V		119.891		kHz
Phase Margin	Vin=8.09V		39.159		Deg.

It remains the customer's responsibility to verify proper and reliable operation in the actual application.

Any feedback comments on the program or issues encountered are welcome.

Please forward your comments to the addresses below.

LTpowerCAD@Linear.com

LTpowerCAD II v2.0™

Installation

Troubleshooting

I. Microsoft SQL Server Compact 3.5 SP2 ENU requirement :

1) Possible issue: Microsoft SQL Server Compact 3.5 SP2 is requirement missing

LTpowerCAD II v2.0 requires Microsoft SQL Server Compact 3.5 SP2 to access the internal parts database. If this is not installed, the program may have issues accessing information for parts included in the product database. An example screenshot is shown below where this type of error has occurred. *If this is confirmed to be your system, make sure it was installed correctly which may require a repair of the installation or reinstallation of this requirement.*



*** Example shown above is on Windows XP**

Important : Make sure you installed using “setup.exe” file (not the MS.msi file)

Appendix : Installation Troubleshooting

Possible issue solution:

Check the programs you have currently installed on your system to see if Microsoft SQL Server Compact requirement is missing or not. The LTPowerCAD II v2.0 installer automatically checks if you have this requirement will download and install it automatically. This can also be freely downloaded at Microsoft at <http://www.us/download/details.aspx?id=5783> *If this is confirmed to be installed on your system, make sure it was which may require a repair of the installation or new installation of this requirement.*

Step 1) Check the list of programs you have currently installed on your system by going to Start Menu → Control Panel → Programs and Features



Step 2) If this is not installed, this can be downloaded at <http://www.microsoft.com/en-us/download/details.aspx?id=5783> and install this package, then try to un-install / re-install LTPowerCAD II v2.0.

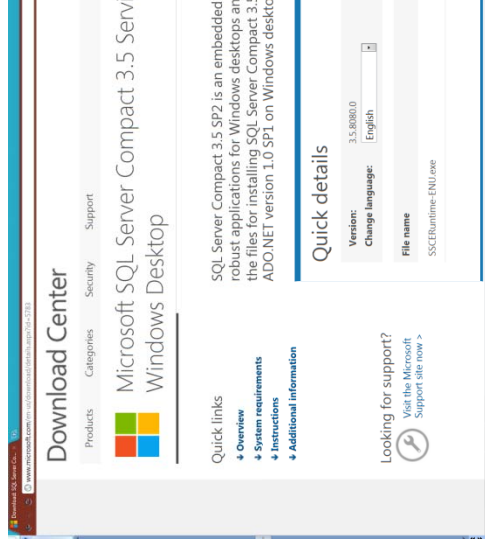

**** Note :** The installer is made download and install these soft to your system if your system have these instal

Important : Make sure you installed using “setup.exe” file (not the MS.msi file)

Appendix : Installation Troubleshooting

II. Microsoft Security Settings :

2) Possible issue: Microsoft Security Settings

Security default settings may prevent access of LTpowerCAD II v2.0 from its database causing an error message to pop up when searching for a part (see below).

The screenshot shows the LTpowerCAD II v2.0 software interface. The main window displays the 'Converter Specification' section with the following settings:

- Converter Topology: All
- Converter Type: All
- Output Rail 1: Vout1 (2.5 V, 5 A)
- Output Rail 2: Vout2 (1 V, 20 A)
- Min. Input Voltage: 12 V
- Nom. Input Voltage: 12 V
- Max. Input Voltage: 12 V
- Num. of Output Rails: Two
- Find Part by Num. (###): [] [Go]

The 'Optional Features' section includes:

- Burst Mode:
- Synchronous FET:
- Sync. to External Clock:

A search error dialog box is overlaid on the interface, displaying the following message:

```
System.Data.EntityException: The underlying provider failed on Open. --->
System.Data.SqlClient.SqlCeException: Access to the database file is not
allowed. [ File name = C:\Program Files (x86)\LTC\LTpowerCAD2\LTDataBase.sdf
]
at System.Data.SqlClient.SqlCeConnection.ProcessResults(Int32 hr)
at System.Data.SqlClient.SqlCeConnection.Open(Boolean silent)
at System.Data.SqlClient.SqlCeConnection.Open()
at System.Data.EntityClient.EntityConnection.OpenStoreConnectionIf(Boolean
openCondition, DbConnection storeConnectionToOpen, DbConnection
originalConnection, String exceptionCode, String attemptedOperation, Boolean&
closeStoreConnectionOnFailure)
--- End of inner exception stack trace ---
at System.Data.EntityClient.EntityConnection.OpenStoreConnectionIf(Boolean
openCondition, DbConnection storeConnectionToOpen, DbConnection
originalConnection, String exceptionCode, String attemptedOperation, Boolean&
closeStoreConnectionOnFailure)
at System.Data.EntityClient.EntityConnection.Open()
at System.Data.Objects.ObjectContext.EnsureConnection()
at System.Data.Objects.ObjectQuery`1.GetResults(Nullable`1 forMergeOption)
at System.Data.Objects.ObjectQuery`1.System.Collections.Generic.ICollection`1.
GetEnumerator()
at System.Collections.Generic.List`1.<ctor>(IEnumerable`1 collection)
at System.Linq.Enumerable.ToList[TSource](IEnumerable`1 source)
at LTpowerCAD.PartSearchWindow.SearchButton_Click(Object sender,
RoutedEventArgs e)
OK
```

**** Note : The installer is made to automatically set up these folder settings. If for some reason you are still getting a similar error please read through the following slides to make sure.**

LTpowerCAD currently supports design tools for a limited number of parts. For more part options click the Web Search button.

Important : Make sure you installed using “setup.exe” file (not the MS.msi file)

LTpowerCAD II v2.0™ Design Tool Quick Start Guide Copyright © 2013 Linear Technology. All rights reserved.

Appendix : Installation Troubleshooting

Possible issue solution:

Run the program with an Administrator account , or try to modify your system's Users account security for now (see below).

Step 1) Go to the LTC folder location: (ie C:\Program Files (x86)\LTC)

Step 2) Right click on the LTPowerCAD 2 program folder → **Properties**

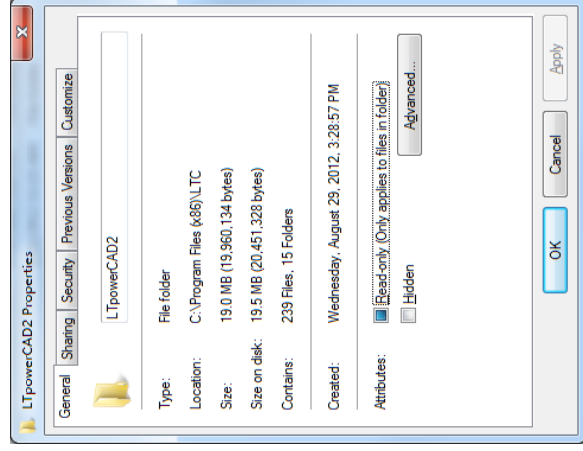

Step 3) Click on the **Security** tab. Click on your **Administrators** that the permissions should show Allow for all options (except permissions). The **SYSTEM** account should also have the same

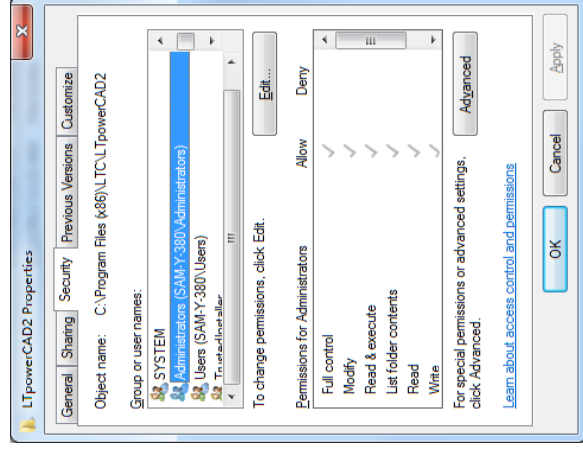

Important : Make sure you installed using “setup.exe” file (not the MS.msi file)

Appendix : Installation Troubleshooting

Possible issue solution (cont'd):

Step 4) Click on your **Users** account to see the user settings. Your user account may not have the permissions set (like shown below) that are needed. You can change these in the next step.

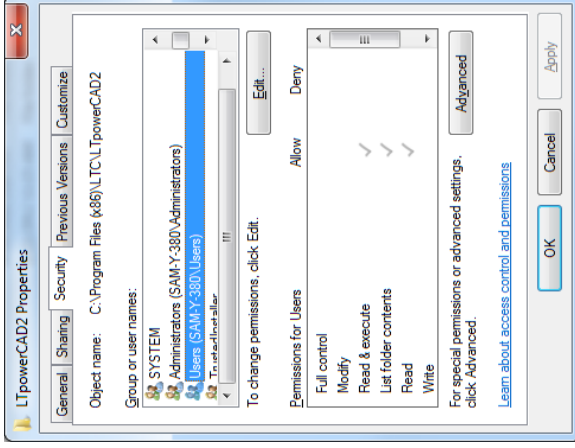

Step5) Click on the **Edit** button and click on your check boxes on the **Allow** column for **Full control**, settings should now be the same as you saw for the

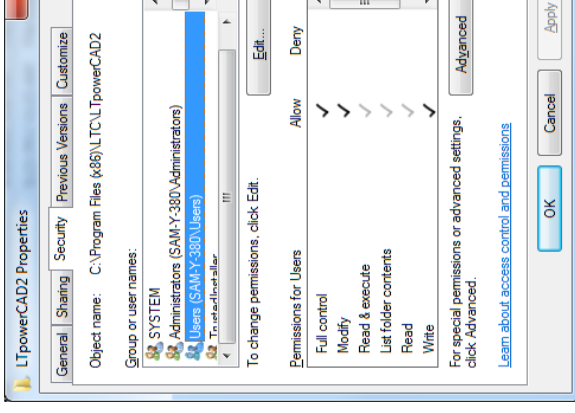

Important : Make sure you installed using “setup.exe” file (not the MS.msi file)

Looking for pricing, stock, or lifecycle information?

Click below to explore more details on WIN SOURCE:

 [View LTM4643IY#PBF on WIN SOURCE](#)

 [Linear Technology](#) Information

Optimize Your Supply Chain with WIN SOURCE Solutions

-  Global Sourcing Solution
-  Obsolete Management
-  Cost Control Management
-  Shortage Management
-  Alternative Solution
-  Excess Inventory Management