



**THE DATASHEET OF
AD8336ACPZ-R7**



General-Purpose, -55°C to $+125^{\circ}\text{C}$, Wide Bandwidth, DC-Coupled VGA

FEATURES

- ▶ Low noise
 - ▶ Voltage noise: $3\text{ nV}/\sqrt{\text{Hz}}$
 - ▶ Current noise: $3\text{ pA}/\sqrt{\text{Hz}}$
- ▶ Small-signal BW: 115 MHz
- ▶ Large-signal BW: $2\text{ V p-p} = 80\text{ MHz}$
- ▶ Slew rate: $550\text{ V}/\mu\text{s}$, 2 V p-p
- ▶ Gain ranges (specified)
 - ▶ -14 dB to $+46\text{ dB}$
 - ▶ 0 dB to 60 dB
- ▶ Gain scaling: 50 dB/V
- ▶ DC-coupled
- ▶ Single-ended input and output
- ▶ Supplies: $\pm 3\text{ V}$ to $\pm 12\text{ V}$
- ▶ Temperature range: -55°C to $+125^{\circ}\text{C}$
- ▶ Power
 - ▶ 150 mW at $\pm 3\text{ V}$, $-55^{\circ}\text{C} < T < +125^{\circ}\text{C}$
 - ▶ 84 mW at $\pm 3\text{ V}$, $\text{PWRA} = 3\text{ V}$

APPLICATIONS

- ▶ Industrial process controls
- ▶ High performance AGC systems
- ▶ I/Q signal processing
- ▶ Video
- ▶ Industrial and medical ultrasound
- ▶ Radar receivers

FUNCTIONAL BLOCK DIAGRAM

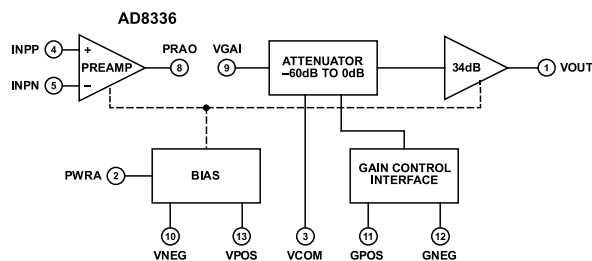

Figure 1.

GENERAL DESCRIPTION

The AD8336 is a low noise, single-ended, linear in dB, general-purpose variable gain amplifier, usable over a large range of supply voltages. It features an uncommitted preamplifier with a usable gain range of 6 dB to 26 dB. The VGA gain range is 0 dB to 60 dB, with absolute gain limits of -26 dB to $+34\text{ dB}$. When the preamplifier gain is adjusted for 12 dB, the combined 3 dB bandwidth of the preamplifier and VGA is 100 MHz, and the amplifier is fully usable to 80 MHz. With $\pm 5\text{ V}$ supplies, the maximum output swing is 7 V p-p .

Because of the X-AMP[®] architecture, frequency response is maintained across the entire gain range of the VGA. The differential gain control interface provides precise linear in dB gain scaling of 50 dB/V over the temperature span of -55°C to $+125^{\circ}\text{C}$ and is simple to interface with a variety of external sources.

The large supply voltage range makes the AD8336 suited for industrial medical applications and video circuits. Dual-supply operation enables bipolar input signals, such as those generated by photodiodes or photomultiplier tubes.

The fully independent voltage feedback preamplifier allows both inverting and noninverting gain topologies. The AD8336 can be used within the specified gain range of -14 dB to $+60\text{ dB}$ by selecting a preamplifier gain between 6 dB and 26 dB and choosing appropriate feedback resistors. For the nominal preamplifier gain of $4\times$, the overall gain range is -14 dB to $+46\text{ dB}$.

If required, quiescent power is limited to a safe level by asserting the PWRA pin.

TABLE OF CONTENTS

Features.....	1	Setting the Gain.....	21
Applications.....	1	Noise.....	21
General Description.....	1	Offset Voltage.....	21
Functional Block Diagram.....	1	Applications Information.....	22
Specifications.....	3	Amplifier Configuration.....	22
Absolute Maximum Ratings.....	6	Preamplifier.....	22
ESD Caution.....	6	Using the Power Adjust Feature.....	23
Pin Configuration and Function Descriptions.....	7	Driving Capacitive Loads.....	23
Typical Performance Characteristics.....	8	Evaluation Board.....	24
Test Circuits.....	17	Optional Circuitry.....	24
Theory of Operation.....	20	Board Layout Considerations.....	24
Overview.....	20	Outline Dimensions.....	26
Preamplifier.....	20	Ordering Guide.....	26
VGA.....	20	Evaluation Boards.....	26

REVISION HISTORY**4/2022—Rev. F to Rev. G**

Change to Quiescent Current $V_S = \pm 12$ V Parameter, Table 1.....	3
--	---

SPECIFICATIONS

$V_S = \pm 5\text{ V}$, $T = 25^\circ\text{C}$, gain range = -14 dB to $+46\text{ dB}$, preamplifier gain = $4\times$, $f = 1\text{ MHz}$, $C_L = 5\text{ pF}$, $R_L = 500\ \Omega$, PWRA = GND, unless otherwise specified.

Table 1.

Parameter	Test Conditions/Comments	Min	Typ	Max	Unit ¹				
PREAMPLIFIER									
-3 dB Small-Signal Bandwidth	$V_{OUT} = 10\text{ mV p-p}$		150		MHz				
-3 dB Large-Signal Bandwidth	$V_{OUT} = 2\text{ V p-p}$		85		MHz				
Bias Current, Either Input			725		nA				
Differential Offset Voltage			± 600		μV				
Input Resistance			900		k Ω				
Input Capacitance			3		pF				
PREAMPLIFIER + VGA									
-3 dB Small-Signal Bandwidth	$V_{OUT} = 10\text{ mV p-p}$		115		MHz				
	$V_{OUT} = 10\text{ mV p-p}$, PWRA = 5 V		40		MHz				
	$V_{OUT} = 10\text{ mV p-p}$, preamplifier gain = $20\times$		20		MHz				
	$V_{OUT} = 10\text{ mV p-p}$, preamplifier gain = $-3\times$		125		MHz				
-3 dB Large-Signal Bandwidth	$V_{OUT} = 2\text{ V p-p}$		80		MHz				
	$V_{OUT} = 2\text{ V p-p}$, PWRA = 5 V		30		MHz				
	$V_{OUT} = 2\text{ V p-p}$, preamplifier gain = $20\times$		20		MHz				
	$V_{OUT} = 2\text{ V p-p}$, preamplifier gain = $-3\times$		100		MHz				
Slew Rate	$V_{OUT} = 2\text{ V p-p}$		550		V/ μs				
Short-Circuit Preamplifier Input Voltage Noise Spectral Density	$\pm 3\text{ V} \leq V_S \leq \pm 12\text{ V}$		3.0		nV/ $\sqrt{\text{Hz}}$				
Input Current Noise Spectral Density			3.0		pA/ $\sqrt{\text{Hz}}$				
Output-Referred Noise	$V_{GAIN} = 0.7\text{ V}$, preamplifier gain = $4\times$		600		nV/ $\sqrt{\text{Hz}}$				
	$V_{GAIN} = -0.7\text{ V}$, preamplifier gain = $4\times$		190		nV/ $\sqrt{\text{Hz}}$				
	$V_{GAIN} = 0.7\text{ V}$, preamplifier gain = $20\times$		2500		nV/ $\sqrt{\text{Hz}}$				
	$V_{GAIN} = -0.7\text{ V}$, preamplifier gain = $20\times$		200		nV/ $\sqrt{\text{Hz}}$				
	$V_{GAIN} = 0.7\text{ V}$, $-55^\circ\text{C} \leq T \leq +125^\circ\text{C}$		700		nV/ $\sqrt{\text{Hz}}$				
	$V_{GAIN} = -0.7\text{ V}$, $-55^\circ\text{C} \leq T \leq +125^\circ\text{C}$		250		nV/ $\sqrt{\text{Hz}}$				
DYNAMIC PERFORMANCE									
Harmonic Distortion	$V_{GAIN} = 0\text{ V}$, $V_{OUT} = 1\text{ V p-p}$	$f = 1\text{ MHz}$	-58		dBc				
						HD2			
HD3		$f = 1\text{ MHz}$	-68		dBc				
HD2		$f = 10\text{ MHz}$	-60		dBc				
						HD3			
HD3		$f = 10\text{ MHz}$	-60		dBc				
Input 1 dB Compression Point	$V_{GAIN} = -0.7\text{ V}$		11		dBm				
						$V_{GAIN} = +0.7\text{ V}$	-23		dBm
Two-Tone Intermodulation Distortion (IMD3)	$V_{GAIN} = 0\text{ V}$, $V_{OUT} = 1\text{ V p-p}$, $f_1 = 0.95\text{ MHz}$, $f_2 = 1.05\text{ MHz}$		-71		dBc				
						$V_{GAIN} = 0\text{ V}$, $V_{OUT} = 1\text{ V p-p}$, $f_1 = 9.95\text{ MHz}$, $f_2 = 10.05\text{ MHz}$	-69		dBc
Output Third-Order Intercept	$V_{GAIN} = 0\text{ V}$, $V_{OUT} = 2\text{ V p-p}$, $f_1 = 0.95\text{ MHz}$, $f_2 = 1.05\text{ MHz}$		-60		dBc				
						$V_{GAIN} = 0\text{ V}$, $V_{OUT} = 2\text{ V p-p}$, $f_1 = 9.95\text{ MHz}$, $f_2 = 10.05\text{ MHz}$	-58		dBc
						$V_{GAIN} = 0\text{ V}$, $V_{OUT} = 1\text{ V p-p}$, $f = 1\text{ MHz}$	34		dBm
						$V_{GAIN} = 0\text{ V}$, $V_{OUT} = 1\text{ V p-p}$, $f = 10\text{ MHz}$	32		dBm
Overdrive Recovery	$V_{GAIN} = 0\text{ V}$, $V_{OUT} = 2\text{ V p-p}$, $f = 1\text{ MHz}$		34		dBm				
						$V_{GAIN} = 0\text{ V}$, $V_{OUT} = 2\text{ V p-p}$, $f = 10\text{ MHz}$	33		dBm
						$V_{GAIN} = 0.7\text{ V}$, $V_{IN} = 100\text{ mV p-p}$ to 5 mV p-p	50		ns
Group Delay Variation	1 MHz < f < 10 MHz, full gain range		± 1		ns				
						1 MHz < f < 10 MHz, full gain range	± 3		ns
ABSOLUTE GAIN ERROR ²	$-0.7\text{ V} < V_{GAIN} < -0.6\text{ V}$	0	1 to 5	6	dB				

SPECIFICATIONS

Table 1.

Parameter	Test Conditions/Comments	Min	Typ	Max	Unit ¹
	$-0.6\text{ V} < V_{\text{GAIN}} < -0.5\text{ V}$	0	0.5 to 1.5	3	dB
	$-0.5\text{ V} < V_{\text{GAIN}} < +0.5\text{ V}$	-1.25	± 0.2	+1.25	dB
	$-0.5\text{ V} < V_{\text{GAIN}} < +0.5\text{ V}$, $\pm 3\text{ V} \leq V_{\text{S}} \leq \pm 12\text{ V}$		± 0.5	+1.25	dB
	$-0.5\text{ V} < V_{\text{GAIN}} < +0.5\text{ V}$, $-55^{\circ}\text{C} \leq T \leq +125^{\circ}\text{C}$		± 0.5		dB
	$-0.5\text{ V} < V_{\text{GAIN}} < +0.5\text{ V}$, preamplifier gain = $-3\times$		± 0.5		dB
	$0.5\text{ V} < V_{\text{GAIN}} < +0.6\text{ V}$	-4.0	-1.5 to -3.0	0	dB
	$0.6\text{ V} < V_{\text{GAIN}} < +0.7\text{ V}$	-9.0	-1 to -5	0	dB
GAIN CONTROL INTERFACE					
Gain Scaling Factor		48	49.9	52	dB/V
Intercept	Preamplifier + VGA		16.4		dB
	VGA only		4.5		dB
Gain Range		58	60	62	dB
Input Voltage (V_{GAIN}) Range	No foldover	$-V_{\text{S}}$		$+V_{\text{S}}$	V
Input Current			1		μA
Response Time	60 dB gain change		300		ns
OUTPUT PERFORMANCE					
Output Impedance, DC to 10 MHz	$\pm 3\text{ V} \leq V_{\text{S}} \leq \pm 12\text{ V}$		2.5		Ω
Output Signal Swing	$R_{\text{L}} \geq 500\ \Omega$ (for $ V_{\text{S}} \leq \pm 5\text{ V}$); $R_{\text{L}} \geq 1\ \text{k}\Omega$ above that		$ V_{\text{S}} - 1.5$		V
	$R_{\text{L}} \geq 1\ \text{k}\Omega$ (for $ V_{\text{S}} = \pm 12\text{ V}$)		$ V_{\text{S}} - 2.25$		V
Output Current	Linear operation - minimum discernable distortion		20		mA
Short-Circuit Current	$V_{\text{S}} = \pm 3\text{ V}$		+123/-72		mA
	$V_{\text{S}} = \pm 5\text{ V}$		+123/-72		mA
	$V_{\text{S}} = \pm 12\text{ V}$		+72/-73		mA
Output Offset Voltage	$V_{\text{GAIN}} = 0.7\text{ V}$, gain = $200\times$	-250	-125	+150	mV
	$\pm 3\text{ V} \leq V_{\text{S}} \leq \pm 12\text{ V}$		-200		mV
	$-55^{\circ}\text{C} \leq T \leq +125^{\circ}\text{C}$		-200		mV
PWRA PIN					
Normal Power (Logic Low)	$V_{\text{S}} = \pm 3\text{ V}$			0.7	V
Low Power (Logic High)	$V_{\text{S}} = \pm 3\text{ V}$	1.5			V
Normal Power (Logic Low)	$V_{\text{S}} = \pm 5\text{ V}$			1.2	V
Low Power (Logic High)	$V_{\text{S}} = \pm 5\text{ V}$	2.0			V
Normal Power (Logic Low)	$V_{\text{S}} = \pm 12\text{ V}$			3.2	V
Low Power (Logic High)	$V_{\text{S}} = \pm 12\text{ V}$	4.0			V
POWER SUPPLY					
Supply Voltage Operating Range		± 3		± 12	V
Quiescent Current					
$V_{\text{S}} = \pm 3\text{ V}$		22	25	30	mA
	$-55^{\circ}\text{C} \leq T \leq +125^{\circ}\text{C}$		23 to 31		mA
	PWRA = 3 V	10	14	18	mA
$V_{\text{S}} = \pm 5\text{ V}$		22	26	30	mA
	$-55^{\circ}\text{C} \leq T \leq +125^{\circ}\text{C}$		23 to 31		mA
	PWRA = 5 V	10	14	18	mA
$V_{\text{S}} = \pm 12\text{ V}$		23	28	33	mA
	$-55^{\circ}\text{C} \leq T \leq +125^{\circ}\text{C}$		24 to 35		mA
	PWRA = 5 V		16		mA
Power Dissipation	$V_{\text{S}} = \pm 3\text{ V}$		150		mW
	$V_{\text{S}} = \pm 5\text{ V}$		260		mW
	$V_{\text{S}} = \pm 12\text{ V}$		672		mW

SPECIFICATIONS**Table 1.**

Parameter	Test Conditions/Comments	Min	Typ	Max	Unit ¹
Power Supply Rejection Ratio (PSRR)	$V_{\text{GAIN}} = 0.7 \text{ V}$, $f = 1 \text{ MHz}$		-40		dB

¹ All dBm values are calculated with 50 Ω reference, unless otherwise noted.

² Conformance to theoretical gain expression (see the [Setting the Gain](#) section).

ABSOLUTE MAXIMUM RATINGS

Table 2.

Parameter	Rating
Supply Voltage (VPOS, VNEG)	±15 V
Input Voltage (INPP, INPN)	VPOS, VNEG
Gain Voltage (GPOS, GNEG)	VPOS, VNEG
PWRA	5 V, GND
VGAI	VPOS + 0.6 V, VNEG - 0.6 V
Power Dissipation	
$V_S \leq \pm 5$ V	0.43 W
± 5 V < $V_S \leq \pm 12$ V	1.12 W
Operating Temperature Range	
± 3 V < $V_S \leq \pm 10$ V	-55°C to +125°C
± 10 V < $V_S \leq \pm 12$ V	-55°C to +85°C
Storage Temperature Range	-65°C to +150°C
Lead Temperature (Soldering 60 sec)	300°C
Thermal Data ¹	
θ_{JA}	58.2°C/W
θ_{JB}	35.9°C/W
θ_{JC}	9.2°C/W
Ψ_{JT}	1.1°C/W
Ψ_{JB}	34.5°C/W

¹ 4-layer JEDEC board, no airflow, exposed pad soldered to printed circuit board.

Stresses at or above those listed under Absolute Maximum Ratings may cause permanent damage to the product. This is a stress rating only; functional operation of the product at these or any other conditions above those indicated in the operational section of this specification is not implied. Operation beyond the maximum operating conditions for extended periods may affect product reliability.

ESD CAUTION



ESD (electrostatic discharge) sensitive device. Charged devices and circuit boards can discharge without detection. Although this product features patented or proprietary protection circuitry, damage may occur on devices subjected to high energy ESD. Therefore, proper ESD precautions should be taken to avoid performance degradation or loss of functionality.

PIN CONFIGURATION AND FUNCTION DESCRIPTIONS

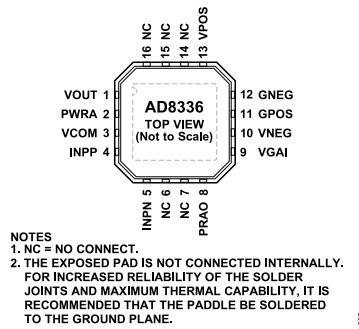

Figure 2. Pin Configuration

Table 3. Pin Function Descriptions

Pin No.	Mnemonic	Description
1	VOUT	Output Voltage.
2	PWRA	Power Control. Normal power when grounded; power reduced by half if PWRA is pulled high.
3	VCOM	Common-Mode Voltage. Normally GND when using a dual supply.
4	INPP	Positive Input to Preamplifier.
5	INPN	Negative Input to Preamplifier.
6	NC	No Connect.
7	NC	No Connect.
8	PRAO	Preamplifier Output.
9	VGAI	VGA Input.
10	VNEG	Negative Supply.
11	GPOS	Positive Gain Control Input.
12	GNEG	Negative Gain Control Input.
13	VPOS	Positive Supply.
14	NC	No Connect.
15	NC	No Connect.
16	NC	No Connect.
Not applicable	EPAD	The Exposed Pad is Not Connected Internally. For increased reliability of the solder joints and maximum thermal capability, it is recommended that the paddle be soldered to the ground plane.

TYPICAL PERFORMANCE CHARACTERISTICS

$V_S = \pm 5\text{ V}$, $T = 25^\circ\text{C}$, gain range = -14 dB to $+46\text{ dB}$, preamplifier gain = $4\times$, $f = 1\text{ MHz}$, $C_L = 5\text{ pF}$, $R_L = 500\ \Omega$, PWRA = GND, unless otherwise specified.

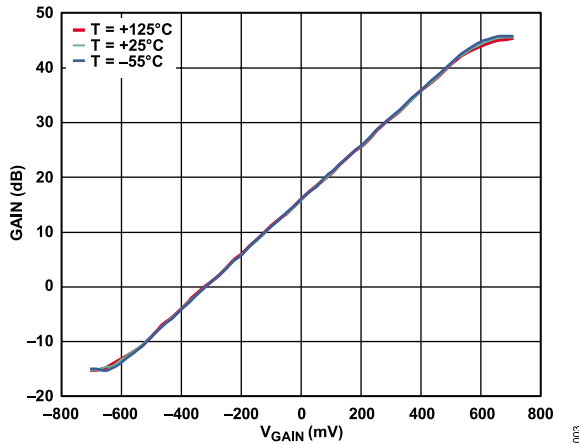

Figure 3. Gain vs. V_{GAIN} for Three Values of Temperature (T), (See Figure 56)

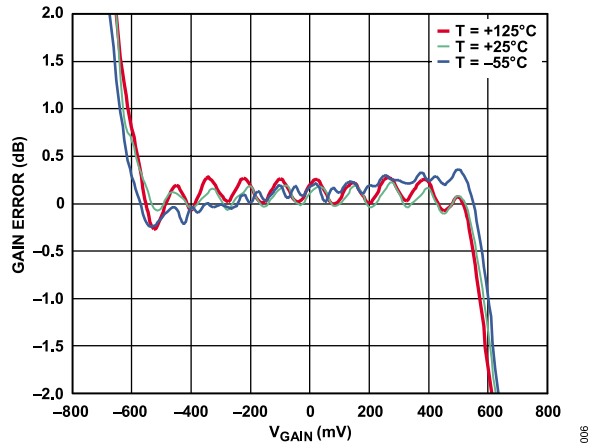

Figure 6. Gain Error vs. V_{GAIN} for Three Values of Temperature (T), (See Figure 56)

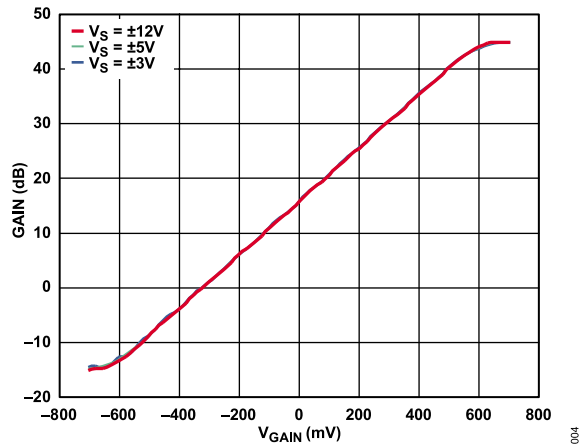

Figure 4. Gain vs. V_{GAIN} for Three Values of Supply Voltage (V_S), (See Figure 56)

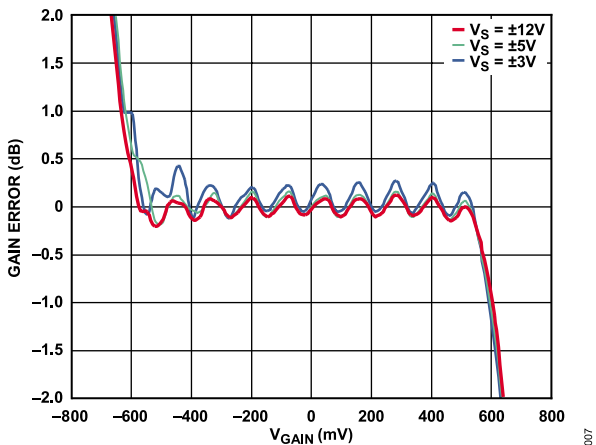

Figure 7. Gain Error vs. V_{GAIN} for Three Values of Supply Voltage (V_S), (See Figure 56)

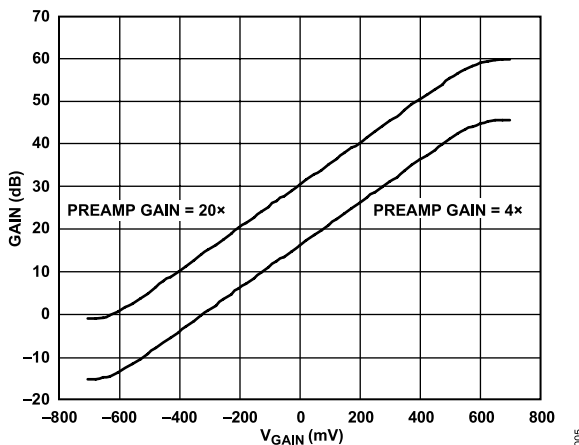

Figure 5. Gain vs. V_{GAIN} for Preamplifier Gains of $4\times$ and $20\times$ (See Figure 56)

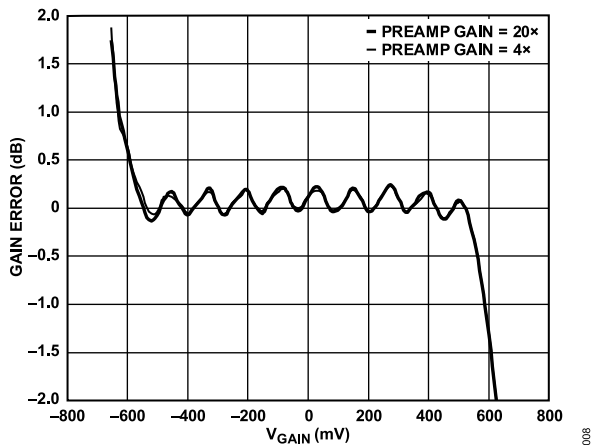

Figure 8. Gain Error vs. V_{GAIN} for Preamplifier Gains of $4\times$ and $20\times$ (See Figure 56)

TYPICAL PERFORMANCE CHARACTERISTICS

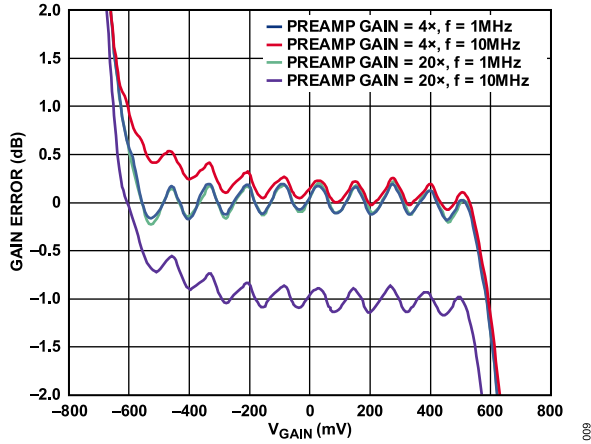

Figure 9. Gain Error vs. V_{GAIN} at 1 MHz and 10 MHz and for Pre-amplifier Gains of 4x and 20x (See Figure 56)

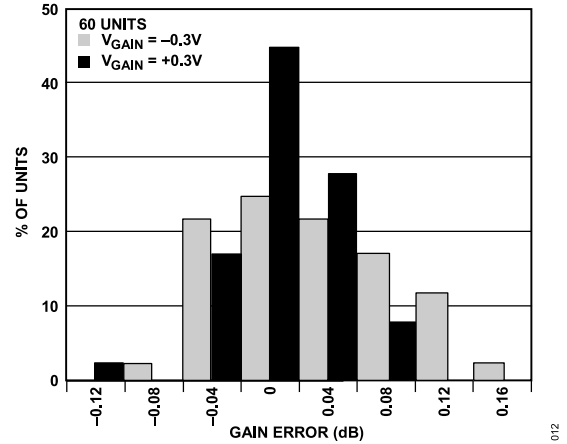

Figure 12. Gain Error Histogram

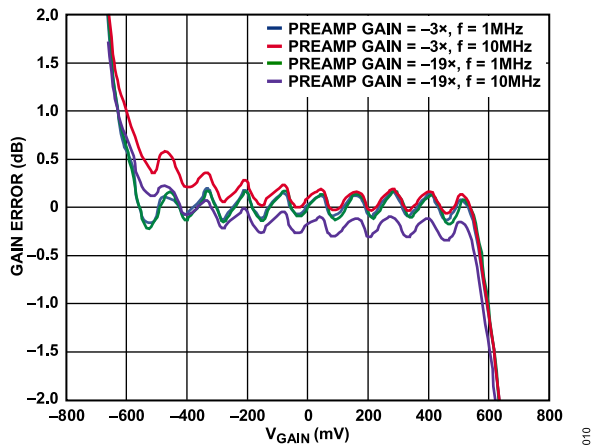

Figure 10. Gain Error vs. V_{GAIN} at 1 MHz and 10 MHz and for Inverting Pre-amplifier Gains of -3x and -19x (See Figure 56)

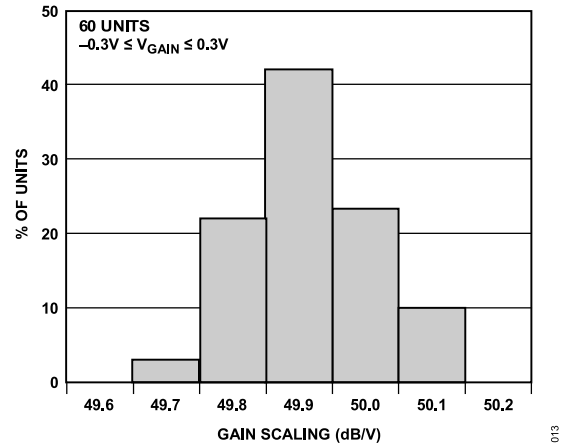

Figure 13. Gain Scaling Factor Histogram

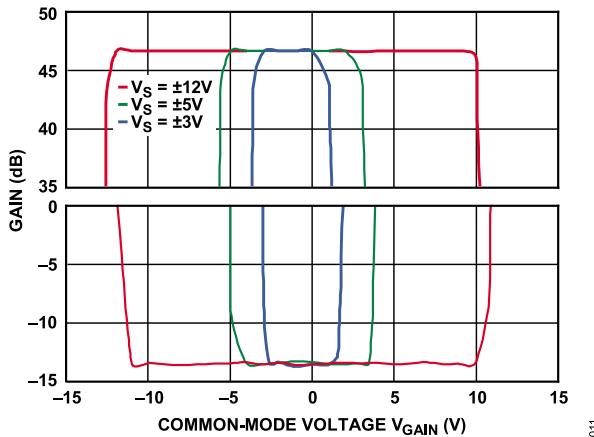

Figure 11. Gain vs. Common-Mode Voltage at V_{GAIN}

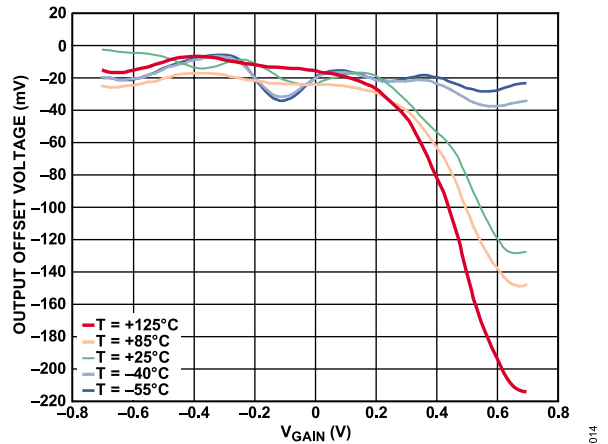

Figure 14. Output Offset Voltage vs. V_{GAIN} for Various Values of Temperature (T)

TYPICAL PERFORMANCE CHARACTERISTICS

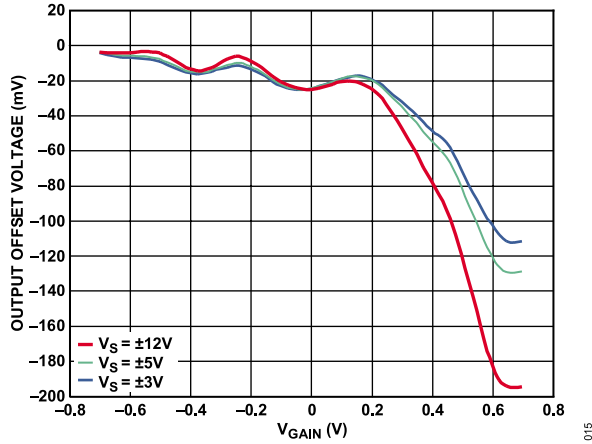

Figure 15. Output Offset Voltage vs. V_{GAIN} for Three Values of Supply Voltage (V_S)

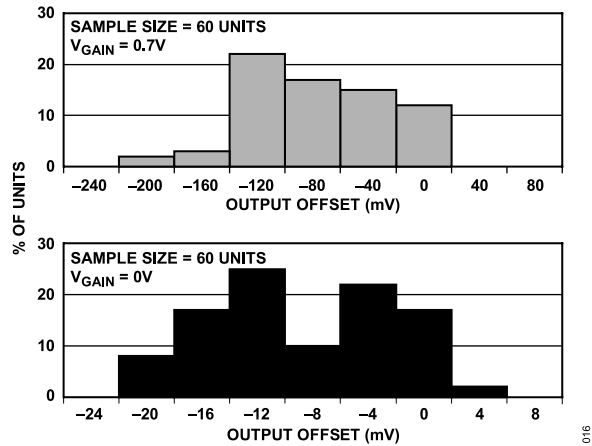

Figure 16. Output Offset Histogram

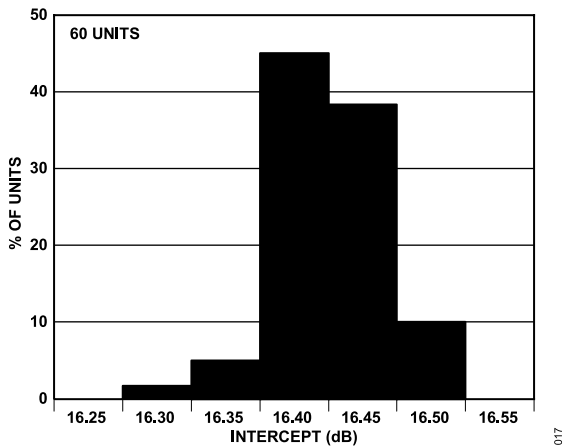

Figure 17. Intercept Histogram

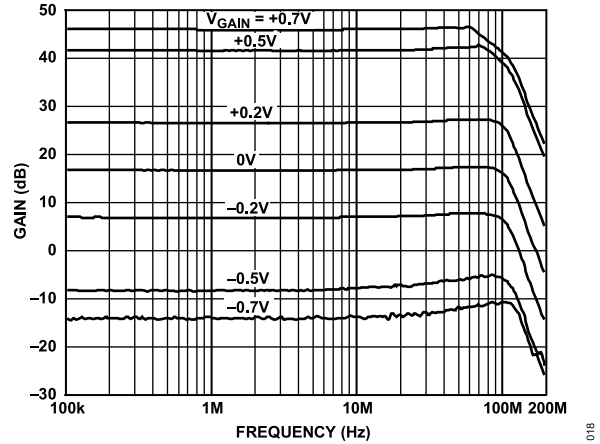

Figure 18. Frequency Response for Various Values of V_{GAIN} (See Figure 57)

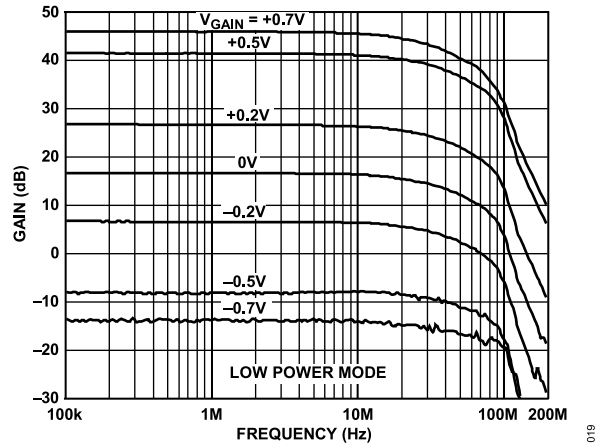

Figure 19. Frequency Response for Various Values of V_{GAIN} , Low Power Mode (See Figure 57)

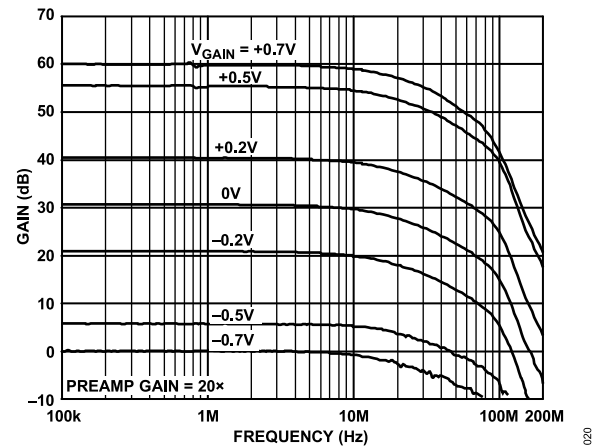

Figure 20. Frequency Response for Various Values of V_{GAIN} When the Preamp Gain is $20\times$ (See Figure 57)

TYPICAL PERFORMANCE CHARACTERISTICS

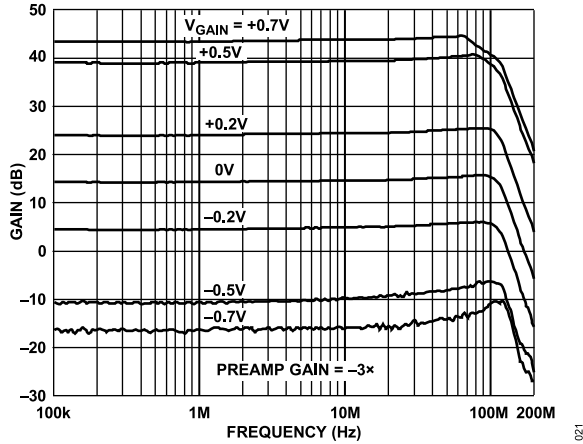

Figure 21. Frequency Response for Various Values of V_{GAIN} When the Preamplifier Gain is $-3\times$ (See Figure 69 and Figure 57)

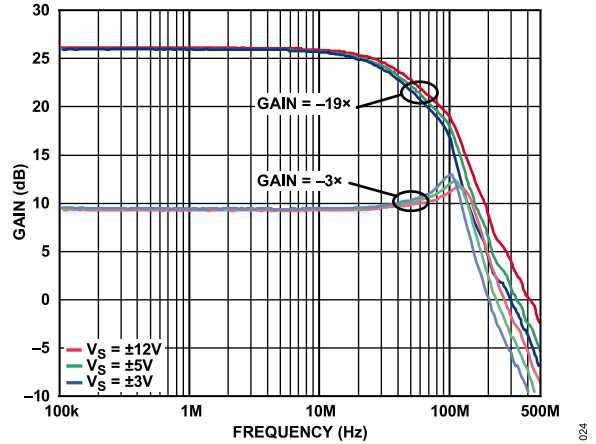

Figure 24. Preamplifier Frequency Response for Three Values of Supply Voltage (V_S) When the Inverting Gain Value is $-3\times$ or $-19\times$ (See Figure 69)

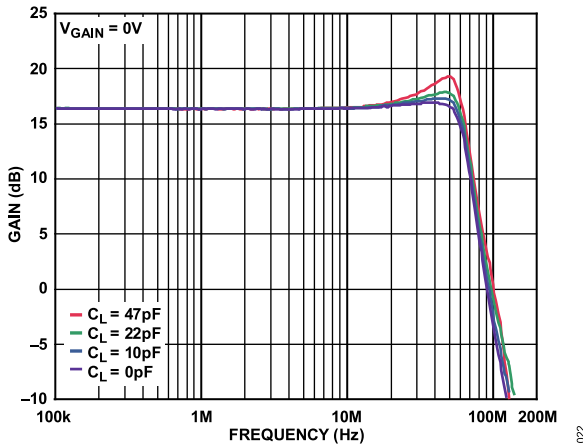

Figure 22. Frequency Response for Various Values of Load Capacitance (C_L), (See Figure 57)

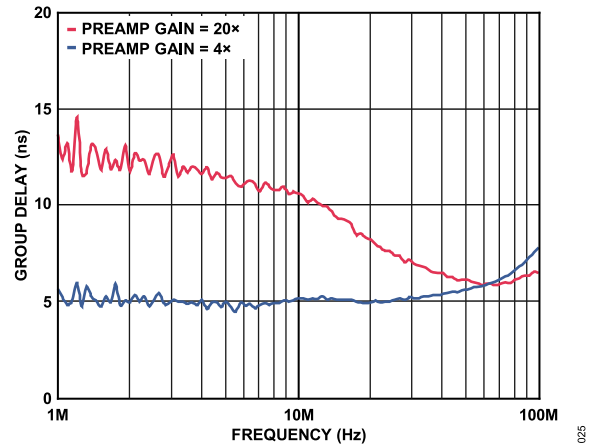

Figure 25. Group Delay vs. Frequency for Preamplifier Gains of $4\times$ and $20\times$ (See Figure 59)

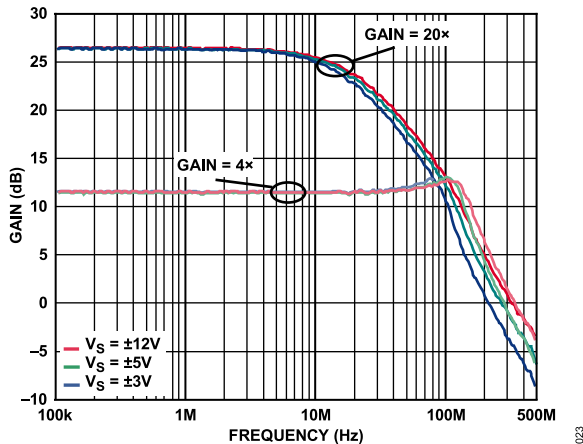

Figure 23. Preamplifier Frequency Response for Three Values of Supply Voltage (V_S) When the Preamplifier Gain is $4\times$ or $20\times$ (See Figure 58)

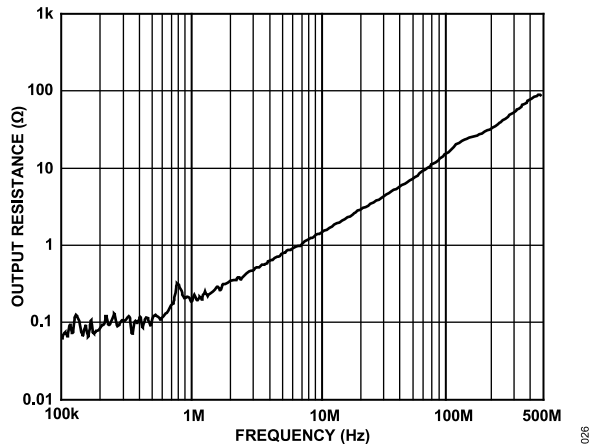

Figure 26. Output Resistance vs. Frequency of the Preamplifier (See Figure 61)

TYPICAL PERFORMANCE CHARACTERISTICS

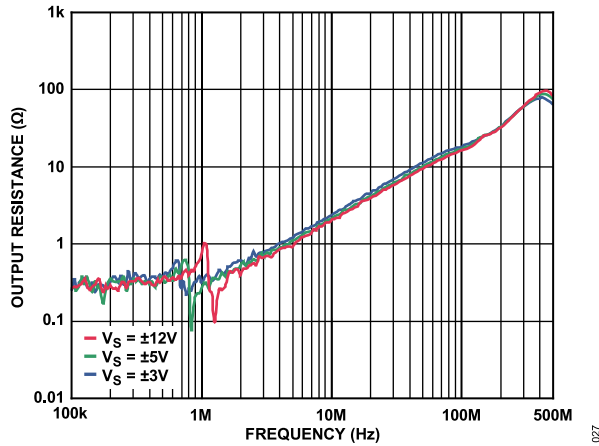

Figure 27. Output Resistance vs. Frequency of the VGA for Three Values of Supply Voltage (V_S), (See Figure 61)

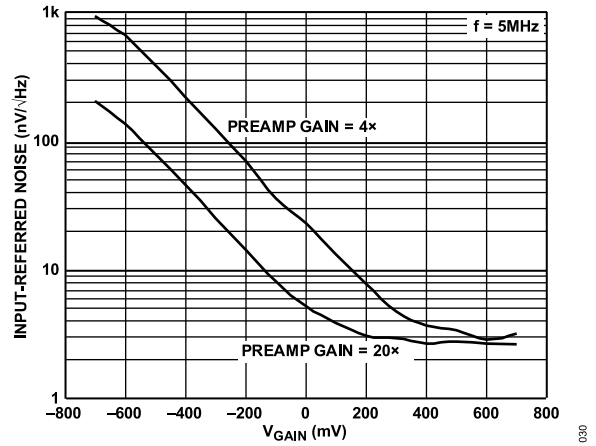

Figure 30. Input-Referred Noise vs. V_{GAIN} for Preamplifier Gains of 4× and 20× (See Figure 62)

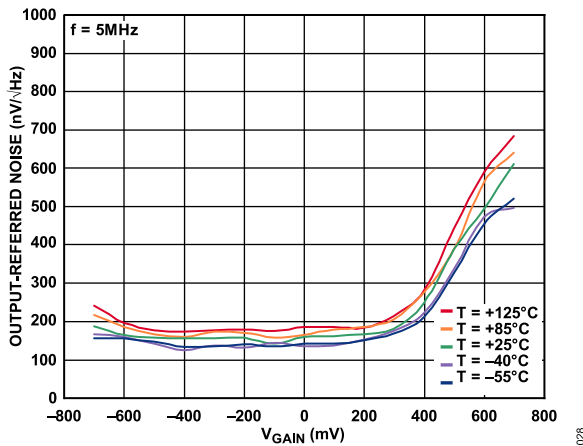

Figure 28. Output-Referred Noise vs. V_{GAIN} at Various Temperatures (T), (See Figure 62)

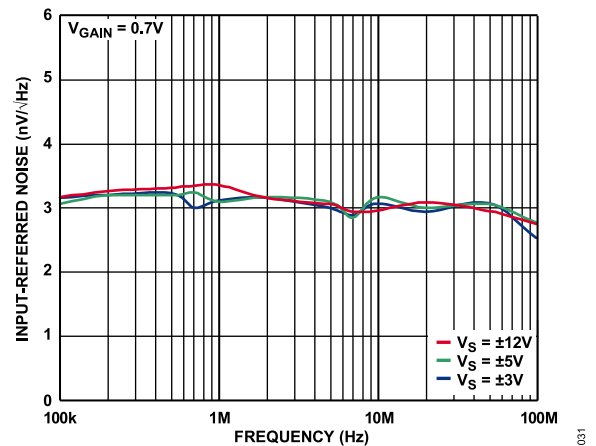

Figure 31. Short-Circuit Input-Referred Noise vs. Frequency at Maximum Gain for Three Values of Supply Voltage (V_S), (See Figure 62)

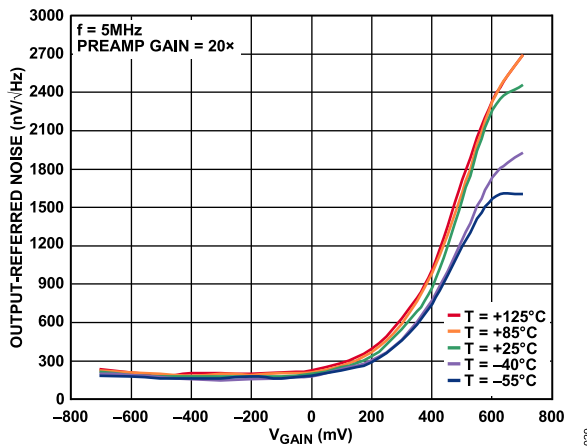

Figure 29. Output-Referred Noise vs. V_{GAIN} at Various Temperatures (T) When the Preamplifier Gain is 20× (See Figure 62)

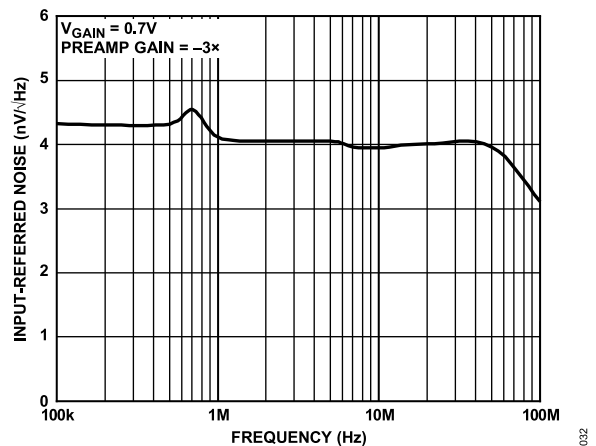

Figure 32. Short-Circuit Input-Referred Noise vs. Frequency at Maximum Inverting Gain (See Figure 73)

TYPICAL PERFORMANCE CHARACTERISTICS

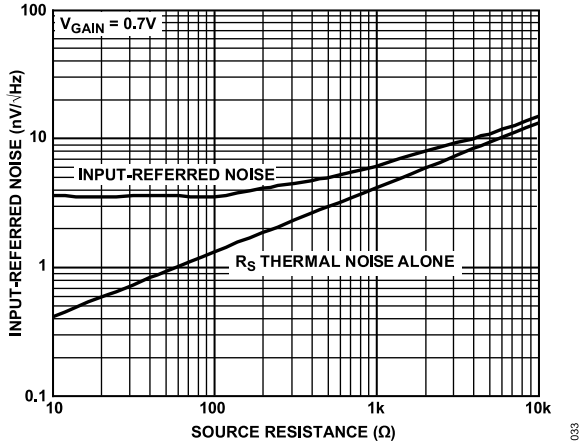

Figure 33. Input-Referred Noise vs. Source Resistance (See Figure 72)

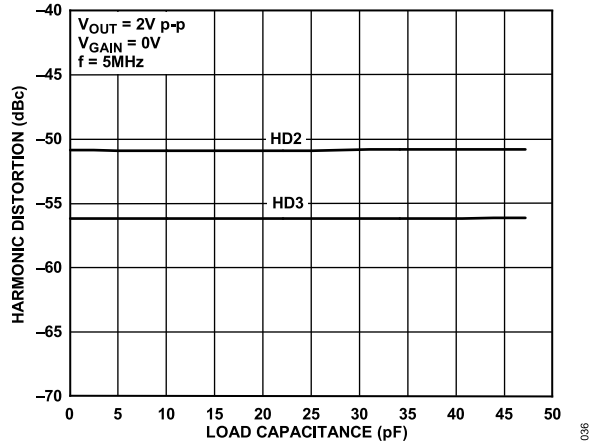

Figure 36. Harmonic Distortion vs. Load Capacitance (See Figure 64)

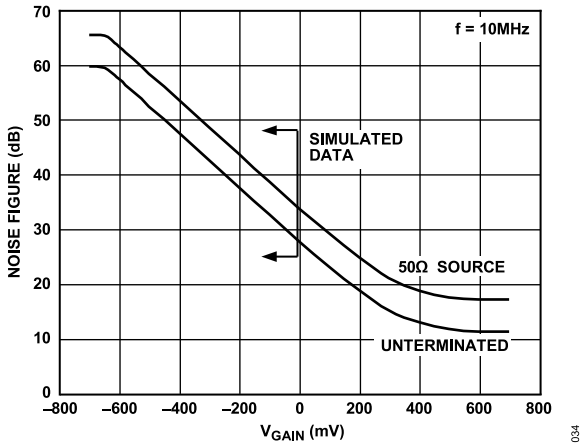

Figure 34. Noise Figure vs. V_{GAIN} (See Figure 63)

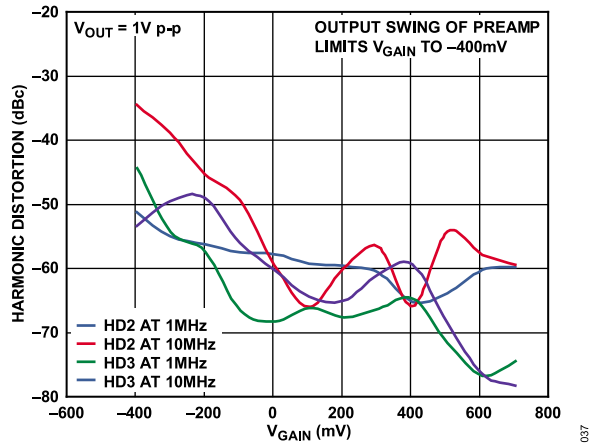

Figure 37. Second and Third Harmonic Distortion vs. V_{GAIN} at 1 MHz and 10 MHz (See Figure 64)

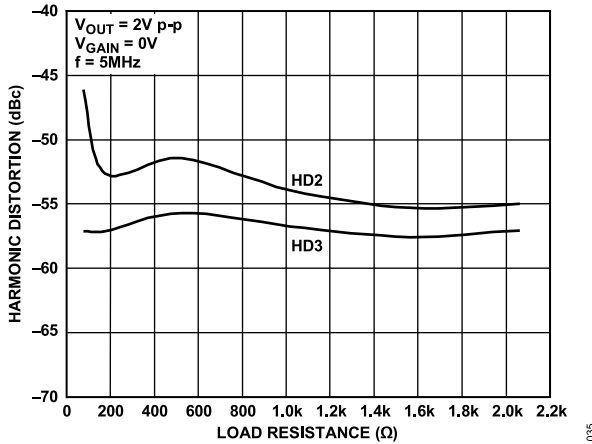

Figure 35. Harmonic Distortion vs. Load Resistance (See Figure 64)

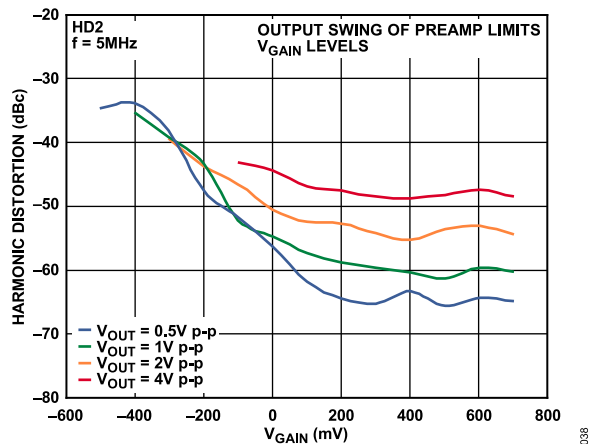

Figure 38. Second Harmonic Distortion vs. V_{GAIN} for Four Values of Output Voltage (V_{OUT}), (See Figure 64)

TYPICAL PERFORMANCE CHARACTERISTICS

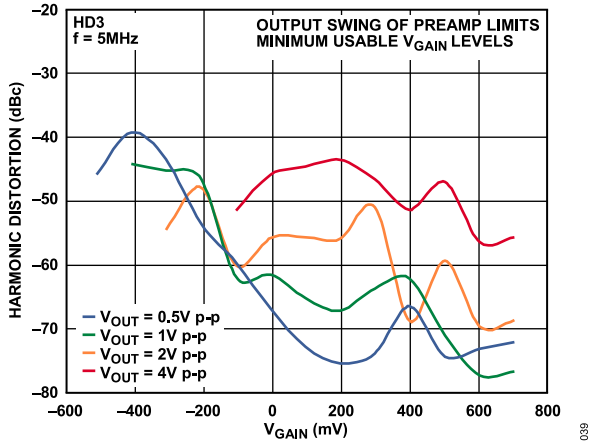

Figure 39. Third Harmonic Distortion vs. V_GAIN for Four Values of Output Voltage (V_OUT), (See Figure 64)

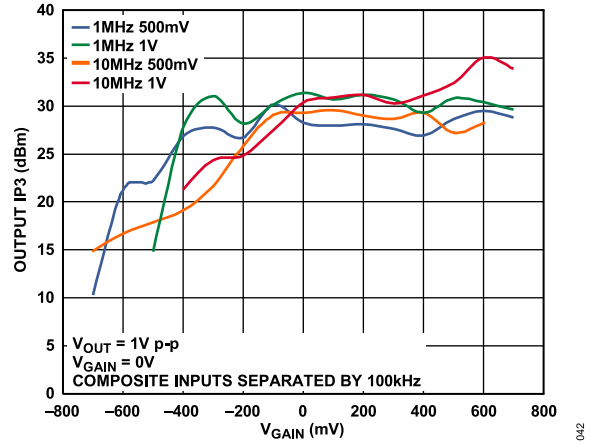

Figure 42. Output-Referred IP3 (OIP3) vs. V_GAIN at Two Frequencies and Two Input Levels (See Figure 76)

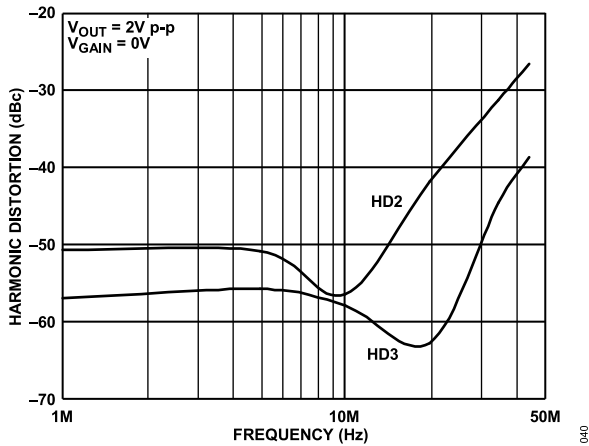

Figure 40. Harmonic Distortion vs. Frequency (See Figure 64)

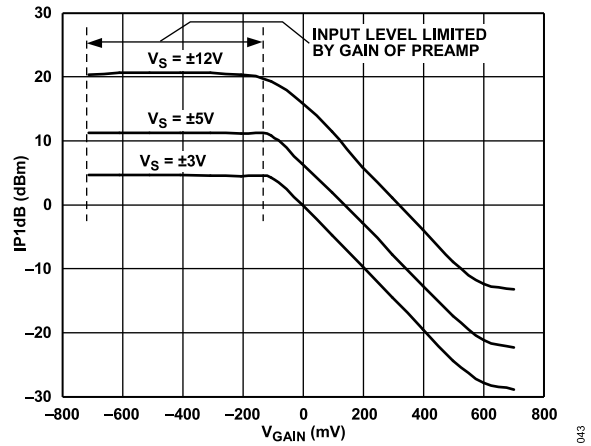

Figure 43. Input P1dB (IP1dB) vs. V_GAIN at Three Power Supply Values (V_S), (See Figure 74 and Figure 75)

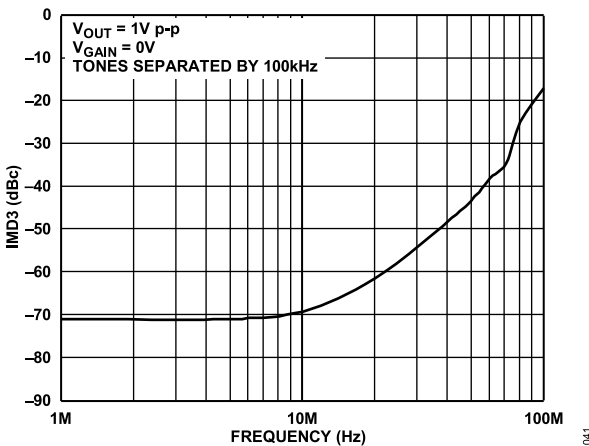

Figure 41. IMD3 vs. Frequency (See Figure 76)

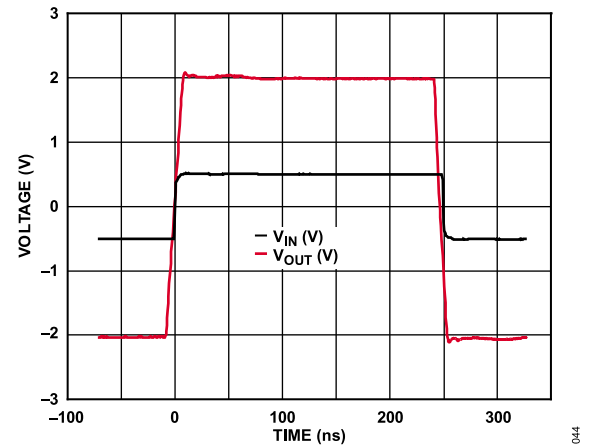

Figure 44. Large-Signal Pulse Response of the Preamp (See Figure 65)

TYPICAL PERFORMANCE CHARACTERISTICS

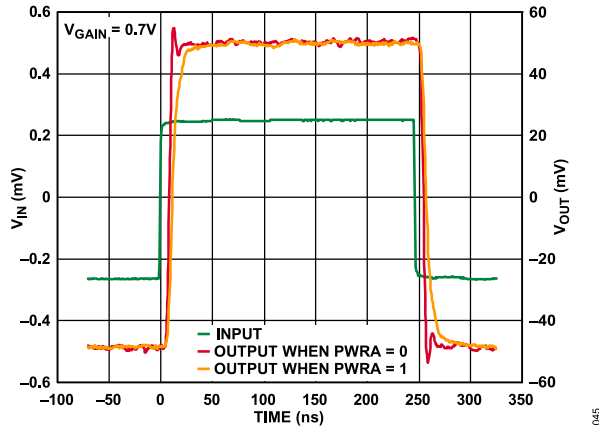

Figure 45. Noninverting Small-Signal Pulse Response for Both Power Levels (See Figure 65)

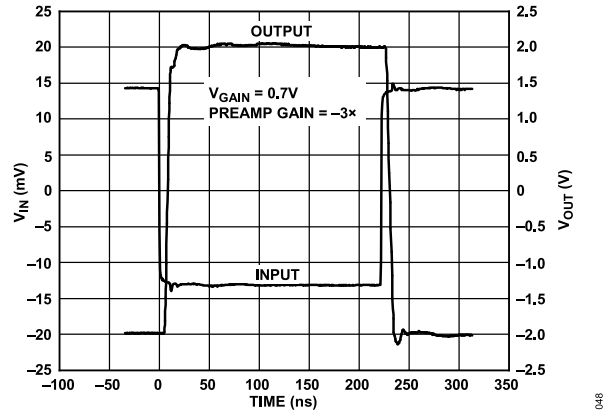

Figure 48. Inverting Gain Large-Signal Pulse Response (See Figure 70)

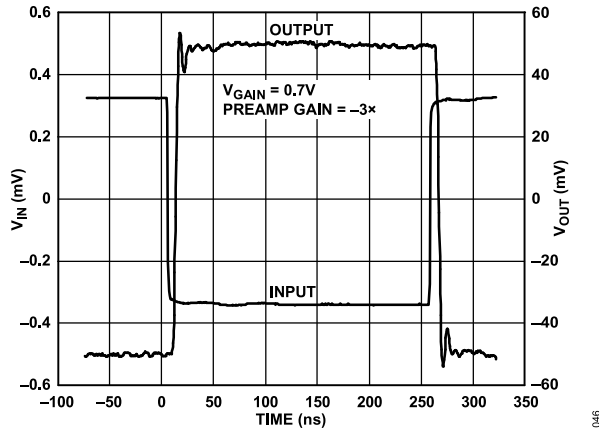

Figure 46. Inverting Gain Small-Signal Pulse Response (See Figure 70)

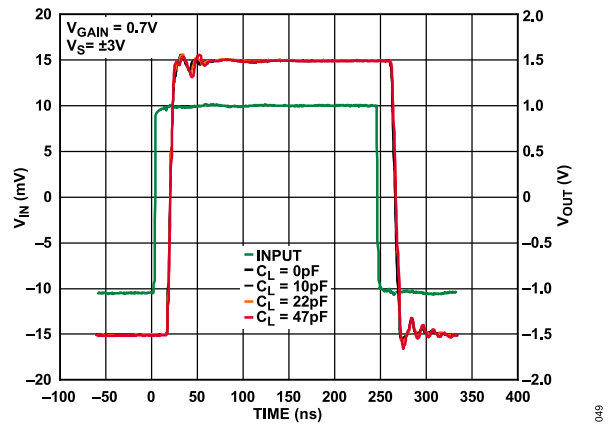

Figure 49. Large-Signal Pulse Response for Various Values of Load Capacitance Using ± 3 V Power Supplies (See Figure 65)

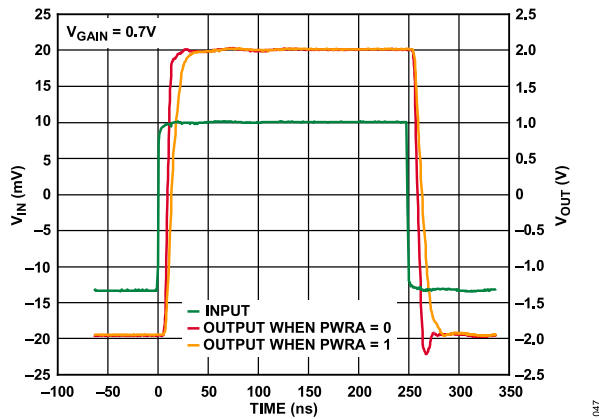

Figure 47. Large-Signal Pulse Response for Both Power Levels (See Figure 65)

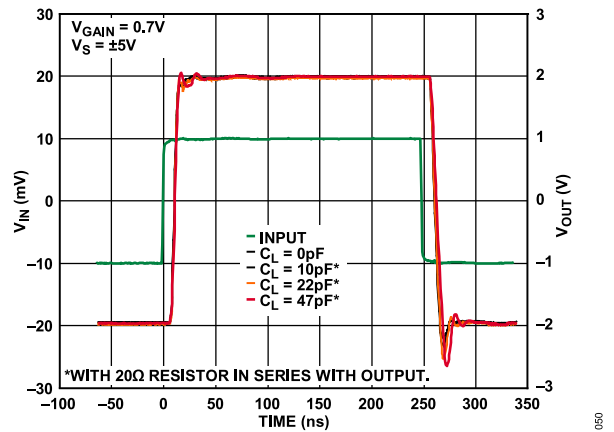

Figure 50. Large-Signal Pulse Response for Various Values of Load Capacitance Using ± 5 V Power Supplies (See Figure 65)

TYPICAL PERFORMANCE CHARACTERISTICS

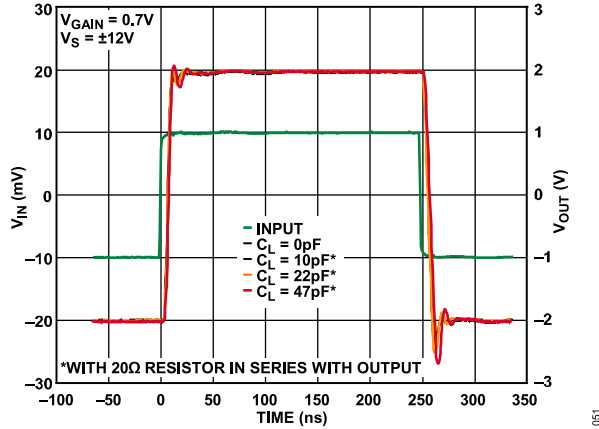

Figure 51. Large-Signal Pulse Response for Various Values of Load Capacitance Using ± 12 V Power Supplies (See Figure 65)

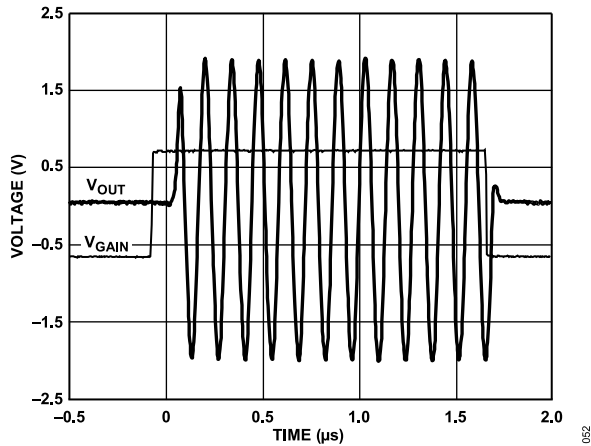

Figure 52. Gain Response (See Figure 66)

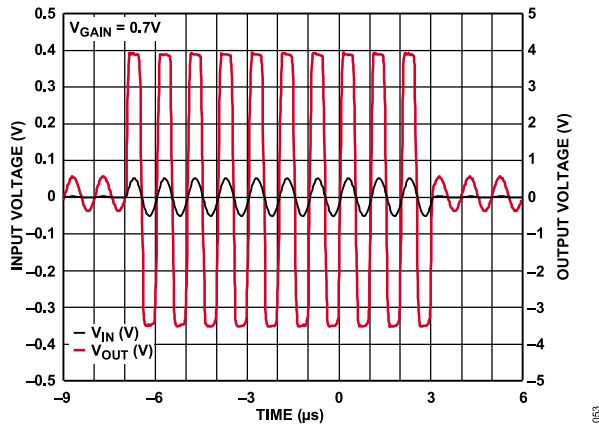

Figure 53. VGA Overdrive Recovery (See Figure 67)

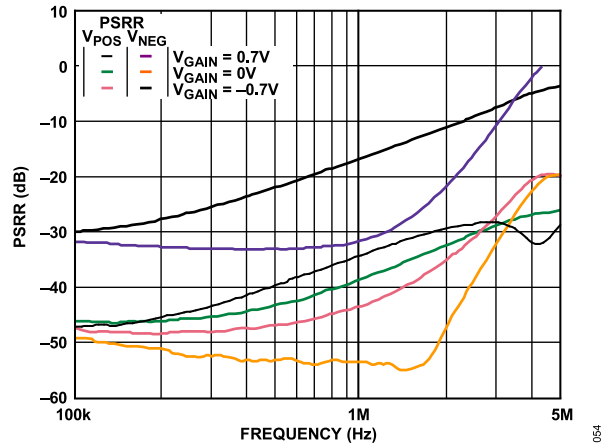

Figure 54. PSRR vs. Frequency for Three Values of V_{GAIN} (See Figure 71)

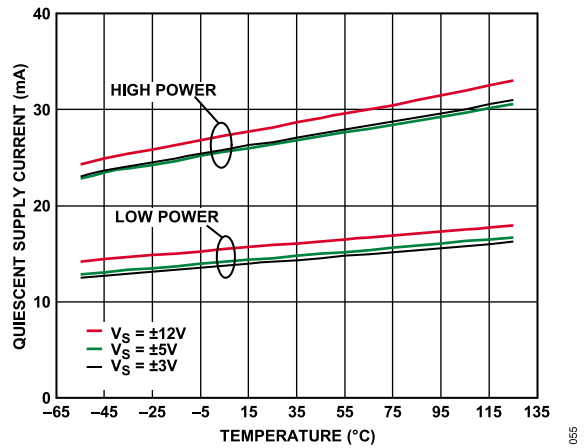

Figure 55. I_Q vs. Temperature for Three Values of Supply Voltage and High and Low Power (See Figure 68)

TEST CIRCUITS

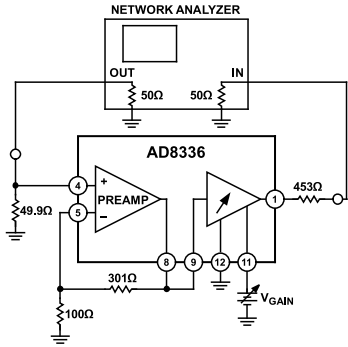

Figure 56. Gain vs. V_{GAIN} and Gain Error vs. V_{GAIN}

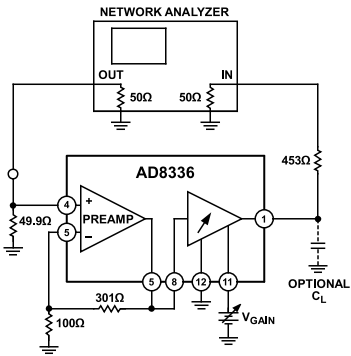

Figure 57. Frequency Response

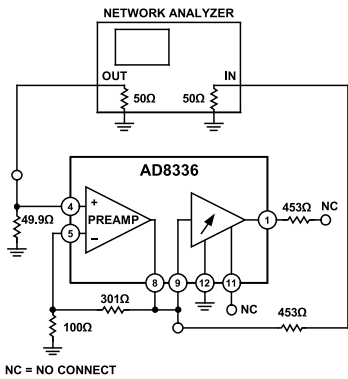

Figure 58. Frequency Response of the Preamplifier

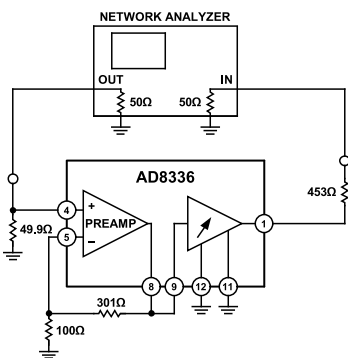

Figure 59. Group Delay

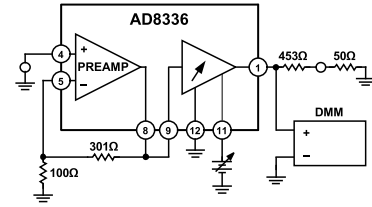

Figure 60. Offset Voltage

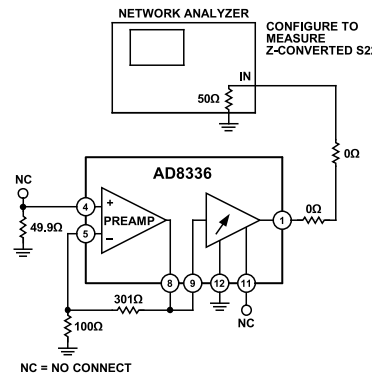

Figure 61. Output Resistance vs. Frequency

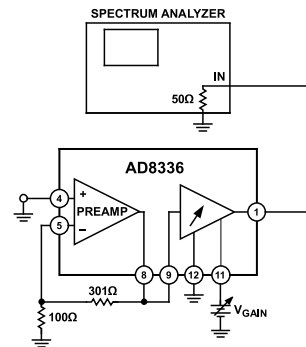

Figure 62. Input-Referred Noise and Output-Referred Noise

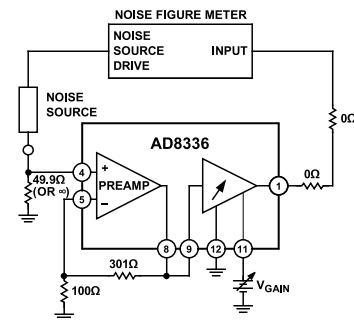

Figure 63. Noise Figure vs. V_{GAIN}

TEST CIRCUITS

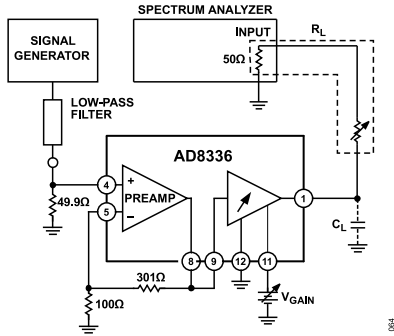

Figure 64. Harmonic Distortion

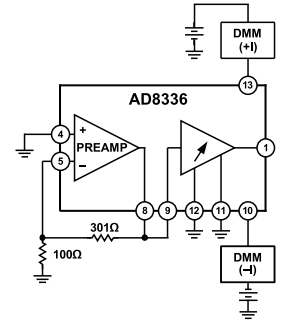

Figure 68. Supply Current

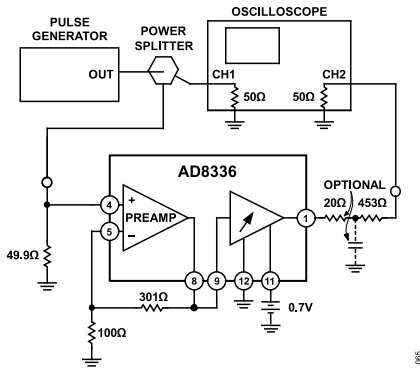

Figure 65. Pulse Response

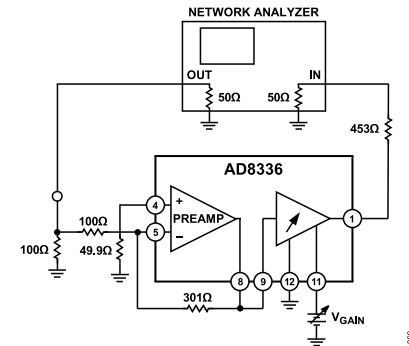

Figure 69. Frequency Response, Inverting Gain

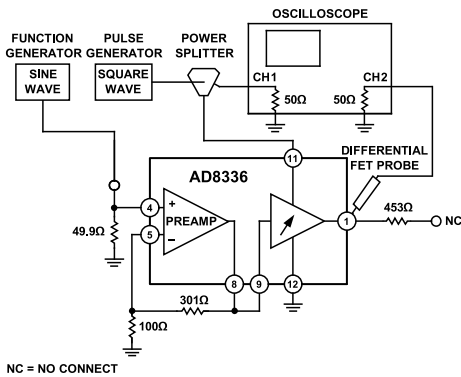

Figure 66. Gain Response

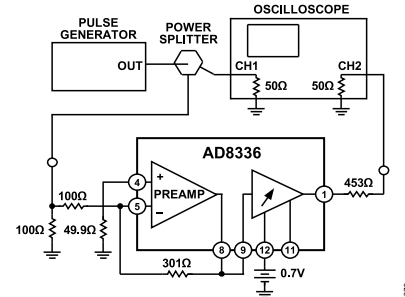

Figure 70. Pulse Response, Inverting Gain

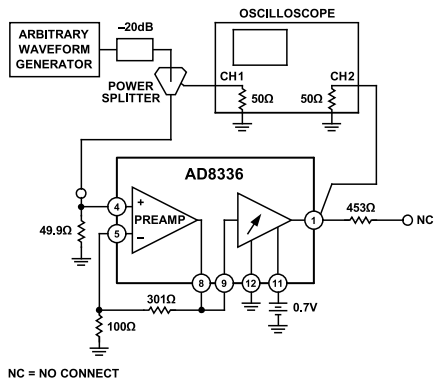

Figure 67. VGA Overdrive Recovery

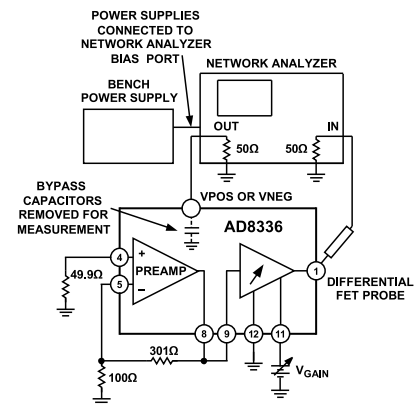

Figure 71. PSRR

TEST CIRCUITS

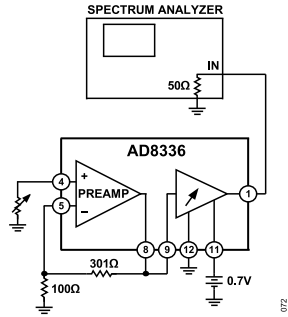

Figure 72. Input-Referred Noise vs. Source Resistance

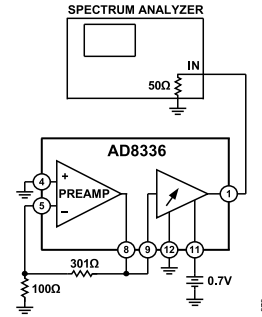

Figure 73. Short-Circuit Input-Referred Noise vs. Frequency

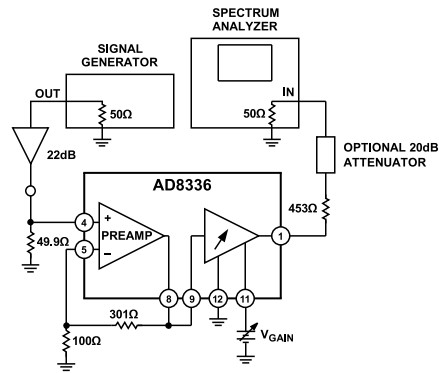

Figure 74. $IP1dB$ vs. V_{GAIN}

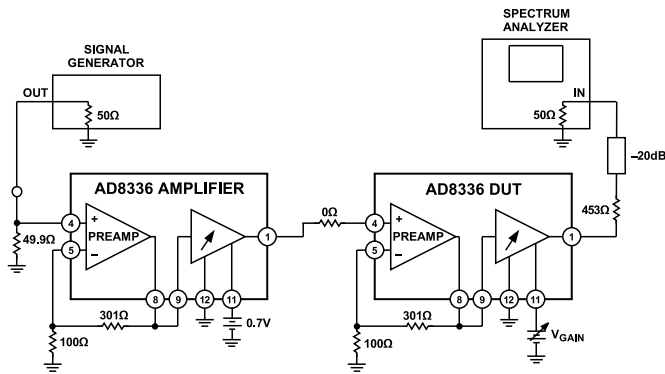

Figure 75. $IP1dB$ vs. V_{GAIN} , High Signal Level Inputs

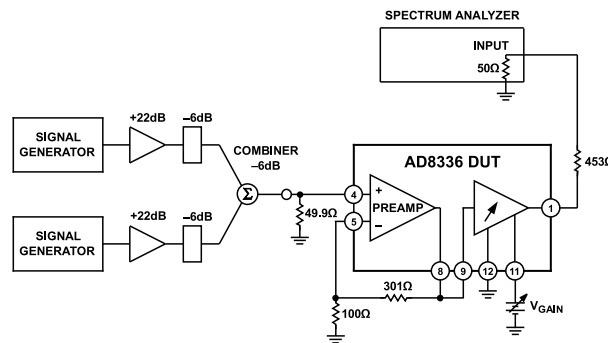

Figure 76. IMD and OIP3

THEORY OF OPERATION

OVERVIEW

The AD8336 is the first VGA designed for operation over exceptionally broad ranges of temperature and supply voltage. The performance has been characterized from temperatures extending from -55°C to $+125^{\circ}\text{C}$, and supply voltages from $\pm 3\text{ V}$ to $\pm 12\text{ V}$. It is ideal for applications requiring dc coupling, large output voltage swings, very large gain ranges, extreme temperature variations, or a combination thereof.

The simplified block diagram is shown in Figure 77. The AD8336 includes a voltage feedback preamplifier, an amplifier with a fixed gain of 34 dB, a 60 dB attenuator, and various bias and interface circuitry. The independent voltage feedback operational amplifier can be used in noninverting and inverting configurations and functions as a preamplifier to the variable gain amplifier (VGA). If desired, the preamplifier output (PRAO) and VGA input (VGAI) pins provide for connection of an interstage filter to eliminate noise and offset. The bandwidth of the AD8336 is dc to 100 MHz with a gain range of 60 dB (-14 dB to $+46\text{ dB}$).

For applications that require large supply voltages, a reduction in power is advantageous. The power reduction pin (PWRA) permits the power and bandwidth to be reduced by about half in such applications.

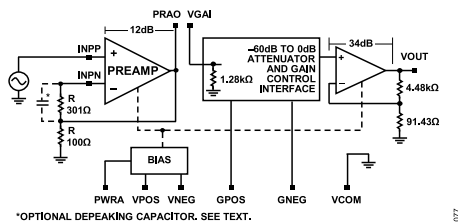

Figure 77. Simplified Block Diagram

To maintain low noise, the output stages of both the preamplifier and the VGA are capable of driving relatively small load resistances. However, at the largest supply voltages, the signal current can exceed safe operating limits for the amplifiers and, therefore, the load current must not exceed 50 mA. With a $\pm 12\text{ V}$ supply and $\pm 10\text{ V}$ output voltage at the preamplifier or VGA output, load resistances as low as $200\ \Omega$ are acceptable.

For power supply voltages $\geq \pm 10\text{ V}$, the maximum operating temperature range is derated to $+85^{\circ}\text{C}$ because the power can exceed safe limits (see the [Absolute Maximum Ratings](#) section).

Because harmonic distortion products can increase for various combinations of low impedance loads and high output voltage swings, it is recommended that the user determine load and drive conditions empirically.

PREAMPLIFIER

The gain of the uncommitted voltage feedback preamplifier is set with external resistors. The combined preamplifier and VGA gain is specified in two ranges: -14 dB to $+46\text{ dB}$ and 0 dB to 60 dB .

Since the VGA gain is fixed at 34 dB ($50\times$), the preamplifier gain is adjusted for gains of 12 dB ($4\times$) and 26 dB ($200\times$).

With low preamplifier gains between $2\times$ and $4\times$, it can be desirable to reduce the high frequency gain with a shunt capacitor across R_{FB2} to ameliorate peaking in the frequency domain (see [Figure 77](#)). To maintain stability, the gain of the preamplifier must be 6 dB ($2\times$) or greater.

Typical of voltage feedback amplifier configurations, the gain-bandwidth product of the AD8336 is fixed (at 600); therefore, the bandwidth decreases as the gain is increased beyond the nominal gain value of $4\times$. For example, if the preamplifier gain is increased to $20\times$, the bandwidth reduces by a factor of 5 to about 20 MHz. The -3 dB bandwidth of the preamplifier with a gain of $4\times$ is about 150 MHz, and for the $20\times$ gain is about 30 MHz.

The preamplifier gain diminishes for an amplifier configured for inverting gain, using the same value of feedback resistors as for a noninverting amplifier, but the bandwidth remains unchanged. For example, if the noninverting gain is $4\times$, the inverting gain is $-3\times$, but the bandwidth stays the same as in the noninverting gain of $4\times$. However, because the output-referred noise of the preamplifier is the same in both cases, the input-referred noise increases as the ratio of the two gain values increases. For the previous example, the input-referred noise increases by a factor of 4/3.

The output swing of the preamplifier is the same as for the VGA.

VGA

The architecture of the variable gain amplifier (VGA) section of the AD8336 is based on the Analog Devices, Inc., X-AMP (exponential amplifier), found in a wide variety of Analog Devices variable gain amplifiers. This type of VGA combines a ladder attenuator and interpolator, followed by a fixed-gain amplifier.

The gain control interface is fully differential, permitting positive or negative gain slopes. Note that the common-mode voltage of the gain control inputs increases with increasing supply.

The gain slope is 50 dB/V and the intercept is 16.4 dB when the nominal preamplifier gain is $4\times$ (12 dB). The intercept changes with the preamplifier gain; for example, when the preamplifier gain is set to $20\times$ (26 dB), the intercept becomes 30.4 dB.

Pin VGAI is connected to the input of the ladder attenuator. The ladder ratio is $R/2R$ and the nominal resistance is $320\ \Omega$. To reduce preamplifier loading and large-signal dissipation, the input resistance at Pin VGAI is $1.28\text{ k}\Omega$. Safe current density and power dissipation levels are maintained even when large dc signals are applied to the ladder.

The tap resistance of the resistors within the $R/2R$ ladder is $640\ \Omega/3$, or $213.3\ \Omega$, and is the Johnson noise source of the attenuator.

THEORY OF OPERATION

SETTING THE GAIN

The overall gain of the AD8336 is the sum (in decibels) or the product (magnitude) of the preamplifier gain and the VGA gain. The preamplifier gain is calculated as with any operational amplifier, as seen in the [Applications Information](#) section. It is most convenient to think of the device gain in exponential terms (that is, in decibels) since the VGA responds linearly in decibels with changes in control voltage V_{GAIN} at the gain pins.

The gain equation for the VGA is

$$VGA \text{ Gain (dB)} = \left[V_{GAIN}(V) \times \frac{50 \text{ dB}}{V} \right] + 4.4 \text{ dB}$$

where $V_{GAIN} = V_{GPOS} - V_{GNEG}$.

The gain and gain range of the VGA are both fixed at 34 dB and 60 dB, respectively; thus, the composite device gain is changed by adjusting the preamplifier gain. For a preamplifier gain of 12 dB (4 \times), the composite gain is -14 dB to +46 dB. Therefore, the calculation for the composite gain (in decibels) is

$$\text{Composite Gain} = G_{PRA} + [V_{GAIN}(V) \times 49.9 \text{ dB/V}] + 4.4 \text{ dB}$$

For example, the midpoint gain when the preamplifier gain is 12 dB is

$$12 \text{ dB} + [0 \text{ V} \times 49.9 \text{ dB/V}] + 4.4 \text{ dB} = 16.4 \text{ dB}$$

[Figure 3](#) is a plot of gain in decibels vs. V_{GAIN} in millivolts, when the preamplifier gain is 12 dB (4 \times). Note that the computed result closely matches the plot of actual gain.

In [Figure 3](#), the gain slope flattens at the limits of the V_{GAIN} input. The gain response is linear in dB over the center 80% of the control range of the device. [Figure 78](#) shows the ideal gain characteristics for the VGA stage gain, the composite gain, and the preamplifier gain.

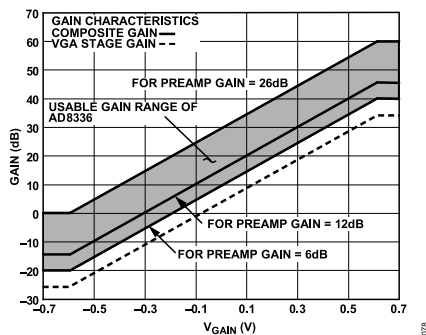

Figure 78. Ideal Gain Characteristics of the AD8336

NOISE

The noise of the AD8336 is dependent on the value of the VGA gain. At maximum V_{GAIN} , the dominant noise source is the preamplifier, but it shifts to the VGA as V_{GAIN} diminishes.

The input-referred noise at the highest VGA gain and a preamplifier gain of 4 \times , with $R_{FB1} = 100 \Omega$ and $R_{FB2} = 301 \Omega$, is 3 nV/ $\sqrt{\text{Hz}}$ and is determined by the preamplifier and the gain setting resistors. See [Table 4](#) for the noise components for the preamplifier.

Table 4. AD8336 Noise Components for Preamplifier Gain = 4 \times

Noise Component	Noise Voltage (nV/ $\sqrt{\text{Hz}}$)
Op Amp (Gain = 4 \times)	2.6
$R_{FB1} = 100 \Omega$	0.96
$R_{FB2} = 301 \Omega$	0.55
VGA	0.77

Using the values listed in [Table 4](#), the total noise of the AD8336 is slightly less than 3 nV/ $\sqrt{\text{Hz}}$, referred to the input. Although the input noise referred to the VGA is 3.1 nV/ $\sqrt{\text{Hz}}$, the input-referred noise at the preamplifier is 0.77 nV/ $\sqrt{\text{Hz}}$ when divided by the preamplifier gain of 4 \times .

At other than maximum gain, the noise of the VGA is determined from the output noise. The noise in the center of the gain range is about 150 nV/ $\sqrt{\text{Hz}}$. Because the gain of the fixed-gain amplifier that is part of the VGA is 50 \times , the VGA input-referred noise is approximately 3 nV/ $\sqrt{\text{Hz}}$, the same value as the preamplifier and VGA combined. This is expected since the input-referred noise is the same at the input of the attenuator at maximum gain. However, the noise referred to the VGAI pin (the preamplifier output) increases by the amount of attenuation through the ladder network. The noise at any point along the ladder network is primarily composed of the ladder resistance noise, the noise of the input devices, and the feedback resistor network noise. The ladder network and the input devices are the largest noise sources.

At minimum gain, the output noise increases slightly to about 180 nV/ $\sqrt{\text{Hz}}$ because of the finite structure of the X-AMP.

OFFSET VOLTAGE

Extensive cancellation circuitry included in the variable gain amplifier section minimizes locally generated offset voltages. However, when operated at very large values of gain, dc voltage errors at the output can still result from small dc input voltages. When configured for the nominal gain range of -14 dB to +46 dB, the maximum gain is 200 \times and an offset of only 100 μV at the input generates 20 mV at the output.

The primary source for dc offset errors is the preamplifier; ac coupling between the PRAO and VGAI pins is the simplest solution. In applications where dc coupling is essential, a compensating current can be injected at the INPN input (Pin 5) to cancel preamplifier offset. The direction of the compensating current depends on the polarity of the offset voltage.

APPLICATIONS INFORMATION

AMPLIFIER CONFIGURATION

The AD8336 amplifiers can be configured in various options. In addition to the 60 dB gain range variable gain stage, an uncommitted voltage gain amplifier is available to the user as a preamplifier. The preamplifier connections are separate to enable noninverting or inverting gain configurations or the use of interstage filtering. The AD8336 can be used as a cascade connected VGA with preamp input, as a standalone VGA, or as a standalone preamplifier. This section describes some of the possible applications.

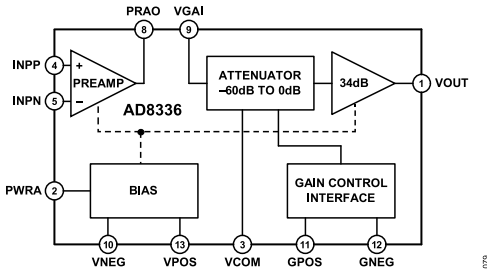

Figure 79. Application Block Diagram

PREAMPLIFIER

While observing just a few constraints, the uncommitted voltage feedback preamplifier of the AD8336 can be connected in a variety of standard high frequency operational amplifier configurations. The amplifier is optimized for a gain of 4x (12 dB) and has a gain bandwidth product of 600 MHz. At a gain of 4x, the bandwidth is 150 MHz. The preamplifier gain can be adjusted to a minimum gain of 2x; however, there will be a small peak in the response at high frequencies. At higher preamplifier gains, the bandwidth diminishes proportionally in conformance to the classical voltage gain amplifier GBW relationship.

While setting the overall gain of the AD8336, the user must consider the input-referred offset voltage of the preamplifier. Although the offset of the attenuator and postamplifier are almost negligible, the preamplifier offset voltage, if uncorrected, is increased by the combined gain of the preamplifier and post-amplifier. Therefore, for a maximum gain of 60 dB, an input offset voltage of only 200 μV results in an error of 200 mV at the output.

Circuit Configuration for Noninverting Gain

The noninverting configuration is shown in Figure 80. The preamplifier gain is described by the classical operational amplifier gain equation:

$$Gain = \frac{R_{FB2}}{R_{FB1}} + 1$$

The practical gain limits for this amplifier are 6 dB to 26 dB. The gain bandwidth product is about 600 MHz, so at 150 MHz, the maximum achievable gain is 12 dB (4x). The minimum gain is established internally by fixed loop compensation and is 6 dB (2x). This amplifier is not designed for unity-gain operation. Table

5 shows the gain and bandwidth for the noninverting gain configuration.

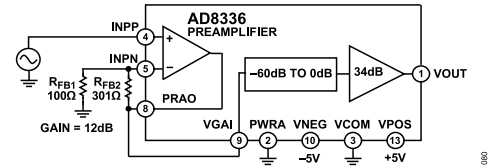

Figure 80. Circuit Configuration for Noninverting Gain

The preamplifier output reliably sources and sinks currents up to 50 mA. When using ±5 V power supplies, the suggested sum of the output resistor values is 400 Ω total for the optimal trade-off between distortion and noise. Much of the low gain value device characterization was performed with resistor values of 301 Ω and 100 Ω, resulting in a preamplifier gain of 12 dB (4x). With supply voltages between ±5 V and ±12 V, the sum of the output resistance must be increased accordingly; a total resistance of 1 kΩ is recommended. Larger resistance values, subject to a trade-off in higher noise performance, can be used if circuit power and load driving are issues. When considering the total power dissipation, remember that the input ladder resistance of the VGA is part of the preamplifier load.

Table 5. Gain and Bandwidth for Noninverting Preamplifier Configuration

Preamplifier Gain		Preamplifier BW	
Numerical	dB	(MHz)	Composite Gain (dB)
4x	12	150	-14 to +46
8x	18	60	-8 to +52
16x	24	30	-2 to +58
20x	26	25	0 to +60

Circuit Configuration for Inverting Gain

The preamplifier can also be used in an inverting configuration, as shown in Figure 81.

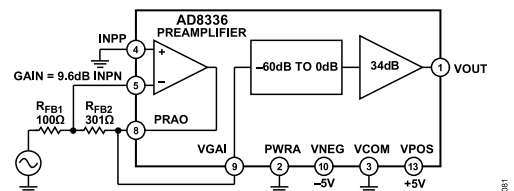

Figure 81. Circuit Configuration for Inverting Gain

The considerations regarding total resistance vs. distortion, noise, and power that were noted in the noninverting case also apply in the inverting case, except that the amplifier can be operated at unity inverting gain. The signal gain is reduced while the noise gain is the same as for the noninverting configuration:

$$Signal\ Gain = \frac{R_{FB2}}{R_{FB1}}$$

and

APPLICATIONS INFORMATION

$$\text{Noise Gain} = \frac{R_{FB2}}{R_{FB1}} + 1$$

USING THE POWER ADJUST FEATURE

The AD8336 has the provision to operate at lower power with a trade-off in bandwidth. The power reduction applies to the preamplifier and the VGA sections, and the bandwidth is reduced equally between them. Reducing the power is particularly useful when operating with higher supply voltages and lower values of output loading that otherwise stresses the output amplifiers. When Pin PWRA is grounded, the amplifiers operate in their default mode, and the combined 3 dB bandwidth is 80 MHz with the preamplifier gain adjusted to 4×. When the voltage on Pin PWRA is between 1.2 V and 5 V, the power is reduced by approximately half and the 3 dB bandwidth reduces to approximately 35 MHz. The voltage at Pin PWRA must not exceed 5 V.

DRIVING CAPACITIVE LOADS

The output stages of the AD8336 are stable with capacitive loads up to 47 pF for a supply voltage of ±3 V and with capacitive loads up to 10 pF for supply voltages up to ±8 V. For larger combined values of load capacitance and/or supply voltage, a 20 Ω series resistor is recommended for stability.

The influence of capacitance and supply voltage are shown in [Figure 50](#) and [Figure 51](#), where representative combinations of load capacitance and supply voltage requiring a 20 Ω resistor are marked with an asterisk. No resistor is required for the ±3 V plots in [Figure 49](#), but a resistor is required for most of the ±12 V plots in [Figure 51](#).

EVALUATION BOARD

An evaluation board, [AD8336-EVALZ](#), is available online for the AD8336. [Figure 82](#) is a photo of the board.

The board is shipped from the factory configured for a non-inverting preamplifier gain of 4×. To change the value of the gain of the preamplifier or to change the gain polarity to inverting, alter the component values or install components in the alternate locations provided. All components are standard 0603 size, and the board is compliant with RoHS requirements. [Table 6](#) shows the components to be removed and added to change the amplifier configuration to inverting gain.

Table 6. Component Changes for Inverting Configuration

Remove	Install
R4, R7	R5, R6

OPTIONAL CIRCUITRY

The AD8336 features differential inputs for the gain control, permitting nonzero or floating gain control inputs. To avoid any delay in making the board operational, the gain input circuit is shipped with Pin GNEG connected to ground via a 0 Ω resistor in the R17 location. The user can adjust the gain of the device by driving the GPOS test loop with a power supply or voltage reference. Optional resistor networks R15/R17 and R13/R14 provide fixed-gain bias voltages at Pin GNEG and Pin GPOS for non-zero common-mode voltages. The gain control can also be driven with an active input such as a ramp. Provision is made for an optional SMA connector at PRVG for monitoring the preamplifier output or for driving the VGA from an external source. Remove the 0 Ω resistor at R9 to isolate the preamplifier from an external generator. The capacitor at Location C1 limits the bandwidth of the preamplifier.

BOARD LAYOUT CONSIDERATIONS

The evaluation board uses four layers, with power and ground planes located between two conductor layers. This arrangement is highly recommended for customers, and several views of the board are provided as reference for board layout details. When laying out a printed circuit board for the AD8336, remember to provide a pad beneath the device to solder the exposed pad of the matching device. The pad in the board must have at least five vias to provide a thermal path for the chip scale package. Unlike leaded devices, the thermal pad is the primary means to remove heat dissipated within the device.

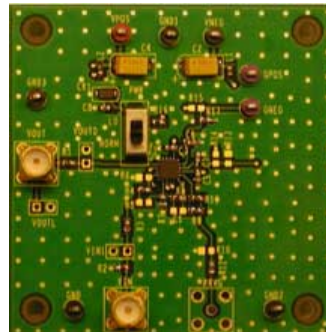

Figure 82. AD8336 Evaluation Board

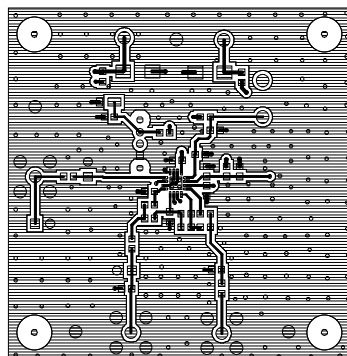

Figure 83. Component Side Copper

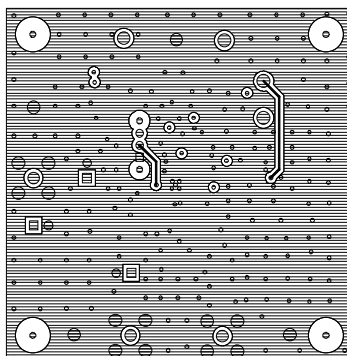

Figure 84. Secondary Side Copper

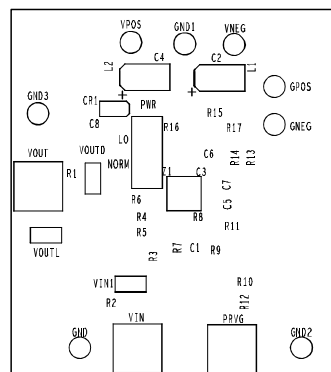

Figure 85. Component Side Silkscreen

OUTLINE DIMENSIONS

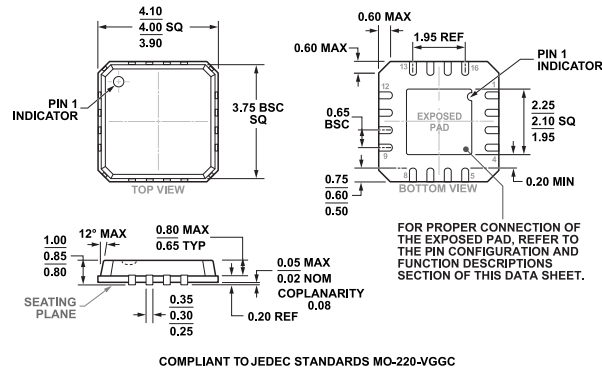

Figure 89. 16-Lead Lead Frame Chip Scale Package [LFCSP]
 4 mm x 4 mm Body and 0.85 mm Package Height
 (CP-16-4)
 Dimensions shown in millimeters

Updated: March 31, 2022

ORDERING GUIDE

Model ¹	Temperature Range	Package Description	Packing Quantity	Package Option
AD8336ACPZ-R7	-40°C to +85°C	16-Lead LFCSP (4mm x 4mm x 0.85mm w/ EP)	Reel, 1500	CP-16-4
AD8336ACPZ-RL	-40°C to +85°C	16-Lead LFCSP (4mm x 4mm x 0.85mm w/ EP)	Reel, 5000	CP-16-4
AD8336ACPZ-WP	-40°C to +85°C	16-Lead LFCSP (4mm x 4mm x 0.85mm w/ EP)	Tray	CP-16-4

¹ Z = RoHS Compliant Part.

EVALUATION BOARDS

Model ¹	Description
AD8336-EVALZ	Evaluation Board

¹ Z = RoHS Compliant Part.

Looking for pricing, stock, or lifecycle information?

Click below to explore more details on WIN SOURCE:

 [View AD8336ACPZ-R7 on WIN SOURCE](#)

 [Analog Devices Inc. Information](#)

Optimize Your Supply Chain with WIN SOURCE Solutions

-  Global Sourcing Solution
-  Obsolete Management
-  Cost Control Management
-  Shortage Management
-  Alternative Solution
-  Excess Inventory Management