



**THE DATASHEET OF
88LX5153A0-BUU2C000**



2Gbps G.hn MAC/PHY Transceiver Solutions for Networking over Powerlines, Phone Lines and Coaxial Cable

OVERVIEW

Evaluation Kits

DW920	Powerline EVK
DCP962C	Coax EVK
DCP962P	Phone Line EVK

Supporting ICs

88LX5152	DBB for Powerline
88LX5153/ 88LX5153A	DBB for Coax/ Powerline/Phone Line
88LX2720	AFE for Powerline
88LX2730	AFE for Coax/Phone Line
88LX2741	AFE for Coax/Powerline/ Phone Line

FEATURES

- Coaxial Cable Performance
 - PHY rate up to 2Gbps
 - Max. throughput 1.7Gbps
- Phone Line (Twisted Pair) Performance
 - PHY rate up to 2Gbps
 - Max. throughput 1.7Gbps
- Powerline Performance
 - PHY rate up to 1.5Gbps
 - Max. throughput 1.0Gbps
- Data Interfaces
 - RGMII (1G)
 - SGMII (1G/2.5G)
- ITU-T Compliant with G.9960/61/62/63/64
- Commercial and Industrial temperature range
- 88LX5152 / 88LX5153 / 88LX5153A
 - 10mm x 10mm BGA186
- 88LX2720 / 88LX2730 / 88LX2741
 - 4mm x 4mm QFN28

BENEFITS

- Faster net throughput versus competing solutions
- Spirit SDK (Software Development Kit) enables customized solutions with fast time-to-market
- End-to-end 128-bit AES CCMP encryption enables added security
- LDPC forward error correction, and other enhanced features enable reliable data delivery and robust performance in noisy environments

Gigabit Speeds Over Existing Wires

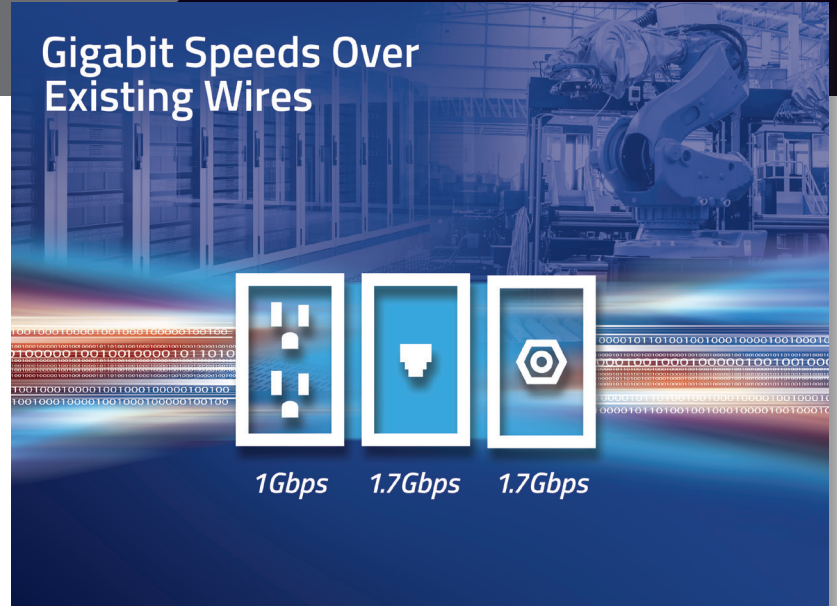

The MaxLinear G.hn Wave-2 Product Family provides high-speed networking capabilities over any wired medium including powerlines, phone lines/twisted-pair and coax cables. With physical data rates up to 2Gbps, the MaxLinear G.hn Wave-2 platform is the fastest G.hn solution in the industry.

The G.hn Wave-2 product family is compliant with the latest version of the ITU-T G.hn standard (Recommendations G.9960, G.9961, G.9962, G.9963 and G.9964). It also includes support for 200MHz coaxial; 200MHz phone line SISO, 100MHz phone line MIMO; and 100MHz powerline MIMO. By using MaxLinear G.hn Wave-2 solutions, system designers can build products that easily achieve HomeGrid Forum certification for G.hn compliance.

This networking solution achieves gigabit performance and includes three options for G.hn digital baseband (DBB) processor (88LX5152, 88LX5153 and 88LX5153A) and three options for G.hn analog front end (AFE) (88LX2720, 88LX2730, and 88LX2741). The product family provides system designers the flexibility to mix and match footprint-compatible components to address multiple G.hn applications in the consumer, broadband, industrial and security segments.

G.hn Wave-2 Networking Products

APPLICATIONS

- Home Networking & Broadband
 - Gateways, Routers, STBs, WiFi Extenders
- Factory Automation
- Smart Buildings
 - Smart Elevators, Door Security Systems
- Smart Grid and Smart Metering
- Smart Cities
 - Security Cameras, Intelligent Street Lights

The G.hn baseband processors include the G.hn PHY (physical layer), G.hn DLL (data link layer), embedded CPU for control and management purposes, embedded memory and two Ethernet interface options: either RGMII (1 Gbps) or SGMII (1Gbps and 2.5Gbps).

The G.hn AFEs provide programmable transmit and receive paths optimized for each physical medium, with 88LX2720 supporting powerline applications; 88LX2730 supporting coax cables and twisted-pair applications; and 88LX2741 supporting powerline, coax cable and twisted-pair applications over the industrial temperature range.

MaxLinear provides several turn-key software packages (codenamed Spirit) that enable customers to quickly go to market with a fully functional product that meets key requirements such as IPv4/IPv6 support, QoS, TR-069 management, IGMP/MLD snooping and HomeGrid Forum certification. Customers can also use the Spirit SDK to develop customized applications that run on the embedded CPU.

An evaluation kit is available for each wired medium; powerline, phone line/twisted-pair and coaxial cable. These kits include everything needed to evaluate the real world performance of our industry leading G.hn technology.

Powerline MIMO (100MHz)

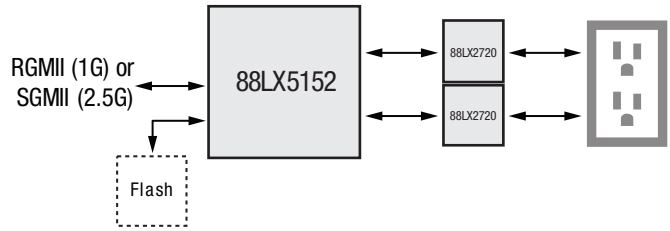

Coax (200MHz)

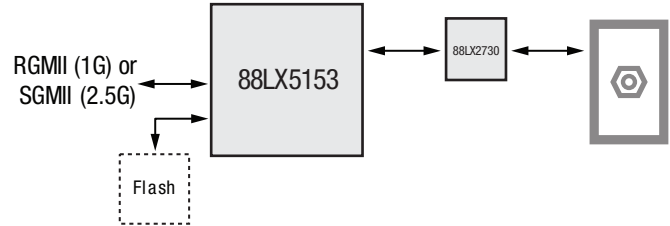

Phone Line SISO (200MHz)

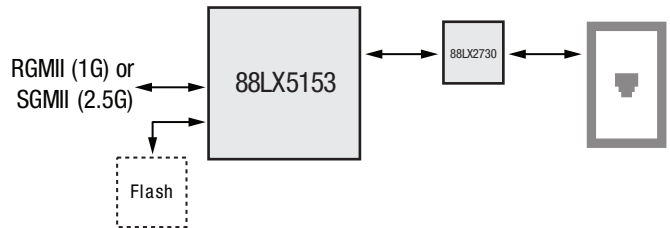

Bonded Phone Line MIMO (100MHz)

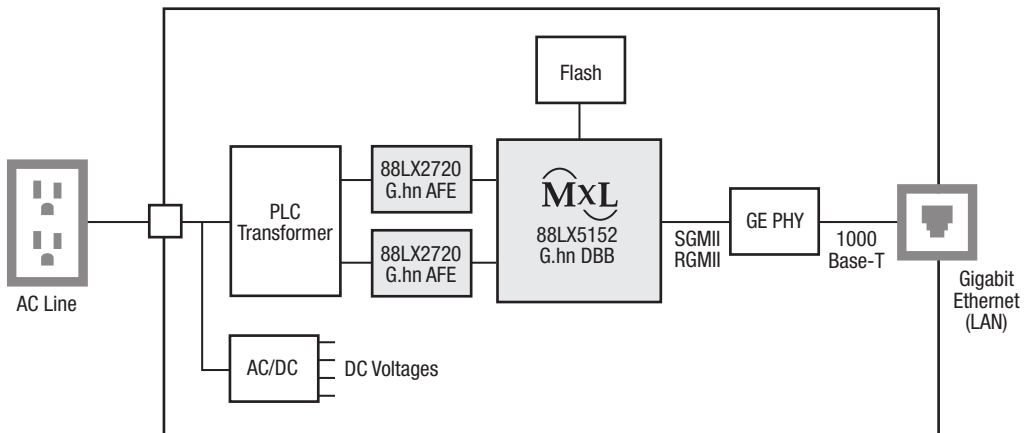
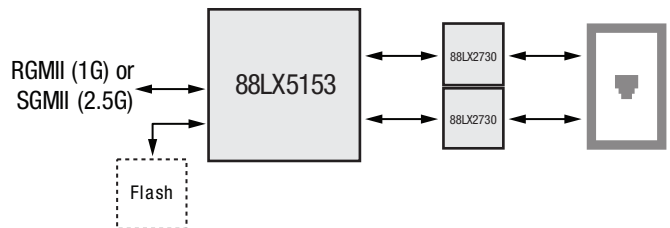

Application Example: Powerline/Ethernet Adapter

G.hn Wave-2 Networking Products

G.hn Wave-2 Networking Products

Part Number	Function	Ch.	Physical Medium	Supported G.hn Profiles	Max Net Throughput (Gbps)	Data Interfaces	Ordering Part Number ⁽¹⁾	Temp Range ⁽²⁾ (°C)	Package ⁽³⁾ (mm)
88LX5152	Baseband	2	Powerline	MIMO 100MHz, SISO 100MHz	1	RGMII (1G), SGMII (1G/2.5G)	88LX5152A0-BUU2C000	0 to 70	10 x 10 BGA-186
88LX5153	Baseband	2	Powerline	MIMO 100MHz, SISO 100MHz	1	RGMII (1G), SGMII (1G/2.5G)	88LX5153A0-BUU2C000	0 to 70	10 x 10 BGA-186
			Phone Line	SISO 200MHz, MIMO 100MHz	1.7				
			Coaxial	Coaxial 200MHz	1.7				
88LX5153A	Baseband	2	Powerline	MIMO 100MHz, SISO 100MHz	1	RGMII (1G), SGMII (1G/2.5G)	88LX5153A0-BUU2I000	-40 to 70	10 x 10 BGA-186
			Phone Line	SISO 200MHz, MIMO 100MHz	1.7				
			Coaxial	Coaxial 200MHz	1.7				
88LX2720	Analog Front End	1	Powerline	MIMO 100MHz, SISO 100MHz	N/A	N/A	88LX2720A0-NYC2C000	0 to 70	4 x 4 QFN-28
88LX2730	Analog Front End	1	Coaxial	SISO 200MHz	N/A	N/A	88LX2730A0-NYC2C000	0 to 70	4 x 4 QFN-28
			Phone Line	SISO 200MHz, MIMO 100MHz	N/A				
88LX2741	Analog Front End	1	Powerline	MIMO 100MHz, SISO 100MHz	N/A	N/A	88LX2741A0-NYC2I000	-40 to 70	4 x 4 QFN-28
			Coaxial	SISO 200MHz	N/A				
			Phone Line	SISO 200MHz, MIMO 100MHz	N/A				

1. Refer to individual product pages on www.exar.com, for most up-to-date Ordering Information.

2. Ambient temperature range.

3. Lead-free, visit www.exar.com for additional information on Environmental Rating.

G.hn Wave-2 Networking Evaluation Kits

Eval Kit	Physical Medium	Supported G.hn Profiles	Max Net Throughput	Data Interfaces	Baseband Chip Used	Analog Front-End Used	Kit Ordering Number ⁽¹⁾	# of Boards in Kit	Temp Range (°C)
DW920	Powerline (110/220V AC)	MIMO 100MHz, SISO 100MHz	1000Mbps	1000Base-T	88LX5152	88LX2720 (2x)	RD-HNPLC-2DW920KIT01	2	0-40
DGP962C	Coaxial (F-Connector)	Coaxial 200MHz	1700Mbps	1000Base-T, SFP	88LX5153	88LX2730	RD-HNCOAX2DGP962CKIT	2	0-40
DGP962P	Phone Line (RJ-11/RJ-45)	MIMO 100MHz, SISO 200MHz	1700Mbps	1000Base-T, SFP	88LX5153	88LX2730 (2x)	RD-HNPH2DGP962KIT-01	2	0-40

1. Refer to individual product pages on www.exar.com, for most up-to-date Ordering Information.

G.hn Wave-2 Networking Products

G.hn Wave-2 Networking Evaluation Kits (Continued)



Powerline Networking Evaluation Kit #DW920



Coaxial Networking Evaluation Kit #DCP962C



Phone Line Networking Evaluation Kit #DCP962P



Corporate Headquarters:
5966 La Place Court
Suite 100
Carlsbad, CA 92008
Tel.: +1 (760) 692-0711
Fax: +1 (760) 444-8598
www.maxlinear.com

The content of this document is furnished for informational use only, is subject to change without notice, and should not be construed as a commitment by MaxLinear, Inc.. MaxLinear, Inc. assumes no responsibility or liability for any errors or inaccuracies that may appear in the informational content contained in this guide. Complying with all applicable copyright laws is the responsibility of the user. Without limiting the rights under copyright, no part of this document may be reproduced into, stored in, or introduced into a retrieval system, or transmitted in any form or by any means (electronic, mechanical, photocopying, recording, or otherwise), or for any purpose, without the express written permission of MaxLinear, Inc.

Maxlinear, Inc. does not recommend the use of any of its products in life support applications where the failure or malfunction of the product can reasonably be expected to cause failure of the life support system or to significantly affect its safety or effectiveness. Products are not authorized for use in such applications unless MaxLinear, Inc. receives, in writing, assurances to its satisfaction that: (a) the risk of injury or damage has been minimized; (b) the user assumes all such risks; (c) potential liability of MaxLinear, Inc. is adequately protected under the circumstances.

MaxLinear, Inc. may have patents, patent applications, trademarks, copyrights, or other intellectual property rights covering subject matter in this document. Except as expressly provided in any written license agreement from MaxLinear, Inc., the furnishing of this document does not give you any license to these patents, trademarks, copyrights, or other intellectual property.



Company and product names may be registered trademarks or trademarks of the respective owners with which they are associated.

© 2018 MaxLinear, Inc. All rights reserved

MxLG.hnWave2_FL_0818

Looking for pricing, stock, or lifecycle information?

Click below to explore more details on WIN SOURCE:

-  [View 88LX5153A0-BUU2C000 on WIN SOURCE](#)
-  [Exar Corporation](#) Information

Optimize Your Supply Chain with WIN SOURCE Solutions

-  Global Sourcing Solution
-  Obsolete Management
-  Cost Control Management
-  Shortage Management
-  Alternative Solution
-  Excess Inventory Management