



**THE DATASHEET OF
BU90R104-E2**



LVDS Interface LSI

35bit LVDS Receiver 5:35 DeSerializer

BU90R104

•General Description

The BU90R104 receiver operates from 8MHz to 112MHz wide clock range.

The BU90R104 converts the LVDS serial data streams back into 35bits of LVCMOS parallel data.

Data is transmitted seven times (7X) stream and reduce the cable number by 3(1/3) or less.

I/O Voltage range is 2.3 to 3.6V, so it is available for many products.

•Features

- 5 channels of LVDS data stream are converted to 35bits data of parallel LVCMOS level outputs.
- 30bits of RGB output data, 5bits of timing and control output data(HSYNC, VSYNC, DE, CTL1 and CTL2) are transmitted available.
- Support clock frequency from 8MHz up to 112MHz.
- Support consumer video format including 480i, 480P, 720P and 1080i as well.
- Support many kinds of PC video formats such as VGA, SVGA, XGA and SXGA.
- Provide 784Mbps per 1ch or 3.92Gbps per device throughput rate using 112MHz clock rate.

•Key Specifications

- Supply Voltage Range 2.30 to 3.60 V
- Operating Frequency 8 to 112 MHz
- Operating Temperature Range -40 to +85 °C

•Packages

- TQFP64V 12.0mm×12.0mm×1.0mm

•Applications

- Flat panel display
- Security camera, Digital camera
- Tablet
- User programmable LVCMOS data output triggering timing by using either rising or falling edge of clock.
- 30bit LVDS transmitter is recommended to use BU8254KVT.

•Block Diagram

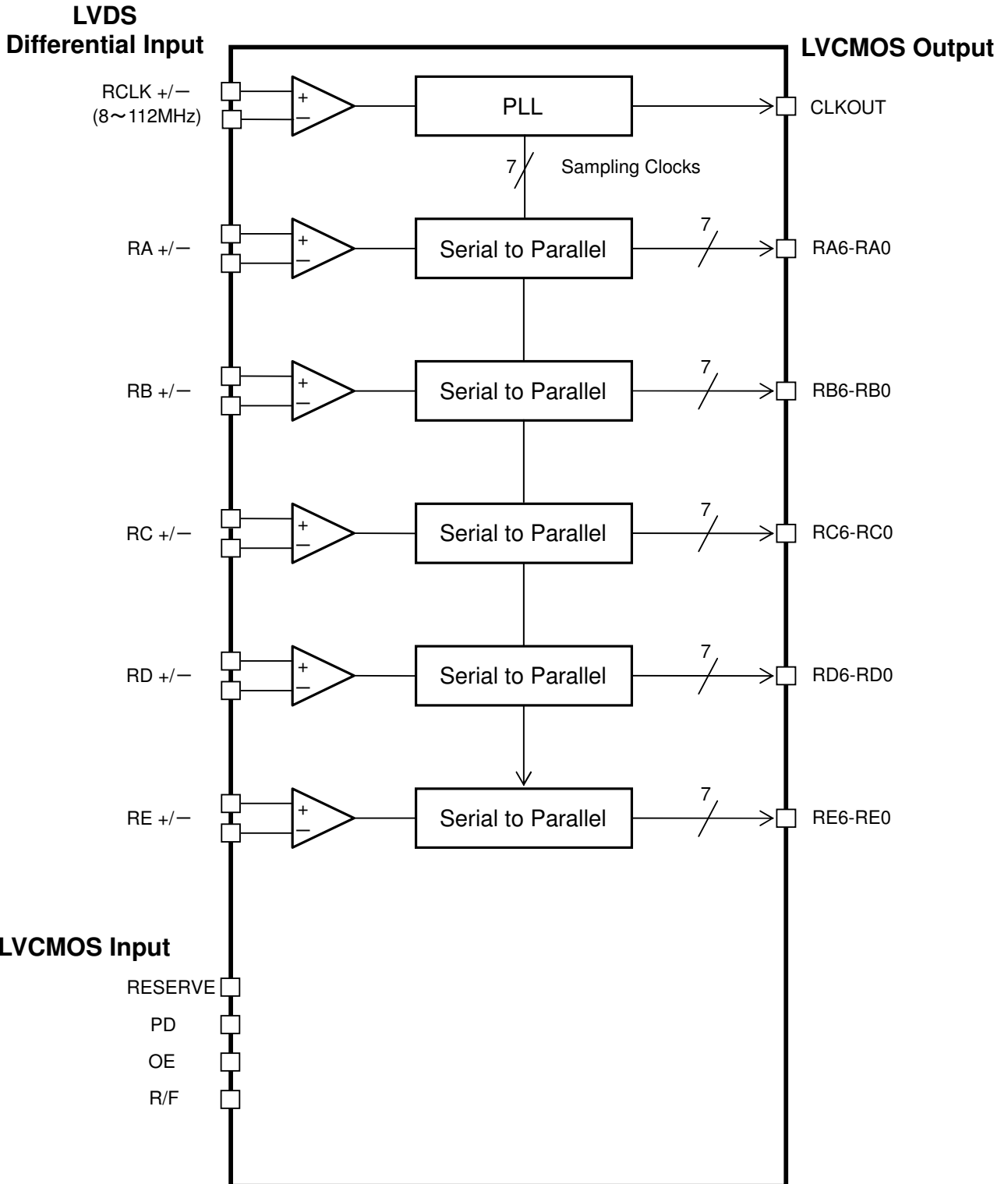

Figure 1. Block Diagram

●Pin Configuration

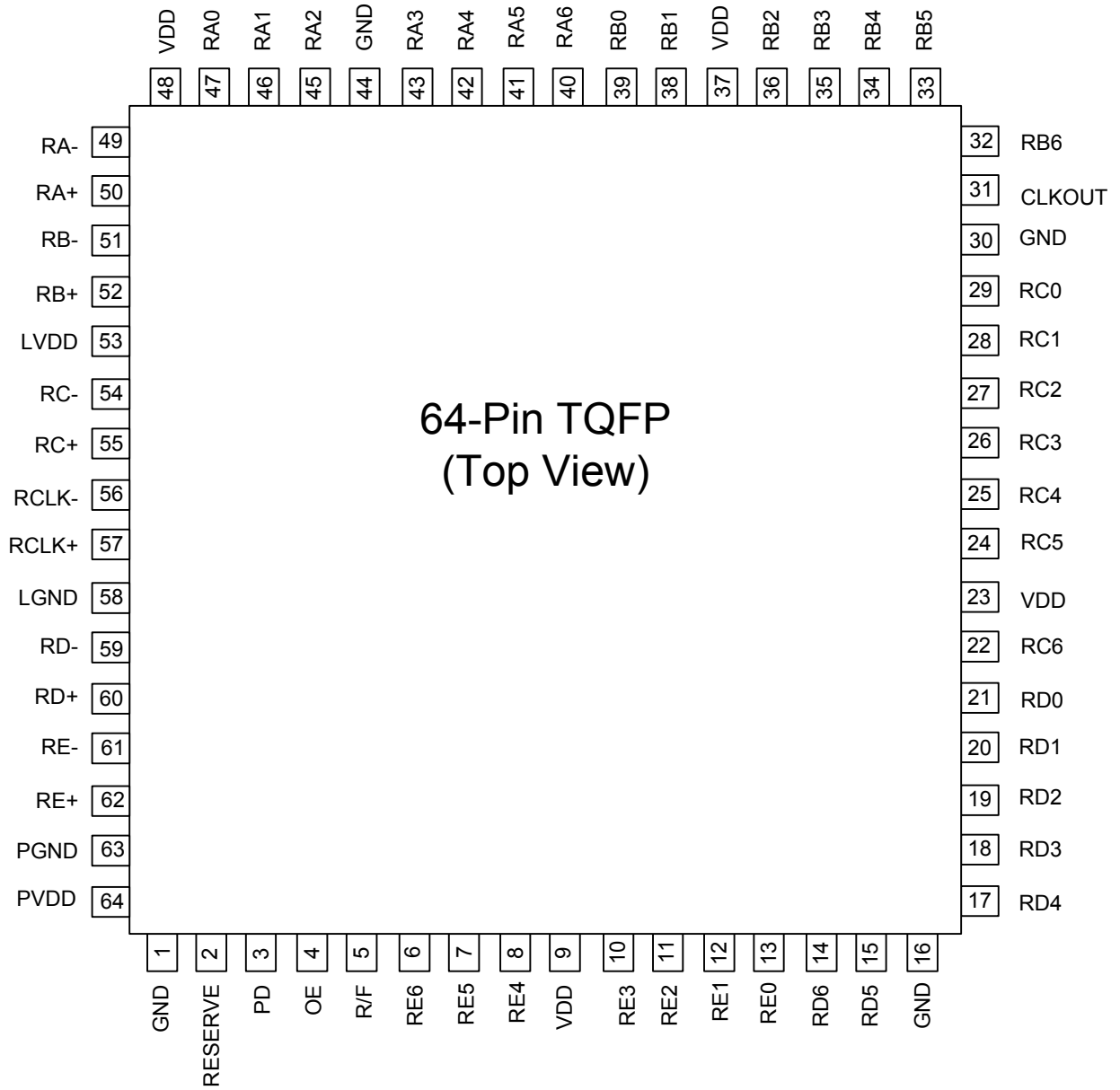

Figure 2. Pin Configuration (Top View)

●Pin Description

Pin Name	Pin No.	I/O	Description
RA+, RA-	50,49	LVDS Input	LVDS data input + : Positive input of LVDS data differential pair. - : Negative input of LVDS data differential pair.
RB+, RB-	52,51	LVDS Input	
RC+, RC-	55,54	LVDS Input	
RD+, RD-	60,59	LVDS Input	
RE+, RE-	62,61	LVDS Input	
RCLK+, RCLK-	57,56	LVDS Input	LVDS clock Input
RA6~RA0	40,41,42,43, 45,46,47	Output	LVCMOS data outputs.
RB6~RB0	32,33,34,35, 36,38,39	Output	
RC6~RC0	22,24,25,26, 27,28,29	Output	
RD6~RD0	14,15,17,18, 19,20,21	Output	
RE6~RE0	6,7,8,10, 11,12,13	Output	
RESERVE	2	Input	Reserved input must be "Low" for normal operation.
PD	3	Input	Power down input for the internal system. H : Normal operation. L : Power down (All output are "Low").
OE	4	Input	Power down input for the data output driver. H : Output enable (Normal operation). L : Output disable (All outputs are "Hi-Z").
R/F	5	Input	Select input pin for data output clock triggering edge. H : Output data is latched on rising edge. L : Output data is latched on falling edge.
VDD	9,23,37,48	Power	3.3V output driver and digital core power supply pin.
CLKOUT	31	Output	LVCMOS level clock output.
GND	1,16,30,44	Ground	Ground pin for both data output driver cells and the digital cores.
LVDD	53	Power	Power supply pin for LVDS core.
LGND	58	Ground	Ground pin for LVDS core.
PVDD	64	Power	Power supply pin for PLL core.
PGND	63	Ground	Ground pin for PLL core.

●Function Description

PD	R/F	OE	Data output (Rxn) <small>(Note1)</small>	Clock output
0	0	0	Hi-Z	Hi-Z
0	0	1	All fixed low	Fixed Low
0	1	0	Hi-Z	Hi-Z
0	1	1	All fixed low	Fixed Low
1	0	0	Hi-Z	Hi-Z
1	0	1	Data output	Output data is latched by falling edge of clock.
1	1	0	Hi-Z	Hi-Z
1	1	1	Data output	Output data is latched by rising edge of clock

(Note1): Rxn

x = A,B,C,D,E

n = 0,1,2,3,4,5,6

●Absolute Maximum Ratings

Parameter	Symbol	Ratings		Unit
		Min	Max	
Supply voltage	V_{DD}	-0.3	+4.0	V
Input voltage	V_{IN}	-0.3	$V_{DD}+0.3$	V
Output voltage	V_{OUT}	-0.3	$V_{DD}+0.3$	V
Storage temperature range	Tstg	-55	+125	°C

●Package power

Package	PD(W)	DERATING(W/°C) ^(Note2)
TQFP64V	0.7	0.007
	1.0 ^(Note3)	0.01 ^(Note3)

(Note2)At temperature $T_a > 25^\circ\text{C}$

(Note3)Package power when mounting on the PCB board.

The size of PCB board :70 × 70 × 1.6(mm³)

The material of PCB board :The FR4 glass epoxy board.(3% or less copper foil area)

●Recommended Operating Conditions

Parameter	Symbol	Ratings			Unit	Condition
		Min	Typ	Max		
Supply voltage	V_{DD}	2.3	3.3	3.6	V	VDD, LVDD, PVDD
Supply Noise Voltage	V_{NOZ}	-	-	0.1	V	
Operating temperature range	T_{opr}	-40	-	+85	°C	Clock frequency from 8MHz up to 90MHz
		0	-	+70	°C	Clock frequency from 90MHz up to 112MHz

•DC characteristics

Table 1. LVCMOS DC Specifications (VDD=2.3~3.6V, Ta=-40~+85°C)

Parameter	Symbol	Limits			Unit	Conditions
		Min	Typ	Max		
High Level Input Voltage	V _{IH}	V _{DD} × 0.8	-	V _{DD}	V	
Low Level Input Voltage	V _{IL}	0.0	-	V _{DD} × 0.2	V	
High Level Output Voltage	V _{OH}	V _{DD} -0.5	-	V _{DD}	V	I _{OH} =-4mA (data) I _{OH} =-8mA (clock)
Low Level Output Voltage	V _{OL}	0.0	-	0.4	V	I _{OL} =4mA (data) I _{OL} =8mA (clock)
Input Current	I _{INC}	-	-	± 10	μA	0V ≤ V _{IN} ≤ V _{DD}

Table 2. LVDS Receiver DC Specifications (VDD=2.3~3.6V, Ta=-40~+85°C)

Parameter	Symbol	Limits			Unit	Conditions
		Min	Typ	Max		
Differential Input High threshold	V _{TH}	-	-	100	mV	V _{OC} =1.2V
Differential Input Low threshold	V _{TL}	-100	-	-	mV	V _{OC} =1.2V
Input Current	I _{INL}	-	-	± 25	μA	V _{IN} =2.4V / 0V V _{DD} =3.6V
Common mode Voltage	V _{OC}	0.8	1.2	1.6	V	V _{ID} =200mV
Differential Input Voltage	V _{ID}	100	-	600	mV	-

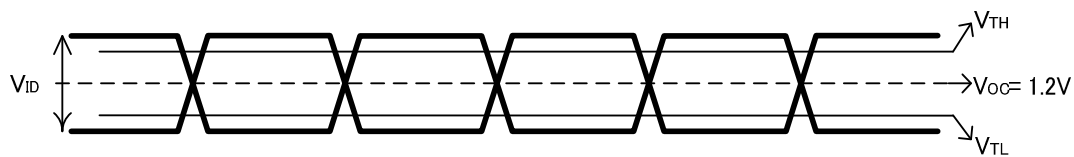

Figure 3. LVDS Receiver DC Specifications

•Supply Current

Parameter	Symbol	Limits		Unit	Conditions	
		Typ	Max			
Receiver supply current (Gray Scale Pattern)	I_{RCCG}	52	-	mA	$f_{CLKOUT}=90MHz$	$C_L=8pF, V_{DD}=3.3V$
Receiver supply current (Worst Case Pattern)	I_{RCCW}	95	-	mA	$f_{CLKOUT}=90MHz$	$C_L=8pF, V_{DD}=3.3V$
Receiver power down supply current	I_{RCCS}	-	10	μA	PD=L, OE=L	

Gray Scale Pattern

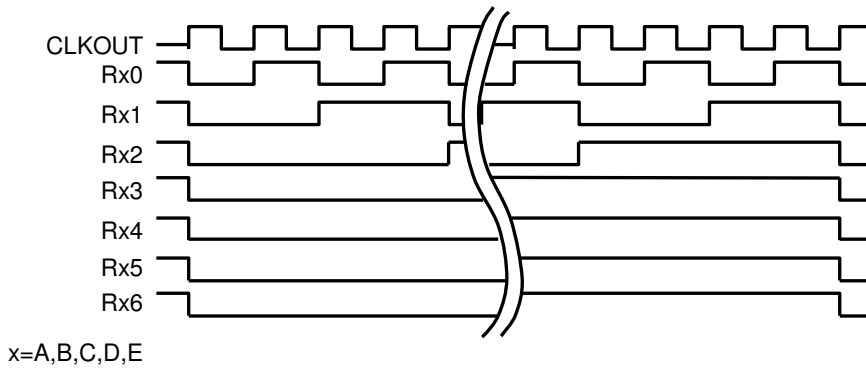

Figure 4. Gray Scale Pattern

Worst Case Pattern (Maximum power condition)

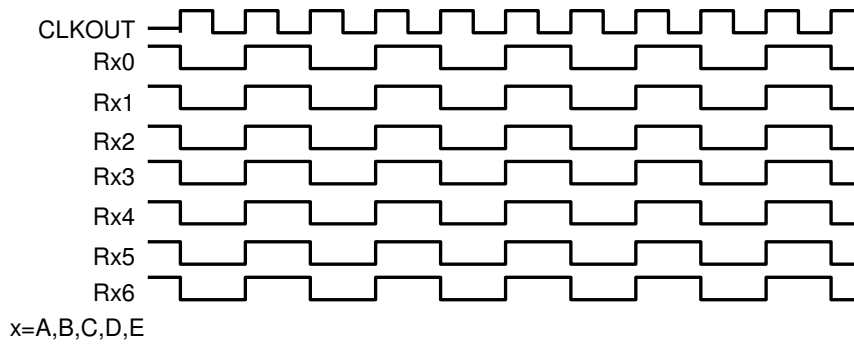

Figure 5. Worst Case Pattern

●AC characteristics

Table 3. Switching Characteristics (VDD=2.3~3.6V, Ta=-40~85°C)

Parameter	Symbol	Limits			Unit
		Min	Typ	Max	
CLKOUT Period	t _{RCP}	8.93	-	125	ns
CLKOUT "H" Time	t _{RCH}	-	0.5t _{RCP} -1.0	-	ns
CLKOUT "L" Time	t _{RCL}	-	0.5t _{RCP} -1.0	-	ns
LVC MOS Data Setup to CLKOUT	t _{RS}	0.5t _{RCP} -1.4	-	-	ns
LVC MOS Data Hold from CLKOUT	t _{RH}	0.23t _{RCP} -1.0	-	-	ns
LVC MOS Data Rise time	t _{TLH}	-	1.0	2.0	ns
LVC MOS Data Fall time	t _{THL}	-	1.0	2.0	ns
Input Data Position 0	t _{RIP1}	-0.25	0.0	+0.25	ns
Input Data Position 1	t _{RIP0}	$\frac{t_{RCIP}}{7} - 0.25$	$\frac{t_{RCIP}}{7}$	$\frac{t_{RCIP}}{7} + 0.25$	ns
Input Data Position 2	t _{RIP6}	$2 \frac{t_{RCIP}}{7} - 0.25$	$2 \frac{t_{RCIP}}{7}$	$2 \frac{t_{RCIP}}{7} + 0.25$	ns
Input Data Position 3	t _{RIP5}	$3 \frac{t_{RCIP}}{7} - 0.25$	$3 \frac{t_{RCIP}}{7}$	$3 \frac{t_{RCIP}}{7} + 0.25$	ns
Input Data Position 4	t _{RIP4}	$4 \frac{t_{RCIP}}{7} - 0.25$	$4 \frac{t_{RCIP}}{7}$	$4 \frac{t_{RCIP}}{7} + 0.25$	ns
Input Data Position 5	t _{RIP3}	$5 \frac{t_{RCIP}}{7} - 0.25$	$5 \frac{t_{RCIP}}{7}$	$5 \frac{t_{RCIP}}{7} + 0.25$	ns
Input Data Position 6	t _{RIP2}	$6 \frac{t_{RCIP}}{7} - 0.25$	$6 \frac{t_{RCIP}}{7}$	$6 \frac{t_{RCIP}}{7} + 0.25$	ns
Phase Locked Loop Set Time	t _{RPLL}	-	-	10.0	ms
Clock Input Period	t _{RCIP}	8.93	-	125	ns

●AC Timing

■LVCMOS

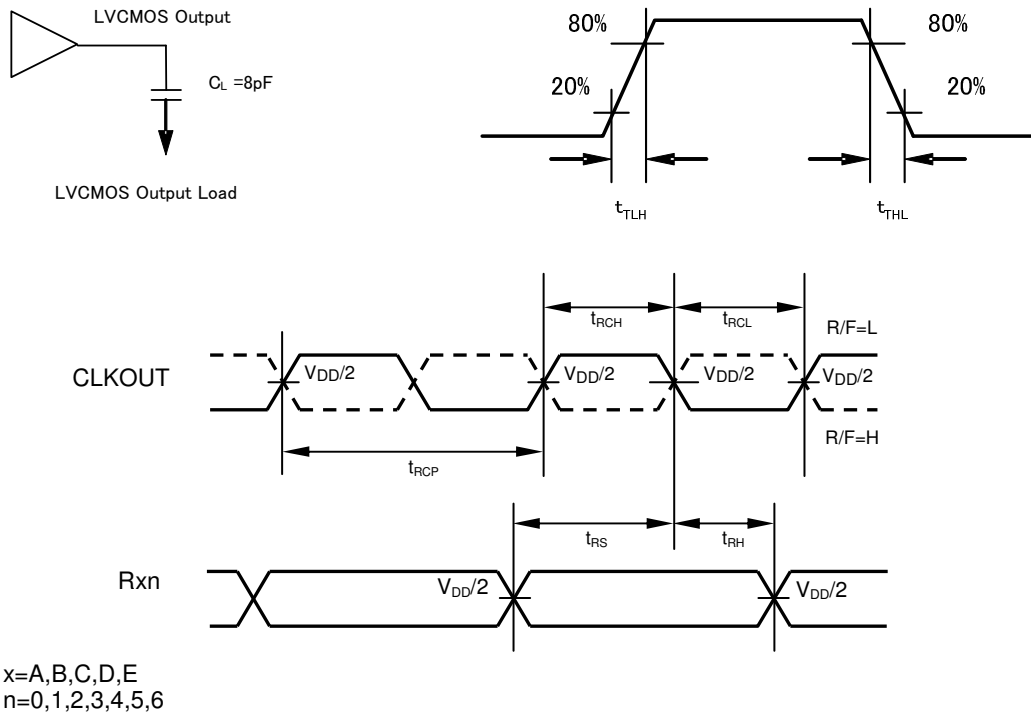

Figure 6. LVCMOS Output Timing

■Phase-Locked Loop Set Time

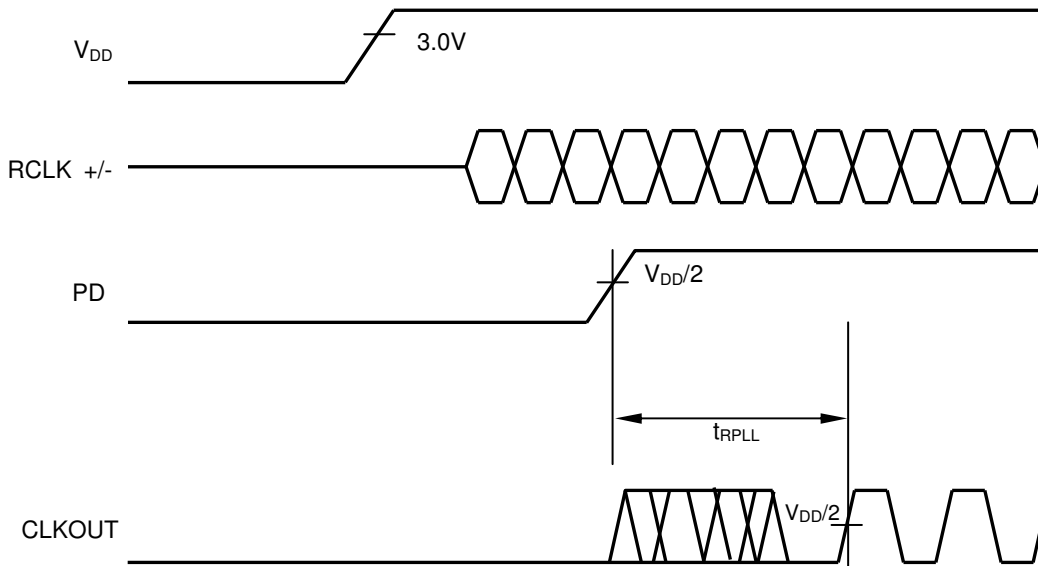

Figure 7. Phase-Locked Loop Set Time

•LVDS Data ,Clock Input Timing

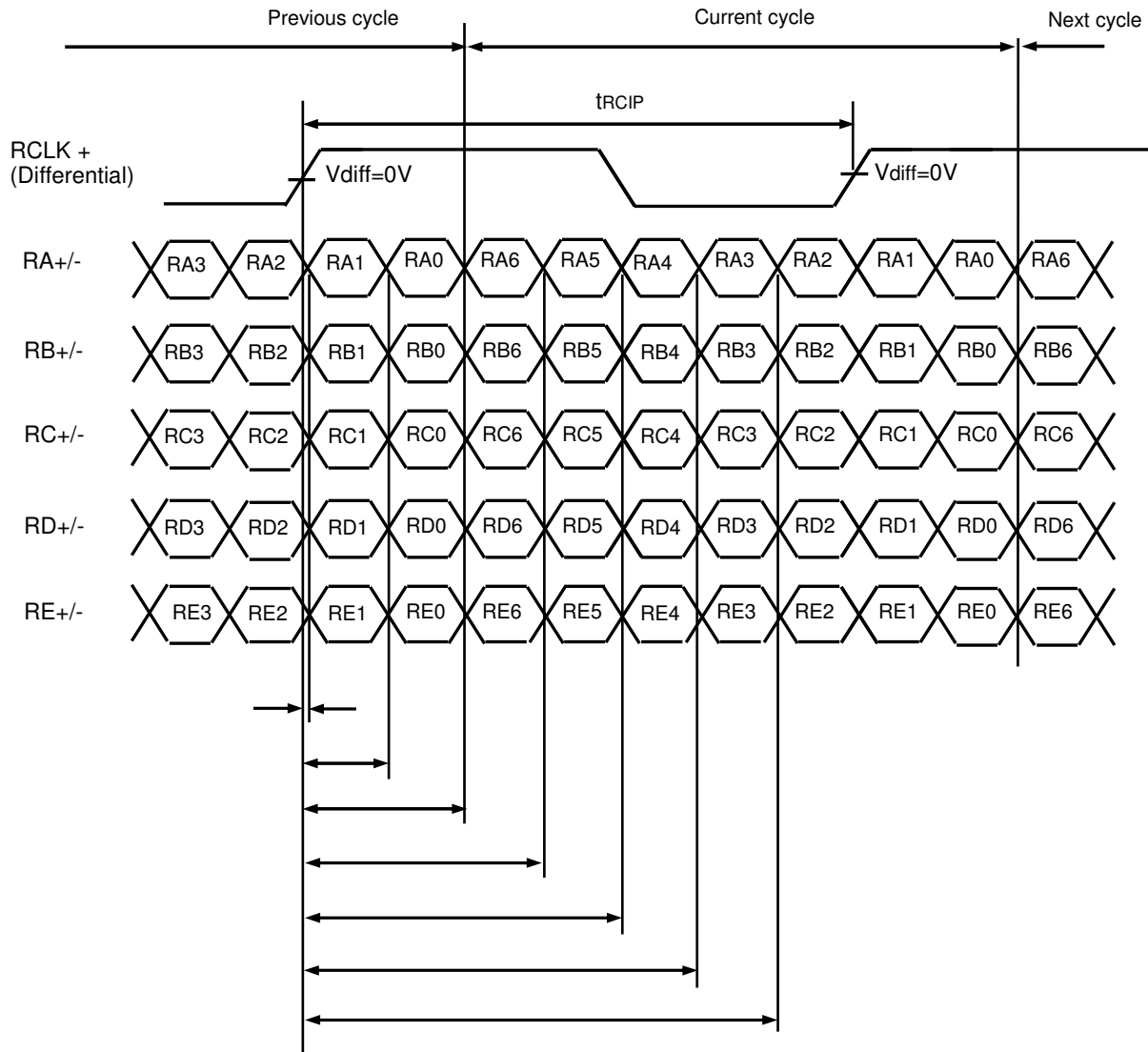

Figure 8. LVDS Data ,Clock Input Timing

•LVDS Data, Clock Input and LVCMOS Output Timing

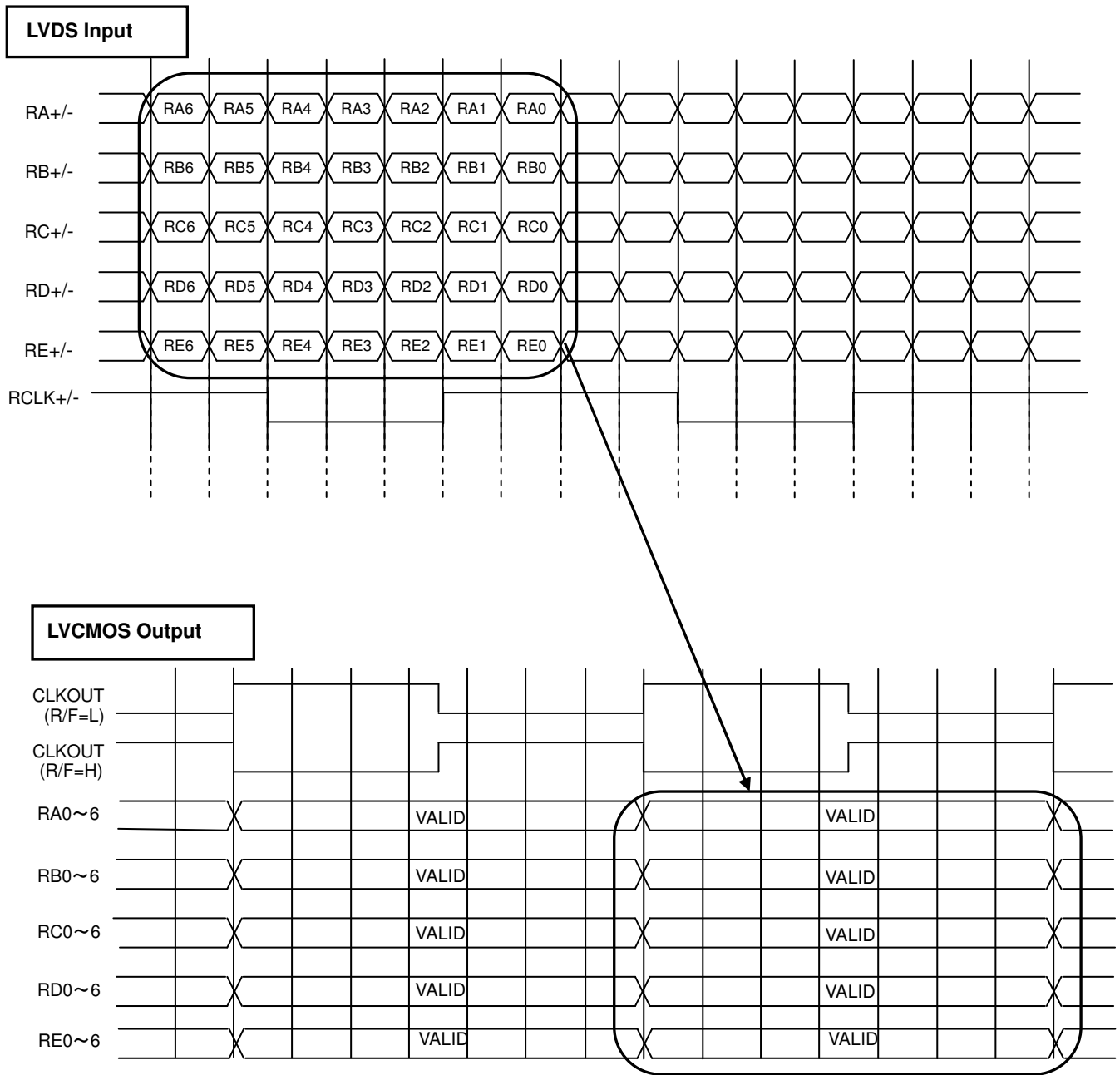

Figure 9. LVDS Data, Clock Input and LVCMOS Output Timing

●About the Power On Reset

Power on reset is not mandatory for this device.
 (The PD pin should be set to high level when power on reset procedure is not used.)

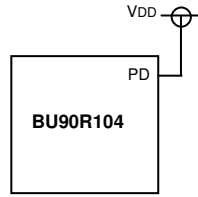
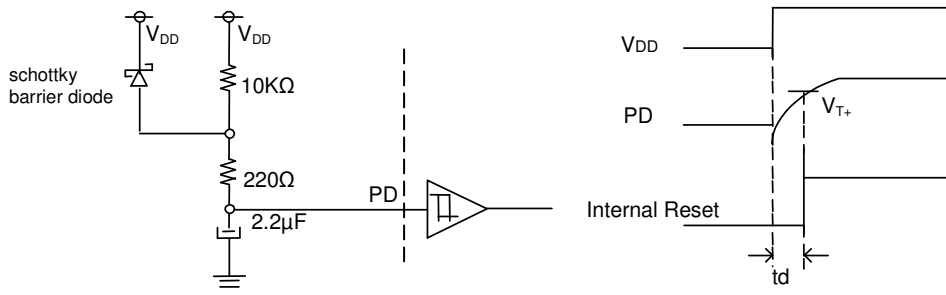

Figure 10. Terminal connection when power on reset is not used.

However, Power on reset procedure is strongly recommend for internal logic initialization by following two methods.

- ①The method of using CR circuit.
- ②The method of using external specific IC.

It is recommend to do enough examination for target application.



Be careful of temperature of the capacitor especially over and again.
 B characteristic ceramics and function polymer aluminum electrolysis are recommended.

t_d is approximately equal to 20ms when the left RC coils are applied.

Figure 11. Power on reset by external a CR circuit

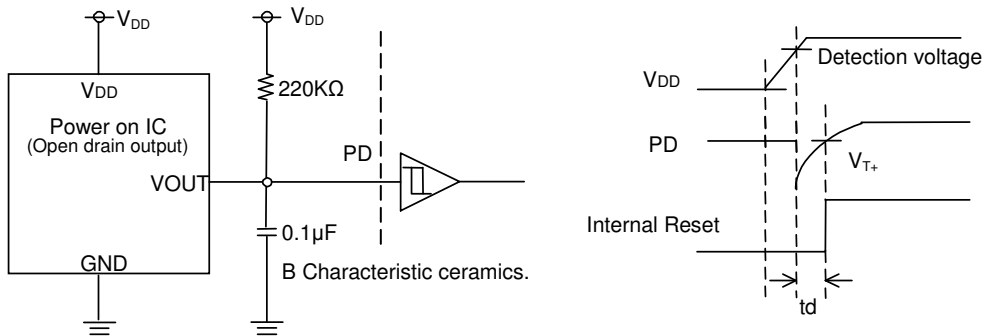
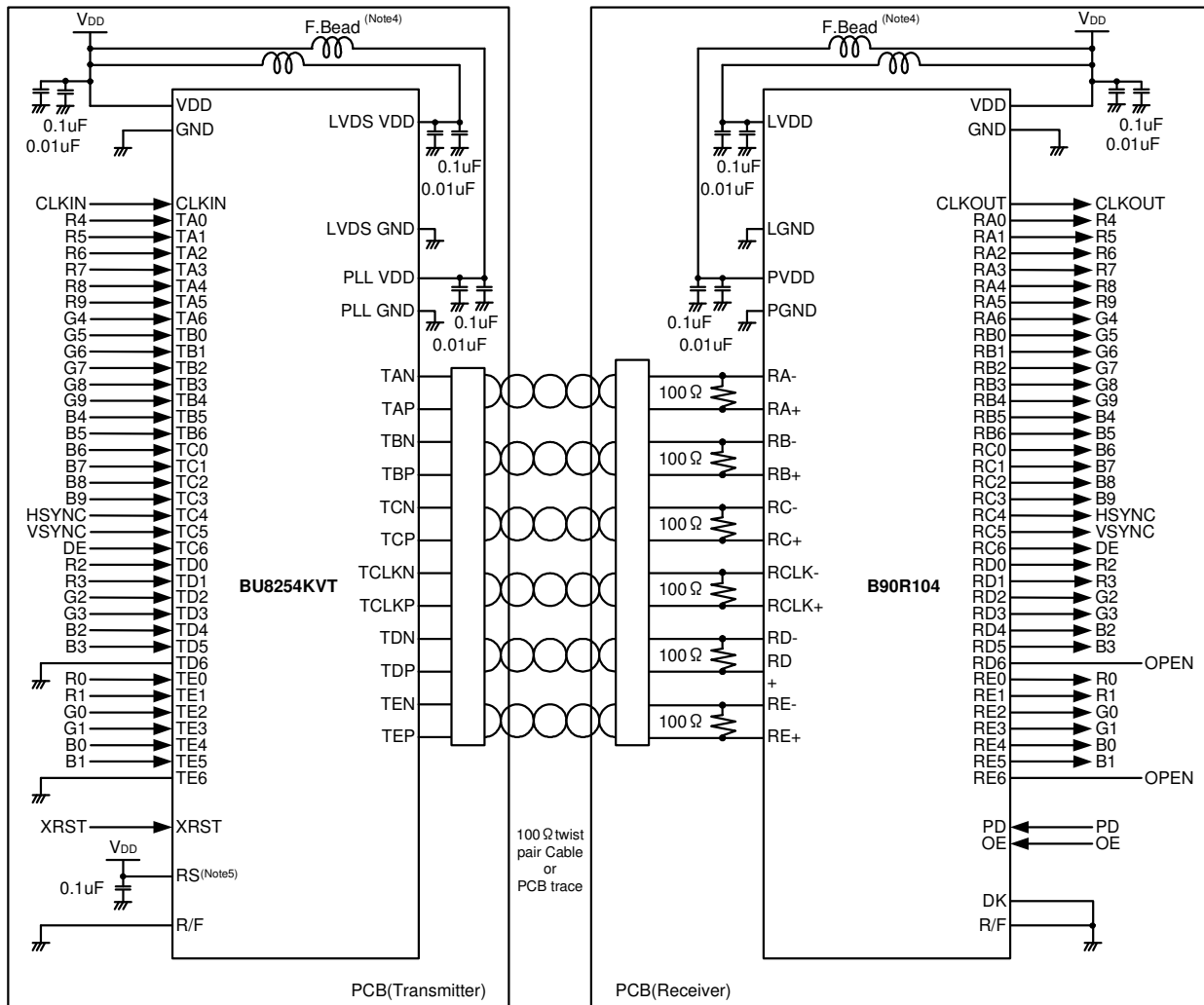

Figure 12. Power on reset by specific IC

●Application Circuit (10bit LVCMOS Level Input & LVCMOS Level Output)

Example:

- BU8254KVT : LVCMOS level input/Falling edge/LVDS normal(350mV) swing output
- BU90R104 : LVCMOS level output/Falling edge



(Note4) Recommended Parts:
 F.Bead : BLM18A-Series (Murata Manufacturing Co.)
 (Note5) If RS pin is tied to V_{DD}, LVDS swing is 350 mV.
 If RS pin is tied to GND, LVDS swing is 200 mV.

Figure 13. Application Circuit (10bit LVCMOS Level Input & LVCMOS Level Output)

●About the no used differential inputs
 If there are no used differential inputs, be sure to set them into GND level.
 The outputs are fixed High level, when differential inputs set GND.

●Application Circuit (10bit Small Swing Input & LVCMOS Level Output)

Example:

- BU8254KVT : LVCMOS level input/Falling edge/LVDS normal(350mV) swing output
- BU90R104 : LVCMOS level output/Falling edge

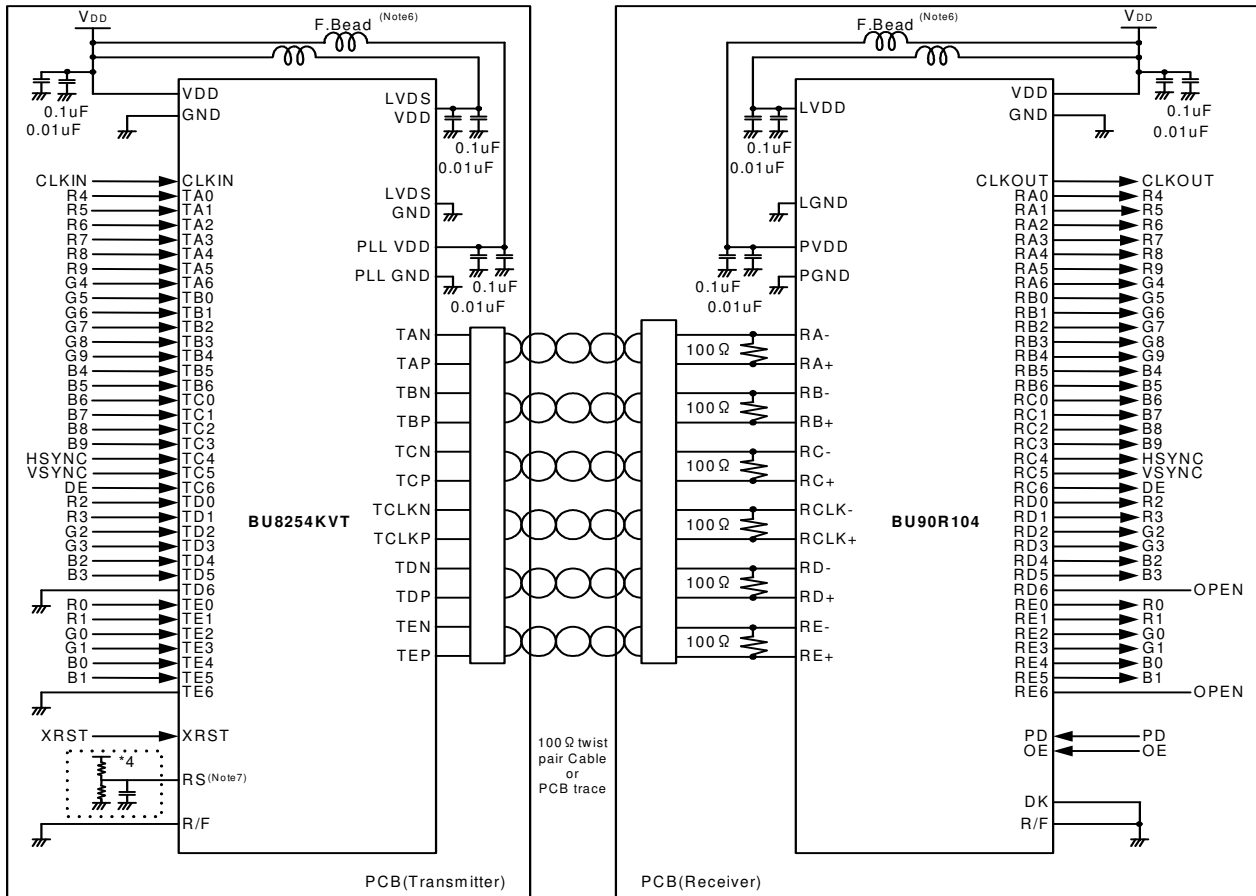

(Note6) Recommended Parts:

F.Bead : BLM18A-Series (Murata Manufacturing Co.)

(Note7) RS pin acts as VREF input pin when input voltage is set to half of high level signal input. We recommend to locate by-pass condenser near the RS pin.

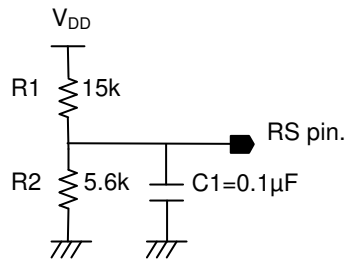

Example for LVTTTL(1.8V input):(R1,R2)=(15kΩ,5.6kΩ)

Figure 14. Application Circuit (10bit Small Swing Input & LVCMOS Level Output)

●Status of this document

The Japanese version of this document is formal specification. A customer may use this translation version only for a reference to help reading the formal version.

If there are any differences in translation version of this document formal version takes priority

●Notes for use

- 1) This chip is not designed to protect from radioactivity.
- 2) The chip is made strictly for the specific application or equipment.
Then it is necessary that the unit is measured as need.
- 3) This document may be used as strategic technical data which subjects to COCOM regulations.

Physical Dimension, Tape and Reel Information

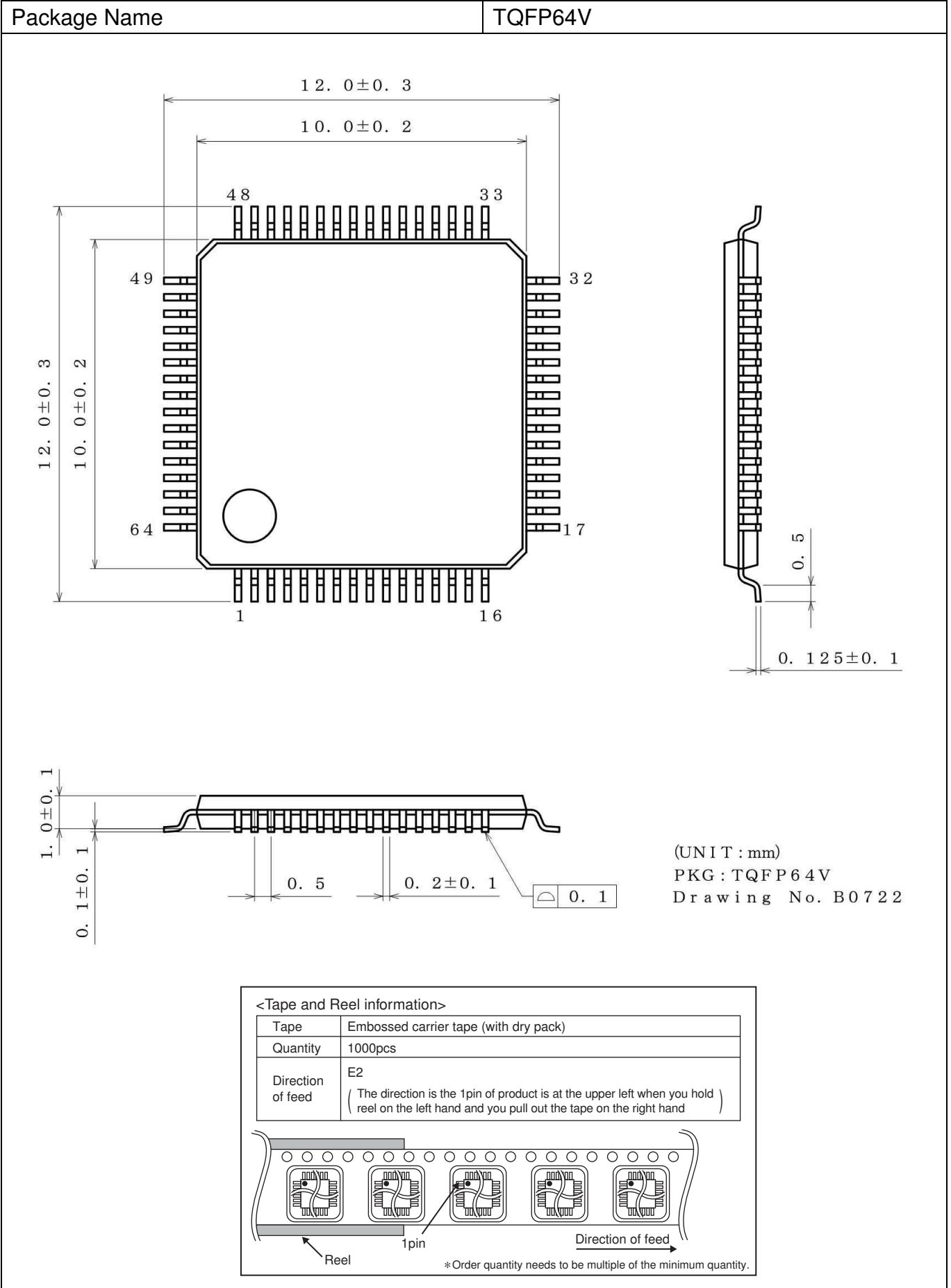

Notice

Precaution on using ROHM Products

- Our Products are designed and manufactured for application in ordinary electronic equipments (such as AV equipment, OA equipment, telecommunication equipment, home electronic appliances, amusement equipment, etc.). If you intend to use our Products in devices requiring extremely high reliability (such as medical equipment ^(Note 1), transport equipment, traffic equipment, aircraft/spacecraft, nuclear power controllers, fuel controllers, car equipment including car accessories, safety devices, etc.) and whose malfunction or failure may cause loss of human life, bodily injury or serious damage to property ("Specific Applications"), please consult with the ROHM sales representative in advance. Unless otherwise agreed in writing by ROHM in advance, ROHM shall not be in any way responsible or liable for any damages, expenses or losses incurred by you or third parties arising from the use of any ROHM's Products for Specific Applications.

(Note1) Medical Equipment Classification of the Specific Applications

JAPAN	USA	EU	CHINA
CLASS III	CLASS III	CLASS II b	CLASS III
CLASS IV		CLASS III	

- ROHM designs and manufactures its Products subject to strict quality control system. However, semiconductor products can fail or malfunction at a certain rate. Please be sure to implement, at your own responsibilities, adequate safety measures including but not limited to fail-safe design against the physical injury, damage to any property, which a failure or malfunction of our Products may cause. The following are examples of safety measures:
 - Installation of protection circuits or other protective devices to improve system safety
 - Installation of redundant circuits to reduce the impact of single or multiple circuit failure
- Our Products are designed and manufactured for use under standard conditions and not under any special or extraordinary environments or conditions, as exemplified below. Accordingly, ROHM shall not be in any way responsible or liable for any damages, expenses or losses arising from the use of any ROHM's Products under any special or extraordinary environments or conditions. If you intend to use our Products under any special or extraordinary environments or conditions (as exemplified below), your independent verification and confirmation of product performance, reliability, etc. prior to use, must be necessary:
 - Use of our Products in any types of liquid, including water, oils, chemicals, and organic solvents
 - Use of our Products outdoors or in places where the Products are exposed to direct sunlight or dust
 - Use of our Products in places where the Products are exposed to sea wind or corrosive gases, including Cl₂, H₂S, NH₃, SO₂, and NO₂
 - Use of our Products in places where the Products are exposed to static electricity or electromagnetic waves
 - Use of our Products in proximity to heat-producing components, plastic cords, or other flammable items
 - Sealing or coating our Products with resin or other coating materials
 - Use of our Products without cleaning residue of flux (even if you use no-clean type fluxes, cleaning residue of flux is recommended); or Washing our Products by using water or water-soluble cleaning agents for cleaning residue after soldering
 - Use of the Products in places subject to dew condensation
- The Products are not subject to radiation-proof design.
- Please verify and confirm characteristics of the final or mounted products in using the Products.
- In particular, if a transient load (a large amount of load applied in a short period of time, such as pulse. is applied, confirmation of performance characteristics after on-board mounting is strongly recommended. Avoid applying power exceeding normal rated power; exceeding the power rating under steady-state loading condition may negatively affect product performance and reliability.
- De-rate Power Dissipation (Pd) depending on Ambient temperature (Ta). When used in sealed area, confirm the actual ambient temperature.
- Confirm that operation temperature is within the specified range described in the product specification.
- ROHM shall not be in any way responsible or liable for failure induced under deviant condition from what is defined in this document.

Precaution for Mounting / Circuit board design

- When a highly active halogenous (chlorine, bromine, etc.) flux is used, the residue of flux may negatively affect product performance and reliability.
- In principle, the reflow soldering method must be used on a surface-mount products, the flow soldering method must be used on a through hole mount products. If the flow soldering method is preferred on a surface-mount products, please consult with the ROHM representative in advance.

For details, please refer to ROHM Mounting specification

Precautions Regarding Application Examples and External Circuits

1. If change is made to the constant of an external circuit, please allow a sufficient margin considering variations of the characteristics of the Products and external components, including transient characteristics, as well as static characteristics.
2. You agree that application notes, reference designs, and associated data and information contained in this document are presented only as guidance for Products use. Therefore, in case you use such information, you are solely responsible for it and you must exercise your own independent verification and judgment in the use of such information contained in this document. ROHM shall not be in any way responsible or liable for any damages, expenses or losses incurred by you or third parties arising from the use of such information.

Precaution for Electrostatic

This Product is electrostatic sensitive product, which may be damaged due to electrostatic discharge. Please take proper caution in your manufacturing process and storage so that voltage exceeding the Products maximum rating will not be applied to Products. Please take special care under dry condition (e.g. Grounding of human body / equipment / solder iron, isolation from charged objects, setting of Ionizer, friction prevention and temperature / humidity control).

Precaution for Storage / Transportation

1. Product performance and soldered connections may deteriorate if the Products are stored in the places where:
 - [a] the Products are exposed to sea winds or corrosive gases, including Cl₂, H₂S, NH₃, SO₂, and NO₂
 - [b] the temperature or humidity exceeds those recommended by ROHM
 - [c] the Products are exposed to direct sunshine or condensation
 - [d] the Products are exposed to high Electrostatic
2. Even under ROHM recommended storage condition, solderability of products out of recommended storage time period may be degraded. It is strongly recommended to confirm solderability before using Products of which storage time is exceeding the recommended storage time period.
3. Store / transport cartons in the correct direction, which is indicated on a carton with a symbol. Otherwise bent leads may occur due to excessive stress applied when dropping of a carton.
4. Use Products within the specified time after opening a humidity barrier bag. Baking is required before using Products of which storage time is exceeding the recommended storage time period.

Precaution for Product Label

QR code printed on ROHM Products label is for ROHM's internal use only.

Precaution for Disposition

When disposing Products please dispose them properly using an authorized industry waste company.

Precaution for Foreign Exchange and Foreign Trade act

Since our Products might fall under controlled goods prescribed by the applicable foreign exchange and foreign trade act, please consult with ROHM representative in case of export.

Precaution Regarding Intellectual Property Rights

1. All information and data including but not limited to application example contained in this document is for reference only. ROHM does not warrant that foregoing information or data will not infringe any intellectual property rights or any other rights of any third party regarding such information or data. ROHM shall not be in any way responsible or liable for infringement of any intellectual property rights or other damages arising from use of such information or data.:
2. No license, expressly or implied, is granted hereby under any intellectual property rights or other rights of ROHM or any third parties with respect to the information contained in this document.

Other Precaution



1. This document may not be reprinted or reproduced, in whole or in part, without prior written consent of ROHM.
2. The Products may not be disassembled, converted, modified, reproduced or otherwise changed without prior written consent of ROHM.
3. In no event shall you use in any way whatsoever the Products and the related technical information contained in the Products or this document for any military purposes, including but not limited to, the development of mass-destruction weapons.
4. The proper names of companies or products described in this document are trademarks or registered trademarks of ROHM, its affiliated companies or third parties.

General Precaution

1. Before you use our Products, you are requested to carefully read this document and fully understand its contents. ROHM shall not be in any way responsible or liable for failure, malfunction or accident arising from the use of any ROHM's Products against warning, caution or note contained in this document.
2. All information contained in this document is current as of the issuing date and subject to change without any prior notice. Before purchasing or using ROHM's Products, please confirm the latest information with a ROHM sales representative.
3. The information contained in this document is provided on an "as is" basis and ROHM does not warrant that all information contained in this document is accurate and/or error-free. ROHM shall not be in any way responsible or liable for any damages, expenses or losses incurred by you or third parties resulting from inaccuracy or errors of or concerning such information.

Looking for pricing, stock, or lifecycle information?

Click below to explore more details on WIN SOURCE:

-  [View BU90R104-E2 on WIN SOURCE](#)
-  [Rohm Semiconductor](#) Information

Optimize Your Supply Chain with WIN SOURCE Solutions

-  Global Sourcing Solution
-  Obsolete Management
-  Cost Control Management
-  Shortage Management
-  Alternative Solution
-  Excess Inventory Management