



**THE DATASHEET OF
RT9731AZQW(2)**



Dual Channel Precision Adjustable Current Limited Power Switch

General Description

The RT9731A/B is a dual channel power distribution switch intended for applications where precision current limiting is required or heavy capacitive loads and short circuits are encountered. This device offers a programmable current limit threshold between 560mA and 2.8A (typ.) per channel via an external resistor. The power-switch's rising and falling times are controlled to minimize current surges during on/off transitions.

Each channel of the RT9731A/B limits the output current to a safe level by switching into constant-current mode whenever the output load exceeds the current limit threshold. The FLAG logic output of each channel independently asserts low during over current.

The RT9731A/B is available in a thin WDFN-10L 3x3 package.

Ordering Information

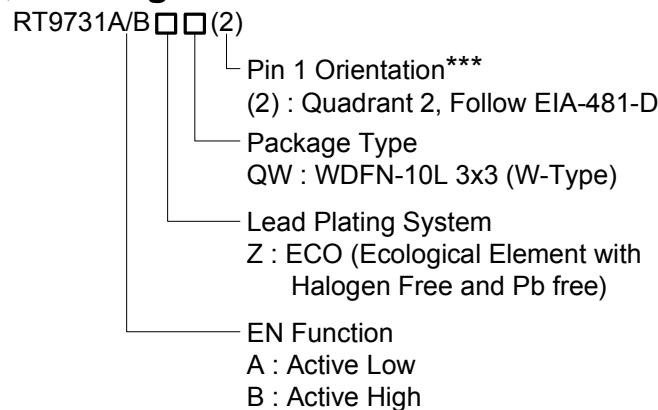

Note :

***Empty means Pin1 orientation is Quadrant 1

Richtek products are :

- ▶ RoHS compliant and compatible with the current requirements of IPC/JEDEC J-STD-020.
- ▶ Suitable for use in SnPb or Pb-free soldering processes.

Features

- 2.5V to 5.5V Input Voltage Range
- Two Separate Current Limiting Channels
- Meets USB Current Limiting Requirements
- Adjustable Current Limit from 560mA to 2.8A
- ±7.5% Current Limit Accuracy at 2.8A
- Two 44mΩ High Side MOSFETs
- 2μA Maximum Standby Supply Current
- Built-in Soft-Start
- Thin 10-Lead WDFN Package
- UL Approved—E219878 
- Nemko Approved-NO65969
- RoHS Compliant and Halogen Free

Applications

- USB Ports/Hubs
- Digital TV
- Set-Top Boxes
- VOIP Phones

Pin Configurations

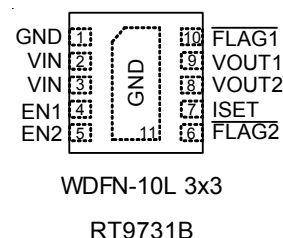
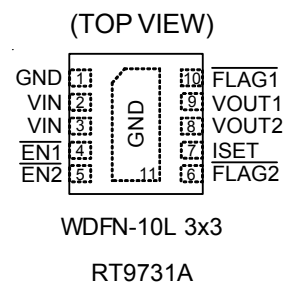

Marking Information

RT9731AZQW

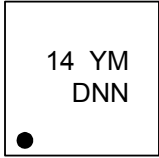

14 : Product Code
YMDNN : Date Code

RT9731BZQW

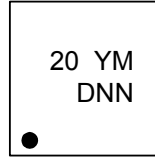

20 : Product Code
YMDNN : Date Code

Typical Application Circuit

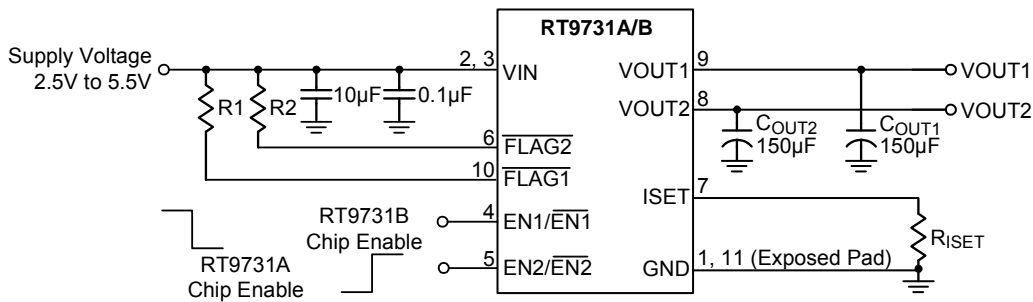

Note : R1, R2 ; Pull-Up Resistance (10k to 100k)

Functional Pin Description

Pin No.	Pin Name	Pin Function
1, 11 (Exposed Pad)	GND	Ground. The exposed pad must be soldered to a large PCB and connected to GND for maximum power dissipation.
2, 3	VIN	Input Voltage.
4	$\overline{\text{EN1}}$ (RT9731A)	Chip Enable (Active Low). Turns on power switch for channel 1.
	EN1 (RT9731B)	Chip Enable (Active High). Turns on power switch for channel 1.
5	$\overline{\text{EN2}}$ (RT9731A)	Chip Enable (Active Low). Turns on power switch for channel 2.
	EN2 (RT9731B)	Chip Enable (Active High). Turns on power switch for channel 2.
6	$\overline{\text{FLAG2}}$	Channel 2 Fault Indicator (Active Low). This open-drain output asserts low during over current and over temperature conditions.
7	ISET	Current Limit Set Pin. Connect to an external resistor to set the current limit threshold.
8	VOUT2	Channel 2 Power Switch Output.
9	VOUT1	Channel 1 Power Switch Output.
10	$\overline{\text{FLAG1}}$	Channel 1 Fault Indicator (Active Low). This open-drain output asserts low during over current and over temperature conditions.

Function Block Diagram

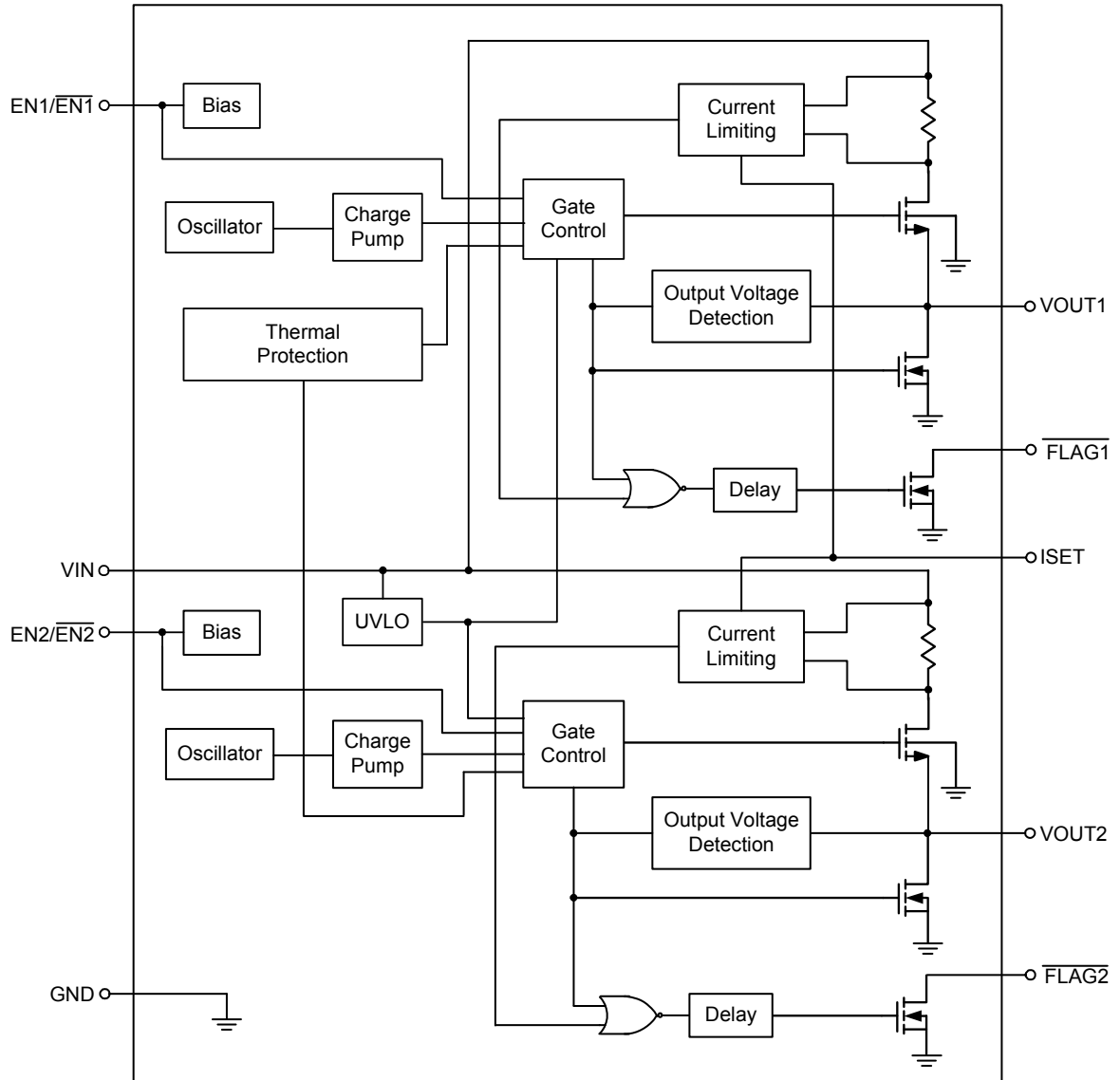

Absolute Maximum Ratings (Note 1)

- Supply Input Voltage, V_{IN} ----- -0.3V to 6V
- Output Voltage, V_{OUT1}, V_{OUT2} ----- -0.3V to 6V
- $\overline{EN1}, \overline{EN2}, \overline{EN1}, \overline{EN2}$ ----- -0.3V to 6V
- $\overline{FLAG1}, \overline{FLAG2}$ ----- 6V
- Power Dissipation, $P_D @ T_A = 25^\circ C$
WDFN-10L 3x3 ----- 1.429W
- Package Thermal Resistance (Note 2)
WDFN-10L 3x3, θ_{JA} ----- $70^\circ C/W$
WDFN-10L 3x3, θ_{JC} ----- $8.2^\circ C/W$
- Junction Temperature ----- $150^\circ C$
- Lead Temperature (Soldering, 10 sec.) ----- $260^\circ C$
- Storage Temperature Range ----- $-65^\circ C$ to $150^\circ C$
- ESD Susceptibility (Note 3)
HBM (Human Body Mode) ----- 2kV

Recommended Operating Conditions (Note 4)

- Supply Voltage, V_{IN} ----- 2.5V to 5.5V
- Chip Enable Voltage, EN ----- 0V to 5.5V
- Junction Temperature Range ----- $-40^\circ C$ to $100^\circ C$
- Ambient Temperature Range ----- $-40^\circ C$ to $85^\circ C$

Electrical Characteristics

($V_{IN} = 5V, T_A = 25^\circ C$, unless otherwise specified)

Parameter		Symbol	Test Conditions	Min	Typ	Max	Unit	
Resistor Limit Range		R_{ISET}		20	--	100	k Ω	
Switch On-Resistance		$R_{DS(ON)}$		--	44	50	m Ω	
Rising Time		t_R	$V_{IN} = 5.5V$	$C_{OUT} = 1\mu F,$ $R_{OUT} = 100\Omega$	2	3	4	ms
			$V_{IN} = 2.5V$		1	2	3	
Falling Time		t_F	$V_{IN} = 5.5V$	$C_{OUT} = 1\mu F,$ $R_{OUT} = 100\Omega$	--	0.8	--	ms
			$V_{IN} = 2.5V$		--	0.6	--	
ENx/ \overline{ENx} Input Threshold Voltage	Logic-High	V_{IH}	$V_{IN} = 2.5V$ to $5.5V$, Power On	1.1	--	--	V	
	Logic-Low	V_{IL}	$V_{IN} = 2.5V$ to $5.5V$, Shutdown	--	--	0.66		
ENx/ \overline{ENx} Threshold Hysteresis				--	55	--	mV	
ENx/ \overline{ENx} Input Current		$I_{ENx}/I_{\overline{ENx}}$	$V_{ENx}/V_{\overline{ENx}} = 0V$ to $5.5V$	0.5	--	0.5	μA	
Current Limit		I_{LIM}	$R_{ISET} = 20k\Omega$	2590	2800	3005	mA	
			$R_{ISET} = 61.9k\Omega$	--	900	--		
			$R_{ISET} = 100k\Omega$	--	560	--		
Supply Current		I_{SW_OFF}	Switch Off, $V_{OUT} = Open$	--	0.1	2	μA	
		I_{SW_ON}	Switch On, $V_{OUT} = Open$	$R_{ISET} = 20k\Omega$	--	130		200
$R_{ISET} = 100k\Omega$	--			100	150			
Reverse Leakage Current		I_{REV}	$V_{OUTx} = 5.5V, V_{IN} = 0V$	--	0.01	1	μA	

Parameter	Symbol	Test Conditions	Min	Typ	Max	Unit
Under Voltage Lockout Threshold	V_{UVLO}	VIN Rising	--	2.35	2.45	V
Under Voltage Lockout Hysteresis	ΔV_{UVLO}		--	35	--	mV
\overline{FLAGx} Output Low Voltage	$V_{\overline{FLAGx}}$	$I_{SINK} = 1mA$	--	--	180	mV
\overline{FLAGx} Off Current	$I_{\overline{FLAGx_OFF}}$	$V_{\overline{FLAGx}} = 5.5V$	--	--	1	μA
FLAG Delay Time	t_D	From fault condition to \overline{FLAGx} assertion	5	12	20	ms
Thermal Shutdown Protection	T_{SD}	$V_{OUTx} > 1V$	--	120	--	$^{\circ}C$
Thermal Shutdown Threshold in Short	T_{SD_SHT}	$V_{OUTx} < 1V$	--	100	--	$^{\circ}C$
Thermal Shutdown Hysteresis	ΔT_{SD}		--	20	--	$^{\circ}C$

Note 1. Stresses beyond those listed “Absolute Maximum Ratings” may cause permanent damage to the device. These are stress ratings only, and functional operation of the device at these or any other conditions beyond those indicated in the operational sections of the specifications is not implied. Exposure to absolute maximum rating conditions may affect device reliability.

Note 2. θ_{JA} is measured at $T_A = 25^{\circ}C$ on a high effective thermal conductivity four-layer test board per JEDEC 51-7. θ_{JC} is measured at the exposed pad of the package.

Note 3. Devices are ESD sensitive. Handling [precautions](#) are recommended.

Note 4. The device is not guaranteed to function outside its operating conditions.

Typical Operating Characteristics

Quiescent Current vs. Input Voltage

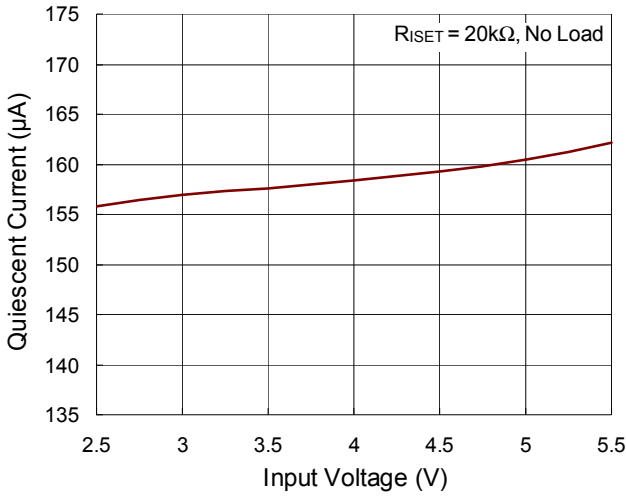

Quiescent Current vs. Temperature

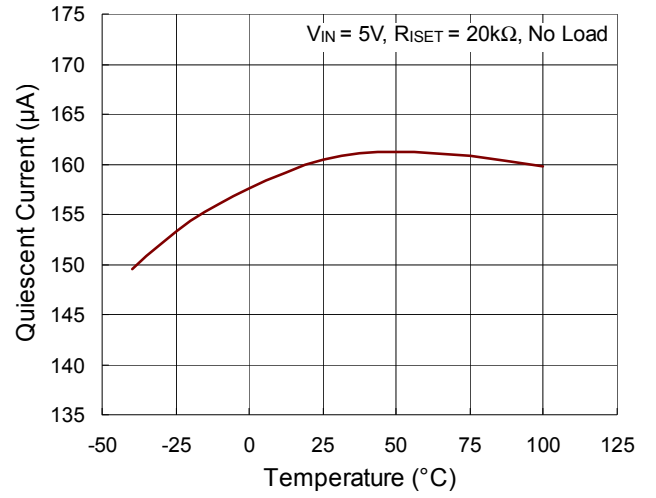

Shutdown Current vs. Input Voltage

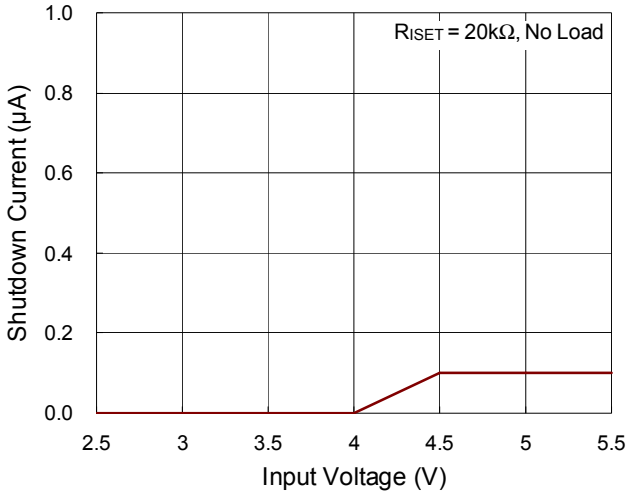

Shutdown Current vs. Temperature

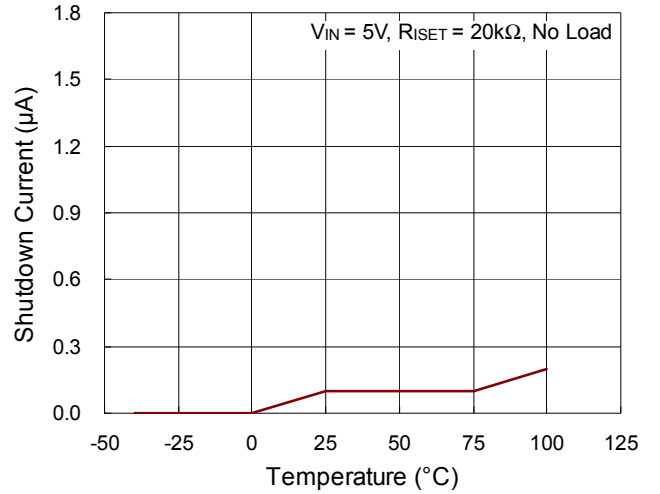

On Resistance vs. Input Voltage

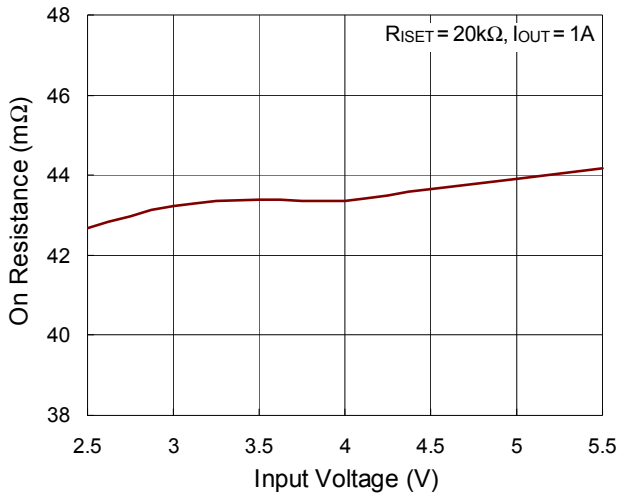

On Resistance vs. Temperature

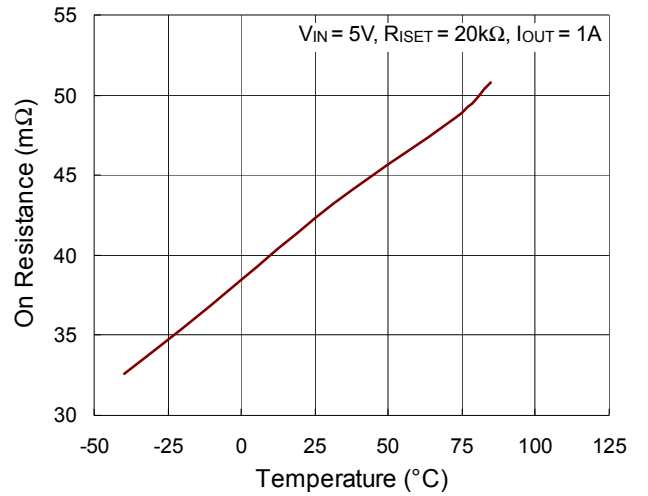

Output Voltage vs. Output Current

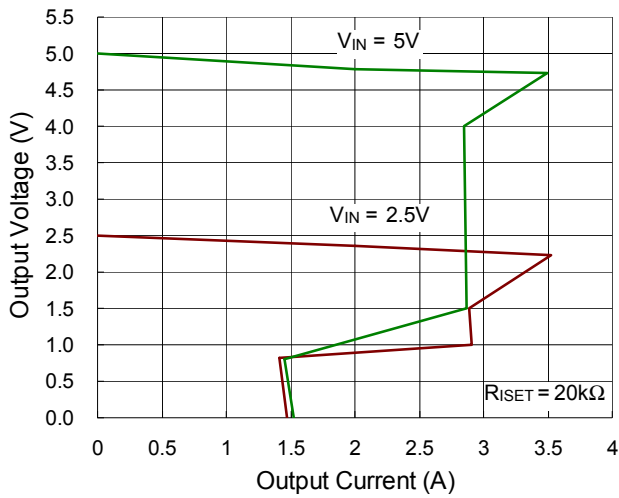

Current Limit vs. R_{ISET}

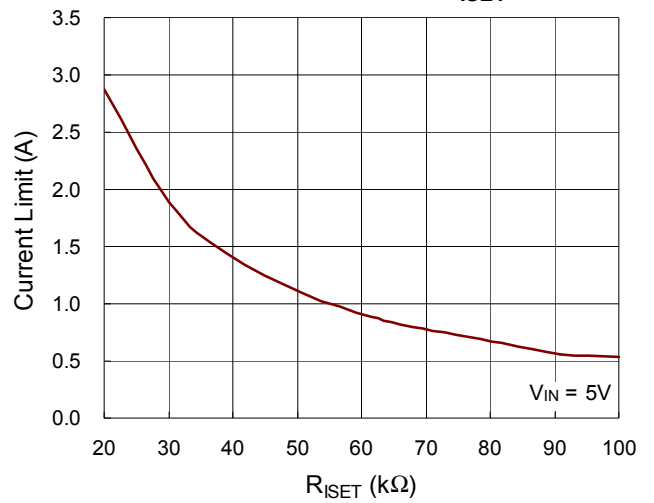

Current Limit vs. Input Voltage

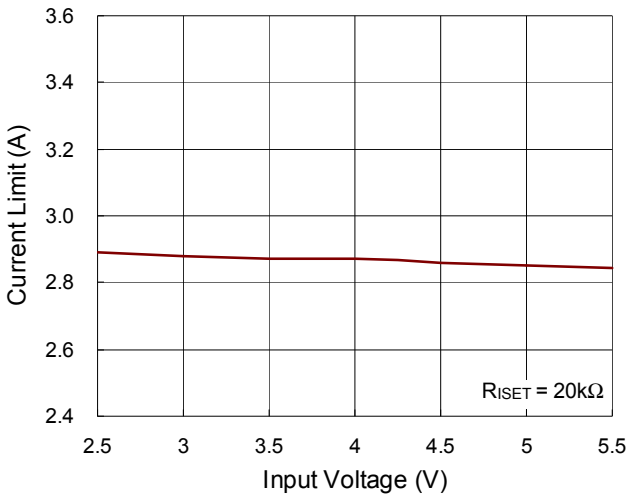

Current Limit vs. Temperature

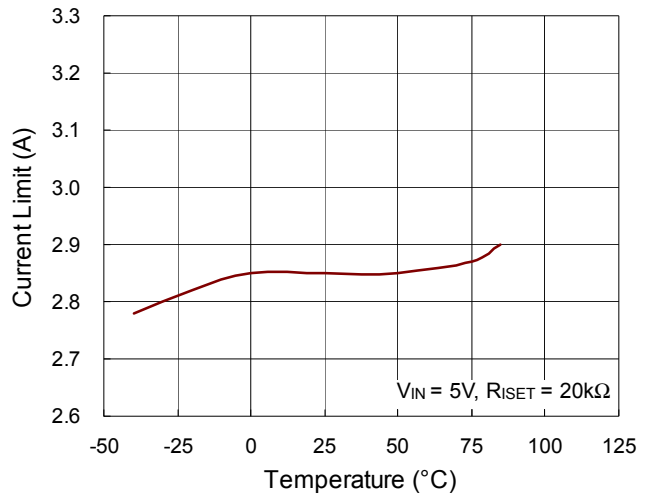

Short Current vs. Input Voltage

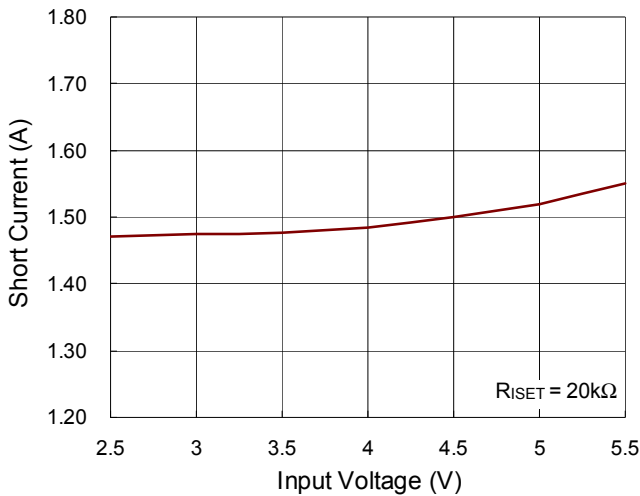

Short Current vs. Temperature

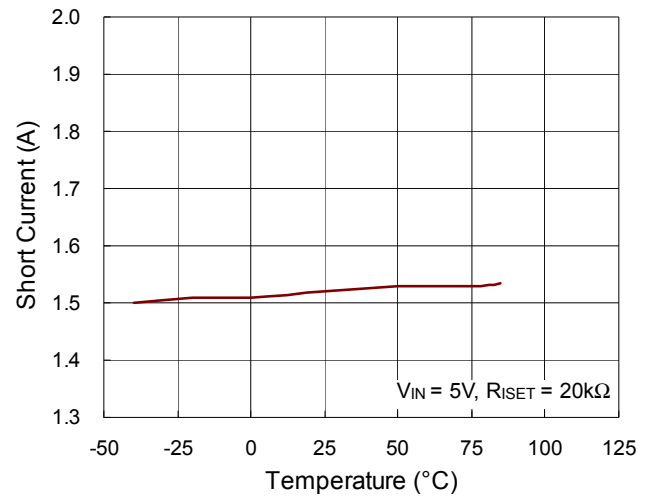

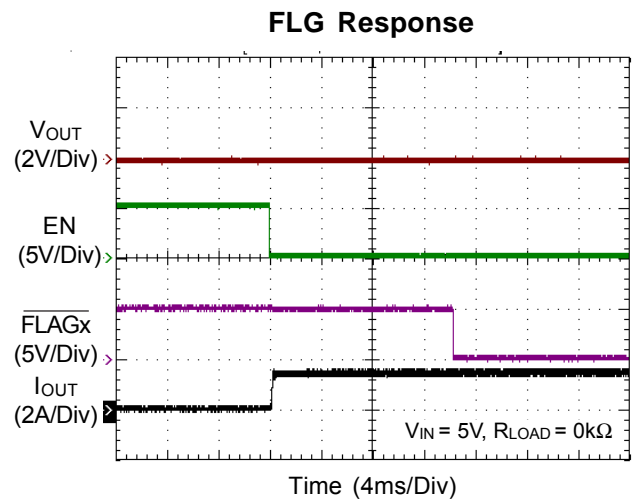
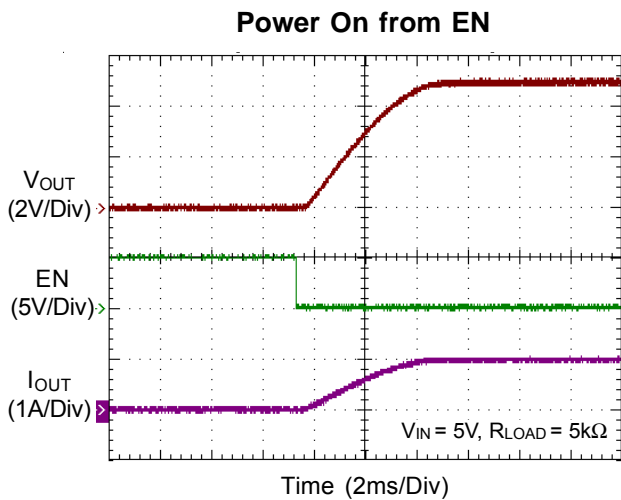
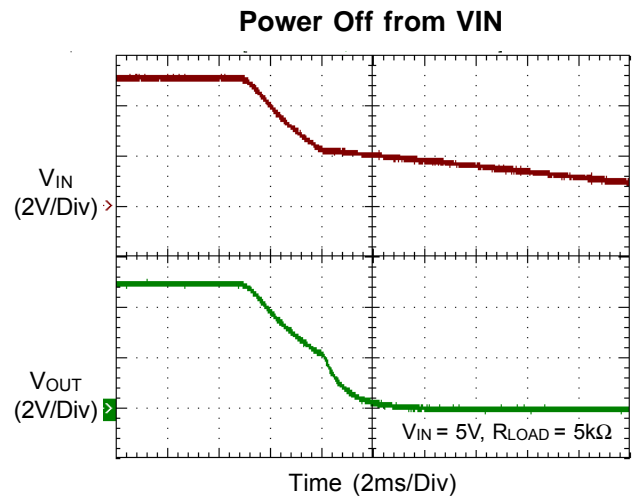
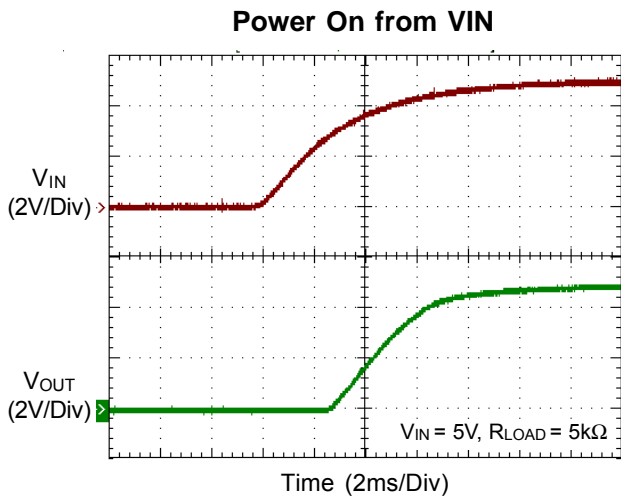
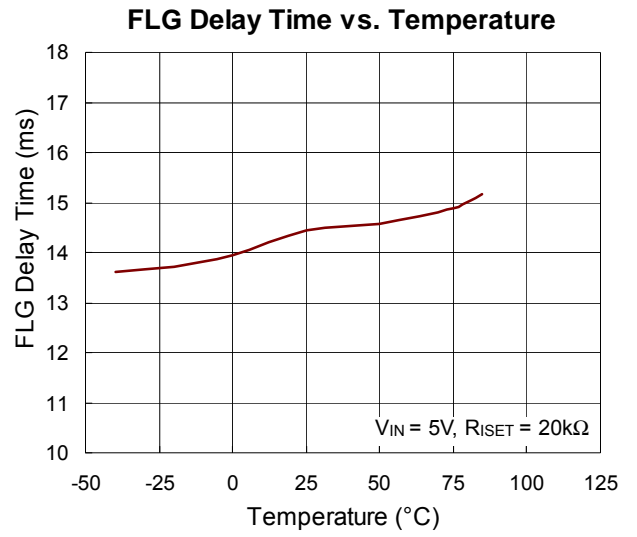
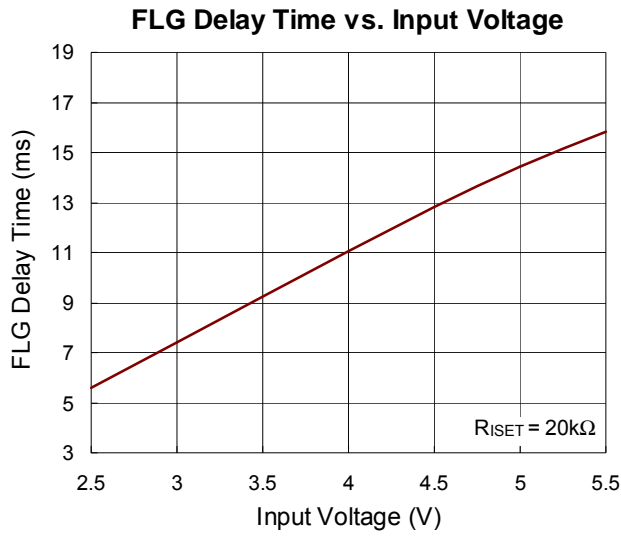

Applications Information

Richtek's component specification does not include the following information in the Application Information section. Thereby no warranty is given regarding its validity and accuracy. Customers should take responsibility to verify their own designs and to ensure the functional suitability of their components and systems.

The RT9731A/B are dual N-MOSFET high side power switch with enable input, optimized for self-powered and bus-powered Universal Serial Bus (USB) applications. The RT9731A/B are equipped with a charge pump circuitry to drive the internal N-MOSFET switch; the switch's low $R_{DS(ON)}$, 44m Ω , meets USB voltage drop requirements; and a flag output is available to indicate fault conditions to the local USB controller.

Input and Output

V_{IN} (input) is the power source connection to the internal circuitry and the drain of the MOSFET. V_{OUT} (output) is the source of the MOSFET. In a typical application, current flows through the switch from V_{IN} to V_{OUT} toward the load. If V_{OUT} is greater than V_{IN} , current will flow from V_{OUT} to V_{IN} since the MOSFET is bidirectional when on.

Unlike a normal MOSFET, there is no parasitic body diode between drain and source of the MOSFET, the RT9731A/B prevents reverse current flow if V_{OUT} is externally forced to a higher voltage than V_{IN} when the chip is disabled ($V_{ENx} < 0.66V$ or $V_{\overline{ENx}} > 1.1V$).

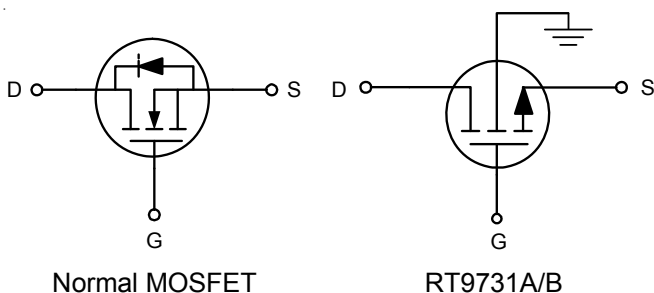

Chip Enable Input

The switch will be disabled when the ENx/\overline{ENx} pin is in a logic low/high condition. During this condition, the internal circuitry and MOSFET will be turned off, reducing the supply current to 0.1 μ A typical. Floating the ENx/\overline{ENx} may cause unpredictable operation. ENx/\overline{ENx} should not be allowed to go negative with respect to GND. The ENx/\overline{ENx} pin may be directly tied to V_{IN} (GND) to keep the part on.

Soft-Start for Hot Plug-In Applications

In order to eliminate the upstream voltage droop caused by the large inrush current during hot-plug events, the "soft-start" feature effectively isolates the power source from extremely large capacitive loads, satisfying the USB voltage droop requirements.

Fault Flag

The RT9731A/B series provides a \overline{FLAGx} signal pin which is an N-Channel open drain MOSFET output. This open drain output goes low when current limit or the die temperature exceeds 120°C approximately. The \overline{FLAGx} output is capable of sinking a 10mA load to typically 200mV above ground. The \overline{FLAGx} pin requires a pull-up resistor, this resistor should be large in value to reduce energy drain. A 100k Ω pull-up resistor works well for most applications. In the case of an over-current condition, \overline{FLAGx} will be asserted only after the flag response delay time, t_D , has elapsed. This ensures that \overline{FLAGx} is asserted only upon valid over current conditions and that erroneous error reporting is eliminated.

For example, false over-current conditions may occur during hot-plug events when extremely large capacitive loads are connected and causes a high transient inrush current that exceeds the current limit threshold. The \overline{FLAGx} response delay time t_D is typically 12ms.

Under Voltage Lockout

Under Voltage Lockout (UVLO) prevents the MOSFET switch from turning on until the input voltage exceeds approximately 2.35V. If input voltage drops below approximately 1.3V, UVLO turns off the MOSFET switch. Under voltage detection functions only when the switch is enabled.

Current Limit Setting and Short-Circuit Protection

The RT9731A/B provides an adjustable current limit threshold, between 560mA and 2.8A (typ.) via an external resistor, R_{SET} , between 20k Ω and 100k Ω . The following

equations calculates the resulting over current threshold for a given external resistor value (R_{ISET}). The traces routing the R_{ISET} resistor to the RT9731A/B should be as short as possible to reduce parasitic effects on the current limit accuracy. When a heavy load or short circuit is applied to an enabled switch, a large transient current may flow until the current limit circuitry responds. Once this current limit threshold is exceeded the device enters constant current mode until the thermal shutdown occurs or the fault is removed. Figure 1 shows the typical current limit value under various setting resistance, R_{ISET} .

$$I_{SET(typ.)} (mA) = \frac{56000V}{R_{ISET}k\Omega}$$

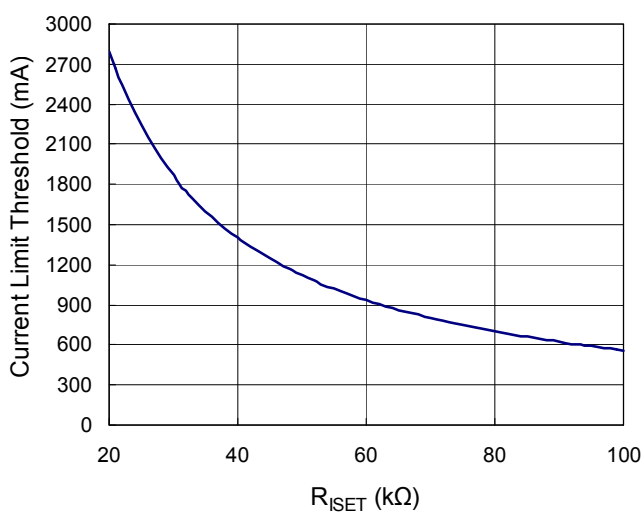

Figure 1. Current Limit Threshold vs. R_{ISET}

Universal Serial Bus (USB) & Power Distribution

The goal of USB is to enable device from different vendors to interoperate in an open architecture. USB features include ease of use for the end user, a wide range of workloads and applications, robustness, synergy with the PC industry, and low-cost implementation. Benefits include self-identifying peripherals, dynamically attachable and reconfigurable peripherals, multiple connections (support for concurrent operation of many devices), support for as many as 127 physical devices, and compatibility with PC Plug-and-Play architecture.

The Universal Serial Bus connects USB devices with a USB host: each USB system has one USB host. USB devices are classified either as hubs, which provide additional attachment points to the USB, or as functions,

which provide capabilities to the system (for example, a digital joystick). Hub devices are then classified as either Bus-Power Hubs or Self-Powered Hubs.

A Bus-Powered Hub draws all of the power to any internal functions and downstream ports from the USB connector power pins. The hub may draw up to 500mA from the upstream device. External ports in a Bus-Powered Hub can supply up to 100mA per port, with a maximum of four external ports.

Self-Powered Hub power for the internal functions and downstream ports does not come from the USB, although the USB interface may draw up to 100mA from its upstream connect to allow the interface to function when the remainder of the hub is powered down. The hub must be able to supply up to 500mA on all of its external downstream ports. Please refer to “Universal Serial Bus Specification Revision 2.0” for more details on designing compliant USB hub and host systems.

Over current protection devices such as fuses and PTC resistors (also called polyfuse or polyswitch) have slow trip times, high on-resistance, and lack the necessary circuitry for USB-required fault reporting.

The faster trip time of the RT9731A/B power distribution allow designers to design hubs that can operate through faults. The RT9731A/B provide low on-resistance and internal fault-reporting circuitry to meet voltage regulation and fault notification requirements.

Because the devices are also power switches, the designer of self-powered hubs has the flexibility to turn off power to output ports. Unlike a normal MOSFET, the devices have controlled rising and falling times to provide the needed inrush current limiting required for the bus-powered hub power switch.

Supply Filter/Bypass Capacitor

A 0.1μF or greater low-ESR ceramic capacitor from V_{IN} to GND, located at the device is strongly recommended to prevent the input voltage drooping during hot-plug events. However, higher capacitor values will further reduce the voltage droop on the input. Furthermore, without the bypass capacitor, an output short may cause sufficient ringing on the input (from source lead inductance) to destroy the internal control circuitry. The input transient

must not exceed 6V of the absolute maximum supply voltage even for a short duration.

Output Filter Capacitor

A low-ESR 150µF capacitor between V_{OUT} and GND is strongly recommended to meet the 330mV maximum droop requirement in the hub V_{BUS} (Per USB 2.0, output ports must have a minimum 120µF of low-ESR bulk capacitance per hub). Standard bypass methods should be used to minimize inductance and resistance between the bypass capacitor and the downstream connector to reduce EMI and decouple voltage droop caused when downstream cables are hot-insertion transients. Ferrite beads in series with V_{BUS}, the ground line and the 0.1µF bypass capacitors at the power connector pins are recommended for EMI and ESD protection. The bypass capacitor itself should have a low dissipation factor to allow decoupling at higher frequencies.

Voltage Drop

The USB specification states a minimum port-output voltage in two locations on the bus, 4.75V out of a Self-Powered Hub port and 4.4V out of a Bus-Powered Hub port. As with the Self-Powered Hub, all resistive voltage drops for the Bus-Powered Hub must be accounted for to guarantee voltage regulation (see Figure 7-47 of “Universal Serial Bus Specification Revision 2.0”).

The following calculation determines V_{OUT(MIN)} for multiple ports (N_{PORTS}) ganged together through one switch (if using one switch per port, N_{PORTS} is equal to 1) :

$$V_{OUT(MIN)} = 4.75V - [I_L \times (4 \times R_{CONN} + 2 \times R_{CABLE})] - (0.1A \times N_{PORTS} \times R_{SWITCH}) - V_{PCB}$$

Where

R_{CONN} = Resistance of connector contacts
(two contacts per connector)

R_{CABLE} = Resistance of upstream cable wires
(one 5V and one GND)

R_{SWITCH} = Resistance of power switch
(44mΩ typical for RT9731A/B)

V_{PCB} = PCB voltage drop

The USB specification defines the maximum resistance per contact (R_{CONN}) of the USB connector to be 30mΩ and the drop across the PCB and switch to be 100mV. This basically leaves two variables in the equation : the resistance of the switch and the resistance of the cable.

If the hub consumes the maximum current (I_L) of 500mA, the maximum resistance of the cable is 90mΩ.

The resistance of the switch can be defined as follows :

$$R_{SWITCH} = \{ 4.75V - 4.4V - [0.5A \times (4 \times 30m\Omega + 2 \times 90m\Omega)] - V_{PCB} \} \div (0.1A \times N_{PORTS})$$

$$= (200mV - V_{PCB}) \div (0.1A \times N_{PORTS})$$

If the voltage drop across the PCB is limited to 100mV, the maximum resistance for the switch is 250mΩ for four ports ganged together. The RT9731A/B, with its maximum 50mΩ on-resistance over temperature can fit the demand of this requirement.

Thermal Shutdown

Thermal protection limits power dissipation in the RT9731A/B. When the operation junction temperature exceeds 120°C (typ.), the OTP circuit starts the thermal shutdown function and turns the pass element off. The pass element turns on again after the junction temperature cools to 80°C. The IC lowers its OTP trip level from 120°C to 100°C when output short circuit occurs (V_{OUT} < 1V) as shown in Figure 2.

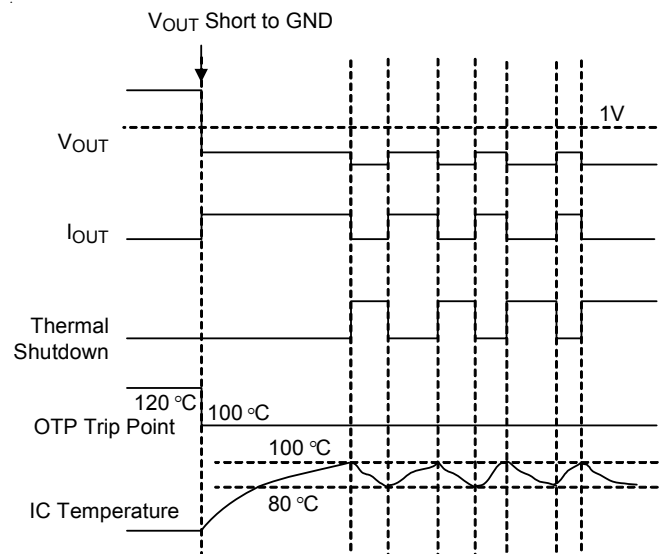

Figure 2. Short Circuit Thermal Folded Back Protection when Output Short Circuit Occurs (Patent)

Thermal Considerations

For continuous operation, do not exceed absolute maximum operation junction temperature. The maximum power dissipation depends on the thermal resistance of IC package, PCB layout, the rate of surroundings airflow and temperature difference between junction to ambient. The maximum power dissipation can be calculated by following formula :

$$P_{D(MAX)} = (T_{J(MAX)} - T_A) / \theta_{JA}$$

where $T_{J(MAX)}$ is the maximum operation junction temperature, T_A is the ambient temperature and the θ_{JA} is the junction to ambient thermal resistance.

For recommended operating conditions specification. The maximum junction temperature is 125°C. The junction to ambient thermal resistance θ_{JA} is layout dependent. For WDFN-10L 3x3 package, the thermal resistance θ_{JA} is 70°C/W on a standard JEDEC 51-7 four-layer thermal test board. The maximum power dissipation at $T_A = 25^\circ\text{C}$ can be calculated by the following formula :

$$P_{D(MAX)} = (125^\circ\text{C} - 25^\circ\text{C}) / (70^\circ\text{C/W}) = 1.429\text{W for WDFN-10L 3x3 packages}$$

The maximum power dissipation depends on operating ambient temperature for fixed $T_{J(MAX)}$ and thermal resistance θ_{JA} . The Figure 3 of derating curves allows the designer to see the effect of rising ambient temperature on the maximum power dissipation.

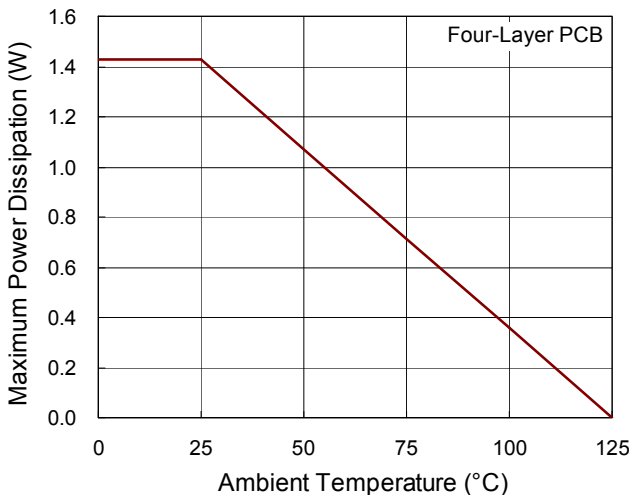

Figure 3. Derating Curve of Maximum Power Dissipation

Layout Consideration

For best performance of the RT9731A/B series, the following guidelines must be strictly followed.

- ▶ Input and output capacitors should be placed close to the IC and connected to ground plane to reduce noise coupling.
- ▶ The GND should be connected to a strong ground plane for heat sink.
- ▶ Keep the main current traces as possible as short and wide.
- ▶ The R_{ISET} resistor should be placed as close to the IC as possible.

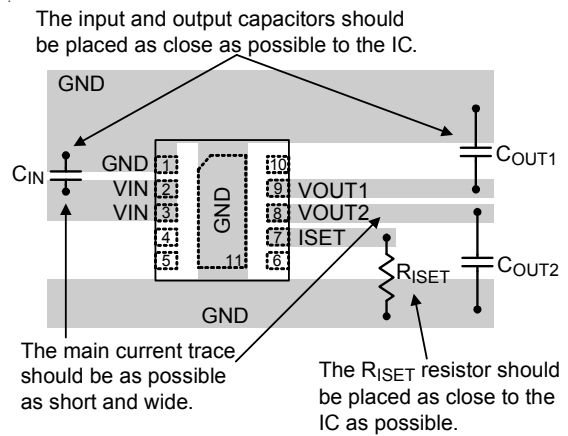
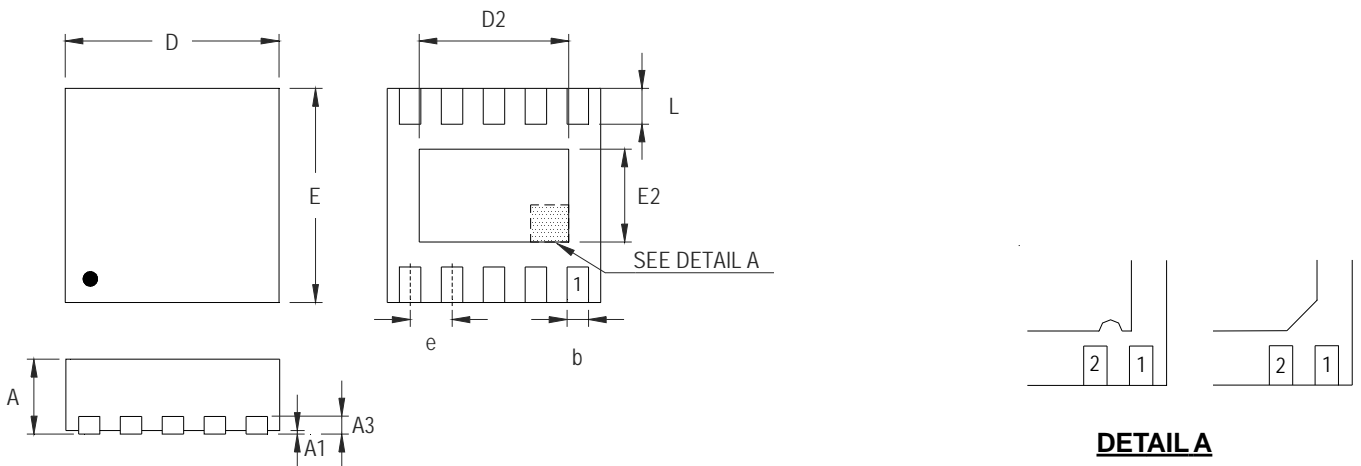

Figure 4. PCB Layout Guide

Outline Dimension



DETAIL A

Pin #1 ID and Tie Bar Mark Options

Note : The configuration of the Pin #1 identifier is optional, but must be located within the zone indicated.

Symbol	Dimensions In Millimeters		Dimensions In Inches	
	Min	Max	Min	Max
A	0.700	0.800	0.028	0.031
A1	0.000	0.050	0.000	0.002
A3	0.175	0.250	0.007	0.010
b	0.180	0.300	0.007	0.012
D	2.950	3.050	0.116	0.120
D2	2.300	2.650	0.091	0.104
E	2.950	3.050	0.116	0.120
E2	1.500	1.750	0.059	0.069
e	0.500		0.020	
L	0.350	0.450	0.014	0.018

W-Type 10L DFN 3x3 Package

Richtek Technology Corporation

14F, No. 8, Tai Yuen 1st Street, Chupei City
 Hsinchu, Taiwan, R.O.C.
 Tel: (8863)5526789



Richtek products are sold by description only. Richtek reserves the right to change the circuitry and/or specifications without notice at any time. Customers should obtain the latest relevant information and data sheets before placing orders and should verify that such information is current and complete. Richtek cannot assume responsibility for use of any circuitry other than circuitry entirely embodied in a Richtek product. Information furnished by Richtek is believed to be accurate and reliable. However, no responsibility is assumed by Richtek or its subsidiaries for its use; nor for any infringements of patents or other rights of third parties which may result from its use. No license is granted by implication or otherwise under any patent or patent rights of Richtek or its subsidiaries.

Datasheet Revision History

Version	Date	Description	Item
03	2023/4/19	Modify	Absolute Maximum Ratings on P4 Removed ESD MM on P4 Applications Information on P9

Looking for pricing, stock, or lifecycle information?

Click below to explore more details on WIN SOURCE:

-  [View RT9731AZQW\(2\) on WIN SOURCE](#)
-  [Richtek USA Inc. Information](#)

Optimize Your Supply Chain with WIN SOURCE Solutions

-  Global Sourcing Solution
-  Obsolete Management
-  Cost Control Management
-  Shortage Management
-  Alternative Solution
-  Excess Inventory Management