



**THE DATASHEET OF
AZ809NSTR-E1**



**3-PIN MICROPROCESSOR RESET CIRCUITS****AZ809/AZ810****General Description**

The AZ809/810 microprocessor supervisory circuits can be used to monitor the power supplies in microprocessor and digital systems. They provide a reset to the microprocessor in power-up, power-down and brown-out conditions. The function of the AZ809/810 is to monitor the V_{CC} supply voltage, and assert a reset signal whenever this voltage declines below the factory-programmed reset threshold. The reset signal remains asserted for 240ms after V_{CC} rises above the threshold. The AZ809 has an active-low RESET output, while the AZ810 has an active-high RESET output. Seven standard reset voltage options are available, suitable for monitoring 3.0V, 3.3V and 5.0V supply voltages. With a typical supply current of only 8 μ A when V_{CC} is 3.3V, the AZ809/810 are ideal for use in portable equipment.

These ICs are available in SOT-23 package.

Features

- Precise Monitoring of 3.0V, 3.3V and 5.0V Supply Voltages
- Improved Maxim MAX809/MAX810 Replacement
- 140ms Min. Reset Pulse Width
- Active-low Reset Output (AZ809)
- Active-high Reset Output (AZ810)
- No External Components
- Specified Over Full Temperature Range: -40 to 105°C

Applications

- Embedded Controllers
- Battery Operated Systems
- Intelligent Instruments
- Wireless Communication Systems
- PDAs and Handheld Equipment



Figure 1. Package Type of AZ809/810

3-PIN MICROPROCESSOR RESET CIRCUITS

AZ809/AZ810

Pin Configuration

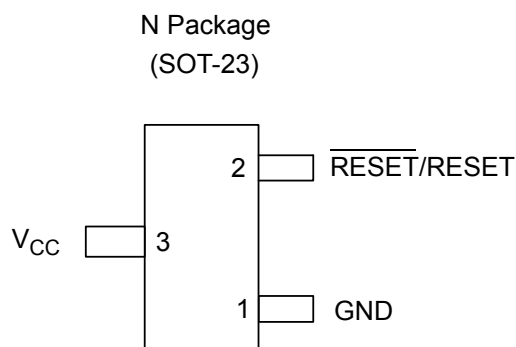

Figure 2. Pin Configuration of AZ809/810 (Top View)

Pin Description

Pin Number		Pin Name	Function
AZ809	AZ810		
1	1	GND	Ground pin
2		$\overline{\text{RESET}}$	$\overline{\text{RESET}}$ is asserted LOW if V_{CC} falls below the reset threshold and remains LOW for the 240ms typical reset timeout period (140ms minimum) after V_{CC} exceeds the threshold
	2	RESET	RESET is asserted HIGH if V_{CC} falls below the reset threshold
3	3	V_{CC}	Power supply input voltage (3.0V, 3.3V, 5.0V)

3-PIN MICROPROCESSOR RESET CIRCUITS

AZ809/AZ810

Functional Block Diagram

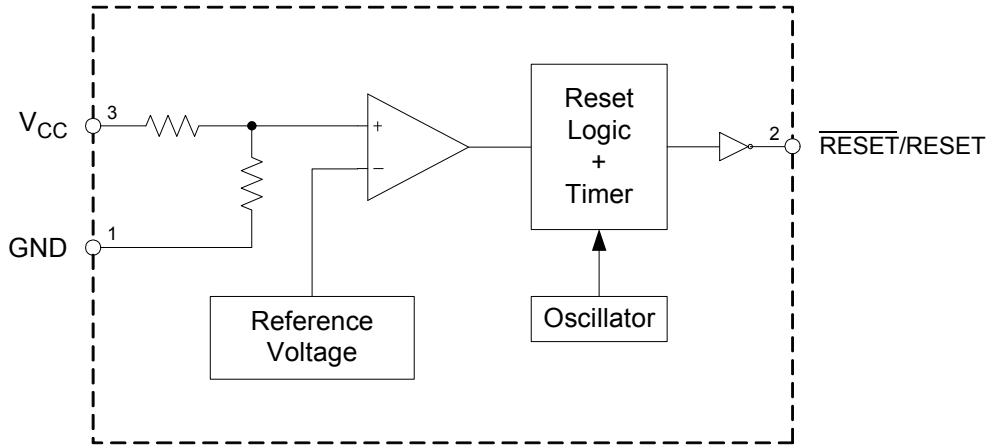

Figure 3. Functional Block Diagram of AZ809/810

Ordering Information

	AZ8XX □ □ □ - □									
Circuit Type	<table border="0" style="margin-left: 20px;"> <tr> <td style="border-top: 1px solid black; width: 20px;"></td> <td style="border-top: 1px solid black; width: 20px;"></td> <td style="border-top: 1px solid black; width: 20px;"></td> <td style="border-top: 1px solid black; width: 20px;"></td> </tr> <tr> <td style="border-bottom: 1px solid black;"></td> <td style="border-bottom: 1px solid black;"></td> <td style="border-bottom: 1px solid black;"></td> <td style="border-bottom: 1px solid black;"></td> </tr> </table>									E1: Lead Free G1: Green
09: AZ809 10: AZ810	<table border="0" style="margin-left: 20px;"> <tr> <td style="border-top: 1px solid black; width: 20px;"></td> <td style="border-top: 1px solid black; width: 20px;"></td> <td style="border-top: 1px solid black; width: 20px;"></td> <td style="border-top: 1px solid black; width: 20px;"></td> </tr> <tr> <td style="border-bottom: 1px solid black;"></td> <td style="border-bottom: 1px solid black;"></td> <td style="border-bottom: 1px solid black;"></td> <td style="border-bottom: 1px solid black;"></td> </tr> </table>									TR: Tape and Reel
Package N: SOT-23	<table border="0" style="margin-left: 20px;"> <tr> <td style="border-top: 1px solid black; width: 20px;"></td> <td style="border-top: 1px solid black; width: 20px;"></td> <td style="border-top: 1px solid black; width: 20px;"></td> <td style="border-top: 1px solid black; width: 20px;"></td> </tr> <tr> <td style="border-bottom: 1px solid black;"></td> <td style="border-bottom: 1px solid black;"></td> <td style="border-bottom: 1px solid black;"></td> <td style="border-bottom: 1px solid black;"></td> </tr> </table>									Detect Voltage: L: 4.63V S: 2.93V T: 3.08V R: 2.63V

**3-PIN MICROPROCESSOR RESET CIRCUITS****AZ809/AZ810****Ordering Information (Continued)**

Package	Temperature Range	Part Number		Marking ID		Packing Type
		Lead Free	Green	Lead Free	Green	
SOT-23	-40 to 105°C	AZ809NLTR-E1	AZ809NLTR-G1	EC1	GC1	Tape & Reel
		AZ809NTTR-E1	AZ809NTTR-G1	EC4	GC4	Tape & Reel
		AZ809NSTR-E1	AZ809NSTR-G1	EC5	GC5	Tape & Reel
		AZ809NRTR-E1	AZ809NRTR-G1	EC6	GC6	Tape & Reel
	-40 to 105°C	AZ810NLTR-E1	AZ810NLTR-G1	ED1	GD1	Tape & Reel
		AZ810NTTR-E1	AZ810NTTR-G1	ED4	GD4	Tape & Reel
		AZ810NSTR-E1	AZ810NSTR-G1	ED5	GD5	Tape & Reel
		AZ810NRTR-E1	AZ810NRTR-G1	ED6	GD6	Tape & Reel

BCD Semiconductor's Pb-free products, as designated with "E1" suffix in the part number, are RoHS compliant. Products with "G1" suffix are available in green packages.

Absolute Maximum Ratings (Note 1)

Parameter	Symbol	Value	Unit
Supply Voltage	V_{CC}	-0.3 to 6	V
$\overline{\text{RESET}}$, RESET		-0.3 to $V_{CC}+0.3$	V
Input Current, V_{CC} Pin		20	mA
Output Current, $\overline{\text{RESET}}$, RESET Pin		20	mA
Rate of Rise, V_{CC}		100	V/ μ s
Continuous Power Dissipation		320	mW
Junction Temperature	T_J	125	°C
Storage Temperature	T_{STG}	-65 to 150	°C
Lead Temperature (Soldering, 10sec)	T_{LEAD}	300	°C

Note 1: Stresses greater than those listed under "Absolute Maximum Ratings" may cause permanent damage to the device. These are stress ratings only, and functional operation of the device at these or any other conditions beyond those indicated under "Recommended Operating Conditions" is not implied. Exposure to "Absolute Maximum Ratings" for extended periods may affect device reliability.

Recommended Operating Conditions

Parameter	Symbol	Min	Max	Unit
Operating Junction Temperature Range	T_J	-40	105	°C



3-PIN MICROPROCESSOR RESET CIRCUITS

AZ809/AZ810

Electrical Characteristics

($T_A = -40^{\circ}\text{C}$ to 105°C , Typical values at $T_A = 25^{\circ}\text{C}$, $V_{CC} = 5\text{V}$ for L devices, $V_{CC} = 3.3\text{V}$ for T/S devices and $V_{CC} = 3\text{V}$ for R devices, unless otherwise specified.)

Parameter	Symbol	Conditions	Min	Typ	Max	Unit	
Input Voltage (V_{CC}) Range	V_{CC}	$T_A = 0^{\circ}\text{C}$ to 70°C	1.1		5.5	V	
		$T_A = -40^{\circ}\text{C}$ to 105°C	1.2		5.5		
Supply Current	I_{CC}	$T_A = -40^{\circ}\text{C}$ to 85°C , $V_{CC} < 5.5\text{V}$, L		11	20	μA	
		$T_A = -40^{\circ}\text{C}$ to 85°C , $V_{CC} < 3.6\text{V}$, R/S/T		8	16		
		$T_A = 85^{\circ}\text{C}$ to 105°C , $V_{CC} < 5.5\text{V}$, L			25		
		$T_A = 85^{\circ}\text{C}$ to 105°C , $V_{CC} < 3.6\text{V}$, R/S/T			20		
Detect Voltage	V_{TH}	L Devices L: 4.63V	$T_A = 25^{\circ}\text{C}$	4.56	4.63	4.70	V
			$T_A = -40^{\circ}\text{C}$ to 85°C	4.50		4.75	
			$T_A = 85^{\circ}\text{C}$ to 105°C	4.40		4.86	
		T Devices T: 3.08V	$T_A = 25^{\circ}\text{C}$	3.04	3.08	3.11	
			$T_A = -40^{\circ}\text{C}$ to 85°C	3.00		3.15	
			$T_A = 85^{\circ}\text{C}$ to 105°C	2.92		3.23	
		S Devices S: 2.93V	$T_A = 25^{\circ}\text{C}$	2.89	2.93	2.96	
			$T_A = -40^{\circ}\text{C}$ to 85°C	2.85		3.00	
			$T_A = 85^{\circ}\text{C}$ to 105°C	2.78		3.08	
		R Devices R: 2.63V	$T_A = 25^{\circ}\text{C}$	2.59	2.63	2.66	
			$T_A = -40^{\circ}\text{C}$ to 85°C	2.55		2.70	
			$T_A = 85^{\circ}\text{C}$ to 105°C	2.50		2.76	
Detect Voltage Temperature Coefficient				± 0.003		$\% / ^{\circ}\text{C}$	
V_{CC} to Reset Delay		$V_{CC} = V_{TH}$ to $V_{TH} - 100\text{mV}$		20		μs	



3-PIN MICROPROCESSOR RESET CIRCUITS

AZ809/AZ810

Electrical Characteristics (Continued)

($T_A = -40^{\circ}\text{C}$ to 105°C , Typical values at $T_A = 25^{\circ}\text{C}$, $V_{CC} = 5\text{V}$ for L devices, $V_{CC} = 3.3\text{V}$ for T/S devices and $V_{CC} = 3\text{V}$ for R devices, unless otherwise specified.)

Parameter	Symbol	Conditions	Min	Typ	Max	Unit
Reset Active Timeout Period		$T_A = -40^{\circ}\text{C}$ to 85°C	140	240	560	ms
		$T_A = 85^{\circ}\text{C}$ to 105°C	100		840	
Low $\overline{\text{RESET}}$ Output Voltage (AZ809)	V_{OL}	$V_{CC} = V_{TH}$ min, $I_{SINK} = 1.2\text{mA}$, AZ809R/S/T			0.3	V
		$V_{CC} = V_{TH}$ min, $I_{SINK} = 3.2\text{mA}$, AZ809L			0.4	
		$V_{CC} > 1.1\text{V}$, $I_{SINK} = 50\mu\text{A}$			0.3	
High $\overline{\text{RESET}}$ Output Voltage (AZ809)		$V_{CC} > V_{TH}$ max, $I_{SOURCE} = 500\mu\text{A}$, AZ809R/S/T	$0.8V_{CC}$			V
		$V_{CC} > V_{TH}$ max, $I_{SOURCE} = 800\mu\text{A}$, AZ809L	$V_{CC} - 1.5$			
Low RESET Output Voltage (AZ810)	V_{OL}	$V_{CC} = V_{TH}$ max, $I_{SINK} = 1.2\text{mA}$, AZ810R/S/T			0.3	V
		$V_{CC} = V_{TH}$ max, $I_{SINK} = 3.2\text{mA}$, AZ810L			0.4	
High RESET Output Voltage (AZ810)	V_{OH}	$1.8\text{V} < V_{CC} < V_{TH}$ min, $I_{SOURCE} = 150\mu\text{A}$	$0.8V_{CC}$			V

Operating Diagram

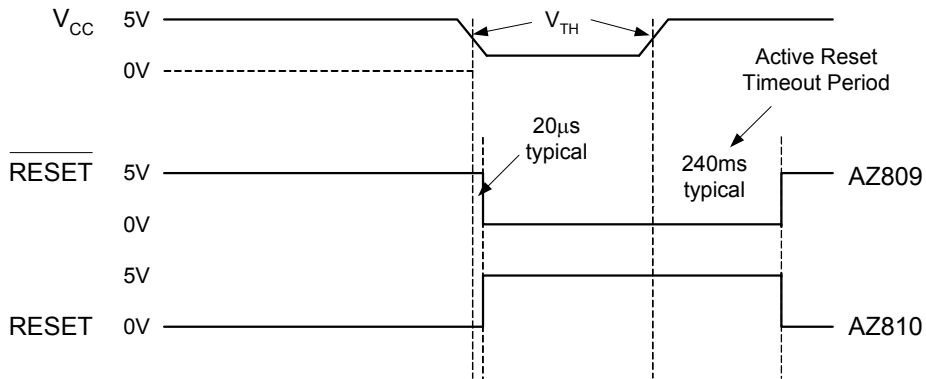

Note: The reset signal is asserted LOW for the AZ809 and HIGH for the AZ810 when the V_{CC} signal falls below the threshold trip voltage and remains asserted for 240ms typical after the V_{CC} has risen above the threshold.

Figure 4. Reset Timing Diagram of AZ809/810

Typical Application

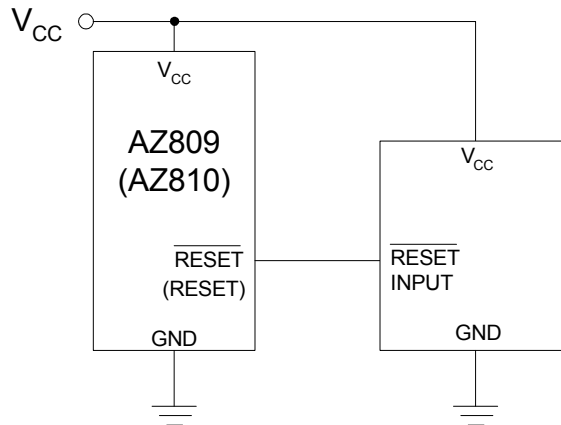

Figure 5. Typical Application of AZ809/810



BCD Semiconductor Manufacturing Limited

<http://www.bcdsemi.com>

IMPORTANT NOTICE

BCD Semiconductor Manufacturing Limited reserves the right to make changes without further notice to any products or specifications herein. BCD Semiconductor Manufacturing Limited does not assume any responsibility for use of any its products for any particular purpose, nor does BCD Semiconductor Manufacturing Limited assume any liability arising out of the application or use of any its products or circuits. BCD Semiconductor Manufacturing Limited does not convey any license under its patent rights or other rights nor the rights of others.

MAIN SITE

- Headquarters

BCD Semiconductor Manufacturing Limited

No. 1600, Zi Xing Road, Shanghai Zizhu Science-based Industrial Park, 200241, China
Tel: +86-21-24162266, Fax: +86-21-24162277

- Wafer Fab

Shanghai SIM-BCD Semiconductor Manufacturing Co., Ltd.

800 Yi Shan Road, Shanghai 200233, China
Tel: +86-21-6485 1491, Fax: +86-21-5450 0008

REGIONAL SALES OFFICE

Shenzhen Office

Shanghai SIM-BCD Semiconductor Manufacturing Co., Ltd., Shenzhen Office

Unit A Room 1203, Skyworth Bldg., Gaoxin Ave. 1.S., Nanshan District, Shenzhen, China
Tel: +86-755-8826 7951
Fax: +86-755-8826 7865

Taiwan Office

BCD Semiconductor (Taiwan) Company Limited

4F, 298-1, Rui Guang Road, Nei-Hu District, Taipei, Taiwan
Tel: +886-2-2656 2808
Fax: +886-2-2656 2806

USA Office

BCD Semiconductor Corp.

30920 Huntwood Ave. Hayward, CA 94544, USA
Tel : +1-510-324-2988
Fax: +1-510-324-2788

Looking for pricing, stock, or lifecycle information?

Click below to explore more details on WIN SOURCE:

- ⊖ [View AZ809NSTR-E1 on WIN SOURCE](#)
- ⊖ [Diodes Incorporated Information](#)

Optimize Your Supply Chain with WIN SOURCE Solutions

- ✓ Global Sourcing Solution
- ✓ Obsolete Management
- ✓ Cost Control Management
- ✓ Shortage Management
- ✓ Alternative Solution
- ✓ Excess Inventory Management