



**THE DATASHEET OF
LTC2943IDD#TRPBF**



Linduino One Isolated Arduino-Compatible Demonstration Board

DESCRIPTION

Linear Technology's DC2026 (called the Linduino[®] One) is compatible with the Arduino Uno microcontroller board. Arduino hardware consists of an Atmel microcontroller with a bootloader allowing quick in-circuit firmware updates. The software is a simple programming environment based on the AVRGCC compiler. This platform is popular because it is easy to use, both the hardware and software are open source, and it can be programmed in C. We find it an ideal way to demonstrate and distribute libraries for integrated circuits that have digital interfaces such as Inter-Integrated Circuit (I²C) and Serial Peripheral Interface (SPI). While the Linduino One is Arduino-compatible, it is not produced by the official Arduino team, and they do not receive any monetary support from this board. Please, consider supporting them by purchasing other items from: <http://store.arduino.cc>

LT, LT, LTC, LTM, Linear Technology, Linduino and the Linear logo are registered trademarks and QuikEval are trademarks of Linear Technology Corporation. All other trademarks are the property of their respective owners.

The Linduino One adds several features to the standard Arduino Uno board:

- A 14-pin QuikEval™ connector provides a direct connection to a growing list of hundreds of Linear Technology demo boards, including ADCs, DACs, Power System Management, RF Synthesizers, System Monitor and Control, and many others.
- Selectable 5V, 3.3V, 2.5V, 1.8V logic levels and analog supply on QuikEval Connector
- An LTM[®]2884 provides galvanic isolation of USB data and power for both safety and noise rejection.
- Auxiliary 7V to 20V power input on isolated side, with conversion to 5V provided by an LT[®]3973 allowing high power operation up to 750mA.

Design files for this circuit board are available at <http://www.linear.com/demo/DC2026C>

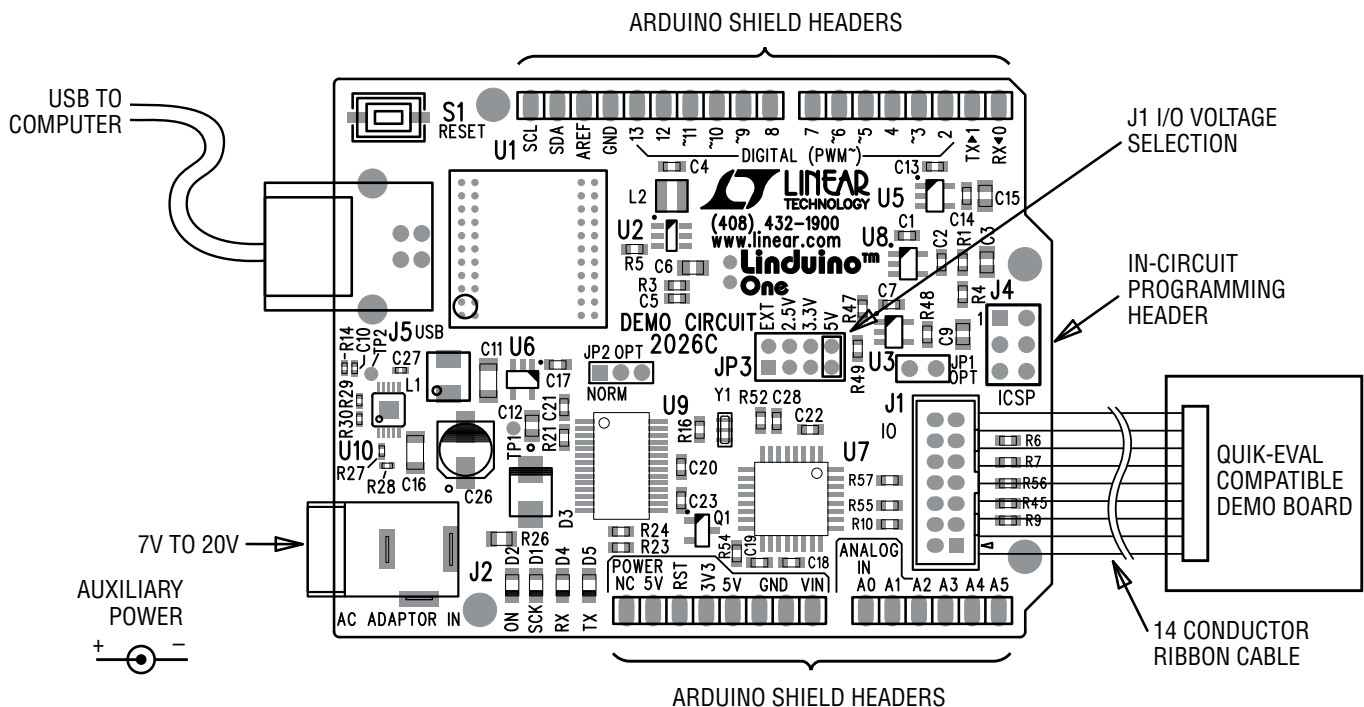

Figure 1. Linduino One Basic Connections

QUICK START GUIDE

The Linduino One comes preloaded with a DC590 emulator program (called a “sketch”) that allows attached demo boards to run with the standard QuikEval GUI software. This allows the functionality of the board to be verified before starting firmware development. After evaluation with QuikEval, the Linduino One can be reprogrammed with customer code. There is a top-level demonstration sketch for each part’s library that provides a text terminal interface to the board, demonstrating the library functions.

The Linduino One is also available as DC2026C-KIT, which includes a DC934 as an easy to use example daughter board. DC934 is the demonstration board for the LTC®2607 dual 16-bit, I²C digital to analog converter (DAC). This board also has an LTC2422 2-channel, 20-bit, SPI interface analog to digital converter (ADC) that reads back the DAC output. Thus, this board demonstrates operation of both SPI and I²C interfaces, and multichannel ADCs and DACs. The following sections describe the procedure for installing the required software and operating the DC934 with both QuikEval software and with a terminal based demo program.

While this manual describes operation with the DC934, the procedure applies to other boards as well.

Manual Software Installation

- 1) Download LTSketchbook.zip from www.linear.com/docs/43958. This is the entire code base for the Linduino board, including all demo code, libraries for individual devices, auxiliary functions, and HTML documentation. Extract this file to a location for working files, such as your “My Documents” directory or “C:\Projects”.
- 2) Note: If QuikEval is already installed, please update to the latest version by selecting Tools → Update Program, then proceed to step 3. If not, download and run QuikEval from www.linear.com/software. This installs the QuikEval program, as well as the FTDI USB drivers required for the Linduino One (and other Linear Technology interface boards.) Drivers are also distributed with the Arduino IDE, but it is recommended to let QuikEval install the drivers to ensure compatibility with the Linduino One. You will be prompted to connect the board to the PC during installation. Once the installation is complete, quit QuikEval.
- 3) Download the Arduino Integrated Development Environment (IDE) from either <http://arduino.cc/en/Main/Software> or <http://www.linear.com/designtools/linduino.php> (Version 1.6.4 is used in this manual.) This is not an installer; no installation is necessary. Extract the contents of this file to a convenient location for programs, such as “C:\Program Files”. The “Arduino.exe” file is the actual program file; double-click to open the Arduino IDE.

QUICK START GUIDE

Arduino IDE Setup

1) From within the Arduino IDE, click on File → Preferences

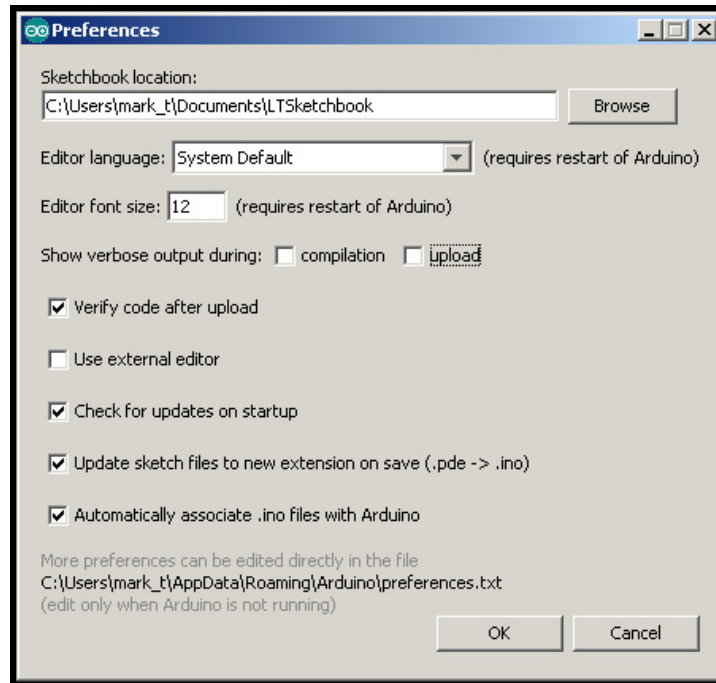

Under Sketchbook Location: select Browse, and locate the path to the extracted LTSketchbook.zip file. The correct location will show “LTSketchbook” in the Look In menu, and at least four subdirectories will be shown: Documentation, Libraries, Part Number and Utilities (more may be added in the future). Click Open, then click OK.

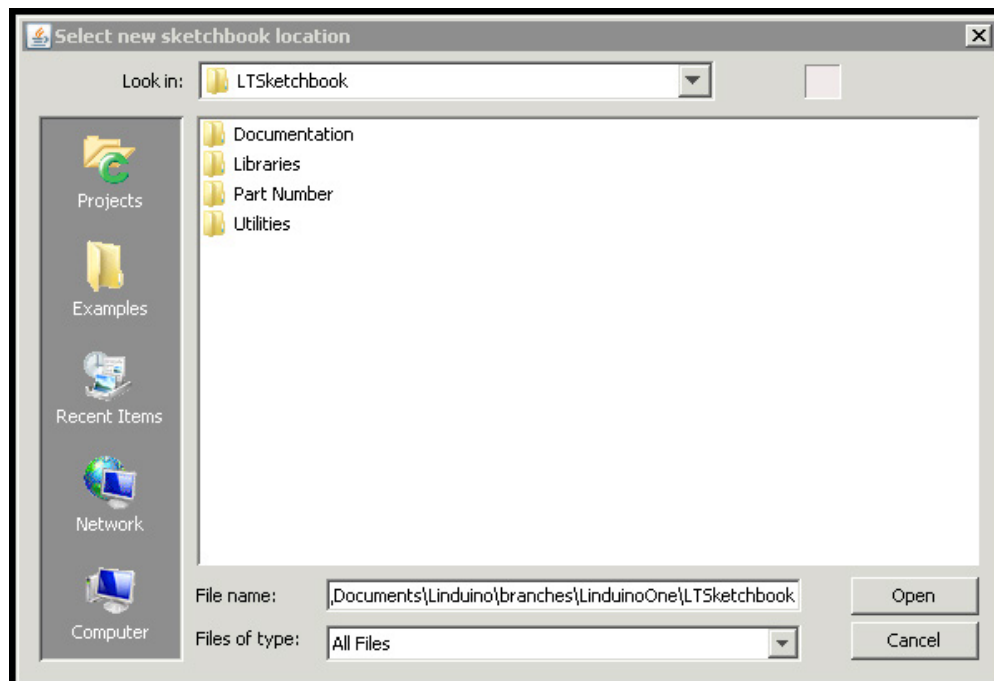

QUICK START GUIDE

2) Under **Tools** menu, select **Board** → **Arduino Uno**

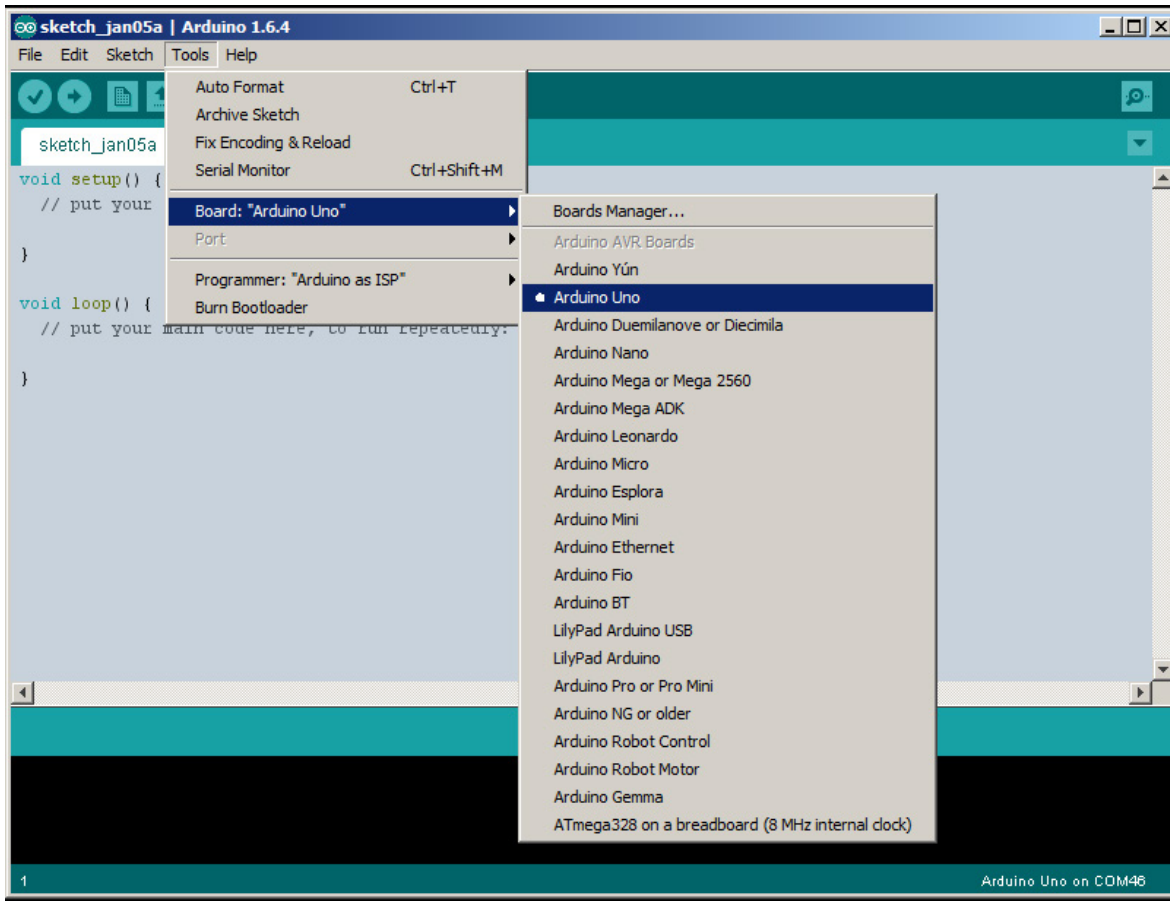

QUICK START GUIDE

- 3) Under the **Tools** menu, select **Serial Port**. There may be more than one option; the Linduino One is usually the highest COM port number (COM12 is shown below).

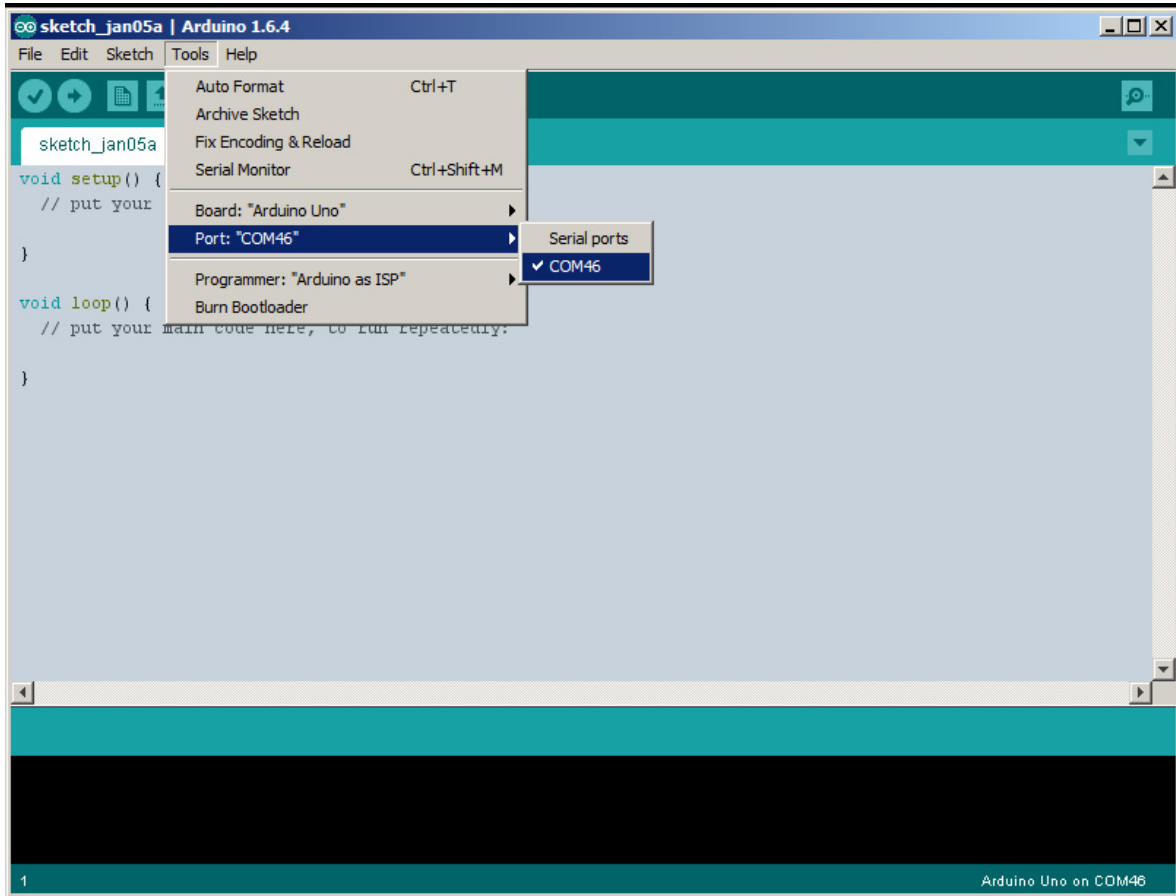

QUICK START GUIDE

4) Click on the Serial Monitor, which looks like a magnifying glass:



This will bring up the monitor window:



Select Newline terminator and set the baud rate to 115200. You should see a “hello” message – this indicates that serial communication is set up properly, and that the DC590 emulator firmware is properly installed. Pressing the RESET button on the Linduino One will cause the message to be sent again. If this message does not appear, try a different COM port.

(Note: The DC590 emulator sketch can be restored by following the procedure detailed below for uploading the DC934 sketch, substituting the DC590 sketch which is located in File → Sketchbook → Utilities → DC590B.)

5) Quit the Arduino IDE. Note that a restart is required every time the Sketchbook location is changed.

QUICK START GUIDE

Running with QuikEval

Linear Technology demo boards with the 14-pin QuikEval connector are normally used in conjunction with a DC590B interface board and the QuikEval software package running on a PC. Designers can then use the software to evaluate the performance of the product on the demo board. The Linduino One comes programmed with firmware that allows it to emulate the DC590B controller, so the QuikEval software can be used to check basic functionality in a target system.

Connect the DC934 to the Linduino One with the supplied 14-pin ribbon cable. Run QuikEval. The control panel for the LTC2607 will appear, and clicking COLLECT will start communication with the board. The onboard LTC2422 ADC reads back the output voltages, and the voltage may be changed by entering a number in the appropriate box or by moving the sliders.

Quit QuikEval after this step.

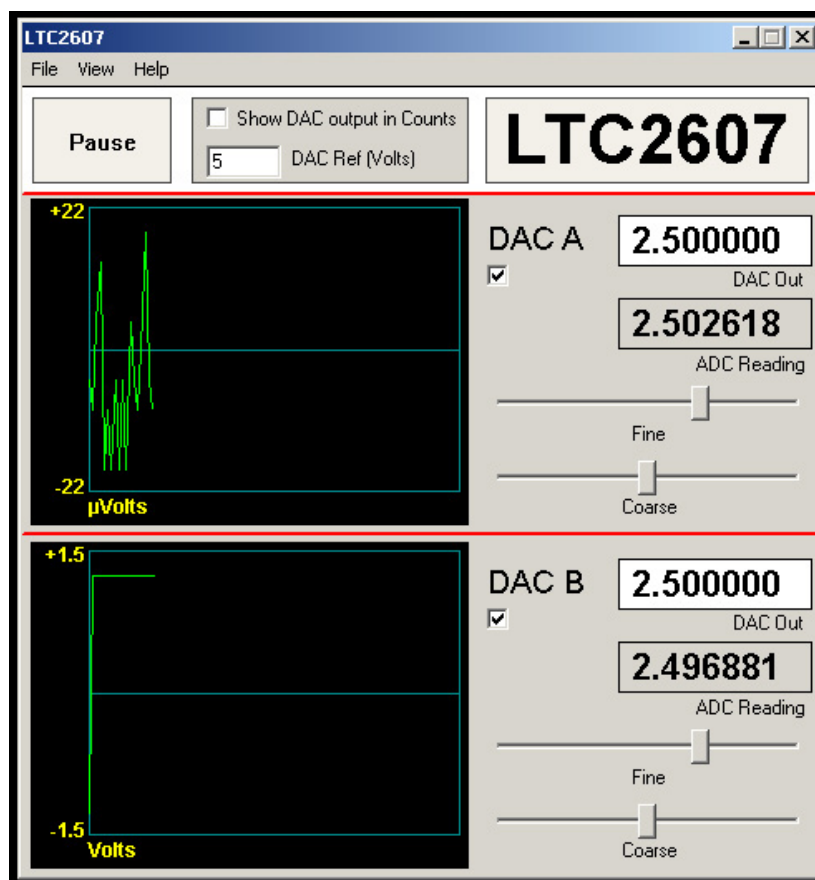

QUICK START GUIDE

Running with the Linduino Demonstration Program

After the DC934 has been run with the user-friendly QuikEval GUI, a demonstration program can be loaded into the Linduino One that demonstrates the library functions for the LTC2607 and LTC2422.

- 1) Open the Arduino IDE. Find the part number on the demo board, LTC2607 in this case. In the **File** menu select **Sketchbook** → **Part Number** → **2000** → **2600** → **2607** → **DC934A**.

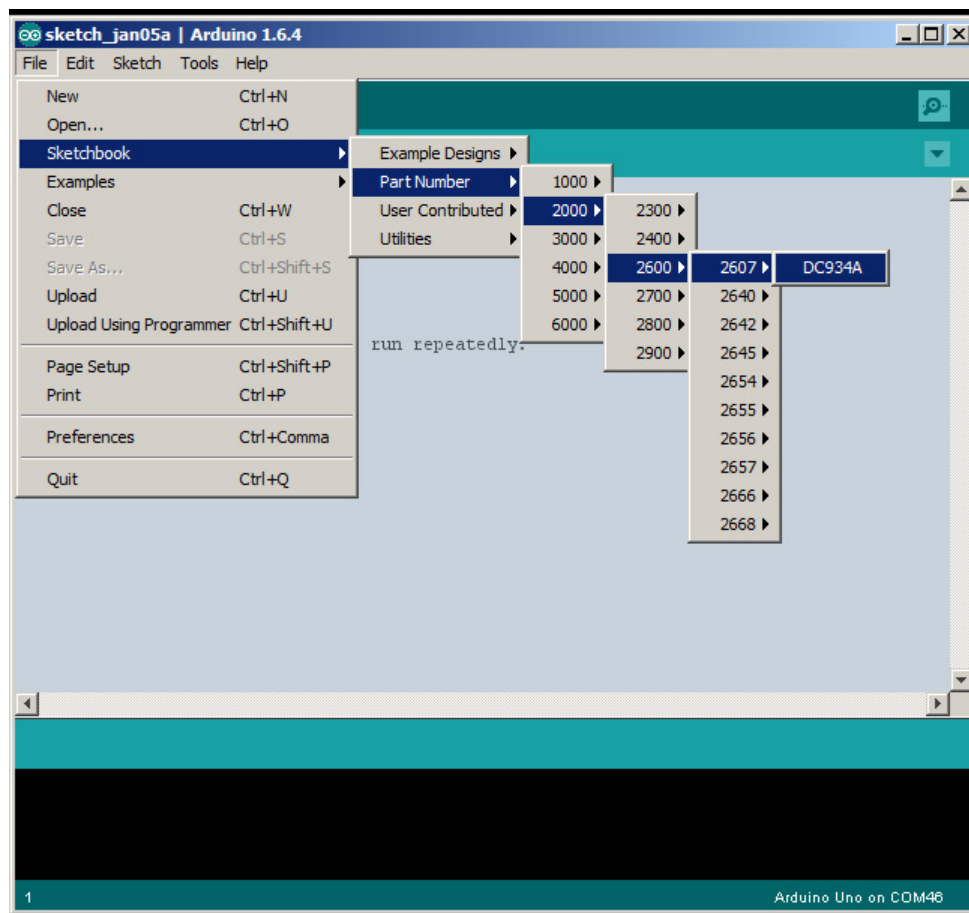

(There may be other entries for a particular part number showing example usage cases, experiments, etc. The entry for the demo circuit number is the general-purpose demonstration program and is a good place to start.)

QUICK START GUIDE

A new window will appear with the sketch.

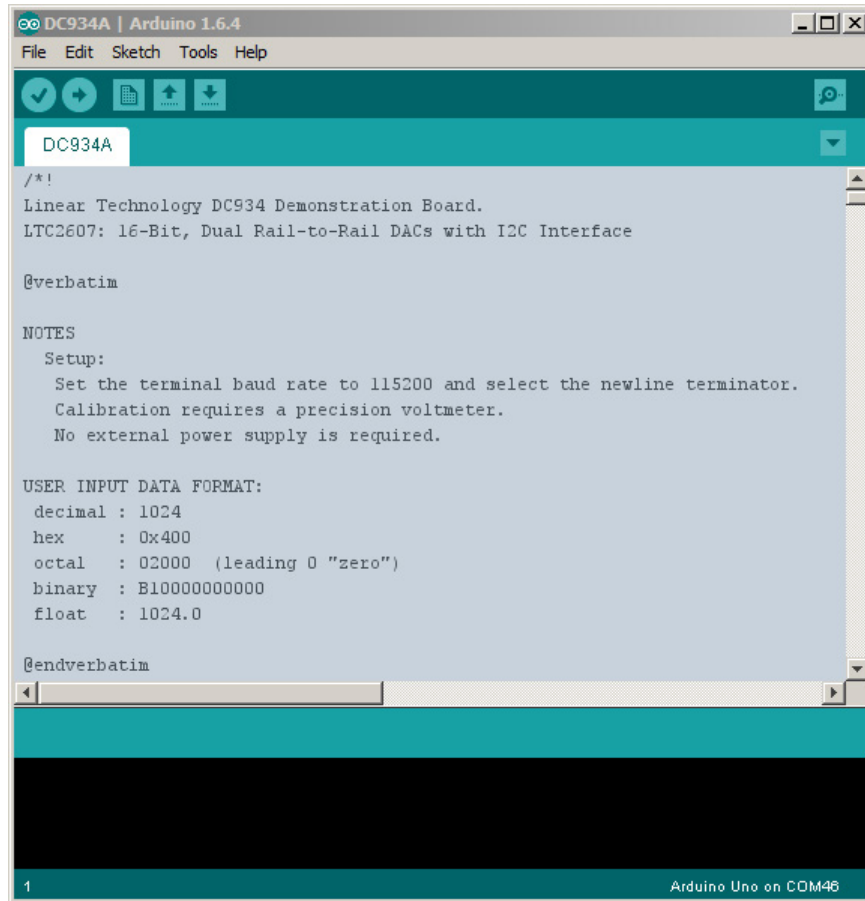

2) Upload the sketch by clicking the UPLOAD button:



When this process is completed, a message at the bottom should display a similar message as shown.

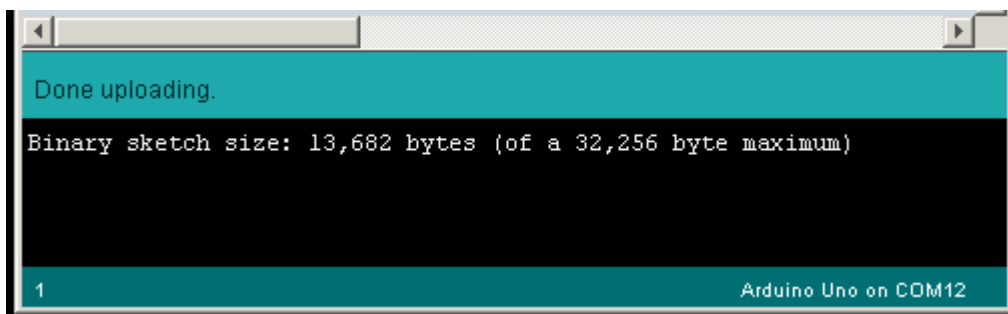

QUICK START GUIDE

3) Open the Serial Monitor (magnifying glass icon) once more. The monitor will now display the program interface.

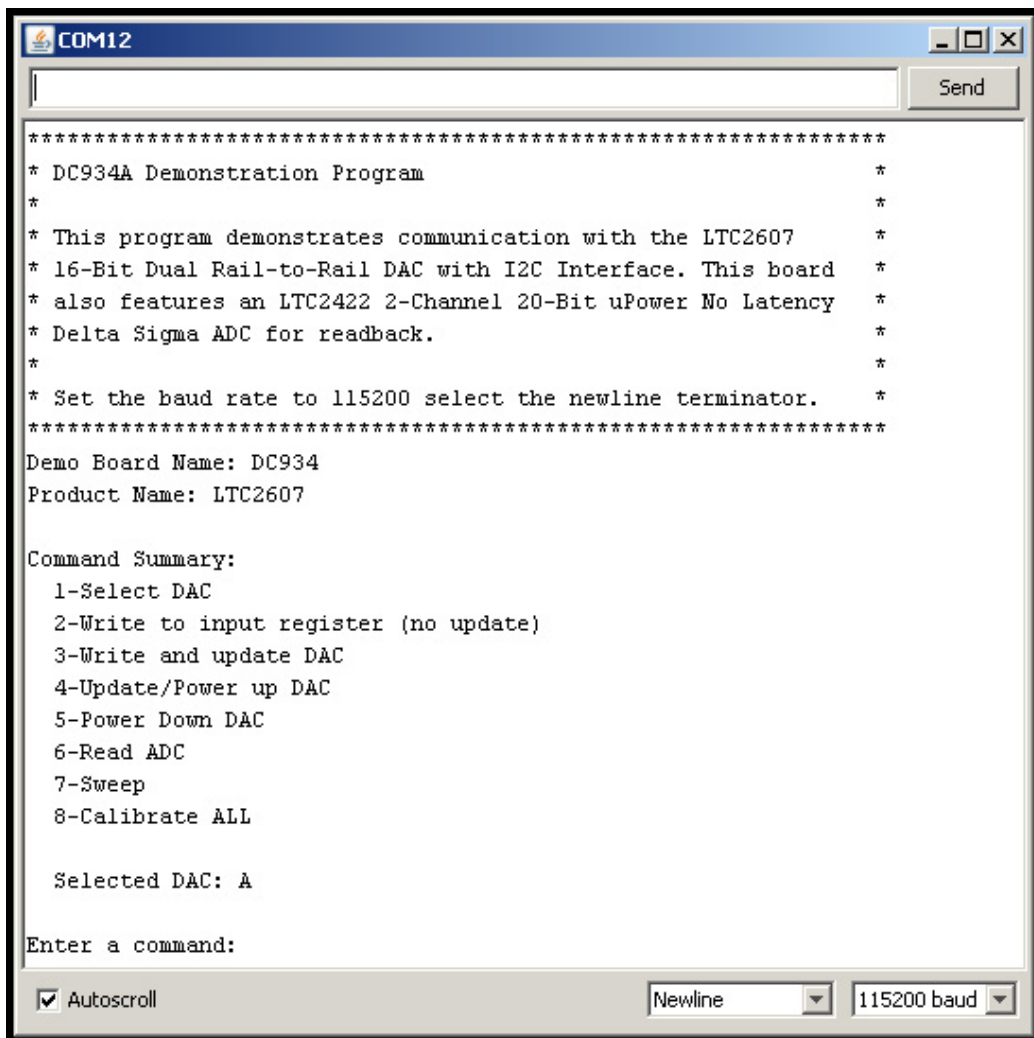

To use the program, enter commands into the text box, then click the Send button.



QUICK START GUIDE

Going Further

After completing the procedure in this Quick Start Guide, all of the tools are in place to move on to other products or further experimentation with the DC934. The main page for all Linduino resources is:

<http://www.linear.com/designtools/linduino.php>

HTML documentation for the code is provided in the sketchbook in the Documentation subdirectory.

External Connections

J1: QuikEval header – Connection to QuikEval demonstration board. This connector provides 5V at 50mA, 7.6V at 50mA, SPI and I²C interfaces, and an auxiliary I²C interface for identification of the attached demonstration board.

J2: AC ADAPTOR IN – 2.1mm × 5.5mm barrel connector. Optional DC power input, 7V to 20V DC. With external power applied, up to 750mA can be drawn from the 5V supply (available on pins 2 and 5 on J3, or pin 10 on J1.)

J3, J6, J7, J8: Arduino shield headers. These headers are compatible with standard Arduino “shield” add-on boards. Refer to schematic for individual signals.

J4: ICSP – In-circuit serial programming header. Used in conjunction with an external programming tool such as an AVR Dragon or JTAGICE3.

J5: USB – Connection to the host computer. Power for the Linduino and the connected daughter board is also taken from J5 if no external power is supplied to J2.

Jumpers

JP1: Factory use only.

JP2: Reset configuration, not installed. When the ICSP header is used with an external tool, install a 3 position, 0.1" header in this location and cut the trace labeled NORM on the back side of the board. Place jumper in the right-hand position (opposite to NORM) to allow the ICSP tool to control the RESET signal, install in the NORM position to allow the FT232 \overline{DTR} signal to control RESET (this is normal Arduino operation, and required to program the board from within the Arduino IDE.)

JP3: VCCIO selection 5V (default), 3.3V, 2.5V, remove for 1.8V, or EXT to disable the onboard regulator and supply VCCIO to the DC2026 from the attached demo board. Refer to the documentation for the attached demo board for information on acceptable voltage levels. VCCIO is the low-voltage supply for the attached demo board. It also sets the logic level for the SPI and I²C signals.

LEDs

ON: Lights when 5V supply is on, from which all other supply voltages are generated.

SCK: Lights when Arduino pin 13 (SCK on the SPI bus) is high. This is the pin used in the “blink” sketch under File → Examples → Basics → Blink.

RX: Lights when data is being received from the host computer through the USB port.

TX: Lights when data is being sent to the host computer through the USB port.

RESET Button (S1): Asserts the ATmega328's \overline{RESET} line, restarting program execution.

DEMO MANUAL DC2026C

BLOCK DIAGRAM

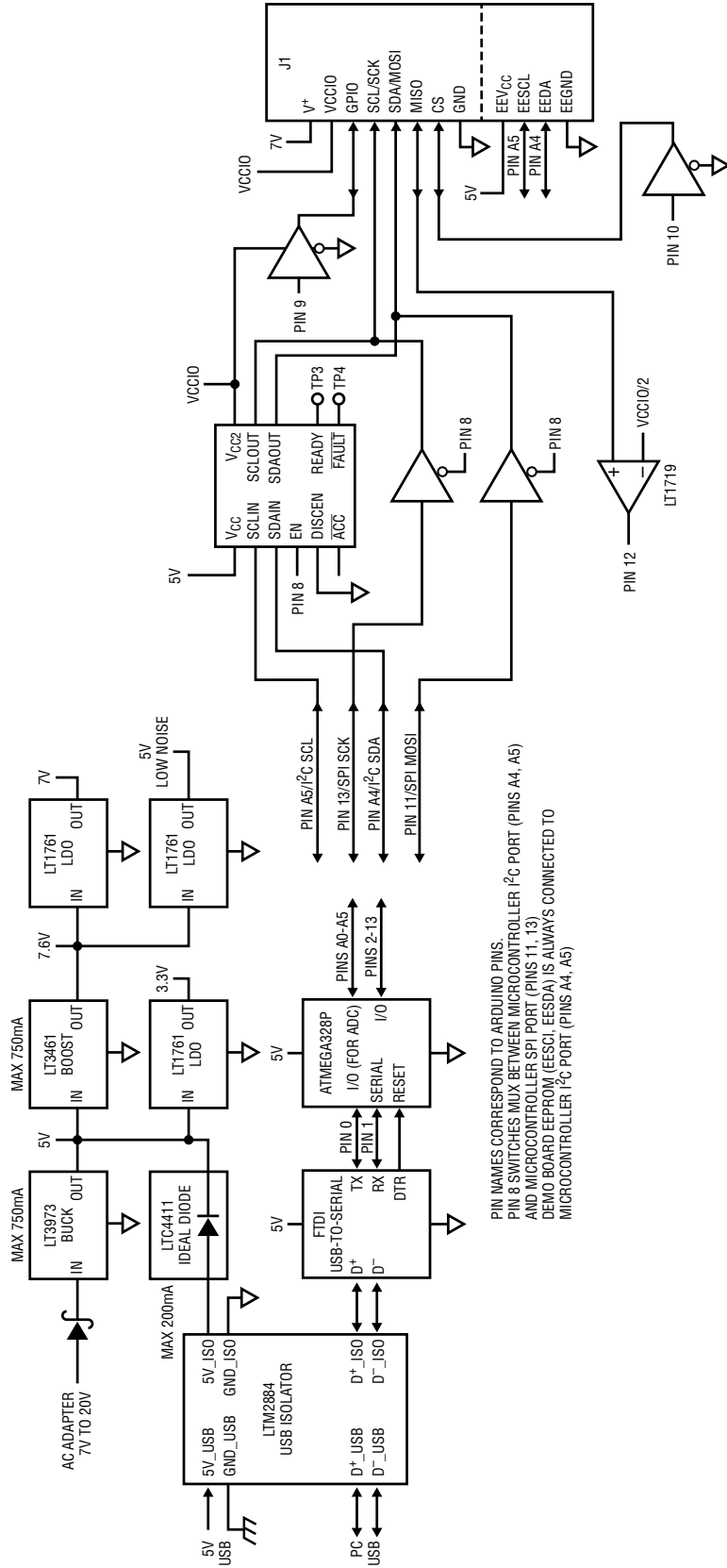

DC2026C BD

PARTS LIST

ITEM	QTY	REFERENCE	PART DESCRIPTION	MANUFACTURER/PART NUMBER
1	2	C1, C7	CAP., X5R, 4.7µF, 16V, 10%, 0603	TDK, C1608X5R1C475K080AC
2	2	C2, C14	CAP., X7R, 0.01µF, 16V, 10%, 0603	AVX, 0603YC103KAT2A
3	4	C3, C9, C12, C15	CAP., X5R, 10µF, 16V, 10%, 0805	MURATA, GRM21BR61C106KE15L
4	5	C4, C13, C17, C18, C23	CAP., X7R, 1µF, 16V, 10%, 0603	TDK, C1608X7R1C105K080AC
5	1	C5	CAP., NPO, 15pF, 50V, 10%, 0603	AVX, 06035A150KAT2A
6	1	C6	CAP., X5R, 4.7µF, 25V, 10%, 0805	TDK, C2012X5R1E475K125AB
7	10	C8, C19-C22, C25, C28, C32-C34	CAP., X7R, 0.1µF, 16V, 10%, 0603	AVX, 0603YC104KAT2A
8	1	C10	CAP., COG, 10pF, 25V, 10%, 0402	AVX, 04023A100KAT2A
9	1	C11	CAP., X5R, 22µF, 6.3V, 20%, 1206	TAIYO YUDEN, JMK316ABJ226MLHT
10	1	C16	CAP., X7R, 2.2µF, 50V, 10%, 1206	MURATA, GRM31CR71H225KA88L
11	1	C24	CAP., X7R, 0.047µF, 16V, 10%, 0603	AVX, 0603YC473KAT2A
12	1	C26	CAP., ALUM., 10µF, 50V, 10%, SMT	SUN ELECT., 50CE10BSS
13	1	C27	CAP., X5R, 0.22µF, 10V, 20%, 0402	AVX, 0402ZD224MAT2A
14	0	C29	CAP., OPT, 0805	OPTION
15	2	C30, C31	CAP., X7R, 2.2nF, 1kV, 10%, 1206	AVX, 1206AC222KAT1A
16	3	D1, D4, D5	LED, YELLOW, DIFFUSED, 0805	AVAGO, HSMY-C170
17	1	D2	LED, GREEN, DIFFUSED, 0805	AVAGO, HSMG-C170
18	1	D3	DIODE, SCHOTTKY, 100V, 2A, SMB	DIODES INC., B2100-13-F
19	1	JP3	HEADER, 2x4 PIN, 0.079CC	SULLINS, NRPN042PAEN-RC
20	1	J1	HEADER, 2x7 DUAL ROW	MOLEX, 87831-1420
21	1	J2	CONNECTOR, POWER JACK, 2.1mm	CUI INC., PJ-002AH
22	2	J3, J8	CONN., RECEPT., 0.100, 8 POSITION	SULLINS, PPPC081LFBN-RC
23	1	J4	HEADER, 2x3 PIN, 0.100	SAMTEC, TSW-103-07-L-D
24	1	J5	CONNECTOR, USB TYPE B, RIGHT ANGLE PCB MOUNT	FCI, 61729-0010BLF
25	1	J6	CONN., RECEPT., 0.100, 10 POSITION	SULLINS, PPPC101LFBN-RC
26	1	J7	CONN., RECEPT., 0.100, 6 POSITION	SULLINS, PPPC061LFBN-RC
27	1	L1	INDUCTOR, 15µH, 1.3A, SMD	COOPER, MPI4040R3-150-R
28	1	L2	INDUCTOR, SHIELDED POWER, 10µH, SMT	COILCRAFT, XFL3010-103ME
29	4	MP1-MP4	BUMPER, ADHESIVE-BACKED	3M, SJ5376
30	1	Q1	TRANSISTOR, MOSFET, N-CH 60V, 150mA, SOT-23	DIODES INC., VN10LFTA
31	1	R1	RES., CHIP, 64.9k, 1/10W, 1% 0603	VISHAY, CRCW060364K9FKEA
32	1	R2	RES., CHIP, 47.5k, 1/10W, 1% 0603	VISHAY, CRCW060347K5FKEA
33	1	R3	RES., CHIP, 215k, 1/10W, 1% 0603	VISHAY, CRCW0603215KFKEA
34	1	R4	RES., CHIP, 13.7k, 1/10W, 1% 0603	VISHAY, CRCW060313K7FKEA
35	1	R5	RES., CHIP, 42.2k, 1/10W, 1% 0603	VISHAY, CRCW060342K2FKEA
36	4	R6, R7, R9, R10	RES., CHIP, 4.99k, 1/10W, 1% 0603	VISHAY, CRCW06034K99FKEA
37	6	R8, R25, R48, R52, R53, R54	RES., CHIP, 49.9k, 1/10W, 1% 0603	VISHAY, CRCW060349K9FKEA
38	0	R11, R32	RES., CHIP, OPT, 0805	OPTION
39	14	R12, R13, R15, R17, R20, R21, R22, R23, R24, R35, R36, R42, R44, R46	RES., CHIP, 1k, 1/10W, 1% 0603	VISHAY, CRCW06031K00FKEA

DEMO MANUAL DC2026C

PARTS LIST

ITEM	QTY	REFERENCE	PART DESCRIPTION	MANUFACTURER/PART NUMBER
40	1	R14	RES., CHIP, 1MEG, 1/16W, 1%, 0402	VISHAY, CRCW04021M00FKED
41	1	R16	RES., CHIP, 1MEG, 1/10W, 1%, 0603	VISHAY, CRCW06031M00FKEA
42	5	R18, R40, R41, R45, R47	RES., CHIP, 10k, 1/10W, 1%, 0603	VISHAY, CRCW060310K0FKEA
43	1	R19	RES., CHIP, 86.6k, 1/10W, 1%, 0603	NIC, NRC06F8662TRF
44	5	R25, R48, R52, R53, R54	RES., CHIP, 49.9k, 1/10W, 1%, 0603	VISHAY, CRCW060349K9FKEA, NIC, NRC06F4992TRF
45	1	R26	RES., CHIP, 0.20Ω, 1/4W, 5%, 0805	PANASONIC, ERJ-S6SJR20V
46	1	R27	RES., CHIP, 107k, 1/16W, 1%, 0402	VISHAY, CRCW0402107KFKED
47	1	R28	RES., CHIP, 475k, 1/16W, 1%, 0402	VISHAY, CRCW0402475KFKED
48	1	R29	RES., CHIP, 215k, 1/16W, 1%, 0402	VISHAY, CRCW0402215KFKED
49	1	R30	RES., CHIP, 316k, 1/16W, 1%, 0402	VISHAY, CRCW0402316KFKED
50	1	R31	RES., CHIP, 100Ω, 1/10W, 5%, 0603	VISHAY, CRCW0603100RJNEA
51	0	R33, R34, R37, R38, R43	RES., CHIP, OPT, 0603	OPTION
52	1	R39	RES., CHIP, 0Ω, 1/10W, 0603	VISHAY, CRCW06030000Z0EA
53	1	R49	RES., CHIP, 105k, 1/10W, 1%, 0603	VISHAY, CRCW0603105KFKEA
54	1	R50	RES., CHIP, 19.1k, 1/10W, 1%, 0603	VISHAY, CRCW060319K1FKEA
55	1	R51	RES., CHIP, 40.2k, 1/10W, 1%, 0603	VISHAY, CRCW060340K2FKEA
56	2	R55, R56	RES., 49.9Ω, 1/10W, 1%, 0603	NIC, NRC06F49R9TRF
57	1	R57	RES., 24.9Ω, 1/10W, 1%, 0603	NIC, NRC06F24R9TRF
58	1	S1	SWITCH, PUSHBUTTON, MINIATURE	WÜRTH ELEKTRONIK, 434111025826
59	1	U1	MODULE, USB TRANSCEIVER, BGA-44	LINEAR TECH., LTM2884CY#PBF
60	1	U2	IC, DC-DC CONVERTER, TSOT-23	LINEAR TECH., LT3461ES6#PBF
61	1	U3	IC, LDO MICROPOWER REGULATOR, ADJUSTABLE, TSOT-23	LINEAR TECH., LT1761ES5-SD#PBF
62	1	U4	IC, BUS BUFFER, 2-WIRE, MSOP	LINEAR TECH., LTC4315CMS#PBF
63	1	U5	IC, LDO MICROPOWER REGULATOR, 3.3V, TSOT-23	LINEAR TECH., LT1761ES5-3.3#PBF
64	1	U6	IC, IDEAL DIODE, LOW LOSS, TSOT-23	LINEAR TECH., LTC4411ES5#PBF
65	1	U7	IC, MICROCONTROLLER	ATMEL, ATMEGA328P-AU
66	1	U8	IC, LDO MICROPOWER REGULATOR, ADJUSTABLE, TSOT-23	LINEAR TECH., LT1761ES5-BYP#PBF
67	1	U9	IC, USB UART, 28-SSOP	FTDI, FT232RL-REEL
68	1	U10	IC, STEP-DOWN REGULATOR, MS10	LINEAR TECH., LT3973EMSE#PBF
69	1	U11	IC., SINGLE/DUAL-SUPPLY COMPARATOR	LINEAR TECH., LT1719CS6#PBF
70	2	U12, U13	IC, TRI-STATE UHS BUFFER, US8	FAIRCHILD, NC7WZ125K8X
71	1	XJP3	SHUNT, 2mm	SAMTEC, 2SN-BK-G
72	1	Y1	RESONATOR, 16MHz, SMT	MURATA, CSTCE16M0V53-R0

SCHEMATIC DIAGRAM

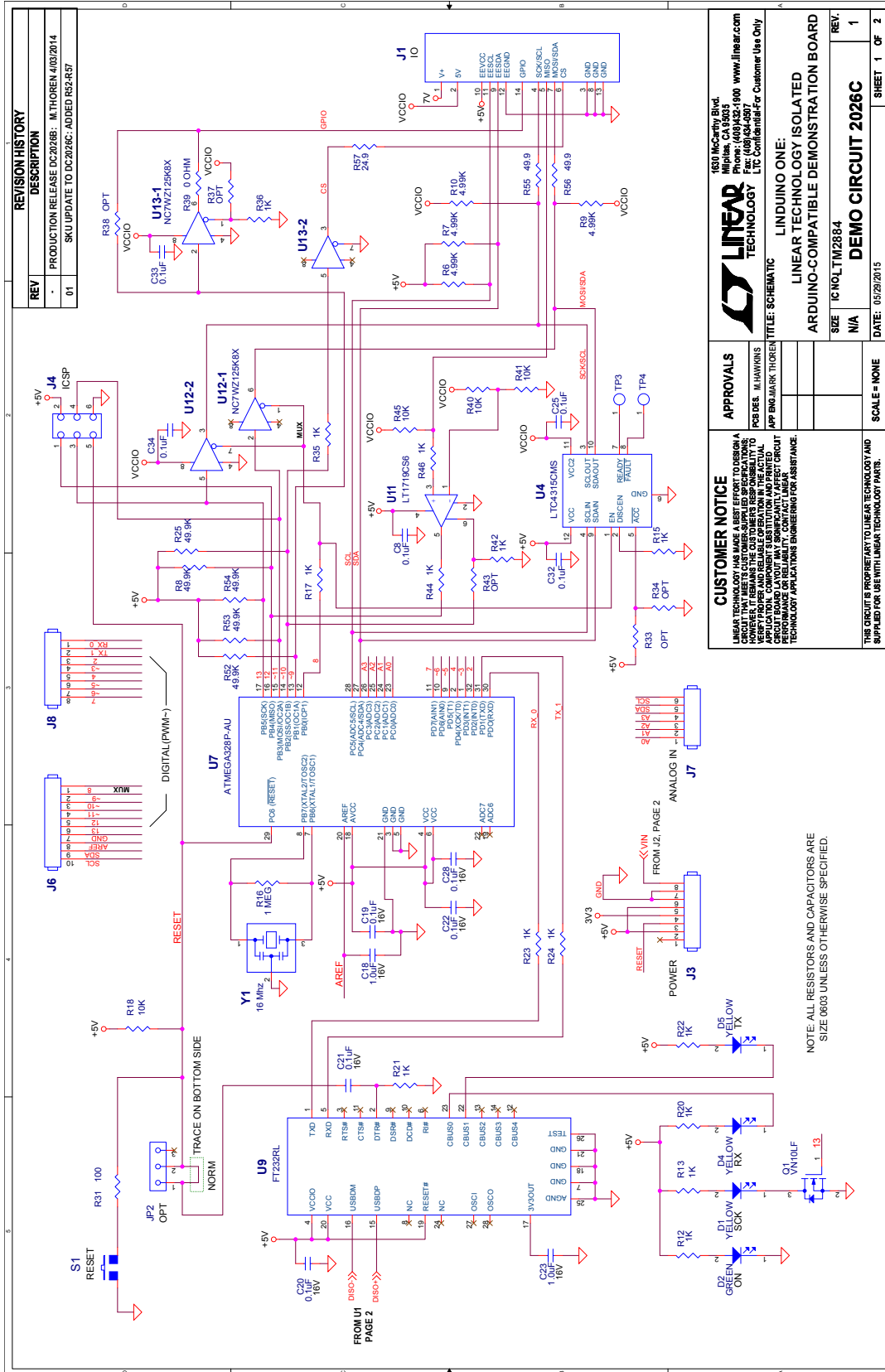

REVISION HISTORY (Revision history begins at Rev C of Manual)

BOARD REV	DATE	DESCRIPTION	PAGE NUMBER
B	08/14	Added circuitry to allow adjustment of VCCIO voltage and SPI/I ² C logic levels	11, 12
C	06/15	Revised Board to C, added pull-up resistors to U12, U13 inputs. Added source termination resistors to U1, U13 outputs.	13, 14, 15
C	03/16	Update text, screenshots to show Arduino 1.6.4	2, 4, 5, 8, 9

DEMO MANUAL DC2026C

DEMONSTRATION BOARD IMPORTANT NOTICE

Linear Technology Corporation (LTC) provides the enclosed product(s) under the following **AS IS** conditions:

This demonstration board (DEMO BOARD) kit being sold or provided by Linear Technology is intended for use for **ENGINEERING DEVELOPMENT OR EVALUATION PURPOSES ONLY** and is not provided by LTC for commercial use. As such, the DEMO BOARD herein may not be complete in terms of required design-, marketing-, and/or manufacturing-related protective considerations, including but not limited to product safety measures typically found in finished commercial goods. As a prototype, this product does not fall within the scope of the European Union directive on electromagnetic compatibility and therefore may or may not meet the technical requirements of the directive, or other regulations.

If this evaluation kit does not meet the specifications recited in the DEMO BOARD manual the kit may be returned within 30 days from the date of delivery for a full refund. **THE FOREGOING WARRANTY IS THE EXCLUSIVE WARRANTY MADE BY THE SELLER TO BUYER AND IS IN LIEU OF ALL OTHER WARRANTIES, EXPRESSED, IMPLIED, OR STATUTORY, INCLUDING ANY WARRANTY OF MERCHANTABILITY OR FITNESS FOR ANY PARTICULAR PURPOSE. EXCEPT TO THE EXTENT OF THIS INDEMNITY, NEITHER PARTY SHALL BE LIABLE TO THE OTHER FOR ANY INDIRECT, SPECIAL, INCIDENTAL, OR CONSEQUENTIAL DAMAGES.**

The user assumes all responsibility and liability for proper and safe handling of the goods. Further, the user releases LTC from all claims arising from the handling or use of the goods. Due to the open construction of the product, it is the user's responsibility to take any and all appropriate precautions with regard to electrostatic discharge. Also be aware that the products herein may not be regulatory compliant or agency certified (FCC, UL, CE, etc.).

No License is granted under any patent right or other intellectual property whatsoever. **LTC assumes no liability for applications assistance, customer product design, software performance, or infringement of patents or any other intellectual property rights of any kind.**

LTC currently services a variety of customers for products around the world, and therefore this transaction **is not exclusive**.

Please read the DEMO BOARD manual prior to handling the product. Persons handling this product must have electronics training and observe good laboratory practice standards. **Common sense is encouraged.**

This notice contains important safety information about temperatures and voltages. For further safety concerns, please contact a LTC application engineer.

Mailing Address:

Linear Technology
1630 McCarthy Blvd.
Milpitas, CA 95035

Copyright © 2004, Linear Technology Corporation

Looking for pricing, stock, or lifecycle information?

Click below to explore more details on WIN SOURCE:

- ⊖ [View LTC2943IDD#TRPBF on WIN SOURCE](#)
- ⊖ [Linear Technology Information](#)

Optimize Your Supply Chain with WIN SOURCE Solutions

- ✓ Global Sourcing Solution
- ✓ Obsolete Management
- ✓ Cost Control Management
- ✓ Shortage Management
- ✓ Alternative Solution
- ✓ Excess Inventory Management