



**THE DATASHEET OF
XR3172EID-F**



GENERAL DESCRIPTION

The **XR3170E - XR3178E** family of RS-485 devices are designed for reliable, bidirectional communication on multipoint bus transmission lines. Each device contains one differential driver and one differential receiver. **XR3172E**, **XR3175E** and **XR3178E** are half-duplex devices; other part numbers are full-duplex. All devices comply with TIA/EIA-485 and TIA/EIA-422 standards. Lead free and RoHS compliant packages are available for all models.

These devices are ruggedized for use in harsh operating conditions over the entire common-mode voltage range from -7V to +12V. Receivers are specially designed to fail-safe to a logic high output state if the inputs are left un-driven or shorted. All RS-485 bus pins are protected against severe ESD events up to +/-15kV (Air-Gap and Human Body Model) and up to +/-8kV Contact Discharge (IEC 61000-4-2). Drivers are protected from excess current flow caused by bus contention or output short-circuits by both an internal current limit and a thermal-overload shutdown. Devices are rated for Industrial (-40 to +85°C) operating temperatures. Receivers have exceptionally high input impedance, which places only 1/8th the standard load on a shared bus. Up to 256 transceivers may coexist while preserving full signal margin.

All devices operate from a single 3.3V power supply and draw negligible quiescent power. All versions except the XR3171E, XR3174E and XR3177E may independently enable and disable their driver and receiver and enter a low power shutdown mode if both driver and receiver are disabled. All outputs maintain high impedance in shutdown or when powered off.

FEATURES

- 3.3V Single Supply Operation
- High Speed 20Mbps Data Rate
- Slew Rate Limited - 250kbps And 500kbps Data Rate
- 1/8th Unit Load, 256 Transceivers On Bus
- Enhanced Failsafe For Receiver - Open, Short Or Terminated Lines
- Robust ESD Protection For RS-485 Pins
 - +/-15kV Air-Gap Discharge
 - +/-15kV Human Body Model
 - +/-8kV Contact Discharge
- Hot Swap Glitch Protection
- Driver Short Circuit Current Limit And Thermal Shutdown For Overload Protection
- Ultra-Low 650uA Quiescent Current
- 1µA Shutdown Mode
- Industry Standard Package Footprints

TYPICAL APPLICATIONS

- Motor Control
- Building Automation
- Security Systems
- Remote Utility Meter Reading
- Long Or Un-Terminated Transmission Lines

FIGURE 1. TYPICAL APPLICATION CIRCUIT

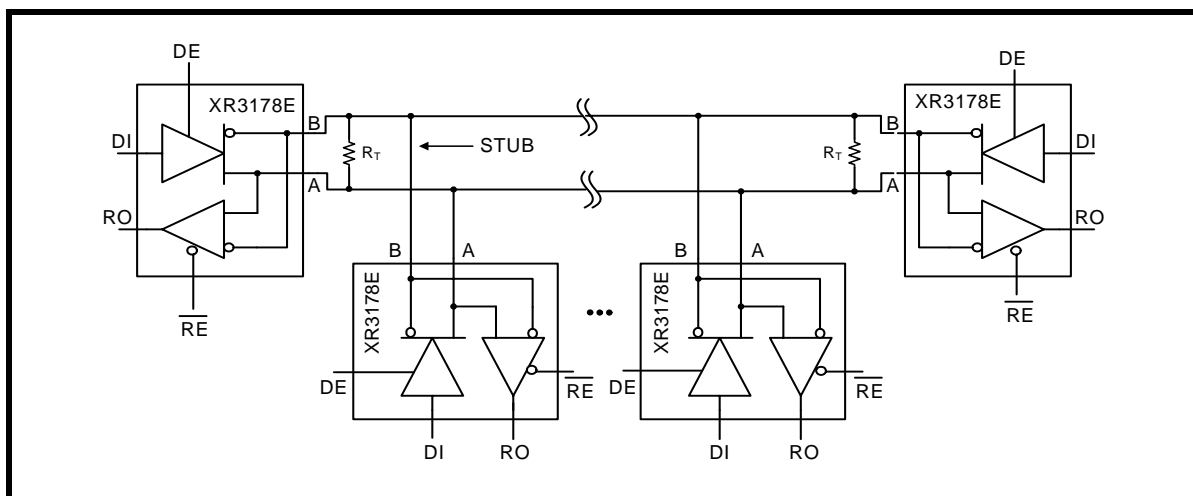
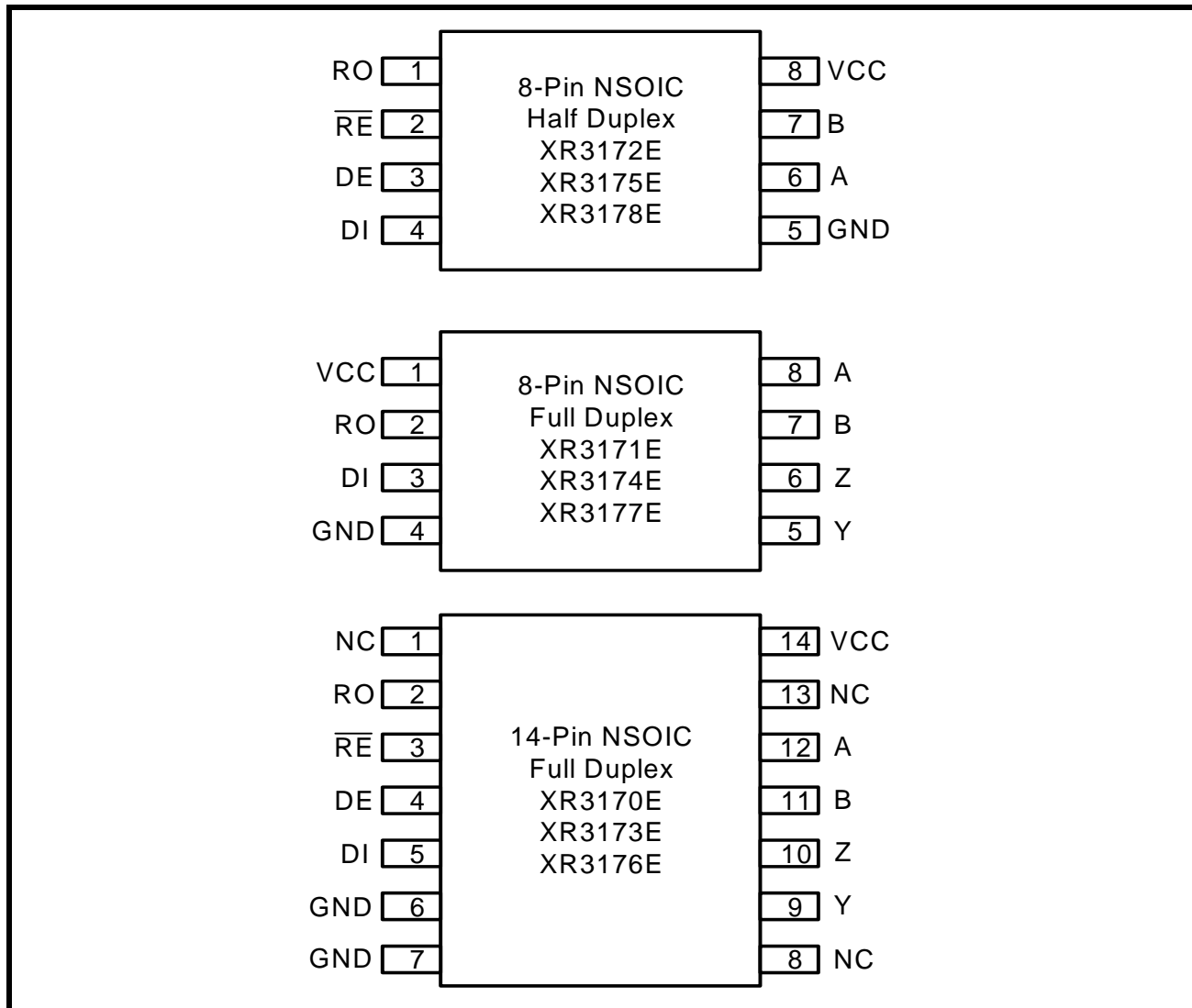

FIGURE 2. PIN OUT ASSIGNMENT



ORDERING INFORMATION

PART NUMBER	PACKAGE	OPERATING TEMPERATURE RANGE	DEVICE STATUS
XR3170EID	14-pin Narrow SOIC	-40°C to +85°C	Active
XR3171EID	8-pin Narrow SOIC	-40°C to +85°C	Active
XR3172EID	8-pin Narrow SOIC	-40°C to +85°C	Active
XR3173EID	14-pin Narrow SOIC	-40°C to +85°C	Active
XR3174EID	8-pin Narrow SOIC	-40°C to +85°C	Active
XR3175EID	8-pin Narrow SOIC	-40°C to +85°C	Active
XR3176EID	14-pin Narrow SOIC	-40°C to +85°C	Active
XR3177EID	8-pin Narrow SOIC	-40°C to +85°C	Active
XR3178EID	8-pin Narrow SOIC	-40°C to +85°C	Active

Note: Please visit www.exar.com for tape and reel option part numbers.



PIN DESCRIPTIONS

Pin Assignments

PIN NUMBER			PIN NAME	TYPE	DESCRIPTION
HALF DUPLEX	FULL DUPLEX				
XR3172E XR3175E XR3178E	XR3171E XR3174E XR3177E	XR3170E XR3173E XR3176E			
1	2	2	RO	O	Receiver Output. When \overline{RE} is low and if (A-B) \geq -50mV, RO is High. If (A-B) \leq -200mV, RO is Low.
2	-	3	\overline{RE}	I	Receiver Output Enable. When \overline{RE} is Low, RO is enabled. When \overline{RE} is High, RO is high impedance. \overline{RE} should be High and DE should be low to enter shutdown mode. \overline{RE} is a hot-swap input.
3	-	4	DE	I	Driver Output Enable. When DE is High, outputs are enabled. When DE is low, outputs are high impedance. DE should be low and \overline{RE} should be High to enter shutdown mode. DE is a hot-swap input.
4	3	5	DI	I	Driver Input. With DE high, a low level on DI forces Non-Inverting output low and inverting output high. Similarly, a high level on DI forces Non-Inverting output High and Inverting output Low.
5	4	6, 7	GND	Pwr	Ground.
6	-	-	A	I/O	Non-Inverting Receiver Input and Non-Inverting Driver Output.
7	-	-	B	I/O	Inverting Receiver Input and Inverting Driver Output.
8	1	14	Vcc	Pwr	+3.3V power supply input. Bypass with 0.1uF capacitor.
-	8	12	A	I	Non-Inverting Receiver Input.
-	7	11	B	I	Inverting Receiver Input.
-	5	9	Y	O	Non-Inverting Driver Output.
-	6	10	Z	O	Inverting Driver Output.
-	-	1, 8, 13	NC	-	No Connect, not internally connected.

Pin type: I=Input, O=Output.

ABSOLUTE MAXIMUM RATINGS

These are stress ratings only and functional operation of the device at these ratings or any other above those indicated in the operation sections to the specifications below is not implied. Exposure to absolute maximum rating conditions for extended periods of time may affect reliability and cause permanent damage to the device.

V_{CC}	+6.0V
Input Voltage at control pins (\overline{RE} , DE and DI)	-0.3V to ($V_{CC} + 0.3V$)
Driver Output Voltage (A, B, Y and Z)	-8V to +13V
Receiver Output Voltage (RO)	-0.3V to ($V_{CC} + 0.3V$)
Receiver Input Voltage (A and B)	-8V to +13V
Storage Temperature Range	-65°C to + 150°C
Lead Temperature (soldering, 10s)	+300°C
Package Power Dissipation Maximum Junction Temperature 150°C 8-Pin SO $\theta_{JA} = 128.4^{\circ}C/W$ 14-Pin SO $\theta_{JA} = 86^{\circ}C/W$	

CAUTION:

ESD (Electrostatic Discharge) sensitive device. Permanent damage may occur on unconnected devices subject to high energy electrostatic fields. Unused devices must be stored in conductive foam or shunts. Personnel should be properly grounded prior to handling this device. The protective foam should be discharged to the destination socket before devices are removed.

ELECTRICAL CHARACTERISTICS

UNLESS OTHERWISE NOTED: $V_{CC} = +3.0V$ TO $+3.6V$ WITH T_A FROM $-40^{\circ}C$ TO $+85^{\circ}C$. TYPICAL VALUES ARE AT $V_{CC} = +3.3V$ AND $25^{\circ}C$.

SYMBOL	PARAMETERS	MIN.	TYP.	MAX.	UNITS	CONDITIONS
DRIVER DC CHARACTERISTICS						
V_{OD}	Differential Driver Output			V_{CC}	V	No Load
		2.0	2.65			$R_L = 100\Omega$ (RS-422), Figure 3
		1.7	2.35			$R_L = 54\Omega$ (RS-485), Figure 3
		1.7	2.35			$V_{CM} = -7V$, Figure 4
		1.7	2.35			$V_{CM} = +12V$, Figure 4
ΔV_{OD}	Change in Magnitude of Differential Output	-0.20		0.20	V	$R_L = 100\Omega$ (RS-422), Figure 3, See Note 1
		-0.20		0.20		$R_L = 54\Omega$ (RS-485), Figure 3, See Note 1
		-0.20		0.20		$V_{CM} = -7V$, Figure 4, See Note 1
		-0.20		0.20		$V_{CM} = +12V$, Figure 4, See Note 1
V_{OC}	Driver Common Mode Output Voltage steady state			3.0	V	Figure 3



UNLESS OTHERWISE NOTED: VCC = +3.0V TO +3.6V WITH T_A FROM -40°C TO +85°C. TYPICAL VALUES ARE AT VCC = +3.3V AND 25°C.

SYMBOL	PARAMETERS	MIN.	TYP.	MAX.	UNITS	CONDITIONS
ΔV_{OC}	Change in Magnitude of Common Mode Output Voltage	-0.2		0.2	V	Figure 3, See Note 1
I_{OSD}	Driver Short Circuit Current Limit	-250		250	mA	-7V ≤ V _{OUT} ≤ 12V, Figure 5
V_{IH}	Logic Input Thresholds (DI, DE, \overline{RE})	2.0			V	Logic Input High
V_{IL}				0.8	V	Logic Input Low
V_{HYS}	Driver Input Hysteresis		100		mV	T _A = 25°C
I_{IN}	Logic Input Current (DI, DE and \overline{RE})	-1		1	μA	0V ≤ I _N ≤ +V _{CC} , after first transition, Note 2
I_{OL}	Output Leakage Current (Full-Duplex versions, Y and Z pins) Note 2			125	μA	V _{out} = 12V, DE = 0V, \overline{RE} = 0V, V _{CC} = 0V or 3.3V.
		-100			μA	V _{out} = -7V, DE = 0V, \overline{RE} = 0V, V _{CC} = 0V or 3.3V.
RECEIVER DC CHARACTERISTICS						
R_{IN}	Receiver Input Resistance	96	160		KΩ	-7V ≤ V _{CM} ≤ 12V
I_{IN}	Input Current (A, B pins)		70	125	μA	DE = 0V, V _{CC} = 0V or 3.3V, V _{IN} = 12V
		-100	-55		μA	DE = 0V, V _{CC} = 0V or 3.3V, V _{IN} = -7V
V_{IH}, V_{IL}	Receiver Differential Thresholds (V _A - V _B)	-200	-120	-50	mV	-7V ≤ V _{CM} ≤ 12V
	Receiver Input Hysteresis		25		mV	V _{CM} = 0V
V_{OH}	Receiver Output Voltage High	V _{CC} - 0.6			V	I _{OUT} = -8mA, V _{ID} = -50mV
V_{OL}	Receiver Output Voltage Low			0.4	V	I _{OUT} = 8mA, V _{ID} = -200mV
I_{OZ}	High-Z Receiver Output Current		+/- 0.03	+/-1.0	μA	V _{CC} = 3.3V, 0.40V ≤ V _{out} ≤ 2.4V
I_{OSC}	Receiver Output Short Circuit Current			+/-95	mA	0V ≤ V _{RO} ≤ V _{CC}
SUPPLY AND PROTECTION						
I_{CC1}	Supply Current - Driver Enabled		650	950	μA	No Load, DE = V _{CC} , DI = 0V or V _{CC}
I_{CC2}	Supply Current - Shutdown Mode			1	μA	DE = 0V, \overline{RE} = V _{CC} , DI = 0V or V _{CC}
T_{SD}	Thermal Shutdown Temperature		165		°C	Junction temperature, Note 4
	Thermal Shutdown Hysteresis		15		°C	Note 4
XR3170E, XR3171E, XR3172E						
DRIVER AC CHARACTERISTICS						
freq	Max. Data Signaling Rate	250			kbps	1/t _{UI} , Duty Cycle 40 to 60%

UNLESS OTHERWISE NOTED: $V_{CC} = +3.0V$ TO $+3.6V$ WITH T_A FROM $-40^{\circ}C$ TO $+85^{\circ}C$. TYPICAL VALUES ARE AT $V_{CC} = +3.3V$ AND $25^{\circ}C$.

SYMBOL	PARAMETERS	MIN.	TYP.	MAX.	UNITS	CONDITIONS
t_{PLH}	Driver Propagation Delay (Low to High)	250		1500	ns	$C_L = 50pF$, $R_L = 54\Omega$, Figures 6 and 7
t_{PHL}	Driver Propagation Delay (High to Low)	250		1500	ns	$C_L = 50pF$, $R_L = 54\Omega$, Figures 6 and 7
t_R	Driver Rise Time	350		1600	ns	$C_L = 50pF$, $R_L = 54\Omega$, Figures 6 and 7
t_F	Driver Fall Time	350		1600	ns	$C_L = 50pF$, $R_L = 54\Omega$, Figures 6 and 7
$ t_{PLH}-t_{PHL} $	Differential Pulse Skew			200	ns	Figures 6 and 7
t_{ZH}	Driver Enable to Output High			2500	ns	$C_L = 50pF$, $R_L = 500\Omega$, Figures 8 and 9
t_{ZL}	Driver Enable to Output Low			2500	ns	$C_L = 50pF$, $R_L = 500\Omega$, Figures 10 and 11
t_{HZ}	Driver Disable from Output High			150	ns	$C_L = 50pF$, $R_L = 500\Omega$, Figures 8 and 9
t_{LZ}	Driver Disable from Output Low			150	ns	$C_L = 50pF$, $R_L = 500\Omega$, Figures 10 and 11
t_{OZV}	Shutdown to Driver Output Valid			3500	ns	$C_L = 50pF$, $R_L = 500\Omega$
t_{SHDN}	Time to Shutdown	50	200	600	ns	Notes 3 and 4
RECEIVER AC CHARACTERISTICS						
freq	Data Signaling Rate	250			kbps	$1/t_{UI}$, Duty Cycle 40 to 60%
t_{PLH}	Receiver Propagation Delay (Low to High)			200	ns	$V_{ID} = +/-2V$, $C_L = 15pF$, Figures 12 and 13
t_{PHL}	Receiver Propagation Delay (High to Low)			200	ns	$V_{ID} = +/-2V$, $C_L = 15pF$, Figures 12 and 13
skew	Receiver Propagation Delay Skew			30	ns	$V_{ID} = +/-2V$, $C_L = 15pF$, Figures 12 and 13 $skew = t_{PLH}-t_{PHL} $
t_R	Receiver Output Rise Time		3	6	ns	$C_L = 15pF$, Figure 12
t_F	Receiver Output Fall Time		3	6	ns	$C_L = 15pF$, Figure 12
t_{ZH}	Receiver Enable to Output High			50	ns	$C_L = 15pF$, Figure 14
t_{ZL}	Receiver Enable to Output Low			50	ns	$C_L = 15pF$, Figure 14
t_{HZ}	Receiver Disable from Output High			50	ns	$C_L = 15pF$, Figure 14
t_{LZ}	Receiver Disable from Output Low			50	ns	$C_L = 15pF$, Figure 14
$t_{ZH(SHDN)}$	Shutdown to Receiver Output Valid High			3500	ns	$C_L = 15pF$, Figure 14
$t_{ZL(SHDN)}$	Shutdown to Receiver Output Valid Low			3500	ns	$C_L = 15pF$, Figure 14



UNLESS OTHERWISE NOTED: VCC = +3.0V TO +3.6V WITH T_A FROM -40°C TO +85°C. TYPICAL VALUES ARE AT VCC = +3.3V AND 25°C.

SYMBOL	PARAMETERS	MIN.	TYP.	MAX.	UNITS	CONDITIONS
t _{SHDN}	Time to Shutdown	50	200	600	ns	Notes 3 and 4
XR3173E, XR3174E and XR3175E						
DRIVER AC CHARACTERISTICS						
freq	Max. Data Signaling Rate	500			kbps	1/t _{UI} , Duty Cycle 40 to 60%
t _{PLH}	Driver Propagation Delay (Low to High)	180		800	ns	C _L = 50pF, R _L = 54Ω, Figures 6 and 7
t _{PHL}	Driver Propagation Delay (High to Low)	180		800	ns	C _L = 50pF, R _L = 54Ω, Figures 6 and 7
t _R	Driver Rise Time	200		800	ns	C _L = 50pF, R _L = 54Ω, Figures 6 and 7
t _F	Driver Fall Time	200		800	ns	C _L = 50pF, R _L = 54Ω, Figures 6 and 7
t _{PLH} -t _{PHL}	Differential Pulse Skew			100	ns	Figures 6 and 7
t _{ZH}	Driver Enable to Output High			2500	ns	C _L = 50pF, R _L = 500Ω, Figures 8 and 9
t _{ZL}	Driver Enable to Output Low			2500	ns	C _L = 50pF, R _L = 500Ω, Figures 10 and 11
t _{HZ}	Driver Disable from Output High			150	ns	C _L = 50pF, R _L = 500Ω, Figures 8 and 9
t _{LZ}	Driver Disable from Output Low			150	ns	C _L = 50pF, R _L = 500Ω, Figures 10 and 11
t _{OZV}	Shutdown to Driver Output Valid			3500	ns	C _L = 50pF, R _L = 500Ω
t _{SHDN}	Time to Shutdown	50	200	600	ns	Notes 3 and 4
RECEIVER AC CHARACTERISTICS						
freq	Data Signaling Rate	500			kbps	1/t _{UI} , Duty Cycle 40 to 60%
t _{PLH}	Receiver Propagation Delay (Low to High)			200	ns	V _{ID} = +/-2V, C _L = 15pF, Figures 12 and 13
t _{PHL}	Receiver Propagation Delay (High to Low)			200	ns	V _{ID} = +/-2V, C _L = 15pF, Figures 12 and 13
skew	Receiver Propagation Delay Skew			30	ns	V _{ID} = +/-2V, C _L = 15pF, Figures 12 and 13 skew = t _{PLH} -t _{PHL}
t _R	Receiver Output Rise Time		3	6	ns	C _L = 15pF
t _F	Receiver Output Fall Time		3	6	ns	C _L = 15pF
t _{ZH}	Receiver Enable to Output High			50	ns	C _L = 15pF, Figure 14
t _{ZL}	Receiver Enable to Output Low			50	ns	C _L = 15pF, Figure 14
t _{HZ}	Receiver Disable from Output High			50	ns	C _L = 15pF, Figure 14

UNLESS OTHERWISE NOTED: $V_{CC} = +3.0V$ TO $+3.6V$ WITH T_A FROM $-40^{\circ}C$ TO $+85^{\circ}C$. TYPICAL VALUES ARE AT $V_{CC} = +3.3V$ AND $25^{\circ}C$.

SYMBOL	PARAMETERS	MIN.	TYP.	MAX.	UNITS	CONDITIONS
t_{LZ}	Receiver Disable from Output Low			50	ns	$C_L = 15pF$, Figure 14
$t_{ZH(SHDN)}$	Shutdown to Receiver Output Valid High			3500	ns	$C_L = 15pF$, Figure 14
$t_{ZL(SHDN)}$	Shutdown to Receiver Output Valid Low			3500	ns	$C_L = 15pF$, Figure 14
t_{SHDN}	Time to Shutdown	50	200	600	ns	Notes 3 and 4
XR3176E, XR3177E and XR3178E						
DRIVER AC CHARACTERISTICS						
freq	Max. Data Signaling Rate	20			Mbps	$1/t_{UI}$, Duty Cycle 40 to 60%
t_{PLH}	Driver Propagation Delay (Low to High)	4	12	40	ns	$C_L = 50pF$, $R_L = 54\Omega$, Figures 6 and 7
t_{PHL}	Driver Propagation Delay (High to Low)	4	12	40	ns	$C_L = 50pF$, $R_L = 54\Omega$, Figures 6 and 7
t_R	Driver Rise Time	2	3	10	ns	$C_L = 50pF$, $R_L = 54\Omega$, Figures 6 and 7
t_F	Driver Fall Time	2	3	10	ns	$C_L = 50pF$, $R_L = 54\Omega$, Figures 6 and 7
$ t_{PLH}-t_{PHL} $	Differential Pulse Skew			5	ns	Figures 6 and 7
t_{ZH}	Driver Enable to Output High			150	ns	$C_L = 50pF$, $R_L = 500\Omega$, Figures 8 and 9
t_{ZL}	Driver Enable to Output Low			150	ns	$C_L = 50pF$, $R_L = 500\Omega$, Figures 10 and 11
t_{HZ}	Driver Disable from Output High			150	ns	$C_L = 50pF$, $R_L = 500\Omega$, Figures 8 and 9
t_{LZ}	Driver Disable from Output Low			150	ns	$C_L = 50pF$, $R_L = 500\Omega$, Figures 10 and 11
t_{OZV}	Shutdown to Driver Output Valid			3500	ns	$C_L = 50pF$, $R_L = 500\Omega$
t_{SHDN}	Time to Shutdown	50	200	600	ns	Notes 3 and 4
RECEIVER AC CHARACTERISTICS						
freq	Data Signaling Rate	20			Mbps	$1/t_{UI}$, Duty Cycle 40 to 60%
t_{PLH}	Receiver Propagation Delay (Low to High)	4	22	40	ns	$V_{ID} = +/-2V$, $C_L = 15pF$, Figures 12 and 13
t_{PHL}	Receiver Propagation Delay (High to Low)	4	22	40	ns	$V_{ID} = +/-2V$, $C_L = 15pF$, Figures 12 and 13
skew	Receiver Propagation Delay Skew			5	ns	$V_{ID} = +/-2V$, $C_L = 15pF$, Figures 12 and 13 skew = $ t_{PLH}-t_{PHL} $
t_R	Receiver Output Rise Time		3	6	ns	$C_L = 15pF$



UNLESS OTHERWISE NOTED: $V_{CC} = +3.0V$ TO $+3.6V$ WITH T_A FROM $-40^{\circ}C$ TO $+85^{\circ}C$. TYPICAL VALUES ARE AT $V_{CC} = +3.3V$ AND $25^{\circ}C$.

SYMBOL	PARAMETERS	MIN.	TYP.	MAX.	UNITS	CONDITIONS
t_F	Receiver Output Fall Time		3	6	ns	$C_L = 15pF$
t_{ZH}	Receiver Enable to Output High			50	ns	$C_L = 15pF$, Figure 14
t_{ZL}	Receiver Enable to Output Low			50	ns	$C_L = 15pF$, Figure 14
t_{HZ}	Receiver Disable from Output High			50	ns	$C_L = 15pF$, Figure 14
t_{LZ}	Receiver Disable from Output Low			50	ns	$C_L = 15pF$, Figure 14
$t_{ZH(SHDN)}$	Shutdown to Receiver Output Valid High			3500	ns	$C_L = 15pF$, Figure 14
$t_{ZL(SHDN)}$	Shutdown to Receiver Output Valid Low			3500	ns	$C_L = 15pF$, Figure 14
t_{SHDN}	Time to Shutdown	50	200	600	ns	Notes 3 and 4

NOTE:

1. *Change in Magnitude of Differential Output Voltage and Change in Magnitude of Common Mode Output Voltage are the changes in output voltage when DI input changes state.*
2. *Except devices which do not have \overline{DE} or \overline{RE} inputs.*
3. *The transceivers are put into shutdown by bringing \overline{RE} High and \overline{DE} Low simultaneously for at least 600ns. If the control inputs are in this state for less than 50ns, the device is guaranteed not enter shutdown. If the enable inputs are held in this state for at least 600ns the device is assured to be in shutdown. Note that the receiver and driver enable times increase during shutdown.*
4. *Guaranteed by design and bench characterization.*

FIGURE 3. DRIVER DC TEST CIRCUIT

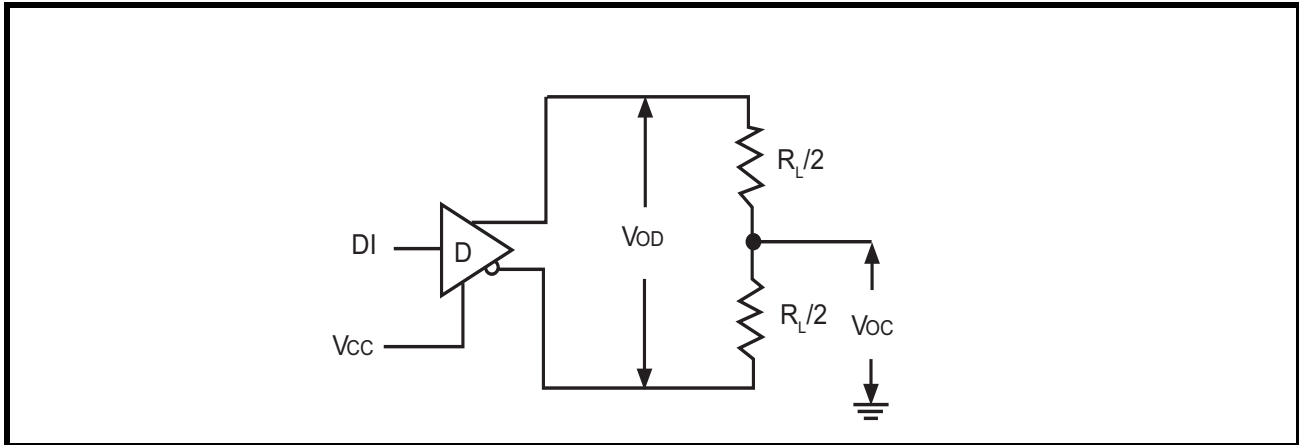

FIGURE 4. DRIVER COMMON MODE LOAD TEST

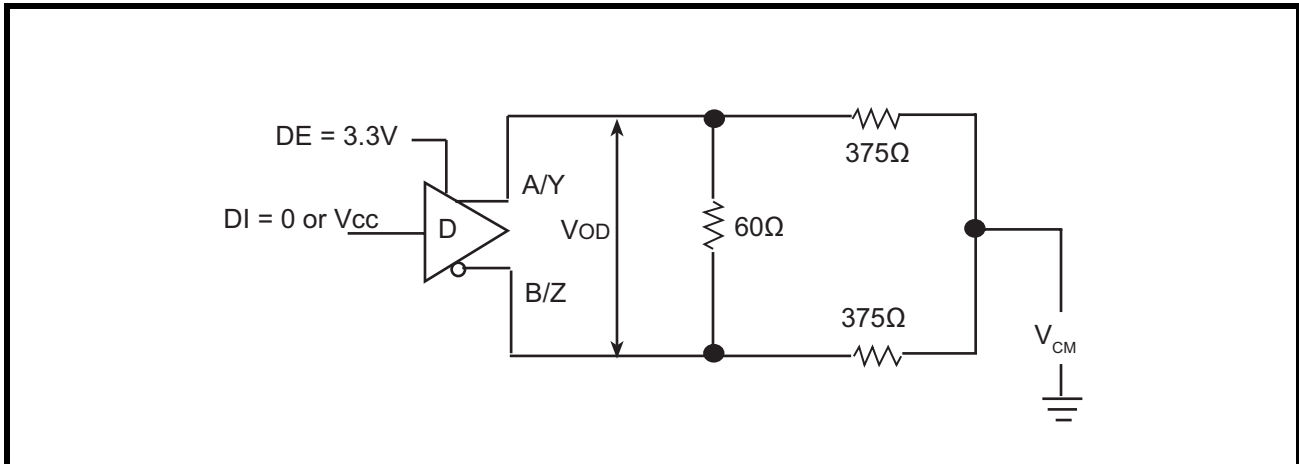

FIGURE 5. DRIVER SHORT CIRCUIT CURRENT LIMIT TEST

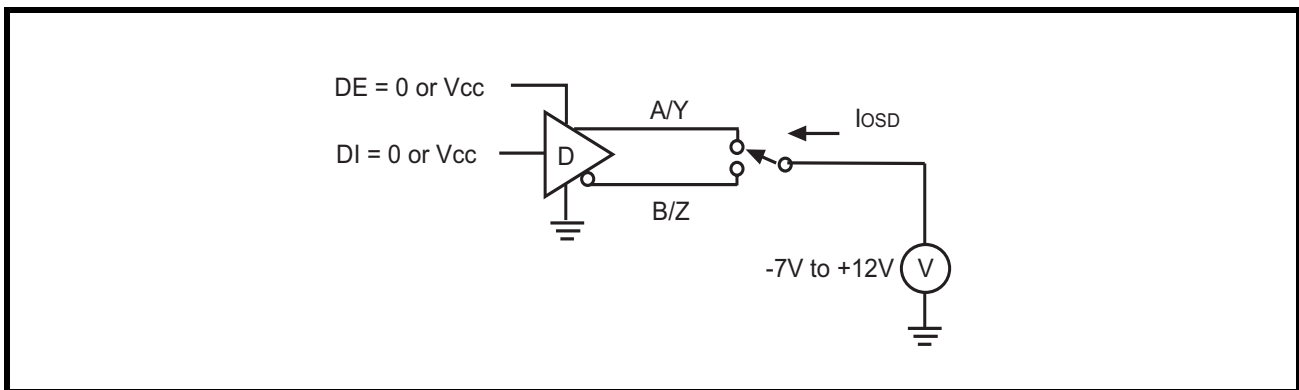

FIGURE 6. DRIVER PROPAGATION DELAY TEST CIRCUIT

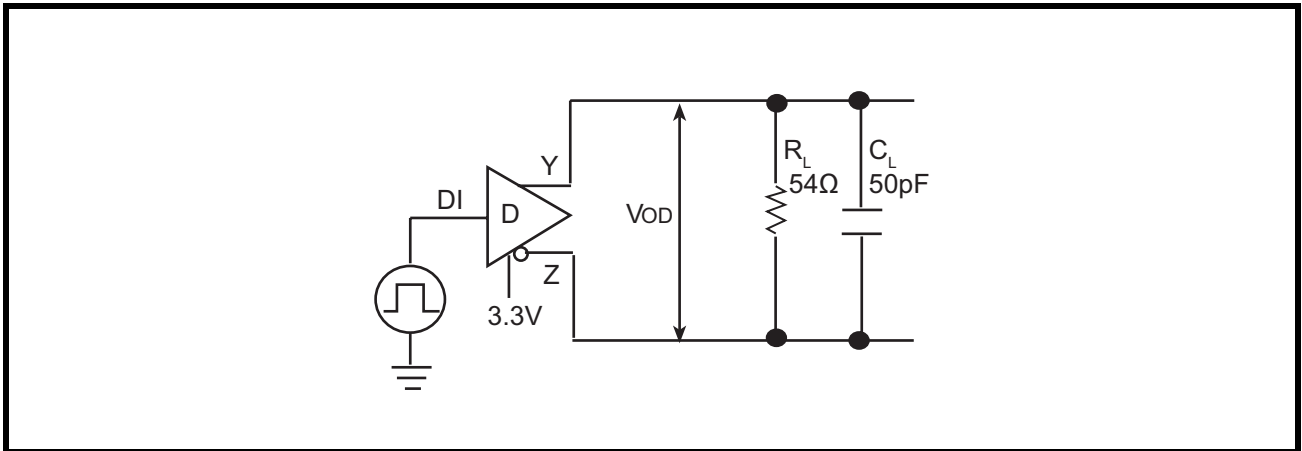

FIGURE 7. DRIVER PROPAGATION DELAY TIMING DIAGRAM

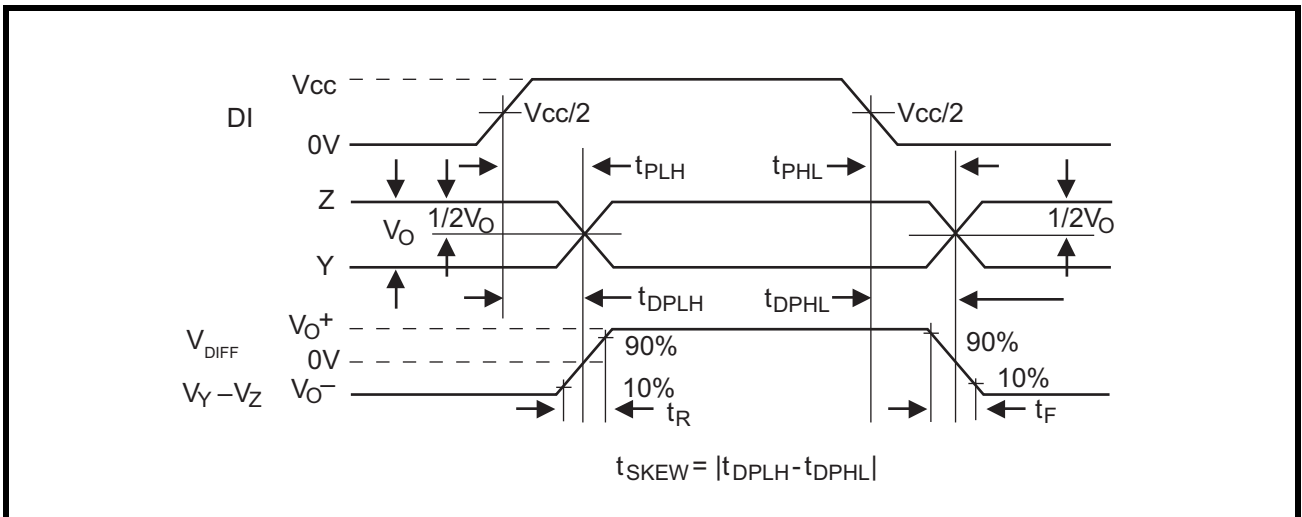

FIGURE 8. DRIVER ENABLE AND DISABLE TIME TEST CIRCUIT 1

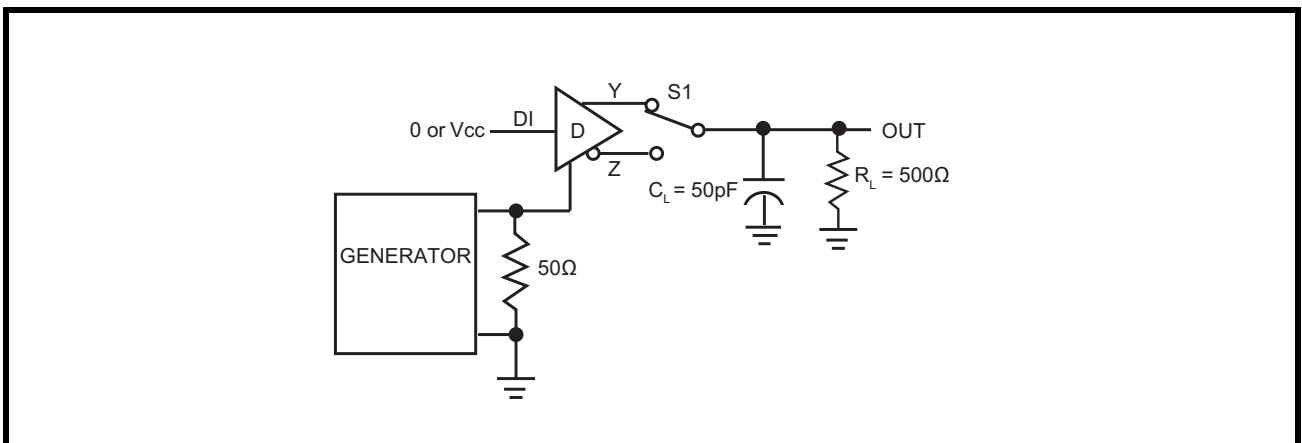

FIGURE 9. DRIVER ENABLE DISABLE TIMING DIAGRAM 1

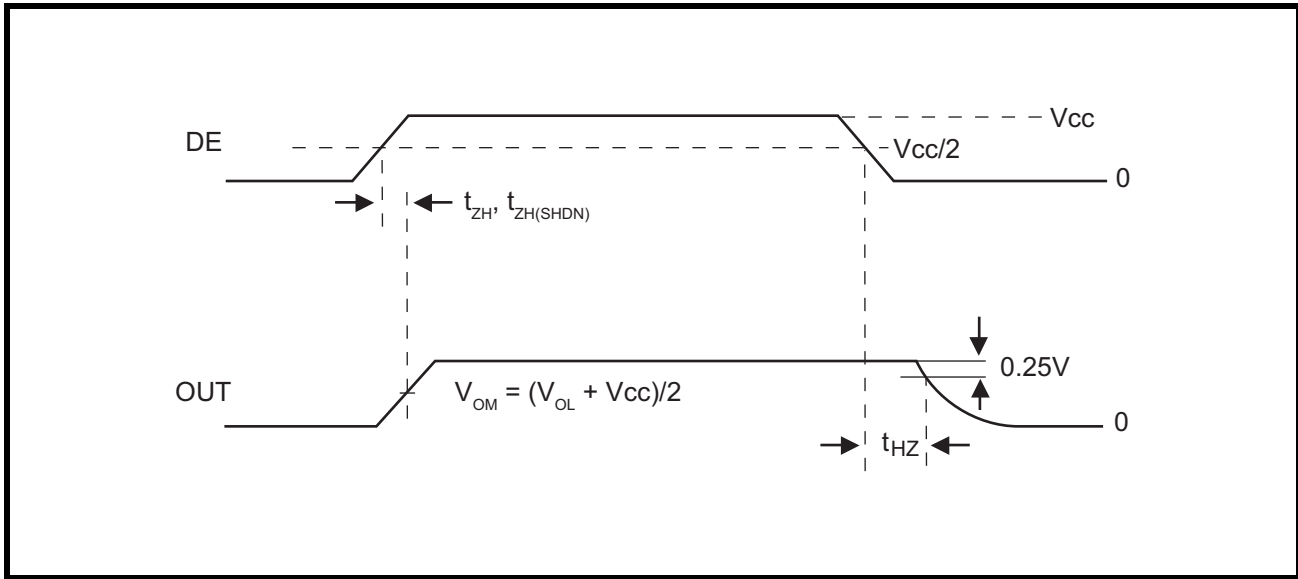

FIGURE 10. DRIVER ENABLE AND DISABLE TIME TEST CIRCUIT 2

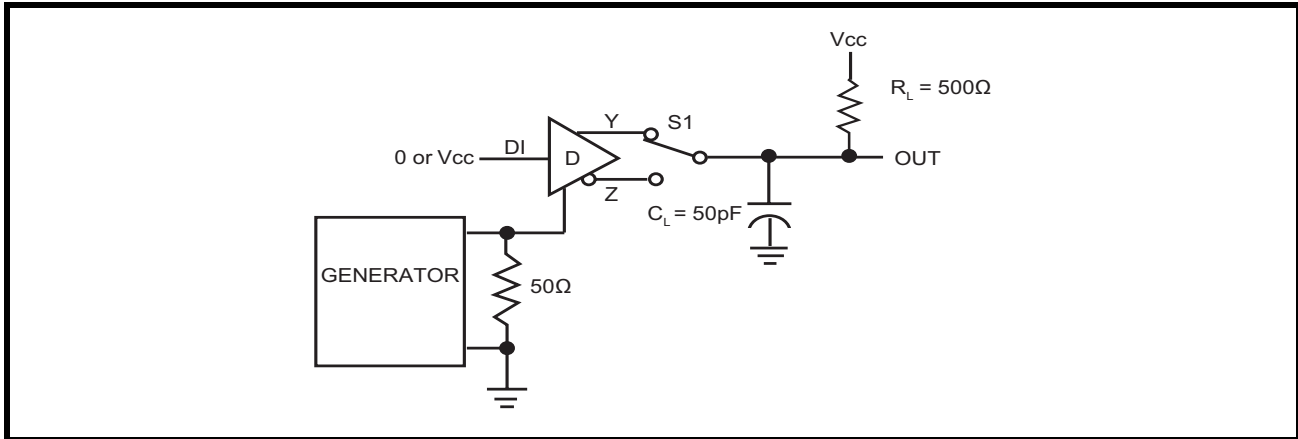

FIGURE 11. DRIVER ENABLE AND DISABLE TIMING DIAGRAM 2

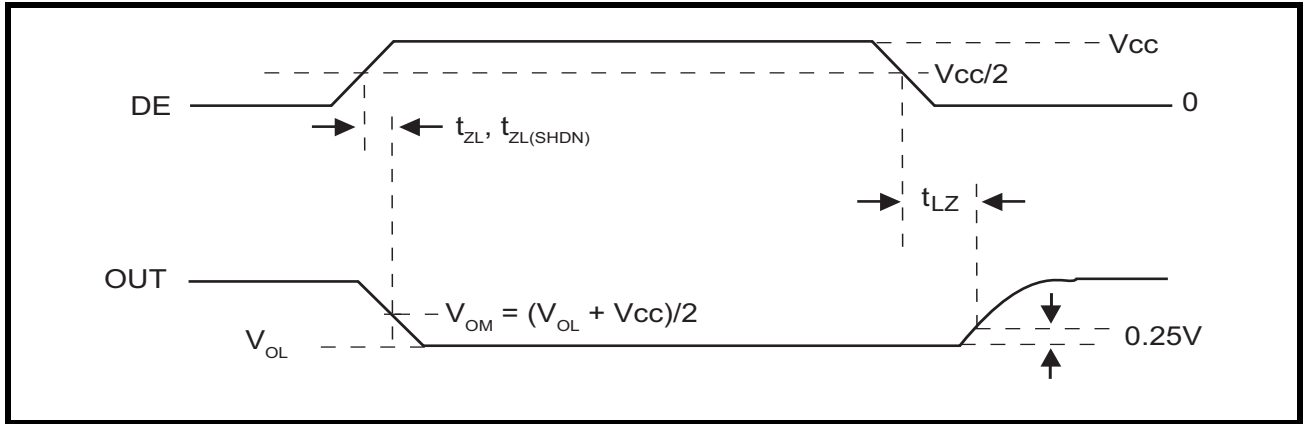

FIGURE 12. RECEIVER PROPAGATION DELAY TEST CIRCUIT

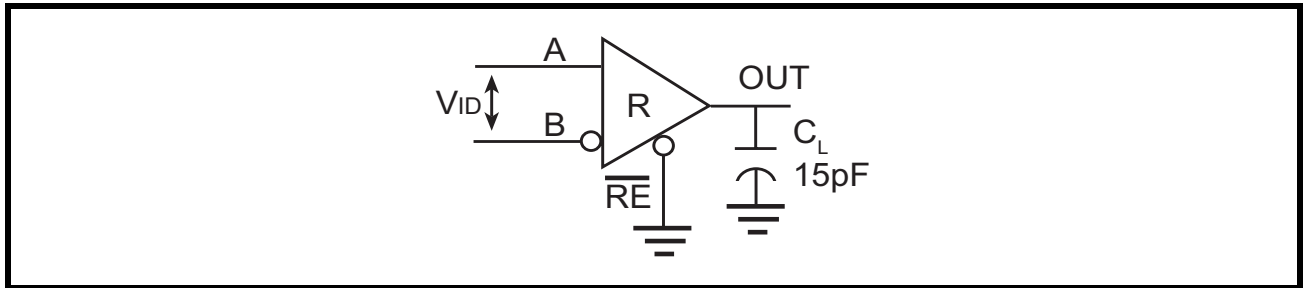

FIGURE 13. RECEIVER PROPAGATION DELAY TIMING DIAGRAM

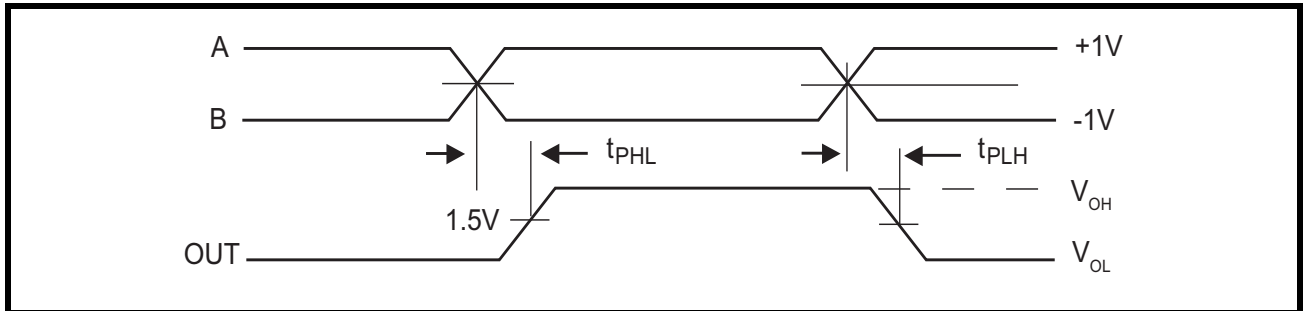

FIGURE 14. RECEIVER ENABLE AND DISABLE TIMES TEST CIRCUIT

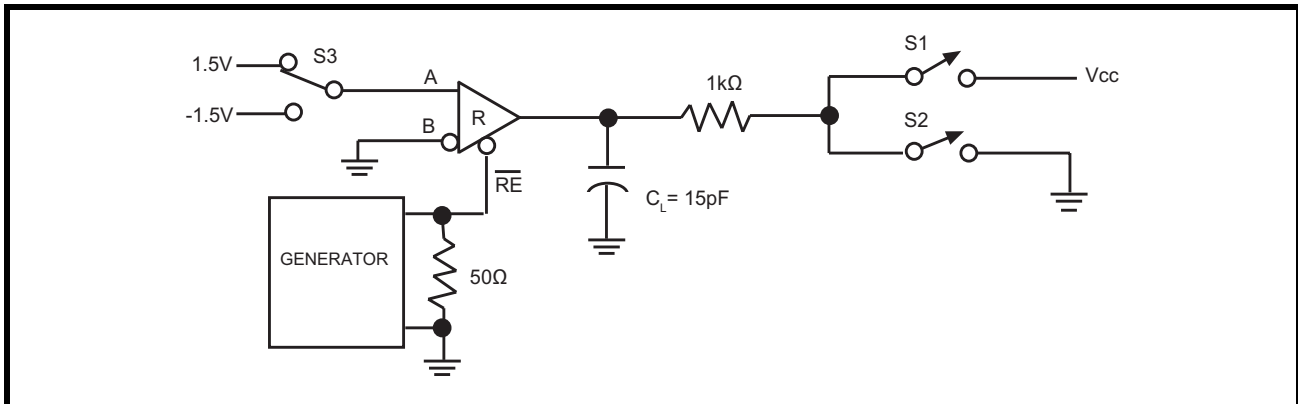

FIGURE 15. RECEIVER ENABLE AND DISABLE TIMING DIAGRAM 1

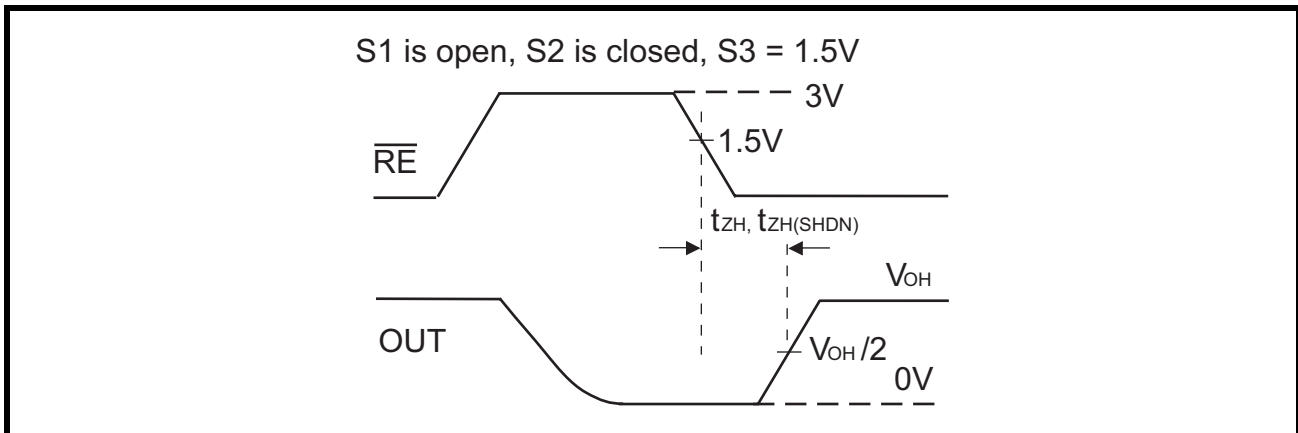

FIGURE 16. RECEIVER ENABLE AND DISABLE TIMING DIAGRAM 2

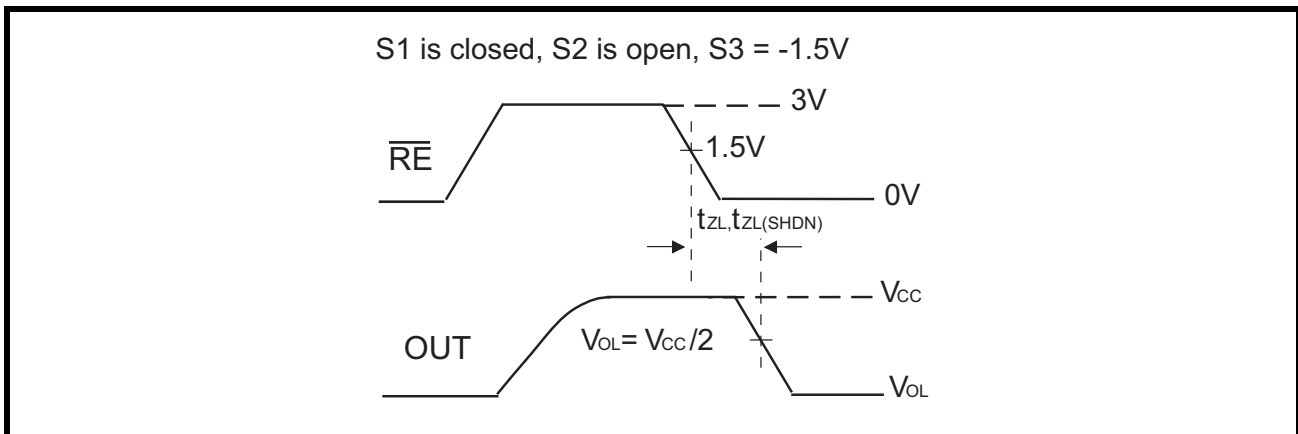

FIGURE 17. RECEIVER ENABLE AND DISABLE TIMING DIAGRAM 3

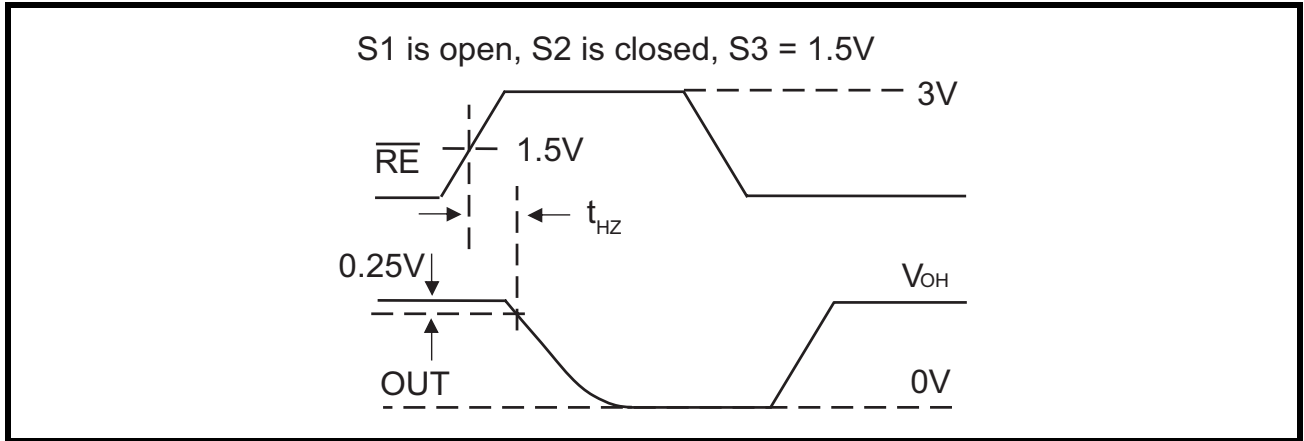
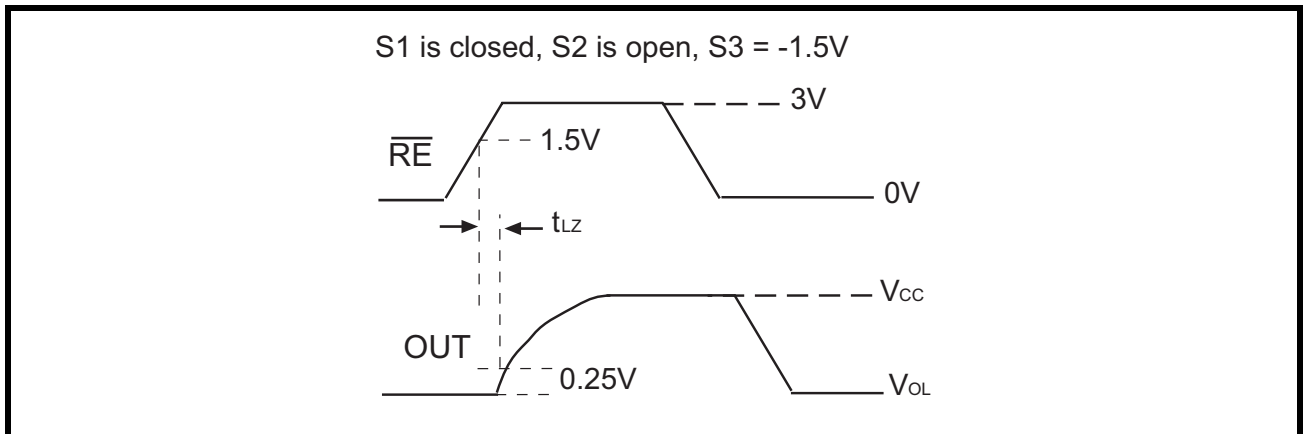

FIGURE 18. RECEIVER ENABLE AND DISABLE TIMING DIAGRAM 4



1.0 PRODUCT DESCRIPTION

XR3170E-XR3178E is a family of advanced RS-485/RS-422 transceivers. Each contains one driver and one receiver. All devices operate from a single +3.3V supply. The XR3172E, XR3175E and XR3178E are a half-duplex design while the other devices are full-duplex designs. The control pins \overline{RE} and DE feature a hotswap capability allowing live insertion without spurious data transfer. Drivers are output short-circuit current limited. Thermal-shutdown circuitry protects drivers against excessive power dissipation. When activated, the thermal-shutdown circuitry forces the driver output into a high-impedance state.

ADVANCED FAILSAFE

Ordinary RS-485 differential receivers will be in an indeterminate state whenever the data bus is not being actively driven. The Advanced Failsafe feature of the XR3170E family guarantees a logic-high receiver output when the receiver inputs are open or shorted, or when they are connected to a terminated transmission line with all drivers disabled. In a terminated bus with all transmitters disabled, the receivers' differential input voltage is pulled to 0V by the termination. The XR3170E family interprets 0V differential as a logic high with a minimum 50mV noise margin while maintaining compliance with the EIA/TIA-485 standard of +/-200mV.

RECEIVER INPUT FILTERING

XR3170E-XR3175E receivers incorporate input filtering in addition to input hysteresis. This filtering enhances noise immunity with differential signals that have very slow rise and fall times. Receiver propagation delay increases slightly due to this filtering. XR3176E, XR3177E and XR3178E high speed devices do not have this input filtering.

HOT-SWAP CAPABILITY

When Vcc is first applied the XR3170E family holds the driver enable and receiver enable inactive for approximately 10 microseconds. During power ramp-up other system IC's may drive unpredictable values. Hot-swap capability prevents the XR3170E family from driving any output signal until power has stabilized. After the initial power-up sequence, the hot-swap circuit becomes transparent and driver enable and receiver enable resume their normal functions and timings.

If circuit boards are inserted into an energized backplane (commonly called "live insertion" or "hot-swap") power may suddenly be applied to all circuits. Without the hot-swap capability, this situation could improperly enable the transceiver's driver or receiver, driving invalid data onto shared busses and possibly causing driver contention or device damage.

+/-15kV ESD PROTECTION

ESD protection structures are incorporated on all pins to protect against electrostatic discharges encountered during handling and assembly. The driver outputs and receiver inputs of the XR3170E family have extra protection against static electricity. Exar uses state of the art structures to protect these pins against ESD of +/-15kV without damage. The ESD structures withstand high ESD in all states: normal operation, shutdown and powered down. After an ESD event, the XR3170E-XR3178E keep operating without latch-up or damage.

ESD protection can be tested in various ways. The transmitter outputs and receiver inputs of the XR3170E-XR3178E are characterized for protection to the following limits:

- +/-15kV using the Human Body Model
- +/-8kV using the Contact Discharge Model
- +/-15kV Air-gap Discharge Model

ESD TEST CONDITIONS

ESD performance depends on a variety of conditions. Contact Exar for a reliability report that documents test setup, methodology and results.



IEC 61000-4-2

The IEC 61000-4-2 standard covers ESD testing and performance of finished equipment. However, it does not specifically refer to integrated circuits. The XR3170E family helps you design equipment to meet IEC 61000-4-2, without sacrificing board-space and cost for external ESD-protection components.

The major differences between tests done using the Human body model and IEC 61000-4-2 is a higher peak current in IEC 61000-4-2. Series resistance is lower in the IEC 61000-4-2 model. Hence, the ESD withstand voltage measured to IEC 61000-4-2 is generally lower than that of human body model.

The air-gap test involves approaching the device with a charged probe. The contact discharge method connects the probe to the device before the probe is energized.

MACHINE MODEL

The machine model for ESD tests all pins using a 200pF storage capacitor and zero discharge resistance. The objective is to emulate the stress caused when I/O pins are contacted by handling equipment during test and assembly.

256 TRANSCEIVERS ON THE BUS

The standard RS-485 receiver input impedance is 12k Ohms (1 unit load). A standard driver can drive up to 32 unit loads. The XR3170E family of transceivers have only a 1/8th unit load receiver input impedance of 96k Ohms, thereby allowing eight times as many, up to 256, transceivers to be connected in parallel on a communication line. Any combination of these devices and other RS-485 transceivers up to a total of 32 unit loads may be connected to the line.

LOW POWER SHUTDOWN MODE

Low-power shutdown mode is initiated by bringing both \overline{RE} high and DE low simultaneously. While in shutdown devices draw less than 1 μ A of supply current. DE and \overline{RE} may be tied together and driven by a single control signal. Devices are guaranteed not to enter shutdown if \overline{RE} is high and DE is low for less than 50ns. If the inputs are in this state for at least 600ns, the parts will enter shutdown.

Enable times t_{ZH} and t_{ZL} apply when the part is not in low-power shutdown state. Enable times $t_{ZH(SHDN)}$ and $t_{ZL(SHDN)}$ apply when the parts are shutdown. The drivers and receivers take longer to become enabled from low-power shutdown $t_{ZH(SHDN)}$ and $t_{ZL(SHDN)}$ than from driver / receiver disable mode (t_{ZH} and t_{ZL}).

DRIVER OUTPUT PROTECTION

Two mechanisms prevent excessive output current and power dissipation caused by faults or by bus contention. First, a driver current limit on the output stage provides immediate protection against short circuits over the whole common-mode voltage range. Second, a thermal-shutdown circuit forces the driver outputs into a high-impedance state if junction temperature becomes excessive.

LINE LENGTH

The RS-485/RS-422 standard covers line lengths up to 4000ft. Maximum achievable line length is a function of signal attenuation and noise. Termination prevents signal reflections by eliminating the impedance mismatches on a transmission line. Line termination is generally used if rise and fall times are shorter than the round-trip signal propagation time

2.0 FUNCTION TABLES

TABLE 1: FULL DUPLEX 14 PIN - XR3170E, XR3173E AND XR3176E

TRANSMITTING				
Inputs			Outputs	
\overline{RE}	DE	DI	Y	Z
X	1	1	1	0
X	1	0	0	1
0	0	X	High-Z	
1	0	X	Shutdown	

TABLE 2: FULL DUPLEX 8 PIN - XR3171E, XR3174E AND XR3177E

TRANSMITTING		
Input	Outputs	
DI	Y	Z
1	1	0
0	0	1

TABLE 3: HALF DUPLEX 8 PIN - XR3172E, XR2175E AND XR3178E

TRANSMITTING				
Inputs			Outputs	
\overline{RE}	DE	DI	A	B
X	1	1	1	0
X	1	0	0	1
0	0	X	High-Z	
1	0	X	Shutdown	

TABLE 4: FULL DUPLEX 14 PIN - XR3170E, XR3173E AND XR3176E

RECEIVING			
Inputs			Ouptut
\overline{RE}	DE	$V_A - V_B$	RO
0	X	$\geq -50mV$	1
0	X	$\leq -200mV$	0
0	X	Open/Shorted	1
1	1	X	High-Z
1	0	X	Shutdown

TABLE 5: FULL DUPLEX 8 PIN - XR3171E, XR3174E AND XR3177E

RECEIVING	
Inputs	Output
$V_A - V_B$	RO
$\geq -50mV$	1
$\leq -200mV$	0
Open/Shorted	1

TABLE 6: HALF DUPLEX 8 PIN - XR3172E, XR2175E AND XR3178E

RECEIVING			
Inputs			Output
\overline{RE}	DE	$V_A - V_B$	RO
0	X	$\geq -50mV$	1
0	X	$\leq -200mV$	0
0	X	Open/Shorted	1
1	1	X	High-Z
1	0	X	Shutdown

Note: Receiver inputs $-200mV < V_A - V_B < -50mV$ should be considered indeterminate.

3.0 PRODUCT SELECTOR GUIDE

TABLE 7: SELECTION GUIDE

PART NUMBER	DUPLEX	DATA RATE BPS	SHUTDOWN	RECEIVER AND DRIVER ENABLE	TRANS ON BUS	FOOT-PRINT
XR3170E	Full	250k	Yes	Yes	256	SN75180
XR3171E	Full	250k	No	No	256	SN75179
XR3172E	Half	250k	Yes	Yes	256	SN75176
XR3173E	Full	500k	Yes	Yes	256	SN75180
XR3174E	Full	500k	No	No	256	SN75179
XR3175E	Half	500k	Yes	Yes	256	SN75176
XR3176E	Full	20M	Yes	Yes	256	SN75180
XR3177E	Full	20M	No	No	256	SN75179
XR3178E	Half	20M	Yes	Yes	256	SN75176

4.0 TYPICAL APPLICATIONS:

Half-Duplex Network

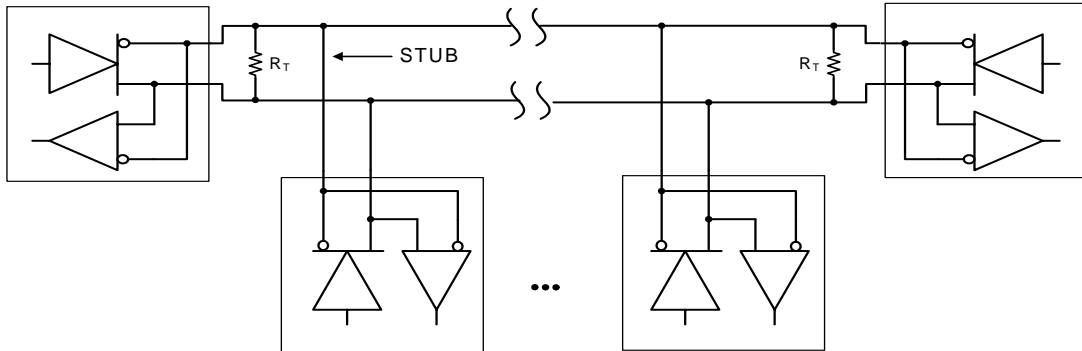

Bi-Directional Full-Duplex Network

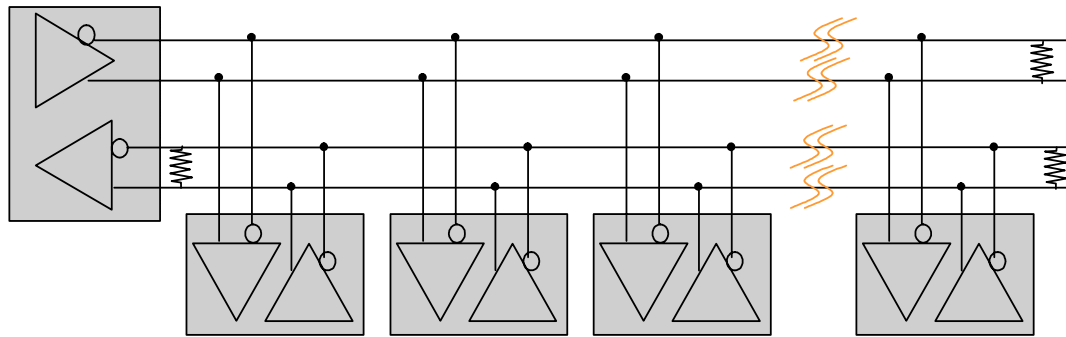

Point to Multi-point with Repeater

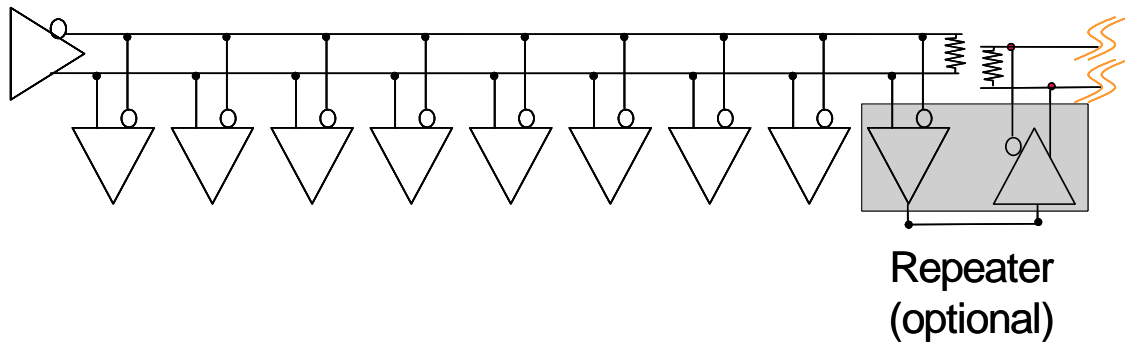

PACKAGE DIMENSIONS (14 PIN NSOIC)

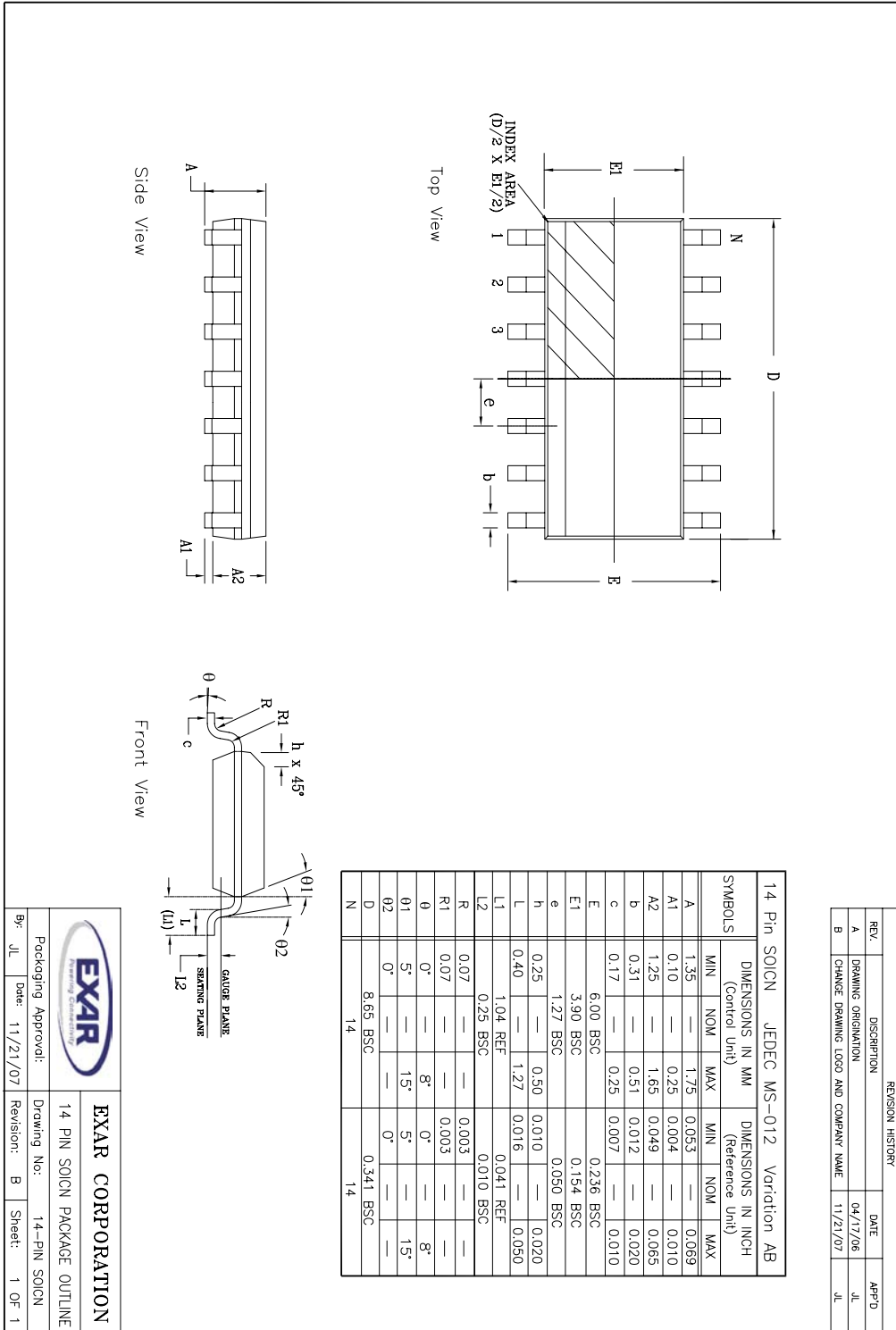

REVISION HISTORY			
REV.	DESCRIPTION	DATE	APP'D
A	DRAWING ORIGINATOR	04/17/06	JL
B	CHANGE DRAWING LOGO AND COMPANY NAME	11/21/07	JL

EXAR CORPORATION
 Packaging Approvals: 14 PIN SOICN PACKAGE OUTLINE
 Drawing No: 14-PIN SOICN
 By: JL Date: 11/21/07 Revisions: B Sheet: 1 OF 1

PACKAGE DIMENSIONS (8 PIN NSOIC)

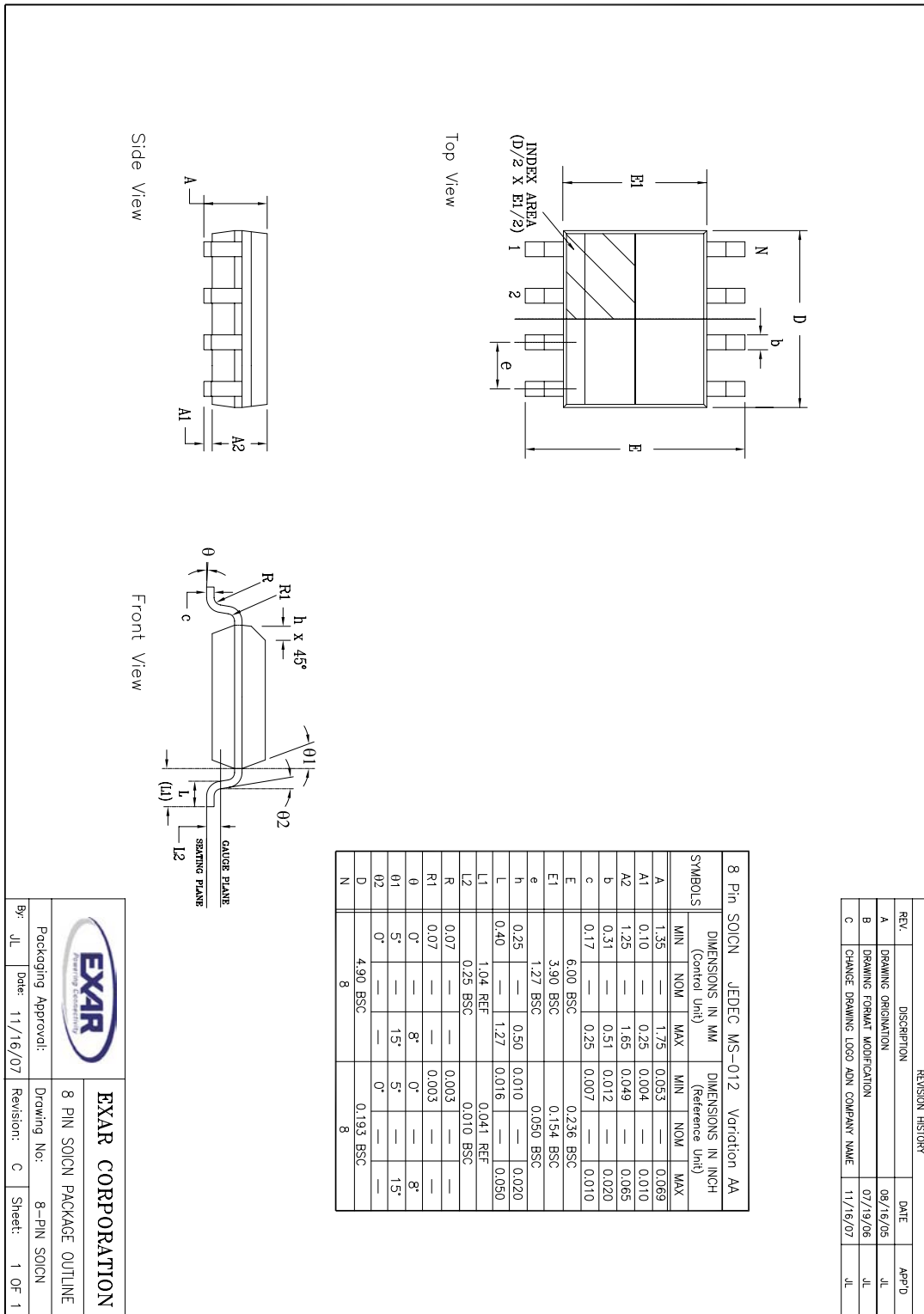



REVISION HISTORY

DATE	REVISION	DESCRIPTION
12/03/09	1.0.0	Production Release.

NOTICE

EXAR Corporation reserves the right to make changes to the products contained in this publication in order to improve design, performance or reliability. EXAR Corporation assumes no responsibility for the use of any circuits described herein, conveys no license under any patent or other right, and makes no representation that the circuits are free of patent infringement. Charts and schedules contained here in are only for illustration purposes and may vary depending upon a user’s specific application. While the information in this publication has been carefully checked; no responsibility, however, is assumed for inaccuracies.

EXAR Corporation does not recommend the use of any of its products in life support applications where the failure or malfunction of the product can reasonably be expected to cause failure of the life support system or to significantly affect its safety or effectiveness. Products are not authorized for use in such applications unless EXAR Corporation receives, in writing, assurances to its satisfaction that: (a) the risk of injury or damage has been minimized; (b) the user assumes all such risks; (c) potential liability of EXAR Corporation is adequately protected under the circumstances.

Copyright 2009 EXAR Corporation

Datasheet December 2009.

Send your UART technical inquiry with technical details to hotline: uarttechsupport@exar.com.

Reproduction, in part or whole, without the prior written consent of EXAR Corporation is prohibited.

Looking for pricing, stock, or lifecycle information?

Click below to explore more details on WIN SOURCE:

 [View XR3172EID-F on WIN SOURCE](#)

 [Exar Corporation](#) Information

Optimize Your Supply Chain with WIN SOURCE Solutions

-  Global Sourcing Solution
-  Obsolete Management
-  Cost Control Management
-  Shortage Management
-  Alternative Solution
-  Excess Inventory Management