



**THE DATASHEET OF
MTX-4503**





PART
NAME

EXTERNAL BRACKETS KIT

PART
No.

MTX-4503

REV.
DATE

10-27-15

DRAWING FOR REFERENCE

WE RESERVE THE RIGHT TO MAKE CHANGES TO OUR
STANDARD PRODUCTS. PLEASE CONSULT WITH BUD INDUSTRIES
PRIOR TO USING THIS DRAWING FOR DESIGN PURPOSE.

MATERIAL: STAINLESS STEEL 304

FINISH: NATURAL

DIMENSIONS IN INCH[MM]

KIT CONSISTS OF THE FOLLOWING ITEMS:

- QTY. (4) BRACKETS
- QTY. (4) M4 SCREWS
- QTY. (4) M4 FLAT WASHERS
- QTY. (4) M4 SPLIT LOCKWASHERS

WILL FIT THE FOLLOWING ENCLOSURES:

- #ATX-10501
- #ATX-10503

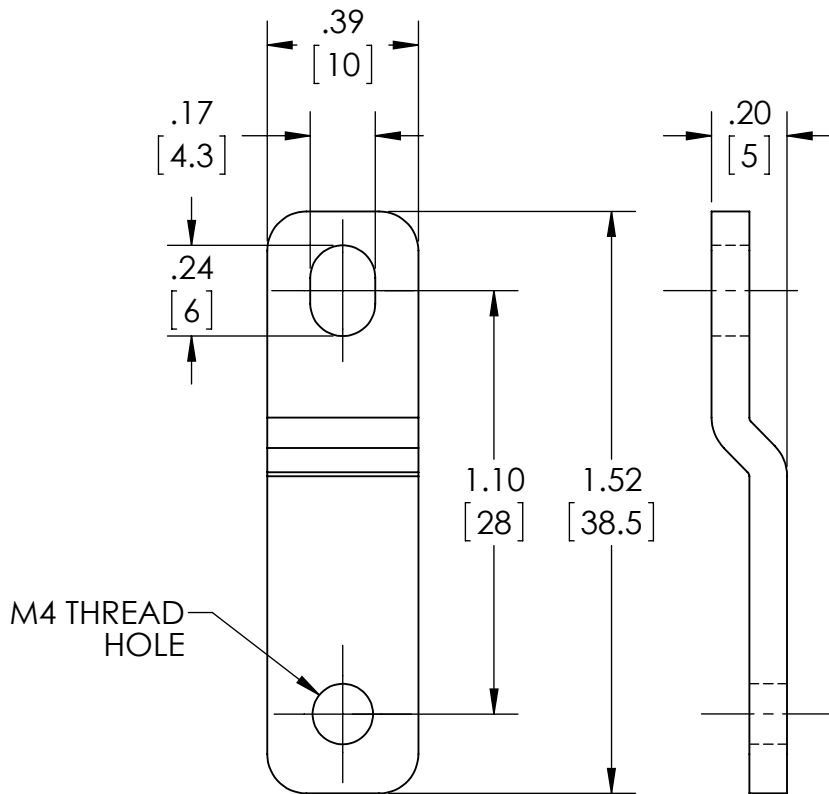

M4 THREAD
HOLE

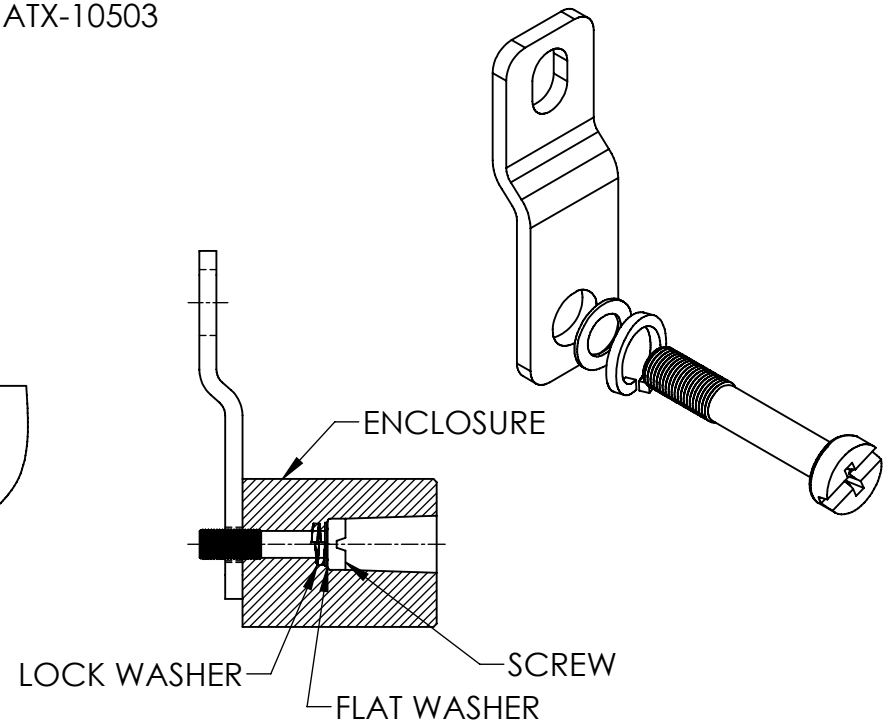
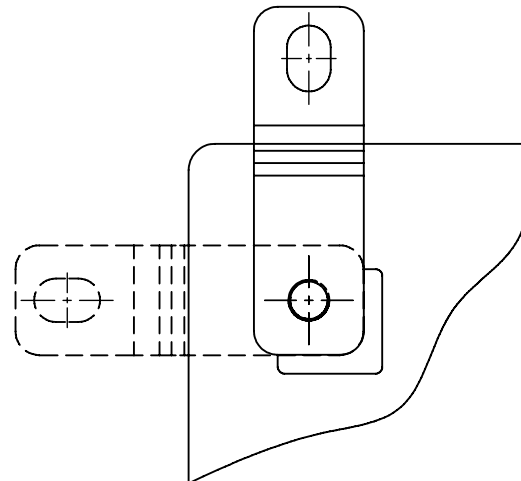

Looking for pricing, stock, or lifecycle information?

Click below to explore more details on WIN SOURCE:

 [View MTX-4503 on WIN SOURCE](#)

 [Bud Industries](#) Information

Optimize Your Supply Chain with WIN SOURCE Solutions

-  Global Sourcing Solution
-  Obsolete Management
-  Cost Control Management
-  Shortage Management
-  Alternative Solution
-  Excess Inventory Management