



**THE DATASHEET OF  
VCA2611Y/250**





# Dual, Variable-Gain Amplifier with Low-Noise Preamp

## FEATURES

- **LOW-NOISE PREAMP:**
  - Low Input Noise:  $0.95\text{nV}/\sqrt{\text{Hz}}$
  - Active Termination Noise Reduction
  - Switchable Termination Value
  - 80MHz Bandwidth
  - 5dB to 25dB Gain
  - Differential In and Out
- **LOW-NOISE VARIABLE GAIN AMPLIFIER:**
  - Low-Noise VCA
  - Up to 40dB Gain Range
  - 40MHz Bandwidth
  - Differential In and Out
- **LOW CROSSTALK:** 66dB at Max Gain, 5MHz
- **HIGH-SPEED VARIABLE GAIN ADJUST**
- **SWITCHABLE EXTERNAL PROCESSING**

## APPLICATIONS

- **ULTRASOUND SYSTEMS**
- **WIRELESS RECEIVERS**
- **TEST EQUIPMENT**

## DESCRIPTION

The VCA2616 and VCA2611 are dual, Low-Noise Preamplifiers (LNP), plus low-noise Variable Gain Amplifiers (VGA). The VCA2611 is an upgraded version of the VCA2616. The only difference between the VCA2616 and the VCA2611 is the input structure to the LNP. The VCA2616 is limited to  $-0.3\text{V}$  negative-going input spikes; the VCA2611 is limited to  $-2.0\text{V}$  negative-going input spikes. This change allows the user to use slower and less expensive input clamping diodes prior to the LNP input. In some designs, input clamping may not be required.

The combination of Active Termination (AT) and Maximum Gain Select (MGS) allow for the best noise performance. The VCA2616 and VCA2611 also feature low crosstalk and outstanding distortion performance.

The LNP has differential input and output capability and is strappable for gains of 5dB, 17dB, 22dB, or 25dB. Low input impedance is achieved by AT, resulting in as much as a 4.6dB improvement in noise figure over conventional shunt termination. The termination value can also be switched to accommodate different sources. The output of the LNP is available for external signal processing.

The variable gain is controlled by an analog voltage whose gain varies from 0dB to the gain set by the MGS. The ability to program the variable gain also allows the user to optimize dynamic range. The VCA input can be switched from the LNP to external circuits for different applications. The output can be used in either a single-ended or differential mode to drive high-performance Analog-to-Digital (A/D) converters, and is cleanly limited for optimum overdrive recovery.

The combination of low noise, gain, and gain range programmability makes the VCA2616 and VCA2611 versatile building blocks in a number of applications where noise performance is critical. The VCA2616 and VCA2611 are available in a TQFP-48 package.

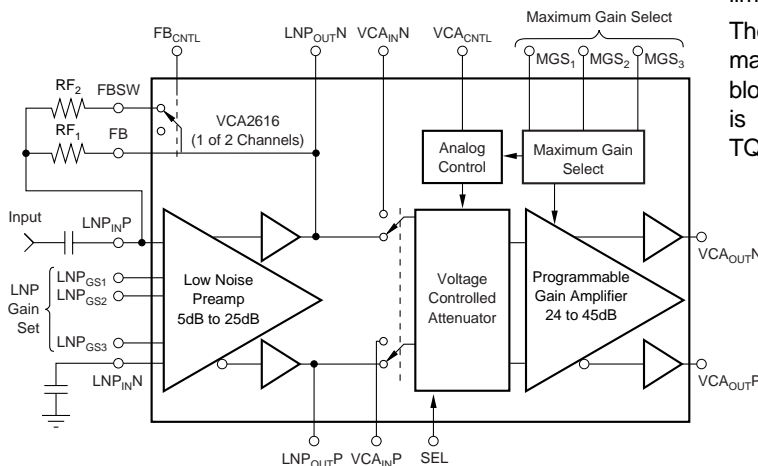

Please be aware that an important notice concerning availability, standard warranty, and use in critical applications of Texas Instruments semiconductor products and disclaimers thereto appears at the end of this data sheet.

All trademarks are the property of their respective owners.

## ABSOLUTE MAXIMUM RATINGS<sup>(1)</sup>

Power Supply (+V <sub>S</sub> )	+6V
VCA2616 Analog Input	-0.3V to (+V <sub>S</sub> + 0.3V)
VCA2611 Analog Input	-2.0V to (+V <sub>S</sub> + 0.3V)
Logic Input	-0.3V to (+V <sub>S</sub> + 0.3V)
Case Temperature	+100°C
Junction Temperature	+150°C
Storage Temperature	-40°C to +150°C

NOTE: (1) Stresses above those listed under "Absolute Maximum Ratings" may cause permanent damage to the device. Exposure to absolute maximum conditions for extended periods may affect device reliability.



## ELECTROSTATIC DISCHARGE SENSITIVITY

This integrated circuit can be damaged by ESD. Texas Instruments recommends that all integrated circuits be handled with appropriate precautions. Failure to observe proper handling and installation procedures can cause damage.

ESD damage can range from subtle performance degradation to complete device failure. Precision integrated circuits may be more susceptible to damage because very small parametric changes could cause the device not to meet its published specifications.

## PACKAGE/ORDERING INFORMATION<sup>(1)</sup>

PRODUCT	PACKAGE-LEAD	PACKAGE DESIGNATOR	SPECIFIED TEMPERATURE RANGE	PACKAGE MARKING	ORDERING NUMBER	TRANSPORT MEDIA, QUANTITY
VCA2616	TQFP-48	PFB	-40°C to +85°C	VCA2616	VCA2616YT	Tape and Reel, 250
"	"	"	"	"	VCA2616YR	Tape and Reel, 2000
VCA2611	TQFP-48	PFB	-40°C to +85°C	VCA2611	VCA2611Y/250	Tape and Reel, 250
"	"	"	"	"	VCA2611Y/2K	Tape and Reel, 2000

NOTE: (1) For the most current package and ordering information, see the Package Option Addendum located at the end of this data sheet.

## ELECTRICAL CHARACTERISTICS

At T<sub>A</sub> = +25°C, V<sub>DDB</sub> = V<sub>DDB</sub> = V<sub>DDR</sub> = +5V, load resistance = 500Ω on each output to ground, MGS = 011, LNP = 22dB and f<sub>IN</sub> = 5MHz, unless otherwise noted. The input to the preamp (LNP) is single-ended, and the output from the VCA is single-ended, unless otherwise noted.

PARAMETER	CONDITIONS	VCA2616Y, VCA2611Y			UNITS
		MIN	TYP	MAX	
<b>PREAMPLIFIER</b>					
Input Resistance			600		kΩ
Input Capacitance			15		pF
Input Bias Current			1		nA
CMRR	f = 1MHz, VCA <sub>CNTL</sub> = 0.2V		50		dB
Maximum Input Voltage	Preamp Gain = +5dB		1		V <sub>PP</sub>
Input Voltage Noise <sup>(1)</sup>	Preamp Gain = +25dB		112		mV <sub>PP</sub>
	Preamp Gain = +5dB		4.2		nV/√Hz
	Preamp Gain = +25dB		0.95		nV/√Hz
Input Current Noise	Independent of Gain		0.35		pA/√Hz
Noise Figure, R <sub>S</sub> = 75Ω, R <sub>IN</sub> = 75Ω <sup>(1)</sup>	R <sub>F</sub> = 550Ω, Preamp Gain = 22dB, PGA Gain = 39dB		6.2		dB
Bandwidth	Gain = 22dB		80		MHz
<b>PROGRAMMABLE VARIABLE GAIN AMPLIFIER</b>					
Peak Input Voltage	Differential		2		V <sub>PP</sub>
-3dB Bandwidth			40		MHz
Slew Rate			300		V/μs
Output Signal Range	R <sub>L</sub> ≥ 500Ω Each Side to Ground		2		V <sub>PP</sub>
Output Impedance	f = 5MHz		1		Ω
Output Short-Circuit Current			±40		mA
3rd-Harmonic Distortion	f = 5MHz, V <sub>OUT</sub> = 1V <sub>PP</sub> , VCA <sub>CNTL</sub> = 3.0V	-45	-71		dBc
2nd-Harmonic Distortion	f = 5MHz, V <sub>OUT</sub> = 1V <sub>PP</sub> , VCA <sub>CNTL</sub> = 3.0V	-45	-63		dBc
IMD, 2-Tone	V <sub>OUT</sub> = 2V <sub>PP</sub> , f = 1MHz		-75		dBc
	V <sub>OUT</sub> = 2V <sub>PP</sub> , f = 10MHz		-75		dBc
Crosstalk	VCA <sub>CNTL</sub> = 0.2V		-66		dB
Group Delay Variation	1MHz < f < 10MHz, Full Gain Range		±2		ns
DC Output Level, V <sub>IN</sub> = 0			2.5		V
<b>ACCURACY</b>					
Gain Slope			10.9		dB/V
Gain Error				±1 <sup>(2)</sup>	dB
Output Offset Voltage			±50		mV
Total Gain	VCA <sub>CNTL</sub> = 0.2V	18	21	24	dB
	VCA <sub>CNTL</sub> = 3.0V	47	50	53	dB
<b>GAIN CONTROL INTERFACE</b>					
Input Voltage (VCA <sub>CNTL</sub> ) Range			0.2 to 3.0		V
Input Resistance			1		MΩ
Response Time	40dB Gain Change, MGS = 111		0.2		μs
<b>POWER SUPPLY</b>					
Operating Temperature Range		-40		+85	°C
Specified Operating Range		4.75	5.0	5.25	V
Power Dissipation	Operating, Both Channels		410	495	mW

NOTES: (1) For preamp driving VGA.

(2) Referenced to best fit dB-linear curve.

## PIN CONFIGURATION

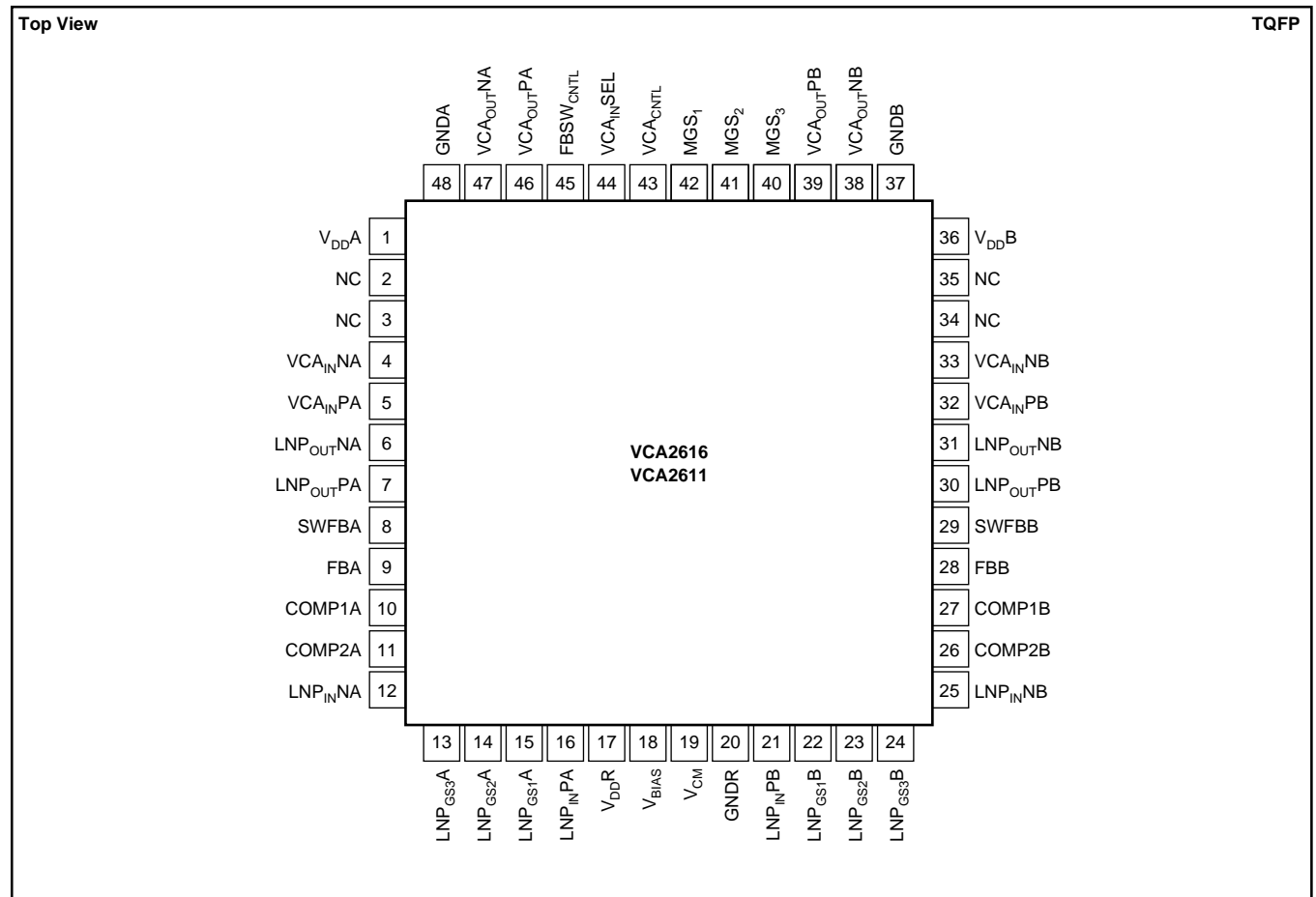

## PIN DESCRIPTIONS

PIN	DESIGNATOR	DESCRIPTION	PIN	DESIGNATOR	DESCRIPTION
1	V <sub>DDA</sub>	Channel A +Supply	25	LNP <sub>IN</sub> NB	Channel B LNP Inverting Input
2	NC	Do Not Connect	26	COMP2B	Channel B Frequency Compensation 2
3	NC	Do Not Connect	27	COMP1B	Channel B Frequency Compensation 1
4	VCA <sub>IN</sub> NA	Channel A VCA Negative Input	28	FBB	Channel B Feedback Output
5	VCA <sub>IN</sub> PA	Channel A VCA Positive Input	29	SWFBB	Channel B Switched Feedback Output
6	LNP <sub>OUT</sub> NA	Channel A LNP Negative Output	30	LNP <sub>OUT</sub> PB	Channel B LNP Positive Output
7	LNP <sub>OUT</sub> PA	Channel A LNP Positive Output	31	LNP <sub>OUT</sub> NB	Channel B LNP Negative Output
8	SWFBA	Channel A Switched Feedback Output	32	VCA <sub>IN</sub> PB	Channel B VCA Positive Input
9	FBA	Channel A Feedback Output	33	VCA <sub>IN</sub> NB	Channel B VCA Negative Input
10	COMP1A	Channel A Frequency Compensation 1	34	NC	Do Not Connect
11	COMP2A	Channel A Frequency Compensation 2	35	NC	Do Not Connect
12	LNP <sub>IN</sub> NA	Channel A LNP Inverting Input	36	V <sub>DD</sub> B	Channel B +Analog Supply
13	LNP <sub>GS3</sub> A	Channel A LNP Gain Strap 3	37	GND	Channel B Analog Ground
14	LNP <sub>GS2</sub> A	Channel A LNP Gain Strap 2	38	VCA <sub>OUT</sub> NB	Channel B VCA Negative Output
15	LNP <sub>GS1</sub> A	Channel A LNP Gain Strap 1	39	VCA <sub>OUT</sub> PB	Channel B VCA Positive Output
16	LNP <sub>IN</sub> PA	Channel A LNP Noninverting Input	40	MGS <sub>3</sub>	Maximum Gain Select 3 (LSB)
17	V <sub>DD</sub> R	+Supply for Internal Reference	41	MGS <sub>2</sub>	Maximum Gain Select 2
18	V <sub>BIAS</sub>	0.01μF Bypass to Ground	42	MGS <sub>1</sub>	Maximum Gain Select 1 (MSB)
19	V <sub>CM</sub>	0.01μF Bypass to Ground	43	VCA <sub>CNTL</sub>	VCA Control Voltage
20	GND	Ground for Internal Reference	44	VCA <sub>IN</sub> SEL	VCA Input Select, HI = External
21	LNP <sub>IN</sub> PB	Channel B LNP Noninverting Input	45	FBSW <sub>CNTL</sub>	Feedback Switch Control: HI = ON
22	LNP <sub>GS1</sub> B	Channel B LNP Gain Strap 1	46	VCA <sub>OUT</sub> PA	Channel A VCA Positive Output
23	LNP <sub>GS2</sub> B	Channel B LNP Gain Strap 2	47	VCA <sub>OUT</sub> NA	Channel A VCA Negative Output
24	LNP <sub>GS3</sub> B	Channel B LNP Gain Strap 3	48	GND	Channel A Analog Ground

# TYPICAL CHARACTERISTICS

At  $T_A = +25^\circ\text{C}$ ,  $V_{DDA} = V_{DDB} = V_{DDR} = +5\text{V}$ , load resistance =  $500\Omega$  on each output to ground,  $\text{MGS} = 011$ ,  $\text{LNP} = 22\text{dB}$  and  $f_{\text{IN}} = 5\text{MHz}$ , unless otherwise noted. The input to the preamp (LNP) is single-ended, and the output from the VCA is single-ended, unless otherwise noted. This results in a 6dB reduction in signal amplitude compared to differential operation.

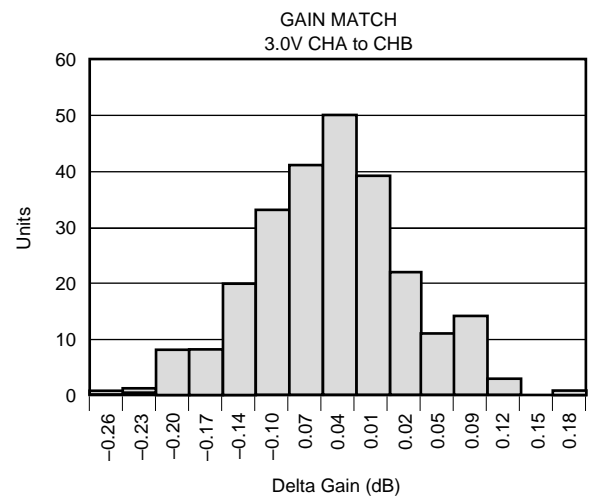
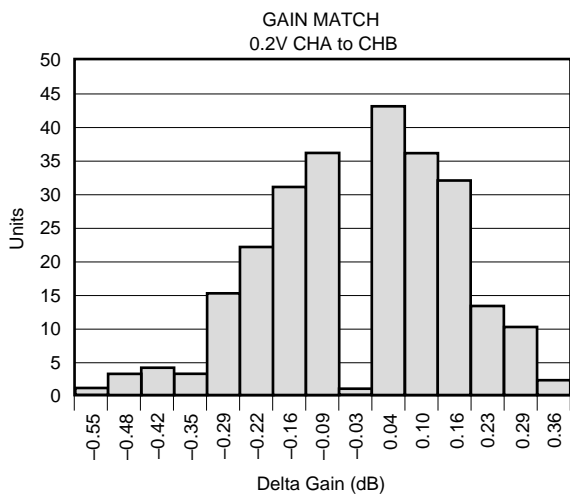
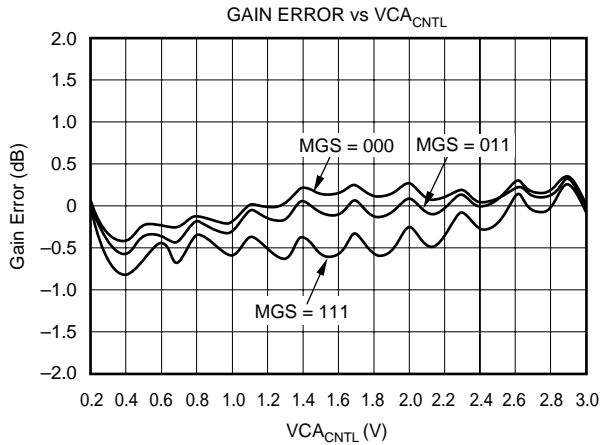
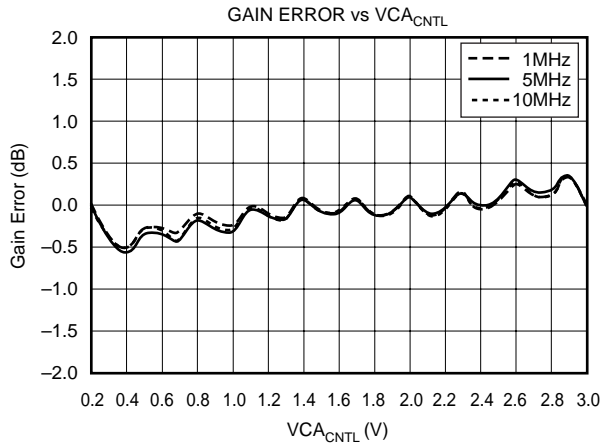
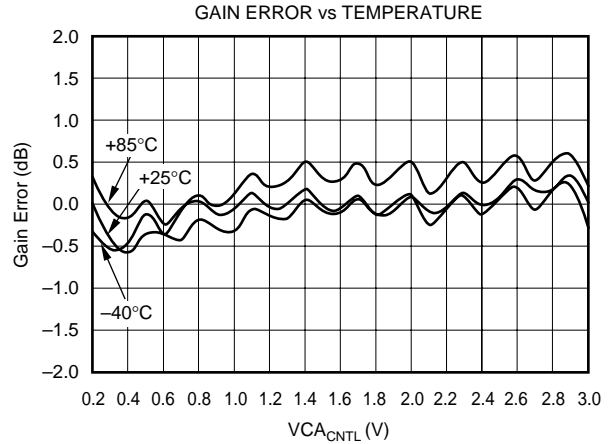
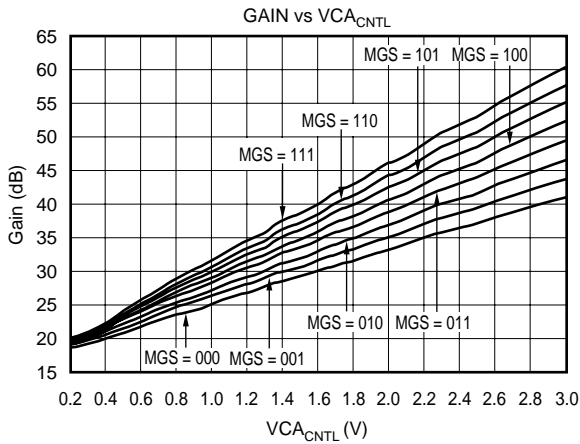

# TYPICAL CHARACTERISTICS (Cont.)

At  $T_A = +25^\circ\text{C}$ ,  $V_{DDA} = V_{DDB} = V_{DDR} = +5\text{V}$ , load resistance =  $500\Omega$  on each output to ground,  $\text{MGS} = 011$ ,  $\text{LNP} = 22\text{dB}$  and  $f_{\text{IN}} = 5\text{MHz}$ , unless otherwise noted. The input to the preamp (LNP) is single-ended, and the output from the VCA is single-ended, unless otherwise noted. This results in a 6dB reduction in signal amplitude compared to differential operation.

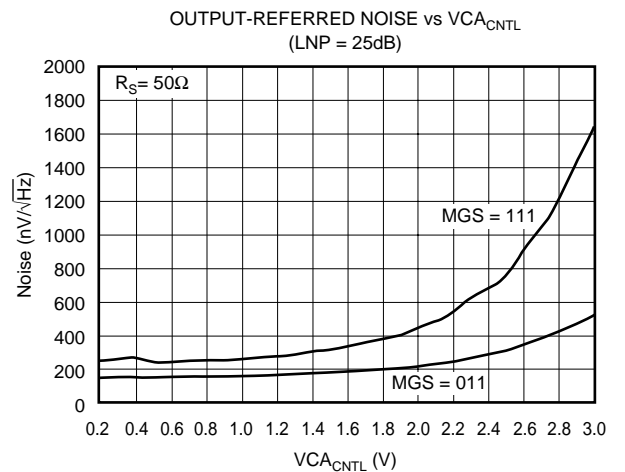
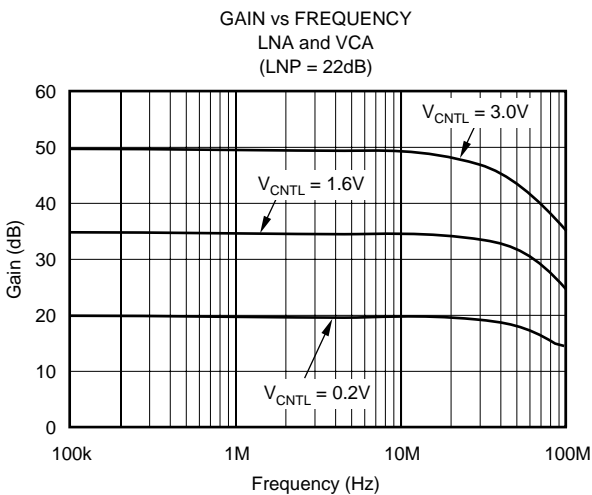
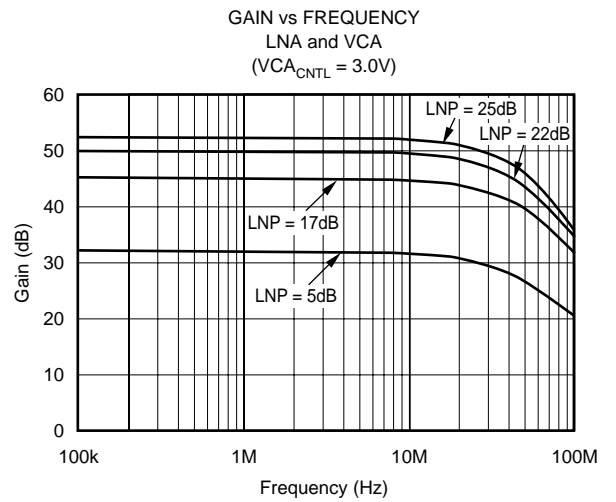
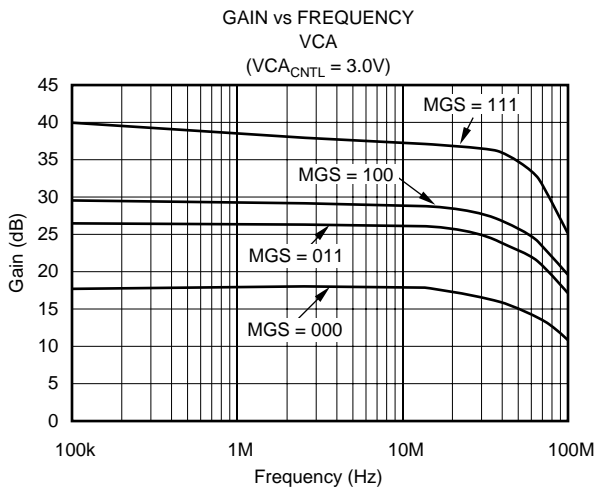
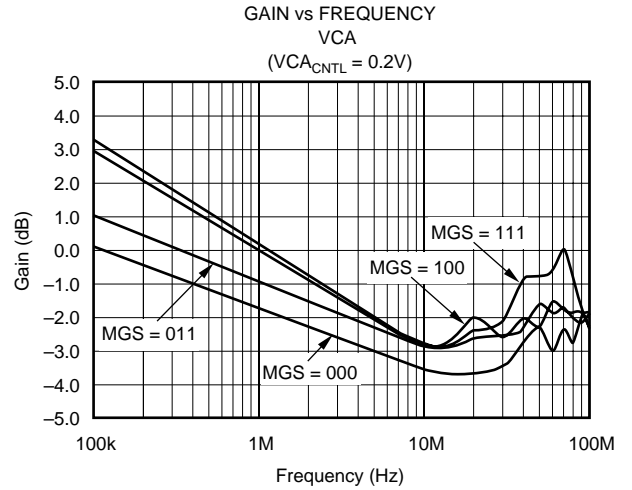
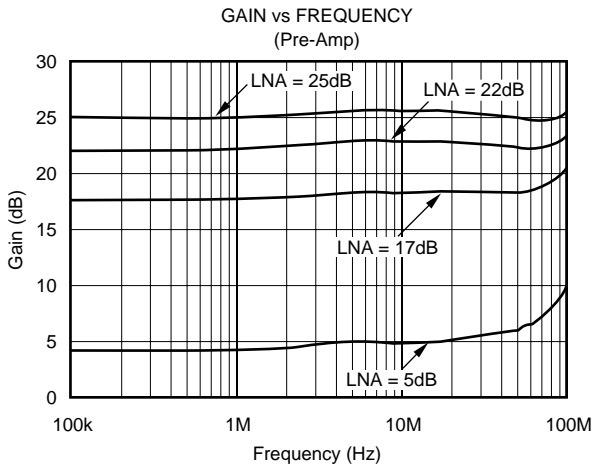

# TYPICAL CHARACTERISTICS (Cont.)

At  $T_A = +25^\circ\text{C}$ ,  $V_{DDA} = V_{DDB} = V_{DDR} = +5\text{V}$ , load resistance =  $500\Omega$  on each output to ground,  $\text{MGS} = 011$ ,  $\text{LNP} = 22\text{dB}$  and  $f_{IN} = 5\text{MHz}$ , unless otherwise noted. The input to the preamp (LNP) is single-ended, and the output from the VCA is single-ended unless otherwise noted. This results in a 6dB reduction in signal amplitude compared to differential operation.

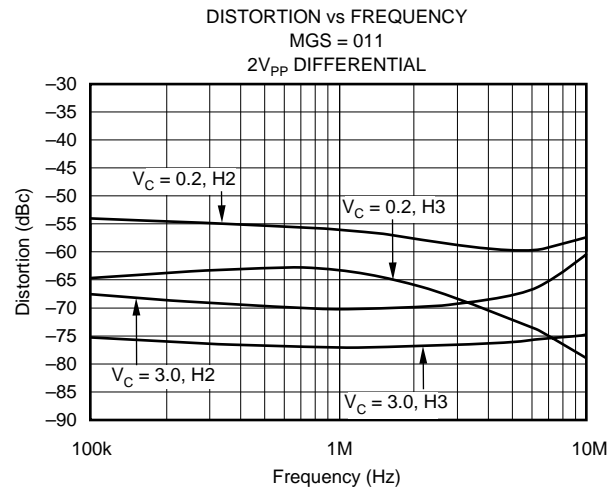
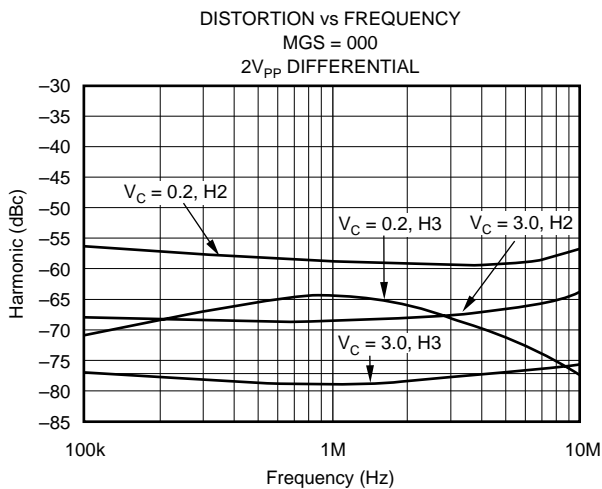
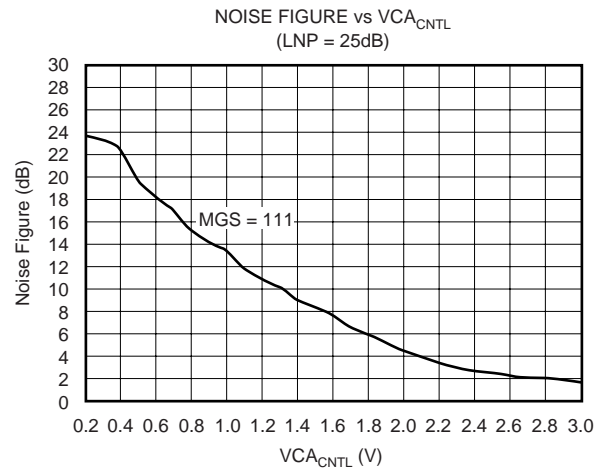
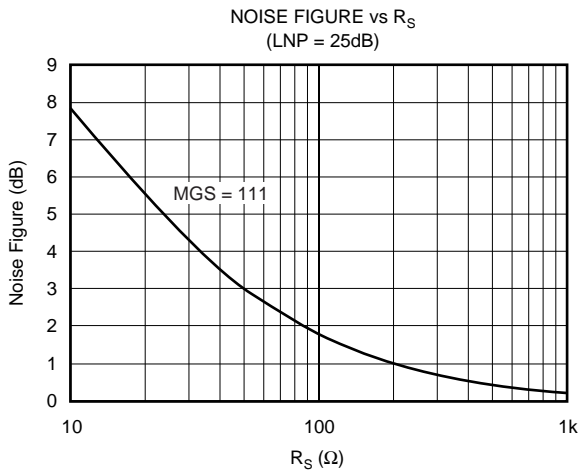
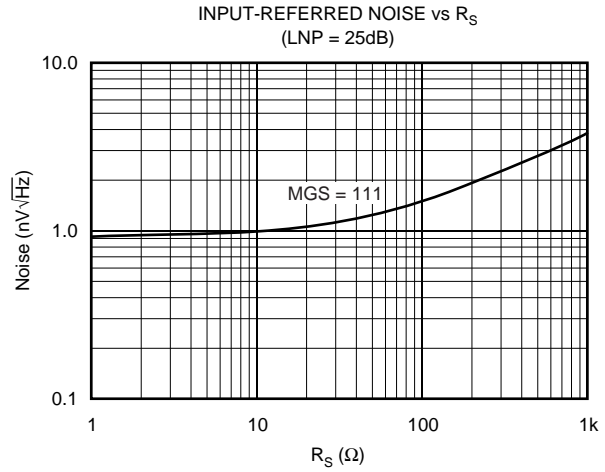
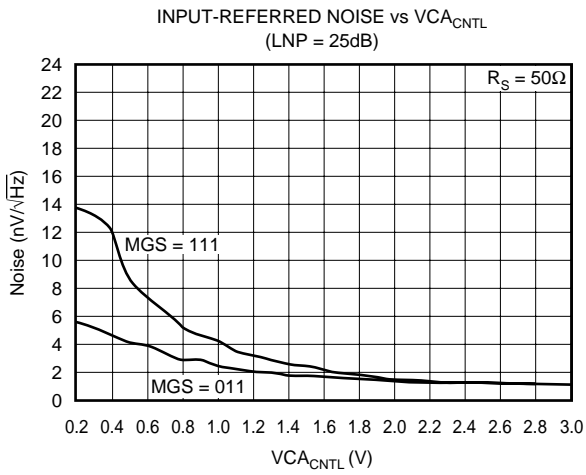

# TYPICAL CHARACTERISTICS (Cont.)

At  $T_A = +25^\circ\text{C}$ ,  $V_{DDA} = V_{ddb} = V_{DDR} = +5\text{V}$ , load resistance =  $500\Omega$  on each output to ground,  $\text{MGS} = 011$ ,  $\text{LNP} = 22\text{dB}$  and  $f_{IN} = 5\text{MHz}$ , unless otherwise noted. The input to the preamp (LNP) is single-ended, and the output from the VCA is single-ended, unless otherwise noted. This results in a 6dB reduction in signal amplitude compared to differential operation.

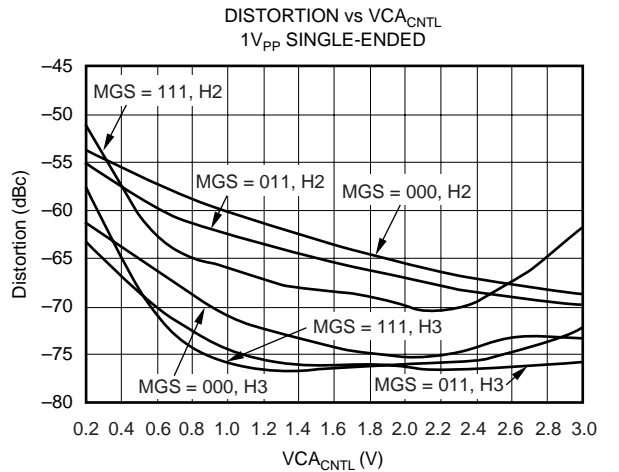
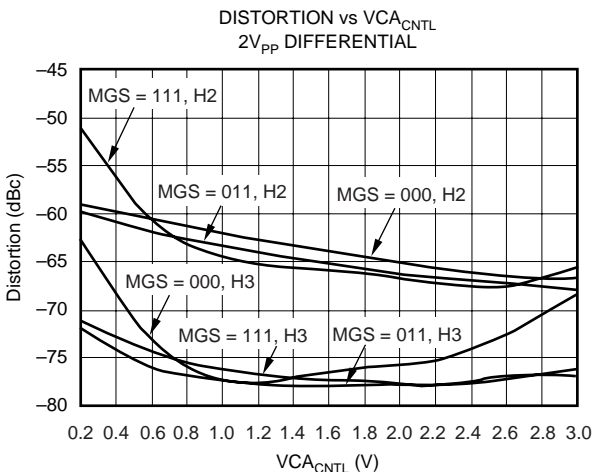
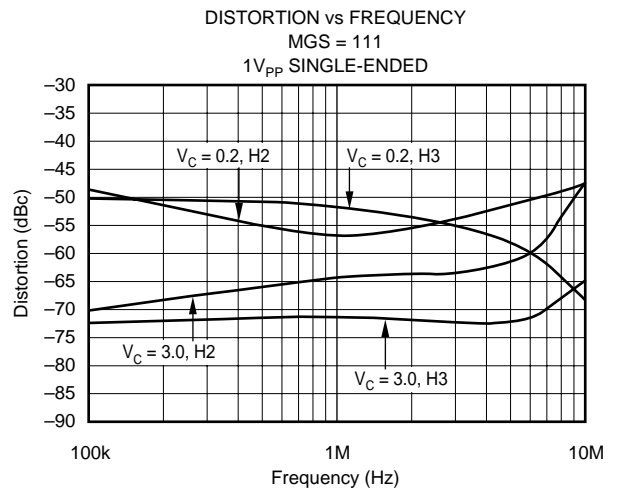
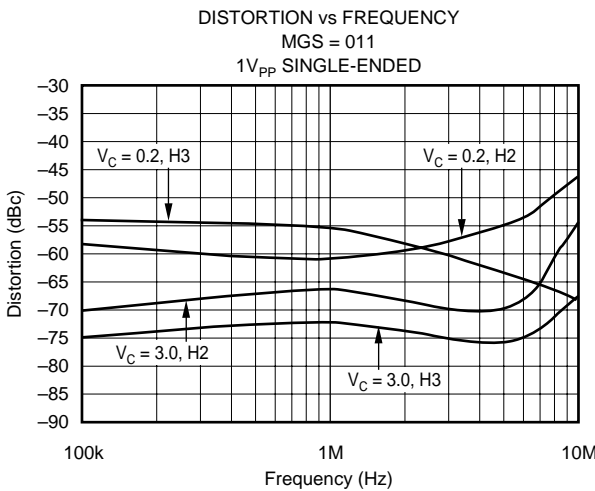
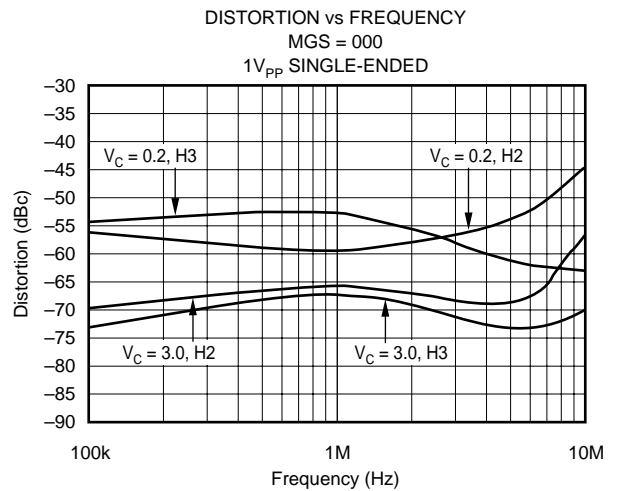
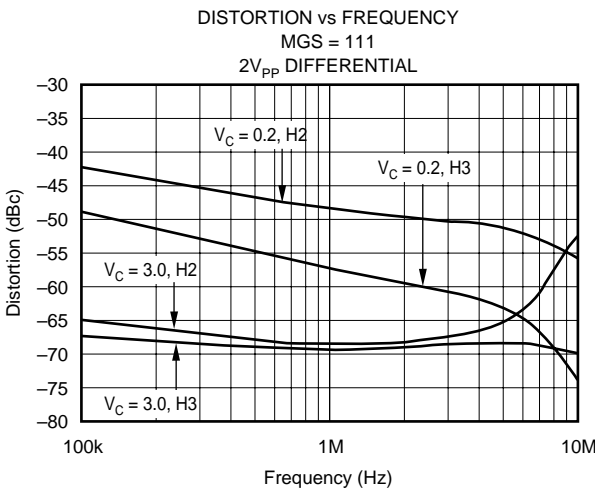

# TYPICAL CHARACTERISTICS (Cont.)

At  $T_A = +25^\circ\text{C}$ ,  $V_{DDA} = V_{ddb} = V_{DDR} = +5\text{V}$ , load resistance =  $500\Omega$  on each output to ground,  $\text{MGS} = 011$ ,  $\text{LNP} = 22\text{dB}$  and  $f_{IN} = 5\text{MHz}$ , unless otherwise noted. The input to the preamp (LNP) is single-ended, and the output from the VCA is single-ended, unless otherwise noted. This results in a 6dB reduction in signal amplitude compared to differential operation.

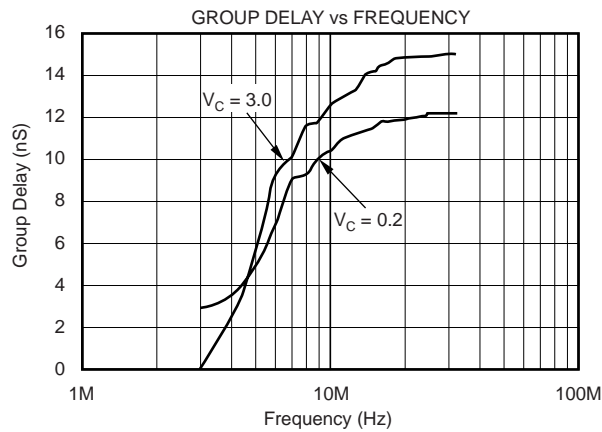
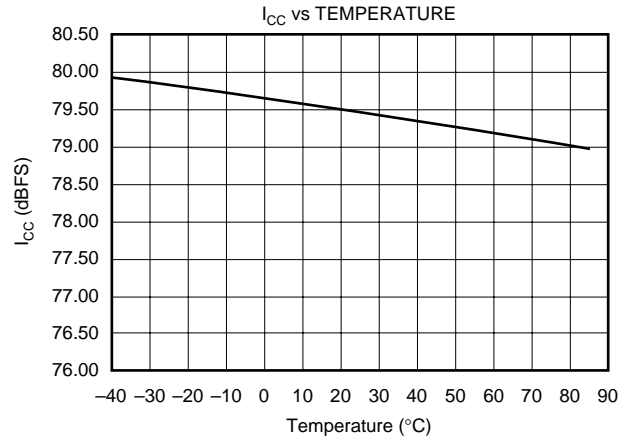
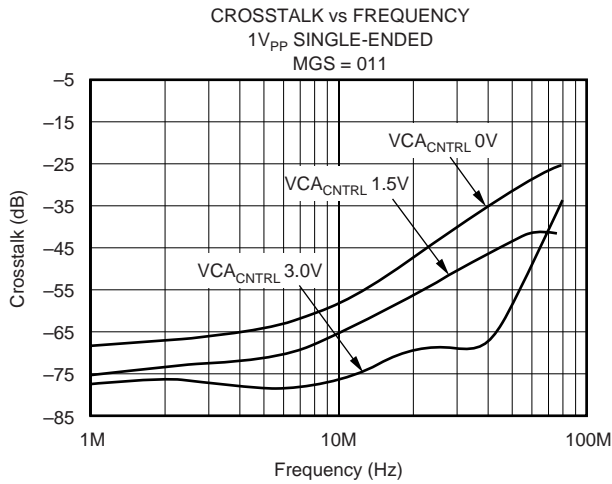

# THEORY OF OPERATION

The VCA2616 and VCA2611 are dual-channel systems consisting of three primary blocks: an LNP, a VCA, and a Programmable Gain Amplifier (PGA). For greater system flexibility, an onboard multiplexer is provided for the VCA inputs, selecting either the LNP outputs or external signal inputs. Figure 1 shows a simplified block diagram of the dual-channel system.

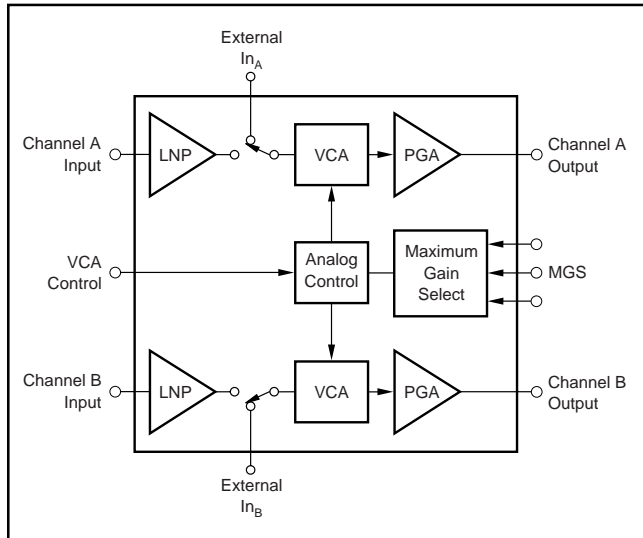

FIGURE 1. Simplified Block Diagram of the VCA2616.

## LNP—OVERVIEW

The LNP input may be connected to provide active-feedback signal termination, achieving lower system noise performance than conventional passive shunt termination. Further lower noise performance is obtained if signal termination is not required. The unterminated LNP input impedance is 600k $\Omega$ . The LNP can process fully differential or single-ended signals in each channel. Differential signal processing results in significantly reduced 2nd-harmonic distortion and improved rejection of common-mode and power-supply noise. The first gain stage of the LNP is AC-coupled into its output buffer with a 4.8 $\mu$ s time constant (33kHz high-pass characteristic). The buffered LNP outputs are designed to drive the succeeding VCA directly or, if desired, external loads as low as 135 $\Omega$  with minimal impact on signal distortion. The LNP employs very low impedance local feedback to achieve stable gain with the lowest possible noise and distortion. Four pin-programmable gain settings are available: 5dB, 17dB, 22dB, and 25dB. Additional intermediate gains can be programmed by adding trim resistors between the Gain Strap programming pins.

The common-mode DC level at the LNP output is nominally 2.5V, matching the input common-mode requirement of the VCA for simple direct coupling. When external signals are fed to the VCA, they should also be set up with a 2.5V<sub>DC</sub> common-mode level. Figure 2 shows a circuit that demonstrates the recommended coupling method using an external

op amp. The  $V_{CM}$  node shown in Figure 2 is the  $V_{CM}$  output (pin 19). Typical R and C values are shown, yielding a high-pass time constant similar to that of the LNP. If a different common-mode referencing method is used, it is important that the common-mode level be within 10mV of the  $V_{CM}$  output for proper operation.

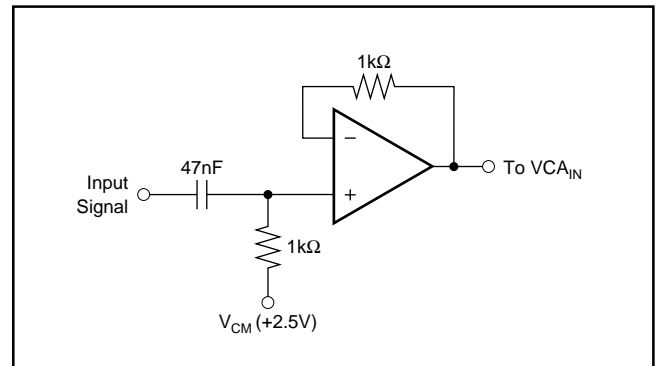

FIGURE 2. Recommended Circuit for Coupling an External Signal into the VCA Inputs.

## VCA—OVERVIEW

The magnitude of the differential VCA input signal (from the LNP or an external source) is reduced by a programmable attenuation factor, set by the analog VCA Control Voltage ( $V_{CA\_CNTL}$ ) at pin 43. The maximum attenuation factor is further programmable by using the three MGS bits (pins 40-42). Figure 3 illustrates this dual-adjustable characteristic. Internally, the signal is attenuated by having the analog  $V_{CA\_CNTL}$  vary the channel resistance of a set of shunt-connected FET transistors. The MGS bits effectively adjust the overall size of the shunt FET by switching parallel components in or out under logic control. At any given maximum gain setting, the analog variable gain characteristic is linear in dB as a function of the control voltage, and is created as a piecewise approximation of an ideal dB-linear transfer function. The VCA gain control circuitry is common to both channels of the VCA2616 and VCA2611.

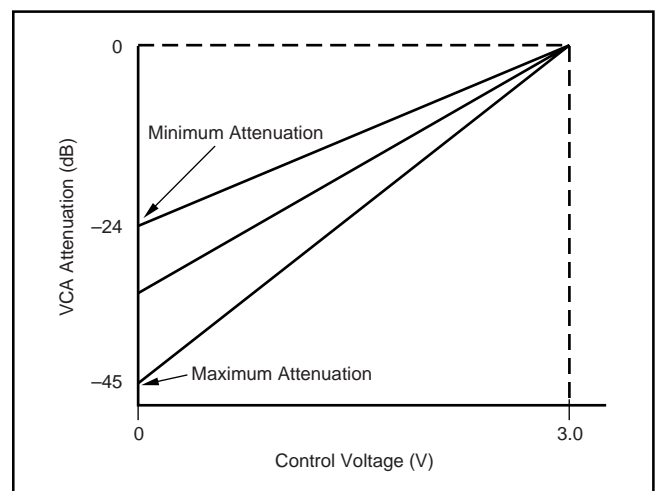

FIGURE 3. Swept Attenuator Characteristic.



where  $R_L$  is the load resistor in the drains of  $Q_3$  and  $Q_8$ , and  $R_S$  is the resistor connected between the sources of the input transistors  $Q_4$  and  $Q_7$ . The connections for various  $R_S$  combinations are brought out to device pins  $\text{LNPG}_{S1}$ ,  $\text{LNPG}_{S2}$ , and  $\text{LNPG}_{S3}$  (pins 13-15 for channel A, 22-24 for channel B). These Gain Strap pins allow the user to establish one of four fixed LNP gain options as shown in Table I.

LNP PIN STRAPPING	LNP GAIN (dB)
$\text{LNPG}_{S1}$ , $\text{LNPG}_{S2}$ , $\text{LNPG}_{S3}$ Connected Together	25
$\text{LNPG}_{S1}$ Connected to $\text{LNPG}_{S3}$	22
$\text{LNPG}_{S1}$ Connected to $\text{LNPG}_{S2}$	17
All Pins Open	5

TABLE I. Pin Strappings of the LNP for Various Gains.

It is also possible to create other gain settings by connecting an external resistor between  $\text{LNPG}_{S1}$  on one side, and  $\text{LNPG}_{S2}$  and/or  $\text{LNPG}_{S3}$  on the other. In that case, the internal resistor values (see Figure 4) should be combined with the external resistor to calculate the effective value of  $R_S$  for use in Equation 1. The resulting expression for external resistor value is given in Equation 2:

$$R_{\text{EXT}} = \frac{2R_{S1}R_L + 2R_{\text{FIX}}R_L - \text{Gain} \times R_{S1}R_{\text{FIX}}}{\text{Gain} \times R_{S1} - 2R_L} \quad (2)$$

where  $R_{\text{EXT}}$  is the externally selected resistor value needed to achieve the desired gain setting,  $R_{S1}$  is the fixed parallel resistor in Figure 4, and  $R_{\text{FIX}}$  is the effective fixed value of the remaining internal resistors:  $R_{S2}$ ,  $R_{S3}$ , or  $(R_{S2} \parallel R_{S3})$ , depending on the pin connections.

Note that the best process and temperature stability will be achieved by using the pre-programmed fixed-gain options of Table I, since the gain is then set entirely by internal resistor ratios, which are typically accurate to  $\pm 0.5\%$ , and track quite well over process and temperature. When combining external resistors with the internal values to create an effective  $R_S$  value, note that the internal resistors have a typical temperature coefficient of  $+700\text{ppm}/^\circ\text{C}$  and an absolute value tolerance of approximately  $\pm 5\%$ , yielding somewhat less predictable and stable gain settings. With or without external resistors, the board layout should use short Gain Strap connections to minimize parasitic resistance and inductance effects. The overall noise performance of the VCA2616 and VCA2611 will vary as a function of gain. Table II shows the typical input-and-output-referred noise densities of the entire VCA2616 and VCA2611 for maximum VCA and PGA gain; that is,  $\text{VCA}_{\text{CNTL}}$  set to 3.0V and all MGS bits set to 1. Note that the input-referred noise values include the contribution of a  $50\Omega$  fixed source impedance, and are therefore somewhat larger than the intrinsic input noise. As the LNP gain is reduced, the noise contribution from the VCA/PGA portion becomes more significant, resulting in higher input-referred noise. However, the output-referred noise, which is indicative of the overall SNR at that gain setting, is reduced.

To preserve the low-noise performance of the LNP, the user should take care to minimize resistance in the input lead. A parasitic resistance of only  $10\Omega$  will contribute  $0.4\text{nV}/\sqrt{\text{Hz}}$ .

LNP GAIN (dB)	NOISE ( $\text{nV}/\sqrt{\text{Hz}}$ )	
	Input-Referred	Output-Referred
25	1.35	2260
22	1.41	1650
17	1.63	1060
5	4.28	597

TABLE II. Equivalent Noise Performance for  $\text{MGS} = 111$  and  $\text{VCA}_{\text{CNTL}} = 3.0\text{V}$  with  $50\Omega$  source impedance.

The LNP is capable of generating a  $2V_{\text{PP}}$  differential signal. The maximum signal at the LNP input is therefore  $2V_{\text{PP}}$  divided by the LNP gain. An input signal greater than this would exceed the linear range of the LNP, an especially important consideration at low LNP gain settings.

The VCA2611 is an upgraded version of the VCA2616. The only difference between the VCA2616 and the VCA2611 is the input structure to the LNP. The VCA2616 is limited to  $-0.3\text{V}$  negative-going input spikes; the VCA2611 is limited to  $-2.0\text{V}$  negative-going input spikes. This change allows the user to use slower and less expensive input clamping diodes prior to the LNA input. In some designs, input clamping may not be required.

## ACTIVE FEEDBACK WITH THE LNP

One of the key features of the LNP architecture is the ability to employ active-feedback termination to achieve superior noise performance. Active-feedback termination achieves a lower noise figure than conventional shunt termination, essentially because no signal current is wasted in the termination resistor itself. Another way to understand this is to consider first that the input source, at the far end of the signal cable, has a cable-matching source resistance of  $R_S$ . Using conventional shunt termination at the LNP input, a second terminating resistor of value  $R_S$  is connected to ground. Therefore, the signal loss is 6dB due to the voltage divider action of the series and shunt  $R_S$  resistors. The effective source resistance has been reduced by the same factor of 2, but the noise contribution has been reduced by only the  $\sqrt{2}$ , only a 3dB reduction. Therefore, the net theoretical SNR degradation is 3dB, assuming a noise-free amplifier input. (In practice, the amplifier noise contribution will degrade both the unterminated and the terminated noise figures, somewhat reducing the distinction between them.)

See Figure 5 for an amplifier using active feedback. This diagram appears very similar to a traditional inverting amplifier. However, the analysis is somewhat different because the gain  $A$  in this case is not a very large open-loop op amp gain; rather, it is the relatively low and controlled gain of the LNP itself. Thus, the impedance at the inverting amplifier terminal will be reduced by a finite amount, as given in the familiar relationship of Equation 3:

$$R_{\text{IN}} = \frac{R_F}{(1+A)} \quad (3)$$

where  $R_F$  is the feedback resistor (supplied externally between the  $\text{LNP}_{\text{INP}}$  and FB terminals for each channel),  $A$  is

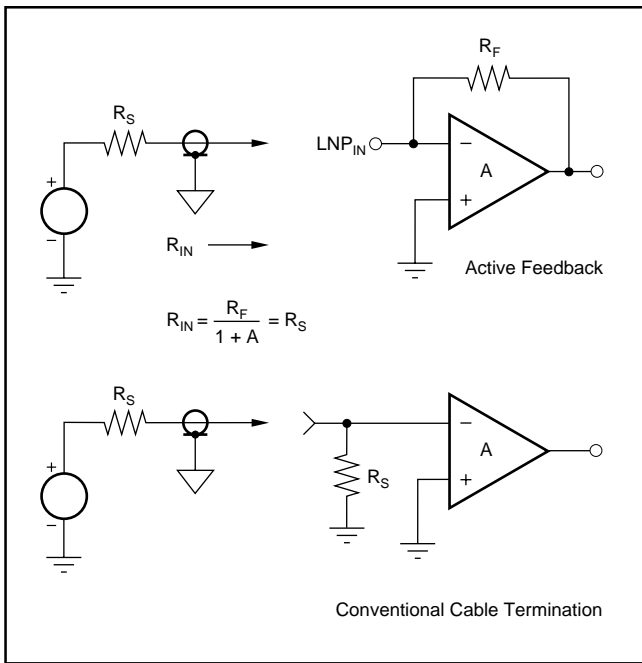

FIGURE 5. Configurations for Active Feedback and Conventional Cable Termination.

the user-selected gain of the LNP, and  $R_{IN}$  is the resulting amplifier input impedance with active feedback. In this case, unlike the conventional termination above, both the signal voltage and the  $R_S$  noise are attenuated by the same factor of 2 (6dB) before being re-amplified by the A gain setting. This avoids the extra 3dB degradation due to the square-root effect described earlier, the key advantage of the active termination technique.

This previous explanation ignored the input noise contribution of the LNP itself. Also, the noise contribution of the feedback resistor must be included for a completely correct analysis. The curves given in Figures 6 and 7 allow the VCA2616 and VCA2611 user to compare the achievable

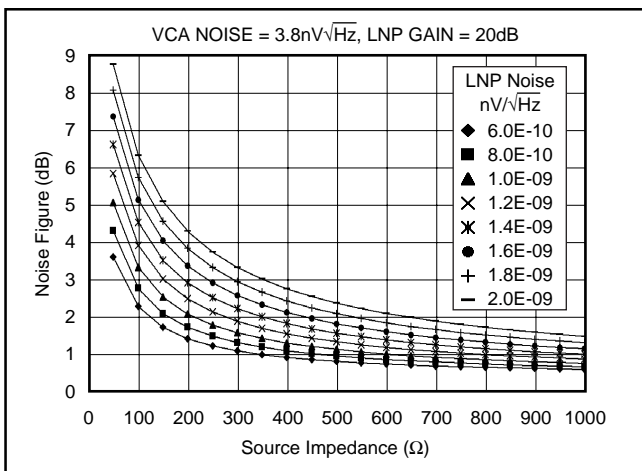

FIGURE 6. Noise Figure for Active Termination.

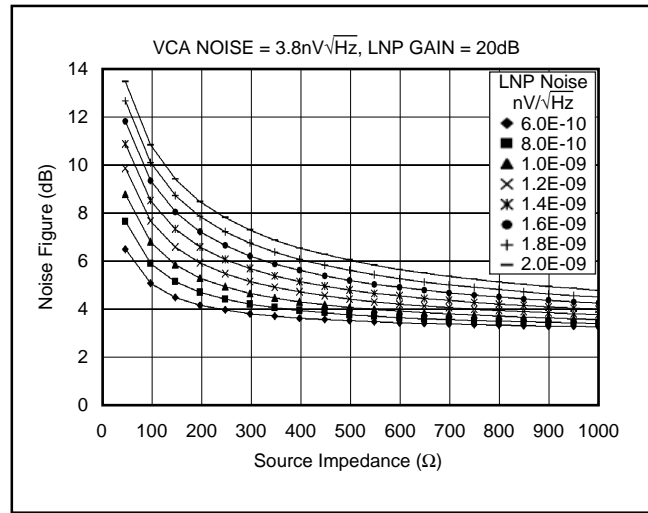

FIGURE 7. Noise Figure for Conventional Termination.

noise figure for active and conventional termination methods. The left-most set of data points in each graph give the results for typical 50Ω cable termination, showing the worst noise figure but also the greatest advantage of the active feedback method.

A switch, controlled by the  $FBSW_{CNTL}$  signal on pin 45, enables the user to reduce the feedback resistance by adding an additional parallel component, connected between the  $LNP_{IN,P}$  and  $SWFB$  terminals. The two different values of feedback resistance will result in two different values of active-feedback input resistance. Thus, the active-feedback impedance can be optimized at two different LNP gain settings. The switch is connected at the buffered output of the LNP and has an ON resistance of approximately 1Ω.

When employing active feedback, the user should be careful to avoid low-frequency instability or overload problems. Figure 8 illustrates the various low-frequency time constants.

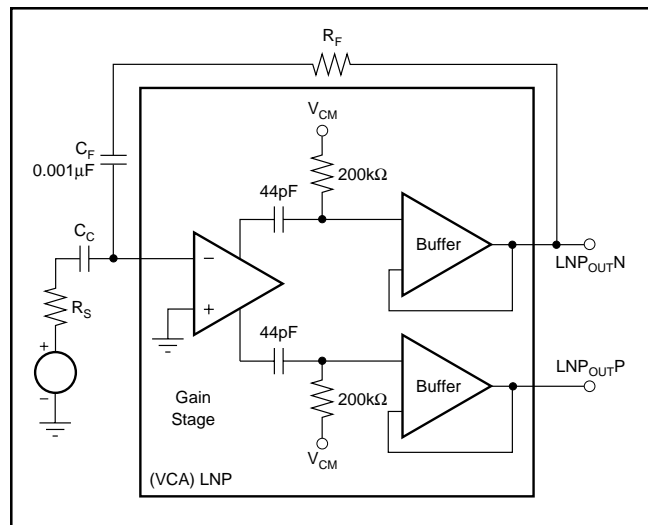

FIGURE 8. Low-Frequency LNP Time Constants.

Referring again to the input resistance calculation of Equation (3), and considering that the gain term “A” falls off below 21kHz, it is evident that the effective LNP input impedance will rise below 3.6kHz, with a DC limit of approximately  $R_F$ . To avoid interaction with the feedback pole/zero at low frequencies, and to avoid the higher signal levels resulting from the rising impedance characteristic, it is recommended that the external  $R_F C_C$  time constant be set to about 5 $\mu$ s.

Achieving the best active-feedback architecture is difficult with conventional op amp circuit structures. The overall gain A must be negative in order to close the feedback loop, the input impedance must be high to maintain low current noise and good gain accuracy, but the gain ratio must be set with very low value resistors to maintain good voltage noise. Using a two-amplifier configuration (noninverting for high impedance plus inverting for negative feedback reasons) results in excessive phase lag and stability problems when the loop is closed. The VCA2616 and VCA2611 use a patented architecture that achieves these requirements, with the additional benefits of low power dissipation and differential signal handling at both input and output.

For greatest flexibility and lowest noise, the user may wish to shape the frequency response of the LNP. The COMP1 and COMP2 pins for each channel (pins 10 and 11 for channel A, pins 26 and 27 for channel B) correspond to the drains of  $Q_3$  and  $Q_8$ , see Figure 4. A capacitor placed between these pins will create a single-pole low-pass response, in which the effective R of the RC time constant is approximately 186 $\Omega$ .

### COMPENSATION WHEN USING ACTIVE FEEDBACK

The typical open-loop gain versus frequency characteristic for the LNP is shown in Figure 9. The -3dB bandwidth is approximately 180MHz and the phase response is such that when feedback is applied, the LNP will exhibit a peaked response or might even oscillate. One method for compensating for this undesirable behavior is to place a compensation capacitor at the input to the LNP, as shown in Figure 10. This method is effective when the desired -3dB bandwidth is much less than the open-loop bandwidth of the LNP. This compensation technique also allows the total compensation capacitor to include any stray or cable capacitance that is associated with the input connection. Equation 4 relates the bandwidth to the various impedances that are connected to the LNP.

$$BW = \frac{(A + 1)R_i + R_F}{2\pi C(R_i)(R_F)} \quad (4)$$

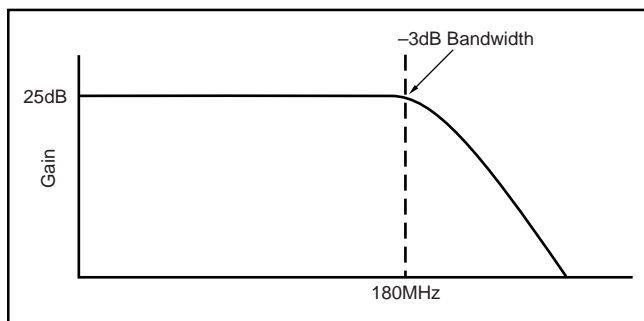

FIGURE 9. Open-Loop Gain Characteristic of LNP.

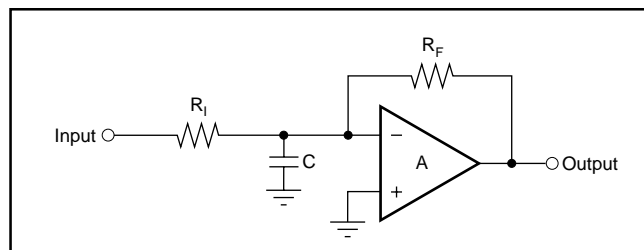

FIGURE 10. LNP with Compensation Capacitor.

### AVOIDING UNSTABLE PERFORMANCE

The VCA2612 and the VCA2616 are very similar in performance in all respects, except in the area of noise performance. See Figure 4 for a schematic of the LNP. This brings the input noise of the VCA2616 and VCA2611 down to 1.0nV/ $\sqrt{\text{Hz}}$  compared to the input on the VCA2612 1.25nV/ $\sqrt{\text{Hz}}$  impedance at the gate of either  $Q_4$  or  $Q_7$ , as can be approximated by the network shown in Figure 11. The resistive component shown in Figure 11 is negative, which gives rise to unstable behavior when the signal source resistance has both inductive and capacitive elements. It should be noted that this negative resistance is not a physical resistor, but an equivalent resistance that is a function of the devices shown in Figure 4. Normally, when an inductor and capacitor are placed in series or parallel, there is a positive resistance in the loop that prevents unstable behavior.

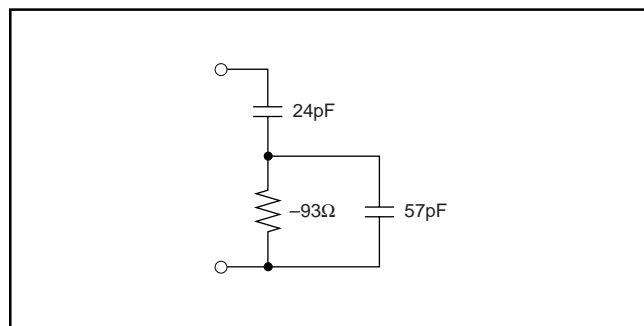

FIGURE 11. VCA2616 and VCA2611 Input Impedance.

For the VCA2616 and VCA2611, the situation can be remedied by placing an external resistor with a value of approximately 15 $\Omega$  or higher in series with the input lead. The net series resistance will be positive, and there will be no observed instability.

Although this technique will prevent oscillations, it is not recommended, as it will also increase the input noise. The preferred technique is to place an external capacitor between pins COMP2A (pin 11) and LNP<sub>IN</sub>PA (pin 16), and between pins COMP2B (pin 26) and LNP<sub>IN</sub>PB (pin 21). This has the effect of making the input impedance always capacitive due to the feedback effect of the compensation capacitor and the gain of the LNP. Using capacitive feedback, the LNP becomes unconditionally stable, as there is no longer a negative component to the input impedance. The compensation capacitor mentioned above will be reflected to the input by the formula:

$$C_{IN} = (A + 1)C_{COMP} \quad (5)$$

The capacitance that is determined in Equation 5 should be added to the capacitance of Equation 4 to determine the overall bandwidth of the LNP. The LNP<sub>IN</sub>NA (pin 12) and the LNP<sub>IN</sub>NB (pin 25) should be bypassed to ground by the shortest means possible to avoid any inductance in the lead.

## LNP OUTPUT BUFFER

The differential LNP output is buffered by wideband class AB voltage followers which are designed to drive low impedance loads. This is necessary to maintain LNP gain accuracy, since the VCA input exhibits gain-dependent input impedance. The buffers are also useful when the LNP output is brought out to drive external filters or other signal processing circuitry. Good distortion performance is maintained with buffer loads as low as 135Ω. As mentioned previously, the buffer inputs are AC-coupled to the LNP outputs with a 3.6kHz high-pass characteristic, and the DC common-mode level is maintained at the correct  $V_{CM}$  for compatibility with the VCA input.

## VOLTAGE-CONTROLLED ATTENUATOR (VCA)—DETAIL

The VCA is designed to have a dB-linear attenuation characteristic; that is, the gain loss in dB is constant for each equal increment of the  $V_{CA\_CNTL}$  control voltage. See Figure 1 for a block diagram of the VCA. The attenuator is essentially a variable voltage divider consisting of one series input resistor,  $R_S$ , and ten identical shunt FETs, placed in parallel and controlled by sequentially activated clipping amplifiers. Each clipping amplifier can be thought of as a specialized voltage comparator with a soft transfer characteristic and well-controlled output limit voltages. The reference voltages V1 through V10 are equally spaced over the 0V to 3.0V control voltage range. As the control voltage rises through the input range of each clipping amplifier, the amplifier output will rise from 0V (FET completely ON) to  $V_{CM} - V_T$  (FET nearly OFF), where  $V_{CM}$  is the common source voltage and  $V_T$  is the threshold voltage of the FET. As each FET approaches its OFF state and the control voltage continues to rise, the next clipping amplifier/FET combination takes over for the next portion of the piecewise-linear attenuation characteristic. Thus, low control voltages have most of the FETs turned ON, while high control voltages have most turned OFF. Each FET acts to decrease the shunt resistance of the voltage divider formed by  $R_S$  and the parallel FET network.

The attenuator is comprised of two sections, with five parallel clipping amplifier/FET combinations in each. Special reference circuitry is provided so that the  $(V_{CM} - V_T)$  limit voltage will track temperature and IC process variations, minimizing the effects on the attenuator control characteristic.

In addition to the analog  $V_{CA\_CNTL}$  gain setting input, the attenuator architecture provides digitally programmable adjustment in eight steps, via the three MGS bits. These adjust the maximum achievable gain (corresponding to minimum attenuation in the VCA, with  $V_{CA\_CNTL} = 3.0V$ ) in 3dB increments. This function is accomplished by providing multiple FET sub-elements for each of the  $Q_1$  to  $Q_{10}$  FET shunt elements (see Figure 12). In the simplified diagram of Figure 13, each shunt FET is shown as two sub-elements,  $Q_{NA}$  and  $Q_{NB}$ . Selector switches, driven by the MGS bits, activate either or both of the sub-element FETs to adjust the maximum  $R_{ON}$  and thus achieve the stepped attenuation options.

The VCA can be used to process either differential or single-ended signals. Fully differential operation will reduce 2nd-harmonic distortion by about 10dB for full-scale signals.

Input impedance of the VCA will vary with gain setting, due to the changing resistances of the programmable voltage divider structure. At large attenuation factors (that is, low gain settings), the impedance will approach the series resistor value of approximately 135Ω.

As with the LNP stage, the VCA output is AC-coupled into the PGA. This means that the attenuation-dependent DC common-mode voltage will not propagate into the PGA, and so the PGA's DC output level will remain constant.

Finally, note that the  $V_{CA\_CNTL}$  input consists of FET gate inputs. This provides very high impedance and ensures that multiple VCA2616 and VCA2611 devices may be connected in parallel with no significant loading effects. The nominal voltage range for the  $V_{CA\_CNTL}$  input spans from 0V to 3V. Overdriving this input ( $\leq 5V$ ) does not affect the performance.

## INPUT OVERLOAD RECOVERY

One of the most important applications for the VCA2616 and VCA2611 is processing signals in an ultrasound system. The ultrasound signal flow begins when a large signal is applied to a transducer, which converts electrical energy to acoustic energy. It is not uncommon for the amplitude of the electrical signal that is applied to the transducer to be  $\pm 50V$  or greater.

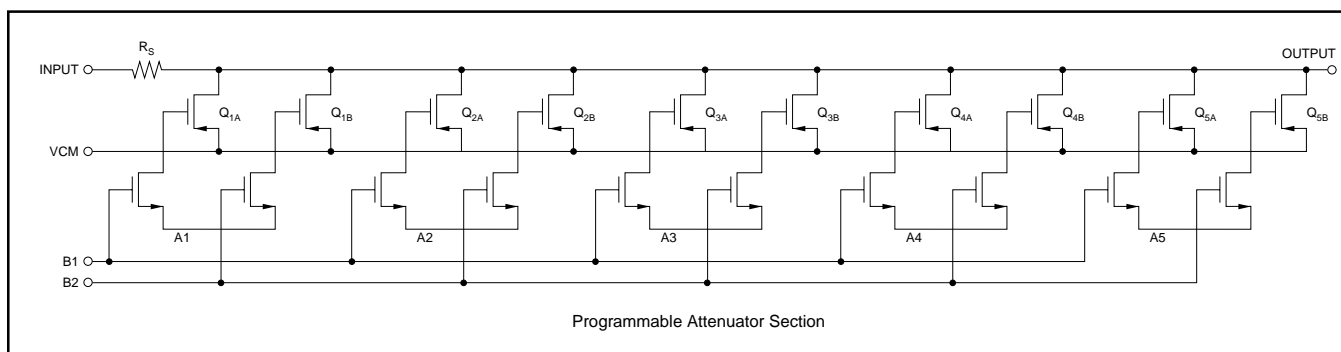

FIGURE 13. Programmable Attenuator Section.

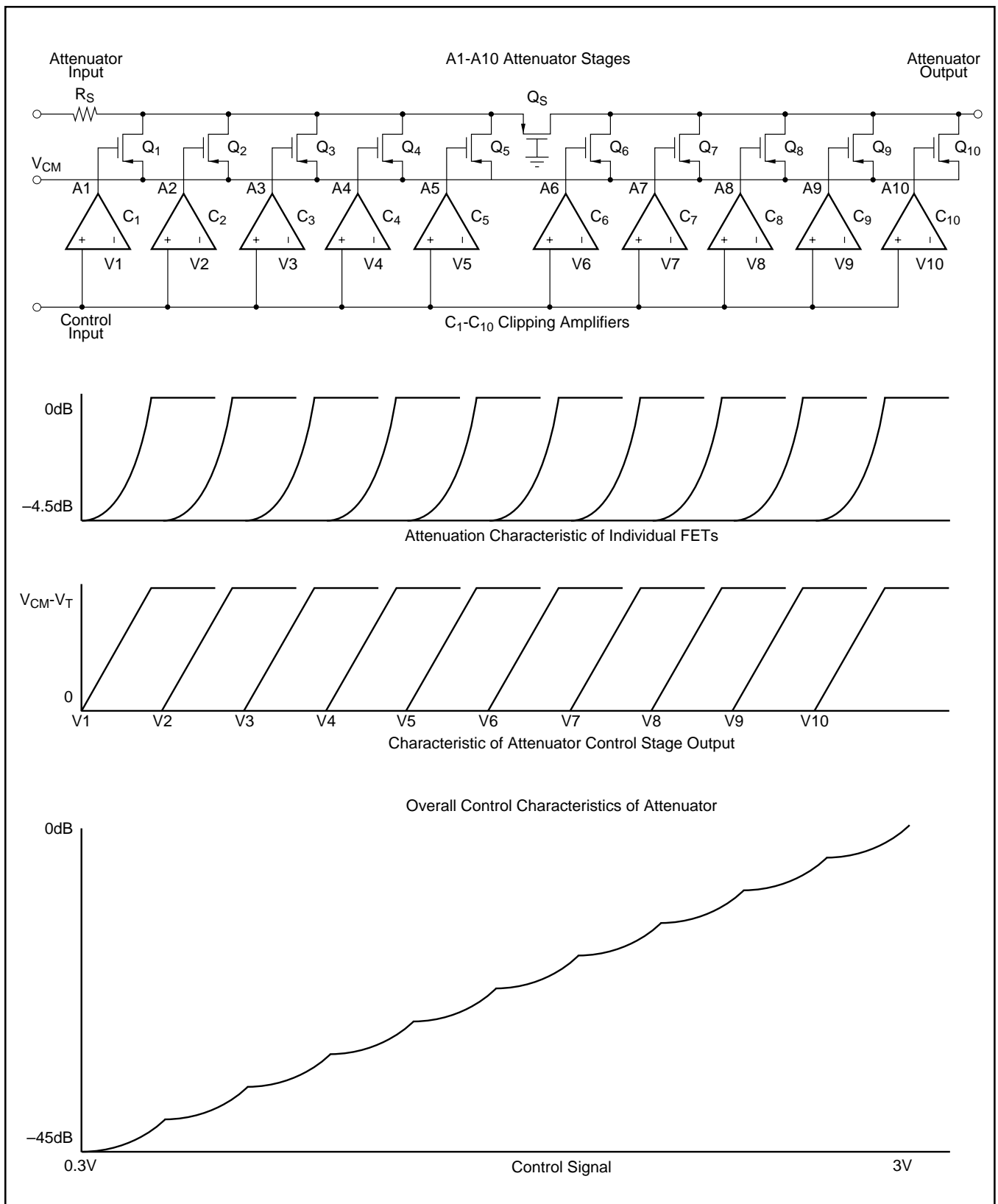

FIGURE 12. Piecewise Approximation to Logarithmic Control Characteristics.

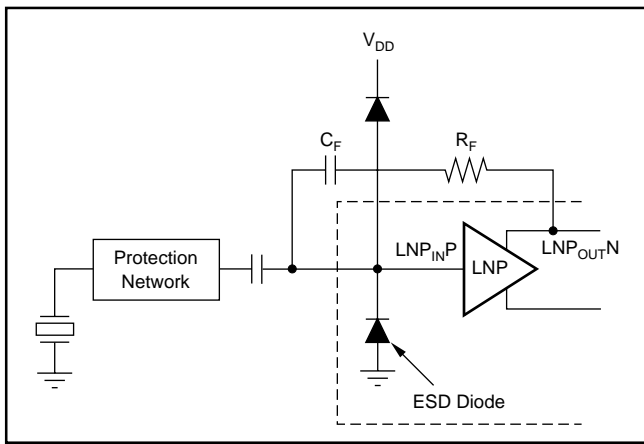

FIGURE 14. VCA2616 and VCA2611 Diode Bridge Protection Circuit.

To prevent damage, it is necessary to place a protection circuit between the transducer and the VCA2616 and VCA2611 (see Figure 14). Care must be taken to prevent any signal from turning the ESD diodes on. Turning on the ESD diodes inside the VCA2616 and VCA2611 could cause the input coupling capacitor ( $C_C$ ) to charge to the wrong value.

### PGA POST-AMPLIFIER—DETAIL

Figure 15 shows a simplified circuit diagram of the PGA block. As described previously, the PGA gain is programmed with the same MGS bits which control the VCA maximum attenuation factor. Specifically, the PGA gain at each MGS setting is the inverse (reciprocal) of the maximum VCA attenuation at that setting. Therefore, the VCA + PGA overall gain will always be 0dB (unity) when the analog  $VCA_{CNTL}$  input is set to 0V

(= maximum attenuation). For  $VCA_{CNTL} = 3V$  (no attenuation), the VCA + PGA gain will be controlled by the programmed PGA gain (24 to 45 dB in 3dB steps). For clarity, the gain and attenuation factors are detailed in Table III.

MGS SETTING	ATTENUATOR GAIN $VCA_{CNTL} = 0V$ to $3V$	DIFFERENTIAL PGA GAIN	ATTENUATOR + DIFF. PGA GAIN
000	-24dB to 0dB	24dB	0dB to 24dB
001	-27dB to 0dB	27dB	0dB to 27dB
010	-30dB to 0dB	30dB	0dB to 30dB
011	-33dB to 0dB	33dB	0dB to 33dB
100	-36dB to 0dB	36dB	0dB to 36dB
101	-39dB to 0dB	39dB	0dB to 39dB
110	-42dB to 0dB	42dB	0dB to 42dB
111	-45dB to 0dB	45dB	0dB to 45dB

TABLE III. MGS Settings.

The PGA architecture consists of a differential, programmable-gain voltage to current converter stage followed by transimpedance amplifiers to create and buffer each side of the differential output. The circuitry associated with the voltage to current converter is similar to that previously described for the LNP, with the addition of eight selectable PGA gain-setting resistor combinations (controlled by the MGS bits) in place of the fixed resistor network used in the LNP. Low input noise is also a requirement of the PGA design due to the large amount of signal attenuation which can be inserted between the LNP and the PGA. At minimum VCA attenuation (used for small input signals) the LNP noise dominates; at maximum VCA attenuation (large input signals) the PGA noise dominates. Note that if the PGA output is used single-ended, the apparent gain will be 6dB lower.

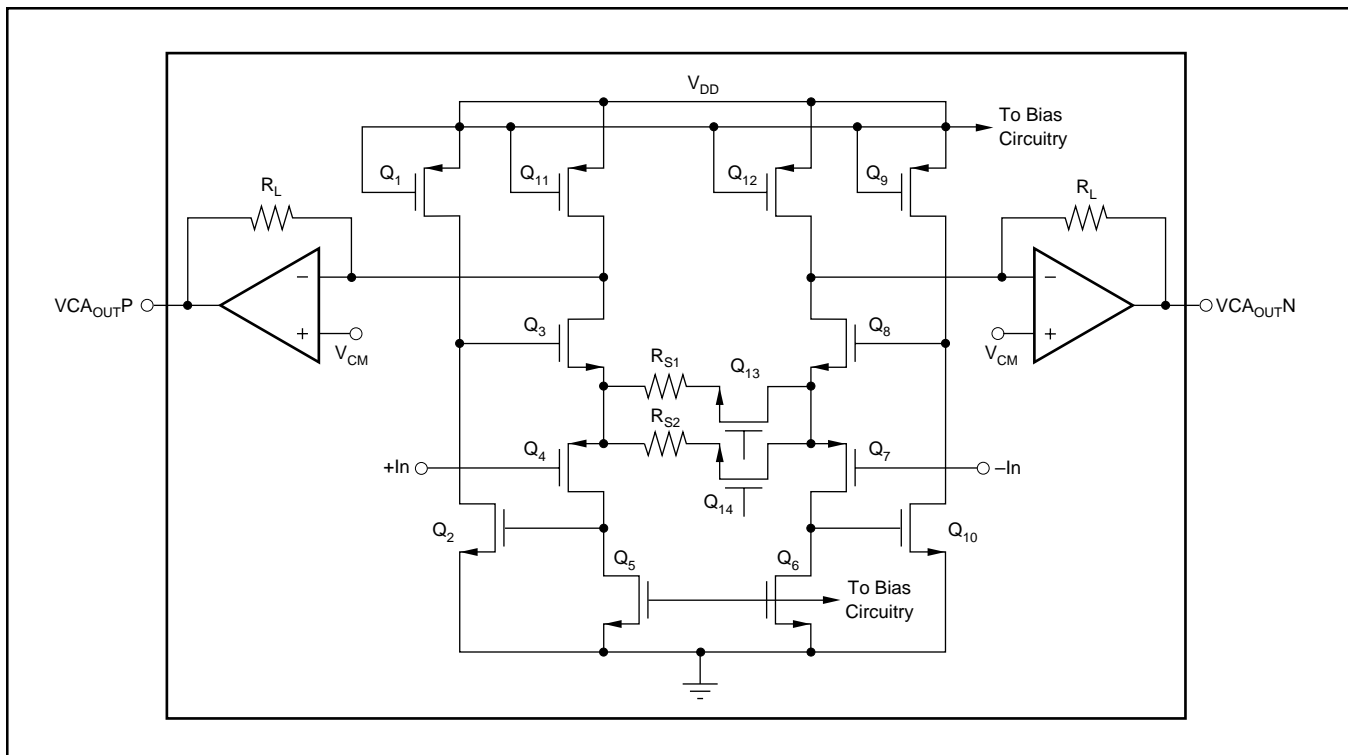

FIGURE 15. Simplified Block Diagram of the PGA Section Within the VCA2616 and VCA2611.

---

## PACKAGING INFORMATION

ORDERABLE DEVICE	STATUS(1)	PACKAGE TYPE	PACKAGE DRAWING	PINS	PACKAGE QTY
VCA2611Y/250	ACTIVE	TQFP	PFB	48	250
VCA2611Y/2K	ACTIVE	TQFP	PFB	48	2000
VCA2616YR	ACTIVE	TQFP	PFB	48	2000
VCA2616YT	ACTIVE	TQFP	PFB	48	250

(1) The marketing status values are defined as follows:

**ACTIVE:** Product device recommended for new designs.

**LIFEBUY:** TI has announced that the device will be discontinued, and a lifetime-buy period is in effect.

**NRND:** Not recommended for new designs. Device is in production to support existing customers, but TI does not recommend using this part in a new design.

**PREVIEW:** Device has been announced but is not in production. Samples may or may not be available.

**OBSOLETE:** TI has discontinued the production of the device.

---

PFB (S-PQFP-G48)

PLASTIC QUAD FLATPACK

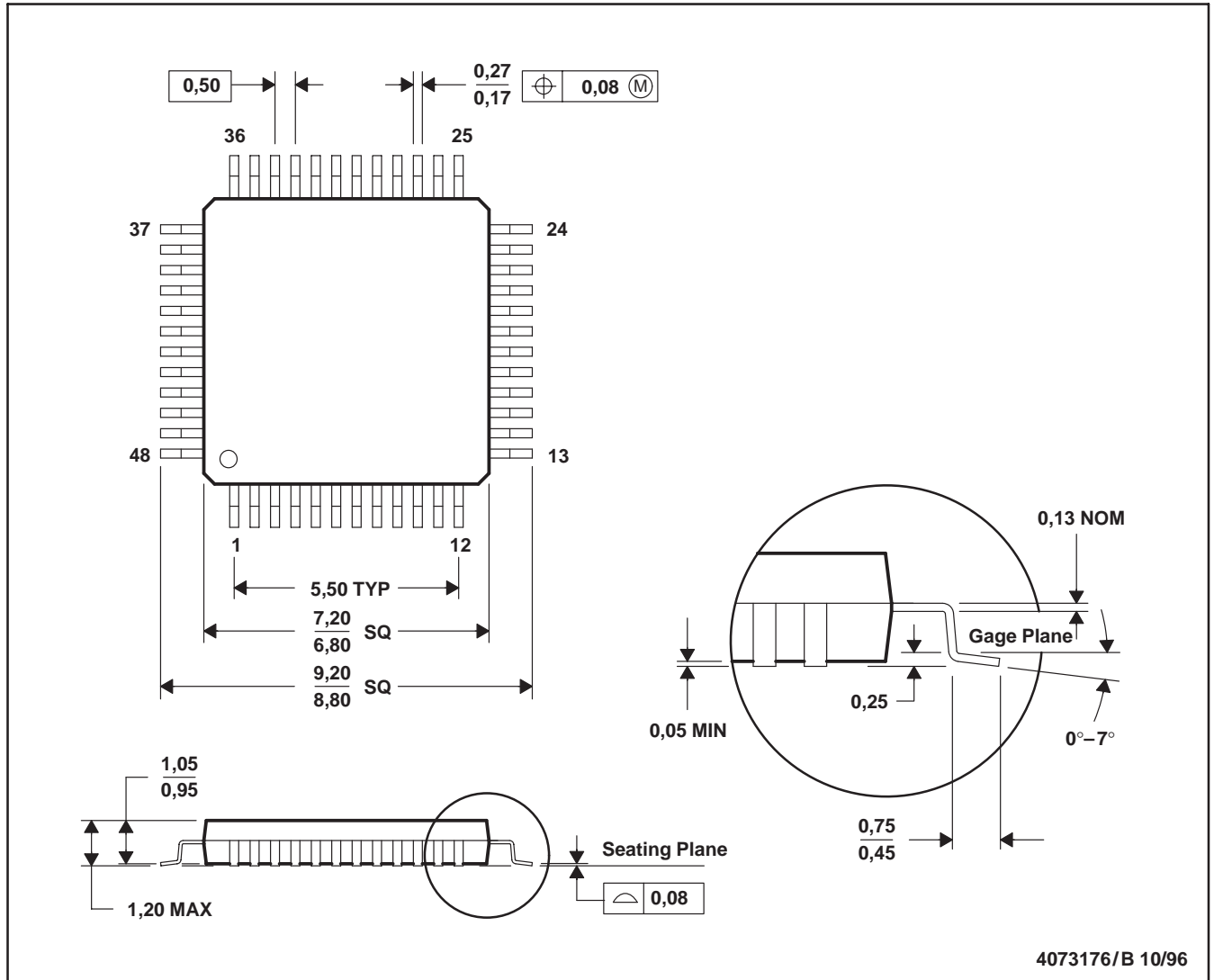

- NOTES: A. All linear dimensions are in millimeters.  
 B. This drawing is subject to change without notice.  
 C. Falls within JEDEC MS-026

## IMPORTANT NOTICE

Texas Instruments Incorporated and its subsidiaries (TI) reserve the right to make corrections, modifications, enhancements, improvements, and other changes to its products and services at any time and to discontinue any product or service without notice. Customers should obtain the latest relevant information before placing orders and should verify that such information is current and complete. All products are sold subject to TI's terms and conditions of sale supplied at the time of order acknowledgment.

TI warrants performance of its hardware products to the specifications applicable at the time of sale in accordance with TI's standard warranty. Testing and other quality control techniques are used to the extent TI deems necessary to support this warranty. Except where mandated by government requirements, testing of all parameters of each product is not necessarily performed.

TI assumes no liability for applications assistance or customer product design. Customers are responsible for their products and applications using TI components. To minimize the risks associated with customer products and applications, customers should provide adequate design and operating safeguards.

TI does not warrant or represent that any license, either express or implied, is granted under any TI patent right, copyright, mask work right, or other TI intellectual property right relating to any combination, machine, or process in which TI products or services are used. Information published by TI regarding third-party products or services does not constitute a license from TI to use such products or services or a warranty or endorsement thereof. Use of such information may require a license from a third party under the patents or other intellectual property of the third party, or a license from TI under the patents or other intellectual property of TI.

Reproduction of information in TI data books or data sheets is permissible only if reproduction is without alteration and is accompanied by all associated warranties, conditions, limitations, and notices. Reproduction of this information with alteration is an unfair and deceptive business practice. TI is not responsible or liable for such altered documentation.

Resale of TI products or services with statements different from or beyond the parameters stated by TI for that product or service voids all express and any implied warranties for the associated TI product or service and is an unfair and deceptive business practice. TI is not responsible or liable for any such statements.

Following are URLs where you can obtain information on other Texas Instruments products and application solutions:

<b>Products</b>		<b>Applications</b>	
Amplifiers	<a href="http://amplifier.ti.com">amplifier.ti.com</a>	Audio	<a href="http://www.ti.com/audio">www.ti.com/audio</a>
Data Converters	<a href="http://dataconverter.ti.com">dataconverter.ti.com</a>	Automotive	<a href="http://www.ti.com/automotive">www.ti.com/automotive</a>
DSP	<a href="http://dsp.ti.com">dsp.ti.com</a>	Broadband	<a href="http://www.ti.com/broadband">www.ti.com/broadband</a>
Interface	<a href="http://interface.ti.com">interface.ti.com</a>	Digital Control	<a href="http://www.ti.com/digitalcontrol">www.ti.com/digitalcontrol</a>
Logic	<a href="http://logic.ti.com">logic.ti.com</a>	Military	<a href="http://www.ti.com/military">www.ti.com/military</a>
Power Mgmt	<a href="http://power.ti.com">power.ti.com</a>	Optical Networking	<a href="http://www.ti.com/opticalnetwork">www.ti.com/opticalnetwork</a>
Microcontrollers	<a href="http://microcontroller.ti.com">microcontroller.ti.com</a>	Security	<a href="http://www.ti.com/security">www.ti.com/security</a>
		Telephony	<a href="http://www.ti.com/telephony">www.ti.com/telephony</a>
		Video & Imaging	<a href="http://www.ti.com/video">www.ti.com/video</a>
		Wireless	<a href="http://www.ti.com/wireless">www.ti.com/wireless</a>

Mailing Address: Texas Instruments  
Post Office Box 655303 Dallas, Texas 75265

## Looking for pricing, stock, or lifecycle information?

Click below to explore more details on WIN SOURCE:

 [View VCA2611Y/250 on WIN SOURCE](#)

 [Texas Instruments](#) Information

## Optimize Your Supply Chain with WIN SOURCE Solutions

-  Global Sourcing Solution
-  Obsolete Management
-  Cost Control Management
-  Shortage Management
-  Alternative Solution
-  Excess Inventory Management