

Dual Output Driver

FEATURES

- Dual, 1.5A Totem Pole Outputs
- 40nsec Rise and Fall into 1000pF
- Parallel or Push-Pull Operation
- Single-Ended to Push-Pull Conversion
- High-Speed, Power MOSFET Compatible
- Low Cross-Conduction Current Spike
- Analog, Latched Shutdown
- Internal Deadband Inhibit Circuit
- Low Quiescent Current
- 5 to 40V Operation
- Thermal Shutdown Protection
- 16-Pin Dual-In-Line Package
- 20-Pin Surface Mount Package

DESCRIPTION

The UC1706 family of output drivers are made with a high-speed Schottky process to interface between low-level control functions and high-power switching devices - particularly power MOSFET's. These devices implement three generalized functions as outlined below.

First: They accept a single-ended, low-current digital input of either polarity and process it to activate a pair of high-current, totem pole outputs which can source or sink up to 1.5A each.

Second: They provide an optional single-ended to push-pull conversion through the use of an internal flip-flop driven by double-pulse-suppression logic. With the flip-flop disabled, the outputs work in parallel for 3.0A capability.

Third: Protection functions are also included for pulse-by-pulse current limiting, automatic deadband control, and thermal shutdown.

These devices are available in a two-watt plastic "bat-wing" DIP for operation over a 0°C to 70°C temperature range and, with reduced power, in a hermetically sealed cerdip for -55°C to +125°C operation. Also available in surface mount Q and L packages.

TRUTH TABLE

| INV | N.I | OUT |
|-----|-----|-----|
| H | H | L |
| L | H | H |
| H | L | L |
| L | L | L |

$\overline{\text{OUT}} = \overline{\text{INV}}$ and N.I.

$\overline{\text{OUT}} = \text{INV}$ or $\overline{\text{N.I.}}$

BLOCK DIAGRAM

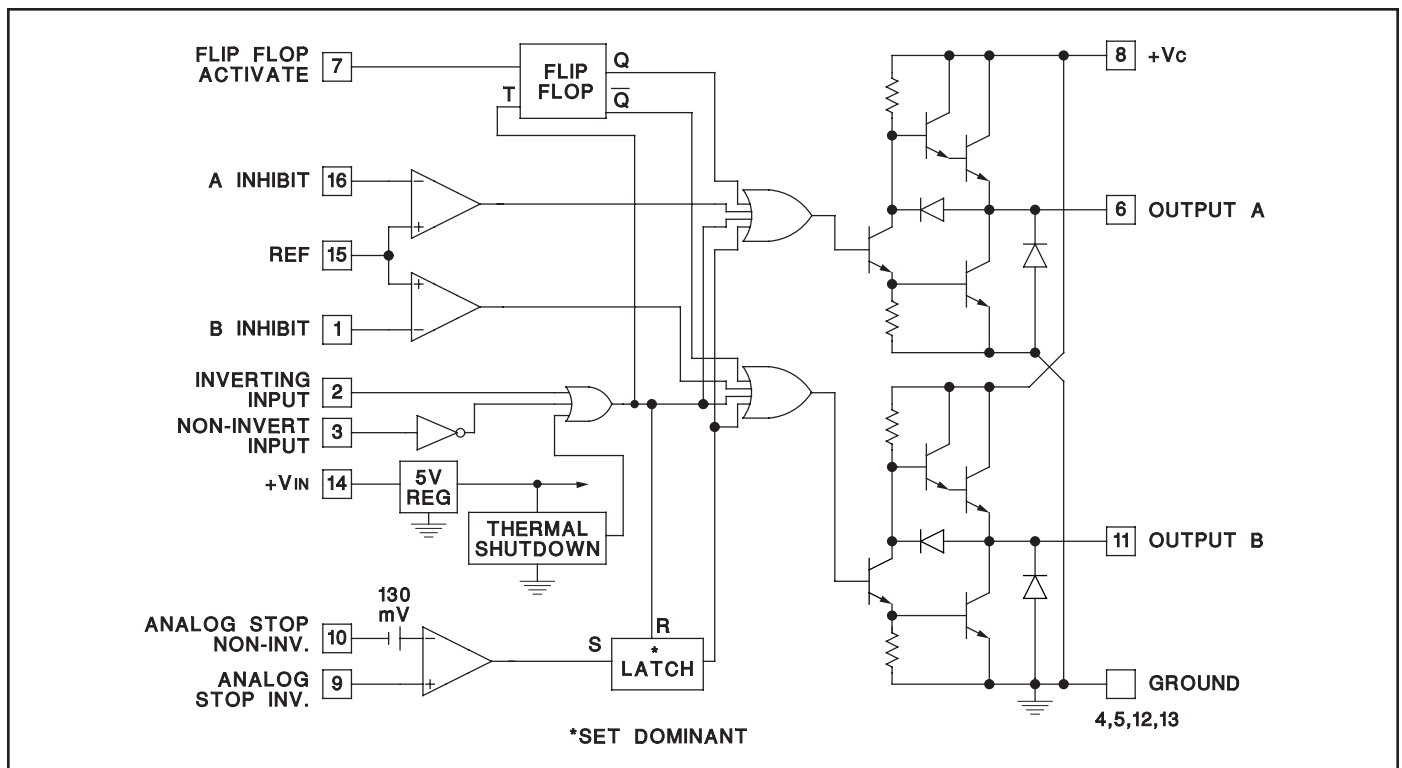

ABSOLUTE MAXIMUM RATINGS

| | N--Pkg | J--Pkg |
|---|---|--------------------|
| Supply Voltage, V_{IN} | 40V | 40V |
| Collector Supply Voltage, V_c | 40V | 40V |
| Output Current (Each Output, Source or Sink) | | |
| Steady--State | $\pm 500\text{mA}$ | $\pm 500\text{mA}$ |
| Peak Transient | $\pm 1.5\text{A}$ | $\pm 1.0\text{A}$ |
| Capacitive Discharge Energy | 20 μJ | 15 μJ |
| Digital Inputs | 5.5V | 5.5V |
| Analog Stop Inputs | V_{IN} | V_{IN} |
| Power Dissipation at $T_A = 25^\circ\text{C}$ (See Note) | 2W | 1W |
| Power Dissipation at T (Leads/Case) = 25°C (See Note) | 5W | 2 |
| Operating Temperature Range | -55°C to $+125^\circ\text{C}$ | |
| Storage Temperature Range | -65°C to $+150^\circ\text{C}$ | |
| Lead Temperature (Soldering, 10 Seconds) | 300 $^\circ\text{C}$ | |

Note: All voltages are with respect to the four ground pins which must be connected together. All currents are positive into, negative out of the specified terminal. Consult Packaging sections of the Databook for thermal limitations and considerations of package.

CONNECTION DIAGRAMS

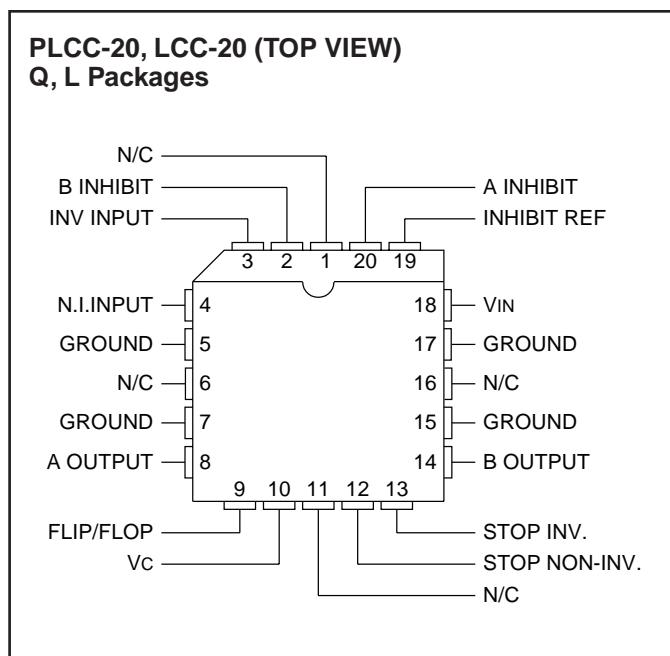
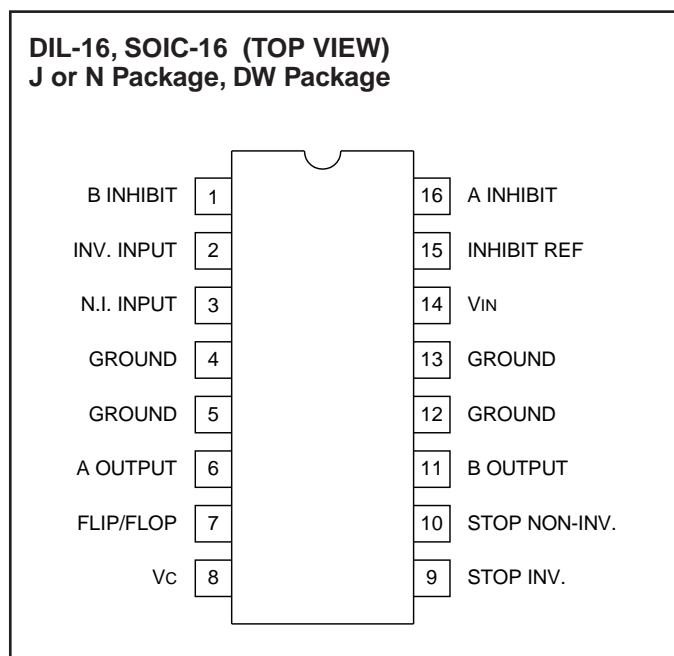

Note: All four ground pins must be connected to a common ground.

ELECTRICAL CHARACTERISTICS: Unless otherwise stated, these specifications apply for $T_A = -55^\circ\text{C}$ to $+125^\circ\text{C}$ for the UC1706, -25°C to $+85^\circ\text{C}$ for the UC2706 and 0°C to $+70^\circ\text{C}$ for the UC3706; $V_{IN} = V_c = 20\text{V}$. $T_A = T_J$.

| PARAMETERS | TEST CONDITIONS | MIN | TYP | MAX | UNITS |
|--------------------------|---|-----|------|------|-------|
| V_{IN} Supply Current | $V_{IN} = 40\text{V}$ | | 8 | 10 | mA |
| V_c Supply Current | $V_c = 40\text{V}$, Outputs Low | | 4 | 5 | mA |
| V_c Leakage Current | $V_{IN} = 0$, $V_c = 30\text{V}$, No Load | | .05 | 0.1 | mA |
| Digital Input Low Level | | | | 0.8 | V |
| Digital Input High Level | | 2.2 | | | V |
| Input Current | $V_i = 0$ | | -0.6 | -1.0 | mA |
| Input Leakage | $V_i = 5\text{V}$ | | .05 | 0.1 | mA |

ELECTRICAL CHARACTERISTICS: Unless otherwise stated, these specifications apply for $T_A = -55^{\circ}\text{C}$ to $+125^{\circ}\text{C}$ for the UC1706, -25°C to $+85^{\circ}\text{C}$ for the UC2706 and 0°C to $+70^{\circ}\text{C}$ for the UC3706; $V_{IN} = V_C = 20\text{V}$. $T_A = T_J$.

| PARAMETERS | TEST CONDITIONS | MIN | TYP | MAX | UNITS |
|-------------------------------|--|-----|-----|-----|--------------------|
| Output High Sat., $V_C - V_o$ | $I_o = -50\text{mA}$ | | | 2.0 | V |
| Output Low Sat., V_o | $I_o = 50\text{mA}$ | | | 0.4 | V |
| | $I_o = 500\text{mA}$ | | | 2.5 | V |
| Inhibit Threshold | $V_{REF} = 0.5\text{V}$ | 0.4 | | 0.6 | V |
| | $V_{REF} = 3.5\text{V}$ | 3.3 | | 3.7 | V |
| Inhibit Input Current | $V_{REF} = 0$ | | -10 | -20 | μA |
| Analog Threshold | $V_{CM} = 0$ to 15V , for the UC2706 and UC3706 | 100 | 130 | 160 | mV |
| | $V_{CM} = 0$ to 15V , for the UC1706 | 80 | 130 | 160 | mV |
| Input Bias Current | $V_{CM} = 0$ | | -10 | -20 | μA |
| Thermal Shutdown | | | 155 | | $^{\circ}\text{C}$ |

TYPICAL SWITCHING CHARACTERISTICS: $V_{IN} = V_C = 20\text{V}$, $T_A = 25^{\circ}\text{C}$. Delays measured to 10% output change.

| PARAMETERS | TEST CONDITIONS | OUTPUT $C_L =$ | | | UNITS |
|--|--|----------------|-----|-----|-------|
| | | open | 1.0 | 2.2 | |
| From Inv. Input to Output: | | | | | |
| Rise Time Delay | | 110 | 130 | 140 | ns |
| 10% to 90% Rise | | 20 | 40 | 60 | ns |
| Fall Time Delay | | 80 | 90 | 110 | ns |
| 90% to 10% Fall | | 25 | 30 | 50 | ns |
| From N. I. Input to Output: | | | | | |
| Rise Time Delay | | 120 | 130 | 140 | ns |
| 10% to 90% Rise | | 20 | 40 | 60 | ns |
| Fall Time Delay | | 100 | 120 | 130 | ns |
| 90% to 10% Fall | | 25 | 30 | 50 | ns |
| Vc Cross-Conduction Current Spike Duration | Output Rise | 25 | | | ns |
| | Output Fall | 0 | | | ns |
| Inhibit Delay | Inhibit Ref. = 1V , Inhibit Inv. = 0.5 to 1.5V | 250 | | | ns |
| Analog Shutdown Delay | Stop Non-Inv. = 0V , Stop Inv. = 0 to 0.5V | 180 | | | ns |

CIRCUIT DESCRIPTION

Outputs

The totem-pole outputs have been designed to minimize cross-conduction current spikes while maximizing fast, high-current rise and fall times. Current limiting can be done externally either at the outputs or at the common V_C pin. The output diodes included have slow recovery and should be shunted with high-speed external diodes when driving high-frequency inductive loads.

Flip/Flop

Grounding pin 7 activates the internal flip-flop to alternate the two outputs. With pin 7 open, the two outputs operate simultaneously and can be paralleled for higher current operation. Since the flip-flop is triggered by the digital input, an off-time of at least 200nsec must be provided to allow the flip/flop to change states. Note that the circuit logic is configured such that the "OFF" state is defined as the outputs low.

Digital Inputs

With both an inverting and non-inverting input available, either active-high or active-low signals may be accepted. These are true TTL compatible inputs—the threshold is approximately 1.2V with no hysteresis; and external pull-up resistors are not required.

Inhibit Circuit

Although it may have other uses, this circuit is included to eliminate the need for deadband control when driving relatively slow bipolar power transistors. A diode from each inhibit input to the opposite power switch collector will keep one output from turning-on until the other has turned-off. The threshold is determined by the voltage on pin 15 which can be set from 0.5 to 3.5V. When this circuit is not used, ground pin 15 and leave 1 and 16 open.

CIRCUIT DESCRIPTION (cont.)

Analog Shutdown

This circuit is included to get a latched shutdown as close to the outputs as possible, from a time standpoint. With an internal 130mV threshold, this comparator has a common-mode range from ground to ($V_{IN} - 3V$). When not used, both inputs should be grounded. The time required for this circuit to latch is inversely proportional to the amount of overdrive but reaches a minimum of 180nsec. As with the flip-flop, an input off-time of at least 200nsec is required to reset the latch between pulses.

Supply Voltage

With an internal 5V regulator, this circuit is optimized for

use with a 7 to 40V supply; however, with some slight response time degradation, it can also be driven from 5V. When V_{IN} is low, the entire circuit is disabled and no current is drawn from V_c . When combined with a UC1840 PWM, the Driver Bias switch can be used to supply V_{IN} to the UC1706. V_{IN} switching should be fast as if V_c is high, undefined operation of the outputs may occur with V_{IN} less than 5V.

Thermal Considerations

Should the chip temperature reach approximately 155°C, a parallel, non-inverting input is activated driving both outputs to the low state.

APPLICATIONS

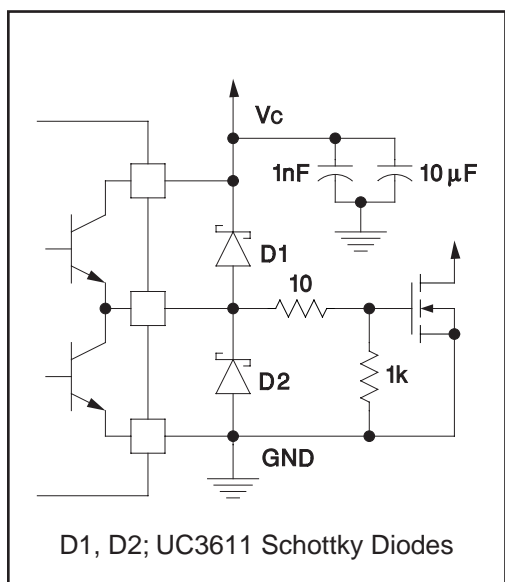

Power MOSFET Drive Circuit

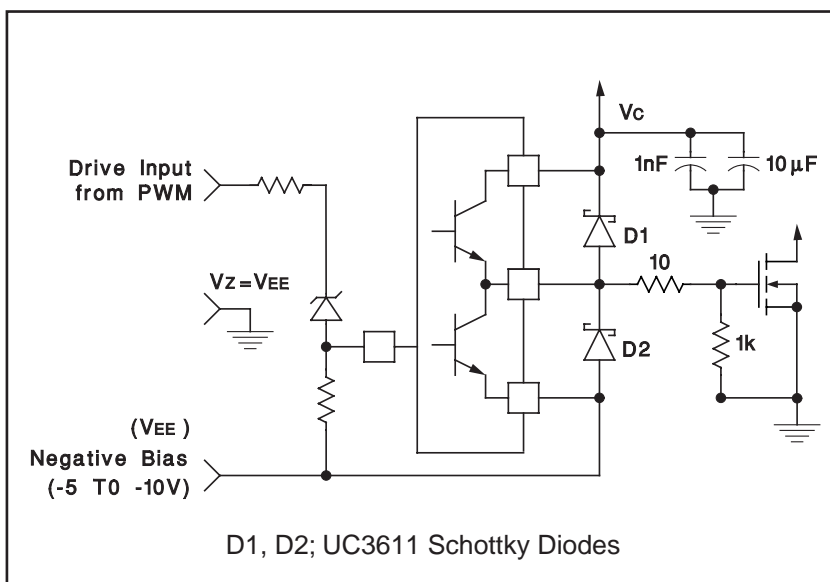

Power MOSFET Drive Circuit Using Negative Bias Voltage and Level Shifting to Ground Referenced PWMs

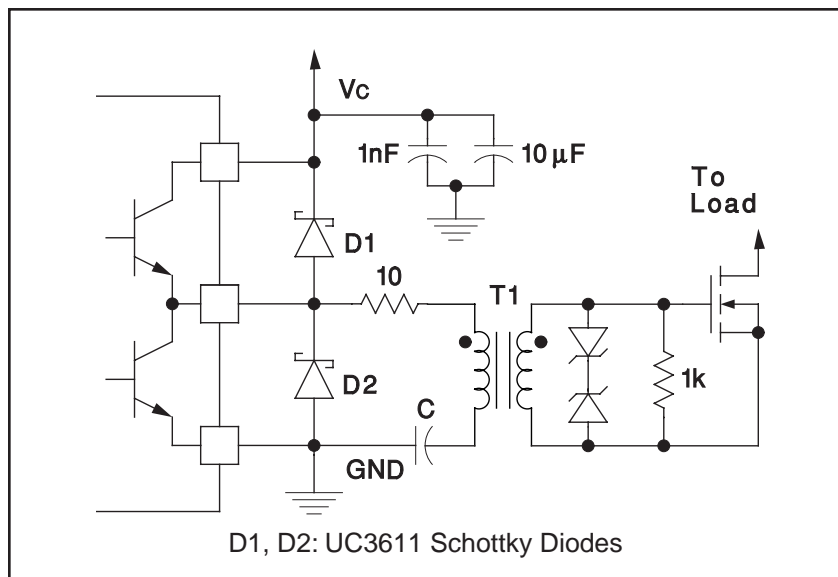

Transformer Coupled MOSFET Drive Circuit

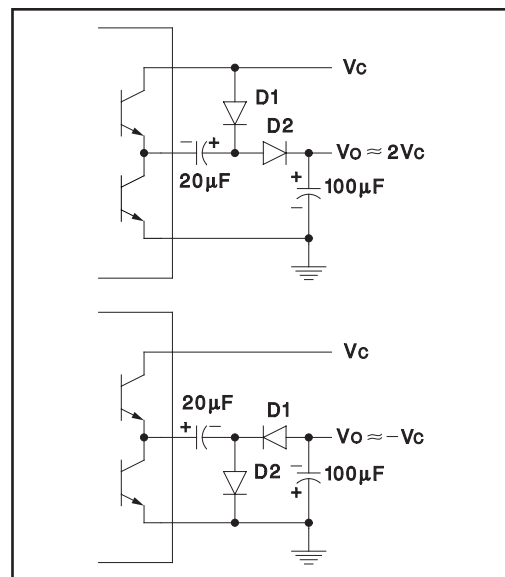

Charge Pump Circuits

APPLICATIONS (cont'd)

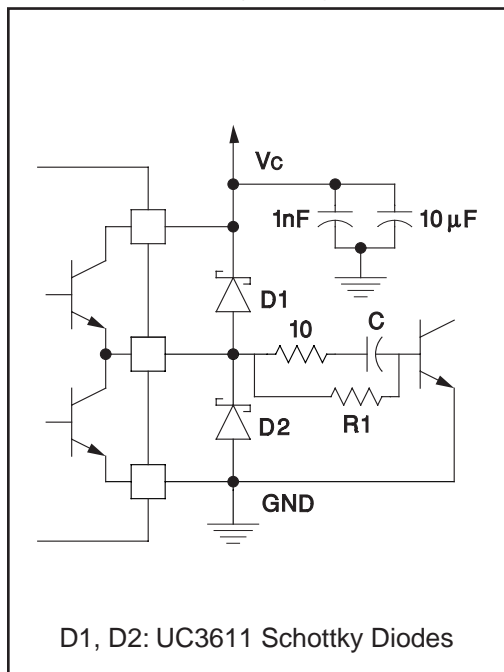

D1, D2: UC3611 Schottky Diodes

Power Bipolar Drive Circuit

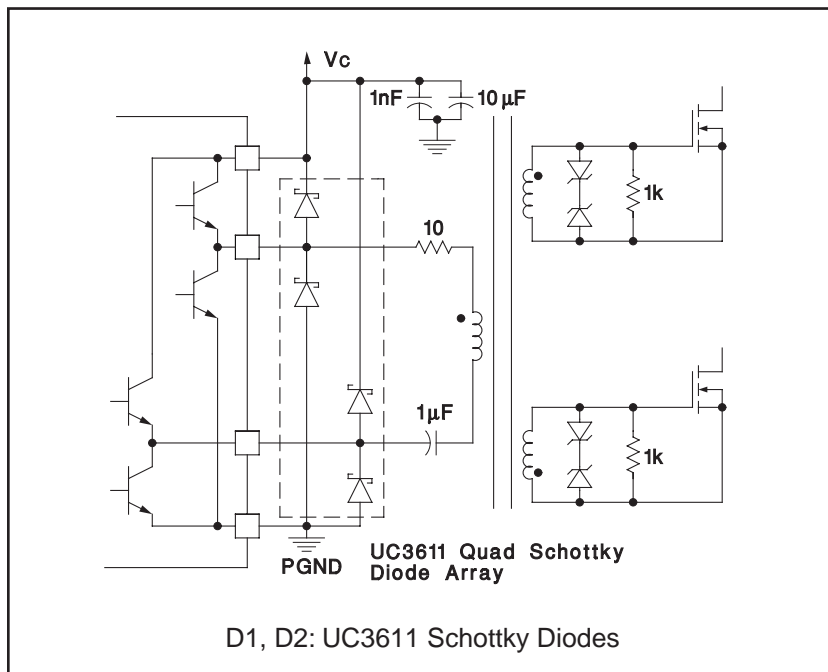

D1, D2: UC3611 Schottky Diodes

Transformer Coupled Push-Pull MOSFET Drive Circuit

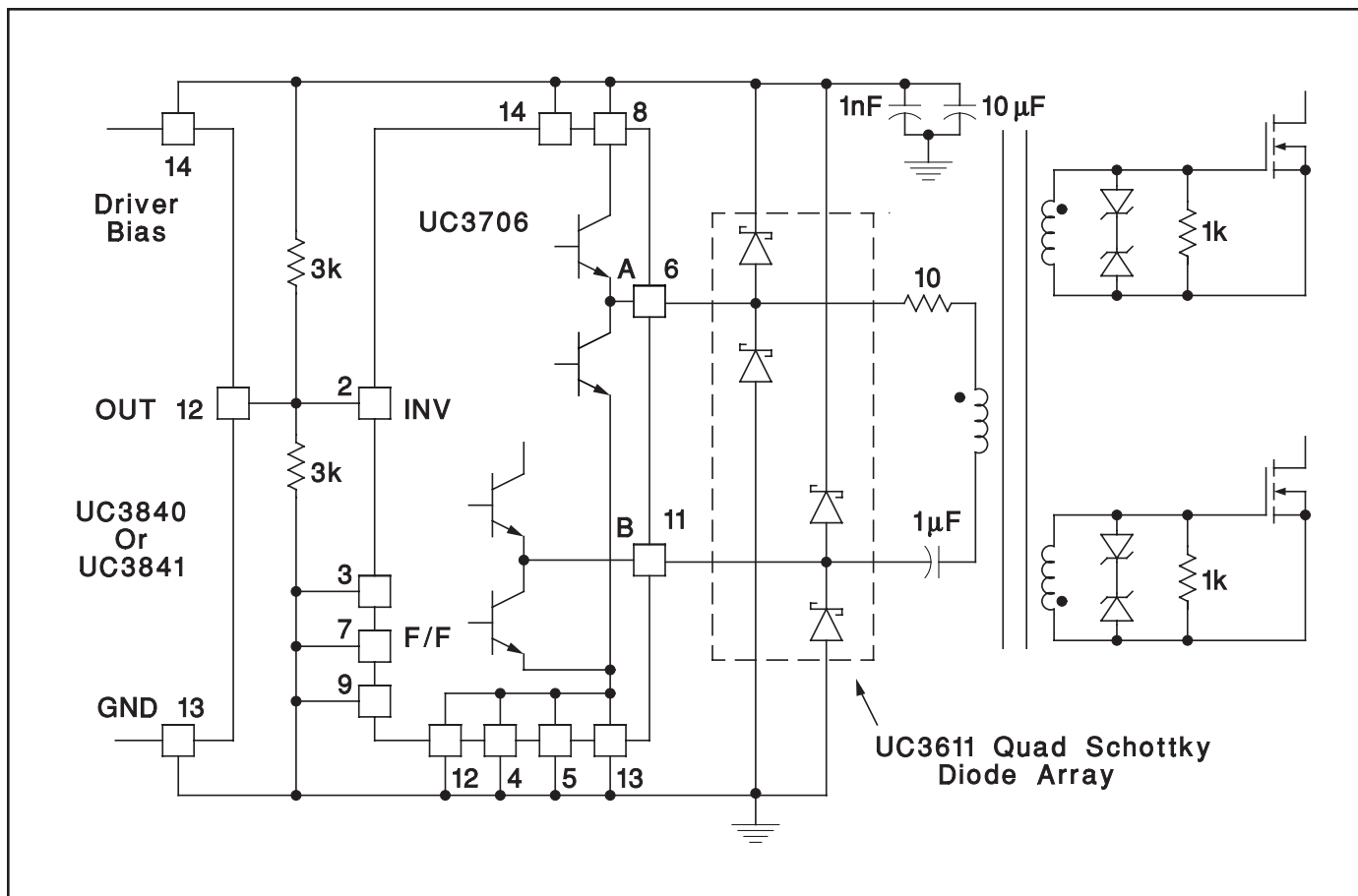

UC3706 Converts Single Output PWMs to High Current Push-Pull Configuration

PACKAGING INFORMATION

| Orderable Device | Status (1) | Package Type | Package Drawing | Pins | Package Qty | Eco Plan (2) | Lead finish/ Ball material (6) | MSL Peak Temp (3) | Op Temp (°C) | Device Marking (4/5) | Samples |
|------------------|---------------|--------------|-----------------|------|-------------|------------------|--------------------------------------|----------------------|--------------|-------------------------|-------------------------|
| 5962-89611012A | ACTIVE | LCCC | FK | 20 | 55 | Non-RoHS & Green | SNPB | N / A for Pkg Type | -55 to 125 | 5962-89611012A | Samples |
| 5962-8961101EA | ACTIVE | CDIP | J | 16 | 25 | Non-RoHS & Green | SNPB | N / A for Pkg Type | -55 to 125 | 5962-8961101EA | Samples |
| UC1706J | ACTIVE | CDIP | J | 16 | 25 | Non-RoHS & Green | SNPB | N / A for Pkg Type | -55 to 125 | UC1706J | Samples |
| UC1706J883B | ACTIVE | CDIP | J | 16 | 25 | Non-RoHS & Green | SNPB | N / A for Pkg Type | -55 to 125 | UC1706J/883B | Samples |
| UC1706L | ACTIVE | LCCC | FK | 20 | 55 | Non-RoHS & Green | SNPB | N / A for Pkg Type | -55 to 125 | UC1706L | Samples |
| UC2706DW | ACTIVE | SOIC | DW | 16 | 40 | RoHS & Green | NIPDAU | Level-2-260C-1 YEAR | -40 to 85 | UC2706DW | Samples |
| UC2706J | ACTIVE | CDIP | J | 16 | 25 | Non-RoHS & Green | SNPB | N / A for Pkg Type | -40 to 85 | UC2706J | Samples |
| UC2706N | ACTIVE | PDIP | N | 16 | 25 | RoHS & Green | NIPDAU | N / A for Pkg Type | -40 to 85 | UC2706N | Samples |
| UC3706DW | ACTIVE | SOIC | DW | 16 | 40 | RoHS & Green | NIPDAU | Level-2-260C-1 YEAR | 0 to 70 | UC3706DW | Samples |
| UC3706DWTR | ACTIVE | SOIC | DW | 16 | 2000 | RoHS & Green | NIPDAU | Level-2-260C-1 YEAR | 0 to 70 | UC3706DW | Samples |
| UC3706N | ACTIVE | PDIP | N | 16 | 25 | RoHS & Green | NIPDAU | N / A for Pkg Type | 0 to 70 | UC3706N | Samples |
| UC3706NG4 | ACTIVE | PDIP | N | 16 | 25 | RoHS & Green | NIPDAU | N / A for Pkg Type | 0 to 70 | UC3706N | Samples |

(1) The marketing status values are defined as follows:

ACTIVE: Product device recommended for new designs.

LIFEBUY: TI has announced that the device will be discontinued, and a lifetime-buy period is in effect.

NRND: Not recommended for new designs. Device is in production to support existing customers, but TI does not recommend using this part in a new design.

PREVIEW: Device has been announced but is not in production. Samples may or may not be available.

OBSOLETE: TI has discontinued the production of the device.

(2) **RoHS:** TI defines "RoHS" to mean semiconductor products that are compliant with the current EU RoHS requirements for all 10 RoHS substances, including the requirement that RoHS substance do not exceed 0.1% by weight in homogeneous materials. Where designed to be soldered at high temperatures, "RoHS" products are suitable for use in specified lead-free processes. TI may reference these types of products as "Pb-Free".

RoHS Exempt: TI defines "RoHS Exempt" to mean products that contain lead but are compliant with EU RoHS pursuant to a specific EU RoHS exemption.

Green: TI defines "Green" to mean the content of Chlorine (Cl) and Bromine (Br) based flame retardants meet JS709B low halogen requirements of ≤ 1000 ppm threshold. Antimony trioxide based flame retardants must also meet the ≤ 1000 ppm threshold requirement.

- (3) MSL, Peak Temp. - The Moisture Sensitivity Level rating according to the JEDEC industry standard classifications, and peak solder temperature.
- (4) There may be additional marking, which relates to the logo, the lot trace code information, or the environmental category on the device.
- (5) Multiple Device Markings will be inside parentheses. Only one Device Marking contained in parentheses and separated by a "~" will appear on a device. If a line is indented then it is a continuation of the previous line and the two combined represent the entire Device Marking for that device.
- (6) Lead finish/Ball material - Orderable Devices may have multiple material finish options. Finish options are separated by a vertical ruled line. Lead finish/Ball material values may wrap to two lines if the finish value exceeds the maximum column width.

Important Information and Disclaimer: The information provided on this page represents TI's knowledge and belief as of the date that it is provided. TI bases its knowledge and belief on information provided by third parties, and makes no representation or warranty as to the accuracy of such information. Efforts are underway to better integrate information from third parties. TI has taken and continues to take reasonable steps to provide representative and accurate information but may not have conducted destructive testing or chemical analysis on incoming materials and chemicals. TI and TI suppliers consider certain information to be proprietary, and thus CAS numbers and other limited information may not be available for release.

In no event shall TI's liability arising out of such information exceed the total purchase price of the TI part(s) at issue in this document sold by TI to Customer on an annual basis.

OTHER QUALIFIED VERSIONS OF UC1706, UC2706, UC2706M, UC3706 :

- Catalog : [UC3706](#), [UC2706](#)
- Military : [UC2706M](#), [UC1706](#)

NOTE: Qualified Version Definitions:

- Catalog - TI's standard catalog product
- Military - QML certified for Military and Defense Applications

TAPE AND REEL INFORMATION

QUADRANT ASSIGNMENTS FOR PIN 1 ORIENTATION IN TAPE

*All dimensions are nominal

| Device | Package Type | Package Drawing | Pins | SPQ | Reel Diameter (mm) | Reel Width W1 (mm) | A0 (mm) | B0 (mm) | K0 (mm) | P1 (mm) | W (mm) | Pin1 Quadrant |
|------------|--------------|-----------------|------|------|--------------------|--------------------|---------|---------|---------|---------|--------|---------------|
| UC3706DWTR | SOIC | DW | 16 | 2000 | 330.0 | 16.4 | 10.75 | 10.7 | 2.7 | 12.0 | 16.0 | Q1 |

TAPE AND REEL BOX DIMENSIONS

*All dimensions are nominal

| Device | Package Type | Package Drawing | Pins | SPQ | Length (mm) | Width (mm) | Height (mm) |
|------------|--------------|-----------------|------|------|-------------|------------|-------------|
| UC3706DWTR | SOIC | DW | 16 | 2000 | 356.0 | 356.0 | 35.0 |

TUBE

*All dimensions are nominal

| Device | Package Name | Package Type | Pins | SPQ | L (mm) | W (mm) | T (μm) | B (mm) |
|----------------|--------------|--------------|------|-----|--------|--------|--------|--------|
| 5962-89611012A | FK | LCCC | 20 | 55 | 506.98 | 12.06 | 2030 | NA |
| UC1706L | FK | LCCC | 20 | 55 | 506.98 | 12.06 | 2030 | NA |
| UC2706DW | DW | SOIC | 16 | 40 | 507 | 12.83 | 5080 | 6.6 |
| UC2706N | N | PDIP | 16 | 25 | 506 | 13.97 | 11230 | 4.32 |
| UC3706DW | DW | SOIC | 16 | 40 | 507 | 12.83 | 5080 | 6.6 |
| UC3706N | N | PDIP | 16 | 25 | 506 | 13.97 | 11230 | 4.32 |
| UC3706NG4 | N | PDIP | 16 | 25 | 506 | 13.97 | 11230 | 4.32 |

IMPORTANT NOTICE AND DISCLAIMER

TI PROVIDES TECHNICAL AND RELIABILITY DATA (INCLUDING DATA SHEETS), DESIGN RESOURCES (INCLUDING REFERENCE DESIGNS), APPLICATION OR OTHER DESIGN ADVICE, WEB TOOLS, SAFETY INFORMATION, AND OTHER RESOURCES "AS IS" AND WITH ALL FAULTS, AND DISCLAIMS ALL WARRANTIES, EXPRESS AND IMPLIED, INCLUDING WITHOUT LIMITATION ANY IMPLIED WARRANTIES OF MERCHANTABILITY, FITNESS FOR A PARTICULAR PURPOSE OR NON-INFRINGEMENT OF THIRD PARTY INTELLECTUAL PROPERTY RIGHTS.

These resources are intended for skilled developers designing with TI products. You are solely responsible for (1) selecting the appropriate TI products for your application, (2) designing, validating and testing your application, and (3) ensuring your application meets applicable standards, and any other safety, security, regulatory or other requirements.

These resources are subject to change without notice. TI grants you permission to use these resources only for development of an application that uses the TI products described in the resource. Other reproduction and display of these resources is prohibited. No license is granted to any other TI intellectual property right or to any third party intellectual property right. TI disclaims responsibility for, and you will fully indemnify TI and its representatives against, any claims, damages, costs, losses, and liabilities arising out of your use of these resources.

TI's products are provided subject to [TI's Terms of Sale](#) or other applicable terms available either on [ti.com](https://www.ti.com) or provided in conjunction with such TI products. TI's provision of these resources does not expand or otherwise alter TI's applicable warranties or warranty disclaimers for TI products.

TI objects to and rejects any additional or different terms you may have proposed.

Mailing Address: Texas Instruments, Post Office Box 655303, Dallas, Texas 75265
Copyright © 2024, Texas Instruments Incorporated

Looking for pricing, stock, or lifecycle information?

Click below to explore more details on WIN SOURCE:

 [View UC3706DWTRG4](#) on WIN SOURCE

 [Texas Instruments](#) Information

Optimize Your Supply Chain with WIN SOURCE Solutions

-  Global Sourcing Solution
-  Obsolete Management
-  Cost Control Management
-  Shortage Management
-  Alternative Solution
-  Excess Inventory Management