



**THE DATASHEET OF
TXBN0304RUTR**



TXB0304 4-Bit Bidirectional Level-Shifter/Voltage Translator with Automatic Direction Sensing

1 Features

- Fully Symmetric Supply Voltages, 0.9 V to 3.6 V on A Port and 0.9 V to 3.6 V
- V_{CC} Isolation Feature – If Either V_{CC} Input is at GND, all Outputs are in High-Impedance State
- OE Input Circuit Referenced to V_{CCA}
- Low Power Consumption, 5 μ A Max (I_{CCA} or I_{CCB})
- I_{off} Supports Partial-Power-Down Mode Operation
- Latch-Up Performance Exceeds 100 mA Per JESD 78, Class II
- ESD Protection Exceeds JESD 22
 - 8000-V Human-Body Model (A114-B)
 - 1000-V Charged-Device Model (C101)

2 Applications

- Personal Electronics
- Industrial
- Enterprise
- Telecom

3 Description

This 4-bit non-inverting translator uses two separate configurable power-supply rails. The A port is designed to track V_{CCA} . V_{CCA} accepts any supply voltage from 0.9 V to 3.6 V. The B port is designed to track V_{CCB} . V_{CCB} accepts any supply voltage from 0.9 V to 3.6 V. This allows for low Voltage bidirectional translation between 1 V, 1.2 V, 1.5 V, 1.8 V, 2.5 V and 3.3 V voltage nodes. For the TXB0304, when the output-enable (OE) input is low, all outputs are placed in the high-impedance state. To ensure the high-impedance state during power up or power down, OE should be tied to GND through a pull-down resistor; the minimum value of the resistor is determined by the current-sourcing capability of the driver. The OE device control pin input circuit is supplied by V_{CCA} . This device is fully specified for partial-power-down applications using I_{off} . The I_{off} circuitry disables the outputs, preventing damaging current backflow through the device when it is powered down. The only difference between TXB0304 and TXBN0304 is the OE signal being active high and active low respectively.

Device Information⁽¹⁾

PART NUMBER	PACKAGE	BODY SIZE (NOM)
TXB0304	RUT UQFN (12)	2.00 mm x 1.70 mm
	RSV UQFN (16)	2.60 mm x 1.80 mm

(1) For all available packages, see the orderable addendum at the end of the datasheet.

Typical Application Block Diagram for TXB0304

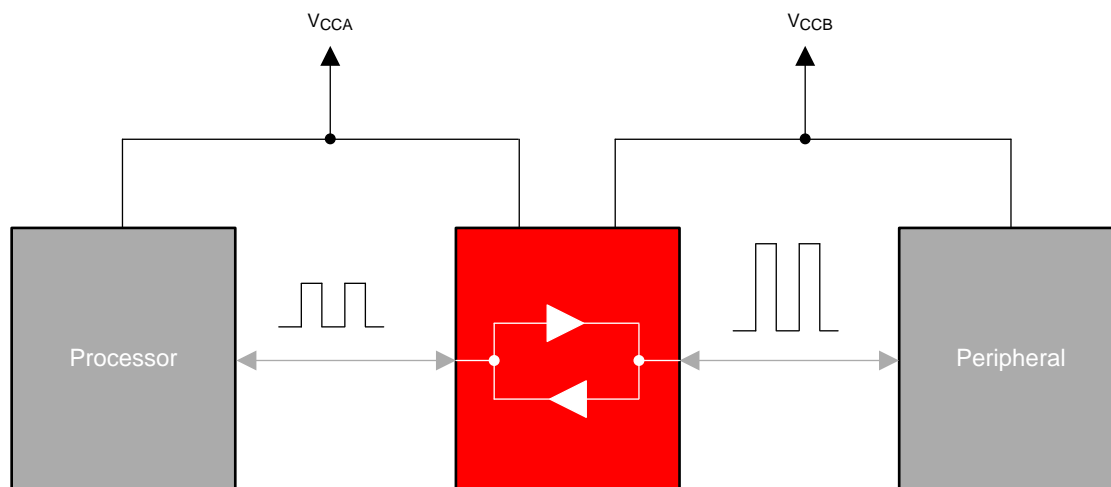

Copyright © 2016, Texas Instruments Incorporated



Table of Contents

1 Features	1	8.2 Functional Block Diagram	10
2 Applications	1	8.3 Feature Description	11
3 Description	1	8.4 Device Functional Modes	11
4 Revision History	2	9 Application and Implementation	12
5 Pin Configuration and Functions	3	9.1 Application Information	12
6 Specifications	4	9.2 Typical Application	12
6.1 Absolute Maximum Ratings	4	10 Power Supply Recommendations	13
6.2 ESD Ratings	4	11 Layout	13
6.3 Recommended Operating Conditions	4	11.1 Layout Guidelines	13
6.4 Thermal Information	5	11.2 Layout Example	14
6.5 Electrical Characteristics	5	12 Device and Documentation Support	15
6.6 Timing Requirements	6	12.1 Device Support	15
6.7 Switching Characteristics	6	12.2 Documentation Support	15
6.8 Operating Characteristics	7	12.3 Community Resources	15
6.9 Typical Characteristics	7	12.4 Trademarks	15
7 Parameter Measurement Information	8	12.5 Electrostatic Discharge Caution	15
8 Detailed Description	10	12.6 Glossary	15
8.1 Overview	10	13 Mechanical, Packaging, and Orderable Information	15

4 Revision History

NOTE: Page numbers for previous revisions may differ from page numbers in the current version.

Changes from Revision F (May 2016) to Revision G	Page
• Changed text in <i>Power Supply Recommendations</i> section.	13
Changes from Revision E (August 2014) to Revision F	Page
• Made changes to <i>Description</i> section	1
• Made changes to <i>Absolute Maximum Ratings</i> , <i>Recommended Operating Conditions</i> ⁽¹⁾⁽²⁾ , <i>Switching Characteristics</i> and <i>Electrical Characteristics</i> tables	1
Changes from Revision D (October 2012) to Revision E	Page
• Added <i>ESD Ratings</i> table, <i>Feature Description</i> section, <i>Device Functional Modes</i> , <i>Application and Implementation</i> section, <i>Power Supply Recommendations</i> section, <i>Layout</i> section, <i>Device and Documentation Support</i> section, and <i>Mechanical, Packaging, and Orderable Information</i> section.	1
• Changed VCCA and VCCB in the ABS MAX table to V _{CCA} and V _{CCB} in 3 places	4
• Changed in ELEC CHARAC table the 0.9 x V _{CCA} and 0.9 x V _{CCB} from MAX column into the MIN column	5
• Changed in ELEC CHARAC table 0.2 (2 places) in the MIN column to the MAX	5
Changes from Revision C (May 2012) to Revision D	Page
• Added <i>Application Information</i> section	12
Changes from Revision B (September 2011) to Revision C	Page
• Added package pin out diagram notes	3

5 Pin Configuration and Functions

**RSV Package
16-Pin UQFN
TXB0304 Top View**

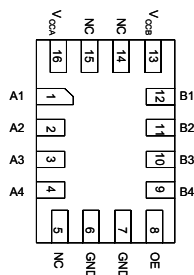

**RUT Package
12-Pin UQFN
TXB0304 Top View**

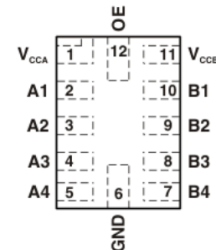

**RSV Package
16-Pin UQFN
TXBN0304 Top View**

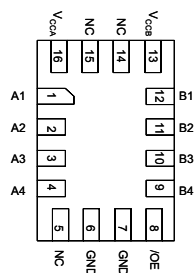

**RUT Package
12-Pin UQFN
TXBN0304 Top View**

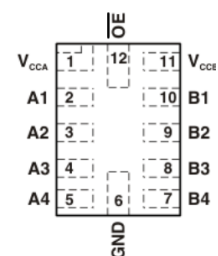

A. See [Layout Guidelines](#) for notes about package pin out diagrams.

Pin Functions

NAME	PIN		TYPE	DESCRIPTION			
	TXB0304	TXBN0304					
	RSV	RUT	RSV	RUT			
A1	1	2	1	2	I/O	Input/output 1	Referenced to V_{CCA}
A2	2	3	2	3	I/O	Input/output 2	
A3	3	4	3	4	I/O	Input/output 3	
A4	4	5	4	5	I/O	Input/output 4	
B1	12	10	12	10	I/O	Input/output 4	Referenced to V_{CCB}
B2	11	9	11	9	I/O	Input/output 3	
B3	10	8	10	8	I/O	Input/output 2	
B4	9	7	9	7	I/O	Input/output 1	
GND	6, 7	6	6, 7	6	GND	Ground	
NC	5, 14, 15	—	5, 14, 15	—	—	No connection; not internally connected	
OE	8	12	—	—	I	3-state output-mode enable. Pull OE (TXB0304) low to place all outputs in 3-state mode. Referenced to V_{CCA} .	
\overline{OE}	—	—	8	12	I	3-state output-mode enable. Pull \overline{OE} (TXBN0304) high to place all outputs in 3-state mode. Referenced to V_{CCA} .	
V_{CCA}	16	1	16	1	—	A-port supply voltage $0.9\text{ V} \leq V_{CCA} \leq 3.6\text{ V}$	
V_{CCB}	13	11	13	11	—	B-port supply voltage $0.9\text{ V} \leq V_{CCB} \leq 3.6\text{ V}$	

6 Specifications

6.1 Absolute Maximum Ratings

 over operating free-air temperature range (unless otherwise noted) ⁽¹⁾

			MIN	MAX	UNIT
V_{CCA}	Supply voltage		-0.5	4.6	V
V_{CCB}			-0.5	4.6	
V_I	Input voltage	A port	-0.5	4.6	V
		B port	-0.5	4.6	
V_O	Voltage applied to any output in the high-impedance or power-off state	A port	-0.5	4.6	V
		B port	-0.5	4.6	
V_O	Voltage applied to any output in the high or low state ⁽²⁾	A port	-0.5	$V_{CCA} + 0.5$	V
		B port	-0.5	$V_{CCB} + 0.5$	
I_{IK}	Input clamp current	$V_I < 0$		-50	mA
I_{OK}	Output clamp current	$V_O < 0$		-50	mA
I_O	Continuous output current			±50	mA
	Continuous current through V_{CCA} , V_{CCB} , or GND			±100	mA
T_{stg}	Storage temperature		-65	150	°C
T_J	Junction temperature		-40	125	°C

- (1) Stresses beyond those listed under *Absolute Maximum Ratings* may cause permanent damage to the device. These are stress ratings only, which do not imply functional operation of the device at these or any other conditions beyond those indicated under *Recommended Operating Conditions*. Exposure to absolute-maximum-rated conditions for extended periods may affect device reliability.
- (2) The value of V_{CCA} and V_{CCB} are provided in the recommended operating conditions table.

6.2 ESD Ratings

			VALUE	UNIT
$V_{(ESD)}$	Electrostatic discharge	Human body model (HBM), per ANSI/ESDA/JEDEC JS-001, all pins ⁽¹⁾	±8000	V
		Charged device model (CDM), per JEDEC specification JESD22-C101, all pins ⁽²⁾	±1000	

- (1) JEDEC document JEP155 states that 500-V HBM allows safe manufacturing with a standard ESD control process.
- (2) JEDEC document JEP157 states that 250-V CDM allows safe manufacturing with a standard ESD control process.

6.3 Recommended Operating Conditions ⁽¹⁾⁽²⁾

			V_{CCA}	V_{CCB}	MIN	MAX	UNIT
V_{CCA}	Supply voltage				0.9	3.6	V
V_{CCB}							
V_{IH}	High-level input voltage	Data inputs	0.9 V to 3.6 V	0.9 V to 3.6 V	$V_{CCI} \times 0.65$	V_{CCI}	V
		OE/ \overline{OE}	0.9 V to 3.6 V	0.9 V to 3.6 V	$V_{CCA} \times 0.65$	3.6	
V_{IL}	Low-level input voltage	Data inputs	0.9 V to 3.6 V	0.9 V to 3.6 V	0	$V_{CCI} \times 0.35$	V
		OE/ \overline{OE}	0.9 V to 1.2 V	0.9 V to 3.6 V	0	$V_{CCA} \times 0.3$	
			1.2 V to 3.6 V	0.9 V to 3.6 V	0	$V_{CCA} \times 0.35$	
V_O	Voltage range applied to any output in the high-impedance or power-off state	A-port	0.9 V to 3.6 V	0.9 V to 3.6 V	0	3.6	V
		B-port	0.9 V to 3.6 V	0.9 V to 3.6 V	0	3.6	
$\Delta t/\Delta v$	Input transition rise or fall rate	A-port inputs	0.9 V to 3.6 V	0.9 V to 3.6 V		40	ns/V
		B-port inputs	0.9 V to 3.6 V	0.9 V to 3.6 V		40	
T_A	Operating free-air temperature				-40	85	°C

- (1) The A and B sides of an unused data I/O pair must be held in the same state, such as, both at V_{CCI} or both at GND.
- (2) V_{CCI} is the supply voltage associated with the input port.

6.4 Thermal Information

THERMAL METRIC ⁽¹⁾		TXB0304		UNIT
		RUT (UQFN)	RSV (UQFN)	
		12 PINS	16 PINS	
$R_{\theta JA}$	Junction-to-ambient thermal resistance	116.4	131.7	°C/W
$R_{\theta JC(top)}$	Junction-to-case (top) thermal resistance	45.7	55.8	°C/W
$R_{\theta JB}$	Junction-to-board thermal resistance	46.9	55.3	°C/W
Ψ_{JT}	Junction-to-top characterization parameter	0.6	1.4	°C/W
Ψ_{JB}	Junction-to-board characterization parameter	46.9	55.3	°C/W

(1) For more information about traditional and new thermal metrics, see the *Semiconductor and IC Package Thermal Metrics* application report, [SPRA953](#).

6.5 Electrical Characteristics

over operating free-air temperature range (unless otherwise noted)

PARAMETER		TEST CONDITIONS		V_{CCA}	V_{CCB}	MIN	TYP	MAX	UNIT
V_{OHA}	High-level output voltage	$I_{OH} = -20 \mu A$	$T_A = 25^\circ C$	0.9 V to 3.6 V		$0.9 \times V_{CCA}$			V
V_{OLA}	Low-level output voltage	$I_{OL} = 20 \mu A$	$-40^\circ C$ to $85^\circ C$	0.9 V to 3.6 V				0.2	V
V_{OHB}	High-level output voltage	$I_{OH} = -20 \mu A$	$T_A = 25^\circ C$		0.9 V to 3.6 V	$0.9 \times V_{CCB}$			V
V_{OLB}	Low-level output voltage	$I_{OL} = 20 \mu A$	$-40^\circ C$ to $85^\circ C$		0.9 V to 3.6 V			0.2	V
I_I	OE	$V_I = V_{CCI}$ or GND	$T_A = 25^\circ C$	0.9 V to 3.6 V	0.9 V to 3.6 V			± 1	μA
			$-40^\circ C$ to $85^\circ C$					± 2	
I_{off}	A port	V_I or $V_O = 0$ to 3.6 V	$T_A = 25^\circ C$	0 V	0 V to 3.6 V			± 1	μA
	B port		$-40^\circ C$ to $85^\circ C$					± 2	
I_{OZ}		A or B port	OE = GND	$T_A = 25^\circ C$	0.9 V to 3.6 V	0.9 V to 3.6 V			
	$-40^\circ C$ to $85^\circ C$			± 2					
I_{CCA}		$V_I = V_{CCI}$ or GND, $I_O = 0$	$-40^\circ C$ to $85^\circ C$	0.9 V to 3.6 V	0.9 V to 3.6 V			5	μA
I_{CCB}		$V_I = V_{CCB}$ or GND, $I_O = 0$	$-40^\circ C$ to $85^\circ C$	0.9 V to 3.6 V	0.9 V to 3.6 V			5	μA
$I_{CCA} + I_{CCB}$		$V_I = V_{CCI}$ or GND, $I_O = 0$	$-40^\circ C$ to $85^\circ C$	0.9 V to 3.6 V	0.9 V to 3.6 V			10	μA
I_{CCZA}	High-Z state supply current	$V_I = V_{CCI}$ or GND, $I_O = 0$, OE = GND	$-40^\circ C$ to $85^\circ C$	0.9 V to 3.6 V	0.9 V to 3.6 V			5	μA
I_{CCZB}	High-Z state supply current	$V_I = V_{CCB}$ or GND, $I_O = 0$, OE = GND	$-40^\circ C$ to $85^\circ C$	0.9 V to 3.6 V	0.9 V to 3.6 V			5	μA
C_i	OE	$T_A = 25^\circ C$		0.9 V to 3.6 V	0.9 V to 3.6 V			3	pF
C_{io}	A port	$T_A = 25^\circ C$, OE = GND		0.9 V to 3.6 V	0.9 V to 3.6 V			6.7	pF
	B port					6.7			

6.6 Timing Requirements

over recommended operating free-air temperature range (unless otherwise noted)

PARAMETER	LOAD	V _{CCA}	V _{CCB}	MIN	MAX	UNIT
Data rate	C _L = 15 pF	0.9 to 3.6 V	0.9 to 3.6 V		50	Mbps
	C _L = 15 pF	1.2 to 3.6 V	1.2 to 3.6 V		100	Mbps
	C _L = 15 pF	1.8 to 3.6 V	1.8 to 3.6 V		140	Mbps
	C _L = 30 pF	0.9 to 3.6 V	0.9 to 3.6 V		40	Mbps
	C _L = 30 pF	1.2 to 3.6 V	1.2 to 3.6 V		90	Mbps
	C _L = 30 pF	1.8 to 3.6 V	1.8 to 3.6 V		130	Mbps
	C _L = 50 pF	1.2 to 3.6 V	1.2 to 3.6 V		80	Mbps
	C _L = 50 pF	1.8 to 3.6 V	1.8 to 3.6 V		120	Mbps
	C _L = 100 pF	1.2 to 3.6 V	1.2 to 3.6 V		70	Mbps
C _L = 100 pF	1.8 to 3.6 V	1.8 to 3.6 V		100	Mbps	

6.7 Switching Characteristics

 over operating free-air temperature range (unless otherwise noted). (For parameter descriptions, see [Figure 2](#) and [Figure 3](#).)

PARAMETER	FROM (INPUT)	TO (OUTPUT)	LOAD	V _{CCA}	V _{CCB}	MIN	TYP ⁽¹⁾	MAX	UNIT
t _{pd}	A	B	C _L = 15	0.9-3.6	0.9-3.6		18.9	30	ns
	A	B	C _L = 15	1.2-3.6	1.2-3.6		7.5	11.5	
	A	B	C _L = 15	1.8-3.6	1.8-3.6		3.7	4.8	
	A	B	C _L = 30	0.9-3.6	0.9-3.6		19.5	34	
	A	B	C _L = 30	1.2-3.6	1.2-3.6		7.8	11.9	
	A	B	C _L = 30	1.8-3.6	1.8-3.6		3.8	5.2	
	A	B	C _L = 50	1.2-3.6	1.2-3.6		8	12.3	
	A	B	C _L = 50	1.8-3.6	1.8-3.6		4	5.4	
	A	B	C _L = 100	1.2-3.6	1.2-3.6		8.6	13.5	
	B	A	C _L = 15	0.9-3.6	0.9-3.6		18.9	30	ns
	B	A	C _L = 15	1.2-3.6	1.2-3.6		7.5	11.5	
	B	A	C _L = 15	1.8-3.6	1.8-3.6		3.7	5	
	B	A	C _L = 30	0.9-3.6	0.9-3.6		19.5	34	
	B	A	C _L = 30	1.2-3.6	1.2-3.6		7.8	11.9	
	B	A	C _L = 30	1.8-3.6	1.8-3.6		3.8	5.2	
	B	A	C _L = 50	1.2-3.6	1.2-3.6		8	12.3	
	B	A	C _L = 50	1.8-3.6	1.8-3.6		4	5.4	
	B	A	C _L = 100	1.2-3.6	1.2-3.6		8.6	13.5	
t _{en}	OE	A	C _L = 15	0.9-3.6	0.9-3.6			262	ns
				1.2-3.6	1.2-3.6			64	
				1.8-3.6	1.8-3.6			37	
		B	C _L = 15	0.9-3.6	0.9-3.6			332	
				1.2-3.6	1.2-3.6			76	
				1.8-3.6	1.8-3.6			41	
t _{dis}	OE	A	C _L = 15	0.9-3.6	0.9-3.6			172	ns
		B	C _L = 15	0.9-3.6	0.9-3.6			169	ns
t _{FB} , t _{FB}	B-port rise and fall times		C _L = 15	0.9-3.6	0.9-3.6		2.95		ns
t _{SA} , t _{SA}	A-port rise and fall times		C _L = 15	0.9-3.6	0.9-3.6		3.1		ns
t _{SK(O)}	Channel-to-channel skew		C _L = 15	0.9-3.6	0.9-3.6			0.15	ns

 (1) T_A = 25°C

6.8 Operating Characteristics

C_{pd} - power dissipation capacitance measured at $T_A = 25^\circ\text{C}$.

PARAMETER		TEST CONDITIONS	TYP ⁽¹⁾	UNIT	
C_{pdA}	A-port input, B-port output	$C_L = 0, f = 10 \text{ MHz}, t_r = t_f = 1 \text{ ns}, OE = V_{CCA}$ (outputs enabled)	34	pF	
	B-port input, A-port output		34		
C_{pdB}	A-port input, B-port output		34	pF	
	B-port input, A-port output		34		
C_{pdA}	A-port input, B-port output		$C_L = 0, f = 10 \text{ MHz}, t_r = t_f = 1 \text{ ns}, OE = \text{GND}$ (outputs disabled)	0.01	pF
	B-port input, A-port output			0.01	
C_{pdB}	A-port input, B-port output	0.01		pF	
	B-port input, A-port output	0.01			

(1) V_{CCA}, V_{CCB} 0.9 V to 3.6 V

6.9 Typical Characteristics

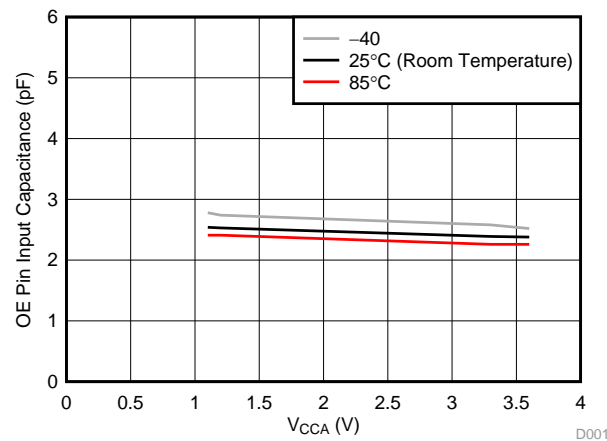
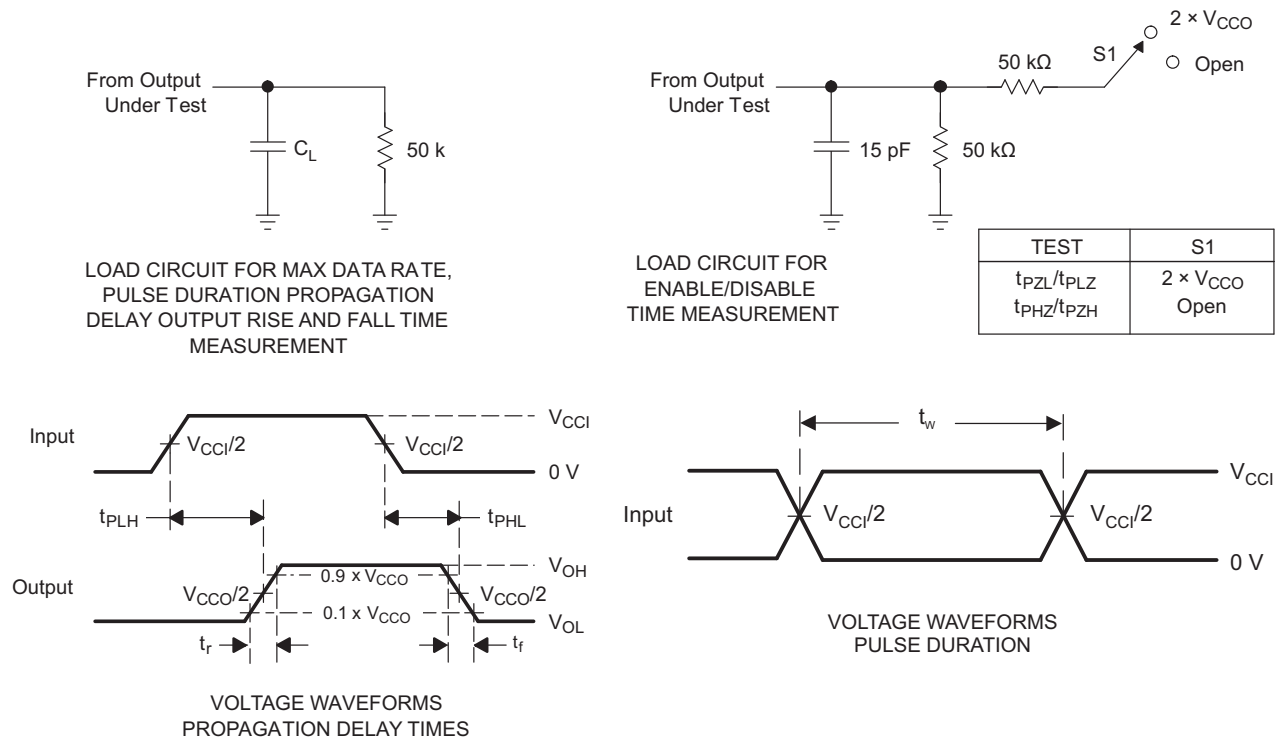

Figure 1. Input Capacitors for OE Pin (C_i) vs Power Supply (V_{CCA})

7 Parameter Measurement Information



- A. C_L includes probe and jig capacitance.
- B. All input pulses are supplied by generators having the following characteristics: PRR 10 MHz, $Z_0 = 50 \Omega$, $dv/dt \geq 1$ V/ns.
- C. The outputs are measured one at a time, with one transition per measurement.
- D. t_{PLH} and t_{PHL} are the same as t_{pd} .
- E. V_{CCI} is the V_{CC} associated with the input port.
- F. V_{CCO} is the V_{CC} associated with output port.
- G. All parameters and waveforms are not applicable to all devices.

Figure 2. Load Circuits and Voltage Waveforms

Parameter Measurement Information (continued)

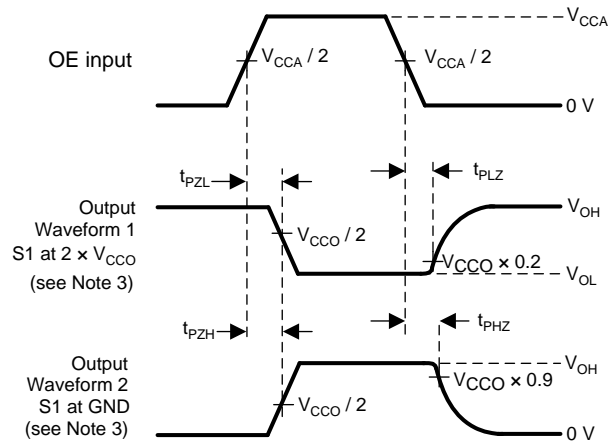

- (1) t_{PLZ} and t_{PHZ} are the same as t_{dis} .
- (2) t_{PZL} and t_{PZH} are the same as t_{en} .
- (3) Waveform 1 is for an output with internal such that the output is high, except when OE is high. Waveform 2 is for an output with conditions such that the output is low, except when OE is high.

Figure 3. Enable and Disable Times

8 Detailed Description

8.1 Overview

The TXB0304 and TXBN0304 can be used in level-translation applications for interfacing devices or systems operating at different interface voltages with one another.

8.1.1 Architecture

The TXB0304 and TXBN0304 architecture (see [Figure 4](#)) does not require a direction-control signal to control the direction of data flow from A to B or from B to A. In a dc state, the output drivers of the TXB0304 can maintain a high or low, but are designed to be weak, so that they can be overdriven by an external driver when data on the bus starts flowing the opposite direction. The output one shots detect rising or falling edges on the A or B ports. During a rising edge, the one shot turns on the PMOS transistors (T1, T3) for a short duration, which speeds up the low-to-high transition. Similarly, during a falling edge, the one shot turns on the NMOS transistors (T2, T4) for a short duration, which speeds up the high-to-low transition. The typical output impedance during output transition is 30 Ω at $V_{CCO} = 0.9\text{ V to }1\text{ V}$, 10 Ω at $V_{CCO} = 1.1\text{ V to }1.7\text{ V}$, and 5 Ω at $V_{CCO} = 1.8\text{ V to }3.3\text{ V}$.

8.2 Functional Block Diagram

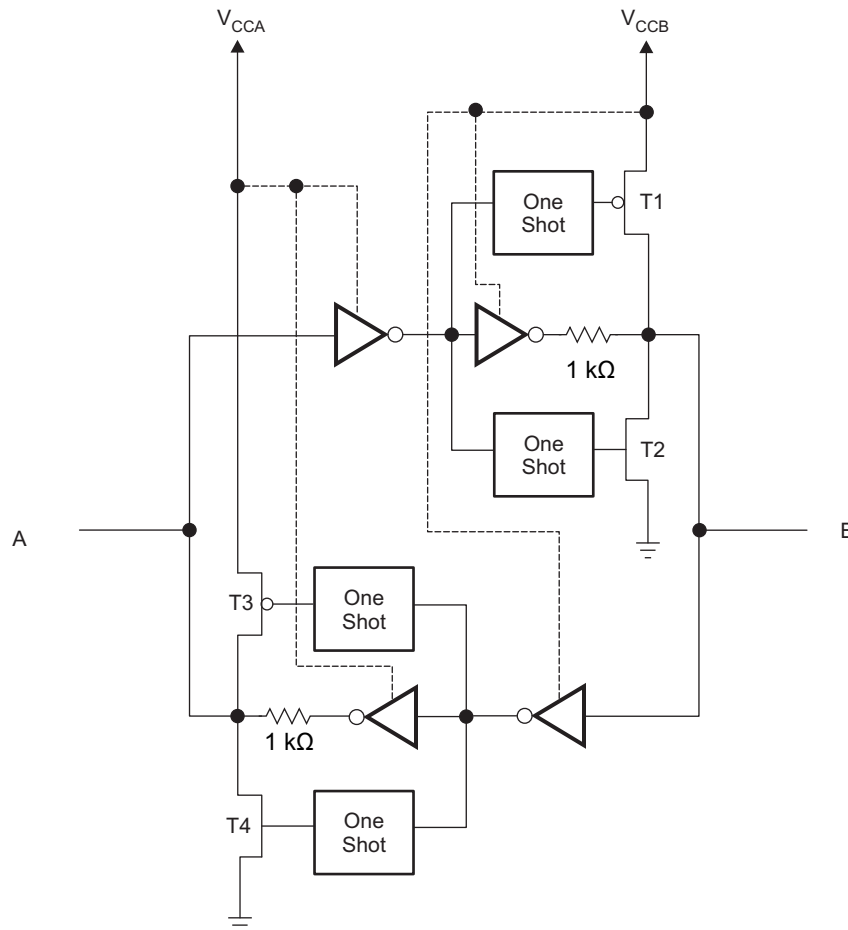

Copyright © 2016, Texas Instruments Incorporated

Figure 4. Architecture of TXB0304 I/O Cell

8.3 Feature Description

8.3.1 Input Driver Requirements

Typical I_{IN} vs V_{IN} characteristics of the TXB0304/TXBN0304 are shown in Figure 5. For proper operation, the device driving the data I/Os of the TXB0304 must have drive strength of at least ± 3 mA.

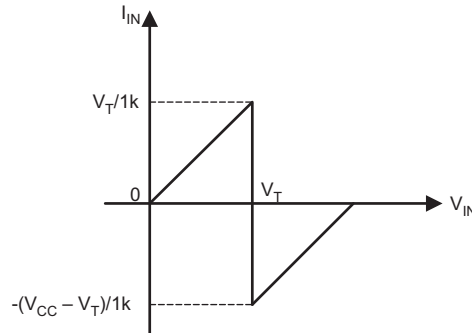

- (1) V_{CC} is power supply of TXB0304.
- (2) V_T is the input threshold voltage of TXB0304 (typically it is $V_{CC}/2$).

Figure 5. Typical I_{IN} vs V_{IN} Curve

8.4 Device Functional Modes

8.4.1 Enable and Disable

The TXB0304 has an OE input that is used to disable the device by setting OE = low (\overline{OE} = high for TXBN0304), which places all I/Os in the high-impedance (Hi-Z) state. The disable time (t_{dis}) indicates the delay between when OE goes low and when the outputs actually get disabled (Hi-Z). The enable time (t_{en}) indicates the amount of time the user must allow for the one-shot circuitry to become operational after OE is high.

8.4.2 Pullup or Pulldown Resistor on I/O Lines

The TXB0304/TXBN0304 is designed to drive capacitive loads of up to 100 pF. The output drivers of the TXB0304 have low dc drive strength. If pull-up or pull-down resistors are connected externally to the data I/Os, their values must be kept higher than 20 k Ω to ensure that they do not contend with the output drivers of the TXB0304. but if the receiver is integrated with the smaller pull down or pull up resistor, below formula can be used for estimation to evaluate the V_{OH} and V_{OL} .

$$V_{ol} = V_{CCout} \times \frac{1.5k\Omega}{1.5k\Omega + R_{pu}} \quad (1)$$

$$V_{oh} = V_{CCout} \times \frac{R_{pd}}{1.5k\Omega + R_{pd}}$$

where

- V_{CCOUT} is the output port supply voltage on either V_{CCA} or V_{CCB}
- R_{PD} is the value of the external pull down resistor
- R_{PU} is the value of the external pull up resistor
- 1.5 k Ω is the counting the variation of the serial resistor 1k Ω in the I/O line. (2)

Because of this restriction on external resistors, the TXB0304 should not be used in applications such as I²C or 1-Wire where an open-drain driver is connected on the bidirectional data I/O. For these applications, use a device from the TI [TXS010X](#) series of level translators.

9 Application and Implementation

NOTE

Information in the following applications sections is not part of the TI component specification, and TI does not warrant its accuracy or completeness. TI's customers are responsible for determining suitability of components for their purposes. Customers should validate and test their design implementation to confirm system functionality.

9.1 Application Information

The TXB0304 can be used in level-translation applications for interfacing devices or systems operating at different interface voltages with one another. It can only translate push-pull CMOS logic outputs. If for open-drain signal translation, please refer to TI [TXS010X](#) products. Any external pull-down or pull-up resistors are recommended larger than 20 kΩ.

9.2 Typical Application

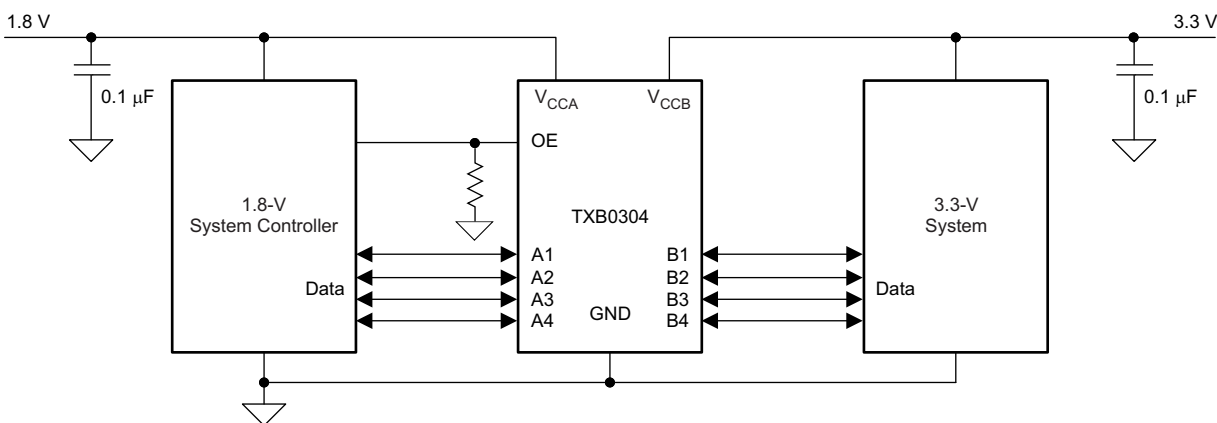

Copyright © 2016, Texas Instruments Incorporated

Figure 6. Typical Application Schematic

9.2.1 Design Requirements

For this design example, use the parameters listed in [Table 1](#).

Table 1. Design Parameters

DESIGN PARAMETERS	EXAMPLE VALUE
Input voltage range	0.9 V to 3.6 V
Output voltage range	0.9 V to 3.6 V

9.2.2 Detailed Design Procedure

To begin the design process, determine the following:

- Input voltage range
 - Use the supply voltage of the device that is driving the TXB0304 device to determine the input voltage range. For a valid logic high the value must exceed the V_{IH} of the input port. For a valid logic low the value must be less than the V_{IL} of the input port.
- Output voltage range
 - Use the supply voltage of the device that the TXB0304 device is driving to determine the output voltage range.
 - Don't recommend to have the external pull-up or pull-down resistors. If mandatory, it is recommended the value should be larger than 20 kΩ.

- An external pull-down or pull-up resistor decreases the output V_{OH} and V_{OL} . Use the below equations in section 8.5.2 to draft estimate the V_{OH} and V_{OL} as a result of an external pull-down and pull-up resistor.

9.2.3 Application Curve

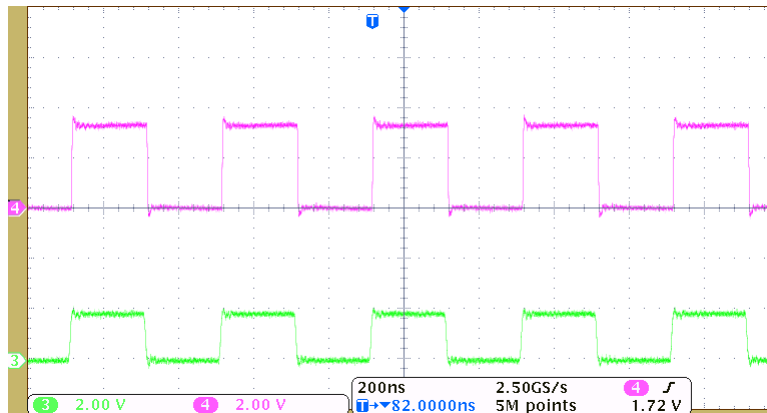

Figure 7. Level-Translation of a 2.5-MHz Signal

10 Power Supply Recommendations

During operation, TXB0304 can work at both $V_{CCA} \leq V_{CCB}$ and $V_{CCA} \geq V_{CCB}$. During power-up sequencing, any power supply can be ramped up first. Both the supplies are recommended to be powered down together. The TXB0304 has circuitry that disables all input/output ports when either VCC is switched off ($V_{CCA/B} = 0$ V).

11 Layout

11.1 Layout Guidelines

To ensure reliability of the device, following common printed-circuit board layout guidelines is recommended.

- Bypass capacitors should be used on power supplies. And should be placed as close as possible to the V_{CCA} , V_{CCB} pin and GND pin
- Short trace-lengths should be used to avoid excessive loading.
- For long transmission lines, place a series resistor equivalent to the impedance of the transmission lines to avoid signal integrity issues
- PCB signal trace-lengths must be kept short enough so that the round-trip delay of any reflection is less than the one-shot duration, approximately 10 ns, ensuring that any reflection encounters low impedance at the source driver.
- Pullup resistors are not required on both sides for Logic I/O.
- If pullup or pulldown resistors are needed, the resistor value must be over 20 k Ω .
- 20 k Ω is a safe recommended value, if the customer can accept higher V_{ol} or lower V_{oh} , smaller pull up or pull down resistor is allowed, the draft estimation is $V_{ol} = V_{ccout} \times 1.5k / (1.5k + R_{pu})$ and $V_{oh} = V_{ccout} \times R_{pd} / (1.5k + R_{pd})$.
- If pullup resistors are needed, please refer to the TXS0104 or contact TI.
- For detailed information, refer to application note [SCEA043](#).

11.2 Layout Example

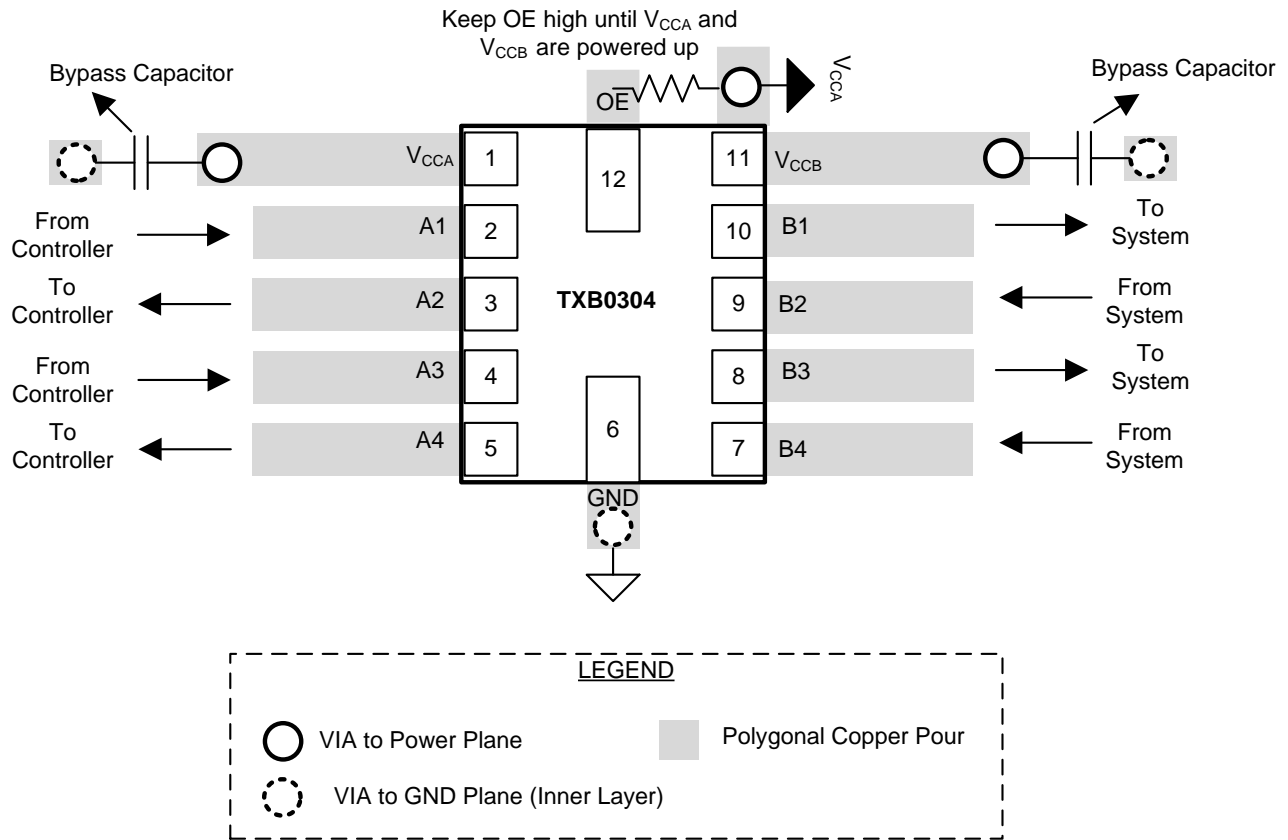

Figure 8. TXB0304 PCB Layout

12 Device and Documentation Support

12.1 Device Support

12.1.1 Development Support

For TI TXS010X products, go to www.ti.com/product/txs0101.

For the TXB0304 IBIS Model, see [SCEM544](#).

12.2 Documentation Support

12.2.1 Related Documentation

For related documentation see the following:

- Application Report, *A Guide to Voltage Translation With TXB-Type Translators*, [SCEA043](#)
- User's Guide, *TXB0304 Evaluation Module*, [SCEU003](#)

12.3 Community Resources

The following links connect to TI community resources. Linked contents are provided "AS IS" by the respective contributors. They do not constitute TI specifications and do not necessarily reflect TI's views; see TI's [Terms of Use](#).

TI E2E™ Online Community *TI's Engineer-to-Engineer (E2E) Community*. Created to foster collaboration among engineers. At e2e.ti.com, you can ask questions, share knowledge, explore ideas and help solve problems with fellow engineers.

Design Support *TI's Design Support* Quickly find helpful E2E forums along with design support tools and contact information for technical support.

12.4 Trademarks

E2E is a trademark of Texas Instruments.

All other trademarks are the property of their respective owners.

12.5 Electrostatic Discharge Caution



These devices have limited built-in ESD protection. The leads should be shorted together or the device placed in conductive foam during storage or handling to prevent electrostatic damage to the MOS gates.

12.6 Glossary

[SLYZ022](#) — *TI Glossary*.

This glossary lists and explains terms, acronyms, and definitions.

13 Mechanical, Packaging, and Orderable Information

The following pages include mechanical, packaging, and orderable information. This information is the most current data available for the designated devices. This data is subject to change without notice and revision of this document. For browser-based versions of this data sheet, refer to the left-hand navigation.

PACKAGING INFORMATION

Orderable Device	Status (1)	Package Type	Package Drawing	Pins	Package Qty	Eco Plan (2)	Lead finish/ Ball material (6)	MSL Peak Temp (3)	Op Temp (°C)	Device Marking (4/5)	Samples
TXB0304RSVR	ACTIVE	UQFN	RSV	16	3000	RoHS & Green	NIPDAUAG	Level-1-260C-UNLIM	-40 to 85	ZTJ	Samples
TXB0304RUTR	ACTIVE	UQFN	RUT	12	3000	RoHS & Green	NIPDAU NIPDAUAG	Level-1-260C-UNLIM	-40 to 85	(737, 73R, 73V)	Samples
TXBN0304RSVR	ACTIVE	UQFN	RSV	16	3000	RoHS & Green	NIPDAU NIPDAUAG	Level-1-260C-UNLIM	-40 to 85	ZTK	Samples
TXBN0304RUTR	ACTIVE	UQFN	RUT	12	3000	RoHS & Green	NIPDAUAG	Level-1-260C-UNLIM	-40 to 85	74R	Samples

(1) The marketing status values are defined as follows:

ACTIVE: Product device recommended for new designs.

LIFEBUY: TI has announced that the device will be discontinued, and a lifetime-buy period is in effect.

NRND: Not recommended for new designs. Device is in production to support existing customers, but TI does not recommend using this part in a new design.

PREVIEW: Device has been announced but is not in production. Samples may or may not be available.

OBSELETE: TI has discontinued the production of the device.

(2) **RoHS:** TI defines "RoHS" to mean semiconductor products that are compliant with the current EU RoHS requirements for all 10 RoHS substances, including the requirement that RoHS substance do not exceed 0.1% by weight in homogeneous materials. Where designed to be soldered at high temperatures, "RoHS" products are suitable for use in specified lead-free processes. TI may reference these types of products as "Pb-Free".

RoHS Exempt: TI defines "RoHS Exempt" to mean products that contain lead but are compliant with EU RoHS pursuant to a specific EU RoHS exemption.

Green: TI defines "Green" to mean the content of Chlorine (Cl) and Bromine (Br) based flame retardants meet JS709B low halogen requirements of <=1000ppm threshold. Antimony trioxide based flame retardants must also meet the <=1000ppm threshold requirement.

(3) MSL, Peak Temp. - The Moisture Sensitivity Level rating according to the JEDEC industry standard classifications, and peak solder temperature.

(4) There may be additional marking, which relates to the logo, the lot trace code information, or the environmental category on the device.

(5) Multiple Device Markings will be inside parentheses. Only one Device Marking contained in parentheses and separated by a "-" will appear on a device. If a line is indented then it is a continuation of the previous line and the two combined represent the entire Device Marking for that device.

(6) Lead finish/Ball material - Orderable Devices may have multiple material finish options. Finish options are separated by a vertical ruled line. Lead finish/Ball material values may wrap to two lines if the finish value exceeds the maximum column width.

Important Information and Disclaimer:The information provided on this page represents TI's knowledge and belief as of the date that it is provided. TI bases its knowledge and belief on information provided by third parties, and makes no representation or warranty as to the accuracy of such information. Efforts are underway to better integrate information from third parties. TI has taken and

continues to take reasonable steps to provide representative and accurate information but may not have conducted destructive testing or chemical analysis on incoming materials and chemicals. TI and TI suppliers consider certain information to be proprietary, and thus CAS numbers and other limited information may not be available for release.

In no event shall TI's liability arising out of such information exceed the total purchase price of the TI part(s) at issue in this document sold by TI to Customer on an annual basis.

TAPE AND REEL INFORMATION

QUADRANT ASSIGNMENTS FOR PIN 1 ORIENTATION IN TAPE



*All dimensions are nominal

Device	Package Type	Package Drawing	Pins	SPQ	Reel Diameter (mm)	Reel Width W1 (mm)	A0 (mm)	B0 (mm)	K0 (mm)	P1 (mm)	W (mm)	Pin1 Quadrant
TXB0304RSVR	UQFN	RSV	16	3000	177.8	12.4	2.0	2.8	0.7	4.0	12.0	Q1
TXB0304RUTR	UQFN	RUT	12	3000	180.0	8.4	1.95	2.3	0.75	4.0	8.0	Q1
TXB0304RUTR	UQFN	RUT	12	3000	180.0	9.5	1.9	2.3	0.75	4.0	8.0	Q1
TXBN0304RSVR	UQFN	RSV	16	3000	177.8	12.4	2.0	2.8	0.7	4.0	12.0	Q1
TXBN0304RSVR	UQFN	RSV	16	3000	330.0	12.4	2.1	2.9	0.75	4.0	12.0	Q1
TXBN0304RUTR	UQFN	RUT	12	3000	180.0	8.4	1.95	2.3	0.75	4.0	8.0	Q1

TAPE AND REEL BOX DIMENSIONS

*All dimensions are nominal

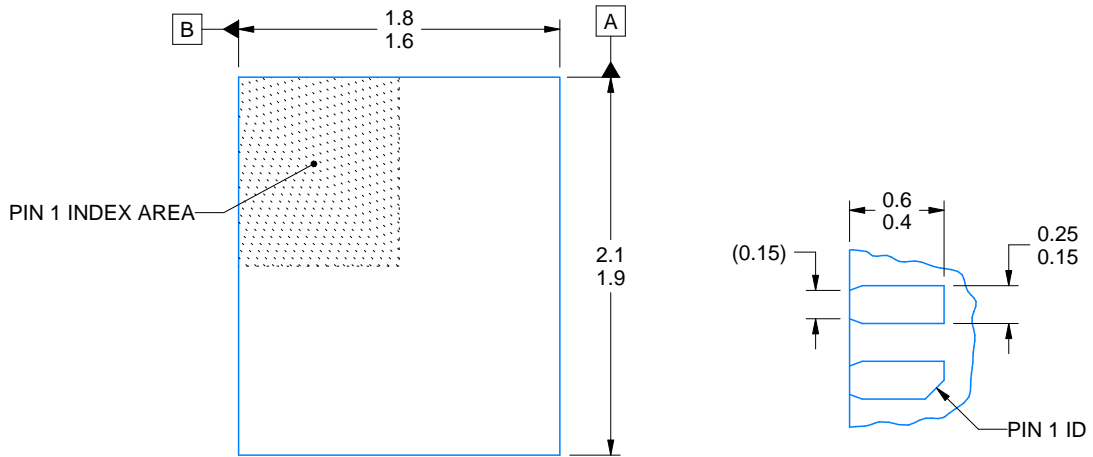
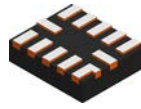
Device	Package Type	Package Drawing	Pins	SPQ	Length (mm)	Width (mm)	Height (mm)
TXB0304RSVR	UQFN	RSV	16	3000	202.0	201.0	28.0
TXB0304RUTR	UQFN	RUT	12	3000	202.0	201.0	28.0
TXB0304RUTR	UQFN	RUT	12	3000	184.0	184.0	19.0
TXBN0304RSVR	UQFN	RSV	16	3000	202.0	201.0	28.0
TXBN0304RSVR	UQFN	RSV	16	3000	184.0	184.0	19.0
TXBN0304RUTR	UQFN	RUT	12	3000	202.0	201.0	28.0



OPTIONAL TERMINAL & PIN 1 ID

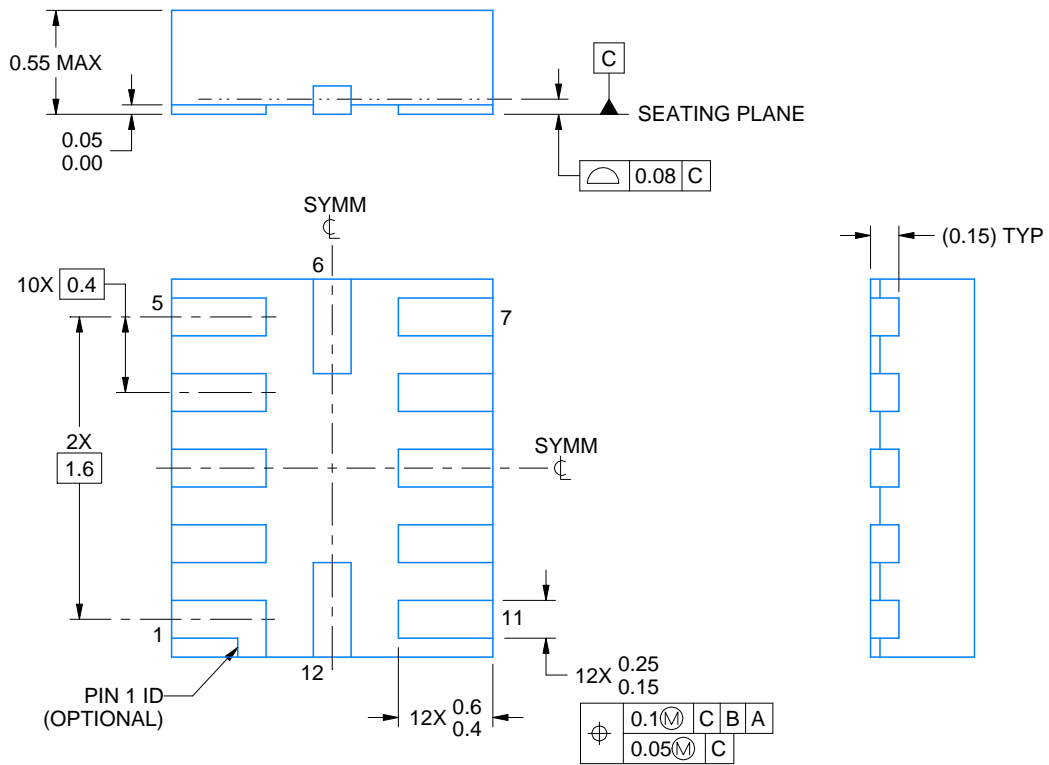

⌀	0.1	C	B	A
	0.05	C		

4220310/A 11/2016

NOTES:

1. All linear dimensions are in millimeters. Any dimensions in parenthesis are for reference only. Dimensioning and tolerancing per ASME Y14.5M.
2. This drawing is subject to change without notice.

EXAMPLE BOARD LAYOUT

RUT0012A

UQFN - 0.55 mm max height

PLASTIC QUAD FLATPACK - NO LEAD

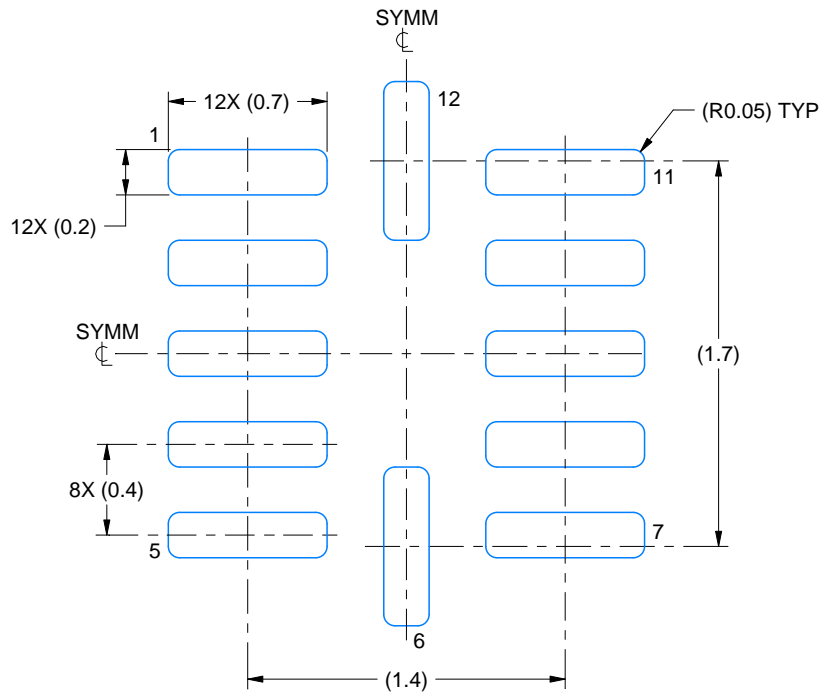

LAND PATTERN EXAMPLE
SCALE:30X

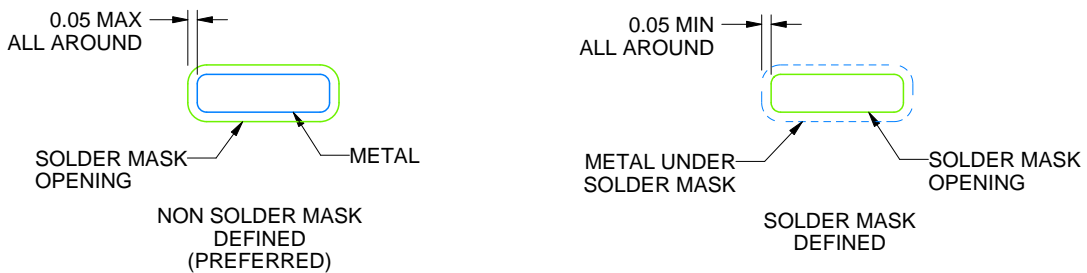

SOLDER MASK DETAILS

4220310/A 11/2016

NOTES: (continued)

3. For more information, see Texas Instruments literature number SLUA271 (www.ti.com/lit/sluea271).

EXAMPLE STENCIL DESIGN

RUT0012A

UQFN - 0.55 mm max height

PLASTIC QUAD FLATPACK - NO LEAD

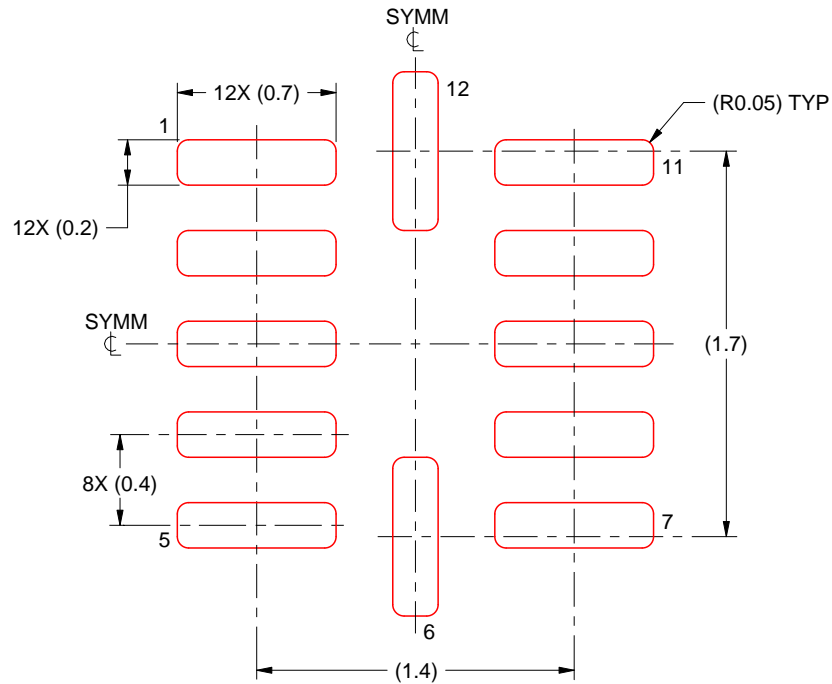

SOLDER PASTE EXAMPLE
BASED ON 0.1 mm THICK STENCIL
SCALE: 30X

4220310/A 11/2016

NOTES: (continued)

4. Laser cutting apertures with trapezoidal walls and rounded corners may offer better paste release. IPC-7525 may have alternate design recommendations.

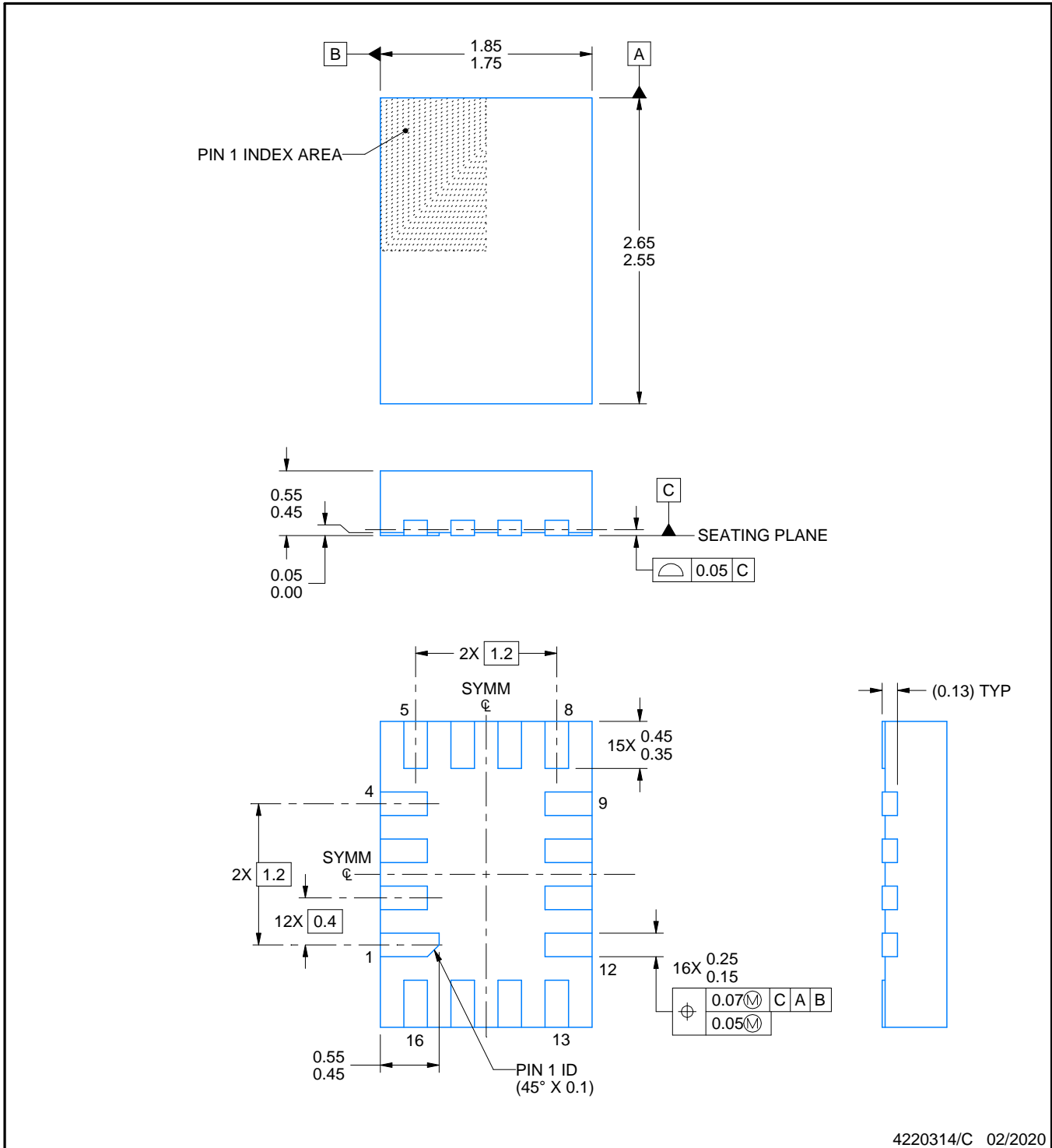
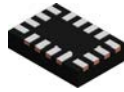

NOTES:

1. All linear dimensions are in millimeters. Any dimensions in parenthesis are for reference only. Dimensioning and tolerancing per ASME Y14.5M.
2. This drawing is subject to change without notice.

EXAMPLE BOARD LAYOUT

RSV0016A

UQFN - 0.55 mm max height

ULTRA THIN QUAD FLATPACK - NO LEAD

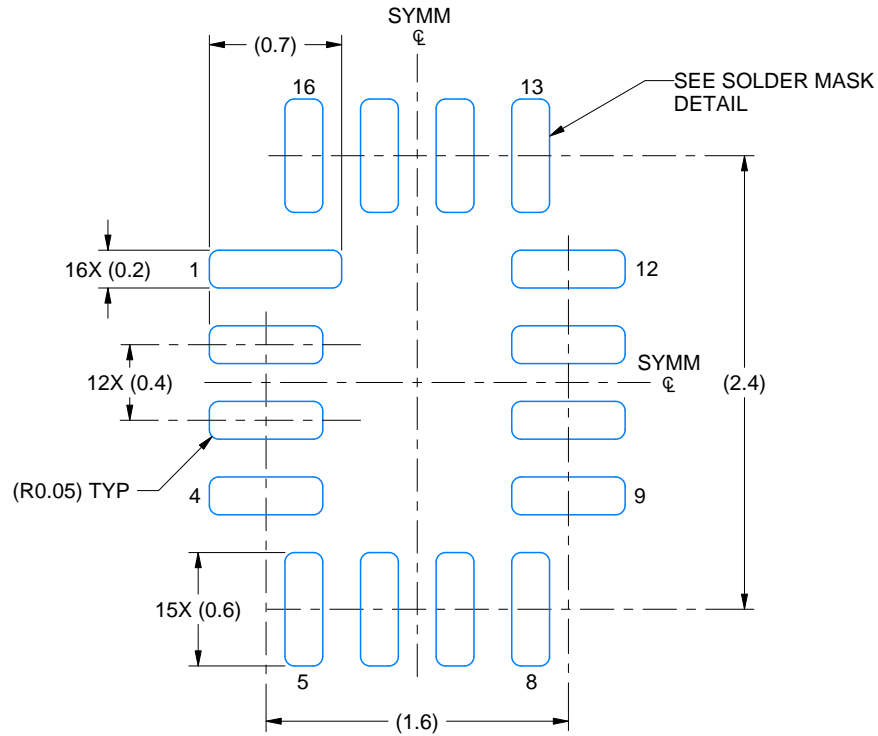

LAND PATTERN EXAMPLE
EXPOSED METAL SHOWN
SCALE: 25X

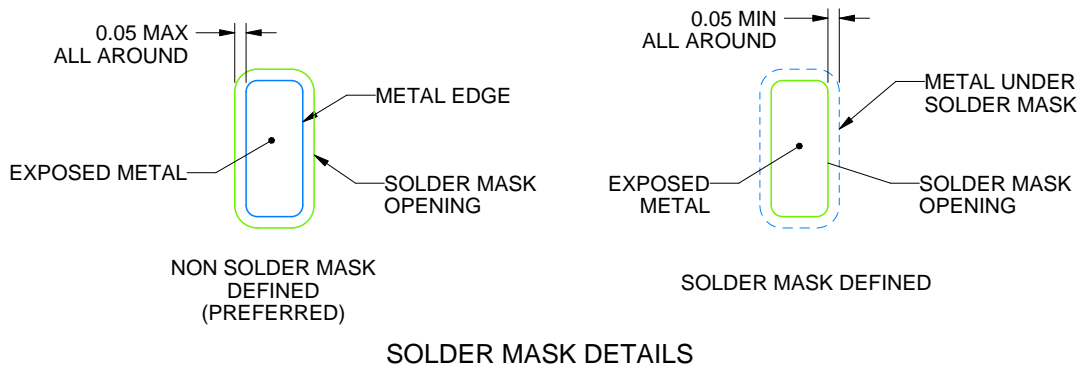

4220314/C 02/2020

NOTES: (continued)

3. For more information, see Texas Instruments literature number SLUA271 (www.ti.com/lit/slua271).

EXAMPLE STENCIL DESIGN

RSV0016A

UQFN - 0.55 mm max height

ULTRA THIN QUAD FLATPACK - NO LEAD

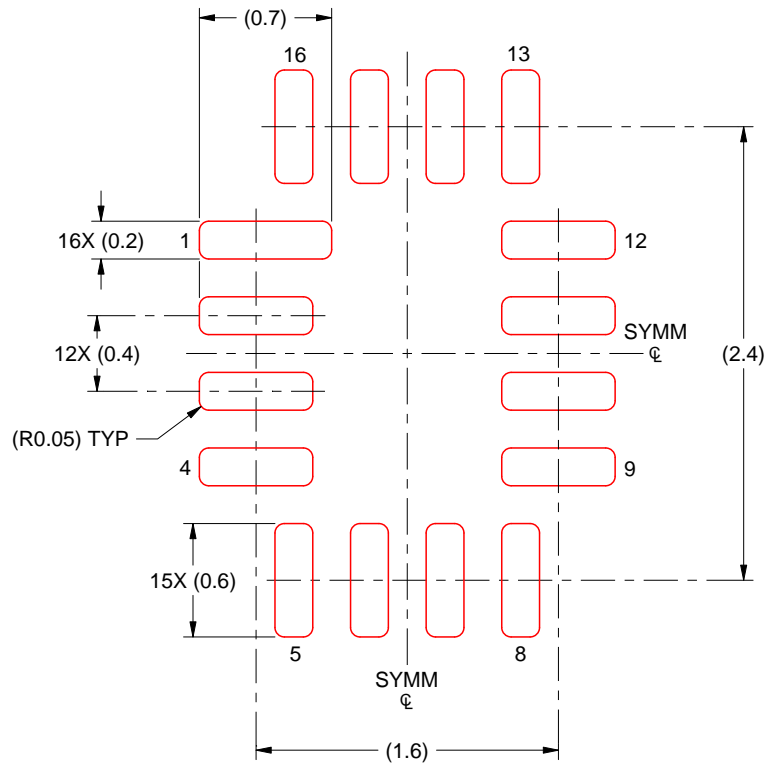

SOLDER PASTE EXAMPLE
BASED ON 0.125 MM THICK STENCIL
SCALE: 25X

4220314/C 02/2020

NOTES: (continued)

4. Laser cutting apertures with trapezoidal walls and rounded corners may offer better paste release. IPC-7525 may have alternate design recommendations.

IMPORTANT NOTICE AND DISCLAIMER

TI PROVIDES TECHNICAL AND RELIABILITY DATA (INCLUDING DATA SHEETS), DESIGN RESOURCES (INCLUDING REFERENCE DESIGNS), APPLICATION OR OTHER DESIGN ADVICE, WEB TOOLS, SAFETY INFORMATION, AND OTHER RESOURCES "AS IS" AND WITH ALL FAULTS, AND DISCLAIMS ALL WARRANTIES, EXPRESS AND IMPLIED, INCLUDING WITHOUT LIMITATION ANY IMPLIED WARRANTIES OF MERCHANTABILITY, FITNESS FOR A PARTICULAR PURPOSE OR NON-INFRINGEMENT OF THIRD PARTY INTELLECTUAL PROPERTY RIGHTS.

These resources are intended for skilled developers designing with TI products. You are solely responsible for (1) selecting the appropriate TI products for your application, (2) designing, validating and testing your application, and (3) ensuring your application meets applicable standards, and any other safety, security, regulatory or other requirements.

These resources are subject to change without notice. TI grants you permission to use these resources only for development of an application that uses the TI products described in the resource. Other reproduction and display of these resources is prohibited. No license is granted to any other TI intellectual property right or to any third party intellectual property right. TI disclaims responsibility for, and you will fully indemnify TI and its representatives against, any claims, damages, costs, losses, and liabilities arising out of your use of these resources.

TI's products are provided subject to [TI's Terms of Sale](#) or other applicable terms available either on [ti.com](https://www.ti.com) or provided in conjunction with such TI products. TI's provision of these resources does not expand or otherwise alter TI's applicable warranties or warranty disclaimers for TI products.

TI objects to and rejects any additional or different terms you may have proposed.

Mailing Address: Texas Instruments, Post Office Box 655303, Dallas, Texas 75265
Copyright © 2024, Texas Instruments Incorporated

Looking for pricing, stock, or lifecycle information?

Click below to explore more details on WIN SOURCE:

 [View TXBN0304RUTR on WIN SOURCE](#)

 [Texas Instruments](#) Information

Optimize Your Supply Chain with WIN SOURCE Solutions

-  Global Sourcing Solution
-  Obsolete Management
-  Cost Control Management
-  Shortage Management
-  Alternative Solution
-  Excess Inventory Management