

TVP5160

NTSC/PAL/SECAM/Component 2x10-Bit Digital Video Decoder

Data Manual



PRODUCTION DATA information is current as of publication date. Products conform to specifications per the terms of the Texas Instruments standard warranty. Production processing does not necessarily include testing of all parameters.

Literature Number: SLES135E
February 2005–Revised April 2011

Contents

1	Introduction	9
1.1	Features	9
1.2	Applications	9
1.3	Description	9
1.4	Related Products	12
1.5	Trademarks	12
1.6	Document Conventions	12
1.7	Ordering Information	12
1.8	Functional Block Diagram	13
1.9	Terminal Assignments	14
2	Functional Description	17
2.1	Analog Processing and A/D Converters	17
2.1.1	Video Input Switch Control	18
2.1.2	480p and 576p Component YPbPr	18
2.1.3	Analog Input Clamping	18
2.1.4	Automatic Gain Control	18
2.1.5	Analog Video Output	18
2.1.6	A/D Converters	19
2.2	Digital Video Processing	19
2.2.1	2x Decimation Filter	19
2.2.2	Composite Processor	19
2.2.3	Color Low-Pass Filter	19
2.2.4	Y/C Separation	20
2.2.5	3D Frame Recursive Noise Reduction	20
2.2.6	Time Base Corrector	20
2.2.7	IF Compensation	20
2.2.8	Luminance Processing	21
2.2.9	Color Transient Improvement	21
2.3	Clock Circuits	22
2.4	Real-Time Control (RTC)	22
2.5	Output Formatter	23
2.6	Fast Switches for SCART and Digital Overlay	24
2.7	Discrete Syncs	26
2.8	Embedded Syncs	31
2.9	I ² C Host Interface	32
2.9.1	Reset and I ² C Bus Address Selection	32
2.9.2	I ² C Operation	33
2.9.3	VBUS Access	33
2.9.3.1	VBUS Write	34
2.9.3.2	VBUS Read	34
2.10	VBI Data Processor	34
2.10.1	VBI FIFO and Ancillary Data in Video Stream	35
2.10.2	VBI Raw Data Out	36
2.11	Powerup, Reset, and Initialization	36
2.12	Adjusting External Syncs	37

3	Internal Control Registers	38
3.1	Register Definitions	43
3.2	VBUS Register Definitions	88
4	Typical Application Circuit	95
4.1	Typical Application Circuit	95
5	Typical Register Programming Sequence	96
6	Electrical Specifications	97
6.1	Absolute Maximum Ratings	97
6.2	Recommended Operating Conditions	97
6.3	Crystal Specifications	98
6.4	DC Electrical Characteristics	98
6.5	Analog Processing and A/D Converters	99
6.6	Data Clock, Video Data, Sync Timing	99
6.7	I ² C Host Port Timing	100
6.8	SDRAM Timing	101
6.9	Example SDRAM Timing Alignment	102
6.10	Memories Tested	103
6.11	Thermal Specification	103
7	Designing With PowerPAD™	104
8	Revision History	106

List of Figures

1-1	TVP5160 PNP-Package Terminal Diagram	15
2-1	Analog Processors and A/D Converters	18
2-2	Luminance Edge-Enhancer Peaking Block	21
2-3	Peaking Filter Frequency Response NTSC/PAL ITU_R BT.601 Sampling.....	21
2-4	Reference Clock Configuration	22
2-5	RTC Timing	23
2-6	Fast-Switches for SCART and Digital Overlay	25
2-7	Vertical Synchronization Signals for 525-Line System	28
2-8	Vertical Synchronization Signals for 625-Line System	28
2-9	Horizontal Synchronization Signals for 10-Bit 4:2:2 Mode.....	29
2-10	Horizontal Synchronization Signals for 20-Bit 4:2:2 Mode.....	30
2-11	VS Position With Respect to HS for Interlaced Signals	31
2-12	VS Position With Respect to HS for Progressive Signals.....	31
2-13	VBUS Access	33
2-14	Reset Timing	37
3-1	Teletext Filter Function	80
4-1	Application Example	95
6-1	Clocks, Video Data, and Sync Timing	100
6-2	I ² C Host Port Timing.....	100
6-3	SDRAM Interface Timing	101
6-4	TVP5160 Timing Relationship with K4S161622E-80 SDRAM.....	102
7-1	128-Pin PowerPAD Package.....	105

List of Tables

1-1	Terminal Functions	15
2-1	Y/C Separation Support by Video Standard	20
2-2	Output Format	23
2-3	Summary of Line Frequency, Data Rate, and Pixel/Line Counts	24
2-4	Fast-Switch Modes	25
2-5	Look-Up Table for Converting from Digital RGB to 10-Bit YCbCr Data	26
2-6	EAV and SAV Sequence	32
2-7	I ² C Host Interface Terminal Description	32
2-8	I ² C Host Interface Device Addresses	32
2-9	Supported VBI System	34
2-10	Ancillary Data Format and Sequence	35
2-11	Reset Sequence	36
3-1	I ² C Registers Summary	38
3-2	VBUS Registers Summary	42
3-3	Input/Output Select	43
3-4	Analog Channel and Video Mode Selection	43
3-5	AFE Gain Control	44
3-6	Video Standard Select	44
3-7	Operation Mode	44
3-8	Autoswitch Mask	45
3-9	Color Killer	45
3-10	Luminance Processing Control 1	46
3-11	Luminance Processing Control 2	46
3-12	Luminance Processing Control 3	47
3-13	Luminance Brightness	47
3-14	Luminance Contrast	47
3-15	Chrominance Saturation	48
3-16	Chroma Hue	48
3-17	Chrominance Processing Control 1	49
3-18	Chrominance Processing Control 2	50
3-19	R/Pr Saturation	50
3-20	G/Y Saturation	50
3-21	B/Pb Saturation	51
3-22	G/Y Brightness	51
3-23	AVID Start Pixel	51
3-24	AVID Stop Pixel	52
3-25	HS Start Pixel	52
3-26	HS Stop Pixel	52
3-27	VS Start Line	52
3-28	VS Stop Line	53
3-29	VBLK Start Line	53
3-30	VBLK Stop Line	53
3-31	Embedded Sync Offset Control 1	53
3-32	Embedded Sync Offset Control 2	54
3-33	Fast-Switch Control	54
3-34	Fast-Switch Overlay Delay	55
3-35	Fast-Switch SCART Delay	55

3-36	Overlay Delay	55
3-37	SCART Delay	56
3-38	CTI Control	56
3-39	Brightness and Contrast Range Extender	56
3-40	Component Autoswitch Mask	57
3-41	Sync Control	57
3-42	Output Formatter Control 1	58
3-43	Output Formatter Control 2	58
3-44	Output Formatter Control 3	59
3-45	Output Formatter Control 4	59
3-46	Output Formatter Control 5	60
3-47	Output Formatter Control 6	60
3-48	Clear Lost Lock Detect	61
3-49	Status 1	61
3-50	Status 2	62
3-51	AGC Gain Status	62
3-52	Video Standard Status	63
3-53	GPIO Input 1	63
3-54	GPIO Input 2	64
3-55	Back End AGC Status 1	64
3-56	AFE Coarse Gain for CH 1	64
3-57	AFE Coarse Gain for CH 2	65
3-58	AFE Coarse Gain for CH 3	65
3-59	AFE Coarse Gain for CH 4	65
3-60	AFE Fine Gain for B/Pb	66
3-61	AFE Fine Gain for G/Y/Chroma	66
3-62	AFE Fine Gain for R/Pr	66
3-63	AFE Fine Gain for CVBS/Luma	67
3-64	656 Version	67
3-65	SDRAM Control	67
3-66	3DNR Y Noise Sensitivity	68
3-67	3DNR UV Noise Sensitivity	68
3-68	3DNR Y Coring Threshold Limit	68
3-69	3DNR UV Coring Threshold Limit	68
3-70	3DNR Low Noise Limit	68
3-71	"Blue" Screen Y Control	68
3-72	"Blue" Screen Cb Control	68
3-73	"Blue" Screen Cr Control	69
3-74	"Blue" Screen LSB Control	69
3-75	Noise Measurement	69
3-76	3DNR Y Core0	69
3-77	3DNR UV Core0	69
3-78	F- and V-Bit Decode Control	70
3-79	Back-End AGC Control	71
3-80	AGC Decrement Speed	71
3-81	ROM Version	71
3-82	RAM Version MSB	71
3-83	AGC White Peak Processing	72

3-84	F-Bit and V-Bit Control	72
3-85	AGC Increment Speed	73
3-86	AGC Increment Delay	73
3-87	Analog Output Control 1	73
3-88	Chip ID MSB	73
3-89	Chip ID LSB	73
3-90	RAM Version LSB	74
3-91	Color PLL Speed Control	74
3-92	3DYC Luma Coring LSB	74
3-93	3DYC Chroma Coring LSB	74
3-94	3DYC Luma/Chroma Coring MSB	74
3-95	3DYC Luma Gain	75
3-96	3DYC Chroma Gain	75
3-97	3DYC Signal Quality Gain	75
3-98	3DYC Signal Quality Coring	75
3-99	IF Compensation Control	76
3-100	IF Differential Gain Control	76
3-101	IF Low Frequency Gain Control	76
3-102	IF High Frequency Gain Control	76
3-103	Weak Signal High Threshold	76
3-104	Weak Signal High Threshold	77
3-105	Status Request	77
3-106	3DYC NTSC VCR Threshold	77
3-107	3DYC PAL VCR Threshold	77
3-108	Vertical Line Count	77
3-109	AGC Decrement Delay	78
3-110	VDP TTX Filter and Mask	78
3-111	VDP TTX Filter Control	79
3-112	VDP FIFO Word Count	80
3-113	VDP FIFO Interrupt Threshold	81
3-114	VDP FIFO Reset	81
3-115	VDP FIFO Output Control	81
3-116	VDP Line Number Interrupt	81
3-117	VDP Pixel Alignment	82
3-118	VDP Line Start	82
3-119	VDP Line Stop	82
3-120	VDP Global Line Mode	82
3-121	VDP Full Field Enable	82
3-122	VDP Full Field Mode	83
3-123	Interlaced/Progressive Status	83
3-124	VBUS Data Access with No VBUS Address Increment	83
3-125	VBUS Data Access with VBUS Address Increment	83
3-126	VDP FIFO Read Data	83
3-127	VBUS Address	84
3-128	Interrupt Raw Status 0	84
3-129	Interrupt Raw Status 1	85
3-130	Interrupt Status 0	85
3-131	Interrupt Status 1	86

3-132	Interrupt Mask 0	86
3-133	Interrupt Mask 1	86
3-134	Interrupt Clear 0	87
3-135	Interrupt Clear 1	87
3-136	VDP Closed Caption Data	88
3-137	VDP WSS/CGMS Data	88
3-138	VDP VITC Data	89
3-139	VDP V-Chip TV Rating Block 1	89
3-140	VDP V-Chip TV Rating Block 2	89
3-141	VDP V-Chip TV Rating Block 3	90
3-142	VDP V-Chip MPAA Rating Data	90
3-143	VDP General Line Mode and Line Address	91
3-144	VDP VPS, Gemstar EPG Data	92
3-145	Analog Output Control 2	93
3-146	Interrupt Configuration	93
3-147	Interrupt Raw Status 1	93
3-148	Interrupt Status 1	94
3-149	Interrupt Mask 1	94
3-150	Interrupt Clear 1	94
6-1	Memories Tested	103
8-1	Revision History	106

NTSC/PAL/SECAM/Component 2x10-Bit Digital Video Decoder

Check for Samples: [TVP5160](#)

1 Introduction

1.1 Features

- Two 11-Bit 60-MSPS Analog-to-Digital (A/D) Converters With Analog Preprocessors (Clamp/AGC)
- Fixed RGB-to-YUV Color Space Conversion
- Robust Sync Detection for Weak and Noisy Signals as Well as VCR
- Supports NTSC (J, M, 4.43), PAL (B, D, G, H, I, M, N, Nc, 60) and SECAM (B, D, G, K, K1, L) CVBS, S-Video
- Supports Component Standards 480i, 576i, 480p, and 576p
- Supports ITU-R BT.601 Pixel Sampling Frequencies
- Supports 3D Y/C Separation, or 2D 5-Line (5H) Adaptive Comb and Chroma Trap Filter for Both PAL and NTSC Signals
- Concurrent Temporal, Frame Recursive, Noise Reduction (3DNR)
- IF Compensation
- Line-Based Time Base Correction (TBC)
- Fast Switch 4x Oversampled Input for Digital RGB Overlay Switching Between Any CVBS, S-Video, or Component Video Input
- SCART 4x Oversampled Fast Switching Between Component RGB Input and CBVS Input
- Analog Video Output
- Chrominance Processor
- Luminance Processor
- Clock/Timing Processor and Power-Down Control
- Output Formatter Supports Both ITU-R BT.656 (Embedded Syncs) and ITU-R BT.601 (4:2:2 With Discrete Syncs)
- I²C Host Port Interface
- VBI Data Processor
- "Blue" Screen (Programmable Color) Output
- Macrovision™ Copy Protection Detection Circuit (Types 1, 2, and 3) on Both Interlaced and Progressive Signals

1.2 Applications

- Digital TV
- LCD TV/Monitors
- DVD-R
- PVR
- PC Video Cards
- Video Capture/Video Editing
- Video Conferencing

1.3 Description

The TVP5160 device is a high quality, digital video decoder that digitizes and decodes all popular baseband analog video formats into digital component video. The TVP5160 decoder supports the A/D conversion of component YPbPr and RGB (SCART) signals, as well as the A/D conversion and decoding of NTSC, PAL, and SECAM composite and S-Video into component YCbCr. Additionally, component progressive signals can be digitized. The chip includes two 11-bit, 60-MSPS, A/D converters (ADCs). Prior to each ADC, each analog channel contains an analog circuit, which clamps the input to a reference voltage and applies a programmable gain and offset. A total of 12 video input terminals can be configured to a combination of YPbPr, RGB, CVBS, and S-Video video inputs.

Progressive component signals are sampled at 2× clock frequency (54 MHz) and are then decimated to the 1× rate. In SCART mode the component inputs and the CVBS inputs are sampled at 54 MHz



Please be aware that an important notice concerning availability, standard warranty, and use in critical applications of Texas Instruments semiconductor products and disclaimers thereto appears at the end of this data sheet.

alternately, then decimated to the 1× rate. Composite or S-Video signals are sampled at 4× the ITU-R BT.601 clock frequency (54 MHz), line-locked for correct pixel alignment, and are then decimated to the 1× rate. CVBS decoding uses advanced 3D Y/C filtering and 2-dimensional complementary 5-line adaptive comb filtering for both the luma and chroma data paths to reduce both cross-luma and cross-chroma artifacts. 3D Y/C color separation may be used on both PAL and NTSC video signals. A chroma trap filter is also available. On CVBS and Y/C inputs, the user can control video characteristics such as hue, contrast, brightness, and saturation via an I²C host port interface. Furthermore, luma peaking with programmable gain is included, as well as a patented color transient improvement (CTI) circuit. Attenuation at higher frequencies or asymmetrical color subcarrier sidebands are compensated using the IF compensation block. Frame adaptive noise reduction may be applied to reduce temporal noise on CVBS, S-Video, or component inputs.

3D noise reduction and 3D Y/C separation may be used at the same time or independently.

The TVP5160 decoder uses Texas Instruments' patented technology for locking to weak, noisy, or unstable signals and can auto-detect between broadcast quality and VCR-style (nonstandard) video sources.

The TVP5160 decoder generates synchronization, blanking, field, active video window, horizontal and vertical syncs, clock, genlock (for downstream video encoder synchronization), host CPU interrupt and programmable logic I/O signals, in addition to digital video outputs.

The TVP5160 decoder includes methods for advanced vertical blanking interval (VBI) data retrieval. The VBI data processor (VDP) slices and performs error checking on teletext, closed caption, and other VBI data. A built-in FIFO stores up to 11 lines of teletext data, and, with proper host port synchronization, full-screen teletext retrieval is possible. The TVP5160 decoder can pass through the output formatter 2× sampled raw Luma data for host-based VBI processing.

Digital RGB overlay can be synchronously switched with any video input, with all signals being oversampled at 4× the pixel rate.

The TVP5160 detailed functionality includes:

- Two high-speed, 60-MSPS, 11-bit, A/D channels with programmable clamp and gain control
The two ADCs can sample CVBS or S-Video at 54 MHz. YPbPr/RGB is multiplexed between the two ADCs which sample at 54 MHz giving a channel sampling frequency of 27 MHz.
- Supports ITU-R BT.601 pixel sampling frequencies.
Supports ITU-R BT.601 sampling for both interlaced and progressive signals.
- RGB-to-YUV color space conversion for SCART signals
- 3D Y/C separation or 2D 5-line (5H) adaptive comb and chroma trap filter
3-frame NTSC and PAL color separation
- Temporal frame recursive noise reduction (3DNR)
Frame recursive noise reduction can be applied to interlaced CVBS, S-Video, or component inputs for interlaced signals. Noise reduction can be used at the same time as 3D Y/C separation. Noise reduction cannot be applied to progressive video signals.
- Line-based time base correction (TBC)
Line-based time correction corrects for horizontal phase errors encountered during video decoding up to ±80 pixels of error. This improves the output video quality from jittery sources such as VCRs. It also reduces line tearing during video trick modes such as fast forward and rewind.
- IF compensation
Attenuation at higher frequencies or asymmetrical color subcarrier sidebands are compensated using the IF compensation block
- Fast switch 4× oversampling for digital RGB overlay signals for switching between any CVBS, S-Video, or component video inputs
The fast switch overlay signals (FSO, DR, DG, DB) are oversampled at 4× the pixel clock frequency. The phase of these signals is used to mix the selected video input format and a digital RGB input to

generate an output video stream. This improves the overlay picture quality when the external FSO and digital RGB signals are generated by an asynchronous source.

- SCART 4x oversampled fast switching between component RGB input and CBVS input
The SCART overlay control signal (FSS) is oversampled at 4x the pixel clock frequency. The phase of this signal is used to mix between the CVBS input and the analog RGB inputs. This improves the analog overlay picture quality when the external FSS and analog video signals are generated by an asynchronous source.
- Analog video output
Buffered analog output with automatic PGA
- Supports NTSC (J, M, 4.43), PAL (B, D, G, H, I, M, N, Nc, 60), SECAM (B, D, G, K, K1, L), CVBS, and S-Video
- Twelve analog video input terminals for multi-source connection
- User-programmable video output formats
 - 10-bit ITU-R BT.656 4:2:2 YCbCr with embedded syncs
 - 20-bit 4:2:2 YCbCr with discrete syncs
 - 10-bit 4:2:2 YCbCr with discrete syncs
 - 2× sampled raw VBI data in active video during a vertical blanking period
 - Sliced VBI data during a horizontal blanking period
- HS/VS outputs with programmable position, polarity, and width and FID (Field ID) output
- Composite and S-Video processing
 - Adaptive 3D/2D Y/C separation using 5-line adaptive comb filter for composite video inputs; chroma-trap available
 - Automatic video standard detection and switching (NTSC/PAL/SECAM/progressive)
 - Luma-peaking with programmable gain
 - Output data rates either 1× or 2× pixel rate
 - Patented architecture for locking to weak, noisy, or unstable signals
 - Single 14.31818-MHz reference crystal for all standards (ITU-R.BT601 sampling, interlaced or progressive)
 - Line-locked internal pixel sampling clock generation with horizontal and vertical lock signal outputs
 - Certified Macrovision copy protection detection on composite and S-Video inputs (NTSC, PAL)
 - Genlock output (RTC) for downstream video encoder synchronization
- Vertical blank interval data processor
 - Teletext (NABTS, WST)
 - Closed caption (CC) and extended data service (XDS)
 - Wide screen signaling (WSS)
 - Copy generation management system (CGMS)
 - Video program system (VPS/PDC)
 - Vertical interval time code (VITC)
 - EPG video guide 1×/2× (Gemstar)
 - V-Chip decoding
 - Custom mode
 - Register readback of CC, CGMS, WSS, VPS, VITC, V-Chip, EPG 1× and 2× sliced data, CGMS-A and RC for progressive signals.
- I²C host port interface
- "Blue" screen output
- Macrovision copy protection detection circuit (types 1, 2, and 3) on both interlaced and progressive signals
Macrovision detection on standard definition signals of types 1, 2, and 3, and to Revision 1.2 for

progressive signals

- Reduced power consumption: 1.8-V digital core, 3.3-V and 1.8-V analog core with power-save and power-down modes
- 128-TQFP PowerPAD™ package

1.4 Related Products

- TVP5146M2
- TVP5147M1
- TVP5150AM1
- TVP5151
- TVP5154A
- TVP5158

1.5 Trademarks

- TI and PowerPAD are trademarks of Texas Instruments.
- Macrovision is a trademark of Macrovision Corporation.
- Gemstar is a trademark of Gemstar-TV Guide International.
- Other trademarks are the property of their respective owners

1.6 Document Conventions

Throughout this data manual, several conventions are used to convey information. These conventions are listed below:

1. To identify a binary number or field, a lower case b follows the numbers. For example: 000b is a 3-bit binary field.
2. To identify a hexadecimal number or field, a lower case h follows the numbers. For example: 8AFh is a 12-bit hexadecimal field.
3. All other numbers that appear in this document that do not have either a b or h following the number are assumed to be decimal format.
4. If the signal or terminal name has a bar above the name (for example, $\overline{\text{RESETB}}$), then this indicates the logical NOT function. When asserted, this signal is a logic low, 0, or 0b.
5. RSVD indicates that the referenced item is reserved.

1.7 Ordering Information⁽¹⁾

T _A	PACKAGED DEVICES ⁽²⁾	PACKAGE OPTION
	128-PIN TQFP PowerPAD™	
0°C to 70°C	TVP5160PNP	Tray

(1) For the most current package and ordering information, see the Package Option Addendum at the end of this document, or see the TI web site at www.ti.com.

(2) Package drawings, thermal data, and symbolization are available at www.ti.com/packaging.

1.8 Functional Block Diagram

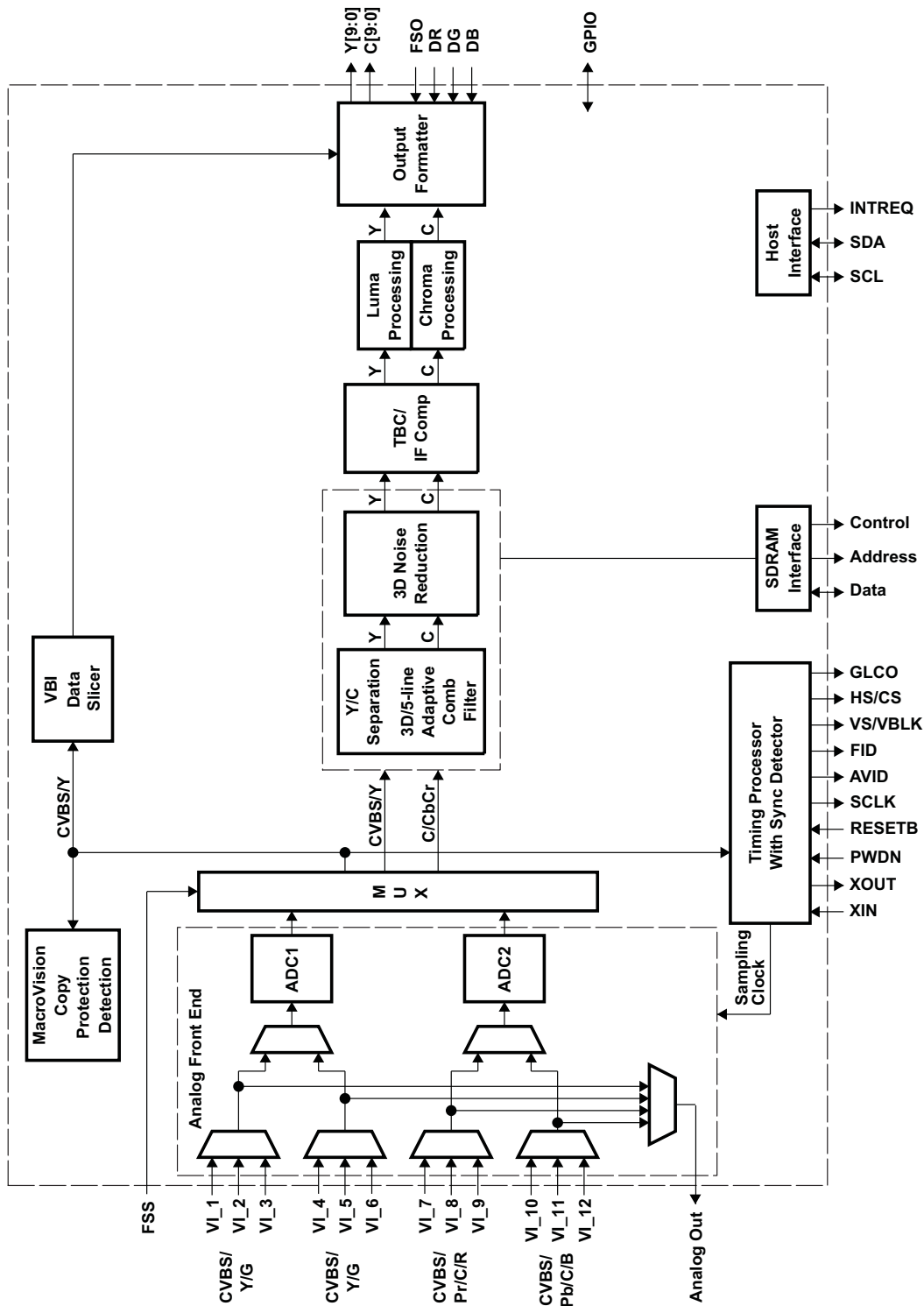

Table 1-1. Terminal Functions

PIN		I/O	DESCRIPTION
NAME	NO.		
Analog Video			
VI_1	3	I	VI_x: analog video inputs Up to 12 composite, 6 S-Video, or 3 component video inputs (or combinations thereof) can be supported. Also, 4-channel SCART is supported. The inputs must be ac-coupled. The recommended coupling capacitor is 0.1 μ F. The possible input configurations are listed in the input select register 00h. Unused inputs must be connected to ground through 0.1- μ F capacitors.
VI_2	4		
VI_3	5		
VI_4	7		
VI_5	8		
VI_6	9		
VI_7	17		
VI_8	18		
VI_9	19		
VI_10	21		
VI_11	22		
VI_12	23		
Analog_out	127	O	Unbuffered analog video output
Clock Signals			
XIN	121	I	External clock reference input. It may connected to external oscillator with 1.8-V compatible clock signal or 14.31818-MHz crystal oscillator.
XOUT	122	O	External clock reference output. Not connected if XTAL1 is driven by an external single-ended oscillator.
SCLK	84	O	Line-locked data output clock
Digital Video			
Y[9:0]	87–91, 94–98	O	Digital video output of Y/YCbCr, Y_9 is MSB and Y_0 is LSB. For 8-bit operation, the upper 8 bits must be connected.
C[9:0] / GPIO	101–104, 107–110, 113, 114	I/O	Digital video output of CbCr, C_9 is MSB and C_0 is LSB. These terminals can be programmable general purpose I/O, or as digital overlay controls. For 8-bit operation, the upper 8 bits must be connected.
FSO	101	I	Fast-switch overlay between digital RGB and any video input
DB	102	I	Digital BLUE input from overlay device
DG	103	I	Digital GREEN input from overlay device
DR	104	I	Digital RED input from overlay device Unused GPIO pins must be either configured as outputs, or tied to either IOVDD or DGND
Miscellaneous Signals			
RESETB	36	I	Reset input, active low
PWDN	35	I	Power down input 1 = Power down 0 = Normal mode
GLCO / GPIO / I2CA0	83	I/O	Genlock control output (GLCO). Supports the real-time control (RTC) format. This pin can also be configured as a general-purpose I/O (GPIO). During power on reset this pin is sampled along with pin 82 (I2CA1) as an input to determine the I ² C address the device will be configured to. A 10-k Ω resistor pulls this either high (to IOVDD) or low to select between addresses.
GPIO / I2CA1	82	I/O	Programmable general purpose I/O During power on reset this pin is sampled along with pin 83 (I2CA0) as an input to determine the I ² C address the device will be configured to. A 10-k Ω resistor pulls this either high (to IOVDD) or low to select between addresses.
INTREQ	32	O	Interrupt request output (open drain when programmed to be active low)
FSS	119	I	SCART fast switch input
NC	6, 10, 20, 24	N/A	No internal connection. Connect to AGND through 0.1- μ F capacitors for future compatibility.
Host Interface			
SDA	31	I/O	I ² C data bus
SCL	30	I/O	I ² C clock input

Table 1-1. Terminal Functions (continued)

PIN		I/O	DESCRIPTION
NAME	NO.		
Power Supplies			
A33GND	1, 26, 27, 28, 126, 128	P	Analog 3.3-V return. Connect to analog ground.
A33VDD	2, 25, 125	P	Analog power. Connect to analog 3.3-V supply.
A18GND	12, 14, 15	P	Analog 1.8-V return. Connect to analog ground.
A18VDD	11, 13, 16	P	Analog power. Connect to analog 1.8-V supply.
PLL18GND	124	P	Analog power return. Connect to analog ground.
PLL18VDD	123	P	Analog power. Connect to analog 1.8-V supply.
DGND	29, 34, 48,66, 86, 100,112, 120	P	Digital return. Connect to digital ground.
DVDD	33, 47, 65,85, 99, 111	P	Digital core power. Connect to 1.8-V supply.
IOGND	38, 58, 75,93, 106	P	Digital power return. Connect to digital ground.
IOVDD	37, 57, 74,92, 105	P	Digital I/O power. Connect to digital 3.3-V supply.
Sync Signals			
HS / CS / GPIO	117	I/O	Horizontal sync output or digital composite sync output Programmable general purpose I/O Unused GPIO pins must be either configured as outputs, or tied to either IOVDD or DGND
VS / VBLK / GPIO	118	I/O	Vertical sync output. (for modes with dedicated VS) or vertical blanking output Programmable general purpose I/O Unused GPIO pins must be either configured as outputs, or tied to either IOVDD or DGND
FID / GPIO	116	I/O	Odd/even field indicator Programmable general purpose I/O This pin must be pulled low through a 10-kΩ resistor for correct device operation.
AVID / GPIO	115	I/O	Active video indicator Programmable general purpose I/O Unused GPIO pins must be either configured as outputs, or tied to either IOVDD or DGND
SDRAM Interface			
Address[11:0]	61, 77, 62–64, 67–69, 81–78	O	SDRAM address bus
D[15:0]	49–56, 46–39	I/O	SDRAM data bus
\overline{WE}	70	O	SDRAM write enable
\overline{CAS}	71	O	SDRAM CAS enable
\overline{RAS}	72	O	SDRAM RAS enable
DQM	59	O	SDRAM input/output mask for data
BA[1:0]	76, 73	O	SDRAM bank address
SDRAM_CLK	60	O	SDRAM 108-MHz clock

2 Functional Description

2.1 Analog Processing and A/D Converters

Figure 2-1 shows a functional diagram of the analog processors and A/D converters (ADCs). This block provides the analog interface to all video inputs. It accepts up to 12 inputs and performs source selection, video clamping, video amplification, A/D conversion, and gain and offset adjustments to center the digitized video signal. The TVP5160 decoder supports one analog video output.

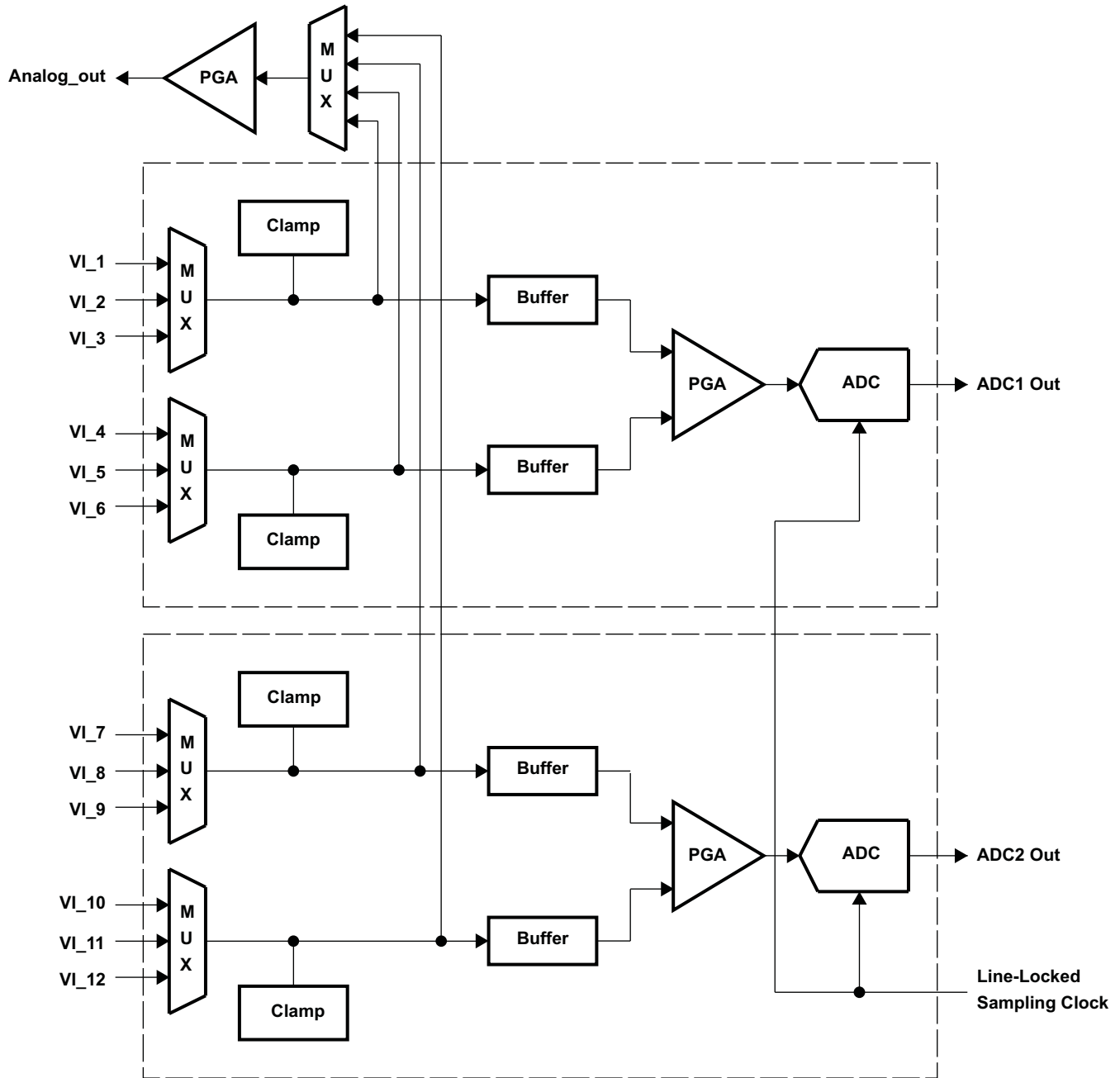

Figure 2-1. Analog Processors and A/D Converters

2.1.1 Video Input Switch Control

The TVP5160 decoder has two analog channels that accept up to 12 video inputs. The user can configure the internal analog video switches via I²C. The 12 analog video inputs can be used for different input configurations, some of which are:

- 12 CVBS video inputs
- 4 S-Video inputs and 2 CVBS inputs
- 3 YPbPr video inputs and 3 CVBS input
- 2 YPbPr video inputs, 2 S-Video inputs, and 2 CVBS inputs

The input selection is performed by the input select register at I²C subaddress 00h.

2.1.2 480p and 576p Component YPbPr

The TVP5160 decoder supports progressive component video inputs. The YPbPr inputs of the TVP5160 decoder may accept 480p or 576p progressive inputs. The Y channel is fed into one ADC while PbPr are sampled alternatively by the other ADC.

2.1.3 Analog Input Clamping

An internal clamping circuit restores the ac-coupled video signal to a fixed dc level. The clamping circuit provides line-by-line restoration of the video sync level to a fixed dc reference voltage. The selection between bottom and mid clamp is performed automatically by the TVP5160 decoder.

2.1.4 Automatic Gain Control

The TVP5160 decoder uses two programmable gain amplifiers (PGAs); one per channel. The PGA can scale a signal with a voltage input compliance of 0.5 V_{PP} to 2.0 V_{PP} to a full-scale, 11-bit, A/D output code range. A 4-bit code sets the coarse gain with individual adjustment per channel. Minimum gain corresponds to a code 0x0 (2.0-V_{PP} full-scale input, -6 dB gain) while maximum gain corresponds to code 0xF (0.5-V_{PP} full scale, +6 dB gain). The TVP5160 decoder also has 12-bit fine gain controls for each channel and applies independently to coarse gain controls. For composite video, the input video signal amplitude may vary significantly from the nominal level of 1 V_{PP}. The TVP5160 decoder can adjust its PGA setting automatically: an automatic gain control (AGC) can be enabled and can adjust the signal amplitude such that the maximum input range of the ADC is reached without clipping. Some nonstandard video signals contain peak white levels that saturate the ADC. In these cases, the AGC automatically cuts back gain to avoid clipping. If the AGC is on, then the TVP5160 decoder can read the gain currently being used.

The TVP5160 AGC comprises the front-end AGC before Y/C separation and the back-end AGC after Y/C separation. The back-end AGC restores the optimum system gain whenever an amplitude reference, such as the composite peak (which is only relevant before Y/C separation), forces the front-end AGC to set the gain too low. The front-end and back-end AGC algorithms can use up to four amplitude references: sync height, color burst amplitude, composite peak, and luma peak.

The specific amplitude references being used by the front-end and back-end AGC algorithms can be independently controlled using the AGC white peak processing register located at subaddress 74h. The TVP5160 gain increment speed and gain increment delay can be controlled using the AGC increment speed register located at subaddress 78h and the AGC increment delay register located at subaddress 79h, respectively.

2.1.5 Analog Video Output

Any one of the analog input signals is available at the analog video output pin. The signal at this pin must be buffered by a source follower if it drives a 75-Ω resistor. The nominal output voltage is 2 V_{PP}, and the signal can drive a 75-Ω line when buffered. The magnitude is maintained with a PGA in 16 steps controlled by the TVP5160 decoder.

2.1.6 A/D Converters

All ADCs have a resolution of 11 bits and can operate up to 60 MSPS. All A/D channels receive an identical clock from the on-chip, phase-locked loop (PLL) at a frequency between 24 MHz and 60 MHz. All ADC reference voltages are generated internally.

2.2 Digital Video Processing

This block receives digitized video signals from the ADCs and performs composite processing for CVBS and S-Video inputs, YCbCr signal enhancements for CVBS and S-Video inputs. It also generates horizontal and vertical syncs, and other output control signals such as RTC for CVBS and S-Video inputs. Additionally, it can provide field identification, horizontal and vertical lock, vertical blanking, and active video window indication signals. The digital data output can be programmed to two formats: 20-bit 4:2:2 with external syncs or 10-bit 4:2:2 with embedded/discrete syncs. The circuit detects pseudo sync pulses, AGC pulses and color striping in Macrovision-encoded copy protected material. Information present in the VBI interval can be retrieved and either inserted in the ITU-R.BT656 output as ancillary data or stored in an internal FIFO for retrieval via the I²C interface.

2.2.1 2x Decimation Filter

All input signals are typically oversampled by a factor of 4 (54 MHz). The A/D outputs first pass through decimation filters that reduce the data rate to 1× pixel rate. The decimation filter is a half-band filter. Oversampling and decimation filtering can effectively increase the overall signal-to-noise ratio by 3 dB.

2.2.2 Composite Processor

The TVP5160 digital composite video processing circuit receives a digitized composite or S-Video signal from the ADCs and performs 2D or 3D Y/C separation (bypassed for S-Video input), chroma demodulation for PAL/NTSC and SECAM, and YUV signal enhancements.

2.2.3 Color Low-Pass Filter

High filter bandwidth preserves sharp color transitions and produces crisp color boundaries. However, for nonstandard video sources that have asymmetrical U and V side bands, it is desirable to limit the filter bandwidth to avoid UV crosstalk. The color low-pass filter bandwidth is programmable to enable one of the three notch filters.

2.2.4 Y/C Separation

Y/C separation may be done using 3D or 2D adaptive 5-line (5-H delay) comb filters or chroma trap filter for both NTSC and PAL video standards as shown in [Table 2-1](#). The comb filter can be selectively bypassed in the luma or chroma path. If the comb filter is bypassed in the luma path, then chroma notch filters are used. TI's patented adaptive comb filter algorithm reduces artifacts such as hanging dots at color boundaries. It detects and properly handles false colors in high-frequency luminance images such as a multiburst pattern or circle pattern.

Table 2-1. Y/C Separation Support by Video Standard

Video Standard	2D Y/C	3D Y/C
NTSC-M	Yes	Yes
NTSC-J	Yes	Yes
PAL-B, D, G, H, I	Yes	Yes
PAL-N	Yes	Yes
PAL-M	Yes	No
PAL-Nc	Yes	No
NTSC-4.43, PAL-60	Yes	No
SECAM	No	No

2.2.5 3D Frame Recursive Noise Reduction

The TI proprietary frame recursive noise reduction or 3DNR reduces the level of noise in CVBS, S-Video, or component inputs by comparing multiple frames of data and canceling out the resulting noise. The 3DNR uses the same frame buffer memory used by the 3DYC. The 3DNR may function concurrently with 3DYC.

There are various modes of operation for the 3DNR and 3DYC:

MODES	OPERATION	MEMORY REQUIRED
Mode 0	3DYC + 3DNR	4 MBytes
Mode 1	3DYC only	2 MBytes
Mode 2	2D 5-line CF + 3DNR	2 MBytes
Mode 3	2D only (default)	None

2.2.6 Time Base Corrector

The time base corrector monitors and corrects for horizontal PLL phase offsets up to ± 80 pixels. This improves video decoder output quality by removing artifacts due to jittery horizontal syncs from broadcast stations. It also reduces line tearing during VCR trick modes such as fast forward and rewind. 3DYC, frame recursive noise reduction (3DNR), and time base correction (TBC) can be used simultaneously or independently. Because TBC does not require any external memory, it can be used in all configurations.

2.2.7 IF Compensation

Attenuation of higher frequencies from the tuners input characteristics or due to channels that are not correctly tuned can be corrected in the IF compensation block. This block can correct for uneven sidebands resulting in incorrect and uneven UV demodulation.

2.2.8 Luminance Processing

The luma component is derived from the composite signal by subtracting the remodulated chroma information. The luminance signal is then fed to the input of a peaking circuit. Figure 2-2 illustrates the basic functions of the luminance data path. In the case of S-Video, the luminance signal bypasses the comb filter or chroma trap filter and is fed to the circuit directly. A peaking filter (edge-enhancer) amplifies high frequency components of the luminance signal. Figure 2-3 shows the characteristics of the peaking filter at four different gain settings that are user-programmable by the I²C.

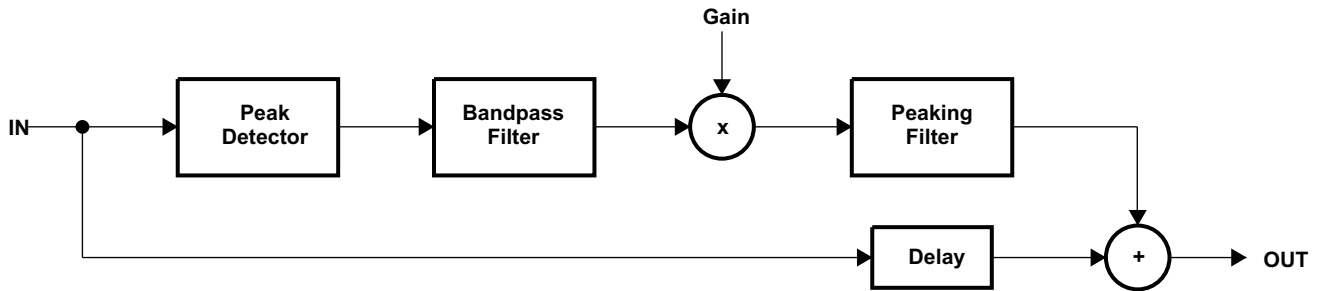

Figure 2-2. Luminance Edge-Enhancer Peaking Block

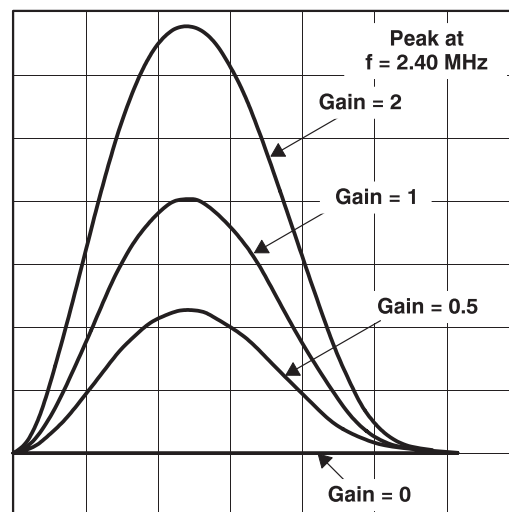

Figure 2-3. Peaking Filter Frequency Response NTSC/PAL ITU_R BT.601 Sampling

2.2.9 Color Transient Improvement

Color transient improvement (CTI) enhances horizontal color transients. The color difference signal transition points are maintained, but the edges are enhanced for signals which have bandwidth limited color components.

2.3 Clock Circuits

An internal line-locked PLL generates the system and pixel clocks. A 14.31818-MHz clock is required to drive the PLL. This may be input to the TVP5160 decoder at 1.8-V level on terminal 121 (XIN), or a crystal of 14.31818-MHz fundamental resonant frequency may be connected across terminals 121 (XIN) and 122 (XOUT). If a parallel resonant circuit is used as shown in Figure 2-4, then the external capacitors must have following relationship:

$$C_{L1} = C_{L2} = 2C_L - C_{STRAY}$$

Where,

C_{STRAY} is the pin capacitance with respect to ground

C_L is the crystal load capacitance specified by the crystal manufacturer

Figure 2-4 shows the reference clock configurations. The TVP5160 decoder generates the SCLK signal used for clocking data.

NOTE

See crystal data sheet for correct loading specifications.

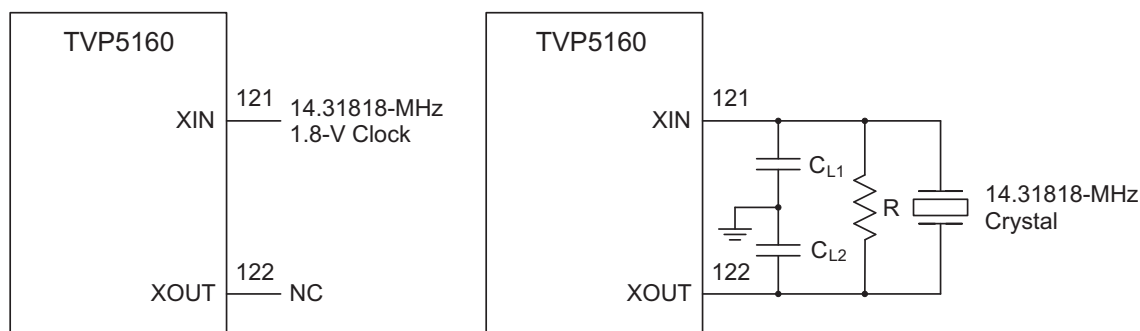

Note: The resistor (R) in parallel with the crystal is recommended to support a wide range of crystal types. A 100-k Ω resistor may be used for most crystal types.

Figure 2-4. Reference Clock Configuration

2.4 Real-Time Control (RTC)

Although the TVP5160 decoder is a line-locked system, the color burst information is used to accurately determine the color subcarrier frequency and phase. This ensures proper operation with nonstandard video signals that do not follow exactly the required frequency multiple between color subcarrier frequency and video line frequency. The frequency control word of the internal color subcarrier PLL and the subcarrier reset bit are transmitted via the terminal 83 (GLCO) for optional use in an end system (for example, by a video encoder). The frequency control word is a 23-bit binary number. The instantaneous frequency of the color subcarrier can be calculated from the following equation:

$$F_{PLL} = \frac{F_{CTRL}}{2^{23}} \times F_{SCLK}$$

where F_{PLL} is the frequency of the subcarrier PLL, F_{CTRL} is the 23-bit PLL frequency control word and F_{SCLK} is the 2 \times pixel frequency.

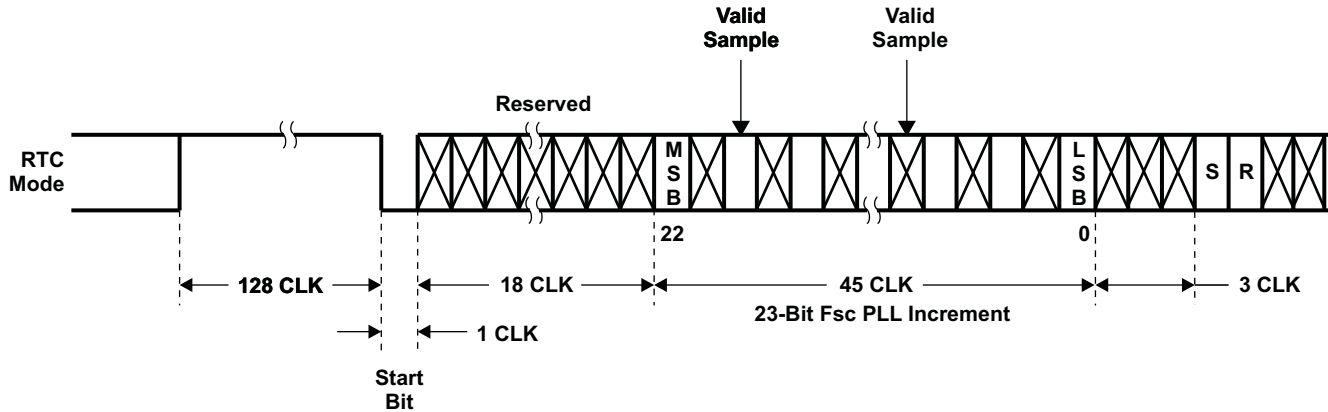

Figure 2-5. RTC Timing

RTC: Reset bit (R) is active low
 Sequence bit (S) PAL:
 1 = (R-Y) line normal
 0 = (R-Y) line inverted

NTSC: 1 = no change

2.5 Output Formatter

The output formatter sets how the data is formatted for output on the TVP5160 output buses. Table 2-2 shows the available output modes.

Table 2-2. Output Format

TERMINAL NAME	TERMINAL NUMBER	ITU-R BT.656 10-Bit 4:2:2 YCbCr	20-BIT 4:2:2 YCbCr
Y_9	87	Cb9, Y9, Cr9	Y9
Y_8	88	Cb8, Y8, Cr8	Y8
Y_7	89	Cb7, Y7, Cr7	Y7
Y_6	90	Cb6, Y6, Cr6	Y6
Y_5	91	Cb5, Y5, Cr5	Y5
Y_4	94	Cb4, Y4, Cr4	Y4
Y_3	95	Cb3, Y3, Cr3	Y3
Y_2	96	Cb2, Y2, Cr2	Y2
Y_1	97	Cb1, Y1, Cr1	Y1
Y_0	98	Cb0, Y0, Cr0	Y0
C_9	101		Cb9, Cr9
C_8	102		Cb8, Cr8
C_7	103		Cb7, Cr7
C_6	104		Cb6, Cr6
C_5	107		Cb5, Cr5
C_4	108		Cb4, Cr4
C_3	109		Cb3, Cr3
C_2	110		Cb2, Cr2
C_1	113		Cb1, Cr1
C_0	114		Cb0, Cr0

Table 2-3. Summary of Line Frequency, Data Rate, and Pixel/Line Counts

STANDARDS	PIXELS PER LINE	ACTIVE PIXELS PER LINE	LINES PER FRAME	PIXEL FREQ (MHz)	COLOR SUBCARRIER FREQUENCY (MHz)	HORIZONTAL LINE RATE (kHz)
ITU-R BT.601 sampling						
NTSC-J, M	858	720	525	13.5	3.579545	15.73426
NTSC-4.43	858	720	525	13.5	4.43361875	15.73426
PAL-M	858	720	525	13.5	3.57561149	15.73426
PAL-60	858	720	525	13.5	4.43361875	15.73426
PAL-B, D, G, H, I	864	720	625	13.5	4.43361875	15.625
PAL-N	864	720	625	13.5	4.43361875	15.625
PAL-Nc	864	720	625	13.5	3.58205625	15.625
SECAM	864	720	625	13.5	Dr = 4.406250 Db = 4.250000	15.625

The TVP5160 input-to-output processing delay depends on the operating mode and the video standard. When 3DYC is enabled, the processing delay is approximately 1 frame and 2-1/3 lines. When 3DYC is disabled, the processing delay is approximately 2-1/3 lines.

2.6 Fast Switches for SCART and Digital Overlay

The TVP5160 decoder supports the SCART interface used mainly in European audio/video end equipment to carry mono/stereo audio, composite video, S-Video, and RGB video on the same cable. In the event that composite video and RGB video are present simultaneously on the video pins assigned to a SCART interface, the TVP5160 decoder assumes they are pixel synchronous to each other. The timing for both composite video and RGB video is obtained from the composite source and its derived clock is used to sample RGB video as well. The fast-switch input pin allows switching between these two input video sources on a pixel-by-pixel basis. This feature can be used to, for example, overlay RGB graphics for on-screen display onto decoded CVBS video. The SCART overlay control signals (FSS) are oversampled at 4× the pixel clock frequency. The phase of this signal is used to mix between the CVBS input and the analog RGB inputs. This improves the analog overlay picture quality when the external FSS and analog video signals are generated by an asynchronous source. The TVP5160 decoder has two programmable delays for component video to compensate for composite comb filter delays and two programmable delays for digital RGB to compensate AFE and decimation filter delays.

If the overlay output is digital supporting 8 colors of data, the TVP5160 decoder can take digital overlay inputs using terminals C6, C7, and C8. For this mode, output must be the 10-bit ITU-R BT.656 mode. [Figure 2-6](#) shows the block diagram of two fast-switches. [Table 2-4](#) shows the fast-switch 1 and 2 controls.

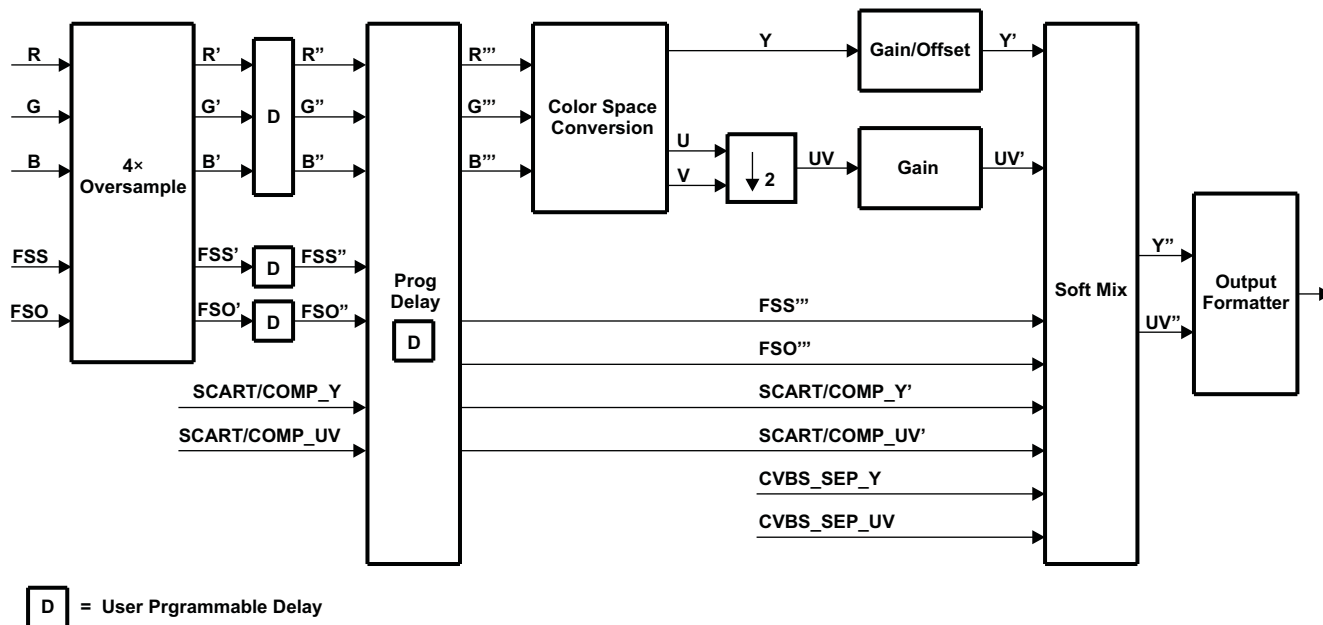

Figure 2-6. Fast-Switches for SCART and Digital Overlay

Table 2-4. Fast-Switch Modes

MODES	DESCRIPTION
000	CVBS ↔ SCART
001	CVBS, S_Video ↔ Digital overlay
010	Component ↔ Digital overlay
011	(CVBS ↔ SCART) ↔ Digital overlay
100	(CVBS ↔ Digital overlay) ↔ SCART
101	CVBS ↔ (SCART ↔ Digital overlay)
110	Composite
111	No switching

Fast switching of digital RGB input: closed caption decoder output is digital RGB with blanking signal. The TVP5160 decoder supports this digital RGB input and can do overlay with composite, S-Video, or component video.

See TI application note [SLEA016](#), *TVP5146 SCART and OSD*, for more information on SCART overlay and digital overlay programming.

Table 2-5. Look-Up Table for Converting from Digital RGB to 10-Bit YCbCr Data

COLOR	INPUT			OUTPUT		
	DR	DG	DB	Y	Cb	Cr
BLACK	0	0	0	64	512	512
BLUE	0	0	1	164	960	440
GREEN	0	1	0	580	216	136
CYAN	0	1	1	680	664	64
RED	1	0	0	324	360	960
MAGENTA	1	0	1	424	808	888
YELLOW	1	1	0	840	64	584
WHITE	1	1	1	940	512	512

2.7 Discrete Syncs

VS, HS, and VBLK are independently software programmable to a 1× pixel count. This allows any possible alignment to the internal pixel count and line count. The default settings for a 525-line and 625-line video output are given as an example below. FID changes at the same transient time when the trailing edge of vertical sync occurs. The polarity of FID is programmable by an I²C interface.

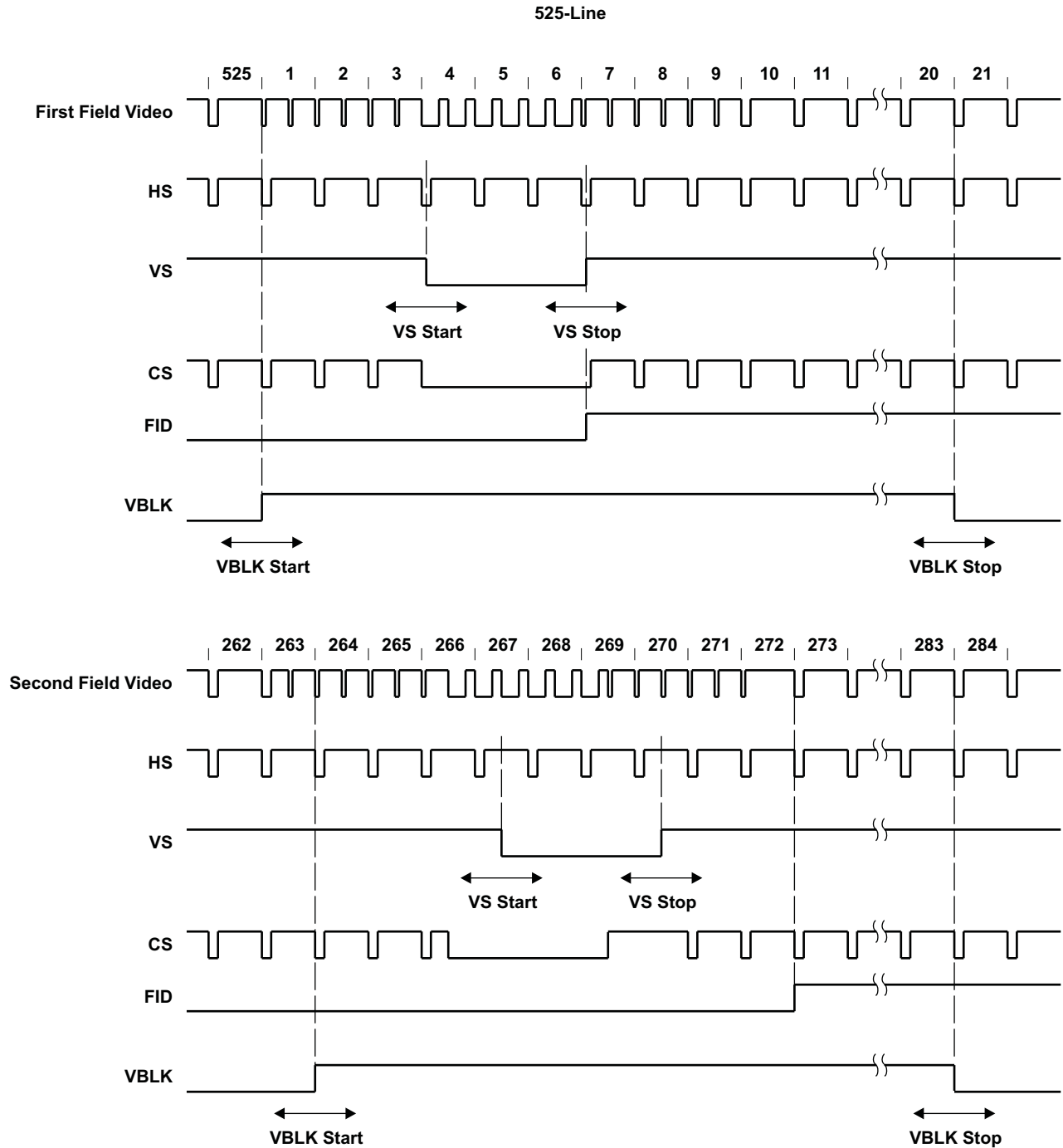

NOTE: Line numbering conforms to ITU-R BT.470.

Figure 2-7. Vertical Synchronization Signals for 525-Line System

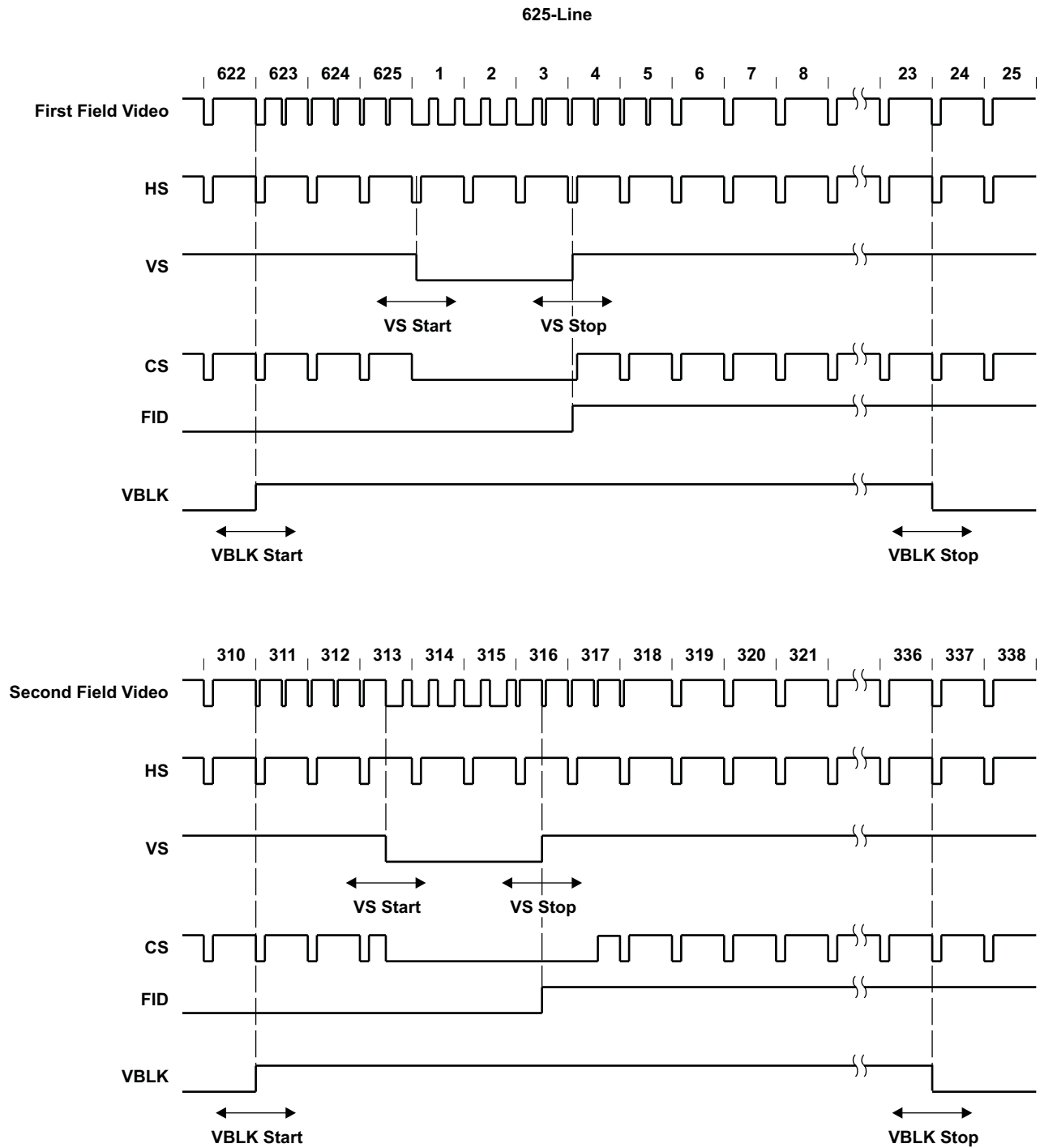

A. NOTE: Line numbering conforms to ITU-R BT.470.

Figure 2-8. Vertical Synchronization Signals for 625-Line System

ITU-R BT.656 10-bit 4:2:2 Timing with 2× pixel clock reference

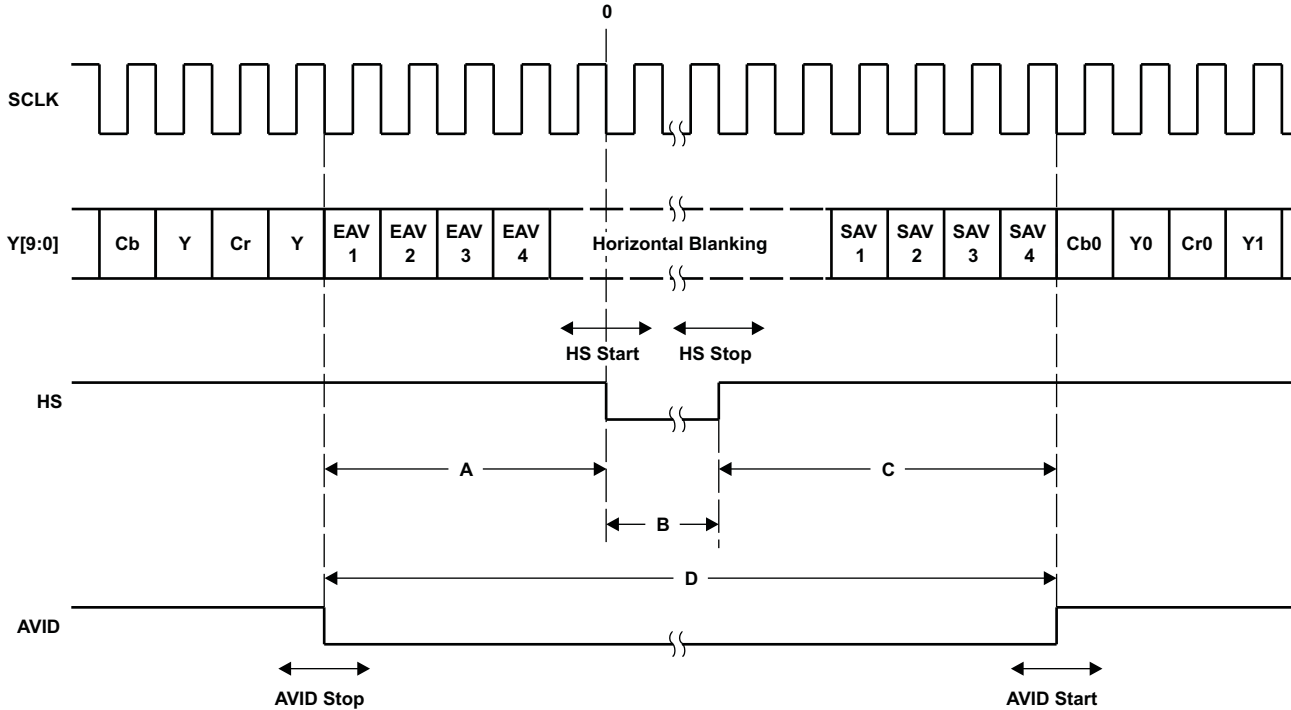
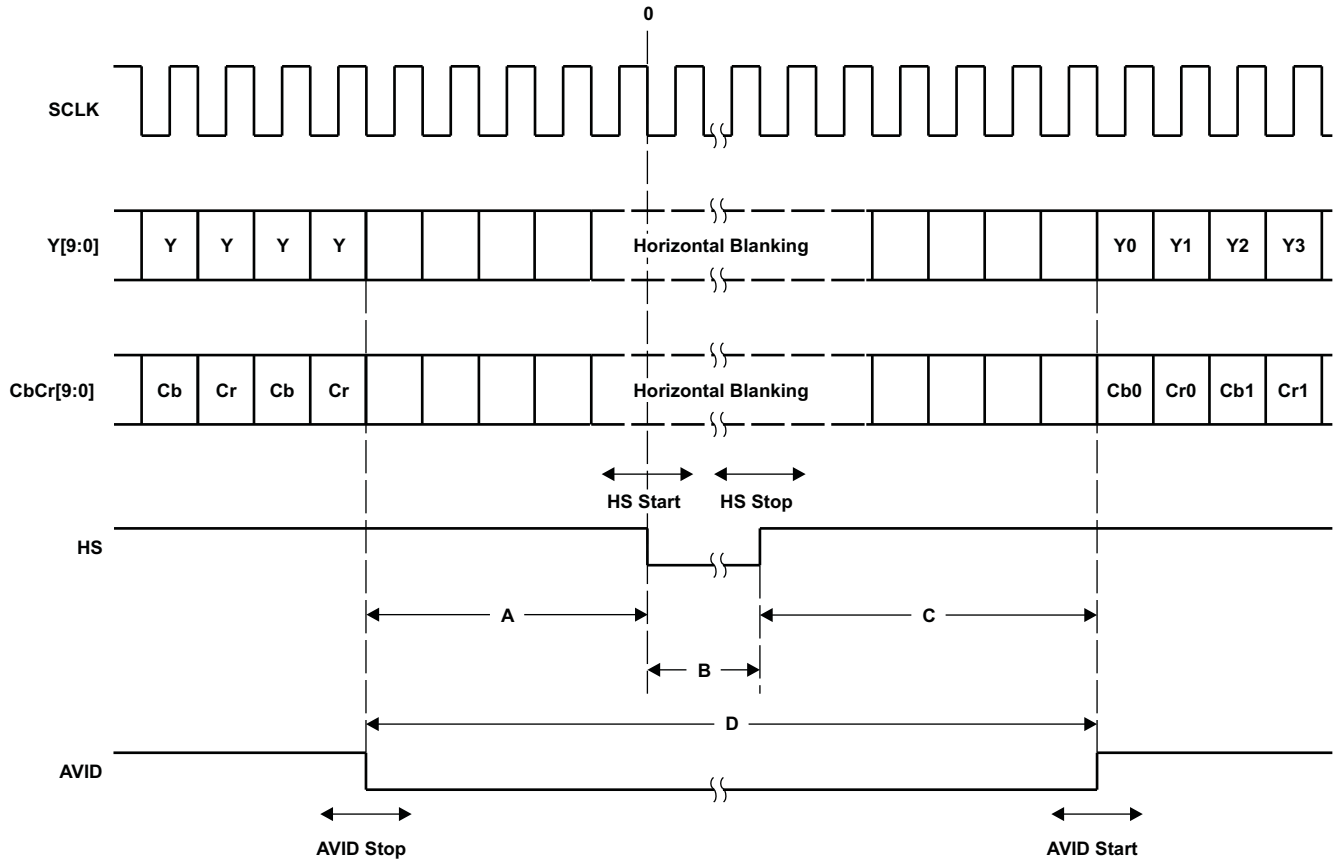

Figure 2-9. Horizontal Synchronization Signals for 10-Bit 4:2:2 Mode

SCLK = 2 × PIXEL CLOCK ⁽¹⁾				
MODE	A	B	C	D
NTSC 601	106	128	42	276
PAL 601	112	128	48	288
480p	106	128	42	276
576p	112	128	48	288

(1) ITU-R BT.656 10-bit 4:2:2 timing with 2× pixel clock reference 601 = ITU-R BT.601 timing



NOTE: AVID rising edge occurs 4 clock cycles early.

NOTE: AVID rising edge occurs 4 clock cycles early.

Figure 2-10. Horizontal Synchronization Signals for 20-Bit 4:2:2 Mode

SCLK = 1X PIXEL CLOCK ⁽¹⁾				
MODE	A	B	C	D
NTSC 601	53	64	19	138
PAL 601	56	64	22	144
480p	53	64	19	138
576p	56	64	22	144

(1) 20-bit 4:2:2 timing with 1× pixel clock reference 601 = ITU-R BT.601 timing

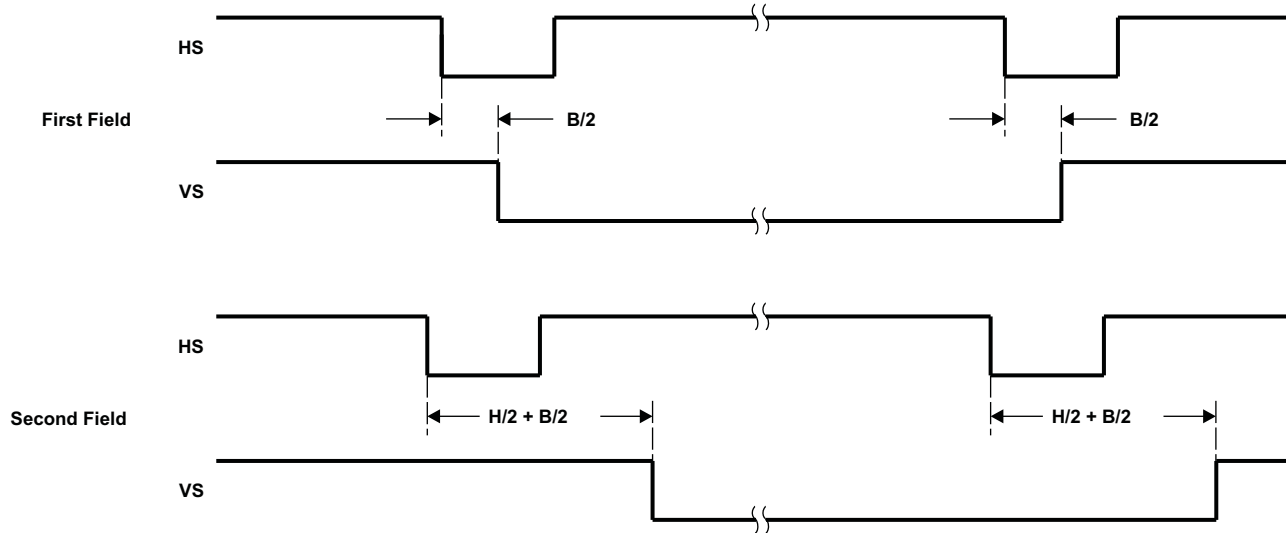

Figure 2-11. VS Position With Respect to HS for Interlaced Signals

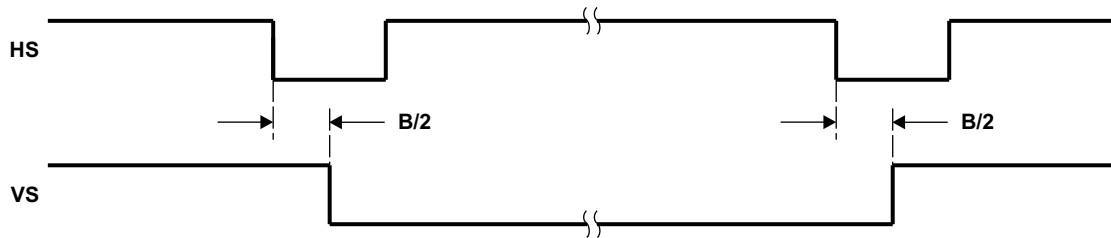

Figure 2-12. VS Position With Respect to HS for Progressive Signals

MODE ⁽¹⁾	10-BIT (SCLK = 2 × PIXEL CLOCK)		20-BIT (SCLK = 1 × PIXEL CLOCK)	
	B/2	H/2	B/2	H/2
NTSC 601 interlaced	64	858	32	429
PAL 601 interlaced	64	864	32	432
NTSC 601 progressive		858	32	
PAL 601 progressive		864	32	

(1) 601 = ITU-R BT.601 timing

2.8 Embedded Syncs

Standard with embedded syncs insert SAV and EAV codes into the data stream on the rising and falling edges of AVID. These codes contain the V and F bits which also define vertical timing. Table 2-6 shows the format of the SAV and EAV codes.

H equals 1b always indicates EAV. H equals 0b always indicates SAV. The alignment of V and F to the line and field counter varies depending on the standard.

The P bits are protection bits:

- P3 = V xor H
- P2 = F xor H
- P1 = F xor V
- P0 = F xor V xor H

Table 2-6. EAV and SAV Sequence

	Y9 (MSB)	Y8	Y7	Y6	Y5	Y4	Y3	Y2	Y1	Y0
Preamble	1	1	1	1	1	1	1	1	1	1
Preamble	0	0	0	0	0	0	0	0	0	0
Preamble	0	0	0	0	0	0	0	0	0	0
Status	1	F	V	H	P3	P2	P1	P0	0	0

2.9 I²C Host Interface

Communication with the TVP5160 decoder is via an I²C host interface. The I²C standard consists of two signals, the serial input/output data (SDA) line and input/output clock line (SCL), which carry information between the devices connected to the bus. A 2-bit control signal (I2CA0/ I2CA1) selects the slave address. Although an I²C system can be multi-mastered, the TVP5160 decoder can function as a slave device only. Because SDA and SCL are kept open-drain at logic high output level or when the bus is not driven, the user must connect SDA and SCL to IOVDD via a pullup resistor on the board. The slave address select, terminals 83 and 82 (I2CA0 and I2CA1), enables the use of four TVP5160 devices tied to the same I²C bus, because it controls the two least significant bits of the I²C device address.

Table 2-7. I²C Host Interface Terminal Description

SIGNAL	TYPE	DESCRIPTION
I2CA0	I	Slave address selection
I2CA1	I	Slave address selection
SCL	I/O	Input clock line
SDA	I/O	Input/output data line

2.9.1 Reset and I²C Bus Address Selection

The TVP5160 decoder can respond to four possible chip addresses. The address selection is made at reset by an externally supplied level on the I2CA0/I2CA1 pins. The TVP5160 decoder samples the level of terminals 83 and 82 at power up or at the trailing edge of RESETB and configures the I²C bus address bit A0/A1.

Table 2-8. I²C Host Interface Device Addresses

A6	A5	A4	A3	A2	A1(I2CA1) ⁽¹⁾	A0 (I2CA0) ⁽¹⁾	R/W	HEX
1	0	1	1	1	0 (default)	0 (default)	1/0	B9/B8
1	0	1	1	1	0	1	1/0	BB/BA
1	0	1	1	1	1	0	1/0	BD/BC
1	0	1	1	1	1	1	1/0	BF/BE

(1) To pull up the I²C terminals high, tie to IOVDD via a 2.2-kΩ resistor.

2.9.2 I²C Operation

Data transfers occur utilizing the following formats.

Read from I²C control registers

S	10111000	ACK	subaddress	ACK	S	10111001	ACK	receive data	NAK	P
---	----------	-----	------------	-----	---	----------	-----	--------------	-----	---

Write to I²C control registers

S	10111000	ACK	subaddress	ACK	send data	ACK	P
---	----------	-----	------------	-----	-----------	-----	---

S = I²C bus start condition

P = I²C bus stop condition

ACK = Acknowledge generated by the slave

NAK = Acknowledge generated by the master, for multiple byte read master will ACK each byte except the last byte

Subaddress = Subaddress byte

Data = Data byte

I²C bus address = In the example shown, I2CA0/I2CA1 are in default mode. Write (B8h), Read (B9h)

2.9.3 VBUS Access

The TVP5160 decoder has additional internal registers accessible through an indirect access to an internal 24-bit address wide VBUS. Figure 2-13 shows the VBUS registers access.

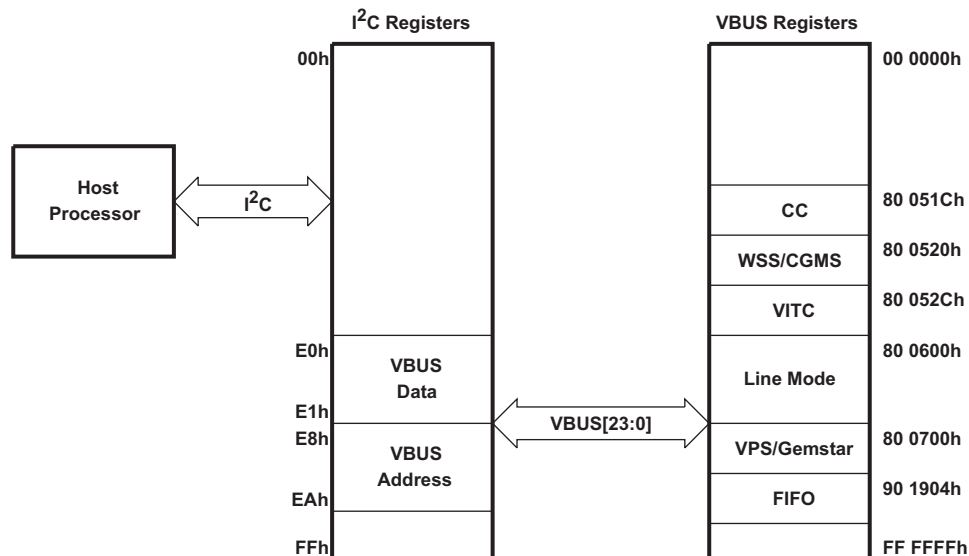

Figure 2-13. VBUS Access

2.9.3.1 VBUS Write

Single byte

S	B8	ACK	E8	ACK	VA0	ACK	VA1	ACK	VA2	ACK	P
S	B8	ACK	E0	ACK	send data	ACK					P

Multiple bytes

S	B8	ACK	E8	ACK	VA0	ACK	VA1	ACK	VA2	ACK	P
S	B8	ACK	E1	ACK	send data	ACK	...	send data	ACK		P

2.9.3.2 VBUS Read

Single byte

S	B8	ACK	E8	ACK	VA0	ACK	VA1	ACK	VA2	ACK	P
S	B8	ACK	E0	ACK	S	B9	ACK	read data	NAK		P

Multiple bytes

S	B8	ACK	E8	ACK	VA0	ACK	VA1	ACK	VA2	ACK	P		
S	B8	ACK	E1	ACK	S	B9	ACK	read data	MACK	...	read data	NAK	P

NOTE: Examples use default I²C address

ACK = Acknowledge generated by the slave

MACK = Acknowledge generated by the master

NAK = No Acknowledge generated by the master

2.10 VBI Data Processor

The TVP5160 VBI data processor (VDP) slices various data services like teletext (WST, NABTS), closed caption (CC), wide screen signaling (WSS), program delivery control (PDC), vertical interval time code (VITC), video program system (VPS), copy generation management system (CGMS) data, and electronic program guide (EPG or Gemstar) 1x/2x. [Table 2-9](#) shows the supported VBI system.

These services are acquired by programming the VDP to enable the reception of one or more VBI data standard(s) in the vertical blanking interval. The VDP can be programmed on a line-per-line basis to enable simultaneous reception of different VBI formats, one per line. The results are stored in a FIFO and/or registers. Because of its high data bandwidth, the teletext results are stored in the FIFO only. The TVP5160 decoder provides fully decoded V-Chip data to the dedicated registers at subaddresses 800540h through 800543h.

Table 2-9. Supported VBI System

VBI SYSTEM	STANDARD	LINE NUMBER	NUMBER OF BYTES
Teletext WST A	SECAM	6–23 (Field 1, 2)	38
Teletext WST B	PAL	6–22 (Field 1, 2)	43
Teletext NABTS C	NTSC	10–21 (Field 1, 2)	34
Teletext NABTS D	NTSC-J	10–21 (Field 1, 2)	35
Closed Caption	PAL	22 (Field 1, 2)	2
Closed Caption	NTSC	21 (Field 1, 2)	2
WSS-CGMS	PAL	23 (Field 1, 2)	14 bits
WSS-CGMS	NTSC	20 (Field 1, 2)	20 bits
VITC	PAL	6–22	9
VITC	NTSC	10–20	9
VPS	PAL	16	13
V-Chip (Decoded)	NTSC	21 (Field 2)	2

Table 2-9. Supported VBI System (continued)

VBI SYSTEM	STANDARD	LINE NUMBER	NUMBER OF BYTES
Gemstar EPG 1×	NTSC		2
Gemstar EPG 2×	NTSC		5 with frame byte
User	Any	Programmable	Programmable
CGMS-A packet A	480p	41	20 bits
CGMS-A packet B	480p	40	16 bytes

2.10.1 VBI FIFO and Ancillary Data in Video Stream

Sliced VBI data can be output as ancillary data in the video stream in ITU-R BT.656 mode. VBI data is output on the Y[9:2] terminals during the horizontal blanking period following the line from which the data was retrieved. Table 2-10 shows the header format and sequence of the ancillary data inserted into the video stream. This format also stores any VBI data into the FIFO. The size of the FIFO is 512 bytes. Therefore, the FIFO can store up to 9 lines of teletext data according to the WSTB standard.

Table 2-10. Ancillary Data Format and Sequence

BYTE NO.	Y7(MSB)	Y6	Y5	Y4	Y3	Y2	Y1	Y0 (LSB)	DESCRIPTION	
0	0	0	0	0	0	0	0	0	Ancillary data preamble	
1	1	1	1	1	1	1	1	1		
2	1	1	1	1	1	1	1	1		
3	NEP	EP	0	1	0	DID2	DID1	DID0	Data ID (DID)	
4	NEP	EP	F5	F4	F3	F2	F1	F0	Secondary data ID (SDID)	
5	NEP	EP	N5	N4	N3	N2	N1	N0	Number of 32 bit data (NN)	
6	Video line # [7:0]								Internal Data ID0 (IDID0)	
7	0	0	0	Data error	Match #1	Match #2	Video line # [9:8]		Internal Data ID1 (IDID1)	
8	Sample 1								Data byte	1st word
9	Sample 2								Data byte	
10	Sample 3								Data byte	
11	Sample 4								Data byte	
.	.								.	
.	.								.	
	Sample m-1								Data byte	N th word
4N+5	Sample m								Data byte	
4N+6	CS[7:0]								Checksum	
4N+7	0	0	0	0	0	0	0	0	Fill byte	

EP: Even parity for Y5–Y0

NEP: Negated even parity

DID: 91h: Sliced data of VBI lines of first field
53h: Sliced data of line 24 to end of first field
55h: Sliced data of VBI lines of second field
97h: Sliced data of line 24 to end of second field

SDID: This field holds the data format taken from the line mode register bits [5:0] of the corresponding line.

NN: Number of Dwords beginning with byte 8 through 4N+7. Note this value is the number of Dwords where each Dword is 4 bytes.

IDID0: Transaction video line number [7:0]

- IDID1: Bit 0/1 – Transaction video line number [9:8]
 Bit 2 – Match 2 flag
 Bit 3 – Match 1 flag
 Bit 4 – 1b if at least one error was detected in the EDC block. 0b if no error was detected.
- CS: Sum of Y7–Y0 of byte 8 through byte 4N+5. For teletext modes, byte 8 is the sync pattern byte. Byte 9 is Sample 1.
- Fill byte: Fill byte makes a multiple of 4 bytes from byte zero to last fill byte

2.10.2 VBI Raw Data Out

The TVP5160 decoder can output raw A/D video data at twice the sampling rate for external VBI slicing. This is transmitted as an ancillary data block, although a bit differently from the way the sliced VBI data is transmitted in the FIFO format as described in Section 3.10.1. The samples are transmitted during the active portion of the line. VBI raw data uses ITU-R BT 656 format having only luma data. The chroma samples are replaced by luma samples. The TVP5160 decoder inserts a 4-byte preamble 000h 3FFh 3FFh 180h before data start. There is no checksum byte or fill bytes in this mode.

DATA NO.	Y9 (MSB)	Y8	Y7	Y6	Y5	Y4	Y3	Y2	Y1	Y0 (LSB)	DESCRIPTION
0	0	0	0	0	0	0	0	0	0	0	VBI raw data preamble
1	1	1	1	1	1	1	1	1	1	1	
2	1	1	1	1	1	1	1	1	1	1	
3	0	1	1	0	0	0	0	0	0	0	
4	Sample 1										2× pixel rate Luma data (i.e., NTSC 601: n = 1707)
5	Sample 2										
⋮	⋮										
n-1	Sample n-5										
N	Sample n-4										

2.11 Powerup, Reset, and Initialization

No specific power-up sequence is required, but all power supplies must be active and stable within 500 ms of each other. Reset may be low during power-up, but must remain low for at least 1 μs after the power supplies become stable and the crystal begins to oscillate. Alternately, reset may be asserted any time after power up and a stable crystal oscillation, and must remain asserted for at least 1 μs. [Table 2-11](#) describes the status of the TVP5160 terminals during and immediately after reset.

200 μs must be allowed after reset before commencing I²C operations if the SCL pin is not monitored during I²C operations

Table 2-11. Reset Sequence

SIGNAL NAME	DURING RESET	RESET COMPLETED
Y[9:0], SCLK	Input	High-impedance
C[9:0]/GPIO	Input	Input
RESETB, PWDN, SDA, SCL, FSS/GPIO, AVID/GPIO, GLCO/GPIO/I2CA0, HS/CS/GPIO, VS/VBLK/GPIO, FID/GPIO	Input	Input
INTREQ	Input	Output (open drain)

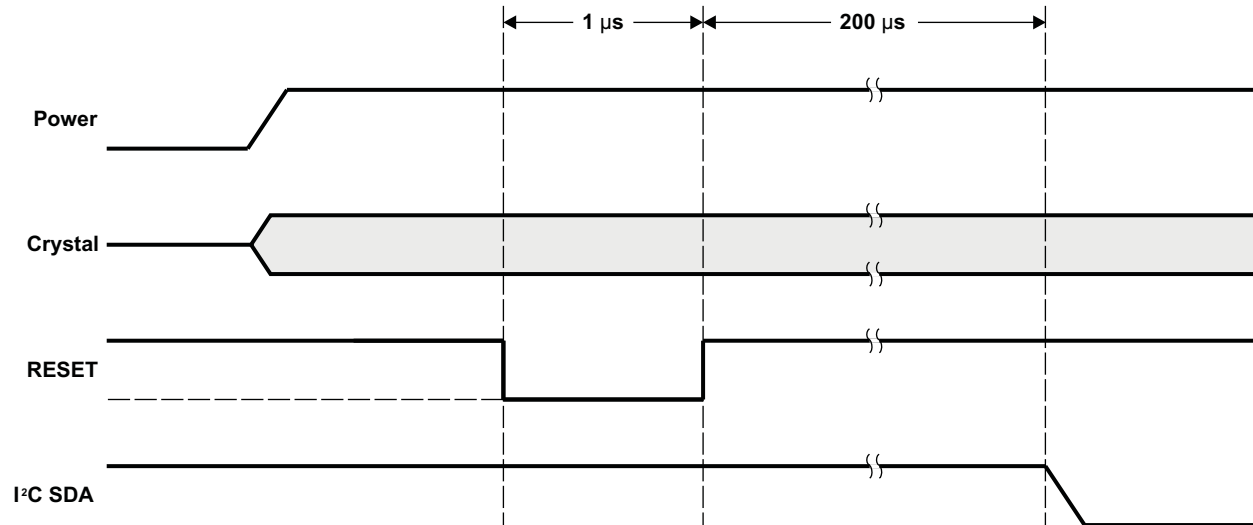

Figure 2-14. Reset Timing

After reset has completed, the following sequence of operations must be completed:

1. Write 01h to VBus register 0xB00060
2. Write 01h to VBus register 0xB00063
3. Write 00h to VBus register 0xB00060

2.12 Adjusting External Syncs

The TVP5160 decoder stores values for the positions of the external syncs for two different modes:

- 525-line with ITU-R BT.601 sampling
- 625-line with ITU-R BT.601 sampling

Once the values are stored, they are retained and restored when the signal switches back into one of these two modes.

The proper sequence to change the external sync positions is:

- To set NTSC, PAL-M, NTSC 443, PAL 60 (525-line modes):
 - Make sure the standard is one of the above 525-line mode formats by forcing the video standard
 - Set HS, VS, VBLK, and AVID external syncs (register 16h through 24h)
- To set PAL, PAL-N, SECAM (625-line modes):
 - Make sure the standard is one of the above 625-line mode formats by forcing the video standard
 - Set HS, VS, VBLK, and AVID external syncs (register 16h through 24h)

Once programmed, the values for each mode are retained when the signal switches back into that or other compatible video standards.

3 Internal Control Registers

The TVP5160 decoder is initialized and controlled by a set of internal registers that define the operating parameters of the entire device. Communication between the external controller and the TVP5160 decoder is through a standard I²C host port interface, as described earlier.

Table 3-1 shows the summary of these registers. Detailed programming information for each register is described in the following sections. Additional registers are accessible through an indirect procedure involving access to an internal 24-bit address wide VBUS. Table 3-2 shows the summary of VBUS registers.

Table 3-1. I²C Registers Summary

REGISTER NAME	I ² C SUBADDRESS	DEFAULT	R/W ⁽¹⁾
Input/Output Select	00h	00h	R/W
AFE Gain Control	01h	0Fh	R/W
Video Standard Select	02h	00h	R/W
Operation Mode	03h	00h	R/W
Autoswitch Mask	04h	23h	R/W
Color Killer	05h	10h	R/W
Luminance Processing Control 1	06h	00h	R/W
Luminance Processing Control 2	07h	00h	R/W
Luminance Processing Control 3	08h	00h	R/W
Luminance Brightness	09h	80h	R/W
Luminance Contrast	0Ah	80h	R/W
Chrominance Saturation	0Bh	80h	R/W
Chroma Hue	0Ch	00h	R/W
Chrominance Processing Control 1	0Dh	00h	R/W
Chrominance Processing Control 2	0Eh	0Ch	R/W
Reserved ⁽²⁾	0Fh		
Pr Contrast	10h	80h	R/W
Y Contrast	11h	80h	R/W
Pb Contrast	12h	80h	R/W
Reserved ⁽²⁾	13h		
G/Y Brightness	14h	80h	R/W
Reserved ⁽²⁾	15h		
AVID Start Pixel	16h–17h	55h/5Fh	R/W
AVID Stop Pixel	18h–19h	325h/32Fh	R/W
HS Start Pixel	1Ah–1Bh	00h/07h	R/W
HS Stop Pixel	1Ch–1Dh	40h/47h	R/W
VS Start Line	1Eh–1Fh	004h/001h	R/W
VS Stop Line	20h–21h	007h/004h	R/W
VBLK Start Line	22h–23h	001h/26Fh	R/W
VBLK Stop Line	24h–25h	015h/018h	R/W
Embedded Sync Offset Control 1	26h	00h	R/W
Embedded Sync Offset Control 2	27h	00h	R/W
Fast Switch Control	28h	C0h	R/W
Fast Switch Overlay Delay	29h	17h	R/W
Fast Switch SCART Delay	2Ah	1Ch	R/W
Overlay Delay	2Bh	12h	R/W

(1) R = Read only, W = Write only, R/W = Read and write

(2) Reserved I²C register addresses must not be written to.

Table 3-1. I²C Registers Summary (continued)

REGISTER NAME	I ² C SUBADDRESS	DEFAULT	R/W ⁽¹⁾
SCART Delay	2Ch	56h	R/W
Reserved ⁽²⁾	2Dh		
CTI Control	2Eh	00h	R/W
Brightness and Contrast Range Extender	2Fh	00h	R/W
Component Autoswitch Mask	30h	00h	R/W
Reserved ⁽²⁾	31h		
Sync Control	32h	00h	R/W
Output Formatter 1	33h	40h	R/W
Output Formatter 2	34h	00h	R/W
Output Formatter 3	35h	FFh	R/W
Output Formatter 4	36h	FFh	R/W
Output Formatter 5	37h	FFh	R/W
Output Formatter 6	38h	FFh	R/W
Clear Lost Lock Detect	39h	00h	R/W
Status 1	3Ah		R
Status 2	3Bh		R
AGC Gain Status	3Ch–3Dh		R
Reserved ⁽²⁾	3Eh		
Video Standard Status	3Fh		R
GPIO Input 1	40h		R
GPIO Input 2	41h		R
Reserved ⁽²⁾	42h–43h		
Back End AGC Status	44h		R
Reserved ⁽²⁾	45h		
AFE Coarse Gain for CH1	46h	20h	R/W
AFE Coarse Gain for CH2	47h	20h	R/W
AFE Coarse Gain for CH3	48h	20h	R/W
AFE Coarse Gain for CH4	49h	20h	R/W
AFE Fine Gain for Pb	4Ah–4Bh	900h	R/W
AFE Fine Gain for Chroma	4Ch–4Dh	900h	R/W
AFE Fine Gain for Pr	4Eh–4Fh	900h	R/W
AFE Fine Gain for CVBS_Luma	50h–51h	900h	R/W
Reserved ⁽²⁾	52h–56h		
656 Version	57h	00h	R/W
Reserved ⁽²⁾	58h		
SDRAM Control	59h	00h	R/W
Y Noise Sensitivity	5Ah	80h	R/W
UV Noise Sensitivity	5Bh	80h	R/W
Y coring threshold	5Ch	80h	R/W
UV coring threshold	5Dh	40h	R/W
Low Noise Limit	5Eh	40h	R/W
"Blue" Screen Y	5Fh	00h	R/W
"Blue" Screen Cb	60h	80h	R/W
"Blue" Screen Cr	61h	80h	R/W
"Blue" Screen LSB	62h	00h	R/W
3DNR Noise Measurement LSB	64h		R
3DNR Noise Measurement MSB	65h		R

Table 3-1. I²C Registers Summary (continued)

REGISTER NAME	I ² C SUBADDRESS	DEFAULT	R/W ⁽¹⁾
Y Core0 (3DNR)	66h		R
UV Core0 (3DNR)	67h		R
Reserved ⁽²⁾	68h		
F and V Bit Decode Control	69h	00h	R/W
Reserved ⁽²⁾	6Ah-6Bh		
Back End AGC Control	6Ch	08h	R/W
Reserved ⁽²⁾	6Eh		
AGC Decrement Speed	6Fh	04h	R/W
ROM Version	70h		R
RAM Version MSB	71h		R
Reserved ⁽²⁾	72h-73h		
AGC White Peak Processing	74h	00h	R/W
F and V Bit Control	75h	16h	R/W
Reserved ⁽²⁾	76h-77h		
AGC Increment Speed	78h	06h	R/W
AGC Increment Delay	79h	1Eh	R/W
Analog Output Control 1	7Fh	00h	R/W
CHIP ID MSB	80h	51h	R
CHIP ID LSB	81h	60h	R
RAM Version MSB	82h		R
Color PLL Speed Control	83h	09h	R/W
3DYC Luma Coring LSB	84h	20h/20h	R/W
3DYC Chroma Coring LSB	85h	20h/2Ah	R/W
3DYC Chroma/Luma MSBs	86h	00h/00h	R/W
3DYC Luma Gain	87h	08h/08h	R/W
3DYC Chroma Gain	88h	08h/08h	R/W
3DYC Signal Quality Gain	89h	02h/02h	R/W
3DYC Signal Quality Coring	8Ah-8Bh	328h/380h	R/W
IF Compensation Control	8Dh	00h	R/W
IF Differential Gain Control	8Eh	22h	R/W
IF Low Frequency Gain Control	8Fh	44h	R/W
IF High Frequency Gain Control	90h	00h	R/W
Reserved ⁽²⁾	91h-94h		
Weak Signal High Threshold	95h	60h	R/W
Weak Signal Low Threshold	96h	50h	R/W
Status Request	97h	00h	R/W
3DYC NTSC VCR Threshold	98h	10h	R/W
3DYC PAL VCR Threshold	99h	20h	R/W
Vertical Line Count	9Ah-9Bh	00h	R
Reserved ⁽²⁾	9Ch-9Dh		
AGC Decrement Delay	9Eh		R/W
Reserved ⁽²⁾	9Fh-B0h		
VDP TTX Filter 1 Mask 1	B1h	00h	R/W
VDP TTX Filter 1 Mask 2	B2h	00h	R/W
VDP TTX Filter 1 Mask 3	B3h	00h	R/W
VDP TTX Filter 1 Mask 4	B4h	00h	R/W
VDP TTX Filter 1 Mask 5	B5h	00h	R/W

Table 3-1. I²C Registers Summary (continued)

REGISTER NAME	I ² C SUBADDRESS	DEFAULT	R/W ⁽¹⁾
VDP TTX Filter 2 Mask 1	B6h	00h	R/W
VDP TTX Filter 2 Mask 2	B7h	00h	R/W
VDP TTX Filter 2 Mask 3	B8h	00h	R/W
VDP TTX Filter 2 Mask 4	B9h	00h	R/W W
VDP TTX Filter 2 Mask 5	BAh	00h	R/W
VDP TTX Filter Control	BBh	00h	R/W
VDP FIFO Word Count	BCh		R
VDP FIFO Interrupt Threshold	BDh	80h	R/W
Reserved	BEh		
VDP FIFO Reset	BFh	00h	R/W
VDP FIFO Output Control	C0h	00h	R/W
VDP Line Number Interrupt	C1h	00h	R/W
VDP Pixel Alignment	C2h–C3h	01Eh	R/W
Reserved	C4h–D5h		
VDP Line Start	D6h	06h	R/W
VDP Line Stop	D7h	1Bh	R/W
VDP Global Line Mode	D8h	FFh	R/W
VDP Full Field Enable	D9h	00h	R/W
VDP Full Field Mode	DAh	FFh	R/W
Interlaced/Progressive Status	DBh		R
Reserved ⁽²⁾	DCh–DFh		
VBUS Data Access with No VBUS Address Increment	E0h		R/W
VBUS Data Access with VBUS Address Increment	E1h		R/W
VDP FIFO Read Data	E2h		R
Reserved ⁽²⁾	E3h–E7h		
VBUS Address Access	E8h–EAh	00 0000h	R/W
Reserved ⁽²⁾	EBh–EFh		
Interrupt Raw Status 0	F0h		R
Interrupt Raw Status 1	F1h		R
Interrupt Status 0	F2h		R
Interrupt Status 1	F3h		R
Interrupt Mask 0	F4h	00h	R/W
Interrupt Mask 1	F5h	00h	R/W
Interrupt Clear 0	F6h	00h	R/W
Interrupt Clear 1	F7h	00h	R/W
Reserved ⁽²⁾	F8h–FFh		

Table 3-2. VBUS Registers Summary

REGISTER NAME	VBUS SUBADDRESS	DEFAULT	R/W ⁽¹⁾
Reserved ⁽²⁾⁽³⁾	00 0000h – 80 051Bh		
VDP Closed Caption Data	80 051Ch – 80 051Fh		R
VDP WSS/CGMS data	80 0520h – 80 0526h		R
Reserved ⁽²⁾⁽³⁾	80 0527h – 80 052Bh		
VDP VITC Data	80 052Ch – 80 0534h		R
Reserved ⁽²⁾⁽³⁾	80 0535h – 80 053Fh		
VDP V-Chip Data	80 0540h – 80 0543h		R
Reserved ⁽²⁾⁽³⁾	80 0544h – 80 05FFh		
VDP General Line Mode and Address	80 0600h – 80 0611h	FFh, 00h	R/W
Reserved ⁽²⁾⁽³⁾	80 0612h – 80 06FFh		
VDP VPS/Gemstar EPG Data	80 0700h – 80 070Ch		R
Reserved ⁽²⁾⁽³⁾	80 070Dh – A0 005Dh		
Analog Output Control 2	A0 005Eh	B2h	R/W
Reserved ⁽²⁾⁽³⁾	A0 005Fh – B0 005Fh		
Interrupt Configuration Register	B0 0060h	00h	R/W
Reserved ⁽²⁾⁽³⁾	B0 0062h – B0 0064h		
Interrupt Mask 1	B0 0065h		R
Interrupt Raw Status 1	B0 0069h		R
Interrupt Status 1	B0 006Dh		R
Interrupt Clear 1	B0 0071h		R
Reserved ⁽²⁾⁽³⁾	B0 0073h – FF FFFFh		

(1) R = Read only, W = Write only, R/W = Read and write

(2) Register addresses not shown in the register map summary are reserved and must not be written to.

(3) Writing to or reading from any value labeled "Reserved" register may cause erroneous operation of the TVP5160 decoder. For registers with reserved bits, a 0b must be written to reserved bit locations unless otherwise stated.

3.1 Register Definitions

Table 3-3. Input/Output Select

Subaddress	00h
Default	00h

7	6	5	4	3	2	1	0
Input select [7:0]							

Twelve input terminals can be configured to support composite, S-Video, and component YPbPr. Only values in Table 3-4 are valid.

NOTE: The video output can be either CVBS, Y, or G.

Table 3-4. Analog Channel and Video Mode Selection

MODE	INPUT(S) SELECTED	INPUT SELECT [7:0]									OUTPUT
		7	6	5	4	3	2	1	0	HEX	
CVBS	VI_1 (default)	0	0	0	0	0	0	0	0	00	VI_1
	VI_2	0	0	0	0	0	0	0	1	01	VI_2
	VI_3	0	0	0	0	0	0	1	0	02	VI_3
	VI_4	0	0	0	0	0	1	0	0	04	VI_4
	VI_5	0	0	0	0	0	1	0	1	05	VI_5
	VI_6	0	0	0	0	0	1	1	0	06	VI_6
	VI_7	0	0	0	0	1	0	0	0	08	VI_7
	VI_8	0	0	0	0	1	0	0	1	09	VI_8
	VI_9	0	0	0	0	1	0	1	0	0A	VI_9
	VI_10	0	0	0	0	1	1	0	0	0C	VI_10
	VI_11	0	0	0	0	1	1	0	1	0D	VI_11
	VI_12	0	0	0	0	1	1	1	0	0E	VI_12
S-Video	VI_1(Y), VI_7(C)	0	1	0	0	0	0	0	0	40	VI_1(Y)
	VI_2(Y), VI_8(C)	0	1	0	0	0	0	0	1	41	VI_2(Y)
	VI_3(Y), VI_9(C)	0	1	0	0	0	0	1	0	42	VI_3(Y)
	VI_1(Y), VI_10(C)	0	1	0	0	0	0	0	0	50	VI_1(Y)
	VI_2(Y), VI_11(C)	0	1	0	1	0	0	0	1	51	VI_2(Y)
	VI_3(Y), VI_12(C)	0	1	0	1	0	0	1	0	52	VI_3(Y)
	VI_4(Y), VI_7(C)	0	1	0	1	0	1	0	0	44	VI_4(Y)
	VI_5(Y), VI_8(C)	0	1	0	0	0	1	0	1	45	VI_5(Y)
	VI_6(Y), VI_9(C)	0	1	0	0	0	1	1	0	46	VI_6(Y)
	VI_4(Y), VI_10(C)	0	1	0	0	0	1	0	0	54	VI_4(Y)
	VI_5(Y), VI_11(C)	0	1	0	1	0	1	0	1	55	VI_5(Y)
	VI_6(Y), VI_12(C)	0	1	0	1	0	1	1	0	56	VI_6(Y)
YPbPr	VI_10(Pb), VI_1(Y), VI_7(Pr)	1	0	0	1	0	0	0	0	90	VI_1(Y)
	VI_11(Pb), VI_2(Y), VI_8(Pr)	1	0	0	1	0	0	0	1	91	VI_2(Y)
	VI_12(Pb), VI_3(Y), VI_9(Pr)	1	0	0	1	0	0	1	0	92	VI_3(Y)
	VI_10(Pb), VI_4(Y), VI_7(Pr)	1	0	0	1	0	1	0	0	94	VI_4(Y)
	VI_11(Pb), VI_5(Y), VI_8(Pr)	1	0	0	1	0	1	0	1	95	VI_5(Y)
	VI_12(Pb), VI_6(Y), VI_9(Pr)	1	0	0	1	0	1	1	0	96	VI_6(Y)
SCART	VI_10(B), VI_4(G), VI_7(R), VI_1(CVBS)	1	1	0	0	0	0	0	0	C0	VI_1(CVBS)
	VI_11(B), VI_5(G), VI_8(R), VI_2(CVBS)	1	1	0	0	0	0	0	1	C1	VI_2(CVBS)
	VI_12(B), VI_6(G), VI_9(R), VI_3(CVBS)	1	1	0	0	0	0	1	0	C2	VI_3(CVBS)

Table 3-5. AFE Gain Control

Subaddress	01h
Default	0Fh

7	6	5	4	3	2	1	0
Reserved				1	1	1	AGC

Bit 3: 1b must be written to this bit

Bit 2: 1b must be written to this bit

Bit 1: 1b must be written to this bit

AGC: Controls automatic gain

0 = Manual

1 = Enable auto gain (default)

This setting only affects the analog front-end (AFE). The brightness and contrast controls are not affected by these settings.

Table 3-6. Video Standard Select

Subaddress	02h
Default	00h

7	6	5	4	3	2	1	0
Reserved				Video standard [3:0]			

Video standard [3:0]:

CVBS and S-Video	Component video
0000 = Autoswitch mode (default)	Autoswitch mode (default)
0001 = (M, J) NTSC	Interlaced 525 (480i)
0010 = (B, D, G, H, I, N) PAL	Interlaced 625 (576i)
0011 = (M) PAL	Reserved
0100 = (Combination-N) PAL	Reserved
0101 = NTSC 4.43	Reserved
0110 = SECAM	Reserved
0111 = PAL 60	Reserved
1000 = Reserved	Reserved
1001 = Reserved	NTSC Progressive 525 (480p)
1010 = Reserved	PAL Progressive 625 (576p)

The user can force the device to operate in a particular video standard mode by writing the appropriate value into this register. Changing these bits will cause some register settings to be reset to their defaults.

Table 3-7. Operation Mode

Subaddress	03h
Default	00h

7	6	5	4	3	2	1	0
Reserved							Power save

Power save

0 = Normal operation (default)

1 = Power save mode. Reduces the clock speed of the internal processor and switches off the ADCs. I²C interface is active and all current operating settings are preserved.

Table 3-8. Autoswitch Mask

Subaddress	04h
Default	23h

7	6	5	4	3	2	1	0
Reserved	PAL 60	SECAM	NTSC 4.43	(Nc) PAL	(M) PAL	PAL	(M, J) NTSC

Autoswitch mode mask: Limits the video formats between which autoswitch is possible. See register 30h for masking the progressive modes.

PAL 60

- 0 = Autoswitch does not include PAL 60 (default)
- 1 = Autoswitch includes PAL 60

SECAM

- 0 = Autoswitch does not include SECAM
- 1 = Autoswitch includes SECAM (default)

NTSC 4.43

- 0 = Autoswitch does not include NTSC 4.43 (default)
- 1 = Autoswitch includes NTSC 4.43

(Nc) PAL

- 0 = Autoswitch does not include (Nc) PAL (default)
- 1 = Autoswitch includes (Nc) PAL

(M) PAL

- 0 = Autoswitch does not include (M) PAL (default)
- 1 = Autoswitch includes (M) PAL

PAL

- 0 = Reserved
- 1 = Autoswitch includes (B, D, G, H, I, N) PAL (default)

(M, J) NTSC

- 0 = Reserved
- 1 = Autoswitch includes (M, J) NTSC (default)

Note: Bits 1 and 0 must always be 11b.

Table 3-9. Color Killer

Subaddress	05h
Default	10h

7	6	5	4	3	2	1	0
Reserved	Automatic color killer		Color killer threshold [4:0]				

Automatic color killer:

- 00 = Automatic mode (default)
- 01 = Reserved
- 10 = Color killer enabled, the UV terminals are forced to a zero color state
- 11 = Color killer disabled

Color killer threshold [4:0]:

- 11111 = 31 (maximum)
- 10000 = 16 (default)
- 00000 = 0 (minimum)

Table 3-10. Luminance Processing Control 1

Subaddress	06h						
Default	00h						
7	6	5	4	3	2	1	0
Reserved	Pedestal	Reserved	VBI raw	Reserved	Luminance signal delay [2:0]		

Pedestal:

0 = 7.5 IRE pedestal is present on the analog video input signal (default)

1 = Pedestal is not present on the analog video input signal

VBI raw:

0 = Disable (default)

1 = Enable

During the duration of the vertical blanking as defined by VBLK start and stop registers 22h through 25h, the chroma samples are replaced by luma samples. This feature may be used to support VBI processing performed by an external device during the vertical blanking interval. To use this bit, the output format must be the 10-bit, ITU-R BT.656 mode.

Luminance signal delay [2:0]: Luminance signal delays respect to chroma signal in 1 × pixel clock increments.

011 = 3 pixel clocks delay

010 = 2 pixel clocks delay

001 = 1 pixel clock delay

000 = 0 pixel clock delay (default)

111 = -1 pixel clock delay

110 = -2 pixel clocks delay

101 = -3 pixel clocks delay

100 = 0 pixel clock delay

Table 3-11. Luminance Processing Control 2

Subaddress	07h						
Default	00h						
7	6	5	4	3	2	1	0
Luma filter select [1:0]		Reserved		Peaking gain [1:0]		Reserved	

Luma filter selected [1:0]:

00 = Luminance adaptive comb enable (default on CVBS and SECAM)

01 = Luminance adaptive comb disable (trap filter selected)

10 = Luma comb/trap filter bypassed (default on S-Video, component mode)

11 = Reserved

Peaking gain [1:0]:

00 = 0 (default)

01 = 0.5

10 = 1

11 = 2

Table 3-12. Luminance Processing Control 3

Subaddress	08h
Default	00h

7	6	5	4	3	2	1	0
Reserved						Trap filter select [1:0]	

Trap filter select[1:0] selects one of the four trap filters to produce the luminance signal by removing the chrominance signal from the composite video signal. The stop band of the chroma trap filter is centered at the chroma subcarrier frequency with stopband bandwidth controlled by the two control bits. Changing this register will trade luma resolution for dot crawl.

Trap filter stop band bandwidth (MHz):

Filter select [1:0]	NTSC ITU-R 601	PAL ITU-R 601
00 (default)	1.2129	1.2129
01	0.8701	0.8701
10	0.7183	0.7383
11	0.5010	0.5010

Table 3-13. Luminance Brightness

Subaddress	09h
Default	80h

7	6	5	4	3	2	1	0
Brightness [7:0]							

Brightness [7:0]: This register works for CVBS and S-Video luminance. See subaddress 2Fh.

0000 0000 = 0 (dark)

1000 0000 = 128 (default)

1111 1111 = 255 (bright)

For composite and S-Video outputs, the output black level relative to the nominal black level (64 out of 1024) as a function of the Brightness[7:0] setting is as follows.

$$\text{Black Level} = \text{nominal_black_level} + (M_B + 1) \times (\text{Brightness}[7:0] - 128)$$

Where M_B is the brightness multiplier setting in the Brightness and Contrast Range Extender register at I²C subaddress 2Fh.

Table 3-14. Luminance Contrast

Subaddress	0Ah
Default	80h

7	6	5	4	3	2	1	0
Contrast [7:0]							

Contrast [7:0]: This register works for CVBS and S-Video luminance. See subaddress 2Fh.

0000 0000 = 0 (minimum contrast)

1000 0000 = 128 (default)

1111 1111 = 255 (maximum contrast)

For composite and S-Video outputs, the total luminance gain relative to the nominal luminance gain as a function of the Contrast [7:0] setting is as follows.

$$\text{Luminance Gain} = (\text{nominal_luminance_gain}) \times [\text{Contrast}[7:0] / 64 / (2^{M_C}) + M_C - 1]$$

Where M_C is the contrast multiplier setting in the Brightness and Contrast Range Extender register at I²C subaddress 2Fh.

Table 3-15. Chrominance Saturation

Subaddress	0Bh
Default	80h

7	6	5	4	3	2	1	0
Saturation [7:0]							

Saturation [7:0]: This register works for CVBS and S-Video chrominance.

0000 0000 = 0 (no color)

1000 0000 = 128 (default)

1111 1111 = 255 (maximum)

For composite and S-Video outputs, the total chrominance gain relative to the nominal chrominance gain as a function of the Saturation [7:0] setting is as follows.

$$\text{Chrominance Gain} = (\text{nominal_chrominance_gain}) \times (\text{Saturation}[7:0] / 128)$$

Table 3-16. Chroma Hue

Subaddress	0Ch
Default	00h

7	6	5	4	3	2	1	0
Hue [7:0]							

Hue [7:0] (does not apply to a component or SECAM video):

0111 1111 = 180 degrees

0000 0000 = 0 degrees (default)

1000 0000 = -180 degrees

Table 3-17. Chrominance Processing Control 1

Subaddress	0Dh
Default	00h

7	6	5	4	3	2	1	0
3DYC	TBC		Reserved	Chroma adaptive comb enable	3DNR	Automatic color gain control [1:0]	

3DYC, frame recursive noise reduction (3DNR), and time base correction (TBC) can be used simultaneously or independently.

Memory requirements:

3DYC	3DNR	Function	External Memory Required
0	0	None	None
1	0	3DYC only	16 Mbits
0	1	3DNR only	16 Mbits
1	1	3DYC + 3DNR	32 Mbits

Note: The SDRAM configuration register must be programmed before enabling features that require the SDRAM. Failure to do so will result in incorrect operation of the memory controller

3DYC:

0 = Disable; the 2D adaptive 5-line comb filter is enabled (default)

1 = Enable

3DYC enhances 2D Y/C separation by utilizing temporal-based, or frame-based information. 3DYC requires the use of the frame buffer memory and can be used simultaneously with 3DNR and TBC.

TBC:

00 = Disable (default)

01 = On

10 = Automatic selection

11 = Automatic selection

Line-based time correction corrects for horizontal phase errors encountered during video decoding up to ± 80 pixels of error. TBC can be used simultaneously with 3DYC and 3DNR. TBC does not require external memory.

Chrominance adaptive comb enable:

0 = Enable (default)

1 = Disable

This bit is effective on composite video only.

3DNR:

0 = Disable (default)

1 = Enable

Frame recursive noise reduction minimizes the amount of noise in interlaced CVBS, S-Video, or component inputs. 3DNR requires the use of the frame buffer memory and can be used simultaneously with 3DYC and TBC.

Note: Noise reduction can not be used on progressive inputs.

Automatic color gain control (ACGC) [1:0]:

00 = ACGC enabled (default)

01 = Reserved

10 = ACGC disabled, ACGC set to the nominal value

11 = ACGC frozen to the previously set value

Table 3-18. Chrominance Processing Control 2

Subaddress	0Eh
Default	0Ch

7	6	5	4	3	2	1	0
Reserved				PAL compensation	WCF	Chrominance filter select [1:0]	

This register trades chroma bandwidth for less false color.

PAL compensation: This bit has no effect in NTSC and SECAM modes.

0 = Disabled

1 = Enabled (default)

Wideband chroma LPF filter (WCF):

0 = Disabled

1 = Enabled (default)

Chrominance filter select [1:0]:

00 = Disabled (default)

01 = Notch 1

10 = Notch 2

11 = Notch 3

Table 3-19. R/Pr Saturation

Subaddress	10h
Default	80h

7	6	5	4	3	2	1	0
R/Pr saturation [7:0]							

R/Pr saturation [7:0]: This register works only with YPbPr component video. For RGB video, use the AFE gain registers.

0000 0000 = minimum

1000 0000 = default

1111 1111 = maximum

For component video, the total R/Pr gain relative to the nominal R/Pr gain as a function of the R/Pr saturation[7:0] setting is as follows.

$$\text{R/Pr Gain} = (\text{nominal_chrominance_gain}) \times (\text{R/Pr saturation}[7:0] / 128)$$

Table 3-20. G/Y Saturation

Subaddress	11h
Default	80h

7	6	5	4	3	2	1	0
G/Y contrast [7:0]							

G/Y contrast [7:0]: This register works only with YPbPr component video. For RGB video, use the AFE gain registers.

0000 0000 = minimum

1000 0000 = default

1111 1111 = maximum

For component video outputs, the total luminance gain relative to the nominal luminance gain as a function of the G/Y contrast[7:0] is as follows.

$$\text{G/Y Gain} = (\text{nominal_luminance_gain}) \times (\text{G/Y contrast}[7:0] / 128)$$

Table 3-21. B/Pb Saturation

Subaddress	12h
Default	80h

7	6	5	4	3	2	1	0
B/Pb saturation[7:0]							

B/Pb saturation [7:0]: This register works only with YPbPr component video. For RGB video, use the AFE gain registers.

0000 0000 = minimum

1000 0000 = default

1111 1111 = maximum

For component video, the total Pb gain relative to the nominal Pb gain as a function of the B/Pb saturation[7:0] setting is as follows.

$$\text{B/Pb Gain} = (\text{nominal_chrominance_gain}) \times (\text{B/Pb saturation}[7:0] / 128)$$

Table 3-22. G/Y Brightness

Subaddress	14h
Default	80h

7	6	5	4	3	2	1	0
G/Y brightness[7:0]							

G/Y brightness [7:0]: This register works only with YPbPr component video. For RGB video, use the AFE gain registers.

0000 0000 = minimum

1000 0000 = default

1111 1111 = maximum

For component video, the output black level relative to the nominal black level (64 out of 1024) as a function of G/Y brightness[7:0] is as follows.

$$\text{Black Level} = \text{nominal_black_level} + (\text{G/Y brightness}[7:0] - 128)$$

Table 3-23. AVID Start Pixel

Subaddress	16h–17h
Default	55h/5Fh

Subaddress	7	6	5	4	3	2	1	0	
16h	AVID start [7:0]								
17h	Reserved			AVID active	Reserved			AVID start [9:8]	

AVID active

0 = AVID out active in VBLK (default)

1 = AVID out inactive in VBLK

AVID start [9:0]: AVID start pixel number, this is a absolute pixel location from HS start pixel 0.

The TVP5160 decoder updates the AVID start only when the AVID start MSB byte is written to. The AVID start pixel register also controls the position of the SAV code. If these registers are modified, then the TVP5160 decoder retains the values for each video standard until the device is reset. The values for a particular video standard must be set by forcing the decoder to the desired video standard first using register 02h then setting this register. This must be repeated for each video standard where the default values need to be changed.

Table 3-24. AVID Stop Pixel

Subaddress	18h–19h							
Default	325h/32Fh							
Subaddress	7	6	5	4	3	2	1	0
18h	AVID stop [7:0]							
19h	Reserved						AVID stop [9:8]	

AVID stop [9:0]: AVID stop pixel number. The number of pixels of active video must be an even number. This is an absolute pixel location from HS start pixel 0.

The TVP5160 decoder updates the AVID stop only when the AVID stop MSB byte is written to. The AVID stop pixel register also controls the position of the EAV code. If these registers are modified, then the TVP5160 decoder retains the values for each video standard until the device is reset. The values for a particular video standard must be set by forcing the decoder to the desired video standard first using register 02h then setting this register. This must be repeated for each video standard where the default values need to be changed.

Table 3-25. HS Start Pixel

Subaddress	1Ah–1Bh							
Default	000h							
Subaddress	7	6	5	4	3	2	1	0
1Ah	HS start [7:0]							
1Bh	Reserved						HS start [9:8]	

HS start pixel [9:0]: This is an absolute pixel location from HS start pixel 0.

The TVP5160 decoder updates the HS start only when the HS start MSB byte is written to. If these registers are modified, then the TVP5160 decoder retains the values for each video standard until the device is reset. The values for a particular video standard must be set by forcing the decoder to the desired video standard first using register 02h then setting this register. This must be repeated for each video standard where the default values need to be changed.

Table 3-26. HS Stop Pixel

Subaddress	1Ch–1Dh							
Default	040h							
Subaddress	7	6	5	4	3	2	1	0
1Ch	HS stop [7:0]							
1Dh	Reserved						HS stop [9:8]	

HS stop [9:0]: This is an absolute pixel location from HS start pixel 0.

The TVP5160 decoder updates the HS stop only when the HS stop MSB byte is written to. If these registers are modified, then the TVP5160 decoder retains the values for each video standard until the device is reset. The values for a particular video standard must be set by forcing the decoder to the desired video standard first using register 02h then setting this register. This must be repeated for each video standard where the default values need to be changed.

Table 3-27. VS Start Line

Subaddress	1Eh–1Fh							
Default	004h/001h							
Subaddress	7	6	5	4	3	2	1	0
1Eh	VS start [7:0]							
1Fh	Reserved						VS start [9:8]	

VS start [9:0]: This is an absolute line number.

The TVP5160 decoder updates the VS start only when the VS start MSB byte is written to. If these registers are modified, then the TVP5160 decoder retains the values for each video standard until the device is reset. The values for a particular video standard must be set by forcing the decoder to the desired video standard first using register 02h then setting this register. This must be repeated for each video standard where the default values need to be changed.

Table 3-28. VS Stop Line

Subaddress	20h–21h							
Default	004h/001h							
Subaddress	7	6	5	4	3	2	1	0
20h	VS stop [7:0]							
21h	Reserved						VS stop [9:8]	

VS stop [9:0]: This is an absolute line number.

The TVP5160 decoder updates the VS stop only when the VS stop MSB byte is written to. If these registers are modified, then the TVP5160 decoder retains the values for each video standard until the device is reset. The values for a particular video standard must be set by forcing the decoder to the desired video standard first using register 02h then setting this register. This must be repeated for each video standard where the default values need to be changed.

Table 3-29. VBLK Start Line

Subaddress	22h–23h							
Default	001h/26Fh							
Subaddress	7	6	5	4	3	2	1	0
22h	VBLK start [7:0]							
23h	Reserved						VBLK start [9:8]	

VBLK start [9:0]: This is an absolute line number.

The TVP5160 decoder updates the VBLK start line only when the VBLK start MSB byte is written to. If these registers are modified, then the TVP5160 decoder retains the values for each video standard until the device is reset. The values for a particular video standard must be set by forcing the decoder to the desired video standard first using register 02h then setting this register. This must be repeated for each video standard where the default values need to be changed.

Table 3-30. VBLK Stop Line

Subaddress	24h–25h							
Default	001h/26Fh							
Subaddress	7	6	5	4	3	2	1	0
24h	VBLK stop [7:0]							
25h	Reserved						VBLK stop [9:8]	

VBLK stop [9:0]: This is an absolute line number.

The TVP5160 decoder updates the VBLK stop only when the VBLK stop MSB byte is written to. If these registers are modified, then the TVP5160 decoder retains the values for each video standard until the device is reset. The values for a particular video standard must be set by forcing the decoder to the desired video standard first using register 02h then setting this register. This must be repeated for each video standard where the default values need to be changed.

Table 3-31. Embedded Sync Offset Control 1

Subaddress	26h							
Default	00h							
	7	6	5	4	3	2	1	0
	Offset [7:0]							

This register allows the line position of the embedded F bit and V bit signals to be offset from the 656 standard positions. This register is only applicable to input video signals with standard number of lines.

```

0111 1111 = 127 lines
:
0000 0001 = 1 line
0000 0000 = 0 line
1111 1111 = -1 line
:
1000 0000 = -128 lines

```

Table 3-32. Embedded Sync Offset Control 2

Subaddress	27h
Default	00h

7	6	5	4	3	2	1	0
Offset [7:0]							

This register allows the line relationship between the embedded F bit and V bit signals to be offset from the 656 standard positions, and moves F relative to V. This register is only applicable to input video signals with standard number of lines.

0111 1111 = 127 lines
 ⋮
 0000 0001 = 1 line
 0000 0000 = 0 line
 1111 1111 = -1 line
 ⋮
 1000 0000 = -128 lines

Table 3-33. Fast-Switch Control

Subaddress	28h
Default	C0h

7	6	5	4	3	2	1	0
Mode [2:0]			Reserved			Polarity FSO	Polarity FSS

Mode [2:0]:

000 = CVBS ↔ SCART
 001 = CVBS, S_VIDEO ↔ Digital overlay
 010 = Component ↔ Digital overlay
 011 = (CVBS ↔ SCART) ↔ Digital overlay
 100 = (CVBS ↔ Digital overlay) ↔ SCART
 101 = CVBS ↔ (SCART ↔ Digital overlay)
 110 = Composite (default)
 111 = Component

Polarity FSO:

0 = If FSO = 0, then output = YPbPr
 If FSO = 1, then output = Digital RGB (default)
 1 = If FSO = 0, then output = Digital RGB
 If FSO = 1, then output = YPbPr

Polarity FSS:

0 = If FSO = 0, then output = RGB
 If FSO = 1, then output = CVBS (4A) (default)
 1 = If FSO = 0, then output = CVBS (4A)
 If FSO = 1, then output = RGB

See TI application note [SLEA016](#), *TVP5146 SCART and OSD*, for more information on SCART overlay and digital overlay programming.

Table 3-34. Fast-Switch Overlay Delay

Subaddress	29h						
Default	17h						
7	6	5	4	3	2	1	0
Reserved			FSO delay [4:0]				

Overlay delay [4:0]: Adjusts delay between digital RGB and FSO

11111 = 8 pixel delay
 ⋮
 11000 = 1 pixel delay
 10111 = 0 delay (default)
 10110 = –1 pixel delay
 ⋮
 00000 = –23 pixel delay

When SCART mode is active (RGB component) the recommended setting for this register is 1Bh; otherwise, 17h is recommended.

Table 3-35. Fast-Switch SCART Delay

Subaddress	2Ah						
Default	1Ch						
7	6	5	4	3	2	1	0
Reserved			FSS delay [4:0]				

FSS delay [4:0]: Adjusts delay between FSS and component RGB

11111 = 3 pixel delay
 ⋮
 11101 = 1 pixel delay
 11100 = 0 delay (default)
 11011 = –1 pixel delay
 ⋮
 00000 = –23 pixel delay

Table 3-36. Overlay Delay

Subaddress	2Bh						
Default	12h						
7	6	5	4	3	2	1	0
Reserved			Overlay delay [4:0]				

Overlay delay[4:0]: Adjusts delay between digital RGB and component video

11111 = 13 pixel delay
 ⋮
 10011 = 1 pixel delay
 10010 = 0 delay (default)
 10001 = –1 pixel delay
 ⋮
 00000 = –18 pixel delay

When SCART mode is active (RGB component) the recommended setting for this register is 16h; otherwise, 12h is recommended.

Table 3-37. SCART Delay

Subaddress	2Ch
Default	56h

7	6	5	4	3	2	1	0
Reserved	SCART delay [6:0]						

This register must be changed in multiples of 2 to maintain the CbCr relationship. SCART delay[6:0]: Adjusts delay between CVBS and component video.

101 1111 = 9 pixel delay
 ⋮
 101 0111 = 1 pixel delay
 101 0110 = 0 delay (default)
 101 0101 = -1 pixel delay
 ⋮
 000 0000 = -86 pixel delay

Table 3-38. CTI Control

Subaddress	2Eh
Default	00h

7	6	5	4	3	2	1	0
CTI coring [3:0]				CTI gain [3:0]			

CTI coring [3:0]: 4-bit CTI coring limit control values, unsigned, linear control range from 0 to ±60, step size = 4

1111 = ±60
 ⋮
 0001 = ±4
 0000 = 0 (default)

CTI gain [3:0]: 4-bit CTI gain control values, unsigned, linear control range from 0 to 15/16, step size = 1/16

1111 = 15/16
 ⋮
 0001 = 1/16
 0000 = 0 (default)

Table 3-39. Brightness and Contrast Range Extender

Subaddress	2Fh
Default	00h

7	6	5	4	3	2	1	0
Reserved			Contrast multiplier	Brightness multiplier [3:0]			

Contrast multiplier [4]: (MC) Increases the contrast control range for composite and S-Video modes.

0 = 2x contrast control range (default), Gain = $n/64 - 1$ where n is the contrast control and $64 \leq n \leq 255$
 1 = Normal contrast control range, Gain = $n/128$ where n is the contrast control and $0 \leq n \leq 255$

Brightness multiplier [3:0]: (MB) Increases the brightness control range for composite and S-Video modes from 1x to 16x.

0h = 1x(default)
 1h = 2x
 3h = 4x
 7h = 8x
 Fh = 16x

Note: In general, the brightness multiplier should be set to 0h for 10-bit outputs and 3h for 8-bit outputs

Table 3-40. Component Autoswitch Mask

Subaddress	30h
Default	00h

7	6	5	4	3	2	1	0
Reserved				576i	480i	576p	480p

Masks the component progressive/interlaced modes from being processed in the autoswitch routines.

480p

- 0 = Autoswitch does not include 480p progressive modes (default)
- 1 = Autoswitch includes 480p progressive mode

576p

- 0 = Autoswitch does not include 576p progressive mode (default)
- 1 = Autoswitch includes 576p progressive mode

480i

- 0 = Autoswitch does not include 480i interlaced modes (default)
- 1 = Autoswitch includes 480i interlaced mode

576i

- 0 = Autoswitch does not include 576i interlaced mode (default)
- 1 = Autoswitch includes 576i interlaced mode

Table 3-41. Sync Control

Subaddress	32h
Default	00h

7	6	5	4	3	2	1	0
Reserved			Polarity FID	Polarity VS	Polarity HS	VS/VBLK	HS/CS

Polarity FID: determines polarity of FID pin

- 0 = First field high, second field low (default)
- 1 = First field low, second field high

Polarity VS: determines polarity of VS pin

- 0 = Active low (default)
- 1 = Active high

Polarity HS: determines polarity of HS pin

- 0 = Active low (default)
- 1 = Active high

VS/VBLK:

- 0 = VS pin outputs vertical sync (default)
- 1 = VS pin outputs vertical blank

HS/CS:

- 0 = HS pin outputs horizontal sync (default)
- 1 = HS pin outputs composite sync

Table 3-42. Output Formatter Control 1

Subaddress	33h
Default	40h

7	6	5	4	3	2	1	0
Reserved	YCbCr code range	CbCr code	Reserved		Output format [2:0]		

YCbCr output code range:

- 0 = ITU-R BT.601 coding range (Y ranges from 64 to 940, Cb and Cr range from 64 to 960)
- 1 = Extended coding range (Y, Cb, and Cr range from 4 to 1016) (default)

CbCr code format:

- 0 = Offset binary code (2s complement + 512) (default)
- 1 = Straight binary code (2s complement)

Output format [2:0]:

- 000 = 10-bit 4:2:2 (pixel × 2 rate) with embedded syncs (ITU-R BT.656)
- 001 = 20-bit 4:2:2 (pixel rate) with discrete syncs
- 010 = Reserved
- 011 = 10-bit 4:2:2 with discrete syncs
- 100 = 20-bit 4:2:2 (pixel rate) with embedded syncs
- 101–111 = Reserved

Note: 10-bit mode is also used for raw VBI output mode when bit 4 (VBI raw) in the luminance processing control 1 register at subaddress 06h is set.

Table 3-43. Output Formatter Control 2

Subaddress	34h
Default	00h

7	6	5	4	3	2	1	0
Reserved			Data enable	"Blue" Screen Output [1:0]	Clock polarity	SCLK enable	

Data enable: Y[9:0] and C[9:0] output enable

- 0 = Y[9:0] and C[9:0] high-impedance (default)
- 1 = Y [9:0] and C[9:0] active

"Blue" Screen Output [1:0]:

- 00 = Normal operation (default)
- 01 = "Blue" screen out when the TVP5160 decoder detects lost lock (with tuner input but not with VCR)
- 10 = Force "Blue" screen out
- 11 = Reserved

Fully programmable color of "blue screen" to support clean input/channel switching. When enabled, in case of lost lock, or when forced, the decoder waits until the end of the current frame, then switches the output data to a programmable color. Once displaying the "blue screen", the inputs and or RF channel can be switched without causing snow or noise to be displayed on the digital output data. Once the inputs have settled, the "blue screen" can be disabled, and the decoder then waits until the end of the current video frame before re-enabling the video stream data to the output ports.

Clock polarity:

- 0 = Data clocked out on the falling edge of SCLK (default)
- 1 = Data clocked out on the rising edge of SCLK

SCLK enable:

- 0 = SCLK outputs are high-impedance (default)
- 1 = SCLK outputs are enabled

Table 3-44. Output Formatter Control 3

Subaddress	35h
Default	FFh

7	6	5	4	3	2	1	0
GPIO [1:0]		AVID [1:0]		GLCO [1:0]		FID [1:0]	

GPIO [1:0]: GPIO pin (pin 82) function select

- 00 = GPIO is 0b output
- 01 = GPIO is 1b output
- 10 = Reserved
- 11 = GPIO in logic input (default)

AVID [1:0]: AVID pin function select

- 00 = AVID is 0b output
- 01 = AVID is 1b output
- 10 = AVID is active video indicator output
- 11 = AVID is logic input (default). In this mode the pin is used as GPIO.

GLCO [1:0]: GLCO pin function select

- 00 = GLCO is 0b output
- 01 = GLCO is 1b output
- 10 = GLCO is genlock output
- 11 = GLCO is logic input (default). In this mode the pin is used as GPIO.

FID [1:0]: FID pin function select

- 00 = FID is 0b output
- 01 = FID is 1b output
- 10 = FID is FID output
- 11 = FID is logic input (default). In this mode the pin is used as GPIO.

Table 3-45. Output Formatter Control 4

Subaddress	36h
Default	FFh

7	6	5	4	3	2	1	0
VS/VBLK [1:0]		HS/CS [1:0]		C_1 [1:0]		C_0 [1:0]	

VS/VBLK [1:0]: VS pin function select

- 00 = VS is 0b output
- 01 = VS is 1b output
- 10 = VS/VBLK is vertical sync or vertical blank output corresponding to bit 1 (VS/VBLK) in the sync control register at subaddress 32h (see Section 4.1.37)
- 11 = VS is logic input (default). In this mode the pin is used as GPIO.

HS/CS [1:0]: HS pin function select

- 00 = HS is 0b output
- 01 = HS is 1b output
- 10 = HS/CS is horizontal sync or composite sync output corresponding to bit 0 (HS/CS) in the sync control register at subaddress 32h (see Section 4.1.37)
- 11 = HS is logic input (default). In this mode the pin is used as GPIO.

C_1 [1:0]: C_1 pin function select

- 00 = C_1 is 0b output
- 01 = C_1 is 1b output
- 10 = Reserved
- 11 = C_1 is logic input (default)

C_0 [1:0]: C_0 pin function select

- 00 = C_0 is 0b output
- 01 = C_0 is 1b output
- 10 = Reserved
- 11 = C_0 is logic input (default)

Table 3-46. Output Formatter Control 5

Subaddress	37h
Default	FFh

7	6	5	4	3	2	1	0
C_5 [1:0]		C_4 [1:0]		C_3 [1:0]		C_2 [1:0]	

C_5 [1:0]: C_5 pin function select

00 = C_5 is 0b output

01 = C_5 is 1b output

10 = Reserved

11 = C_5 is logic input (default). In this mode the pin is used as GPIO.

C_4 [1:0]: C_4 pin function select

00 = C_4 is 0b output

01 = C_4 is 1b output

10 = Reserved

11 = C_4 is logic input (default). In this mode the pin is used as GPIO.

C_3 [1:0]: C_3 pin function select

00 = C_3 is 0b output

01 = C_3 is 1b output

10 = Reserved

11 = C_3 is logic input (default). In this mode the pin is used as GPIO.

C_2 [1:0]: C_2 pin function select

00 = C_2 is 0b output

01 = C_2 is 1b output

10 = Reserved

11 = C_2 is logic input (default). In this mode the pin is used as GPIO.

Table 3-47. Output Formatter Control 6

Subaddress	38h
Default	FFh

7	6	5	4	3	2	1	0
C_9 [1:0]		C_8 [1:0]		C_7 [1:0]		C_6 [1:0]	

C_9 [1:0]: C_9 pin function select

00 = C_9 is 0b output

01 = C_9 is 1b output

10 = Reserved

11 = C_9 is logic input (default). In this mode the pin is used as GPIO.

Note: If overlay is enabled, then C[9] functions as FSO regardless of the setting of register 38h.

C_8 [1:0]: C_8 pin function select

00 = C_8 is 0b output

01 = C_8 is 1b output

10 = Reserved

11 = C_8 is logic input (default). In this mode the pin is used as GPIO.

C_7 [1:0]: C_7 pin function select

00 = C_7 is 0b output

01 = C_7 is 1b output

10 = Reserved

11 = C_7 is logic input (default). In this mode the pin is used as GPIO.

C_6 [1:0]: C_6 pin function select

00 = C_6 is 0b output

01 = C_6 is 1b output

10 = Reserved

11 = C_6 is logic input (default). In this mode the pin is used as GPIO.

Table 3-48. Clear Lost Lock Detect

Subaddress	39h
Default	00h

7	6	5	4	3	2	1	0
Reserved							Clear lost lock detect

Clear lost lock detect: Clear bit 4 (lost lock detect) in the status 1 register at subaddress 3Ah

0 = No effect (default)

1 = Clears bit 4 in the status 1 register

Table 3-49. Status 1

Subaddress	3Ah
	Read only

7	6	5	4	3	2	1	0
Peak white detect status	Line-alternating status	Field rate status	Lost lock detect	Color subcarrier lock status	Vertical sync lock status	Horizontal sync lock status	TV/VCR status

Peak white detect status:

0 = Peak white is not detected

1 = Peak white is detected

Line-alternating status:

0 = Non line-alternating

1 = Line-alternating

Field rate status:

0 = 60 Hz

1 = 50 Hz

Lost lock detect:

0 = No lost lock since this bit was last cleared

1 = Lost lock since this bit was last cleared

Color subcarrier lock status:

0 = Color subcarrier is not locked

1 = Color subcarrier is locked

Vertical sync lock status:

0 = Vertical sync is not locked

1 = Vertical sync is locked

Horizontal sync lock status:

0 = Horizontal sync is not locked

1 = Horizontal sync is locked TV/VCR status: 0 = TV 1 = VCR

Table 3-50. Status 2

Subaddress	3Bh							
	Read only							
	7	6	5	4	3	2	1	0
Signal present	Weak signal detection	PAL switch polarity	Field sequence status	Color killed	Macrovision detection [2:0]			

Signal present detection:

0 = Signal not present

1 = Signal present

Weak signal detection:

0 = No weak signal

1 = Weak signal mode

PAL switch polarity of first line of odd field:

0 = PAL switch is 0b

1 = PAL switch is 1b

Field sequence status:

0 = Even field

1 = Odd field

Color killed:

0 = Color killer not active

1 = Color killer activated

Macrovision detection [2:0]:

000 = No copy protection

001 = AGC pulses/pseudo syncs present (Type 1)

010 = 2-line colorstripe only present

011 = AGC pulses/pseudo syncs and 2-line colorstripe present (Type 2)

100 = Reserved

101 = Reserved

110 = 4-line colorstripe only present

111 = AGC pulses/pseudo syncs and 4-line colorstripe present (Type 3)

Table 3-51. AGC Gain Status

Subaddress	3Ch–3Dh							
	Read only							
Subaddress	7	6	5	4	3	2	1	0
3Ch	Fine Gain [7:0]							
3Dh	Coarse Gain [3:0]				Fine Gain[11:8]			

Fine gain [11:0]: This register provides the fine gain value of sync channel.

1111 1111 1111 = 1.9995

1000 0000 0000 = 1

0100 0000 0000 = 0.5

Coarse gain [3:0]: This register provides the coarse gain value of sync channel.

1111 = 2

0101 = 1

0000 = 0.5

These AGC gain status registers are updated automatically by the TVP5160 decoder with AGC on, in manual gain control mode these register values are not updated by the TVP5160 decoder.

Because this register is a multi-byte register, it is necessary to capture the setting into the register to ensure that the value is not updated between reading the lower and upper bytes. To cause this register to capture the current settings, bit 0 of I2C register 97h (status request) must be set to 1b. Once the internal processor has updated this register, bit 0 of register 97h is cleared, indicating that both bytes of the AGC gain status register have been updated and can be read. Either byte may be read first, because no further update occurs until bit 0 of 97h is set to 1b again.

Table 3-52. Video Standard Status

Subaddress	3Fh						
	Read only						
7	6	5	4	3	2	1	0
Autoswitch	Reserved			Video standard [3:0]			

Autoswitch mode

0 = Single standard set

1 = Autoswitch mode enabled

Video standard [3:0]:

CVBS and S-Video	Component Video
0000 = Reserved	Reserved
0001 = (M, J) NTSC	Interlaced 525 (480i)
0010 = (B, D, G, H, I, N) PAL	Interlaced 625 (576i)
0011 = (M) PAL	Reserved
0100 = (Combination-N) PAL	Reserved
0101 = NTSC 4.43	Reserved
0110 = SECAM	Reserved
0111 = PAL 60	Reserved
1000 = Reserved	Reserved
1001 = Reserved	Progressive 525 (480p)
1010 = Reserved	Progressive 625 (576p)

This register contains information about the detected video standard that the device is currently operating. When in autoswitch mode, this register can be tested to determine which video standard as has been detected.

Table 3-53. GPIO Input 1

Subaddress	40h						
	Read only						
7	6	5	4	3	2	1	0
C_7	C_6	C_5	C_4	C_3	C_2	C_1	C_0

C_x input status:

0 = Input is a low

1 = Input is a high

These status bits are only valid when pins are used as input and are updated at every line.

Table 3-54. GPIO Input 2

Subaddress	41h						
	Read only						
7	6	5	4	3	2	1	0
AVID	GPIO	GLCO	VS	HS	FID	C_9	C_8

AVID input pin status:

0 = Input is a low

1 = Input is a high

GPIO (Pin 82) input pin status:

0 = Input is a low

1 = Input is a high

GLCO input pin status:

0 = Input is a low

1 = Input is a high

VS input pin status:

0 = Input is a low

1 = Input is a high

HS input status:

0 = Input is a low

1 = Input is a high

FID input status:

0 = Input is a low

1 = Input is a high

C_x input status:

0 = Input is a low

1 = Input is a high

These status bits are only valid when pins are used as input and its states updated at every line.

Table 3-55. Back End AGC Status 1

Subaddress	44h						
	Read only						
7	6	5	4	3	2	1	0
Gain [7:0]							

Current back end AGC ratio = Gain/128

Table 3-56. AFE Coarse Gain for CH 1

Subaddress	46h						
Default	20h						
7	6	5	4	3	2	1	0
CGAIN 1 [3:0]				Reserved			

CGAIN 1 [3:0]: Coarse Gain = $0.5 + (\text{CGAIN } 1)/10$ where $0 \leq \text{CGAIN } 1 \leq 15$

This register only works in manual gain control mode. When AGC is active, writing to any value is ignored.

1111 = 2

1110 = 1.9

1101 = 1.8

...

0010 = 0.7(default)

0001 = 0.6

0000 = 0.5

Table 3-57. AFE Coarse Gain for CH 2

Subaddress	47h
Default	20h

7	6	5	4	3	2	1	0
CGAIN 2 [3:0]				Reserved			

CGAIN 2 [3:0]: Coarse Gain = $0.5 + (\text{CGAIN } 2)/10$ where $0 \leq \text{CGAIN } 2 \leq 15$.

This register only works in manual gain control mode. When AGC is active, writing to any value is ignored.

1111 = 2
1110 = 1.9
1101 = 1.8
⋮
0010 = 0.7(default)
0001 = 0.6
0000 = 0.5

Table 3-58. AFE Coarse Gain for CH 3

Subaddress	48h
Default	20h

7	6	5	4	3	2	1	0
CGAIN 3 [3:0]				Reserved			

CGAIN 3 [3:0]: Coarse Gain = $0.5 + (\text{CGAIN } 3)/10$ where $0 \leq \text{CGAIN } 3 \leq 15$.

This register only works in manual gain control mode. When AGC is active, writing to any value is ignored.

1111 = 2
1110 = 1.9
1101 = 1.8
⋮
0010 = 0.7(default)
0001 = 0.6
0000 = 0.5

Table 3-59. AFE Coarse Gain for CH 4

Subaddress	49h
Default	20h

7	6	5	4	3	2	1	0
CGAIN 4 [3:0]				Reserved			

CGAIN 4 [3:0]: Coarse Gain = $0.5 + (\text{CGAIN } 4)/10$ where $0 \leq \text{CGAIN } 4 \leq 15$.

This register only works in manual gain control mode. When AGC is active, writing to any value is ignored.

1111 = 2
1110 = 1.9
1101 = 1.8
⋮
0010 = 0.7(default)
0001 = 0.6
0000 = 0.5

Table 3-60. AFE Fine Gain for B/Pb

Subaddress	4Ah–4Bh							
Default	900h							
Subaddress	7	6	5	4	3	2	1	0
4Ah	FGAIN 1 [7:0]							
4Bh	Reserved				FGAIN 1 [11:8]			

FGAIN 1 [11:0]: This fine gain applies to component B/Pb.

Fine Gain = $(1/2048) * FGAIN$ where $0 \leq FGAIN 1 \leq 4095$

This register is only updated when the MSB (register 4Bh) is written to.

This register only works in manual gain control mode. When AGC is active, writing to any value is ignored.

1111 1111 1111 = 1.9995

1100 0000 0000 = 1.5

1001 0000 0000 = 1.25 (default)

1000 0000 0000 = 1

0100 0000 0000 = 0.5

0011 1111 1111 to 0000 0000 0000 = Reserved

Table 3-61. AFE Fine Gain for G/Y/Chroma

Subaddress	4Ch–4Dh							
Default	900h							
Subaddress	7	6	5	4	3	2	1	0
4Ch	FGAIN 2 [7:0]							
4Dh	Reserved				FGAIN 2 [11:8]			

FGAIN 2 [11:0]: This gain applies to component G/Y channel or S-Video chroma.

This register is only updated when the MSB (register 4Dh) is written to.

This register only works in manual gain control mode. When AGC is active, writing to any value is ignored.

1111 1111 1111 = 1.9995

1100 0000 0000 = 1.5

1001 0000 0000 = 1.25 (default)

1000 0000 0000 = 1

0100 0000 0000 = 0.5

0011 1111 1111 to 0000 0000 0000 = Reserved

Table 3-62. AFE Fine Gain for R/Pr

Subaddress	4Eh–4Fh							
Default	900h							
Subaddress	7	6	5	4	3	2	1	0
4Eh	FGAIN 3 [7:0]							
4Fh	Reserved				FGAIN 3 [11:8]			

FGAIN 3 [11:0]: This fine gain applies to component R/Pr.

This register is only updated when the MSB (register 4Fh) is written to.

This register only works in manual gain control mode. When AGC is active, writing to any value is ignored.

1111 1111 1111 = 1.9995

1100 0000 0000 = 1.5

1001 0000 0000 = 1.25 (default)

1000 0000 0000 = 1

0100 0000 0000 = 0.5

0011 1111 1111 to 0000 0000 0000 = Reserved

Table 3-63. AFE Fine Gain for CVBS/Luma

Subaddress	50h–51h							
Default	900h							
Subaddress	7	6	5	4	3	2	1	0
50h	FGAIN 4 [7:0]							
51h	Reserved				FGAIN 4 [11:8]			

FGAIN 4 [11:0]: This fine gain applies to CVBS or S-Video luma (see AFE fine gain for Pb register)

This register is only updated when the MSB (register 51h) is written to.

This register only works in manual gain control mode. When AGC is active, writing to any value is ignored.

1111 1111 1111 = 1.9995

1100 0000 0000 = 1.5

1001 0000 0000 = 1.25 (default)

1000 0000 0000 = 1

0100 0000 0000 = 0.5

0011 1111 1111 to 0000 0000 0000 = Reserved

Table 3-64. 656 Version

Subaddress	57h								
Default	00h								
	7	6	5	4	3	2	1	0	
	Reserved						656 version	Reserved	

656 version

0 = Timing confirms to ITU-R BT.656-4 specifications (default)

1 = Timing confirms to ITU-R BT.656-3 specifications

Table 3-65. SDRAM Control

Subaddress	59h							
Default	00h							
	7	6	5	4	3	2	1	0
	Reserved		SDRAM_CLK delay control			Enable	Configuration[1:0]	

Configuration[1:0]

Bit 1	Bit 0	Arrangement	
0	0	2 banks × 2048 rows × 256 columns	16 Mbits
0	1	4 banks × 2048 rows × 256 columns	32 Mbits
1	0	2 banks × 4096 rows × 256 columns	32 Mbits
1	1	4 banks × 4096 rows × 256 columns	64 Mbits

Memories with more rows, columns, and/or banks can be used as long as the minimum requirements are met. Additional rows, columns, and/or banks are ignored and unused by the memory controller.

The memory controller must be configured before enabling 3DYC or 3DNR; otherwise, incorrect operation of the memory controller will result.

Enable:

0 = SDRAM controller disabled (default)

1 = SDRAM controller enabled

SDRAM_CLK delay control[3:0]

This register changes the delay from the default position of SDRAM_CLK in increments of approximately 0.58 ns.

Bit 3	Bit 2	Bit 1	Bit 0	Delay
0	0	0	0	0 (default)
0	0	0	1	0.58 ns
1	0	0	0	1.16 ns
1	1	1	1	9.3 ns

Table 3-66. 3DNR Y Noise Sensitivity

Subaddress	5Ah						
Default	80h						
7	6	5	4	3	2	1	0
Y noise sensitivity[7:0]							

Table 3-67. 3DNR UV Noise Sensitivity

Subaddress	5Bh						
Default	80h						
7	6	5	4	3	2	1	0
UV noise sensitivity[7:0]							

Table 3-68. 3DNR Y Coring Threshold Limit

Subaddress	5Ch						
Default	80h						
7	6	5	4	3	2	1	0
Y coring threshold [7:0]							

Table 3-69. 3DNR UV Coring Threshold Limit

Subaddress	5Dh						
Default	40h						
7	6	5	4	3	2	1	0
UV coring threshold [7:0]							

Table 3-70. 3DNR Low Noise Limit

Subaddress	5Eh						
Default	40h						
7	6	5	4	3	2	1	0
Threshold to indicate when Low Noise Present[7:0]							

This register sets a threshold for low noise present.

Table 3-71. "Blue" Screen Y Control

Subaddress	5Fh						
Default	00h						
7	6	5	4	3	2	1	0
Y value [9:2]							

The Y value of the color screen output when enabled by bit 2 or 3 of the output formatter 2 register is programmable using a 10-bit value. The 8 MSB, bits[9:2], are represented in this register.

The remaining two LSB are found in the "Blue" screen LSB register. The default color screen output is black.

Table 3-72. "Blue" Screen Cb Control

Subaddress	60h						
Default	80h						
7	6	5	4	3	2	1	0
Cb value [9:2]							

The Cb value of the color screen output when enabled by bit 2 or 3 of the output formatter 2 register is programmable using a 10-bit value. The 8 MSB, bits[9:2], are represented in this register.

The remaining two LSB are found in the "Blue" screen LSB register. The default color screen output is black.

Table 3-73. "Blue" Screen Cr Control

Subaddress	61h
Default	80h

7	6	5	4	3	2	1	0
Cr value [9:2]							

The Cr value of the color screen output when enabled by bit 2 or 3 of the output formatter 2 register is programmable using a 10-bit value. The 8 MSB, bits[9:2], are represented in this register. The remaining two LSB are found in the "Blue" screen LSB register. The default color screen output is black.

Table 3-74. "Blue" Screen LSB Control

Subaddress	62h
Default	00h

7	6	5	4	3	2	1	0
Reserved		Y value LSB [1:0]		Cb value LSB [1:0]		Cr value LSB [1:0]	

The two LSB for the "Blue" screen Y, Cb, and Cr values are represented in this register.

Table 3-75. Noise Measurement

Subaddress	64h–65h
	Read only

Subaddress	7	6	5	4	3	2	1	0
64h	3DNR Noise Measurement [7:0]							
65h	3DNR Noise Measurement [15:8]							

3DNR Noise Measurement

Because this register is a double-byte register it is necessary to capture the setting into the register to ensure that the value is not updated between reading the lower and upper bytes. To cause this register to capture the current settings, bit 0 of I²C register 97h (status request) must be set to 1b. Once the internal processor has updated this register bit 0 of register 97h is cleared, indicating that both bytes of the noise measurement register have been updated and can be read. Either byte may be read first, because no further update will occur until bit 0 of 97h is set to 1b again.

Table 3-76. 3DNR Y Core0

Subaddress	66h
	Read only

7	6	5	4	3	2	1	0
Y_core0[7:0]							

Y Core0
Table 3-77. 3DNR UV Core0

Subaddress	67h
	Read only

7	6	5	4	3	2	1	0
UV_core0[7:0]							

UV Core0

Table 3-78. F- and V-Bit Decode Control

Subaddress	69h
Default	00h

7	6	5	4	3	2	1	0
			VPLL	Adaptive	Reserved	F-Mode[1:0]	

This register only works in manual gain control mode. When AGC is active, writing to any value is ignored.

F-bit control mode

00 = Auto: If lines per frame is standard decode F and V bits as per 656 standard from line count else decode F bit from vsync input and set V bit = 0b

01 = Decode F and V bits from input syncs

10 = Reserved

11 = Always decode F and V bits from line count (TVP5146 compatible)

This register is used in conjunction with register 75h as indicated below:

REGISTER 69H		REGISTER 75H		MODE	STANDARD LPF		NONSTANDARD LPF	
BIT 1	BIT 0	BIT 3	BIT 2		F	V	F	V
0	0	0	0	Reserved	Reserved	Reserved	Reserved	Reserved
0	0	0	1	TVP5160	656	656	Toggle	Switch9
0	0	1	0	TVP5160	656	656	Pulse	0
0	0	1	1	Reserved	Reserved	Reserved	Reserved	Reserved
0	1	0	0	Reserved	Reserved	Reserved	Reserved	Reserved
0	1	0	1		656	656	Toggle	Switch9
0	1	1	0		656	656	Pulse	0
0	1	1	1	Reserved	Reserved	Reserved	Reserved	Reserved
1	0	0	0	Reserved	Reserved	Reserved	Reserved	Reserved
1	0	0	1	Reserved	Reserved	Reserved	Reserved	Reserved
1	0	1	0	Reserved	Reserved	Reserved	Reserved	Reserved
1	0	1	1	Reserved	Reserved	Reserved	Reserved	Reserved
1	1	0	0	TVP5146	656	656	Even = 1 Odd = toggle	Switch
1	1	0	1	TVP5146	656	656	Toggle	Switch
1	1	1	0	TVP5146	656	656	Pulse	Switch
1	1	1	1	Reserved	Reserved	Reserved	Reserved	Reserved

656 = ITU-R BT.656 standard

Pulse = Pulses low for 1 line prior to field transition

Switch = V bit switches high before the F-bit transition and low after the F bit transition

Switch9 = V bit switches high 1 line prior to the F-bit transition, then low after 9 lines

Reserved = Not used

Adaptive

0 = Enable F- and V-bit adaptation to detected lines per frame

1 = Disable F- and V-bit adaptation to detected lines per frame

VPLL time constant control:

0 = VPLL adapts time constants to input signal

1 = VPLL time constants fixed

Table 3-79. Back-End AGC Control

Subaddress	6Ch						
Default	08h						
7	6	5	4	3	2	1	0
Reserved				1	Peak	Color	Sync

This register allows disabling the back-end AGC when the front-end AGC uses specific amplitude references (sync height, color burst, or composite peak) to decrement the front-end gain. For example, writing 0x09 to this register disables the back-end AGC whenever the front-end AGC uses the sync height to decrement the front-end gain.

Sync: Disables back end AGC when the front end AGC uses the sync height as an amplitude reference.

0 = Enabled (default)

1 = Disabled

Color: Disables back end AGC when the front end AGC uses the color burst as an amplitude reference.

0 = Enabled (default)

1 = Disabled

Peak: Disables back end AGC when the front end AGC uses the composite peak as an amplitude reference.

0 = Enabled (default)

1 = Disabled

Table 3-80. AGC Decrement Speed

Subaddress	6Fh						
Default	04h						
7	6	5	4	3	2	1	0
Reserved					AGC decrement speed [2:0]		

AGC decrement speed: Adjusts gain decrement speed. Only used for composite/luma peaks.

111 = 7 (slowest)

110 = 6 (default)

⋮

000 = 0 (fastest)

Table 3-81. ROM Version

Subaddress	70h						
	Read only						
7	6	5	4	3	2	1	0
ROM version [7:0]							

ROM Version [7:0]: ROM revision number

Table 3-82. RAM Version MSB

Subaddress	71h						
	Read only						
7	6	5	4	3	2	1	0
RAM version MSB [7:0]							

RAM version MSB [7:0]: This register identifies the MSB of the RAM code revision number.

Table 3-83. AGC White Peak Processing

Subaddress	74h						
Default	00h						
7	6	5	4	3	2	1	0
Luma peak A	Reserved	Color burst A	Sync height A	Luma peak B	Composite peak	Color burst B	Sync height B

Luma peak A: Use of the luma peak as a video amplitude reference for the back-end feed-forward type AGC algorithm

- 0 = Enabled (default)
- 1 = Disabled

Color burst A: Use of the color burst amplitude as a video amplitude reference for the back-end

- NOTE:** Not available for SECAM, component and B/W video sources.
- 0 = Enabled (default)
 - 1 = Disabled

Sync height A: Use of the sync height as a video amplitude reference for the back-end feed-forward type AGC algorithm

- 0 = Enabled (default)
- 1 = Disabled

Luma peak B: Use of the luma peak as a video amplitude reference for front-end feedback type AGC algorithm

- 0 = Enabled (default)
- 1 = Disabled

Composite peak: Use of the composite peak as a video amplitude reference for front-end feedback type AGC algorithm

- NOTE:** Required for CVBS video sources
- 0 = Enabled (default)
 - 1 = Disabled

Color burst B: Use of the color burst amplitude as a video amplitude reference for front-end feedback type AGC algorithm

- NOTE:** Not available for SECAM, component and B/W video sources
- 0 = Enabled (default)
 - 1 = Disabled

Sync height B: Use of the sync-height as a video amplitude reference for front-end feedback type AGC algorithm

- 0 = Enabled (default)
- 1 = Disabled

NOTE: If all 4 bits of the lower nibble are set to 1111b (that is, no amplitude reference selected), then the front-end analog and digital gains are automatically set to nominal values.

If all 4 bits of the upper nibble are set to 1111b (that is, no amplitude reference selected), then the back-end gain is set automatically to unity. If the input sync height is greater than 100% and the AGC-adjusted output video amplitude becomes less than 100%, then the back-end scale factor attempts to increase the contrast in the back-end to restore the video amplitude to 100%.

Table 3-84. F-Bit and V-Bit Control

Subaddress	75h						
Default	16h						
7	6	5	4	3	2	1	0
Reserved			1	F and V [1:0]		1	Reserved

F and V [1:0]

F AND V ⁽¹⁾	LINES PER FRAME	F BIT	V BIT
00 =	Standard	ITU-R BT 656	ITU-R BT.656
	Nonstandard even	Forced to 1	Switch at field boundary
	Nonstandard odd	Toggles	Switch at field boundary
01 = (default)	Standard	ITU-R BT 656	ITU-R BT.656
	Nonstandard	Toggles	Switch at field boundary
10 =	Standard	ITU-R BT 656	ITU-R BT.656
	Nonstandard	Pulsed mode	Switch at field boundary
11 =	Reserved		

(1) F and V control bits are only enabled for F-bit control modes 01 and 10 (see register 69h).

Table 3-85. AGC Increment Speed

Subaddress	78h
Default	06h

7	6	5	4	3	2	1	0
Reserved					AGC increment speed [2:0]		

AGC increment speed: Adjusts gain increment speed.

- 111 = 7 (slowest)
- 110 = 6 (default)
- ⋮
- 000 = 0 (fastest)

Table 3-86. AGC Increment Delay

Subaddress	79h
Default	1Eh

7	6	5	4	3	2	1	0
AGC increment delay [7:0]							

AGC increment delay: Number of frames to delay gain increments

- 1111 1111 = 255
- ⋮
- 0001 1110 = 30 (default)
- ⋮
- 0000 0000 = 0

Table 3-87. Analog Output Control 1

Subaddress	7Fh
Default	00h

7	6	5	4	3	2	1	0
Reserved					AGC enable	Reserved	Analog output enable

AGC enable:

- 0 = Enabled (default)
- 1 = Disabled, manual gain mode set (see Section 4.2.10)

Analog output enable:

- 0 = Analog output is disabled (default)
- 1 = Analog output is enabled

Table 3-88. Chip ID MSB

Subaddress	80h
	Read only

7	6	5	4	3	2	1	0
CHIP ID MSB[7:0]							

CHIP ID MSB[7:0]: This register identifies the MSB of device ID. Value = 51h

Table 3-89. Chip ID LSB

Subaddress	81h
	Read only

7	6	5	4	3	2	1	0
CHIP ID LSB [7:0]							

CHIP ID LSB [7:0]: This register identifies the LSB of device ID. Value = 60h

Table 3-90. RAM Version LSB

Subaddress	82h						
	Read only						
7	6	5	4	3	2	1	0
RAM version LSB [7:0]							

RAM version LSB [7:0]: This register identifies the LSB of the RAM code revision number.

Example:

Patch Release = v04.04.02
 ROM Version = 04h
 RAM Version MSB = 04h
 RAM Version LSB = 02h

Table 3-91. Color PLL Speed Control

Subaddress	83h						
Default	09h						
7	6	5	4	3	2	1	0
Speed[3:0]							

Color PLL speed control.

Table 3-92. 3DYC Luma Coring LSB

Subaddress	84h						
Default	20h/20h						
7	6	5	4	3	2	1	0
3DYC Luma Coring [7:0]							

This register contains the lower 8 bits of the 10-bit 3DYC luma coring register. The upper 2 bits are accessed through I²C register 86h.

An inter-frame luma signal difference smaller than the programmed value is assumed to be noise, resulting in the pixel being recognized as "no motion" hence favoring intra-frame (3D) comb filtering. The minimum value of 000h favors the 2D comb filter output, whereas the maximum value of 3FFh favors the 3D comb filter output.

Table 3-93. 3DYC Chroma Coring LSB

Subaddress	85h						
Default	20h/2Ah						
7	6	5	4	3	2	1	0
3DYC Chroma Coring [7:0]							

This register contains the lower 8 bits of the 10-bit 3DYC chroma coring register. The upper 2 bits are accessed through I²C register 86h.

An inter-frame chroma signal difference smaller than the programmed value is assumed to be noise, resulting in the pixel being recognized as "no motion" hence favoring intra-frame (3D) comb filtering. The minimum value of 000h favors the 2D comb filter output whereas the maximum value of 3FFh favors the 3D comb filter output.

Table 3-94. 3DYC Luma/Chroma Coring MSB

Subaddress	86h						
Default	00h/00h						
7	6	5	4	3	2	1	0
Reserved				Chroma Coring [9:8]		Luma Coring [9:8]	

This register contains the upper 2 bits of the 10-bit 3DYC luma coring and 3DYC chroma coring registers. The lower 8 bits are accessed through I²C registers 84h and 85h.

An inter-frame luma signal difference smaller than the programmed value is assumed to be noise, resulting in the pixel being recognized as "no motion" hence favoring intra-frame (3D) comb filtering. The minimum value of 000h favors the 2D comb filter output, whereas the maximum value of 3FFh favors the 3D comb filter output.

Table 3-95. 3DYC Luma Gain

Subaddress	87h
Default	08h/08h

7	6	5	4	3	2	1	0
3DYC luma gain [7:0]							

This register contains a 5.3 format gain value used to calculate the luma difference value for luma coring. The gain can vary from 0 to 31.875 in steps of 0.125. The minimum value of 0 favors the 3D comb filter output, whereas the maximum value of 31.875 favors the 2D comb filter output.

Table 3-96. 3DYC Chroma Gain

Subaddress	88h
Default	08h/08h

7	6	5	4	3	2	1	0
3DYC chroma gain [7:0]							

This register contains a 5.3 format gain value used to calculate the chroma difference value for chroma coring. The gain can vary from 0 to 31.875 in steps of 0.125. The minimum value of 0 favors the 3D comb filter output, whereas the maximum value of 31.875 favors the 2D comb filter output.

Table 3-97. 3DYC Signal Quality Gain

Subaddress	89h
Default	02h/02h

7	6	5	4	3	2	1	0
3DYC Signal Quality gain [7:0]							

When the input signal quality is not good, for example weak broadcast signals or poor VCR signals, 3DCY comb filtering is automatically turned off. This register sets the gain, or sensitivity, to distinguish poor signal quality. A smaller value in this register favors application of 3DYC, whereas a larger value favors 2DYC.

Table 3-98. 3DYC Signal Quality Coring

Subaddress	8Ah–8Bh
Default	328h/380h

Subaddress	7	6	5	4	3	2	1	0
8Ah	3DYC Signal Quality Coring [7:0]							
8Bh	3DYC Signal Quality Coring [15:8]							

When the input signal quality is not good, for example weak broadcast signals or poor VCR signals, 3DCY comb filtering is automatically turned off. This register sets the coring value used to distinguish poor signal quality. A larger value in this register favors application of 3DYC, whereas a smaller value favors 2DYC.

Table 3-99. IF Compensation Control

Subaddress	8Dh
Default	00h

7	6	5	4	3	2	1	0
Reserved				U	V	Comp.	IF Enable

Comp:

0 = Crosstalk compensation only. Use if SAW IF stage used.

1 = Crosstalk and low-frequency gain compensation. Use if non-SAW IF stage used.

U: Enable high frequency U gain

0 = Enabled

1 = Disabled

V: Enable high frequency V gain

0 = Enabled

1 = Disabled

IF enable:

0 = IF compensation disabled (default)

1 = IF compensation enabled

Table 3-100. IF Differential Gain Control

Subaddress	8Eh
Default	22h

7	6	5	4	3	2	1	0
U differential gain[3:0]				V differential gain[3:0]			

For low IF stage distortions, use lower settings.

Table 3-101. IF Low Frequency Gain Control

Subaddress	8Fh
Default	44h

7	6	5	4	3	2	1	0
U low frequency gain[3:0]				V low frequency gain[3:0]			

Table 3-102. IF High Frequency Gain Control

Subaddress	90h
Default	00h

7	6	5	4	3	2	1	0
U high frequency gain[3:0]				V high frequency gain[3:0]			

Table 3-103. Weak Signal High Threshold

Subaddress	95h
Default	60h

7	6	5	4	3	2	1	0
Level [7:0]							

This register controls the upper threshold of the noise measurement that determines whether the input signal is considered a weak signal.

Table 3-104. Weak Signal High Threshold

Subaddress	96h						
Default	50h						
7	6	5	4	3	2	1	0
Level [7:0]							

This register controls the lower threshold of the noise measurement that determines whether the input signal is considered a weak signal.

Table 3-105. Status Request

Subaddress	97h						
Default	00h						
7	6	5	4	3	2	1	0
Reserved							Capture

Capture:

Setting a 1b in this bit causes the internal processor to capture the current settings of the AGC status, 3DNR noise measurement, and the vertical line count registers. Because this capture is not immediate, it is necessary to check for completion of the capture by reading the Capture bit repeatedly after setting it and waiting for it to be cleared by the internal processor. Once the Capture bit is 0b, then the AGC status, noise measurement, and vertical line counters (3Ch/3Dh, 64h/65h, and 9Ah/9Bh) will have been updated and can be safely read in any order.

Table 3-106. 3DYC NTSC VCR Threshold

Subaddress	98h						
Default	10h						
7	6	5	4	3	2	1	0
Thresh [7:0]							

This register controls how 3DYC is enabled/disabled for VCR modes.

Table 3-107. 3DYC PAL VCR Threshold

Subaddress	99h						
Default	20h						
7	6	5	4	3	2	1	0
Thresh [7:0]							

This register controls how 3DYC is enabled/disabled for VCR modes.

Table 3-108. Vertical Line Count

Subaddress	9Ah–9Bh							
	Read only							
Subaddress	7	6	5	4	3	2	1	0
9Ah	Vertical line [7:0]							
9Bh	Reserved						Vertical line [9:8]	

Vertical line [9:0] represent the detected a total number of lines from the previous frame. This can be used with nonstandard video signals such as a VCR in trick mode to synchronize downstream video circuitry.

Because this register is a double-byte register it is necessary to capture the setting into the register to ensure that the value is not updated between reading the lower and upper bytes. To cause this register to capture the current settings bit 0 of 1²C register 97h (status request) must be set to a 1b. Once the internal processor has updated this register, bit 0 of register 97h is cleared, indicating that both bytes of the vertical line count register have been updated and can be read. Either byte may be read first, because no further update will occur until bit 0 of 97h is set to 1b again.

Table 3-109. AGC Decrement Delay

Subaddress	9Eh
Default	1Eh

7	6	5	4	3	2	1	0
AGC decrement delay [7:0]							

AGC decrement delay: Number of frames to delay gain decrements

1111 1111 = 255

0001 1110 = 30 (default)

0000 0000 = 0

Table 3-110. VDP TTX Filter and Mask

Subaddress	B1h	B2h	B3h	B4h	B5h	B6h	B7h	B8h	B9h	BAh
Default	00h	00h	00h	00h	00h	00h	00h	00h	00h	00h

Subaddress	7	6	5	4	3	2	1	0
B1h	Filter 1 Mask 1				Filter 1 Pattern 1			
B2h	Filter 1 Mask 2				Filter 1 Pattern 2			
B3h	Filter 1 Mask 3				Filter 1 Pattern 3			
B4h	Filter 1 Mask 4				Filter 1 Pattern 4			
B5h	Filter 1 Mask 5				Filter 1 Pattern 5			
B6h	Filter 2 Mask 1				Filter 2 Pattern 1			
B7h	Filter 2 Mask 2				Filter 2 Pattern 2			
B8h	Filter 2 Mask 3				Filter 2 Pattern 3			
B9h	Filter 2 Mask 4				Filter 2 Pattern 4			
BAh	Filter 2 Mask 5				Filter 2 Pattern 5			

For an NABTS system, the packet prefix consists of five bytes. Each byte contains 4 data bits (D[3:0]) interlaced with 4 Hamming protection bits (H[3:0]):

Bit 7	Bit 6	Bit 5	Bit 4	Bit 3	Bit 2	Bit 1	Bit 0
D[3]	H[3]	D[2]	H[2]	D[1]	H[1]	D[0]	H[0]

Only the data portion D[3:0] from each byte is applied to a teletext filter function with corresponding pattern bits P[3:0] and mask bits M[3:0]. The filter ignores hamming protection bits.

For a WST system (PAL or NTSC), the packet prefix consists of two bytes. The two bytes contain three bits of magazine number (M[2:0]) and five bits of row address (R[4:0]), interlaced with eight Hamming protection bits H[7:0]:

Bit 7	Bit 6	Bit 5	Bit 4	Bit 3	Bit 2	Bit 1	Bit 0
R[0]	H[3]	M[2]	H[2]	M[1]	H[1]	M[0]	H[0]
R[4]	H[7]	R[3]	H[6]	R[2]	H[5]	R[1]	H[4]

The mask bits enable filtering using the corresponding bit in the pattern register. For example, a 1b in the LSB of mask 1 means that the filter module should compare the LSB of nibble 1 in the pattern register to the first data bit on the transaction. If these match, then a true result is returned. A 0b in a mask bit means that the filter module should ignore that data bit of the transaction. If all 0s are programmed in the mask bits, the filter matches all patterns returning a true result (default 00h).

Table 3-111. VDP TTX Filter Control

Subaddress	BBh
Default	00h

7	6	5	4	3	2	1	0
Reserved			Filter logic [1:0]		Mode	TTX filter 2 enable	TTX filter 1 enable

Filter logic [1:0]: Allow different logic to be applied when combining the decision of Filter 1 and Filter 2 as follows:

- 00 = NOR (default)
- 01 = NAND
- 10 = OR
- 11 = AND

Mode: Indicates which teletext mode is in use:

- 0 = Teletext filter applies to 2 header bytes (default)
- 1 = Teletext filter applies to 5 header bytes

TTX filter 2 enable: provides for enabling the teletext filter function within the VDP.

- 0 = Disable (default)
- 1 = Enable

TTX filter 1 enable: provides for enabling the teletext filter function within the VDP.

- 0 = Disable (default)
- 1 = Enable

If the filter matches or if the filter mask is all 0s, then a true result is returned.

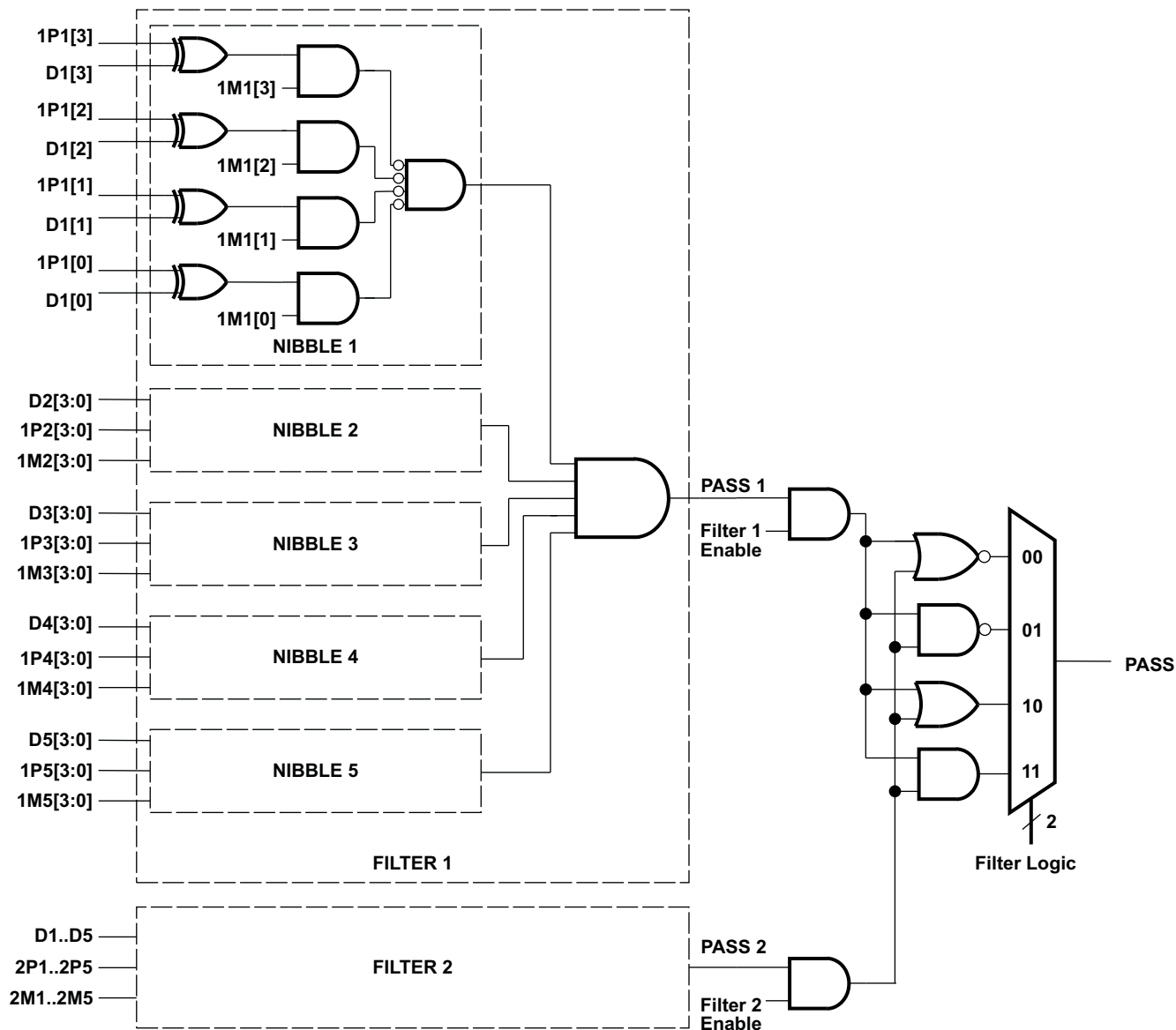

Figure 3-1. Teletext Filter Function

Table 3-112. VDP FIFO Word Count

Subaddress	BCh									
	Read only	7	6	5	4	3	2	1	0	
		FIFO word count [7:0]								

FIFO word count [7:0]: This register provides the number of words in the FIFO.

Note: 1 word equals 2 bytes.

Table 3-113. VDP FIFO Interrupt Threshold

Subaddress	BDh						
Default	80h						
7	6	5	4	3	2	1	0
Thresh [7:0]							

Threshold [7:0]: This register is programmed to trigger an interrupt when the number of words in the FIFO exceeds this value.

Note: 1 word equals 2 bytes.

Table 3-114. VDP FIFO Reset

Subaddress	BFh						
Default	00h						
7	6	5	4	3	2	1	0
Reserved							FIFO reset

FIFO reset: Writing any data to this register clears the FIFO and VDP data registers. After clearing, this register bit is automatically cleared.

Table 3-115. VDP FIFO Output Control

Subaddress	C0h						
Default	00h						
7	6	5	4	3	2	1	0
Reserved							Host access enable

Host access enable: This register is programmed to allow the host port access to the FIFO or allowing all VDP data to go out the video output.

0 = Output FIFO data to the video output Y[9:2] (default)

1 = Allow host port access to the FIFO data

Table 3-116. VDP Line Number Interrupt

Subaddress	C1h						
Default	00h						
7	6	5	4	3	2	1	0
Field 1 enable	Field 2 enable	Line number [5:0]					

Field 1 interrupt enable:

0 = Disabled (default)

1 = Enabled

Field 2 interrupt enable:

0 = Disabled (default)

1 = Enabled

Line number [5:0]: Interrupt line number (default 00h)

This register is programmed to trigger an interrupt when the video line number exceeds this value in bits [5:0]. This interrupt must be enabled at address F4h.

Note: The line number value of zero or one is invalid and will not generate an interrupt.

Table 3-117. VDP Pixel Alignment

Subaddress	C2h–C3h							
Default	01Eh							
Subaddress	7	6	5	4	3	2	1	0
C2h	Pixel alignment [7:0]							
C3h	Reserved						Pixel alignment [9:0]	

Pixel alignment [9:0]: These registers form a 10-bit horizontal pixel position from the falling edge of horizontal sync, where the VDP controller will initiate the program from one line standard to the next line standard. For example, the previous line of teletext to the next line of closed caption. This value must be set so that the switch occurs after the previous transaction has cleared the delay in the VDP, but early enough to allow the new values to be programmed before the current settings are required.

The default value is 0x1E and has been tested with every standard supported here. A new value will only be needed if a custom standard is in use.

Table 3-118. VDP Line Start

Subaddress	D6h							
Default	06h							
	7	6	5	4	3	2	1	0
VDP line start [7:0]								

VDP line start [7:0]: Sets the VDP line starting address for the global line mode register

This register has to be set properly before enabling the line mode registers. The global line mode is only active in the region defined by the VDP line start and stop registers.

Table 3-119. VDP Line Stop

Subaddress	D7h							
Default	1Bh							
	7	6	5	4	3	2	1	0
VDP line stop [7:0]								

VDP line stop address [7:0]: Sets the VDP stop line.

Table 3-120. VDP Global Line Mode

Subaddress	D8h							
Default	FFh							
	7	6	5	4	3	2	1	0
Global line mode [7:0]								

Global line mode [7:0]: VDP processing for multiple lines set by VDP start line register D6h and stop line register D7h.

Global line mode register has the same bits definitions as the line mode register's (see [Table 3-143](#)).

General line mode will have priority over the global line mode.

Table 3-121. VDP Full Field Enable

Subaddress	D9h							
Default	00h							
	7	6	5	4	3	2	1	0
Reserved								Full field enable

Full field enable:

0 = Disabled full field mode(default)

1 = Enabled full field mode

This register enables the full field mode. In this mode, all lines outside the vertical blank area and all lines in the line mode register programmed with FFh are sliced with the definition of full field mode register at subaddress DAh. Values other than FFh in the line mode registers allow a different slice mode for that particular line.

Table 3-122. VDP Full Field Mode

Subaddress	DAh
Default	FFh

7	6	5	4	3	2	1	0
Full field mode [7:0]							

Full field mode [7:0]: This register programs the specific VBI standard for full field mode. It can be any VBI standard. Individual line settings take priority over the full field register. This allows each VBI line to be programmed independently but have the remaining lines in full field mode. The full field mode register has the same bits definition as line mode registers. (default FFh)

Global line mode will have priority over the full field mode.

Table 3-123. Interlaced/Progressive Status

Subaddress	DBh
	Read only

7	6	5	4	3	2	1	0
							I/P

Interlaced/progressive detection status:

0 = SD interlaced signal detected

1 = ED/HD signal detected

Table 3-124. VBUS Data Access with No VBUS Address Increment

Subaddress	E0h
Default	00h

7	6	5	4	3	2	1	0
VBUS data [7:0]							

VBUS data [7:0]: VBUS data register for VBUS single byte read/write transaction.

Table 3-125. VBUS Data Access with VBUS Address Increment

Subaddress	E1h
Default	00h

7	6	5	4	3	2	1	0
VBUS data [7:0]							

VBUS data [7:0]: VBUS data register for VBUS multi-byte read/write transaction. VBUS address is auto-incremented after each data byte read/write.

Table 3-126. VDP FIFO Read Data

Subaddress	E2h
	Read only

7	6	5	4	3	2	1	0
FIFO Read Data [7:0]							

FIFO Read Data [7:0]: This register is provided to access VBI FIFO data through the I²C interface. All forms of teletext data come directly from the FIFO, while all other forms of VBI data can be programmed to come from registers or from the FIFO. If the host port reads data from the FIFO, then bit 0 (host access enable) in the VDP FIFO output control register at subaddress C0h must be set to 1b.

Table 3-127. VBUS Address

Subaddress	E8h	E9h	EAh					
Default	00h	00h	00h					
Subaddress	7	6	5	4	3	2	1	0
E8h	VBUS address [7:0]							
E9h	VBUS address [15:8]							
EAh	VBUS address [23:16]							

VBUS address [23:0]: VBUS is a 24-bit wide internal bus. The user must program the 24-bit address of the internal register to be accessed via host port indirect access mode.

Table 3-128. Interrupt Raw Status 0

Subaddress	F0h						
	Read only						
7	6	5	4	3	2	1	0
FIFO THRS	TTX	WSS/CGMS	VPS/Gemstar	VITC	CC F2	CC F1	Line

FIFO THRS: FIFO threshold passed, unmasked

- 0 = Not passed
- 1 = Passed

TTX: Teletext data available unmasked

- 0 = Not available
- 1 = Available

WSS/CGMS: WSS/CGMS data available unmasked

- 0 = Not available
- 1 = Available

VPS/Gemstar: VPS/Gemstar data available unmasked

- 0 = Not available
- 1 = Available

VITC: VITC data available unmasked

- 0 = Not available
- 1 = Available

CC F2: CC field 2 data available unmasked

- 0 = Not available
- 1 = Available

CC F1: CC field 1 data available unmasked

- 0 = Not available
- 1 = Available

Line: Line number interrupt unmasked

- 0 = Not available
- 1 = Available

The host interrupt raw status 0 and 1 registers represent the interrupt status without applying mask bits.

Table 3-129. Interrupt Raw Status 1

Subaddress	F1h						
	Read only						
7	6	5	4	3	2	1	0
Reserved							FIFO full

FIFO full:

0 = FIFO not full

1 = FIFO was full during write to FIFO

The masked or unmasked status is set in the interrupt mask 1 register at subaddress F5h.

The FIFO full error flag is set when the current line of VBI data can not enter the FIFO. For example, if the FIFO has only 10 bytes left and teletext is the current VBI line, the FIFO full error flag is set, but no data will be written because the entire teletext line will not fit. However, if the next VBI line is closed caption requiring only 2 bytes of data plus the header, then this will go into the FIFO even if the full error flag is set.

Table 3-130. Interrupt Status 0

Subaddress	F2h						
	Read only						
7	6	5	4	3	2	1	0
FIFO THRS	TTX	WSS/CGMS	VPS/Gemstar	VITC	CC F2	CC F1	Line

FIFO THRS: FIFO threshold passed, masked

0 = Not passed

1 = Passed

TTX: Teletext data available masked

0 = Not available

1 = Available

WSS/CGMS: WSS/CGMS data available masked

0 = Not available

1 = Available

VPS/Gemstar: VPS/Gemstar data available masked

0 = Not available

1 = Available

VITC: VITC data available masked

0 = Not available

1 = Available

CC F2: CC field 2 data available masked

0 = Not available

1 = Available

CC F1: CC field 1 data available masked

0 = Not available

1 = Available

Line: Line number interrupt masked

0 = Not available

1 = Available

The interrupt status 0 and 1 registers represent the interrupt status after applying mask bits. Therefore, the status bits are the result of a logical AND between the raw status and mask bits. The external interrupt pin is derived from this register as an OR function of all nonmasked interrupts in this register.

Reading data from the corresponding register does not clear the status flags automatically. These flags are reset using the corresponding bits in interrupt clear 0 and 1 registers.

Table 3-131. Interrupt Status 1

Subaddress	F3h						
	Read only						
7	6	5	4	3	2	1	0
Reserved							FIFO full

FIFO full: Masked status of FIFO

0 = FIFO not full

1 = FIFO was full during write to FIFO, see the interrupt mask 1 register at subaddress F5h

The masked or unmasked status is set in the interrupt mask 1 register.

Table 3-132. Interrupt Mask 0

Subaddress	F4h						
	Read only						
7	6	5	4	3	2	1	0
FIFO THRS	TTX	WSS/CGMS	VPS/Gemstar	VITC	CC F2	CC F1	Line

FIFO THRS: FIFO threshold passed mask

0 = Disabled (default)

1 = Enabled FIFO_THRES interrupt

TTX: Teletext data available mask

0 = Disabled (default)

1 = Enabled TTX available interrupt

WSS/CGMS: WSS/CGMS data available mask

0 = Disabled (default)

1 = Enabled WSS/CGMS available interrupt

VPS/Gemstar: VPS/Gemstar data available mask:

0 = Disabled (default)

1 = Enabled VPS/Gemstar available interrupt

VITC: VITC data available mask:

0 = Disabled (default)

1 = Enabled VITC available interrupt

CC F2: CC field 2 data available mask

0 = Disabled (default)

1 = Enabled CC field 2 available interrupt

CC F1: CC field 1 data available mask

0 = Disabled (default)

1 = Enabled CC field 1 available interrupt

LINE: Line number interrupt mask

0 = Disabled (default)

1 = Enabled Line_INT interrupt

The host interrupt mask 0 and 1 registers can be used by the external processor to mask unnecessary interrupt sources for interrupt status 0 and 1 register bits, and for the external interrupt pin. The external interrupt is generated from all nonmasked interrupt flags.

Table 3-133. Interrupt Mask 1

Subaddress	F5h						
	Read only						
7	6	5	4	3	2	1	0
Reserved							FIFO full

FIFO full: FIFO full mask

0 = Disabled (default)

1 = Enabled FIFO full interrupt

Table 3-134. Interrupt Clear 0

Subaddress	F6h						
	Read only						
7	6	5	4	3	2	1	0
FIFO THRS	TTX	WSS/CGMS	VPS/Gemstar	VITC	CC F2	CC F1	Line

FIFO THRS: FIFO threshold passed clear

0 = No effect (default)

1 = Clear FIFO_THRES bit in status register 0 bit 7

TTX: Teletext data available clear

0 = No effect (default)

1 = Clear TTX available bit in status register 0 bit 6

WSS/CGMS: WSS/CGMS data available clear

0 = No effect (default)

1 = Clear WSS/CGMS available bit in status register 0 bit 5

VPS/Gemstar: VPS/Gemstar data available clear

0 = No effect (default)

1 = Clear VPS/Gemstar available bit in status register 0 bit 4

VITC: VITC data available clear

0 = Disabled (default)

1 = Clear VITC available bit in status register 0 bit 3

CC F2: CC field 2 data available clear

0 = Disabled (default)

1 = Clear CC field 2 available bit in status register 0 bit 2

CC F1: CC field 1 data available clear

0 = Disabled (default)

1 = Clear CC field 1 available bit in status register 0 bit 1

LINE: Line number interrupt clear

0 = Disabled (default)

1 = Clear Line interrupt available bit in status register 0 bit 0

The host interrupt clear 0 and 1 registers are used by the external processor to clear the interrupt status bits in the host interrupt status 0 and 1 registers. When no nonmasked interrupts remain set in the registers, the external interrupt pin will also become inactive.

Table 3-135. Interrupt Clear 1

Subaddress	F7h						
	Read only						
7	6	5	4	3	2	1	0
Reserved							FIFO full

FIFO full: Clear FIFO full flag

0 = No effect (default)

1 = Clear bit 0 (FIFO full flag) in the interrupt status 1 register at subaddress F3h and the interrupt raw status 1 register at subaddress F1h

3.2 VBUS Register Definitions

Table 3-136. VDP Closed Caption Data

Subaddress	80 051Ch – 80 051Fh							
	Read only							
Subaddress	7	6	5	4	3	2	1	0
80 051Ch	Closed Caption Field 1 byte 1							
80 051Dh	Closed Caption Field 1 byte 2							
80 051Eh	Closed Caption Field 2 byte 1							
80 051Fh	Closed Caption Field 2 byte 2							

These registers contain the closed caption data arranged in bytes per field.

Table 3-137. VDP WSS/CGMS Data

Subaddress	80 0520h – 80 0526h
	Read only

WSS/CGMS NTSC

Subaddress	7	6	5	4	3	2	1	0	Byte
80 0520h	–	–	b5	b4	b3	b2	b1	b0	WSS/CGMS Field 1 Byte 1
80 0521h	b13	b12	b11	b10	b9	b8	b7	b6	WSS/CGMS Field 1 Byte 2
80 0522h	–	–	b19	b18	b17	b16	b15	b14	WSS/CGMS Field 1 Byte 3
80 0523h	Reserved								
80 0524h	–	–	b5	b4	b3	b2	b1	b0	WSS/CGMS Field 2 Byte 1
80 0525h	b13	b12	b11	b10	b9	b8	b7	b6	WSS/CGMS Field 2 Byte 2
80 0526h	–	–	b19	b18	b17	b16	b15	b14	WSS/CGMS Field 2 Byte 3

These registers contain the wide screen signaling data for NTSC.

Bits 0 – 1 represent word 0, aspect ratio

Bits 2 – 5 represent word 1, header code for word 2

Bits 6 – 13 represent word 2, copy control

Bits 14 – 19 represent word 3, CRC

WSS/CGMS PAL/SECAM

Subaddress	7	6	5	4	3	2	1	0	Byte
80 0520h	b7	b6	b5	b4	b3	b2	b1	b0	WSS/CGMS Field 1 Byte 1
80 0521h	–	–	b13	b12	b11	b10	b9	b8	WSS/CGMS Field 1 Byte 2
80 0522h	Reserved								
80 0523h	Reserved								
80 0524h	b7	b6	b5	b4	b3	b2	b1	b0	WSS/CGMS Field 2 Byte 1
80 0525h	–	–	b13	b12	b11	b10	b9	b8	WSS/CGMS Field 2 Byte 2
80 0526h	Reserved								

These registers contain the wide screen signaling data for PAL/SECAM:

Bits 0 – 3 represent Group 1, Aspect Ratio

Bits 4 – 7 represent Group 2, Enhanced Services

Bits 8 – 10 represent Group 3, Subtitles

Bits 11 – 13 represent Group 4, Others

Table 3-138. VDP VITC Data

Subaddress	80 052Ch – 80 0534h							
	Read only							
Subaddress	7	6	5	4	3	2	1	0
80 052Ch	VITC frame byte 1							
80 052Dh	VITC frame byte 2							
80 052Eh	VITC seconds byte 1							
80 052Fh	VITC seconds byte 2							
80 0530h	VITC minutes byte 1							
80 0531h	VITC minutes byte 2							
80 0532h	VITC hours byte 1							
80 0533h	VITC hours byte 2							
80 0534h	VITC CRC byte							

These registers contain the VITC data.

Table 3-139. VDP V-Chip TV Rating Block 1

Subaddress	80 0540h						
	Read only						
7	6	5	4	3	2	1	0
Reserved	14-D	PG-D	Reserved	MA-L	14-L	PG-L	Reserved

TV Parental Guidelines Rating Block 3

- 14-D: When incoming video program is TV-14-D rated, this bit is set high.
- PG-D: When incoming video program is TV-PG-D rated, this bit is set high.
- MA-L: When incoming video program is TV-MA-L rated, this bit is set high.
- 14-L: When incoming video program is TV-14-L rated, this bit is set high.
- PG-L: When incoming video program is TV-PG-L rated, this bit is set high.

Table 3-140. VDP V-Chip TV Rating Block 2

Subaddress	80 0541h						
	Read only						
7	6	5	4	3	2	1	0
Reserved	14-S	PG-S	Reserved	MA-V	14-V	PG-V	Y7-FV

TV Parental Guidelines Rating Block 2

- MA-S: When incoming video program is TV-MA-S rated, this bit is set high.
- 14-S: When incoming video program is TV-14-S rated, this bit is set high.
- PG-S: When incoming video program is TV-PG-S rated, this bit is set high.
- MA-V: When incoming video program is TV-MA-V rated, this bit is set high.
- 14-V: When incoming video program is TV-14-V rated, this bit is set high.
- PG-V: When incoming video program is TV-PG-S rated, this bit is set high.
- Y7-FV: When incoming video program is TV-Y7-FV rated, this bit is set high.

Table 3-141. VDP V-Chip TV Rating Block 3

Subaddress	80 0542h						
	Read only						
7	6	5	4	3	2	1	0
None	TV-MA	TV-14	TV-PG	TV-G	TV-Y7	TV-Y	None

TV Parental Guidelines Rating Block 1

None: No block intended

TV-MA: When incoming video program is "TV-MA" rated in TV Parental Guidelines Rating, this bit is set high.

TV-14: When incoming video program is "TV-14" rated in TV Parental Guidelines Rating, this bit is set high.

TV-PG: When incoming video program is "TV-PG" rated in TV Parental Guidelines Rating, this bit is set high.

TV-G: When incoming video program is "TV-G" rated in TV Parental Guidelines Rating, this bit is set high.

TV-Y7: When incoming video program is "TV-Y7" rated in TV Parental Guidelines Rating, this bit is set high.

TV-Y: When incoming video program is "TV-G" rated in TV Parental Guidelines Rating, this bit is set high.

Table 3-142. VDP V-Chip MPAA Rating Data

Subaddress	80 0543h						
	Read only						
7	6	5	4	3	2	1	0
Not Rated	X	NC-17	R	PG-13	PG	G	NA

MPAA Rating Block (E5h)

Not Rated: When incoming video program is "Not Rated" rated in MPAA Rating, this bit is set high.

X: When incoming video program is "X" rated in MPAA Rating, this bit is set high.

NC-17: When incoming video program is "NC-17" rated in MPAA Rating, this bit is set high.

R: When incoming video program is "R" rated in MPAA Rating, this bit is set high.

PG-13: When incoming video program is "PG-13" rated in MPAA Rating, this bit is set high.

PG: When incoming video program is "PG" rated in MPAA Rating, this bit is set high.

G: When incoming video program is "G" rated in MPAA Rating, this bit is set high.

N/A: When incoming video program is "N/A" rated in MPAA Rating, this bit is set high.

Table 3-143. VDP General Line Mode and Line Address

Subaddress	7	6	5	4	3	2	1	0
80 0600h								Line address 1
80 0601h								Line mode 1
80 0602h								Line address 2
80 0603h								Line mode 2
80 0604h								Line address 3
80 0605h								Line mode 3
80 0606h								Line address 4
80 0607h								Line mode 4
80 0608h								Line address 5
80 0609h								Line mode 5
80 060Ah								Line address 6
80 060Bh								Line mode 6
80 060Ch								Line address 7
80 060Dh								Line mode 7
80 060Eh								Line address 8
80 060Fh								Line mode 8
80 0610h								Line address 9
80 0611h								Line mode 9

Line address [7:0]: Line number to process selected line mode register on

Line mode register x [7:0]

Bit 7

- 0 = Disabled filters
- 1 = Enabled filters for teletext and CC (Null byte filter) (default)

Bit 6

- 0 = Send sliced VBI data to registers only
- 1 = Send sliced VBI data to FIFO and registers, teletext data only goes to FIFO (default)

Bit 5

- 0 = Allow VBI data with errors in the FIFO
- 1 = Do not allow VBI data with errors in the FIFO (default)

Bit 4

- 0 = Disabled error detection and correction
- 1 = Enabled error detection and correction (teletext only) (default)

Bit 3

- 0 = Field 1
- 1 = Field 2 (default)

Bit [2:0]

- 000 = Teletext (WST625, Chinese Teletext, NABTS 525)
- 001 = CC (US, European, Japan, China)
- 010 = WSS/CGMS (525, 625)
- 011 = VITC
- 100 = VPS (PAL only), Gemstar EPG (NTSC only)
- 101 = USER 1
- 110 = USER 2
- 111 = Reserved (active video) (default)

Table 3-144. VDP VPS, Gemstar EPG Data

Subaddress	80 0700h – 80 070Ch
	Read only

VPS

Subaddress	7	6	5	4	3	2	1	0
80 0700h	VPS byte 1							
80 0701h	VPS byte 2							
80 0702h	VPS byte 3							
80 0703h	VPS byte 4							
80 0704h	VPS byte 5							
80 0705h	VPS byte 6							
80 0706h	VPS byte 7							
80 0707h	VPS byte 8							
80 0708h	VPS byte 9							
80 0709h	VPS byte 10							
80 070Ah	VPS byte 11							
80 070Bh	VPS byte 12							
80 070Ch	VPS byte 13							

These registers contain the entire VPS data line except the clock run-in code and the frame code.

Gemstar EPG

Subaddress	7	6	5	4	3	2	1	0
80 0700h	Gemstar EPG Frame Code							
80 0701h	Gemstar EPG byte 1							
80 0702h	Gemstar EPG byte 2							
80 0703h	Gemstar EPG byte 3							
80 0704h	Gemstar EPG byte 4							
80 0705h	Reserved							
80 0706h	Reserved							
80 0707h	Reserved							
80 0708h	Reserved							
80 0709h	Reserved							
80 070Ah	Reserved							
80 070Bh	Reserved							
80 070Ch	Reserved							

Table 3-145. Analog Output Control 2

Subaddress	A0 005Eh						
Default	B2h						
7	6	5	4	3	2	1	0
Reserved				Gain[3:0]			

Analog output PGA gain [3:0]: These bits are effective when analog output AGC is disabled.

Gain[3:0]	
0000	1.30
0001	1.56
0010 (default)	1.82
0011	2.08
0100	2.34
0101	2.60
0110	2.86
0111	3.12
1000	3.38
1001	3.64
1010	3.90
1011	4.16
1100	4.42
1101	4.68
1110	4.94
1111	5.20

Table 3-146. Interrupt Configuration

Subaddress	A0 0060h						
Default	00h						
7	6	5	4	3	2	1	0
Reserved					Polarity	Reserved	

Polarity: Interrupt pin polarity

0 = Active high (default)

1 = Active low (open drain, a pullup register is required)

Table 3-147. Interrupt Raw Status 1

Subaddress	B0 0069h						
	Read only						
7	6	5	4	3	2	1	0
Reserved				H/V lock	Macrovision status changed	Standard changed	Reserved

H/V lock: unmasked

0 = H/V lock status unchanged

1 = H/V lock status changed

Macrovision status changed: unmasked

0 = Macrovision status unchanged

1 = Macrovision status changed

Standard changed: unmasked

0 = Video standard unchanged

1 = Video standard changed

The masked or unmasked status is set in the interrupt mask 1 register.

Table 3-148. Interrupt Status 1

Subaddress	B0 006Dh
	Read only

7	6	5	4	3	2	1	0
Reserved				H/V lock	Macrovision status changed	Standard changed	Reserved

H/V lock: H/V lock status changed masked

0 = H/V lock status unchanged

1 = H/V lock status changed

Macrovision status changed: Macrovision status changed masked

0 = Macrovision status not changed

1 = Macrovision status changed

Standard changed: Standard changed masked

0 = Video standard not changed

1 = Video standard changed

The masked or unmasked status is set in the interrupt mask1 register.

Table 3-149. Interrupt Mask 1

Subaddress	B0 0065h
Default	00h

7	6	5	4	3	2	1	0
Reserved				H/V lock	Macrovision status changed	Standard changed	Reserved

H/V lock: H/V lock status changed mask

0 = H/V lock status unchanged (default)

1 = H/V lock status changed

Macrovision status changed: Macrovision status changed mask

0 = Macrovision status unchanged (default)

1 = Macrovision status changed

Standard changed: Standard changed mask

0 = Disabled (default)

1 = Enabled video standard changed

Table 3-150. Interrupt Clear 1

Subaddress	B0 0071h
Default	00h

7	6	5	4	3	2	1	0
Reserved				H/V lock	Macrovision status changed	Standard changed	Reserved

H/V lock: Clear H/V lock status changed flag

0 = H/V lock status unchanged

1 = H/V lock status changed

Macrovision status changed: Clear Macrovision status changed flag

0 = No effect (default)

1 = Clear bit 2 (Macrovision status changed) in the interrupt status 1 register at subaddress B0 006Dh and the interrupt raw status 1 register at subaddress B0 0069h

Standard changed: Clear standard changed flag

0 = No effect (default)

1 = Clear bit 1 (video standard changed) in the interrupt status 1 register at subaddress B0 006Dh and the interrupt raw status 1 register at subaddress B0 0069h

5 Typical Register Programming Sequence

```

Composite Input, Autoswitch, 10-bit ITU-656, 3DYC and 3DNR Enabled
// Address, Data
0xEE, 0x01 // ROM Initialization Procedure - Required
0xEA, 0xB0
0xE9, 0x00
0xE8, 0x63
0xE0, 0x01
0xEE, 0x00
0x00, 0x00 // Input/Output Select - Composite input selected (default)
0x06, 0x40 // Luminance Processing Control 1 - No pedestal present
0x33, 0x40 // Output Formatter Control 1 - 10-bit ITU-656 (default)
0x34, 0x11 // Output Formatter Control 2 - Data and SCLK enabled
0x35, 0x2A // Output Formatter Control 3 - GPIO (pin 82) = 0, GLCO, AVID, and FID enabled
0x36, 0xAF // Output Formatter Control 4 - HS and VS enabled
0x59, 0x07 // SDRAM Control - 64-Mbit SDRAM configured and enabled; must be set before enabling
3DYC
or 3DNR
0x0D, 0x84 // Chrominance Processing Control 1 - 3DYC and 3DNR enabled
480p Progressive Inputs, Autoswitch, 20-bit ITU-656, 3DYC and 3DNR Enabled
// Address, Data
0xEE, 0x01 // ROM Initialization Procedure - Required
0xEA, 0xB0
0xE9, 0x00
0xE8, 0x63
0xE0, 0x01
0xEE, 0x00
0x00, 0x95 // Input/Output Select - Y(VI_5), Pb(VI_11), Pr(VI_8)
0x06, 0x40 // Luminance Processing Control 1 - No pedestal present
0x30, 0x0F // Component Autoswitch Mask - 480i/p and 576i/p enabled in autoswitch
0x33, 0x44 // Output Formatter Control 1 - 20-bit ITU-656
0x34, 0x11 // Output Formatter Control 2 - Data and SCLK enabled
0x35, 0x2A // Output Formatter Control 3 - GPIO (pin 82) = 0, GLCO, AVID, and FID are enabled
0x36, 0xAF // Output Formatter Control 4 - HS and VS enabled
0x59, 0x07 // SDRAM Control - 64-Mbit SDRAM configured and enabled; must be set before enabling
3DYC
or 3DNR
0x0D, 0x84 // Chrominance Processing Control 1 - 3DYC and 3DNR enabled

```

6 Electrical Specifications

6.1 Absolute Maximum Ratings

over operating free-air temperature range (unless otherwise noted) ⁽¹⁾

		MIN	MAX	UNIT
IOVDD to IOGND	Supply voltage range	0.5	4.0	V
DVDD to DGND		−0.2	2.0	V
A33VDD ⁽²⁾ to A33GND ⁽³⁾		−0.3	3.6	V
A18VDD ⁽⁴⁾ to A18GND ⁽⁵⁾		−0.2	2.0	V
V _I to DGND	Digital input voltage range	−0.5	4.5	V
V _O to DGND	Digital output voltage range	−0.5	4.5	V
A _{IN} to AGND	Analog input voltage range	−0.2	2.0	V
T _A	Operating free-air temperature	0	70	°C
T _{stg}	Storage temperature	−65	150	°C

(1) Stresses beyond those listed under "Absolute Maximum Ratings" may cause permanent damage to the device. These are stress ratings only and functional operation of the device at these or any other conditions beyond those indicated under "recommended operating conditions" is not implied. Exposure to absolute-maximum-rated conditions for extended periods may affect device reliability.

(2) CH1_A33VDD, CH2_A33VDD

(3) CH1_A33GND, CH2_A33GND

(4) CH1_A18VDD, CH2_A18VDD, A18VDD, A18VDD_REF, PLL_A18VDD

(5) CH1_A18GND, CH2_A18GND, A18GND

6.2 Recommended Operating Conditions

PARAMETER		TEST CONDITIONS	MIN	NOM	MAX	UNIT
IOVDD	Supply voltage, digital		3.0	3.3	3.6	V
DVDD	Supply voltage, digital		1.65	1.8	1.95	V
AV _{DD33}	Supply voltage, analog		3.0	3.3	3.6	V
AV _{DD18}	Supply voltage, analog		1.65	1.8	1.95	V
V _{I(PP)}	Input voltage, analog (ac-coupling necessary)		0.5	1.0	2.0	V
V _{IH}	Input voltage high, digital ⁽¹⁾		0.7 IOVDD			V
V _{IL}	Input voltage low, digital ⁽²⁾				0.3 IOVDD	V
I _{OH}	Output current (Y/SD data/SD address/SCLK) ⁽³⁾	V _{out} = 2.4 V			−8	mA
I _{OL}	Output current (Y/SD data/SD address/SCLK)	V _{out} = 0.4 V			8	mA
I _{OH}	Output current (SDRAM_CLK)	V _{out} = 2.4 V			−8	mA
I _{OL}	Output current (SDRAM_CLK)	V _{out} = 0.4 V			8	mA
I _{OH}	Output current (C)	V _{out} = 2.4 V			−4	mA
I _{OL}	Output current (C)	V _{out} = 0.4 V			4	mA
T _A	Operating free-air temperature		0		70	°C
Analog out	Output voltage			2.0	2.4	V

(1) Exception: 0.7 AVDD18 for XIN terminal

(2) Exception: 0.3 AVDD18 for XIN terminal

(3) Currents out of a terminal are given as a negative number

6.3 Crystal Specifications

CRYSTAL SPECIFICATION	MIN	NOM	MAX	UNIT
Frequency		14.31818		MHz
Frequency tolerance ⁽¹⁾	-50		50	ppm

(1) This number is the required specification for the external crystal/oscillator and is not tested.

6.4 DC Electrical Characteristics

For minimum/maximum values: IOVDD = 3.0 V to 3.6 V, DVDD = 1.65 V to 1.95 V, AV_{DD33} = 3.0 V to 3.6 V, AV_{DD18} = 1.65 V to 1.95 V, T_A = 0°C to 70°C. For typical values: IOVDD = 3.3 V, DVDD = 1.8 V, AV_{DD33} = 3.3 V, AV_{DD18} = 1.8 V, T_A = 25°C

PARAMETER	TEST CONDITIONS	MIN	TYP	MAX	UNIT
I _{DD(IOD)} 3.3-V IO digital supply current ⁽¹⁾	CVBS, 3DYC, 3DNR		28	33	mA
	S-Video, 3DNR		23	27	
	SCART		33	39	
	480p/525p		52	63	
I _{DD(D)} 1.8-V digital supply current	CVBS		159	190	mA
	S-Video		156	187	
	SCART		172	206	
	480p/525p		205	246	
I _{DD(33A)} 3.3-V analog supply current	CVBS		18	21	mA
	S-Video		31	37	
	SCART		38	45	
	480p/525p		35	42	
I _{DD(18A)} 1.8-V analog supply current	CVBS		80	96	mA
	S-Video		136	163	
	SCART		138	165	
	480p/525p		138	165	
P _{TOT} Total power dissipation, normal operation	CVBS, 3DYC, 3DNR		582	698	mW
	S-Video, 3DNR		704	845	
	SCART		792	950	
	480p/525p		904	1085	
P _{SAVE} Total power dissipation, power save				180	mW
P _{DOWN} Total power dissipation, power down				3	mW
I _{lkg} Input leakage current ⁽¹⁾				10	μA
C _I Input capacitance	by design (not tested)			8	pF
V _{OH} Output voltage high (Y/SD data/SD address/SCLK)	I _{OH} = -8 mA	0.8 IOVDD			V
V _{OL} Output voltage low (Y/SD data/SD address/SCLK)	I _{OL} = 8 mA		0.2 IOVDD		V
V _{OH} Output voltage high (SDRAM_CLK)	I _{OH} = -8 mA	0.8 IOVDD			V
V _{OL} Output voltage LOW (SDRAM_CLK)	I _{OL} = 8 mA		0.2 IOVDD		V
V _{OH} Output voltage HIGH (C)	I _{OH} = -4 mA	0.8 IOVDD			V
V _{OL} Output voltage LOW (C)	I _{OL} = 4 mA		0.2 IOVDD		V

(1) GLCO and GPIO are bidirectional pins with an internal pulldown resistor during reset. These pins may sink up to 30 μA during reset.

6.5 Analog Processing and A/D Converters

 $F_s = 60$ MSPS for CH1, CH2

PARAMETER		TEST CONDITIONS	MIN	TYP	MAX	UNIT
Z_i	Input impedance, analog video inputs	specified by design (not tested)	200			k Ω
C_i	Input capacitance, analog video inputs	specified by design (not tested)				pF
$V_{i(PP)}$	Input voltage range	$C_{coupling} = 0.1 \mu F$	0.50	1.0		V
ΔG	Input gain control range		–6.7			dB
	Input gain ratio, $N = 0$ to 15		–7.5%	$0.5 + N/10$		
	Input offset control per step		2	4		LSB
DNL	Absolute differential nonlinearity	AFE only		0.75		LSB
INL	Absolute integral nonlinearity	AFE only		1		LSB
FR	Frequency response	Multiburst (60 IRE)		–0.9		dB
XTALK	Crosstalk	1 MHz				dB
SNR	Signal-to-noise ratio all channels	$F_{IN} = 1$ MHz, $1.0 V_{PP}$		54		dB
GM	Gain match ⁽¹⁾	Full scale, 1 MHz		1.5		%
NS	Noise spectrum	Luma ramp (100 kHz to full, tilt null)		–58		dB
DP	Differential phase	Modulated ramp		0.5		°
DG	Differential gain	Modulated ramp		± 1.5		%
	Analog output gain ratio, $N = 0$ to 15		–8%	$1.3 + 0.26xN$	8	%

(1) Component inputs only

6.6 Data Clock, Video Data, Sync Timing

PARAMETER		TEST CONDITIONS	MIN	TYP	MAX	UNIT
	Duty cycle SCLK		45	50	55	%
t_1	High time, SCLK @ 13.5 MHz	$\geq 50\%$		37		ns
t_1	High time, SCLK @ 27 MHz	$\geq 50\%$		18.5		
t_1	High time, SCLK @ 54 MHz	$\geq 50\%$		9.25		
t_2	Low time, SCLK @ 13.5 MHz	$\leq 50\%$		37		ns
t_2	Low time, SCLK @ 27 MHz	$\leq 50\%$		18.5		
t_2	Low time, SCLK @ 54 MHz	$\leq 50\%$		9.25		
t_3	Fall time, SCLK	90% to 10%			5	ns
t_4	Rise time, SCLK	10% to 90%			5	ns
t_5	Data valid time	To 90%/10%			5	ns
t_6	Data hold time	To 90%/10%	2.5			ns

6.7 I²C Host Port Timing

PARAMETER	TEST CONDITIONS	MIN	TYP	MAX	UNIT
t ₁	Bus free time between STOP and START	1.3			μs
t ₂	Data hold time	0		0.9	μs
t ₃	Data setup time	100			ns
t ₄	Setup time for a (repeated) START condition	0.6			μs
t ₅	Setup time for a STOP condition	0.6			μs
t ₆	Hold time (repeated) START condition	0.6			μs
t ₇	Rise time VC1(SDA) and VC0(SCL) signal	specified by design ⁽¹⁾		250	ns
t ₈	Fall time VC1(SDA) and VC0(SCL) signal	specified by design ⁽¹⁾		250	ns
C _b	Capacitive load for each bus line	specified by design ⁽¹⁾		400	pF
f _{12C}	I ² C clock frequency			400	kHz

(1) Assured by design. Not tested.

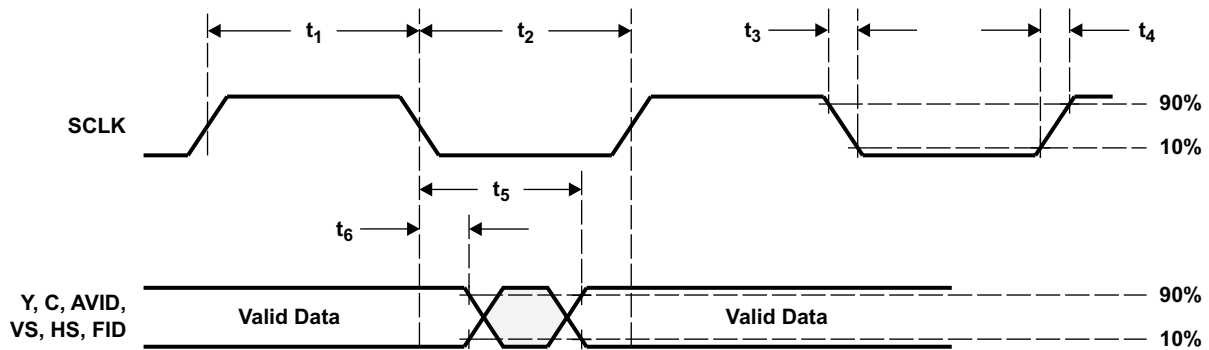

Figure 6-1. Clocks, Video Data, and Sync Timing

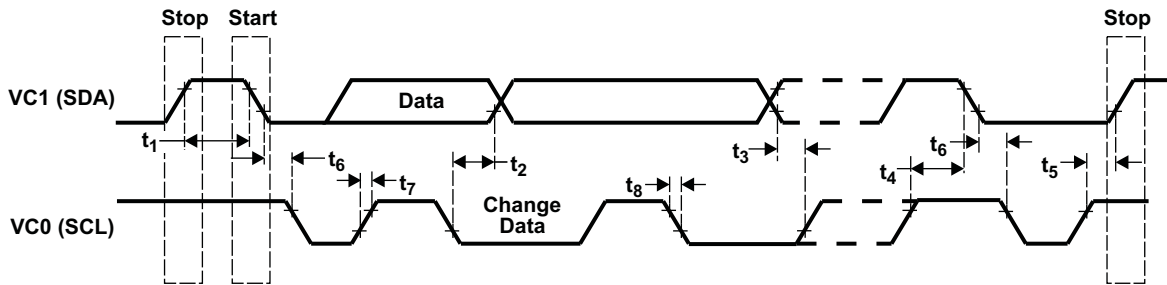

Figure 6-2. I²C Host Port Timing

6.8 SDRAM Timing⁽¹⁾

$C_L = 10$ pF, CAS latency = 3, Clock delay = 0 ns

PARAMETER	TEST CONDITIONS	MIN	TYP	MAX	UNIT
t_1	Clock period (108 MHz)		9.2		ns
t_2	Clock high period		4.6		ns
t_3	Clock low period		4.6		ns
t_4	Clock to output valid time (address/data/control)			5.3	ns
t_5	Output hold time	1.8			ns
t_6	Data in setup time	1.1			ns
t_7	Data in hold time	0.3			ns
t_8	Clock rise time, 10% to 90%			4	ns
t_g	Clock fall time, 90% to 10%			4	ns

(1) Assured by design. Not tested.

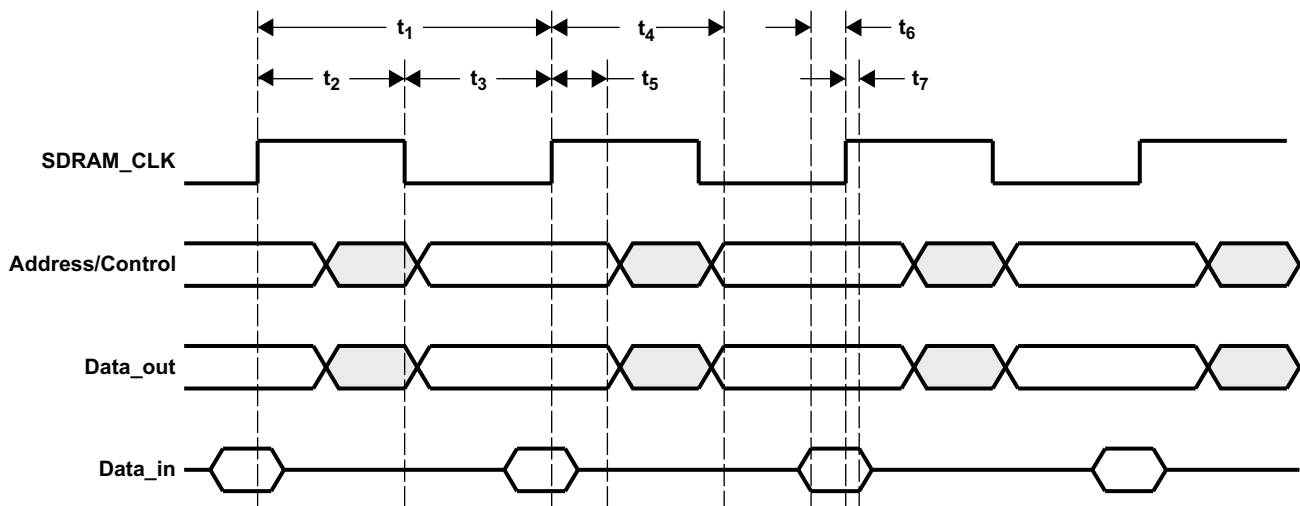

Figure 6-3. SDRAM Interface Timing

6.9 Example SDRAM Timing Alignment

Samsung K4S161622E-80, CAS latency = 3, Clock delay = 0 ns

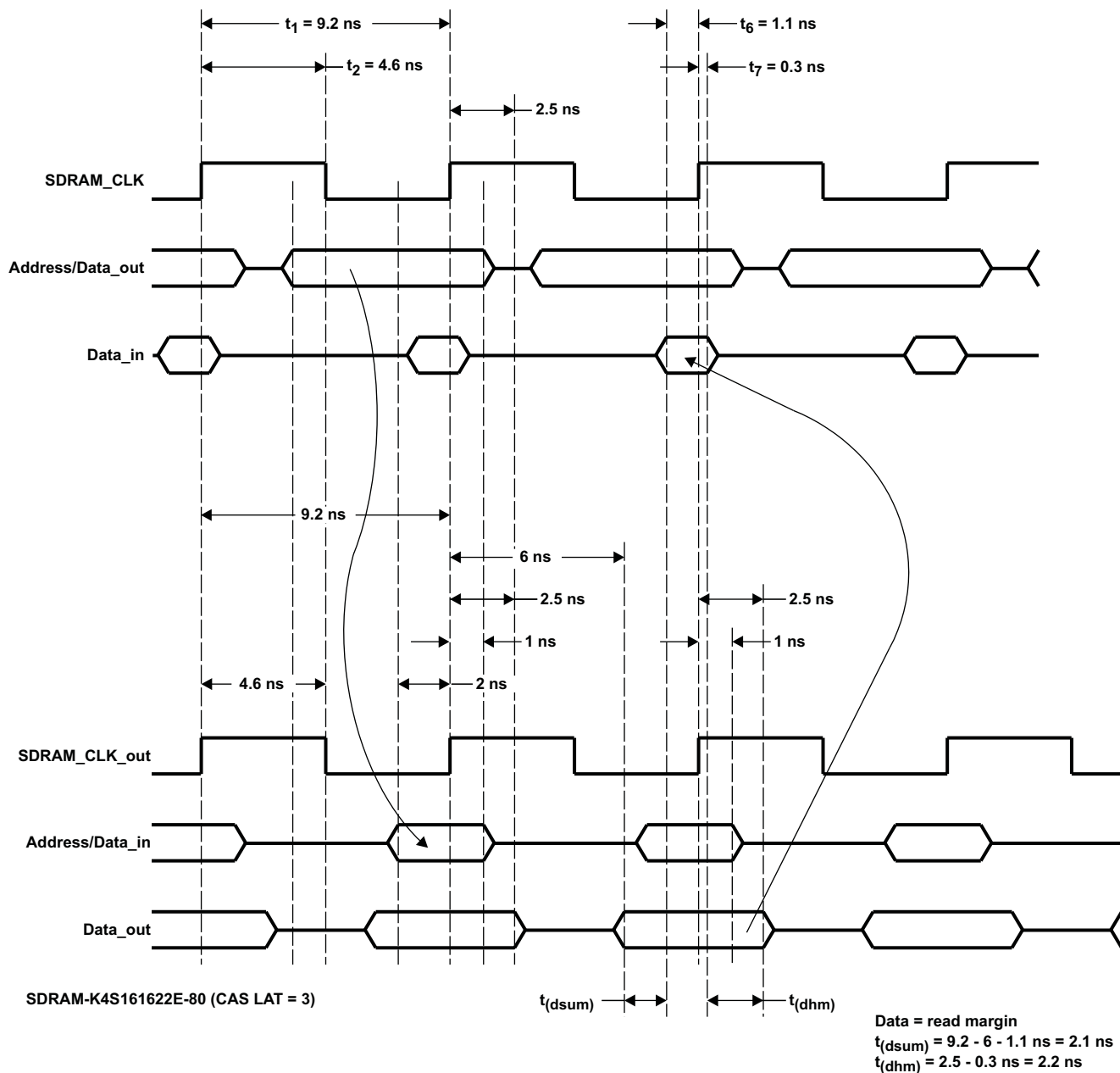

Figure 6-4. TVP5160 Timing Relationship with K4S161622E-80 SDRAM

6.10 Memories Tested

Table 6-1. Memories Tested

MANUFACTURER	PART NUMBER	SIZE	MBYTES	SPEED	PINS	3DYC	3DNR	3DYC+3DNR
Samsung	K4S641632H-TC75	4 Meg x 16	8 MB	133 MHz	54	Y	Y	Y
Samsung	K4S641632H-TC70	4 Meg x 16	8 MB	143 MHz	54	Y	Y	Y
Samsung	K4S161622E-TC60	1 Meg x 16	2 MB	166 MHz	50	Y	Y	N
Samsung	K4S161622H-TC60	1 Meg x 16	2 MB	166 MHz	54	Y	Y	N
Etron	EM638165TS-6	4 Meg x 16	8 MB	166 MHz	54	Y	Y	Y
Etron	EM638165TS-7	4 Meg x 16	8 MB	143 MHz	54	Y	Y	Y
Micron	MT48LC8M16A2TG-75	8 Meg x 16	16 MB	133 MHz	54	Y	Y	Y
Micron	MT48LC4M16A2TG-75	4 Meg x 16	8 MB	133 MHz	54	Y	Y	Y
ISSI	IS42S16100C1-7TL	1 Meg x 16	2 MB	143 MHz	50	Y	Y	N
ISSI	IS42S16400B-7TL	4 Meg x 16	8 MB	133 MHz	54	Y	Y	Y

6.11 Thermal Specification⁽¹⁾

PARAMETER		TEST CONDITIONS	MIN	TYP	MAX	UNIT
θ_{JA}	Junction-to-ambient thermal resistance, still air	Thermal pad soldered to 4-layer High-K PCB		17.17		°C/W
θ_{JC}	Junction-to-case thermal resistance, still air	Thermal pad soldered to 4-layer High-K PCB		0.12		°C/W
$T_{J(MAX)}$	Maximum junction temperature for reliable operation				105	°C

- (1) The exposed thermal pad must be soldered to a JEDEC High-K PCB with adequate ground plane. When split ground planes are used, attach the thermal pad to the digital ground plane.

7 Designing With PowerPAD™

The TVP5160 device is housed in a high-performance, thermally enhanced, 128-pin PowerPAD package (TI package designator: 128PFP). Use of the PowerPAD package does not require any special considerations except to note that the PowerPAD, which is an exposed die pad on the bottom of the device, is a metallic thermal and electrical conductor. Therefore, if not implementing the PowerPAD PCB features, the use of solder masks (or other assembly techniques) may be required to prevent any inadvertent shorting by the exposed PowerPAD of connection etches or vias under the package. The recommended option, however, is not to run any etches or signal vias under the device, but to have only a grounded thermal land as explained below. Although the actual size of the exposed die pad may vary, the minimum size required for the keep out area for the 128-terminal PFP PowerPAD package is 8.8 mm × 8.8 mm and is centered on the device package.

It is recommended that there be a thermal land, which is an area of solder-tinned-copper, underneath the PowerPAD package. The thermal land will vary in size, depending on the PowerPAD package being used, the PCB construction, and the amount of heat that needs to be removed. In addition, the thermal land may or may not contain numerous thermal vias depending on PCB construction.

Other requirements for thermal lands and thermal vias are detailed in the TI application note PowerPAD *Thermally Enhanced Package Application Report*, TI literature number [SLMA002](#), available via the TI web site at [www.ti.com](#).

For the TVP5160 device, this thermal land must be grounded to the low impedance ground plane of the device. This improves not only thermal performance but also the electrical grounding of the device. It is also recommended that the device ground terminal landing pads be connected directly to the grounded thermal land. The land size must be as large as possible without shorting device signal terminals. The thermal land may be soldered to the exposed PowerPAD using standard reflow soldering techniques.

While the thermal land may be electrically floated and configured to remove heat to an external heat sink, it is recommended that the thermal land be connected to the low impedance ground plane for the device. More information may be obtained from the TI application note *PHY Layout*, TI literature number [SLLA020](#).

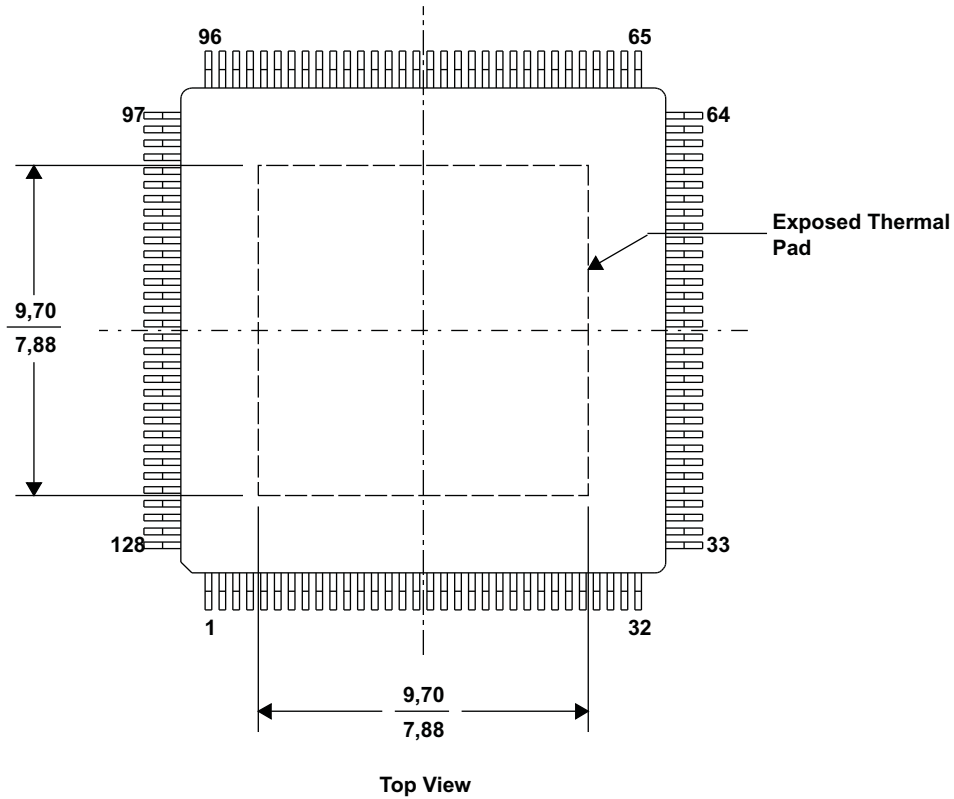

NOTE: All linear dimensions are in millimeters

Figure 7-1. 128-Pin PowerPAD Package

8 Revision History

Table 8-1. Revision History

REVISION	COMMENTS
SLES135	Initial release
SLES135A	Unknown
SLES135B	<p>Section 1.4, Related Products section added.</p> <p>Section 1.5, Trademarks modified.</p> <p>Table 1-1, I/O type modified for SCL pin.</p> <p>Table 2-1, Specified Y/C separation support by video standard.</p> <p>Figure 2-4, Crystal parallel resistor recommendation added.</p> <p>Table 2-9, CGMS support added for PAL.</p> <p>Table 2-11, Signal names modified.</p> <p>Table 3-1, Brightness & Contrast Range Extender register added.</p> <p>Table 3-13, Brightness control register description modified.</p> <p>Table 3-14, Color saturation control register description modified.</p> <p>Table 3-15, Contrast control register description modified.</p> <p>Table 3-19, R/Pr saturation control register description modified.</p> <p>Table 3-20, G/Y contrast control register description modified.</p> <p>Table 3-21, B/Pb saturation control register description modified.</p> <p>Table 3-22, G/Y brightness control register description modified.</p> <p>Table 3-39, Brightness & Contrast Range Extender register added.</p> <p>Table 3-128, CGMS support added.</p> <p>Table 3-130, CGMS support added.</p> <p>Table 3-132, CGMS support added.</p> <p>Table 3-134, CGMS support added.</p> <p>Table 3-137, CGMS support added.</p> <p>Section 6.11, Thermal specification added.</p> <p>Made minor editorial changes throughout.</p>
SLES135C	Made minor editorial changes throughout.
SLES135D	<p>Section 2.9.1, Removed statement about internal pulldown on I2CAx terminals.</p> <p>Section 6.11, Updated table</p>
SLES135E	<p>Table 3-1, Added RAM version MSB and LSB registers (subaddresses: 71h, 82h)</p> <p>Table 3-82, Added RAM version MSB register (subaddress: 71h)</p> <p>Table 3-90, Added RAM version LSB register (subaddress: 82h)</p>

PACKAGING INFORMATION

Orderable Device	Status (1)	Package Type	Package Drawing	Pins	Package Qty	Eco Plan (2)	Lead finish/ Ball material (6)	MSL Peak Temp (3)	Op Temp (°C)	Device Marking (4/5)	Samples
TVP5160PNP	ACTIVE	HTQFP	PNP	128	90	RoHS & Green	NIPDAU	Level-3-260C-168 HR	0 to 70	TVP5160	Samples

(1) The marketing status values are defined as follows:

ACTIVE: Product device recommended for new designs.

LIFEBUY: TI has announced that the device will be discontinued, and a lifetime-buy period is in effect.

NRND: Not recommended for new designs. Device is in production to support existing customers, but TI does not recommend using this part in a new design.

PREVIEW: Device has been announced but is not in production. Samples may or may not be available.

OBSELETE: TI has discontinued the production of the device.

(2) **RoHS:** TI defines "RoHS" to mean semiconductor products that are compliant with the current EU RoHS requirements for all 10 RoHS substances, including the requirement that RoHS substance do not exceed 0.1% by weight in homogeneous materials. Where designed to be soldered at high temperatures, "RoHS" products are suitable for use in specified lead-free processes. TI may reference these types of products as "Pb-Free".

RoHS Exempt: TI defines "RoHS Exempt" to mean products that contain lead but are compliant with EU RoHS pursuant to a specific EU RoHS exemption.

Green: TI defines "Green" to mean the content of Chlorine (Cl) and Bromine (Br) based flame retardants meet JS709B low halogen requirements of <=1000ppm threshold. Antimony trioxide based flame retardants must also meet the <=1000ppm threshold requirement.

(3) MSL, Peak Temp. - The Moisture Sensitivity Level rating according to the JEDEC industry standard classifications, and peak solder temperature.

(4) There may be additional marking, which relates to the logo, the lot trace code information, or the environmental category on the device.

(5) Multiple Device Markings will be inside parentheses. Only one Device Marking contained in parentheses and separated by a "-" will appear on a device. If a line is indented then it is a continuation of the previous line and the two combined represent the entire Device Marking for that device.

(6) Lead finish/Ball material - Orderable Devices may have multiple material finish options. Finish options are separated by a vertical ruled line. Lead finish/Ball material values may wrap to two lines if the finish value exceeds the maximum column width.

Important Information and Disclaimer:The information provided on this page represents TI's knowledge and belief as of the date that it is provided. TI bases its knowledge and belief on information provided by third parties, and makes no representation or warranty as to the accuracy of such information. Efforts are underway to better integrate information from third parties. TI has taken and continues to take reasonable steps to provide representative and accurate information but may not have conducted destructive testing or chemical analysis on incoming materials and chemicals. TI and TI suppliers consider certain information to be proprietary, and thus CAS numbers and other limited information may not be available for release.

In no event shall TI's liability arising out of such information exceed the total purchase price of the TI part(s) at issue in this document sold by TI to Customer on an annual basis.

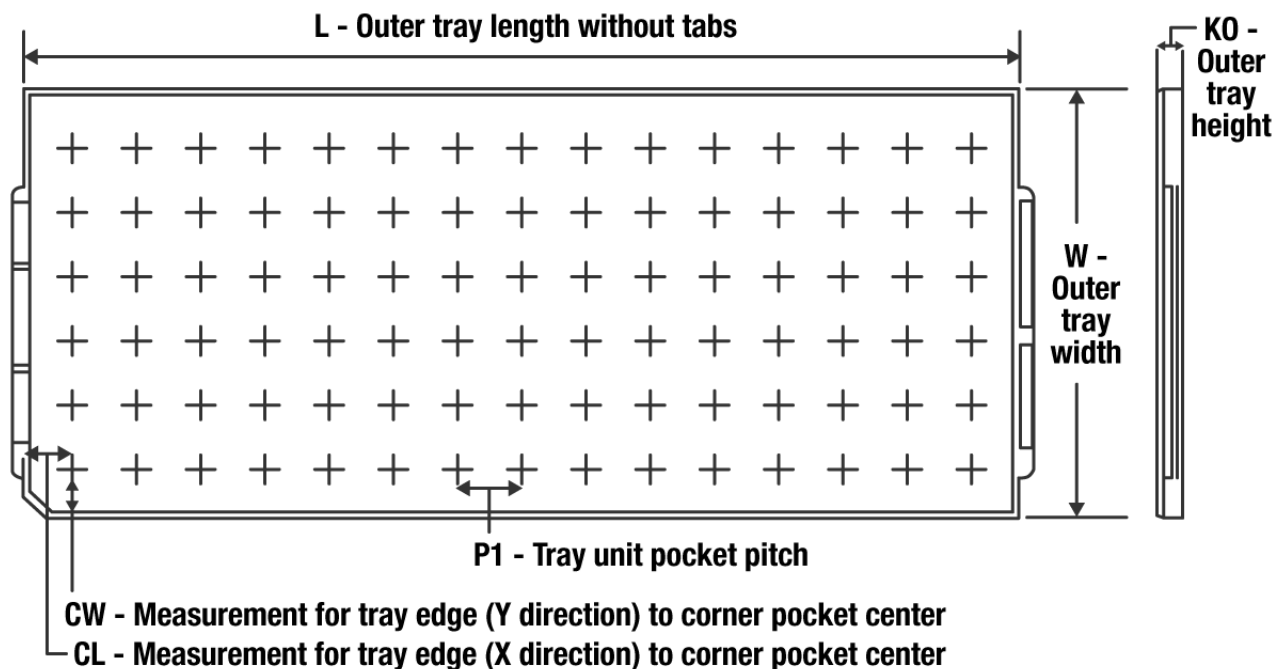
TRAY

Chamfer on Tray corner indicates Pin 1 orientation of packed units.

*All dimensions are nominal

Device	Package Name	Package Type	Pins	SPQ	Unit array matrix	Max temperature (°C)	L (mm)	W (mm)	K0 (µm)	P1 (mm)	CL (mm)	CW (mm)
TVP5160PNP	PNP	HTQFP	128	90	6 X 15	150	315	135.9	7620	20.3	15.4	15.45

MECHANICAL DATA

PNP (S-PQFP-G128)

PowerPAD™ PLASTIC QUAD FLATPACK

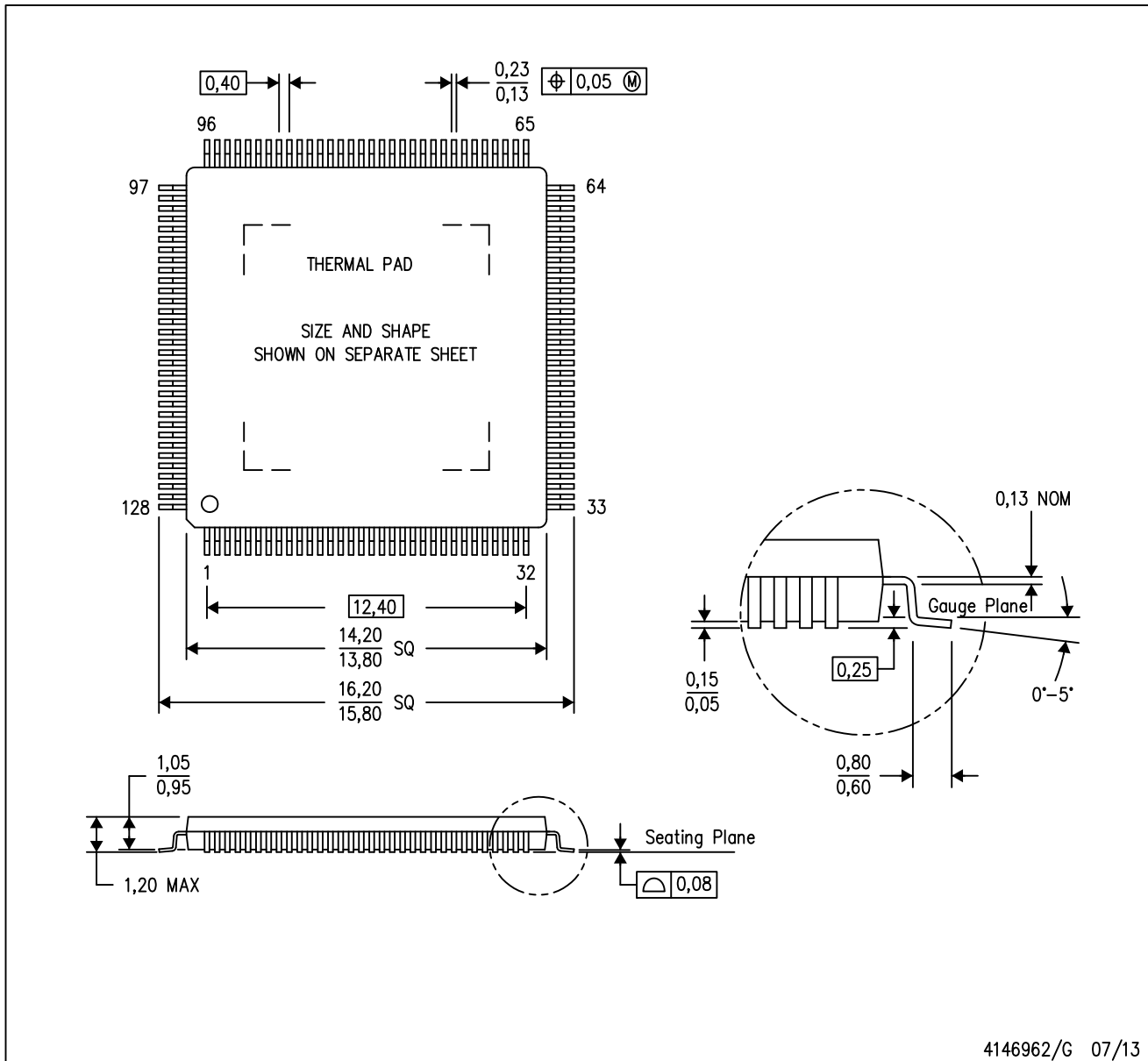

- NOTES:
- All linear dimensions are in millimeters.
 - This drawing is subject to change without notice.
 - Body dimensions do not include mold flash or protrusion
 - This package is designed to be soldered to a thermal pad on the board. Refer to Technical Brief, PowerPad Thermally Enhanced Package, Texas Instruments Literature No. SLMA002 for information regarding recommended board layout. This document is available at www.ti.com <<http://www.ti.com>>.
 - See the additional figure in the Product Data Sheet for details regarding the exposed thermal pad features and dimensions.

PowerPAD is a trademark of Texas Instruments.

THERMAL PAD MECHANICAL DATA

PNP (S-PQFP-G128)

PowerPAD™ PLASTIC QUAD FLATPACK

THERMAL INFORMATION

This PowerPAD™ package incorporates an exposed thermal pad that is designed to be attached to a printed circuit board (PCB). The thermal pad must be soldered directly to the PCB. After soldering, the PCB can be used as a heatsink. In addition, through the use of thermal vias, the thermal pad can be attached directly to the appropriate copper plane shown in the electrical schematic for the device, or alternatively, can be attached to a special heatsink structure designed into the PCB. This design optimizes the heat transfer from the integrated circuit (IC).

For additional information on the PowerPAD package and how to take advantage of its heat dissipating abilities, refer to Technical Brief, PowerPAD Thermally Enhanced Package, Texas Instruments Literature No. SLMA002 and Application Brief, PowerPAD Made Easy, Texas Instruments Literature No. SLMA004. Both documents are available at www.ti.com.

The exposed thermal pad dimensions for this package are shown in the following illustration.

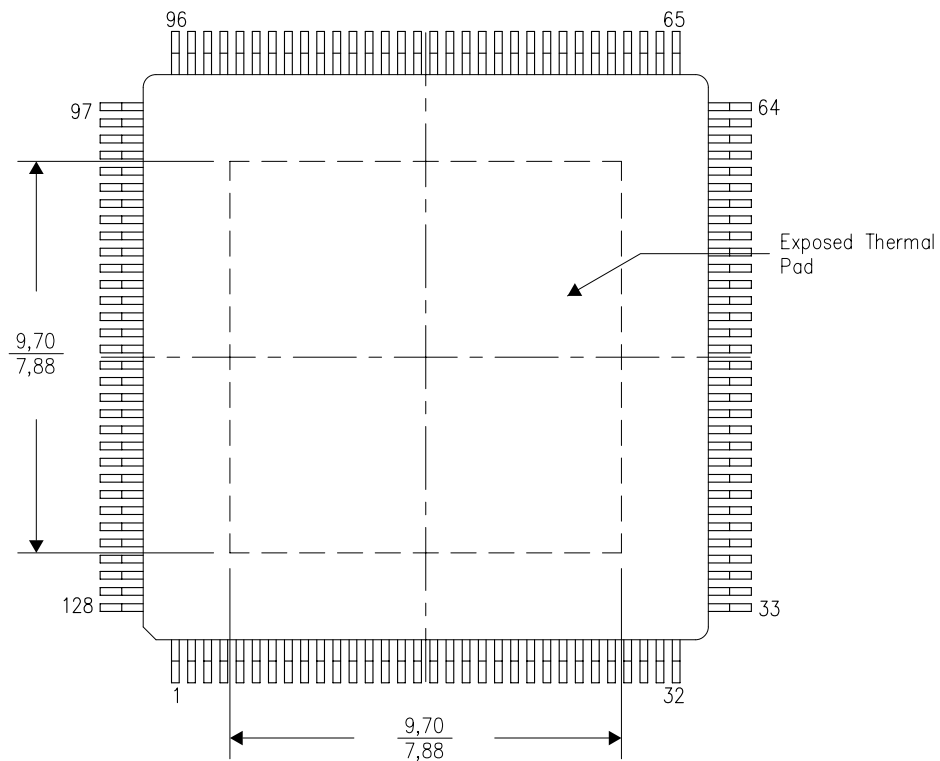

4206232-3/L 10/11

NOTE: All linear dimensions are in millimeters

PowerPAD is a trademark of Texas Instruments

PNP (S-PQFP-G128)

PowerPAD™ PLASTIC QUAD FLAT PACK

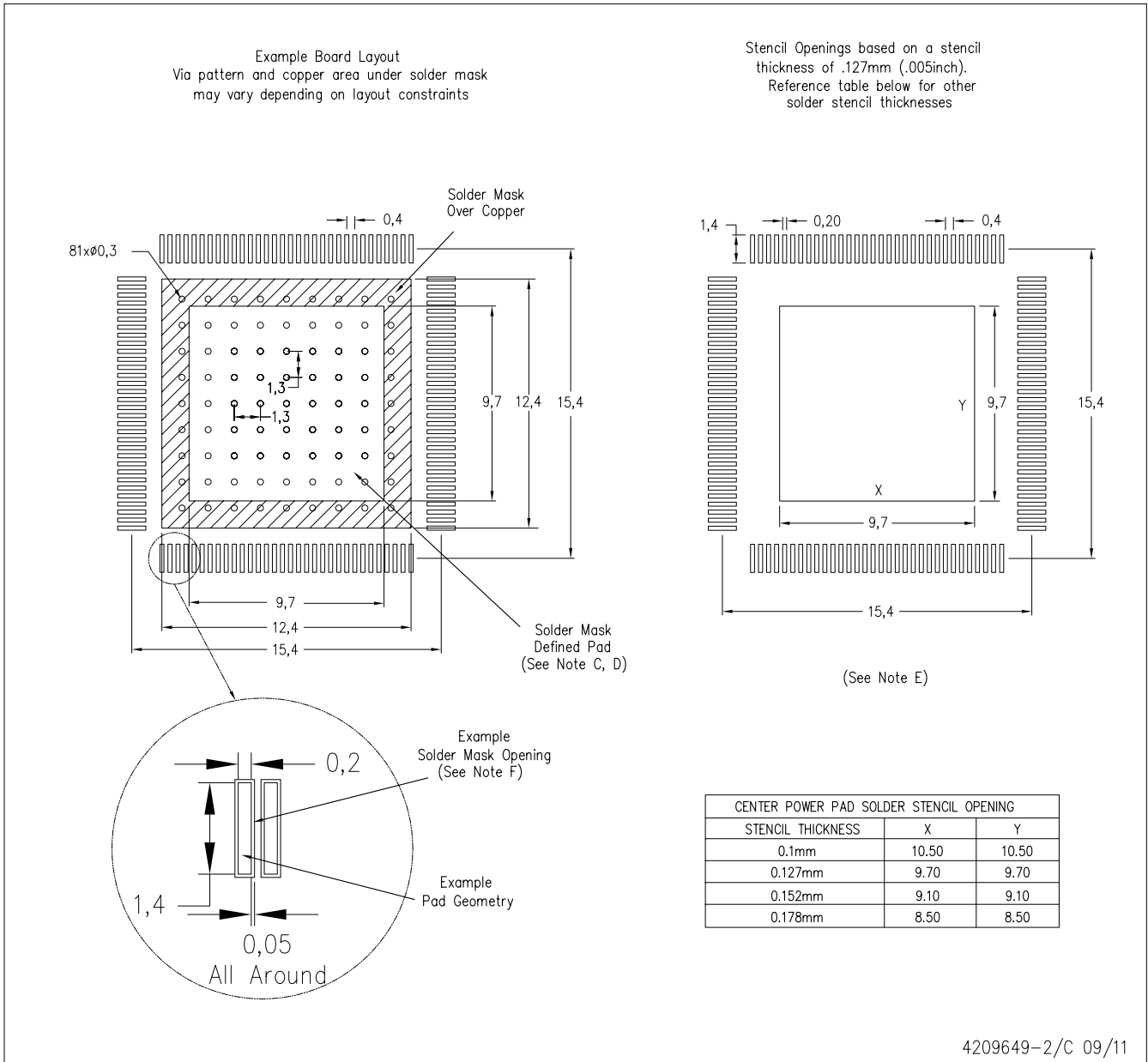

- NOTES:
- All linear dimensions are in millimeters.
 - This drawing is subject to change without notice.
 - Customers should place a note on the circuit board fabrication drawing not to alter the center solder mask defined pad.
 - This package is designed to be soldered to a thermal pad on the board. Refer to Technical Brief, PowerPad Thermally Enhanced Package, Texas Instruments Literature No. SLMA002, SLMA004, and also the Product Data Sheets for specific thermal information, via requirements, and recommended board layout. These documents are available at www.ti.com <<http://www.ti.com>>. Publication IPC-7351 is recommended for alternate designs.
 - Laser cutting apertures with trapezoidal walls and also rounding corners will offer better paste release. Customers should contact their board assembly site for stencil design recommendations. Example stencil design based on a 50% volumetric metal load solder paste. Refer to IPC-7525 for other stencil recommendations.
 - Customers should contact their board fabrication site for solder mask tolerances between and around signal pads.

PowerPAD is a trademark of Texas Instruments.

IMPORTANT NOTICE AND DISCLAIMER

TI PROVIDES TECHNICAL AND RELIABILITY DATA (INCLUDING DATA SHEETS), DESIGN RESOURCES (INCLUDING REFERENCE DESIGNS), APPLICATION OR OTHER DESIGN ADVICE, WEB TOOLS, SAFETY INFORMATION, AND OTHER RESOURCES "AS IS" AND WITH ALL FAULTS, AND DISCLAIMS ALL WARRANTIES, EXPRESS AND IMPLIED, INCLUDING WITHOUT LIMITATION ANY IMPLIED WARRANTIES OF MERCHANTABILITY, FITNESS FOR A PARTICULAR PURPOSE OR NON-INFRINGEMENT OF THIRD PARTY INTELLECTUAL PROPERTY RIGHTS.

These resources are intended for skilled developers designing with TI products. You are solely responsible for (1) selecting the appropriate TI products for your application, (2) designing, validating and testing your application, and (3) ensuring your application meets applicable standards, and any other safety, security, regulatory or other requirements.

These resources are subject to change without notice. TI grants you permission to use these resources only for development of an application that uses the TI products described in the resource. Other reproduction and display of these resources is prohibited. No license is granted to any other TI intellectual property right or to any third party intellectual property right. TI disclaims responsibility for, and you will fully indemnify TI and its representatives against, any claims, damages, costs, losses, and liabilities arising out of your use of these resources.

TI's products are provided subject to [TI's Terms of Sale](#) or other applicable terms available either on ti.com or provided in conjunction with such TI products. TI's provision of these resources does not expand or otherwise alter TI's applicable warranties or warranty disclaimers for TI products.

TI objects to and rejects any additional or different terms you may have proposed.

Mailing Address: Texas Instruments, Post Office Box 655303, Dallas, Texas 75265
Copyright © 2022, Texas Instruments Incorporated

Looking for pricing, stock, or lifecycle information?

Click below to explore more details on WIN SOURCE:

 [View TVP5160EVM](#) on WIN SOURCE

 [Texas Instruments](#) Information

Optimize Your Supply Chain with WIN SOURCE Solutions

-  Global Sourcing Solution
-  Obsolete Management
-  Cost Control Management
-  Shortage Management
-  Alternative Solution
-  Excess Inventory Management