



**THE DATASHEET OF
TSS-113-01-L-D**



DO NOT SCALE FROM THIS PRINT

TSS-1XX-XX-XXX-X-XX-XX

NO OF POSITIONS
-02 THRU -18 & 20, 21, 24, 25, 28, 30, 32, 36 (PER ROW)

LEAD STYLE
SEE TABLE 1

PLATING SPECIFICATION
-G: GOLD, 10µ" Au / 50µ" Ni NICKEL MIN ON CONTACT, 3µ" AU / 50µ" NI MIN ON TAIL
-T: MATTE TIN CONTACT AND TAIL
-S: SELECTIVE, 30µ" Au / 50µ" Ni MIN ON CONTACT, MATTE TIN TAIL
-L: LIGHT SELECTIVE, 10µ" Au / 50µ" Ni MIN ON CONTACT, MATTE TIN TAIL
-H: HEAVY GOLD, 30µ" Au / 50µ" Ni MIN ON CONTACT, 3µ" Au / 50µ" Ni MIN ON TAIL
-F: FLASH SELECTIVE, 3µ" Au / 50µ" Ni MIN ON CONTACT, MATTE TIN TAIL
-STL: SELECTIVE, 30µ" Au / 50µ" Ni MIN ON CONTACT, TIN/LEAD (90/10+/-5%) TAIL (AVAILABLE IN -01 STYLE ONLY)
-SS: STRIPE SELECTIVE, 30µ" Au / 50µ" Ni MIN ON CONTACT, MATTE TIN TAIL (SEE NOTE 7)

POLARIZE OPTION
XX INDICATES POSITION OMITTED

OPTION
BLANK: STRAIGHT (STYLE 04 & 05 N/A)
-RA: RIGHT ANGLE (STYLE -01, -02 & -03 N/A)
-LL: LOCKING LEAD
-LA: -RA OPTION WITH -LL OPTION

ROW SPECIFICATION
-D: DOUBLE
-S: SINGLE

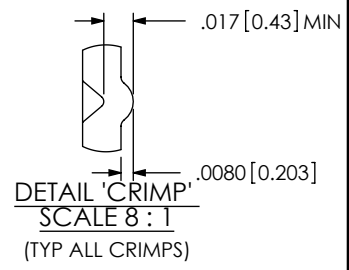
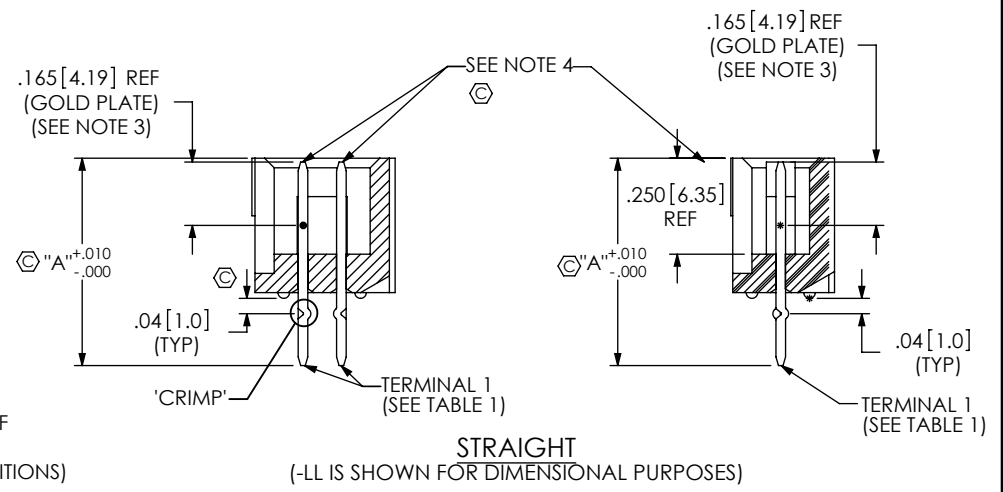
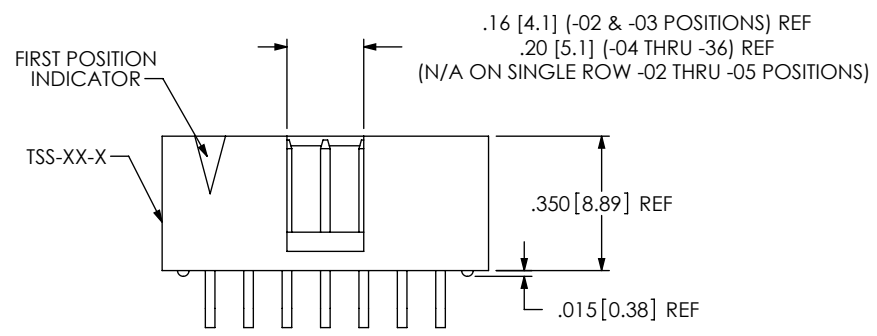
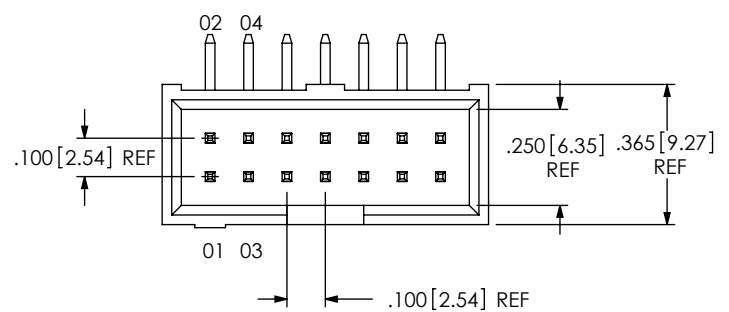
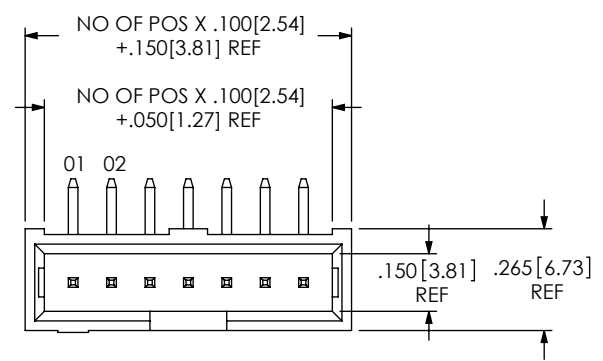

NOTES:

- ⊗ REPRESENTS A CRITICAL DIMENSION.
- MINIMUM PUSHOUT FORCE: 3 LB.
- ASSEMBLE GOLD PLATED END AS SHOWN.
- TERMINALS TO BE FLUSH TO .010 [.25] BELOW TOP OF SHROUD.
- TSS-1XX-04-X-D-RA-XX ASSEMBLIES ARE TO BE PACKAGED IN A PT-1-24-01-40 TUBE WITH TWO TP-13 PLUGS PER TUBE (ALL POSITIONS).
- ORIENTATE PINS TO REDUCE THE NUMBER OF BANDOLIERS MARKS IN THE POST AREA (SEE TABLE 2).
- AVAILABLE ON STRAIGHT LEAD STYLES -01, -02, -03 AND ON -RA LEAD STYLE -04. MATES WITH SSW, SSQ, SSM, BCS, ESW & ESQ ONLY.

<p>UNLESS OTHERWISE SPECIFIED, DIMENSIONS ARE IN INCHES. TOLERANCES ARE:</p> <p>DECIMALS ANGLES</p> <p>.XX: ±.01 [.3] 2°</p> <p>.XXX: ±.005 [.13]</p> <p>.XXXX: ±.0020 [.051]</p>	<p>PROPRIETARY NOTE</p> <p>THIS DOCUMENT CONTAINS INFORMATION CONFIDENTIAL AND PROPRIETARY TO SAMTEC, INC. AND SHALL NOT BE REPRODUCED OR TRANSFERRED TO OTHER DOCUMENTS OR DISCLOSED TO OTHERS OR USED FOR ANY PURPOSE OTHER THAN THAT WHICH IT WAS OBTAINED WITHOUT THE EXPRESSED WRITTEN CONSENT OF SAMTEC, INC.</p>	<p>DESCRIPTION:</p> <p>SLIM TOP SHROUD TERMINAL STRIP</p>	
		<p>DWG. NO.:</p> <p>TSS-1XX-XX-XXX-X-XX-XX</p>	
<p>MATERIAL: DO NOT SCALE DRAWING SHEET SCALE: 2:1</p> <p>INSULATOR: PBT, UL 94 VO, COLOR: BLACK</p> <p>TERMINAL: PHOSPHOR BRONZE</p>		<p>BY: JORDAN 01/23/1990 SHEET 1 OF 2</p>	



520 PARK EAST BLVD, NEW ALBANY, IN 47150
PHONE: 812-944-6733 FAX: 812-948-5047
e-Mail: info@SAMTEC.com code: 55322

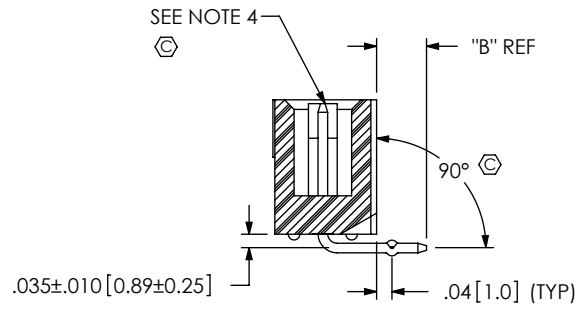
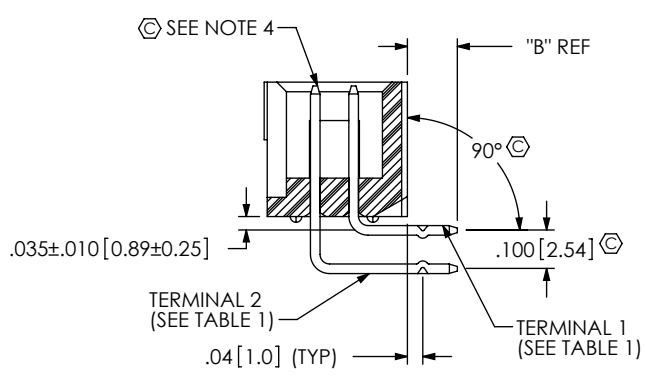

RIGHT ANGLE
(-LA IS SHOWN FOR DIMENSIONAL PURPOSES)

TABLE 2 (-T PLATING ONLY)

LEAD STYLE	NUMBER OF BAND MARKS ALLOWED IN THE POST AREA	
	PIN A	PIN B
-01	1	1
-02	1	1
-03	*0	*0
-04-RA	1	*0
-05-RA	*0	*0

* PINS TO BE FLIPPED OPPOSITE OF SELECTIVE PLATING BEFORE BEING INSERTED

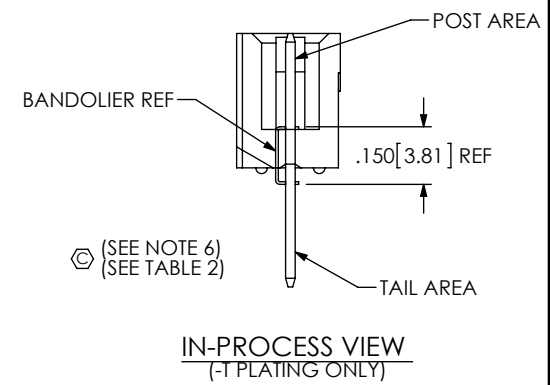
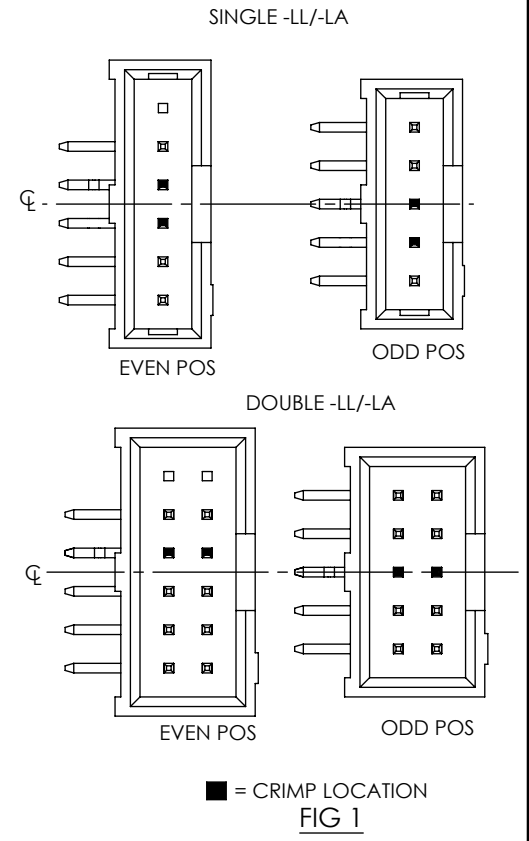
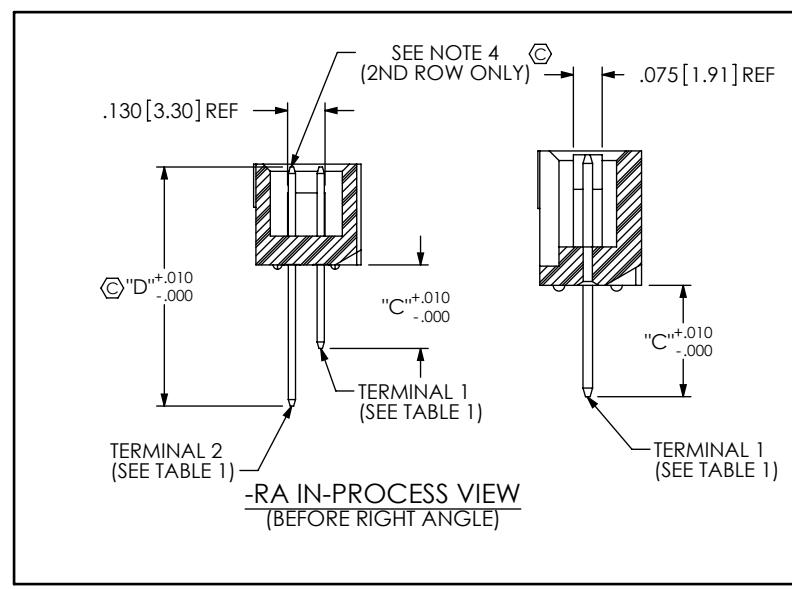

TABLE 1

LEAD STYLE	"A"	"B"	"C"	"D"	TERMINAL 1	TERMINAL 2
-01	.480 [12.19]	N/A	N/A	N/A	T-1S6-17-X-2	N/A
-02	.530 [13.46]	N/A	N/A	N/A	T-1S6-08-X-2	N/A
-03	.930 [23.62]	N/A	N/A	N/A	T-1S6-11-X-2	N/A
-04	N/A	.130 [3.30]	.280 [7.11]	.830 [21.08]	T-1S6-15-X-2	T-1S6-10-X-2
-05	N/A	.230 [5.84]	.380 [9.65]	.930 [23.62]	T-1S6-09-X-2	T-1S6-11-X-2

PROPRIETARY NOTE
THIS DOCUMENT CONTAINS INFORMATION CONFIDENTIAL AND PROPRIETARY TO SAMTEC, INC. AND SHALL NOT BE REPRODUCED OR TRANSFERRED TO OTHER DOCUMENTS OR DISCLOSED TO OTHERS OR USED FOR ANY PURPOSE OTHER THAN THAT WHICH IT WAS OBTAINED WITHOUT THE EXPRESSED WRITTEN CONSENT OF SAMTEC, INC.

DO NOT SCALE DRAWING
SHEET SCALE: 2:1

samtec
520 PARK EAST BLVD, NEW ALBANY, IN 47150
PHONE: 812-944-6733 FAX: 812-948-5047
e-Mail: info@SAMTEC.com code: 55322

DESCRIPTION: **SLIM TOP SHROUD TERMINAL STRIP**
DWG. NO. **TSS-1XX-XX-XXX-X-XX-XX**
BY: JORDAN 01/23/1990 SHEET 2 OF 2

Looking for pricing, stock, or lifecycle information?

Click below to explore more details on WIN SOURCE:

 [View TSS-113-01-L-D on WIN SOURCE](#)

 [Samtec Inc. Information](#)

Optimize Your Supply Chain with WIN SOURCE Solutions

-  Global Sourcing Solution
-  Obsolete Management
-  Cost Control Management
-  Shortage Management
-  Alternative Solution
-  Excess Inventory Management