



**THE DATASHEET OF
TSM-103-01-L-SV-P-TR**



TABLE 1						
STYLE	"B"	"C"	"D" MAX	"E"	"F"	TERMINAL
-01	.230[5.84]	.280[7.11]	.208[5.28]	.445[11.30]	.165 [4.19]	T-1S6-16-X-2
-02	.320[8.13]	.370[9.40]	.205[5.20]	.530[13.46]	.165 [4.19]	T-1S6-08-X-2
-03	.420[10.67]	.470[11.94]	.205[5.20]	.630[16.00]	.165 [4.19]	T-1S6-15-X-2
-04	.120[3.05]	.270[6.86]	.208[5.28]	.335[8.51]	.050 [1.27]	T-1S6-21-X-2
-05	.075[1.91]	.270[6.86]	.223[5.66]	.300[7.62]	.050 [1.27]	T-1S6-18-X-2

DO NOT SCALE FROM THIS PRINT

TSM-1XX-XX-XXX-SV-XX-XXX-XX

No OF POSITIONS
-02 THRU -50

LEAD STYLE
SEE TABLE 1

PLATING SPECIFICATION

- T: MATT TIN CONTACT AND TAIL
- S: SELECTIVE, 30 Au / 50 Ni MIN ON CONTACT, MATTE TIN TAIL
- G: GOLD, 10 Au / 50 Ni MIN ON CONTACT, 3 Au / 50 Ni MIN ON TAIL
- L: LIGHT SELECTIVE, 10 Au / 50 Ni MIN ON CONTACT, MATTE TIN ON TAIL
- F: FLASH SELECTIVE, 3 Au / 50 Ni MIN ON CONTACT, MATTE TIN TAIL
- H: HEAVY GOLD, 30 Au / 50 Ni MIN ON CONTACT, 3 Au / 50 Ni MIN ON TAIL
- TL: TIN / LEAD (90/10+/-5%) CONTACT AND TAIL [LEAD STYLE -01 & -02 ONLY]
- STL: SELECTIVE, 30 Au / 50 Ni MIN ON CONTACT, TIN/LEAD (90/10+/-5%) TAIL [LEAD STYLE -01 & -02 ONLY]
- TM: MATTE TIN CONTACT AND TAIL
- SM: SELECTIVE, 30 Au / 50 Ni MIN ON CONTACT, MATTE TIN TAIL
- LM: LIGHT SELECTIVE, 10 Au / 50 Ni MIN ON CONTACT, MATTE TIN TAIL
- FM: FLASH SELECTIVE, 3 Au / 50 Ni MIN ON CONTACT, MATTE TIN TAIL
- SS: STRIPE SELECTIVE, 30 Au / 50 Ni MIN ON CONTACT, MATTE TIN TAIL (SEE NOTE 9)

OPTION #3

- P: PICK & PLACE PAD (SEE FIG. 3)
[USE PPP-07] [4 POS MINIMUM OR -02 & -03 POS WITH -TR & -FR] (SEE NOTE 7)
- TR: TAPE & REEL (SEE NOTE 7 & 12) (-02 THRU -22 POS)
- FR: FULL REEL QTY. TAPE & REEL (-02 THRU -22 POS) (SEE NOTE 7 & 11)

OPTION #2

POLARIZED POSITION: SPECIFY PIN OMITTED

OPTION #1

- LC: LOCKING CLIP (SEE FIG. 1) (SEE NOTE 8)
[USE LC-08-TM-02] [-03 THRU -36 POS: 2 PER STRIP, -02 POS: 1 PER STRIP]
- A: ALIGNMENT PIN (SEE FIG. 2)

ROW SPECIFICATION

-SV: SINGLE VERTICAL (USE TSM-XX-SV-XX)

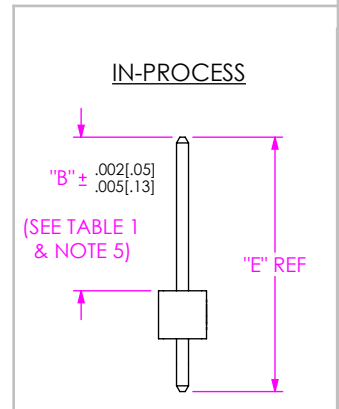
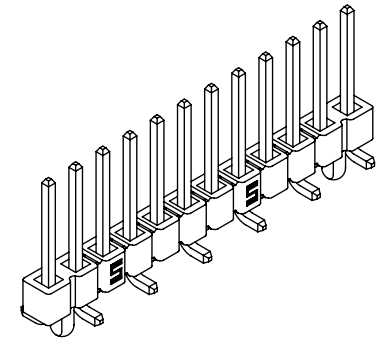
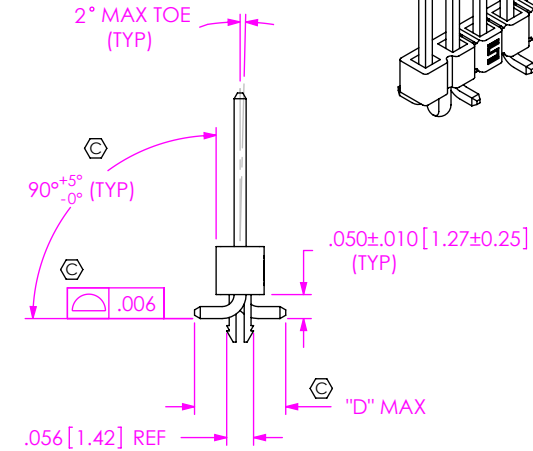
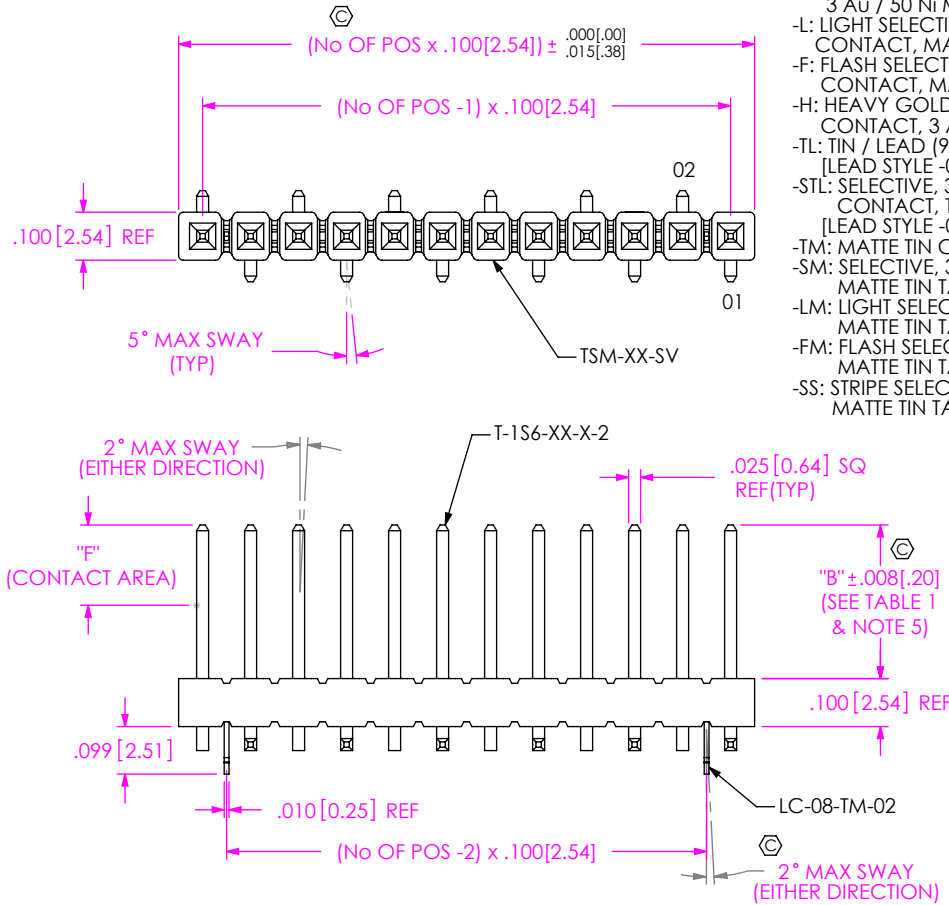

NOTES:

1. Ⓢ REPRESENTS A CRITICAL DIMENSION.
2. COPLANARITY TO BE WITHIN .006[.15].
3. BURR ALLOWANCE: .0015[.038] MAX.
4. MAXIMUM CUT FLASH: .015[.38] MAXIMUM ON TOP & SIDES OF BODY AND .030[.76] MAXIMUM ON SURFACE MOUNT SIDE OF BODY.
5. POST HEIGHT VARIATION BETWEEN ANY TWO PINS: .005[.13] MAXIMUM.
6. MAXIMUM ALLOWABLE BOW: .002[.05] INCH/INCH AFTER ASSEMBLY.
7. LEADS MAY NOT BE VISIBLE FOR CUSTOMER VISUAL INSPECTION WITH -P OPTION ON SMALLER POSITIONS PARTS.
8. DUE TO THE HIGH AMOUNT OF INSERTION FORCE NEEDED, THE -LC OPTION IS NOT COMPATIBLE WITH AUTO PLACEMENT. SAMTEC RECOMMENDS MANUAL PLACEMENT FOR ALL ASSEMBLIES WITH THE -LC OPTION.
9. -01 LEAD STYLE ONLY, MATES WITH SSW, SSQ, BCS, SSM, ESW, ESQ.
10. MINIMUM PUSHOUT FORCE: 2LB. [8.90 N].
11. -FR OPTIONS WILL BE SHIPPED AT THE MAX QUANTITY PER REEL, BASED ON OPTIONS SELECTED.
12. -TR OPTION ORDERS INVOLVING PARTIAL REEL QUANTITIES MAY BE PACKAGED ACCORDING TO THE SAMTEC PACKAGING EFFICIENCY STANDARDS (SPES) FOUND ON WWW.SAMTEC.COM.

FIG 1
TSM-112-02-XXX-SV-LC SHOWN

UNLESS OTHERWISE SPECIFIED, DIMENSIONS ARE IN INCHES.
TOLERANCES ARE:
DECIMALS ANGLES
.XX: ±.01 [.3] 2°
.XXX: ±.005 [.13]
.XXXX: ±.0020 [.051]

PROPRIETARY NOTE
THIS DOCUMENT CONTAINS CONFIDENTIAL AND PROPRIETARY INFORMATION AND ALL DESIGN, MANUFACTURING, REPRODUCTION, USE, PATENT RIGHTS AND SALES RIGHTS ARE EXPRESSLY RESERVED BY SAMTEC, INC. THIS DOCUMENT SHALL NOT BE DISCLOSED, IN WHOLE OR PART, TO ANY UNAUTHORIZED PERSON OR ENTITY NOR REPRODUCED, TRANSFERRED OR INCORPORATED IN ANY OTHER PROJECT IN ANY MANNER WITHOUT THE EXPRESS WRITTEN CONSENT OF SAMTEC, INC.

MATERIAL: DO NOT SCALE DRAWING

INSULATOR:
LCP, UL 94 VO
COLOR: BLACK

TERMINAL: PHOS BRONZE

F:\DWG\MISC\MKTG\TSM-1XX-XX-XXX-SV-XX-XXX-XX-MKT.SLDDRW

SHEET SCALE: 2.5:1



520 PARK EAST BLVD, NEW ALBANY, IN 47150
PHONE: 812-944-6733 FAX: 812-948-5047
e-Mail info@SAMTEC.com code 55322

DESCRIPTION: SINGLE ROW .100 SMT ASSEMBLY

DWG. NO. TSM-1XX-XX-XXX-SV-XX-XXX-XX

BY: DEAN P 8/21/2002 SHEET 1 OF 2

FIG 3
 -P: PICK & PLACE PAD OPTION
 4 POSITION MINIMUM
 [PLACE PAD ON CENTERLINE AS SHOWN]

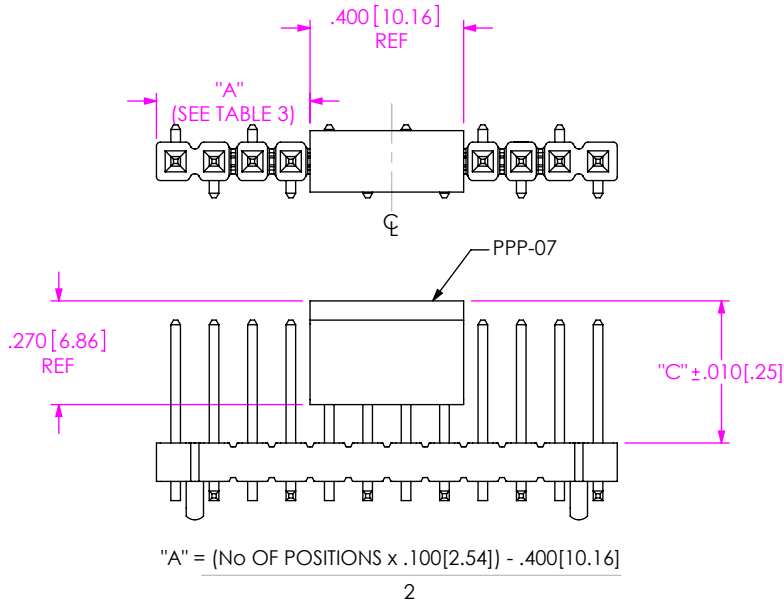

POSITION	TOLERANCE
-02 THRU -04	"A" ± .010
-05 THRU -50	"A" ± .020

FIG 2
 -A: ALIGNMENT PIN OPTION
 TSM-112-02-X-SV-A SHOWN
 [DIFFERENT AS SHOWN, OTHERWISE SAME AS FIG 1]

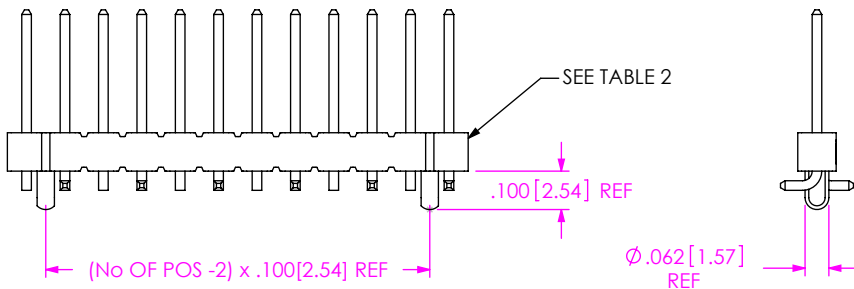

POSITION	USE BODY
-3	TSM-03-SV-A
-02 & -04 THRU -50	TSM-XX-SV-X

STYLE	OPTION	TUBE	PLUG
-01	----	PT-1-24-02-29 (SEE NOTE 3)	TP-24
-02, -04, -05	----	PT-1-24-02-29 (SEE NOTE 3)	TP-24
-01, -02, -04, -05	-LC, -A	PT-1-24-02-29 (SEE NOTE 3)	TP-24
-01, -04, -05	-P	PT-1-24-05-29	TP-03
-01, -04, -05	-LC-P, -A-P	PT-1-24-05-29	TP-03
-02	-P	PT-1-24-13-29	TP-03
-02	-LC-P, -A-P	PT-1-24-13-29	TP-03
-03	----	PT-1-24-10-29 (SEE NOTE 3)	TP-24
-03	-LC, -A	PT-1-24-10-29 (SEE NOTE 3)	TP-24
-03	-P	PT-1-24-14-29	TP-09
-03	-LC-P, -A-P	PT-1-24-14-29	TP-09

- NOTES:
 1. LOAD PARTS POSITION 1 FIRST IN SAME DIRECTION AS ARROW.
 2. NOTE DELETED
 3. PACKAGE POSITIONS -04 THRU -36.
 4. POLARIZED 4 POSITION PARTS WITHOUT PADS ARE TO BE LAYER PACKAGED OR PACKAGED IN TAPE AND REEL.

FIG 4
 TUBE PACKAGING

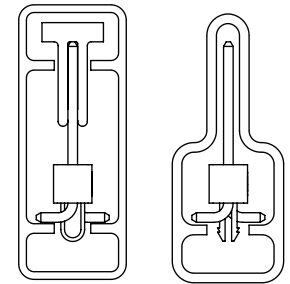
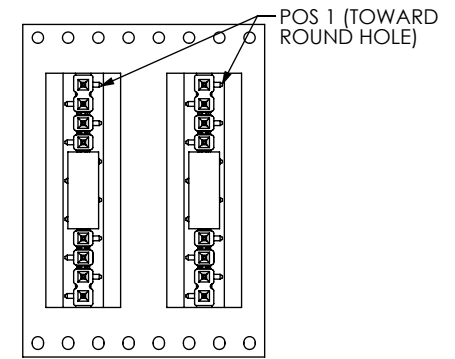
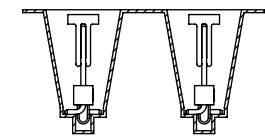

FIG 5
 -TR: TAPE & REEL PACKAGING OPTION



USER DIRECTION OF UN-REELING
 POCKET NOT DETAILED





F:\DWG\MISC\MKTG\TSM-1XX-XX-XXX-SV-XX-XXX-XX-MKT.SLDRW

DO NOT SCALE DRAWING SHEET SCALE: 2:1	<p>PROPRIETARY NOTE THIS DOCUMENT CONTAINS CONFIDENTIAL AND PROPRIETARY INFORMATION AND ALL DESIGN, MANUFACTURING, REPRODUCTION, USE, PATENT RIGHTS AND SALES RIGHTS ARE EXPRESSLY RESERVED BY SAMTEC, INC. THIS DOCUMENT SHALL NOT BE DISCLOSED, IN WHOLE OR PART, TO ANY UNAUTHORIZED PERSON OR ENTITY NOR REPRODUCED, TRANSFERRED OR INCORPORATED IN ANY OTHER PROJECT IN ANY MANNER WITHOUT THE EXPRESS WRITTEN CONSENT OF SAMTEC, INC.</p>	<p>520 PARK EAST BLVD, NEW ALBANY, IN 47150 PHONE: 812-944-6733 FAX: 812-948-5047 e-Mail info@SAMTEC.com code 55322</p>
	DESCRIPTION: SINGLE ROW .100 SMT ASSEMBLY	DWG. NO. TSM-1XX-XX-XXX-SV-XX-XXX-XX
	BY: DEAN P 8/21/2002	SHEET 2 OF 2

Looking for pricing, stock, or lifecycle information?

Click below to explore more details on WIN SOURCE:

-  [View TSM-103-01-L-SV-P-TR on WIN SOURCE](#)
-  [Samtec Inc. Information](#)

Optimize Your Supply Chain with WIN SOURCE Solutions

-  Global Sourcing Solution
-  Obsolete Management
-  Cost Control Management
-  Shortage Management
-  Alternative Solution
-  Excess Inventory Management