



## 0.4 GHz to 1.5 GHz QUADRATURE MODULATOR

### FEATURES

- P1dB of 7 dBm
- –156 dBm/Hz Noise Floor
- –150 dBm/Hz Noise at  $P_{OUT} = 0$  dBm
- Typical Unadjusted Carrier Suppression > 35 dBc at 1 GHz
- Typical Unadjusted Sideband Suppression > 40 dBc at 1 GHz
- Differential or Single-Ended I, Q Inputs
- Convenient Single-Ended LO Input
- Silicon Germanium Technology

### APPLICATIONS

- Cellular Base Transceiver Station Transmit Channel
- IF Sampling Applications
- TDMA: GSM, IS-136, EDGE/UWC-136
- CDMA: IS-95, UMTS, CDMA2000
- Wireless Local Loop
- Wireless LAN IEEE 802.11
- LMDS, MMDS
- Wideband Baseband Transceivers

### DESCRIPTION

The TRF3701 is an ultralow-noise direct quadrature modulator that is capable of converting complex input signals from baseband or IF directly up to RF. An internal analog combiner sums the real and imaginary components of the RF outputs. This combined output can feed the RF preamp directly at frequencies of up to 1.5 GHz. The modulator is implemented as a double-balanced mixer. An internal local oscillator (LO) phase splitter accommodates a single-ended LO input, eliminating the need for a costly external balun.

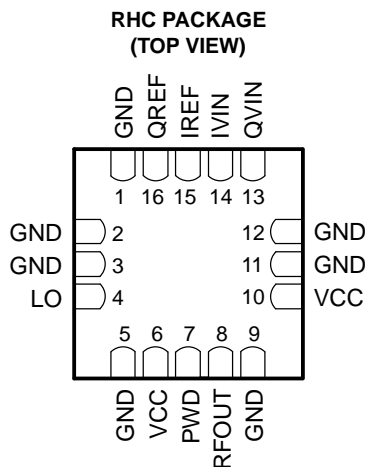

### AVAILABLE OPTIONS

$T_A$	4-mm × 4-mm 16-Pin RHC (QFN) Package
–40°C to 85°C	TRF3701IRHC
	TRF3701IRHCR (Tape and Reel)



Please be aware that an important notice concerning availability, standard warranty, and use in critical applications of Texas Instruments semiconductor products and disclaimers thereto appears at the end of this data sheet.

FUNCTIONAL BLOCK DIAGRAM

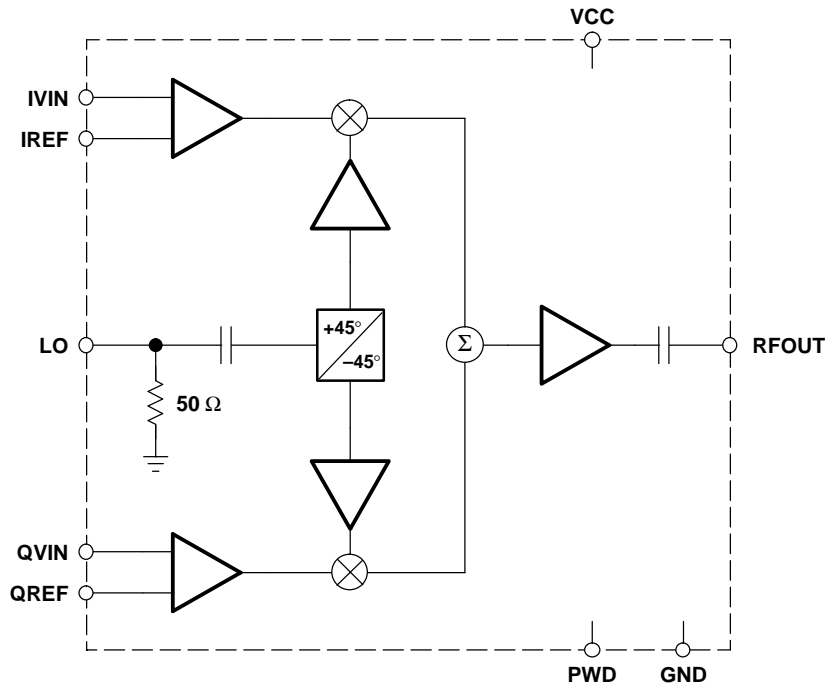

TERMINAL FUNCTIONS

TERMINAL		I/O	DESCRIPTION
NAME	NO.		
GND	1, 2, 3, 5, 9, 11, 12		Ground
IREF	15	I	In-phase (I) reference voltage/differential input
IVIN	14	I	In-phase (I) signal input
LO	4	I	Local oscillator input
PWD	7	I	Power down
QREF	16	I	Quadrature (Q) reference voltage/differential input
QVIN	13	I	Quadrature (Q) signal input
RFOUT	8	O	RF output
VCC	6, 10		Supply voltage

ABSOLUTE MAXIMUM RATINGS

over operating free-air temperature range (unless otherwise noted)<sup>(1)(2)</sup>

V <sub>CC</sub>	Supply voltage range	-0.5 V to 6 V
	LO input power level	10 dBm
	Baseband input voltage level (single-ended)	3 V <sub>p-p</sub>
T <sub>A</sub>	Operating free-air temperature range	-40°C to 85°C
	Lead temperature for 10 seconds	260°C

- (1) Stresses beyond those listed under "absolute maximum ratings" may cause permanent damage to the device. These are stress ratings only, and functional operation of the device at these or any other conditions beyond those indicated under "recommended operating conditions" is not implied. Exposure to absolute-maximum-rated conditions for extended periods may affect device reliability.
- (2) Measured with respect to ground

**RECOMMENDED OPERATING CONDITIONS**

	MIN	NOM	MAX	UNIT
<b>Supplies and References</b>				
V <sub>CC</sub> Analog supply voltage	4.5	5	5.5	V
V <sub>CM</sub> (IVIN, QVIN, IREF, QREF input common-mode dc voltage)	3.7			V
<b>Local Oscillator Input (LO)</b>				
Input frequency	400		1500	MHz
Power level (measured into 50 Ω)	–6	0	6	dBm
<b>Signal Inputs (IVIN, QVIN)</b>				
Input bandwidth	700			MHz

**ELECTRICAL CHARACTERISTICS**

Over recommended operating conditions, V<sub>CC</sub> = 5 V, V<sub>CM</sub> = 3.7 V, f<sub>LO</sub> = 942.5 MHz at 0 dBm, T<sub>A</sub> = 25°C (unless otherwise noted)

PARAMETER	TEST CONDITIONS	MIN	TYP	MAX	UNIT
<b>Power Supply</b>					
I <sub>CC</sub> Total supply current	V(PWD) = 5 V	145			mA
	V(PWD) = 0 V	13			
Power-down input impedance		11			kΩ
Turnon time		120			ns
Turnoff time		20			ns
<b>Local Oscillator (LO) Input</b>					
Input impedance		40 + j4.8			Ω
<b>Signal Inputs (IVIN, QVIN, IREF, QREF)</b>					
Input bias current	V(IVIN) = V(IREF) = V(QVIN) = V(QREF) = V <sub>CM</sub> = 3.7 V	16			μA
Input impedance	Single-ended input	250			kΩ
	Differential input	125			

## RF OUTPUT PERFORMANCE

Over recommended operating conditions,  $V_{CC} = 5\text{ V}$ ,  $V_{CM} = 3.7\text{ V}$ ,  $f_{LO} = 942.5\text{ MHz}$  at 0 dBm,  $T_A = 25^\circ\text{C}$  (unless otherwise noted)<sup>(1)</sup>

PARAMETER		TEST CONDITIONS	MIN	TYP	MAX	UNIT
<b>Single and Two-Tone Specifications</b>						
Output power			-3.5	-1		dBm
Second baseband harmonic (USB or LSB) <sup>(3)</sup>		I, Q <sup>(2)</sup> = 1 Vp-p, $f_{BB} = 928\text{ kHz}$		-50	-45	dBc
Third baseband harmonic (USB or LSB) <sup>(3)</sup>				-61	-55	dBc
IMD <sub>3</sub>		I, Q <sup>(2)</sup> = 1 Vp-p (two-tone signal, $f_{BB1} = 928\text{ kHz}$ , $f_{BB2} = 992\text{ kHz}$ )		-55	-45	dBc
P1dB (output compression point)				6.5		dBm
NSD	Noise spectral density	I, Q <sup>(4)</sup> = VCM = 3.7 VDC		-156		dBm/Hz
		6-MHz offset from carrier, $P_{out} = -10\text{ dBm}$ , over temperature		-153	-151 <sup>(5)</sup>	
		6-MHz offset from carrier, $P_{out} = -5\text{ dBm}$ , over temperature		-152	-150 <sup>(5)</sup>	
		6-MHz offset from carrier, $P_{out} = 0\text{ dBm}$ , over temperature		-150	-148 <sup>(5)</sup>	
RFOUT pin impedance				26 + j3		$\Omega$
Carrier suppression		I, Q <sup>(2)</sup> = 1 Vp-p, $f_{BB} = 928\text{ kHz}$ , unadjusted	30	35		dBc
		I, Q <sup>(2)</sup> = 1 Vp-p, $f_{BB} = 928\text{ kHz}$ , optimized		55		
		I, Q <sup>(2)</sup> = 1 Vp-p, $f_{BB} = 928\text{ kHz}$ , over temperature		35		
Sideband suppression		I, Q <sup>(2)</sup> = 1 Vp-p, $f_{BB} = 928\text{ kHz}$ , unadjusted	37	50		dBc
		I, Q <sup>(2)</sup> = 1 Vp-p, $f_{BB} = 928\text{ kHz}$ , optimized		55		
		I, Q <sup>(2)</sup> = 1 Vp-p, $f_{BB} = 928\text{ kHz}$ , over temperature		38		

(1) Baseband inputs are differential; equivalent performance is attained by using single-ended drive.

(2) I, Q = 1 Vp-p implies that the magnitude of the signal at each input pin IVIN, IREF, QVIN, QREF is equal to 500 mVp-p.

(3) USB = upper sideband. LSB = lower sideband.

(4) All input pins tied to VCM

(5) Maximum noise values are assured by statistical characterization only, not production testing. The values specified are over the entire temperature range,  $T_A = -40^\circ\text{C}$  to  $85^\circ\text{C}$ .

## DEFINITIONS OF SELECTED SPECIFICATIONS

### Unadjusted Carrier Suppression

This specification measures the amount by which the local oscillator component is attenuated in the output spectrum of the modulator relative to the carrier. It is assumed that the baseband inputs delivered to the pins of the TRF3701 are perfectly matched to have the same dc offset (VCM). This includes all four baseband inputs: IVIN, QVIN, IREF and QREF. Unadjusted carrier suppression is measured in dBc.

### Adjusted (Optimized) Carrier Suppression

This differs from the unadjusted suppression number in that the dc offsets of the baseband inputs are iteratively adjusted around their theoretical value of VCM in order to yield the maximum suppression of the LO component in the output spectrum. Adjusted carrier suppression is measured in dBc.

### Unadjusted Sideband Suppression

This specification measures the amount by which the unwanted sideband of the input signal is attenuated in the output of the modulator, relative to the wanted sideband. It is assumed that the baseband inputs delivered to the modulator input pins are perfectly matched in amplitude and are exactly  $90^\circ$  out of phase. Unadjusted sideband suppression is measured in dBc.

## **DEFINITIONS OF SELECTED SPECIFICATIONS (continued)**

### **Adjusted (Optimized) Sideband Suppression**

This differs from the unadjusted sideband suppression in that the baseband inputs are iteratively adjusted around their theoretical values to maximize the amount of sideband suppression. Adjusted sideband suppression is measured in dBc.

### **Suppressions Over Temperature**

This specification assumes that the user has gone through the optimization process for the suppression in question, and set the optimal settings for the I, Q inputs at room temperature. This specification then measures the suppression when temperature conditions change after the initial calibration is done.

TYPICAL CHARACTERISTICS

For all the performance plots in this section, the following conditions were used, unless otherwise noted:  $T_A = -40^\circ\text{C}$  to  $85^\circ\text{C}$ ,  $V_{CC} = 5\text{ V}$ ,  $V_{CM} = 3.7\text{ V}$ ,  $f_{LO} = 942.5\text{ MHz}$  at  $P_{LO} = 0\text{ dBm}$ , I and Q inputs driven differentially at a frequency of  $50\text{ kHz}$  for an output power level  $P_{out} = 0\text{ dBm}$ . In the case of optimized suppressions, the point of optimization is noted and is always at nominal conditions and room temperature. A level of  $>50\text{ dBc}$  is assumed to be optimized.

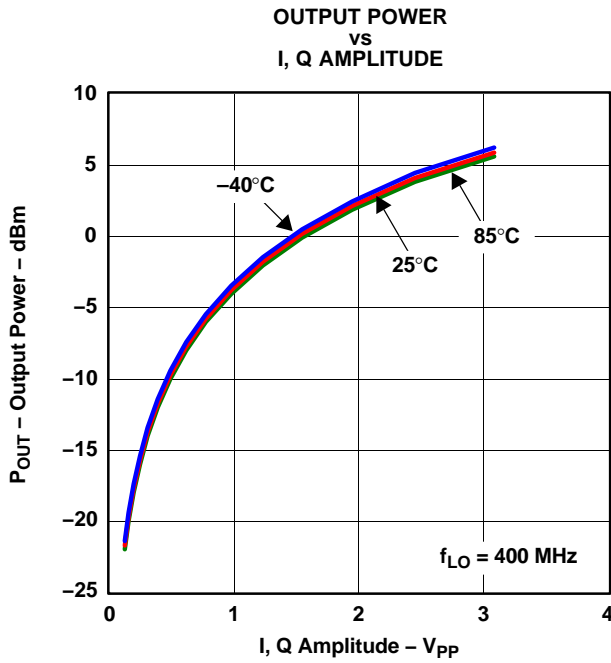

Figure 1.

G001

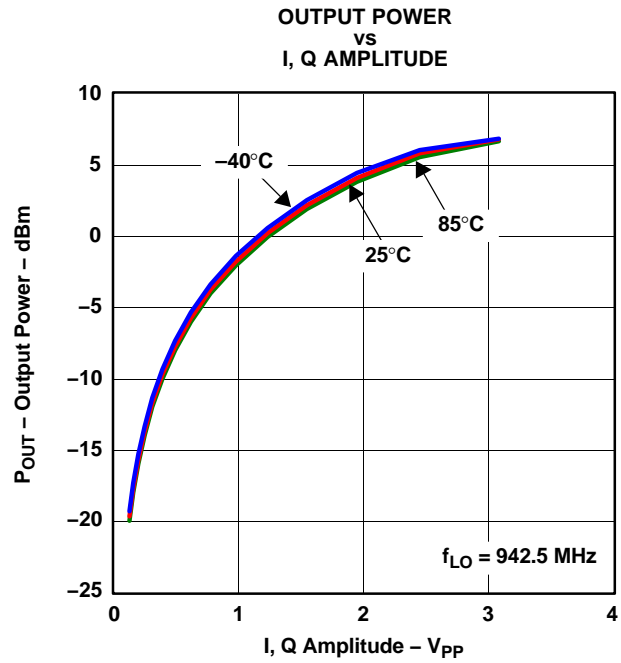

Figure 2.

G002

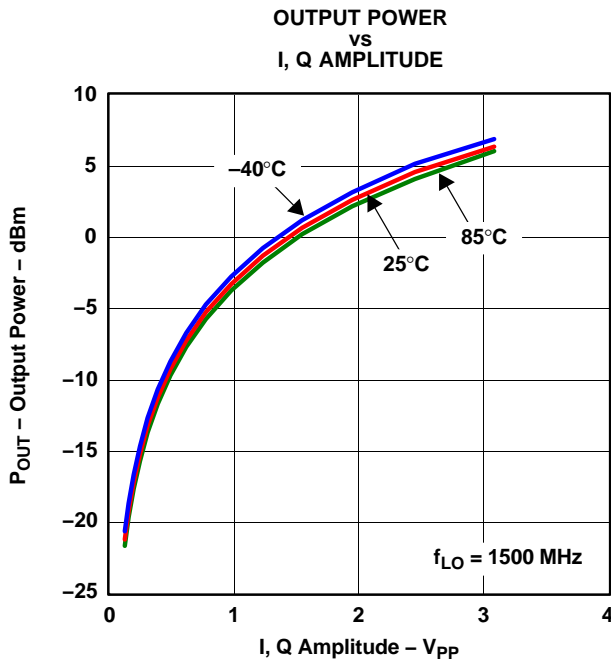

Figure 3.

G003

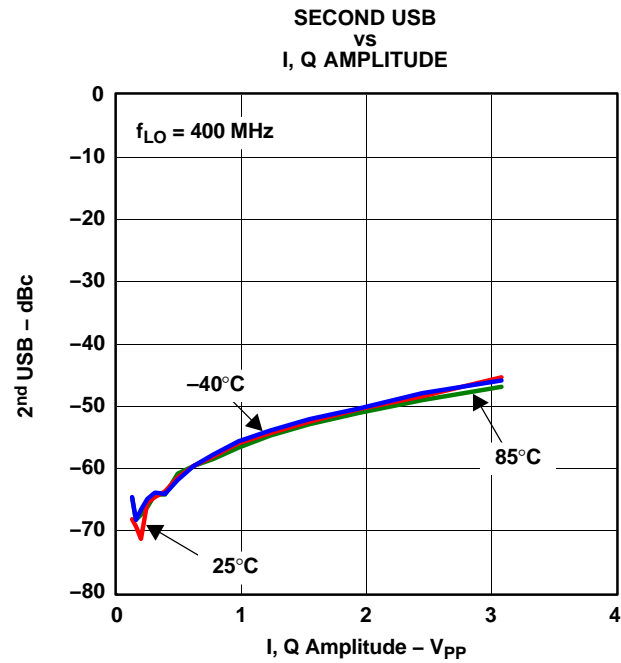

Figure 4.

G004

TYPICAL CHARACTERISTICS (continued)

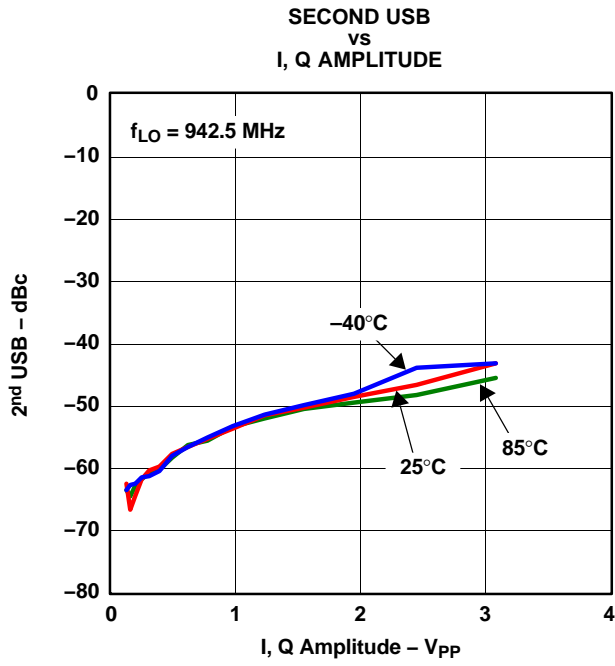

Figure 5.

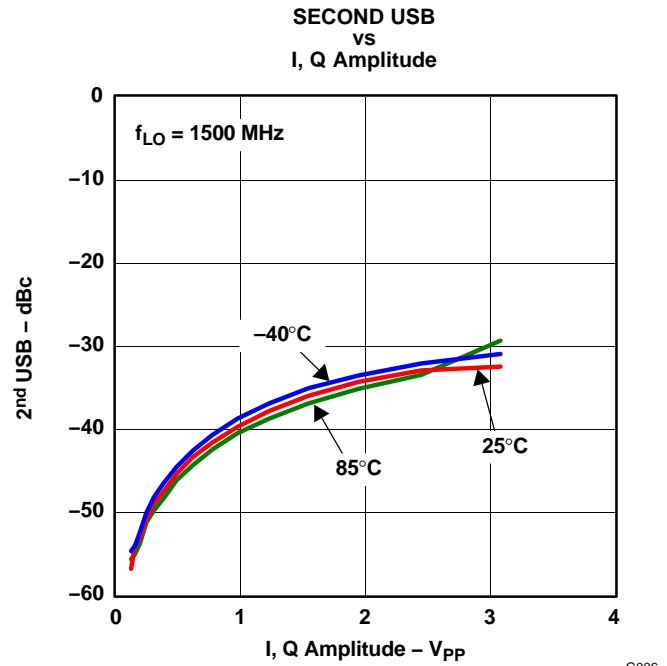

Figure 6.

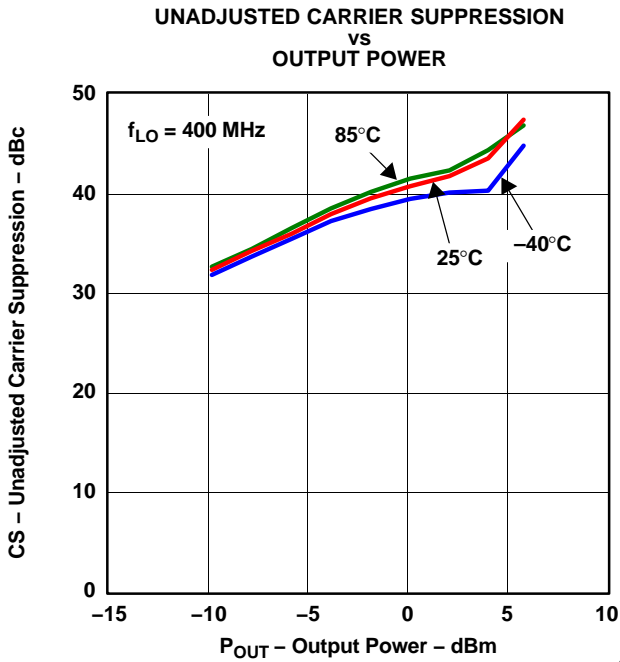

Figure 7.

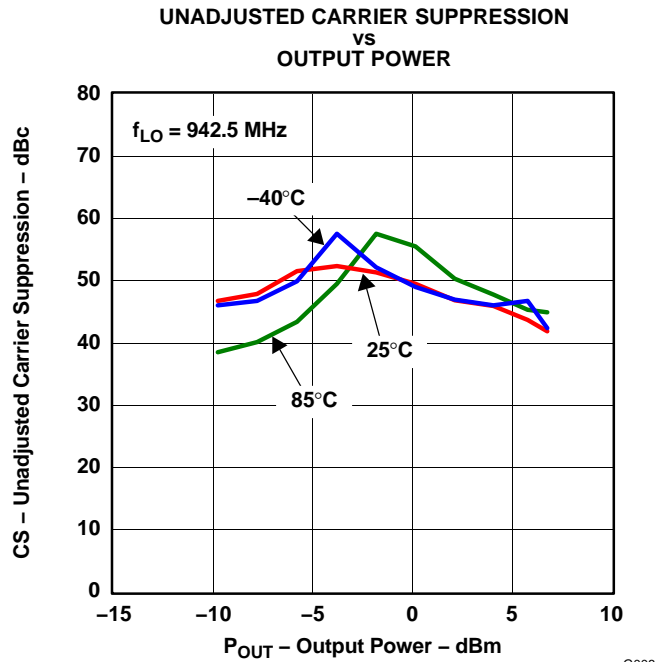

Figure 8.

TYPICAL CHARACTERISTICS (continued)

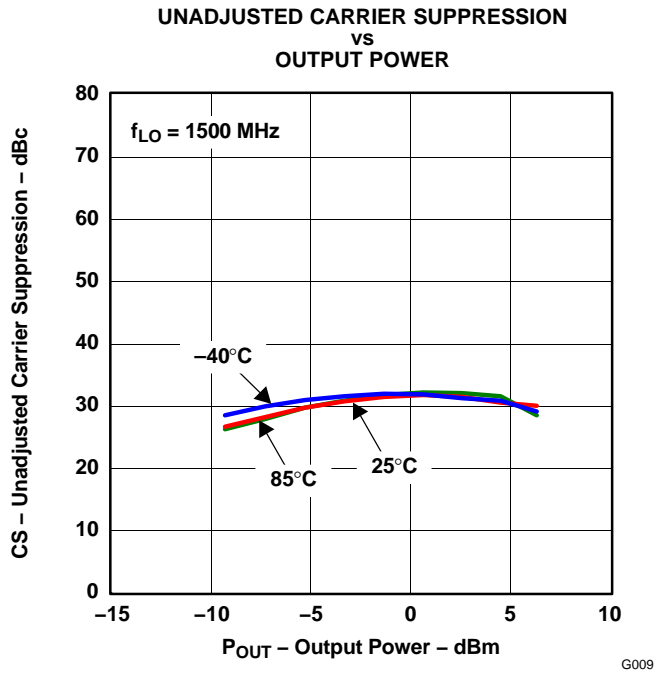

Figure 9.

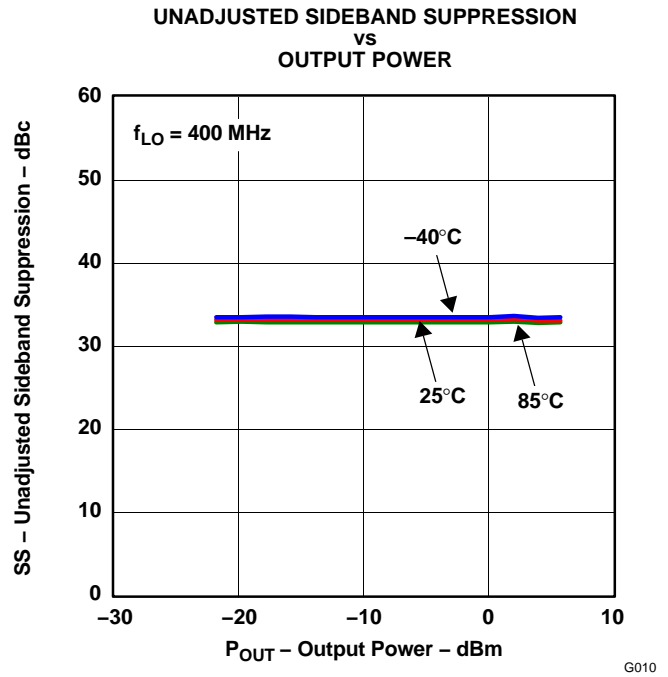

Figure 10.

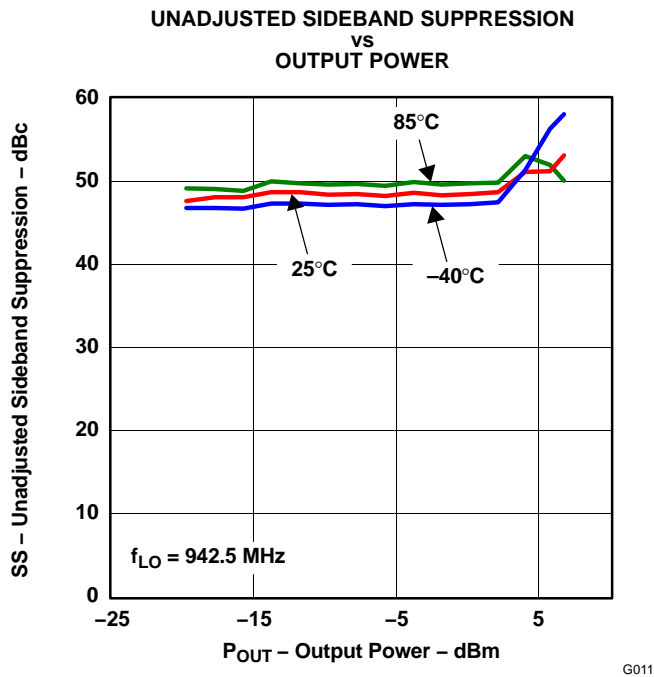

Figure 11.

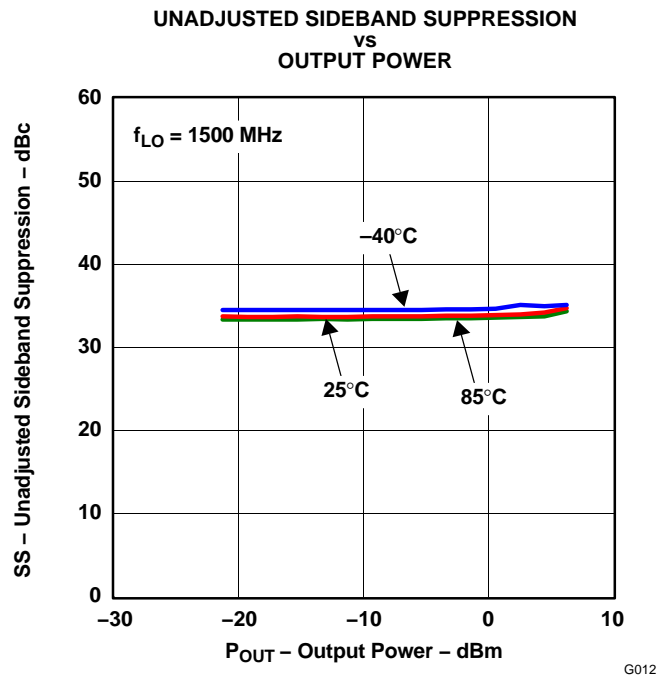

Figure 12.

**TYPICAL CHARACTERISTICS (continued)**

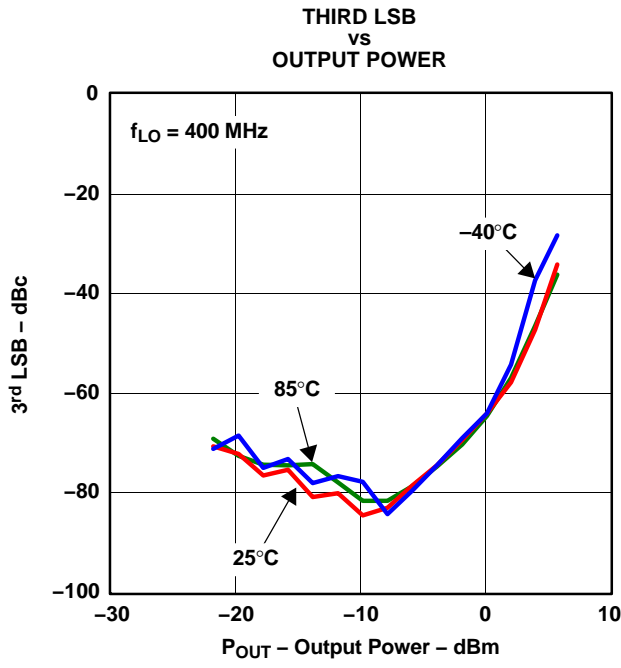

Figure 13.

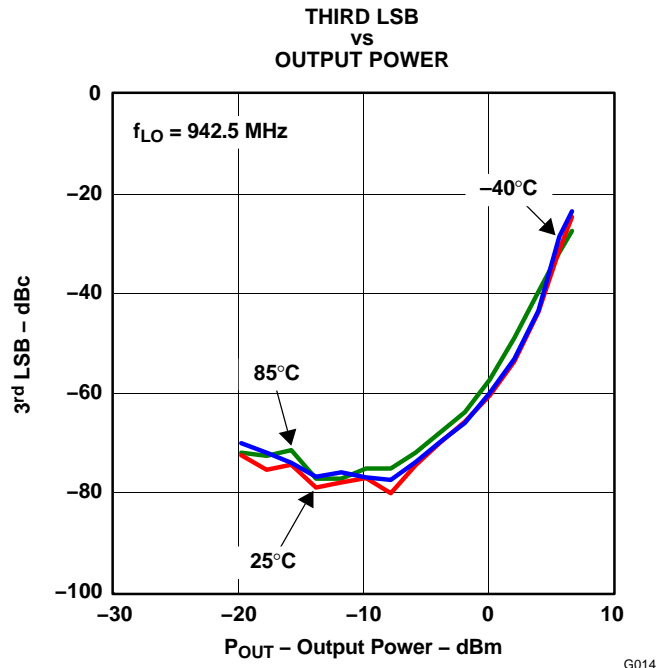

Figure 14.

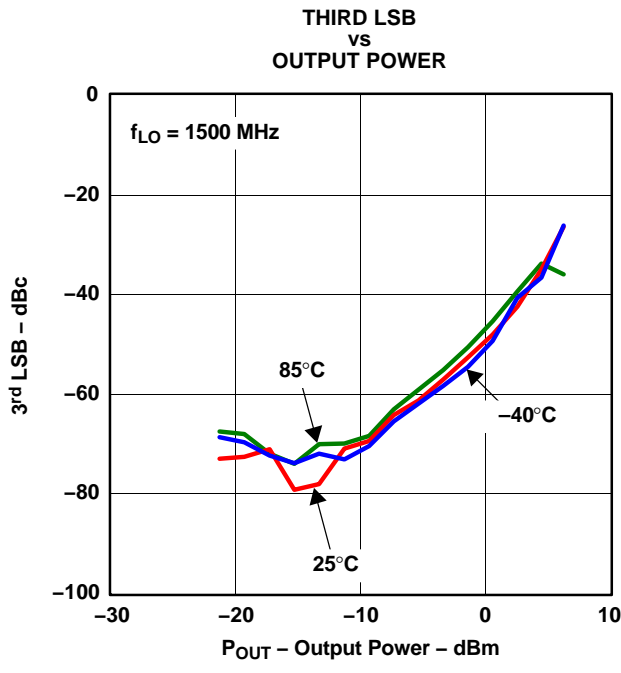

Figure 15.

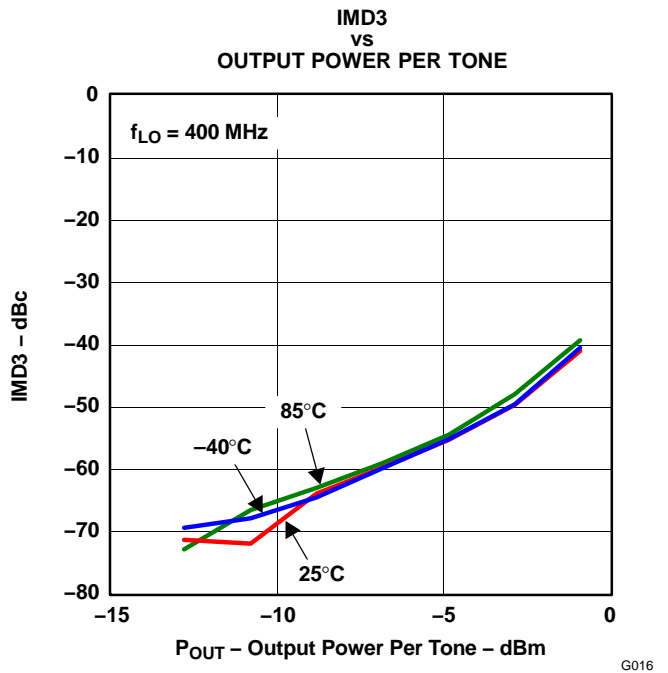

Figure 16.

TYPICAL CHARACTERISTICS (continued)

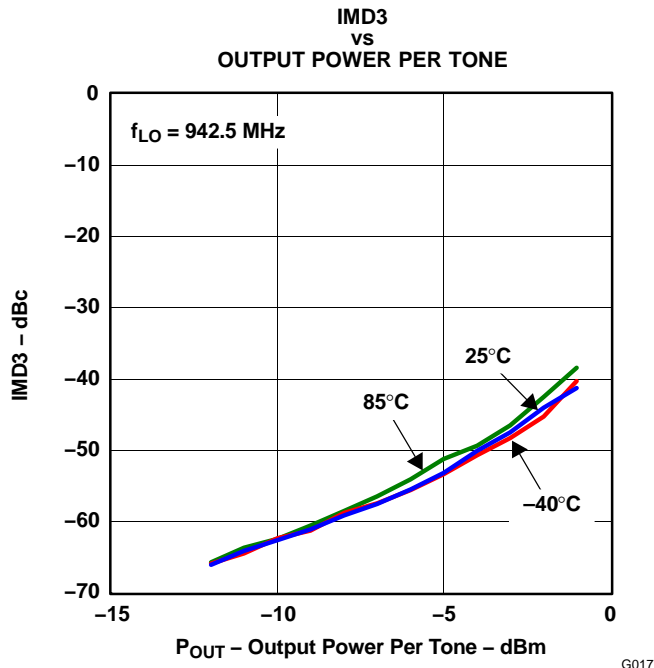

Figure 17.

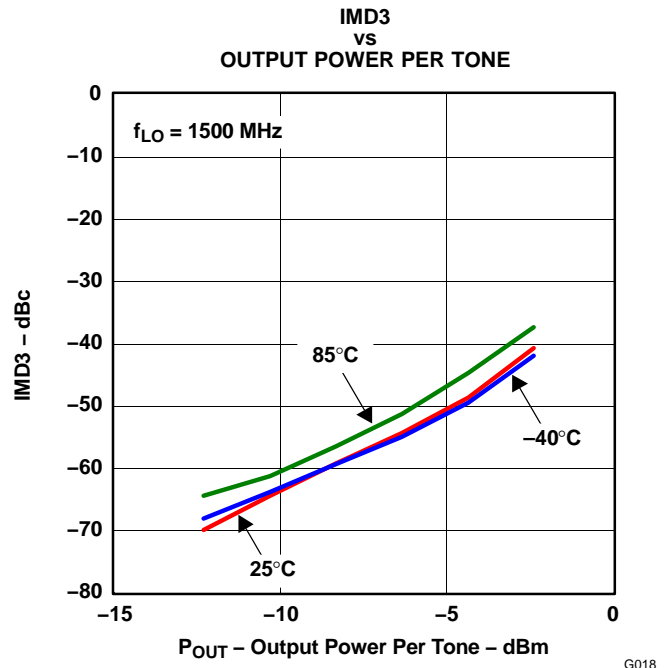

Figure 18.

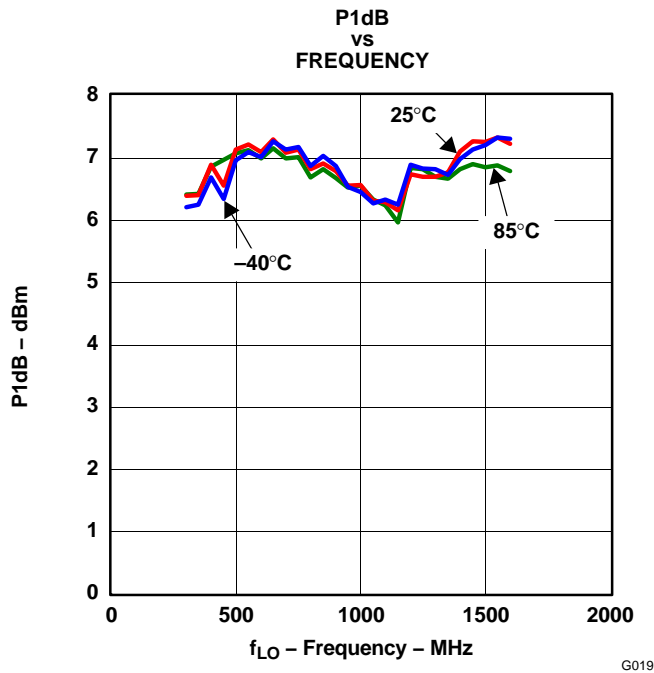

Figure 19.

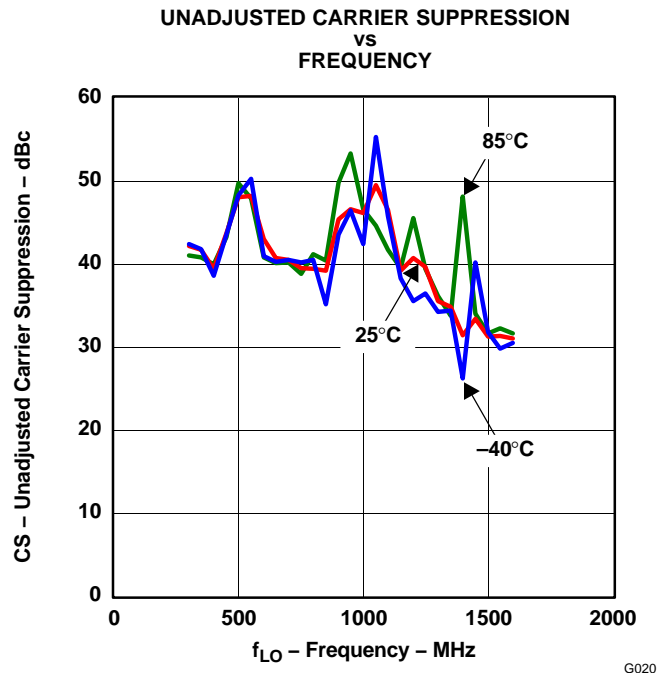
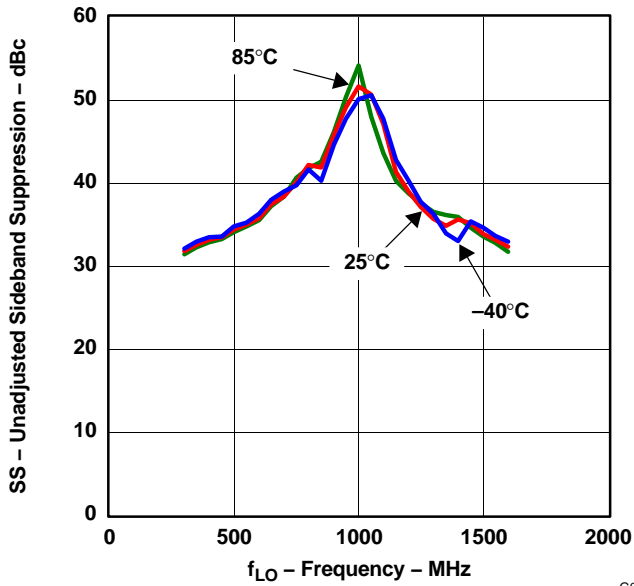

Figure 20.

**TYPICAL CHARACTERISTICS (continued)**

**UNADJUSTED SIDEBAND SUPPRESSION  
VS  
FREQUENCY**



G021

Figure 21.

**OUTPUT POWER FLATNESS  
VS  
FREQUENCY (P<sub>OUT</sub> = 0, -10 dBm NOMINAL)**

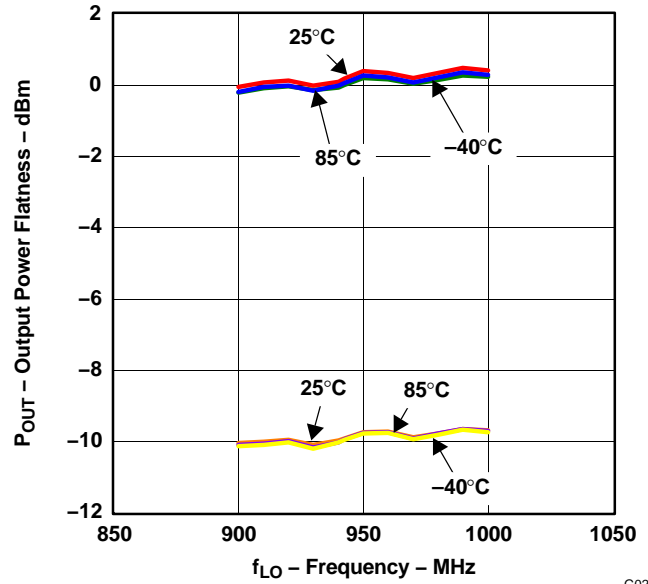

G022

Figure 22.

**SECOND USB  
VS  
FREQUENCY**

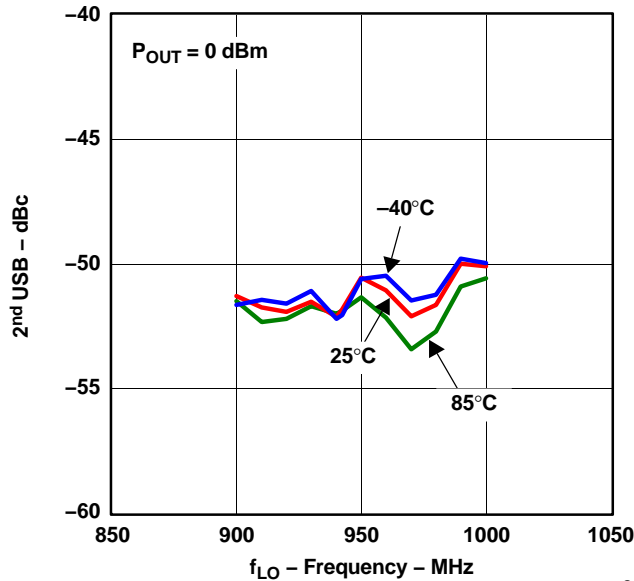

G023

Figure 23.

**THIRD LSB  
VS  
FREQUENCY**

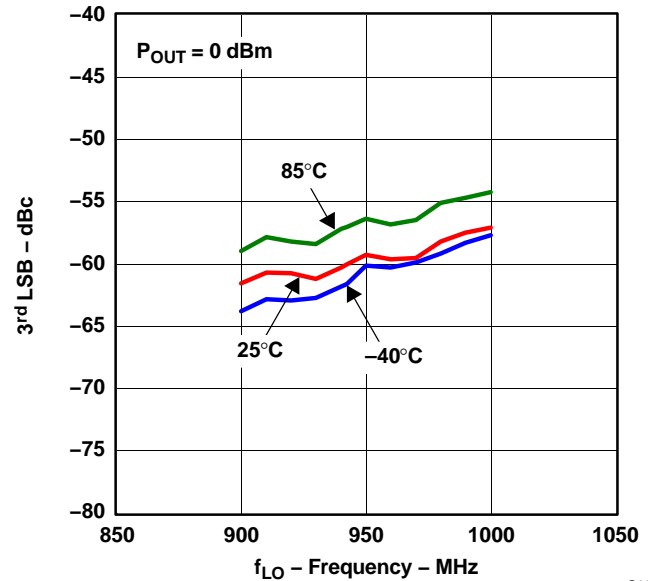

G024

Figure 24.

TYPICAL CHARACTERISTICS (continued)

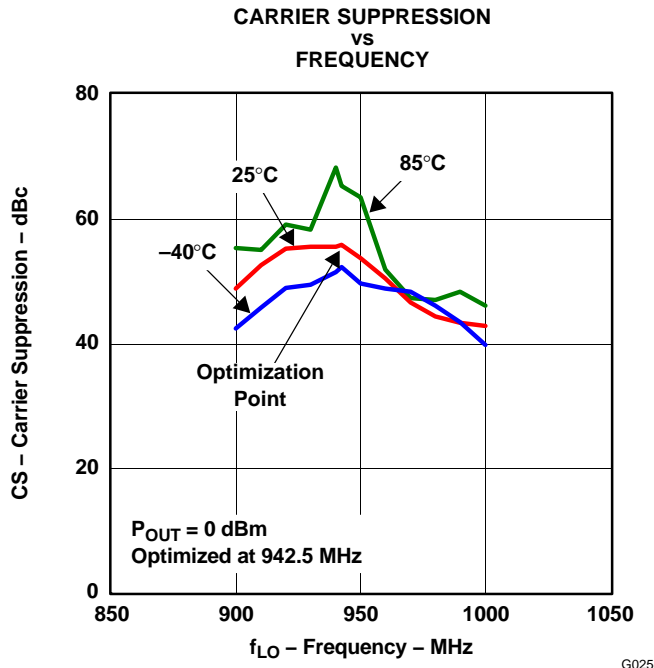

Figure 25.

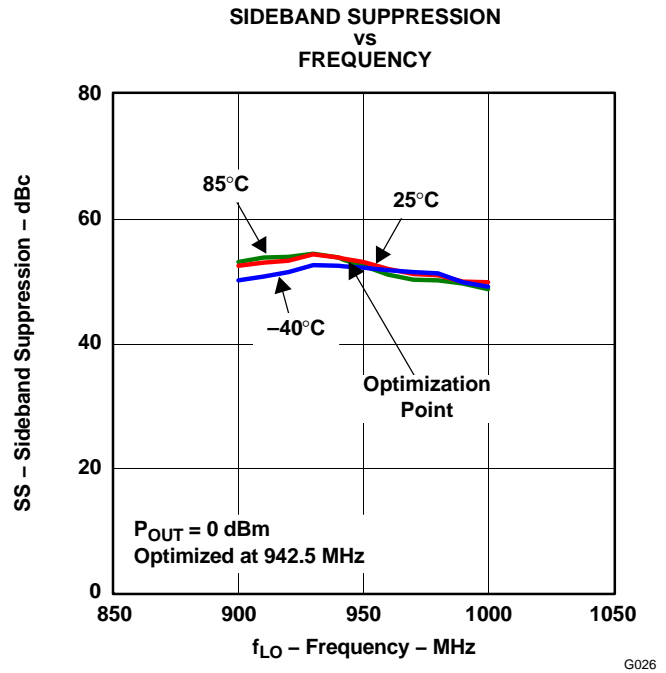

Figure 26.

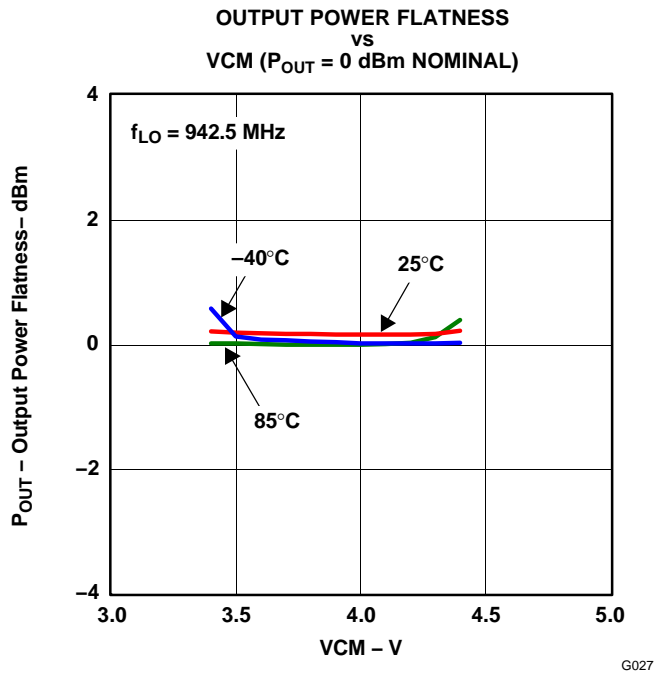

Figure 27.

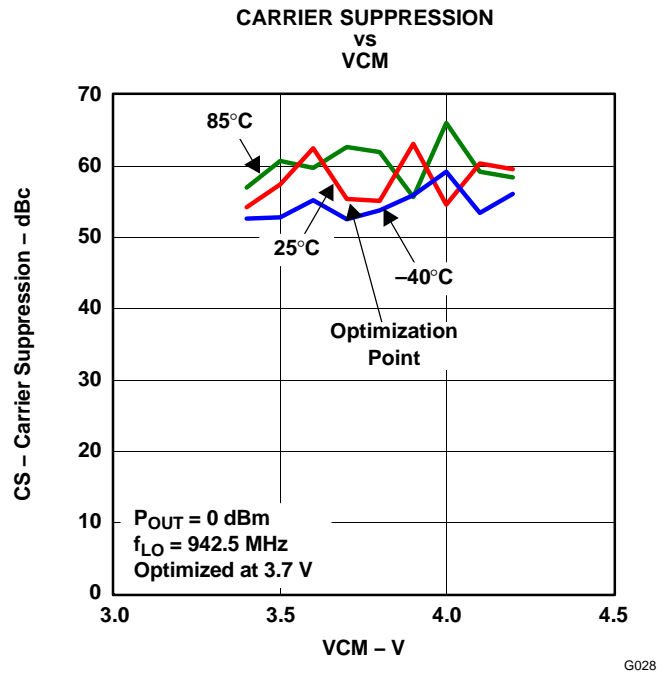

Figure 28.

**TYPICAL CHARACTERISTICS (continued)**

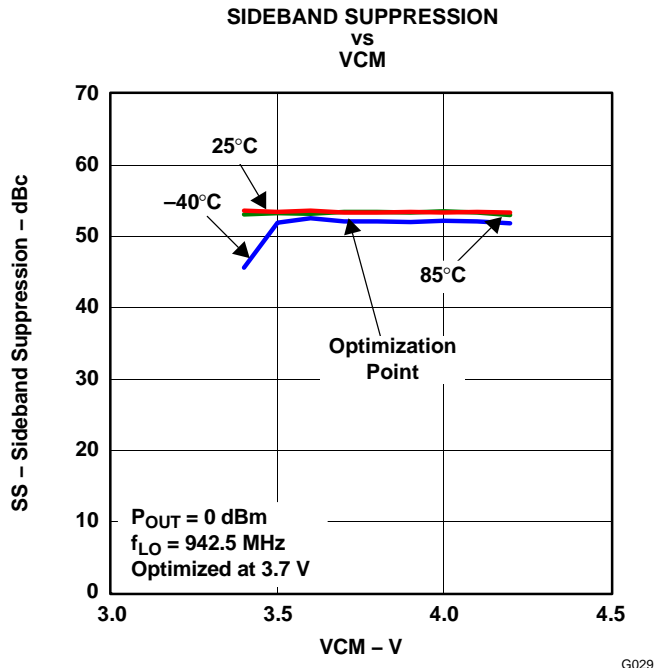

Figure 29.

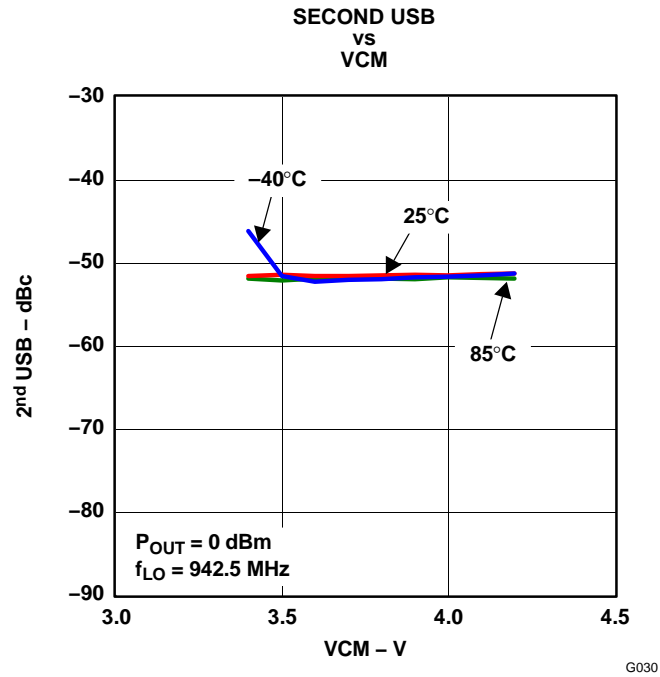

Figure 30.

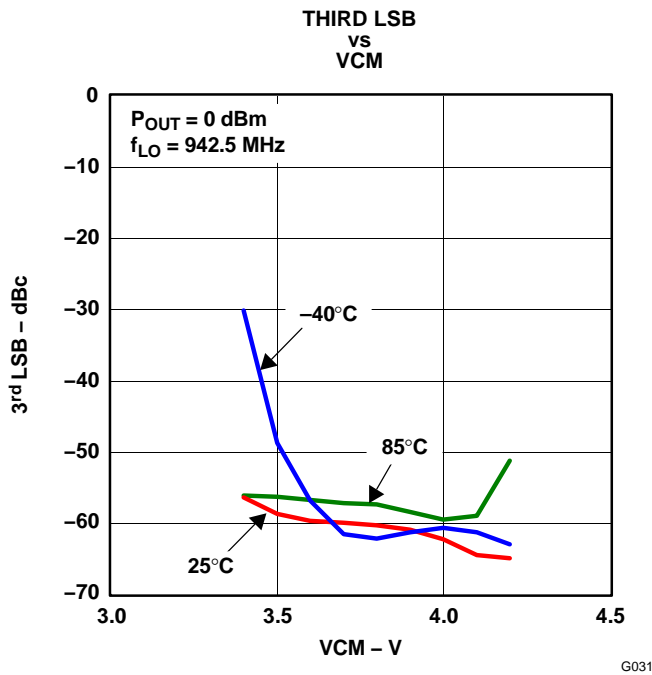

Figure 31.

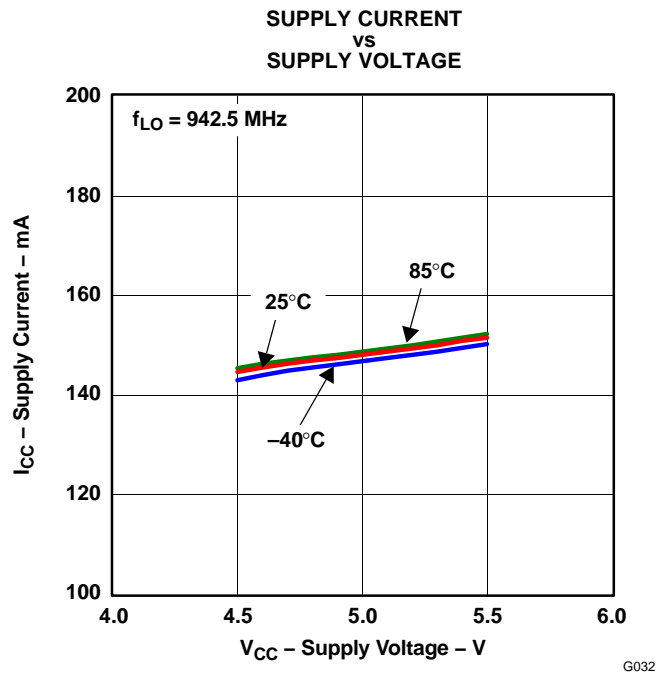

Figure 32.

TYPICAL CHARACTERISTICS (continued)

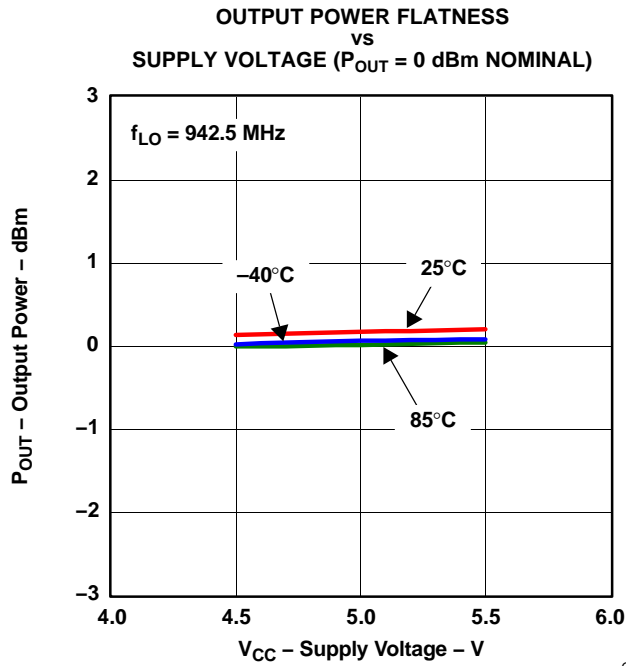

Figure 33.

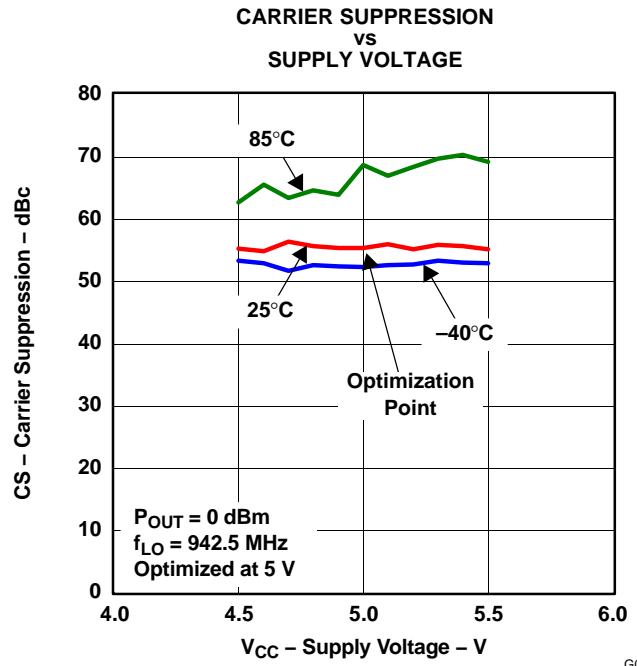

Figure 34.

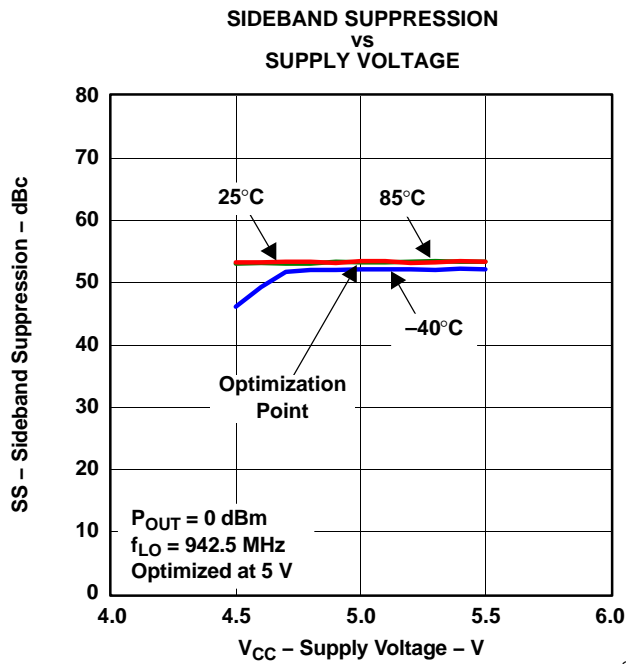

Figure 35.

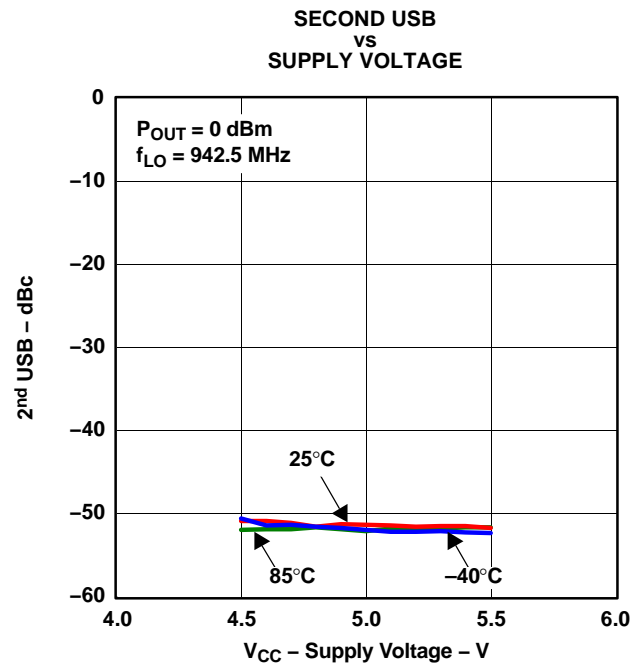

Figure 36.

**TYPICAL CHARACTERISTICS (continued)**

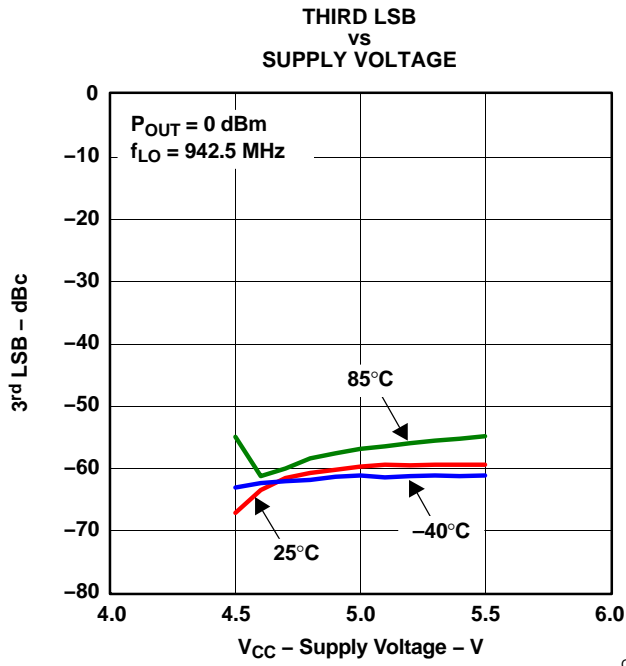

Figure 37.

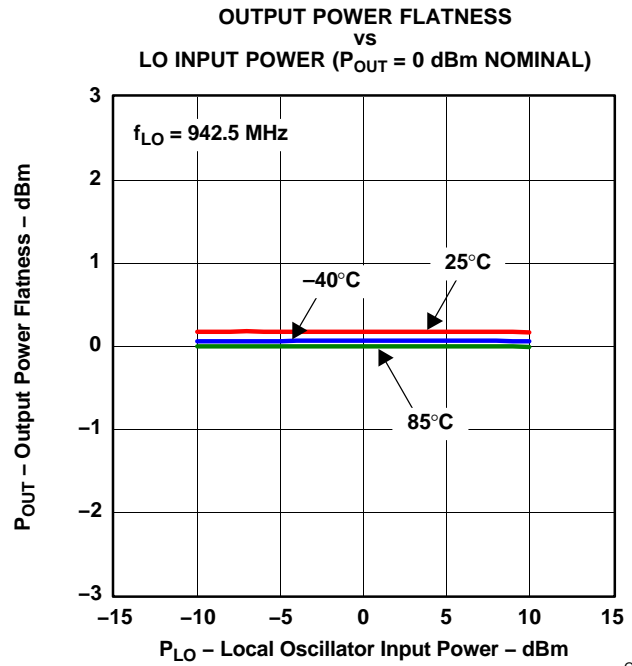

Figure 38.

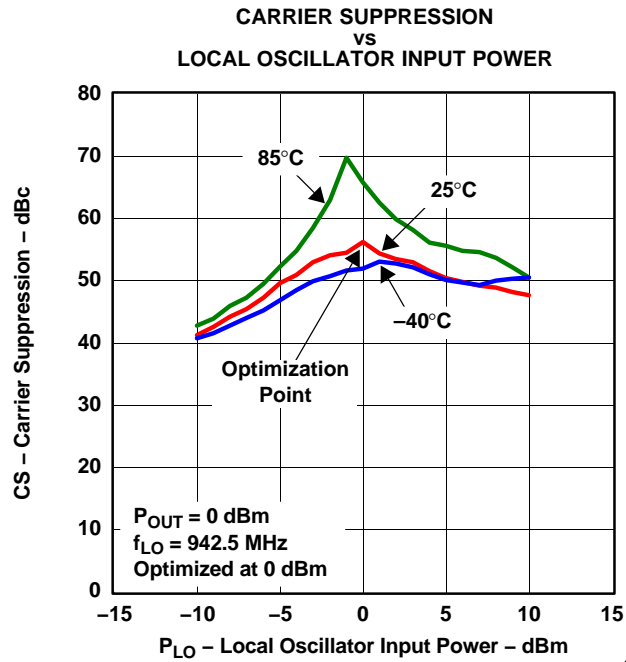

Figure 39.

Table 1. RFOUT and LO Pin Impedance

Frequency (MHz)	Z (RFOUT Pin)	Z (LO Pin)
100	8.59 - j 130.2	33.95 - j 106.93
200	7.12 - j 61.22	29.54 - j 52.57
300	8.52 - j 36.37	28.65 - j 31.83
400	10.5 - j 23.72	29.371 - j 19.33
500	12.82 - j 15.51	30.78 - j 11.42
600	15.26 - j 9.33	32.64 - j 6.06
700	187.1 - j 4.77	34.99 - j 1.65
800	20.8 - j 1.2	36.55 + j 1.65
900	24.2 + j 2.0	38.52 + j 3.98
1000	28.7 + j 4.9	40.29 + j 5.92
1100	32.35 + j 6.61	42.21 + j 6.98
1200	37.15 + j 6.88	44.09 + j 7.55
1300	40.55 + j 6.64	45.7 + j 7.96
1400	43.76 + j 6.4	47 + j 7.76
1500	46.6 + j 6.03	48.28 + j 7.39

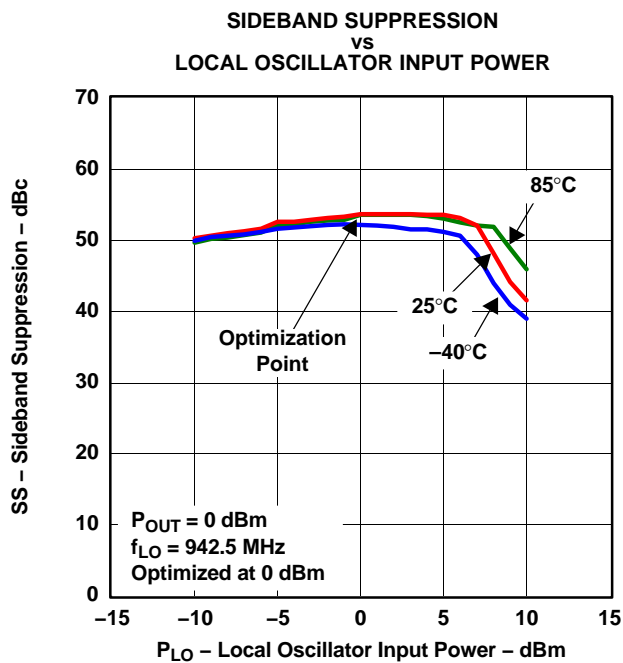

Figure 40.

G040

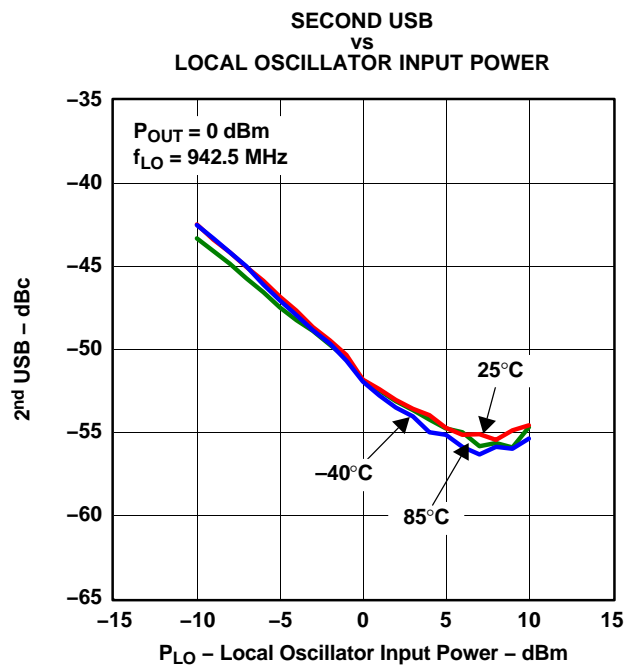

Figure 41.

G041

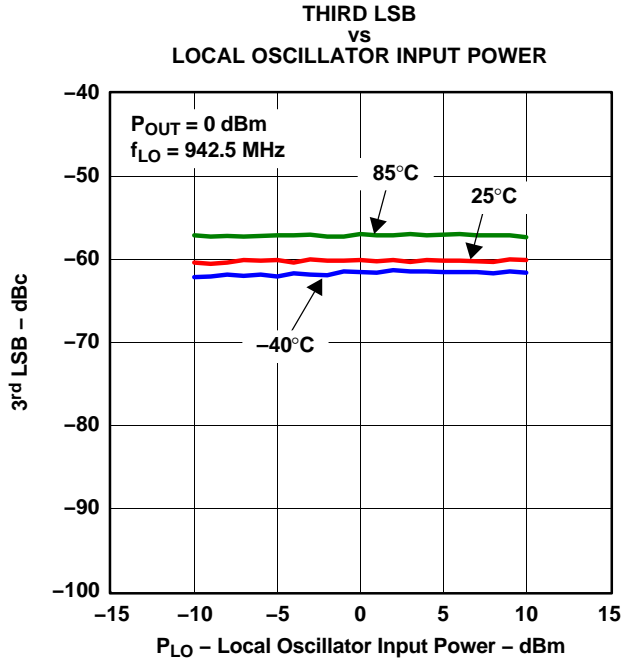

Figure 42.

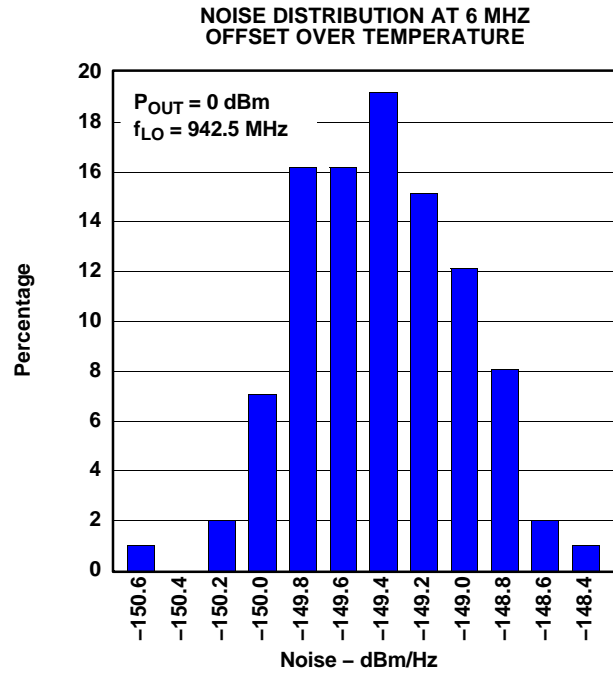

Figure 43.

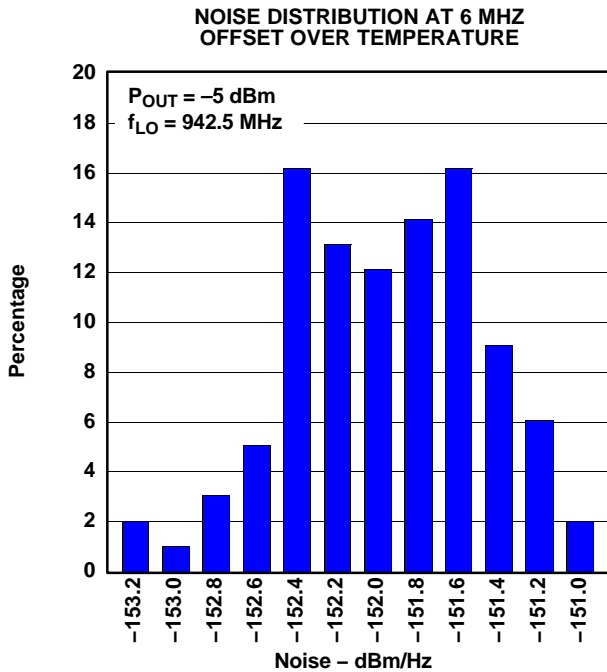

Figure 44.

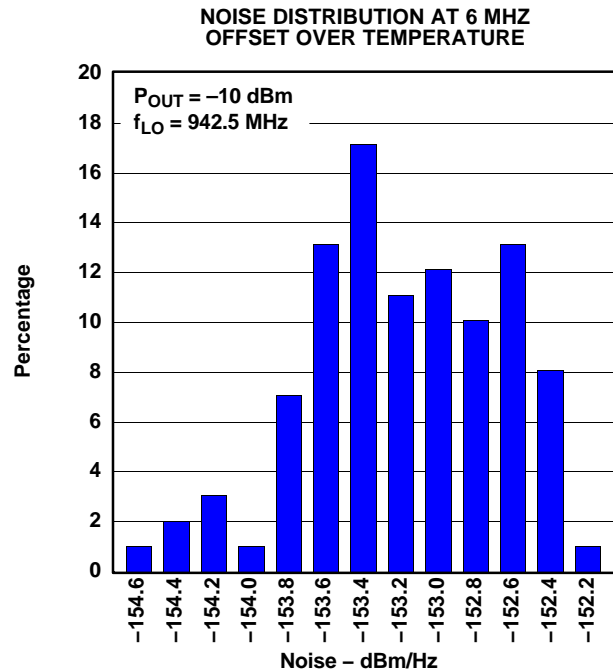

Figure 45.

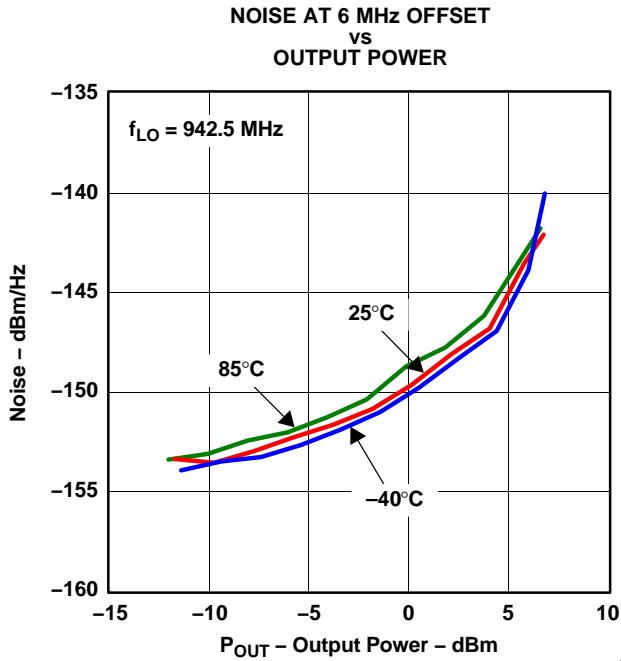

Figure 46.

G046

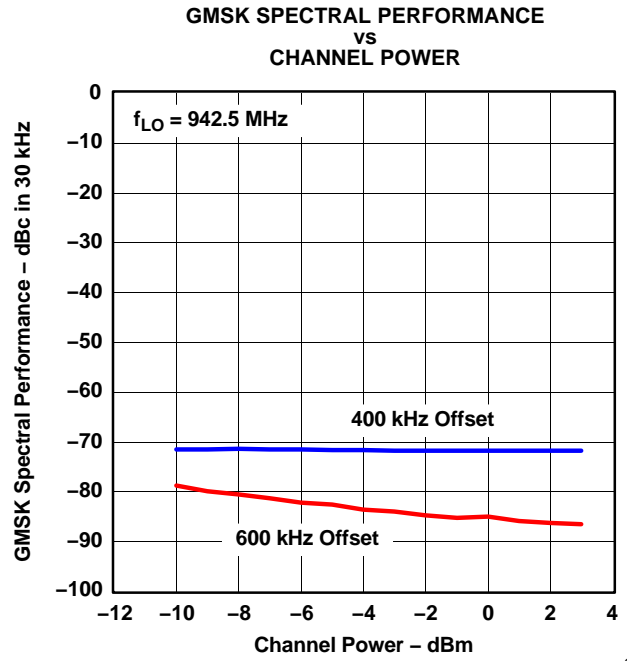

Figure 47.

G047

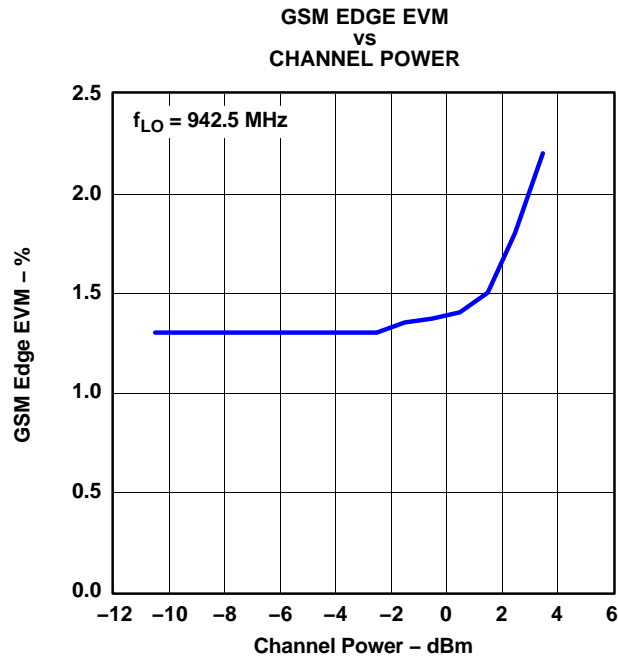

Figure 48.

G048

## THEORY OF OPERATION

The TRF3701 employs a double-balanced mixer architecture in implementing the direct I, Q upconversion. The I, Q inputs can be driven single-endedly or differentially, with comparable performance in both cases. The common mode level (VCM) of the four inputs (IVIN, IREF, QVIN, QREF) is typically set to 3.7 V and needs to be driven externally. These inputs go through a set of differential amplifiers and through a V-I converter feed the double-balanced mixers. The AC-coupled LO input to the device goes through a phase splitter to provide the in-phase and quadrature signals that in turn drive the mixers. The outputs of the mixers are then summed, converted to single-ended signals, and amplified before they are fed to the output port RFOUT. The output of the TRF3701 is ac-coupled and can drive 50-Ω loads.

## EQUIVALENT CIRCUITS

Figure 49 through Figure 52 show equivalent schematics for the main inputs and outputs of the device.

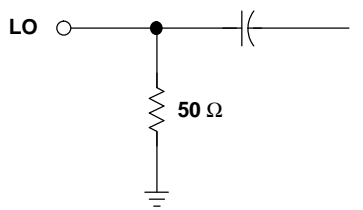

S0001-01

Figure 49. LO Equivalent Input Circuit

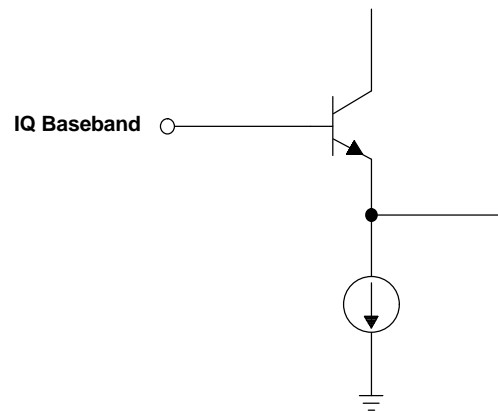

S0002-01

Figure 50. IVIN, QVIN, IREF, QREF Equivalent Circuit

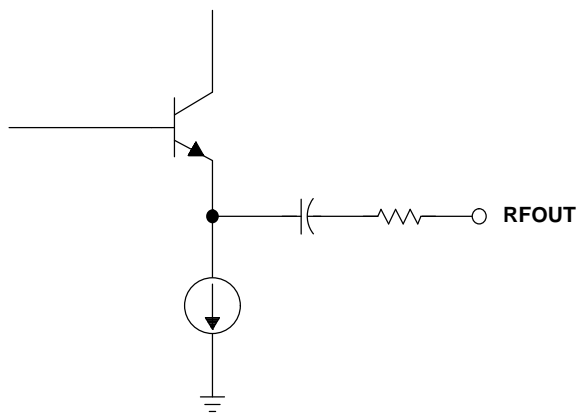

S0003-01

Figure 51. RFOUT Equivalent Circuit

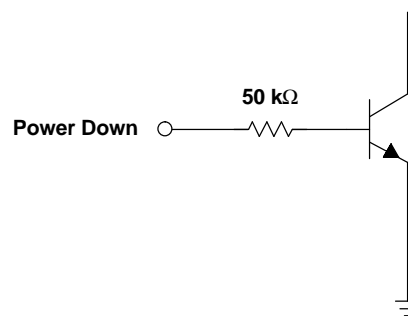

S0004-01

Figure 52. Power-Down (PWD) Equivalent Circuit

## APPLICATION INFORMATION

### DRIVING THE I, Q INPUTS

There are several ways to drive the four baseband inputs of the TRF3701 to the required amplitude and dc offset. The optimal configuration depends on the end application requirements and the signal levels desired by the designer.

The TRF3701 is by design a differential part, meaning that ideally the user should provide fully complementary signals. However, similar performance in every respect can be achieved if the user only has single-ended signals available. In this case, the IREF and QREF pins just need to have the VCM dc offset applied.

#### Implementing a Single-to-Differential Conversion for the I, Q inputs

In case differential I, Q signals are desired but not available, the THS4503 family of wideband, low-distortion, fully differential amplifiers can be used to provide a convenient way of performing this conversion. Even if differential signals are available, the THS4503 can provide gain in case a higher voltage swing is required. Besides featuring high bandwidth and high linearity, the THS4503 also provides a convenient way of applying the VCM to all four inputs to the modulator through the VOVM pin (pin 2). The user can further adjust the dc levels for optimum carrier suppression by injecting extra dc at the inputs to the operational amplifier, or by individually adding it to the four outputs. Figure 53 shows a typical implementation of the THS4503 as a driver for the TRF3701. Gain can be easily incorporated in the loop by adjusting the feedback resistors appropriately. For more details, see the THS4503 data sheet at [www.ti.com](http://www.ti.com).

**APPLICATION INFORMATION (continued)**

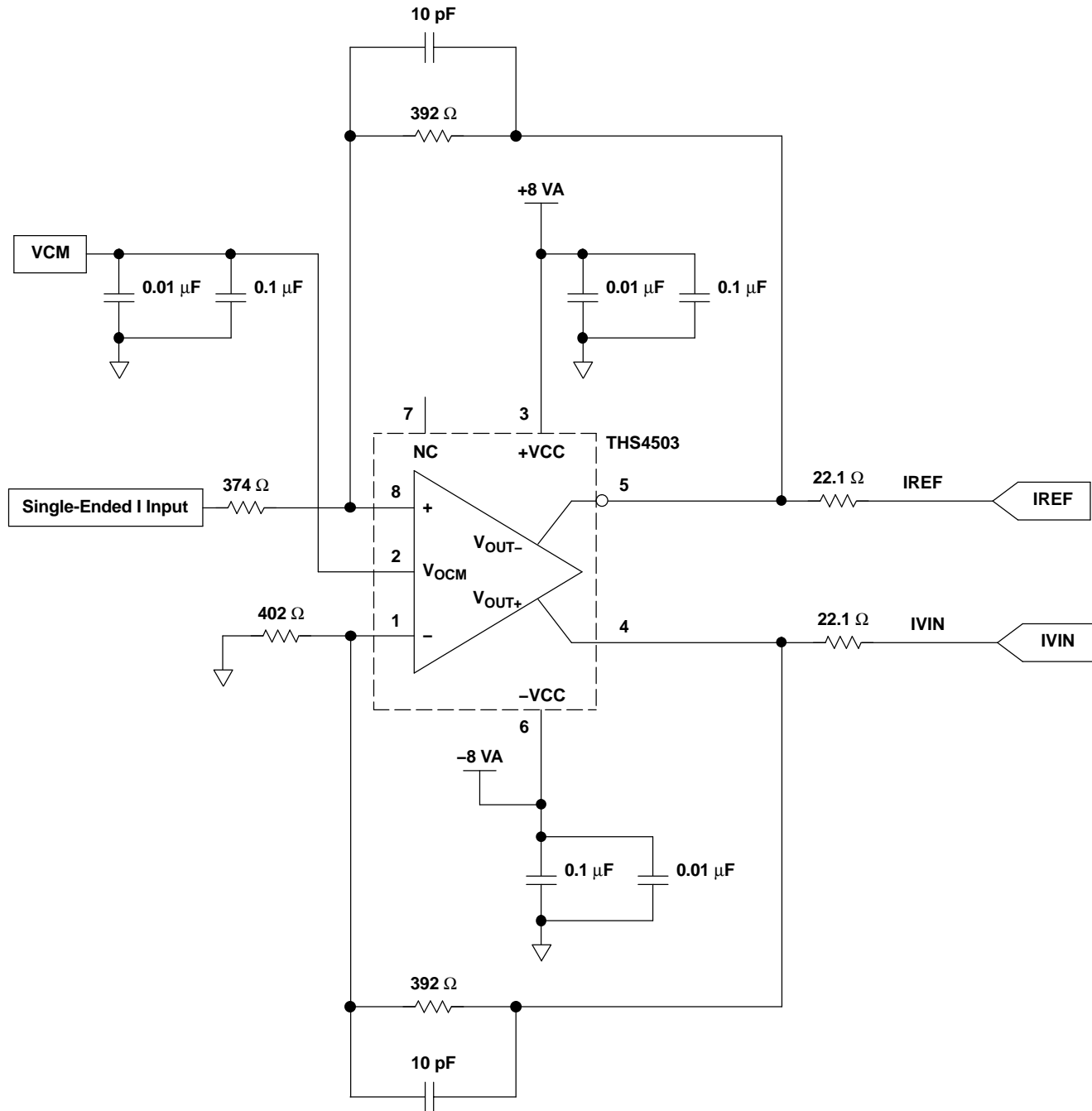

S0005-02

**Figure 53. Using the THS4503 to Condition the Baseband Inputs to the TRF3701 (I Channel Shown)**

**DRIVING THE LOCAL OSCILLATOR INPUT**

The LO pin is internally terminated to 50 Ω, thus enabling easy interface to the LO source without the need for external impedance matching. The power level of the LO signal should be in the range of –6 to 6 dBm. For characterization purposes, a power level of 0 dBm was chosen. An ideal way of driving the LO input of the TRF3701 is by using the TRF3750, an ultralow-phase-noise integer-N PLL from Texas Instruments. Combining the TRF3750 with an external VCO can complete the loop and provide a flexible, convenient and cost-effective

## APPLICATION INFORMATION (continued)

solution for the local oscillator of the transmitter. Figure 54 shows a typical application for the LO driver network that incorporates the TRF3750 integer-N PLL synthesizer into the design. Depending on the VCO output and the amount of signal loss, an optional gain stage may be added to the output of the VCO before it is applied to the TRF3701 LO input.

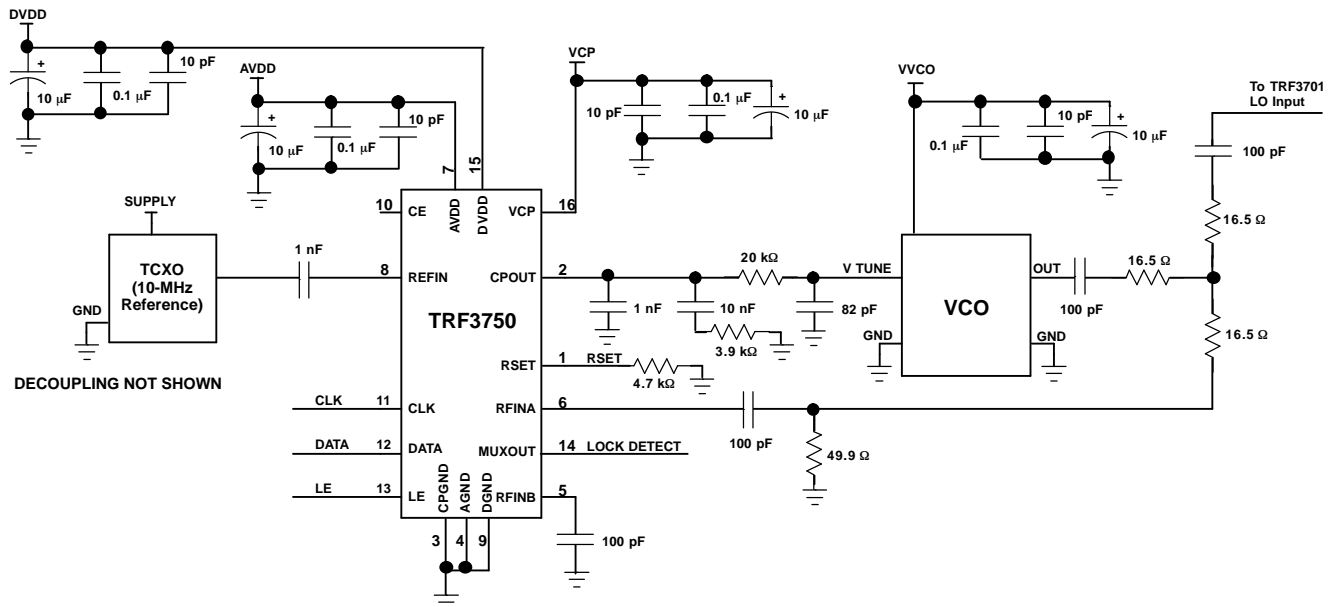

Figure 54. Typical Application Circuit for Generating the LO Signal for the TRF3701 Modulator

## PCB LAYOUT CONSIDERATIONS

The TRF3701 is a high-performance RF device; hence, care should be taken in the layout of the PCB in order to ensure optimum performance. Proper decoupling with low ESR capacitors is needed for the VCC supplies (pins 6 and 10). Typical values used are in the order of 1 pF in parallel to 0.1 µF, with the lower-valued capacitors placed closer to the device pins. In addition, a larger tank capacitor in the order of 10 µF should be placed on the supply line as layout permits. At least a 4-layer board is recommended for the PCB. If possible, a solid ground plane and a ground pour is also recommended, as is a power plane for the supplies. Because the balance of the four I, Q inputs to the modulator can be critical to device performance, care should be taken to ensure that the trace runs for all four inputs are equidistant. In the case of single-ended drive of the I, Q inputs, the two unused pins IREF and QREF are fed with the VCM dc voltage only, and should be decoupled with a 0.1-µF capacitor (or smaller). The LO input trace should be minimized in length and have controlled impedance of 50 Ω. No external matching components are needed because there is an internal 50-Ω termination. The RFOUT pin should also have a relatively small trace to minimize parasitics and coupling, and should also be controlled to 50 Ω. An impedance-matching network can be used to optimize power transfer, but is not critical. All the results shown in the data sheet were taken with no impedance matching network used (RFOUT directly driving an external 50-Ω load).

The exposed thermal and ground pad on the bottom of the TRF3701 should be soldered to ground to ensure optimum electrical and thermal performance. The landing pattern on the PCB should include a solid pad and 4 thermal vias. These vias typically have 1,2-mm pitch and 0,3-mm diameter. The vias can be arranged in a 2×2 array. The thermal pad on the PCB should be at least 1.65×1.65 mm.

## IMPLEMENTING A DIRECT UPCONVERSION TRANSMITTER USING A TI CommsDAC

The TRF3701 is ideal for implementing a direct upconversion transmitter, where the input I, Q data can originate from an ASIC or a DAC. Texas Instruments' line of digital-to-analog converters (DAC) is ideally suited for interfacing to the TRF3701. Such DACs include, among others, the DAC290x series, DAC5672, and DAC5686.

**APPLICATION INFORMATION (continued)**

This section illustrates the use of the DAC5686, which offers a unique set of features that make interfacing to the TRF3701 easy and convenient. The DAC5686 is a 16-bit, 500 MSPS,  $2\times-16\times$  interpolating dual-channel DAC, and it features I, Q adjustments for optimal interface to the TRF3701. User-selectable, 11-bit offset and 12-bit gain adjustments can optimize the carrier and sideband suppression of the modulator, resulting in enhanced performance and relaxed filtering requirements at RF. The preferred mode of operation of the DAC5686 for direct interface with the TRF3701 at baseband is the dual-DAC mode. The user also has the flexibility of selecting any one of the four possible complex spectral bands to be fed into the TRF3701. For details on the available modes and programming, see the DAC5686 data sheet available at www.ti.com.

Figure 55 shows the DAC5686 in dual-DAC mode, which is best-suited for zero-IF interface to the TRF3701. In this mode, a seamless, passive interface between the DAC output and the input to the modulator is used, so that no extra components are needed between the two devices. The optimum dc offset level for the inputs to the TRF3701 (VCM) is approximately 3.7 V. The output of the DAC should be centered around 3.3 V or less (depending on signal swing), in order to ensure that its output compliance limits are not exceeded. The resistive network shown in Figure 55 allows for this dc offset transition while still providing a dc path between the DAC output and the modulator. This ensures that the dc offset adjustments on the DAC5686 can still be applied to optimize the carrier suppression at the modulator output. The combination of the DAC5686 and the TRF3701 provides a unique signal-chain solution with state-of-the-art performance for wireless infrastructure applications.

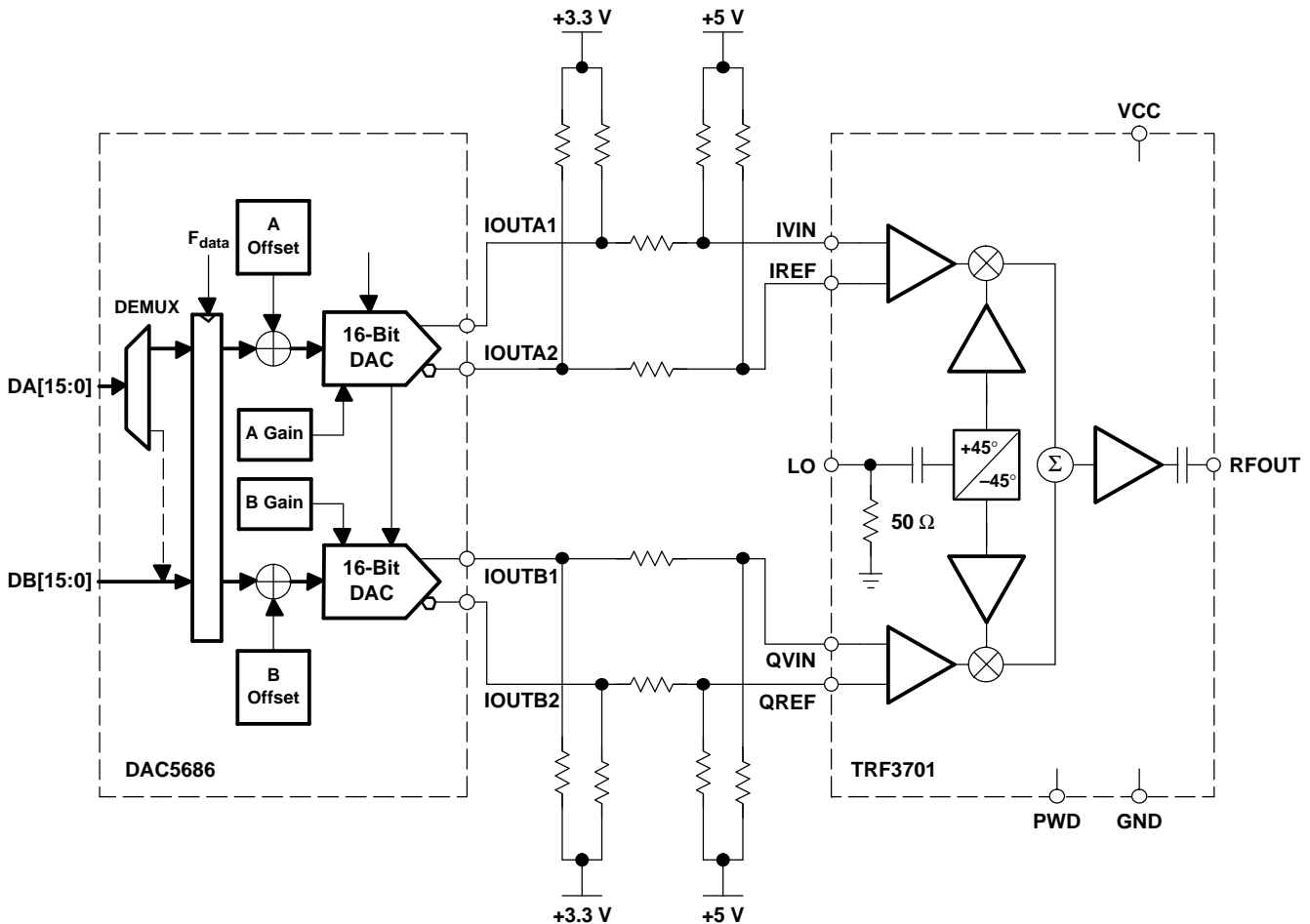
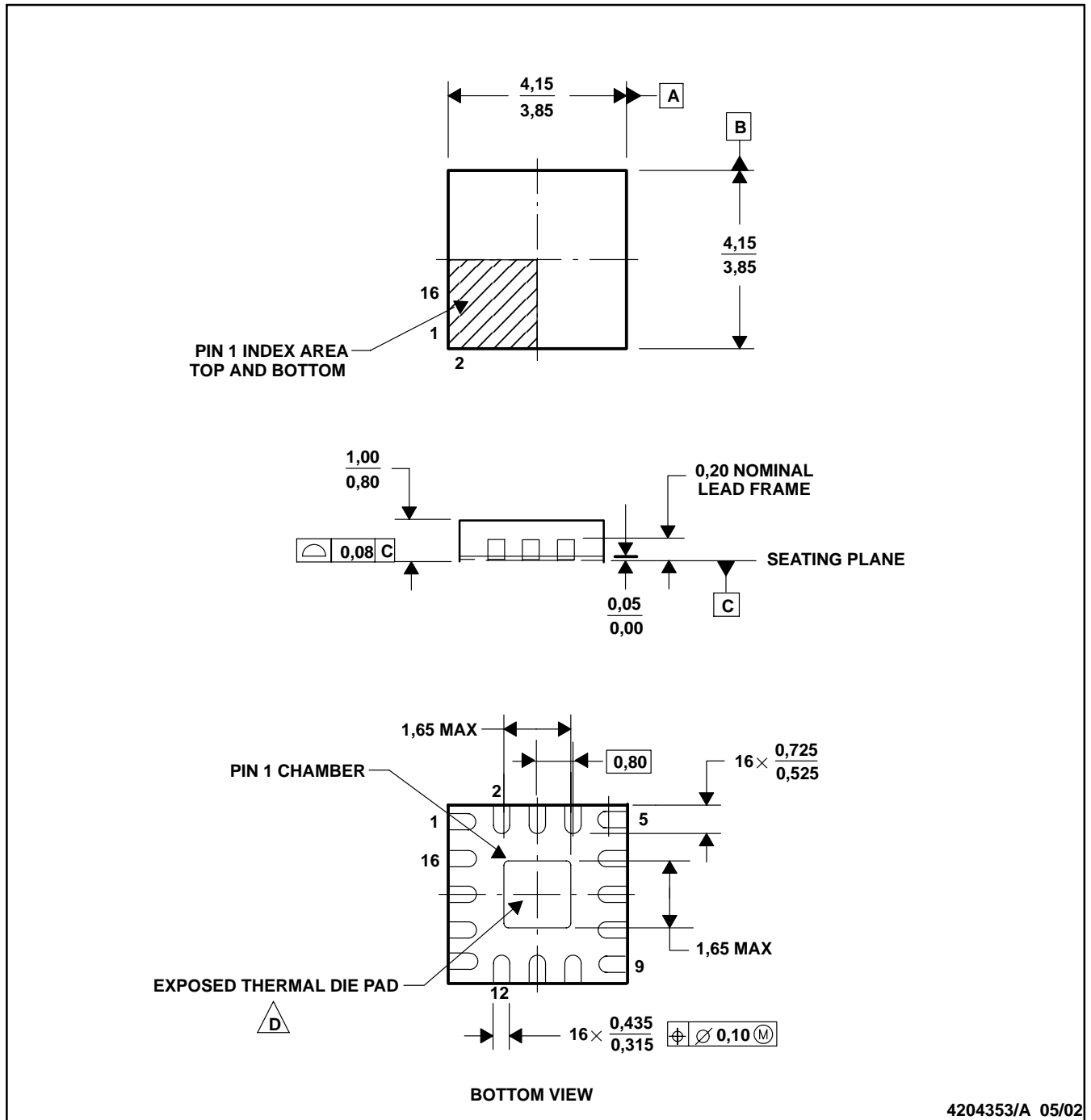

**Figure 55. DAC5686 in Dual-DAC Mode with Quadrature Modulator**

RHC (S-PQFP-N16)

(CUSTOM PACKAGE)

PLASTIC QUAD FLATPACK



- NOTES:
- A. All linear dimensions are in millimeters.
  - B. This drawing is subject to change without notice.
  - C. QFN (Quad Flatpack No-Lead) Package configuration.
  - D. The Package thermal performance may be enhanced by bonding the thermal die pad to an external thermal plane. This pad is electrically and thermally connected to the backside of the die and possibly selected ground leads.

RHC (S-PQFP-N16) (CUSTOM PACKAGE) PLASTIC QUAD FLATPACK

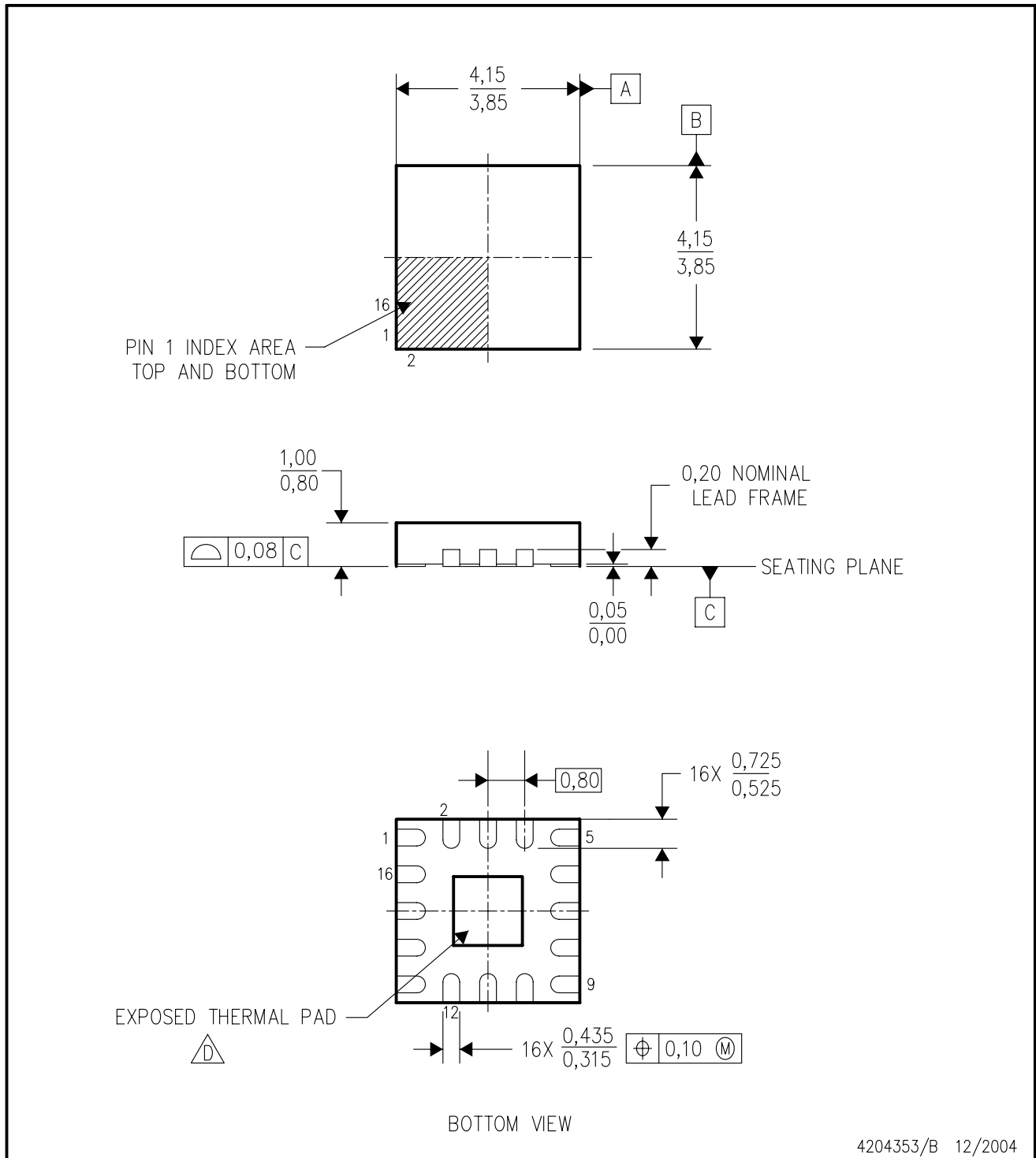

4204353/B 12/2004

- NOTES:
- A. All linear dimensions are in millimeters. Dimensioning and tolerancing per ASME Y14.5M-1994.
  - B. This drawing is subject to change without notice.
  - C. QFN (Quad Flatpack No-Lead) Package configuration.
  -  The package thermal pad must be soldered to the board for thermal and mechanical performance. See the Product Data Sheet for details regarding the exposed thermal pad dimensions.

## IMPORTANT NOTICE

Texas Instruments Incorporated and its subsidiaries (TI) reserve the right to make corrections, modifications, enhancements, improvements, and other changes to its products and services at any time and to discontinue any product or service without notice. Customers should obtain the latest relevant information before placing orders and should verify that such information is current and complete. All products are sold subject to TI's terms and conditions of sale supplied at the time of order acknowledgment.

TI warrants performance of its hardware products to the specifications applicable at the time of sale in accordance with TI's standard warranty. Testing and other quality control techniques are used to the extent TI deems necessary to support this warranty. Except where mandated by government requirements, testing of all parameters of each product is not necessarily performed.

TI assumes no liability for applications assistance or customer product design. Customers are responsible for their products and applications using TI components. To minimize the risks associated with customer products and applications, customers should provide adequate design and operating safeguards.

TI does not warrant or represent that any license, either express or implied, is granted under any TI patent right, copyright, mask work right, or other TI intellectual property right relating to any combination, machine, or process in which TI products or services are used. Information published by TI regarding third-party products or services does not constitute a license from TI to use such products or services or a warranty or endorsement thereof. Use of such information may require a license from a third party under the patents or other intellectual property of the third party, or a license from TI under the patents or other intellectual property of TI.

Reproduction of information in TI data books or data sheets is permissible only if reproduction is without alteration and is accompanied by all associated warranties, conditions, limitations, and notices. Reproduction of this information with alteration is an unfair and deceptive business practice. TI is not responsible or liable for such altered documentation.

Resale of TI products or services with statements different from or beyond the parameters stated by TI for that product or service voids all express and any implied warranties for the associated TI product or service and is an unfair and deceptive business practice. TI is not responsible or liable for any such statements.

Following are URLs where you can obtain information on other Texas Instruments products and application solutions:

<b>Products</b>		<b>Applications</b>	
Amplifiers	<a href="http://amplifier.ti.com">amplifier.ti.com</a>	Audio	<a href="http://www.ti.com/audio">www.ti.com/audio</a>
Data Converters	<a href="http://dataconverter.ti.com">dataconverter.ti.com</a>	Automotive	<a href="http://www.ti.com/automotive">www.ti.com/automotive</a>
DSP	<a href="http://dsp.ti.com">dsp.ti.com</a>	Broadband	<a href="http://www.ti.com/broadband">www.ti.com/broadband</a>
Interface	<a href="http://interface.ti.com">interface.ti.com</a>	Digital Control	<a href="http://www.ti.com/digitalcontrol">www.ti.com/digitalcontrol</a>
Logic	<a href="http://logic.ti.com">logic.ti.com</a>	Military	<a href="http://www.ti.com/military">www.ti.com/military</a>
Power Mgmt	<a href="http://power.ti.com">power.ti.com</a>	Optical Networking	<a href="http://www.ti.com/opticalnetwork">www.ti.com/opticalnetwork</a>
Microcontrollers	<a href="http://microcontroller.ti.com">microcontroller.ti.com</a>	Security	<a href="http://www.ti.com/security">www.ti.com/security</a>
		Telephony	<a href="http://www.ti.com/telephony">www.ti.com/telephony</a>
		Video & Imaging	<a href="http://www.ti.com/video">www.ti.com/video</a>
		Wireless	<a href="http://www.ti.com/wireless">www.ti.com/wireless</a>

Mailing Address: Texas Instruments  
Post Office Box 655303 Dallas, Texas 75265

## Looking for pricing, stock, or lifecycle information?

Click below to explore more details on WIN SOURCE:

 [View TRF3701IRHCR on WIN SOURCE](#)

 [Texas Instruments](#) Information

## Optimize Your Supply Chain with WIN SOURCE Solutions

-  Global Sourcing Solution
-  Obsolete Management
-  Cost Control Management
-  Shortage Management
-  Alternative Solution
-  Excess Inventory Management