



**THE DATASHEET OF
TPSM84A22MOJT**



TPSM84A22, 8-V to 14-V Input, 1.2-V to 2.05-V Output, 10-A SWIFT™ Power Module

1 Features

- Fully Integrated Power Solution Includes Input and Output Capacitors
- Only Requires a Single Voltage Setting Resistor
- 9 mm x 15 mm Footprint
 - 2.3 mm Max Height
 - Pin Compatible with [TPSM84A21](#)
- Ultra-Fast Load Step Response
- Efficiencies up to 90%
- 1% Output Voltage Accuracy
- 4 MHz Switching Frequency
- Synchronizes to an External Clock
- Power Good Output
- Pre-bias Output Start-up
- Programmable Under-Voltage Lockout (UVLO)
- Operating IC Junction Range: -40°C to +125°C
- Operating Ambient Range: -40°C to +85°C
- Meets EN55022 Class B Emissions

2 Applications

- Telecom and Wireless Infrastructure
- Test and Measurement
- Compact PCI/ PCI Express/ PXI Express

3 Description

The TPSM84A22 is an easy-to-use integrated power solution that combines the [TPS54A20](#), a 10-A, DC/DC, synchronous, step-down converter with power MOSFETs, shielded inductors, input and output capacitors, and passives into a low profile package. This total power solution requires only one voltage-setting resistor, and eliminates the loop compensation and magnetics part selection from the design process.

The completely integrated power solution allows standard applications to operate with no additional input or output capacitors and only a single external resistor to set the output voltage. High frequency operation, ultra-fast transient response, and accurate voltage regulation allow the TPSM84A22 to meet tight regulation specs.

The 9 x 15 mm PCB footprint is easy to solder onto a printed circuit board and allows a compact, low-profile point-of-load design.

Device Information⁽¹⁾

PART NUMBER	PACKAGE	BODY SIZE (NOM)
TPSM84A22	QFM	9.00 mm x 15.00 mm

(1) For all available packages, see the orderable addendum at the end of the data sheet.

Device Comparison

PART NUMBER	V _{OUT} ADJUST RANGE
TPSM84A21	0.55 V - 1.35 V
TPSM84A22	1.2 V - 2.05 V

Simplified Schematic

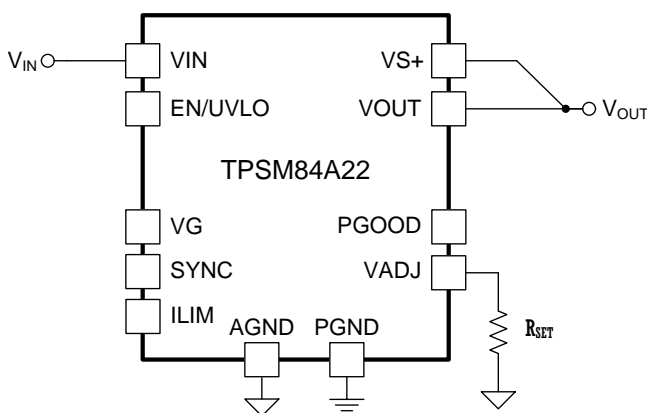

Copyright © 2016, Texas Instruments Incorporated

Transient Response

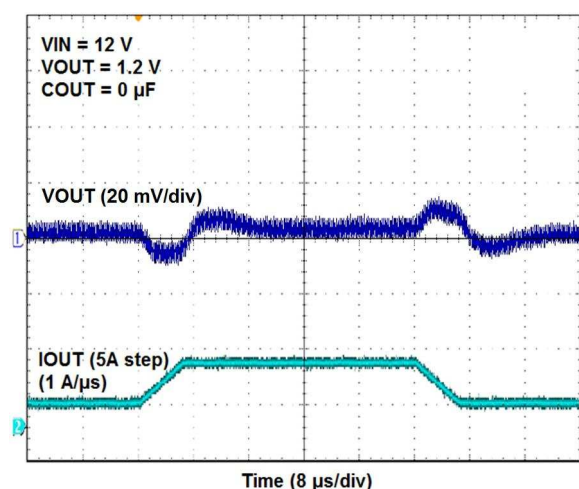

Table of Contents

1 Features	1	7.4 Device Functional Modes.....	16
2 Applications	1	8 Application and Implementation	17
3 Description	1	8.1 Application Information.....	17
4 Revision History	2	8.2 Typical Application	17
5 Pin Configuration and Functions	3	9 Power Supply Recommendations	19
6 Specifications	4	10 Layout	20
6.1 Absolute Maximum Ratings	4	10.1 Layout Guidelines	20
6.2 ESD Ratings.....	4	10.2 Layout Examples.....	20
6.3 Recommended Operating Conditions.....	4	10.3 EMI.....	22
6.4 Thermal Information	5	11 Device and Documentation Support	23
6.5 Electrical Characteristics.....	5	11.1 Documentation Support	23
6.6 Switching Characteristics	7	11.2 Receiving Notification of Documentation Updates	23
6.7 Package Specifications	7	11.3 Community Resources.....	23
6.8 Typical Characteristics	8	11.4 Trademarks	23
7 Detailed Description	11	11.5 Electrostatic Discharge Caution.....	23
7.1 Overview	11	11.6 Glossary	23
7.2 Functional Block Diagram	11	12 Mechanical, Packaging, and Orderable	23
7.3 Feature Description.....	12	Information	23
		12.1 Tape and Reel Information	24

4 Revision History

Changes from Revision A (April 2017) to Revision B	Page
• Deleted <i>Feature</i> MSL 3 / 260°C Peak Reflow (Refer to Package Option Addendum)	1
• Added the <i>EMI</i> section	22

Changes from Original (December 2016) to Revision A	Page
• Changed max reflow temp from 245C to 260C	1

5 Pin Configuration and Functions

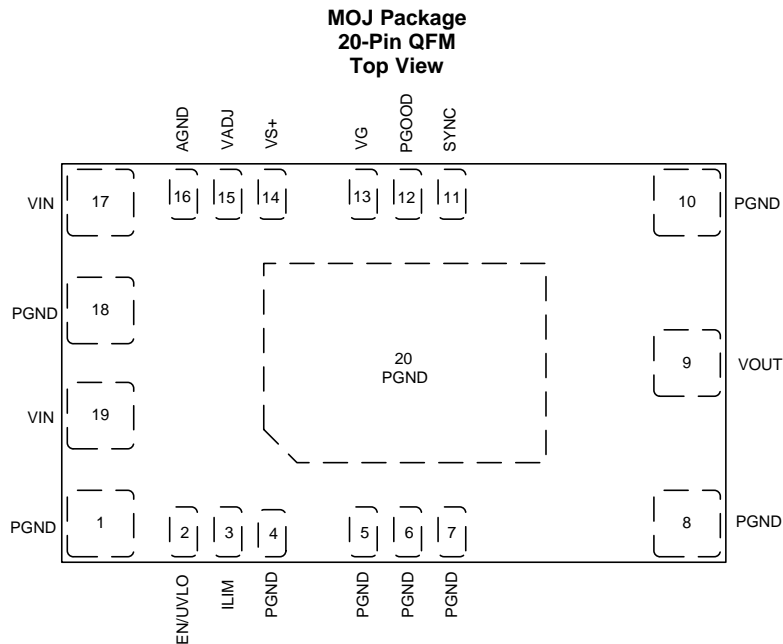

Pin Functions

PIN		I/O	DESCRIPTION
NAME	NO.		
AGND	16	—	Zero voltage reference for analog control circuitry. Connect RSET between this pin and VADJ close to the device. Do not connect this pin to PGND; the connection is made internal to the device.
EN/UVLO	2	I	Enable and UVLO adjust pin. When this pin voltage is low, the device is disabled. Use an open drain, open collector, or a suitable logic gate device to control the enable function. A resistor divider between this pin, PGND, and VIN adjusts the UVLO voltage.
ILIM	3	I	Current limit setting pin. Leave this open for the full current limit threshold of 15 A. Connect a 47 kΩ resistor between this pin and PGND to reduce the current limit threshold to 11.25 A.
PGND	1, 4, 5, 6, 7, 8, 10, 18, 20	—	Power ground of the device. Connect these pins to the power ground plane of the PCB. Thermal vias to internal ground planes should be added beneath pin 20.
PGOOD	12	O	Power good indicator. This pin is an open-drain output and will assert low if the output voltage is greater than ±5% from the programmed value or due to thermal shutdown, under-voltage, or EN shutdown. A pull-up resistor is required. VG can be used as a PGOOD pull-up source.
VS+	14	I	Remote sense connection. This pin must be connected to VOUT at the load or at the device pins. Connect the pin to VOUT at the load for improved regulation.
SYNC	11	I	External clock synchronization pin. An external clock signal can be applied to this pin to synchronize the switching frequency within ±10% of the nominal switching frequency (4 MHz).
VADJ	15	I	Output voltage adjust pin. Connecting a resistor between this pin and AGND sets the output voltage.
VG	13	I	Gate driver supply pin. If this pin is left open, an internal LDO will generate the gate driver supply voltage from the VIN pin. To reduce power consumption and improve efficiency, power this pin with an external 5-V supply. This pin can be used as a PGOOD pull-up source.
VIN	17, 19	I	Input Voltage. These pins supply all of the power to the converter. Connect VIN to a supply voltage between 8 V and 14 V.
VOUT	9	O	Output voltage. Connect any external output capacitors between these pins and PGND.

6 Specifications

6.1 Absolute Maximum Ratings

over operating free-air temperature range (unless otherwise noted)⁽¹⁾

		MIN	MAX	UNIT
Input voltage	V _{IN}	-0.3	15	V
	EN/UVLO	-0.3	7	V
	PGOOD, SYNC, VG	-0.3	6	V
	ILIM, VADJ, VS+	-0.3	3	V
	PGND	-0.3	0.3	V
Output voltage	V _{OUT}	-0.3	3	V
Source current	EN/UVLO		100	μA
Sink current	VG		100	mA
	PGOOD		4	mA
Mechanical shock	Mil-STD-883D, Method 2002.3, 1 msec, 1/2 sine, mounted		500	G
Mechanical vibration	Mil-STD-883D, Method 2007.2, 20-2000Hz		20	G
Operating IC junction temperature, T _J ⁽²⁾		-40	125	°C
Operating ambient temperature, T _A ⁽²⁾		-40	85	°C
Storage temperature, T _{stg}		-55	150	°C

- (1) Stresses beyond those listed under *Absolute Maximum Ratings* may cause permanent damage to the device. These are stress ratings only, which do not imply functional operation of the device at these or any other conditions beyond those indicated under *Recommended Operating Conditions*. Exposure to absolute-maximum-rated conditions for extended periods may affect device reliability.
- (2) The ambient temperature is the air temperature of the surrounding environment. The junction temperature is the temperature of the internal power IC when the device is powered. Operating below the maximum ambient temperature, as shown in the safe operating area (SOA) curves, ensures that the maximum junction temperature of any component inside the module is never exceeded.

6.2 ESD Ratings

		VALUE	UNIT
V _(ESD) Electrostatic discharge	Human-body model (HBM), per ANSI/ESDA/JEDEC JS-001 ⁽¹⁾	±2500	V
	Charged-device model (CDM), per JEDEC specification JESD22-C101 ⁽²⁾	±1500	

- (1) JEDEC document JEP155 states that 500-V HBM allows safe manufacturing with a standard ESD control process.
- (2) JEDEC document JEP157 states that 250-V CDM allows safe manufacturing with a standard ESD control process.

6.3 Recommended Operating Conditions

over operating free-air temperature range (unless otherwise noted)

		MIN	NOM	MAX	UNIT
V _{IN}	Input voltage	8		14	V
V _{OUT}	Output voltage	1.2		2.05	V
V _{VG}	Gate drive voltage	5.0		5.5	V
V _{EN}	EN voltage	0		5.5	V
V _{PGOOD}	PGOOD pull-up voltage	0		5.5	V
V _{SYNC}	SYNC voltage	0		5.5	V
I _{OUT}	Output current	0		10	A
T _J	Operating IC junction temperature ⁽¹⁾	-40		125	°C
T _A	Operating ambient temperature ⁽¹⁾	-40		85	°C

- (1) The ambient temperature is the air temperature of the surrounding environment. The junction temperature is the temperature of the internal power IC when the device is powered. Operating below the maximum ambient temperature, as shown in the safe operating area (SOA) curves, ensures that the maximum junction temperature of any component inside the module is never exceeded.

6.4 Thermal Information

THERMAL METRIC ⁽¹⁾		TPSM84A22	UNIT
		MOJ (QFM)	
		20 PINS	
R _{θJA}	Junction-to-ambient thermal resistance ⁽²⁾	14.9	°C/W
ψ _{JT}	Junction-to-top characterization parameter ⁽³⁾	2.2	°C/W
ψ _{JB}	Junction-to-board characterization parameter ⁽⁴⁾	5.7	°C/W

- (1) For more information about traditional and new thermal metrics, see the [Semiconductor and IC Package Thermal Metrics](#) application report.
- (2) The junction-to-ambient thermal resistance, Θ_{JA} , applies to devices soldered directly to a 50 mm x 100 mm double-sided PCB with 2 oz. copper and natural convection cooling. Additional airflow reduces Θ_{JA} .
- (3) The junction-to-top board characterization parameter, ψ_{JT} , estimates the junction temperature, T_J , of a device in a real system, using a procedure described in JESD51-2A (section 6 and 7). $T_J = \psi_{JT} * P_{dis} + T_T$; where P_{dis} is the power dissipated in the device and T_T is the temperature of the top of the device.
- (4) The junction-to-board characterization parameter, ψ_{JB} , estimates the junction temperature, T_J , of a device in a real system, using a procedure described in JESD51-2A (sections 6 and 7). $T_J = \psi_{JB} * P_{dis} + T_B$; where P_{dis} is the power dissipated in the device and T_B is the temperature of the board 1mm from the device.

6.5 Electrical Characteristics

Over -40°C to $+85^{\circ}\text{C}$ free-air temperature range, $V_{IN} = 12\text{ V}$, $V_{OUT} = 1.5\text{ V}$, $I_{OUT} = I_{OUT\text{ max}}$, $F_{SW} = 4\text{ MHz}$,
External $C_{IN} = 2 \times 22\text{ }\mu\text{F}$ 25 V 1210 ceramic plus $1 \times 100\text{ }\mu\text{F}$ electrolytic (unless otherwise noted)

PARAMETER		TEST CONDITIONS	MIN	TYP	MAX	UNIT
INPUT VOLTAGE (VIN)						
V _{IN}	VIN input voltage range	Over V _{OUT} range	8 ⁽¹⁾		14	V
V _{IN_UVLO}	VIN under voltage lock out	V _{IN} increasing		7.65	7.95	V
		V _{IN} decreasing		7.4		V
V _{IN_HYS}	VIN UVLO hysteresis			250		mV
I _{VIN_EN}	VIN standby current	EN = 0 V		47		μA
OUTPUT VOLTAGE (VOUT)						
V _{OUT(ADJ)}	Output voltage adjust range	Over I _{OUT} range	1.2		2.05	V
V _{OUT}	Set-point voltage tolerance	V _{OUT} = 1.5 V, T _A = 25°C, I _{OUT} = 0 A	-1.0%		+1.0% ⁽²⁾	
	Temperature variation	V _{OUT} = 1.5 V, $-40^{\circ}\text{C} \leq T_A \leq 85^{\circ}\text{C}$, I _{OUT} = 0 A		±0.2% ⁽³⁾		
	Line regulation	V _{OUT} = 1.5 V, over V _{IN} range, I _{OUT} = 0 A, T _A = 25°C		±0.03%		
	Load regulation	V _{OUT} = 1.5 V, over I _{OUT} range, T _A = 25°C		±0.1%		
V _{OUT} Ripple	Output voltage ripple	20 MHz bandwidth, peak-to-peak		9		mV
OUTPUT CURRENT						
I _{OUT}	Output current	See SOA graph for derating over temperature.	0		10	A
	Overcurrent threshold	ILIM = open		15		A
		ILIM = 47 kΩ			11.25	

- (1) The minimum VIN is 8V or (VOUT x 5.3), whichever is greater.
- (2) The stated limit of the set-point tolerance includes the tolerance of both the internal voltage reference and the internal adjustment resistor. The overall output voltage tolerance will be affected by the tolerance of the external R_{SET} resistor.
- (3) Specified by design. Not production tested.

Electrical Characteristics (continued)

Over -40°C to $+85^{\circ}\text{C}$ free-air temperature range, $V_{\text{IN}} = 12\text{ V}$, $V_{\text{OUT}} = 1.5\text{ V}$, $I_{\text{OUT}} = I_{\text{OUT max}}$, $F_{\text{SW}} = 4\text{ MHz}$,
External $C_{\text{IN}} = 2 \times 22\text{ }\mu\text{F}$ 25 V 1210 ceramic plus $1 \times 100\text{ }\mu\text{F}$ electrolytic (unless otherwise noted)

PARAMETER		TEST CONDITIONS	MIN	TYP	MAX	UNIT
PERFORMANCE						
η	Efficiency ⁽³⁾	$V_{\text{IN}} = 12\text{ V}$, $I_{\text{OUT}} = 5\text{ A}$	$V_{\text{OUT}} = 1.2\text{ V}$, $\text{VG} = \text{open}$	84.2%		
			$V_{\text{OUT}} = 1.2\text{ V}$, $\text{VG} = 5\text{ V}$	86.2%		
			$V_{\text{OUT}} = 1.5\text{ V}$, $\text{VG} = \text{open}$	85.7%		
			$V_{\text{OUT}} = 1.5\text{ V}$, $\text{VG} = 5\text{ V}$	87.5%		
			$V_{\text{OUT}} = 1.8\text{ V}$, $\text{VG} = \text{open}$	87.4%		
			$V_{\text{OUT}} = 1.8\text{ V}$, $\text{VG} = 5\text{ V}$	89.0%		
Transient response ⁽³⁾	1 A/ μs load step, 25% to 75% $I_{\text{OUT}}(\text{max})$, $C_{\text{OUT}} = 0\text{ }\mu\text{F}$	VOUT over/undershoot		15		mV
		Recovery time		10		μs
	5 A/ μs load step, 25% to 75% $I_{\text{OUT}}(\text{max})$, $C_{\text{OUT}} = 0\text{ }\mu\text{F}$	VOUT over/undershoot		30		mV
		Recovery time		10		μs
SOFT START						
T_{SS}	Internal soft start time ⁽³⁾			4.1		ms
INTERNAL REGULATOR (VG)						
V_{VG}	VG pin output voltage		4.4	4.8	5.0	V
ENABLE AND UNDER-VOLTAGE LOCK-OUT (EN/UVLO)						
V_{EN}	EN threshold range		1.17	1.23	1.27	V
I_{EN}	Input current	EN threshold + 50 mV		-4		μA
	Hysteresis current	EN threshold - 50 mV		-1		μA
POWER GOOD (PGOOD)						
V_{PGOOD}	PGOOD thresholds ⁽³⁾	V_{VOUT} falling (Fault)		89%		
		V_{VOUT} rising (Good)		95%		
		V_{VOUT} rising (Fault)		109%		
		V_{VOUT} falling (Good)		104%		
	Minimum V_{IN} for valid PGOOD ⁽³⁾	$V_{\text{PGOOD}} \leq 0.5\text{ V}$ at $100\text{ }\mu\text{A}$		1.2	2.75	V
	PGOOD low voltage	$I_{\text{PGOOD}} = 1.7\text{ mA}$		0.25	0.3	V
THERMAL SHUTDOWN						
	Thermal shutdown threshold			135		$^{\circ}\text{C}$
	Thermal shutdown hysteresis			20		$^{\circ}\text{C}$
CAPACITANCE						
C_{IN}	External input capacitance	Ceramic type	0 ⁽⁴⁾	44		μF
		Non-ceramic type	0 ⁽⁴⁾	100		μF
C_{OUT}	External output capacitance	Ceramic type	0 ⁽⁵⁾		1000 ⁽⁶⁾	μF
		Non-ceramic type	0 ⁽⁵⁾		2200 ⁽⁶⁾	μF
		Equivalent series resistance (ESR)				35

- (4) Internal to the device, 14.2 μF (nominal) ceramic input capacitance is present. This device does not require additional input capacitance. If adding additional input capacitance, locate the capacitors close to the device.
- (5) Internal to the device, 135 μF (nominal) ceramic output capacitance is present. This device does not require additional output capacitance to operate. Adding additional output capacitance near the load improves the response of the device to load transients.
- (6) The maximum output capacitance listed in the table is the maximum amount that has been tested and validated for proper start-up, stability, and transient response. It may be possible to operate with additional output capacitance, however, additional validation is required.

6.6 Switching Characteristics

over operating free-air temperature range (unless otherwise noted)

PARAMETER		TEST CONDITIONS	MIN	TYP	MAX	UNIT
FREQUENCY AND SYNCHRONIZATION (SYNC) ⁽¹⁾						
F _{SW}	Switching frequency	SYNC = open	3.7	4	4.3	MHz
F _{SYNC}	Synchronization frequency range	SYNC control	3.6		4.4	MHz
V _{SYNC-H}	SYNC high threshold		2.0			V
V _{SYNC-L}	SYNC low threshold				0.8	V
D _{SYNC}	SYNC duty cycle		20%		80%	

(1) Specified by design. Not production tested.

6.7 Package Specifications

TPSM84A22		VALUE	UNIT
Weight		0.91	grams
Flammability	Meets UL 94 V-O		
MTBF Calculated Reliability	Per Bellcore TR-332, 50% stress, T _A = 40°C, ground benign	30.6	MHrs

6.8 Typical Characteristics

The electrical characteristic data has been developed from actual products tested at 25°C. This data is considered typical for the converter. Applies to [Figure 1](#), [Figure 2](#), [Figure 3](#), [Figure 4](#) and [Figure 11](#).

The temperature derating curves represent the conditions at which internal components are at or below the manufacturer's maximum operating temperatures. Derating limits apply to devices soldered directly to a 50 mm x 100 mm double-sided PCB with 2 oz. copper. Applies to [Figure 5](#) and [Figure 6](#).

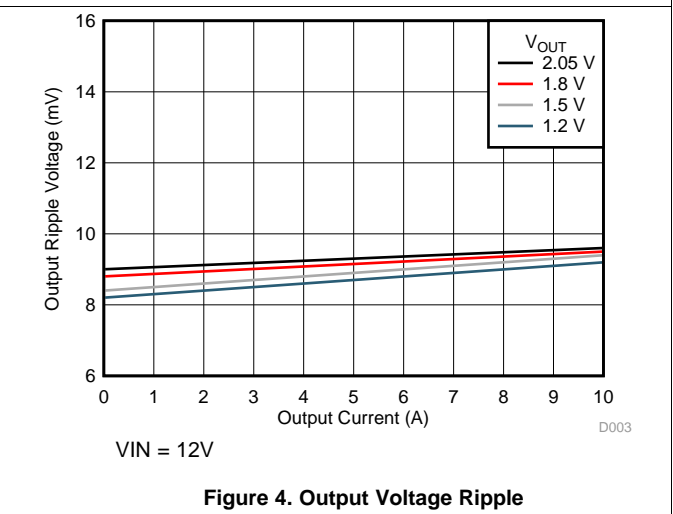
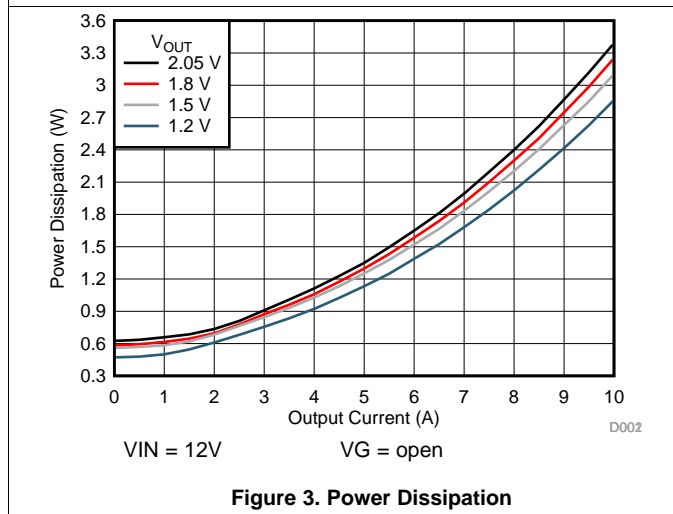
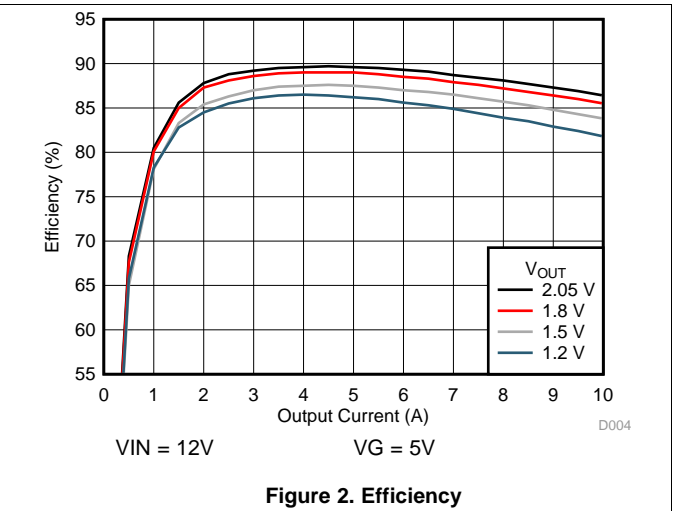
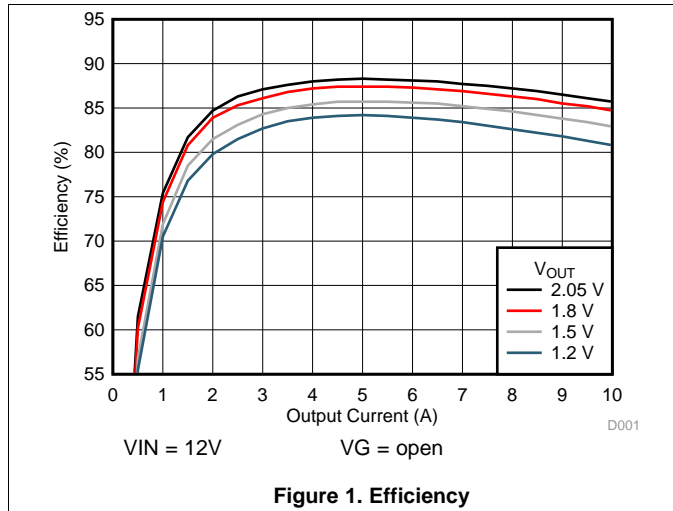

Typical Characteristics (continued)

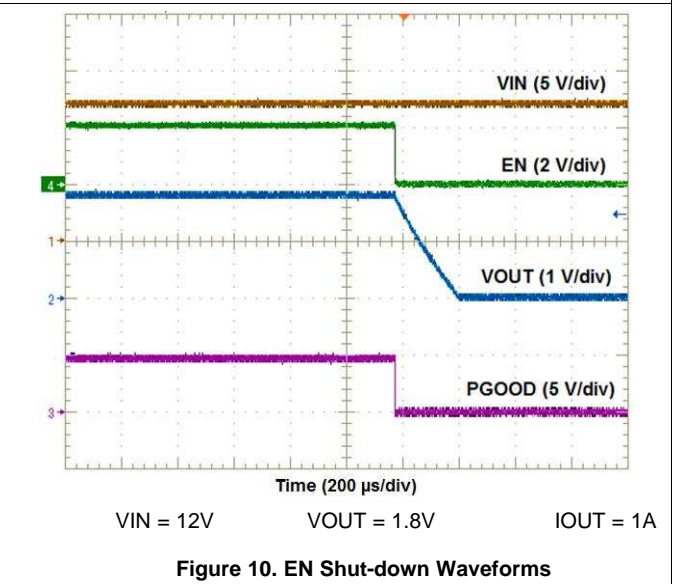
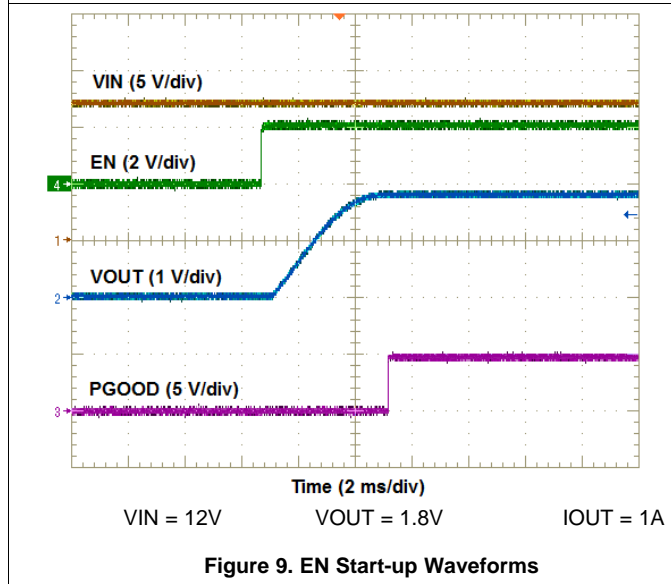
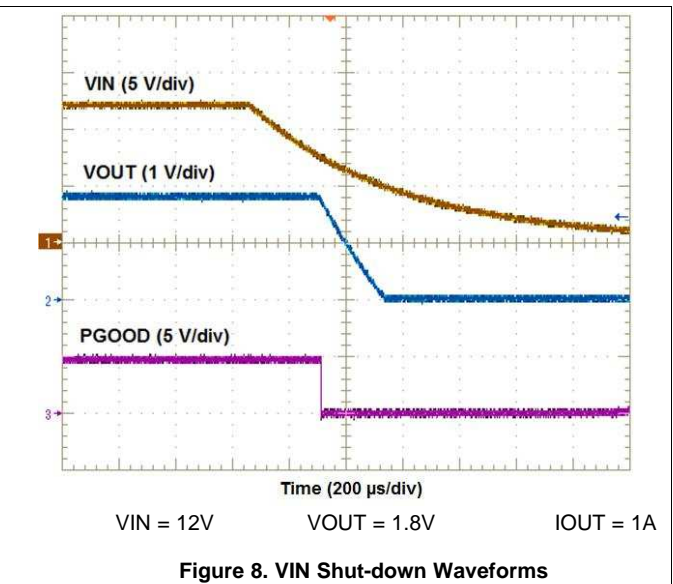
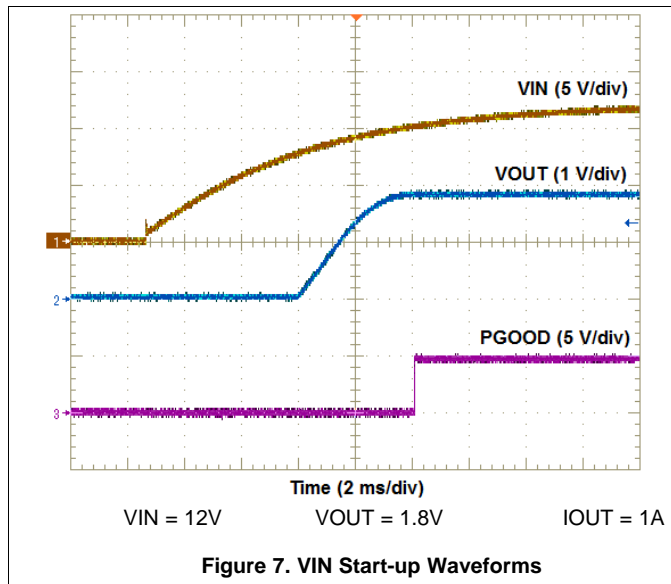
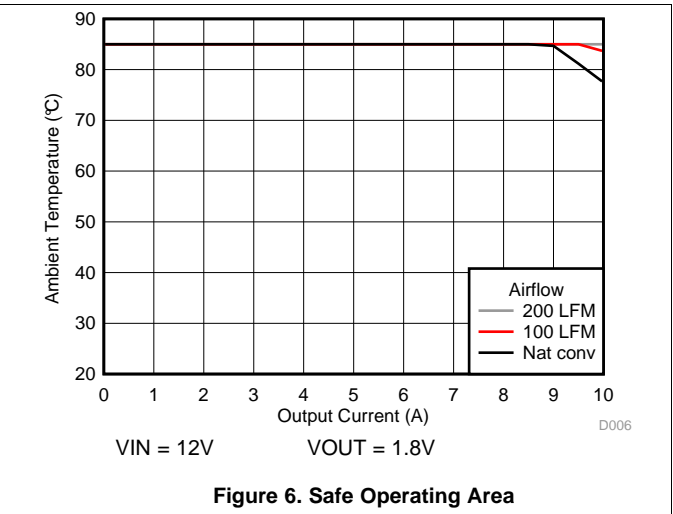
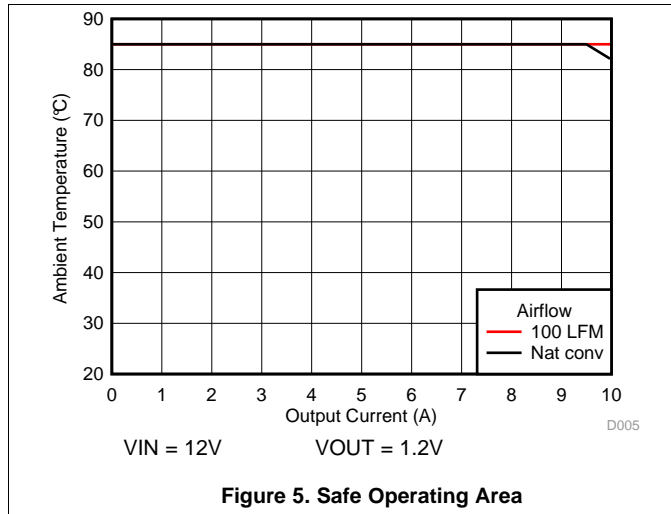

Typical Characteristics (continued)

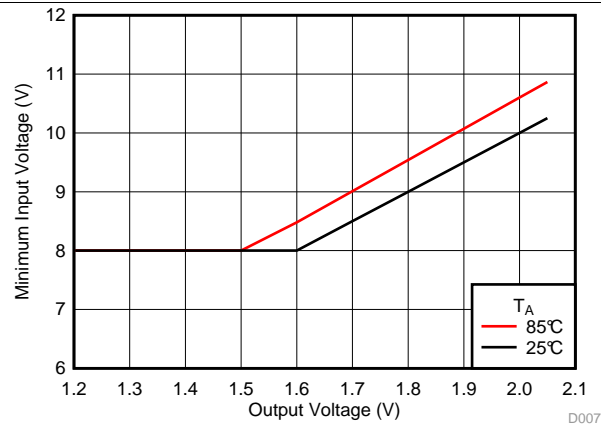

Figure 11. Minimum Input Voltage

D007

7 Detailed Description

7.1 Overview

The TPSM84A22 is a 14-V, 10-A, synchronous series capacitor step-down (buck) power module. The TPSM84A22 combines a 10-A DC/DC converter with power MOSFETs, shielded inductors, series capacitor, input and output capacitors, and passives into a low profile, overmolded package. The integrated input and output capacitors allows standard applications to operate with no additional input or output capacitors and only a single resistor to set the output voltage.

The integrated components allow for high-efficiency, high-density, complete power supply designs with continuous output currents up to 10 A. The TPSM84A22 reduces the external component count by integrating both the input and output capacitors. The TPSM84A22 input voltage range is 8 V to 14 V with an output voltage range of 1.2 V to 2.05 V.

The TPSM84A22 is a two-phase power supply with each phase switching at a fixed 2 MHz frequency, resulting in the internal oscillator frequency of 4 MHz. An external synchronization clock can also be provided via the SYNC pin.

The TPSM84A22 starts up safely into loads with pre-biased outputs (non-zero volts at startup). The device implements an internal input voltage under voltage lockout (UVLO) feature which can be adjusted higher by adding an external resistor divider on the EN/UVLO pin. Electrical ON/OFF control is provided using the enable (EN) feature. The TPSM84A22 is disabled by pulling the EN pin low. When the device is disabled, the supply current is typically less than 50 μ A.

The TPSM84A22 has a power good comparator (PGOOD) which monitors the output voltage through the VS+ pin. The PGOOD pin is an open-drain MOSFET which is held low until the output voltage is within $\pm 5\%$ of the set voltage. The PGOOD pin is held low during startup or when a fault occurs.

7.2 Functional Block Diagram

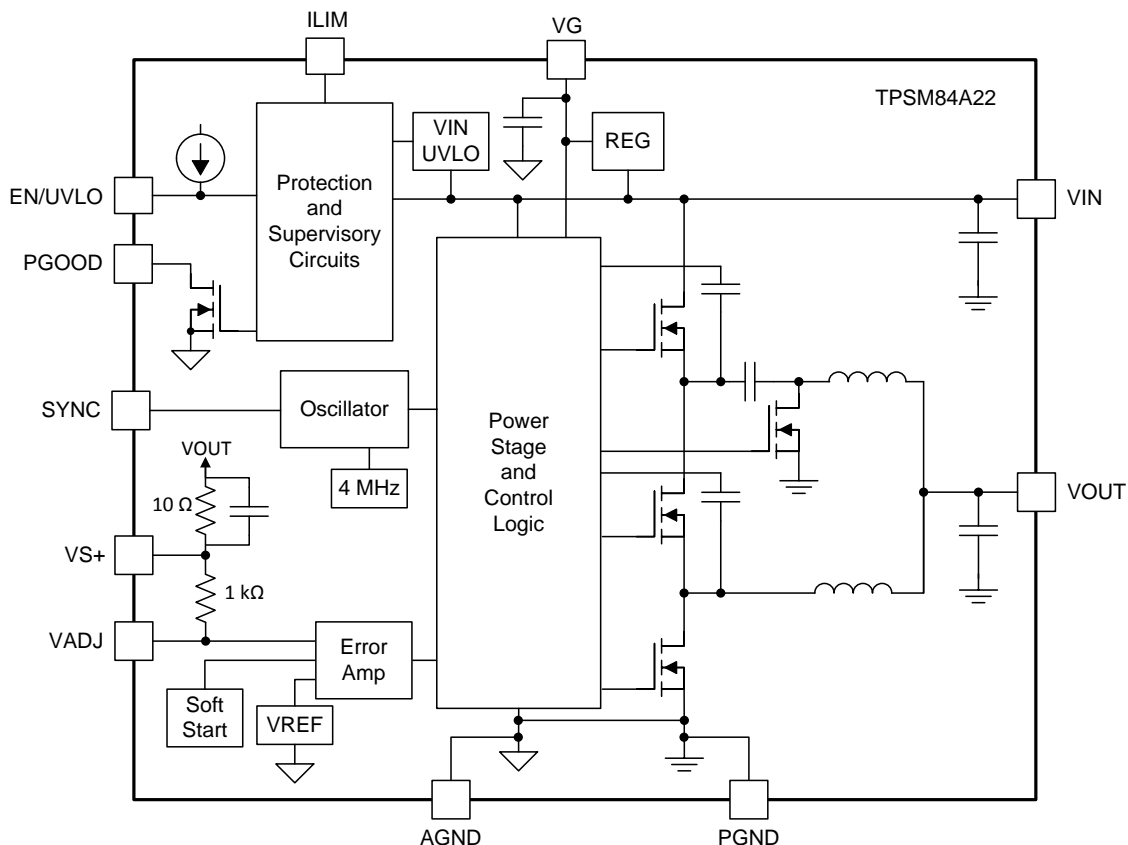

Copyright © 2016, Texas Instruments Incorporated

7.3 Feature Description

7.3.1 Adjusting the Output Voltage (VADJ)

The VADJ pin programs the output voltage of the TPSM84A22. The output voltage adjustment range is from 1.2 V to 2.05 V. The adjustment method requires the addition of R_{SET} connected between VADJ and AGND. If an R_{SET} resistor is not populated, the module will default to 0.508 V, which is outside of the operation range of this device. The VS+ pin (pin 14) must be connected to VOUT. TI recommends to make the VS+ connection at the load for the best load regulation performance. The R_{SET} resistor must be connected directly between the VADJ pin (pin 15) and AGND (pin 16).

Equation 1 can be used to calculate the ideal R_{SET} resistor value for a given output voltage, V_{OUT}. Use Equation 2 to calculate the actual V_{OUT} for a given R_{SET} resistor. Table 1 lists the ideal R_{SET} resistor values for a number of common voltages. Table 1 also lists the closest E96 standard resistor values to the ideal R_{SET} values along with the actual output voltage and the set-point error when using the E96 resistor value. For the most accurate output voltage set-point it is best to use the ideal resistor value. The ideal resistor value may not be a standard value and may require two standard value resistors in series or parallel to obtain the desired output voltage.

$$R_{SET} = \frac{1}{\frac{V_{OUT}}{0.508} - 1} \text{ (k}\Omega\text{)} \quad (1)$$

$$V_{OUT} = 0.508 * \left(\frac{1}{R_{SET} \text{ (k}\Omega\text{)}} + 1 \right) \text{ (V)} \quad (2)$$

Table 1. R_{SET} Resistor Values

V _{OUT} (V)	Ideal R _{SET} (kΩ)	Closest E96 Resistor Value		
		R _{SET} (kΩ)	Actual V _{OUT} (V)	%
1.20	0.734	0.732	1.202	0.166
1.25	0.685	0.681	1.254	0.317
1.30	0.641	0.649	1.291	-0.712
1.35	0.603	0.604	1.349	-0.070
1.40	0.570	0.576	1.390	-0.718
1.45	0.539	0.536	1.456	0.397
1.50	0.512	0.511	1.502	0.142
1.55	0.488	0.487	1.551	0.072
1.60	0.465	0.464	1.603	0.177
1.65	0.445	0.442	1.657	0.444
1.70	0.426	0.422	1.712	0.694
1.75	0.409	0.412	1.741	-0.514
1.80	0.393	0.392	1.804	0.218
1.85	0.379	0.383	1.834	-0.845
1.90	0.365	0.365	1.899	-0.012
1.95	0.352	0.348	1.968	0.911
2.00	0.341	0.340	2.002	0.106
2.05	0.329	0.332	2.038	-0.579

7.3.2 Input and Output Capacitance

The TPSM84A22 requires no external input or output capacitance to operate. Internal to the TPSM84A22 there is 14.2 μF (nominal) of ceramic input capacitance. Additionally, internal to the TPSM84A22 there is 135 μF (nominal) of ceramic output capacitance.

Applications requiring additional ripple voltage reduction should add ceramic input and output capacitors directly at the VIN and VOUT pins of the device. Applications requiring improved transient response can also benefit by adding additional ceramic or low-ESR bulk output capacitance. See the Capacitance section of the [Electrical Characteristics](#) table for more information when adding external input and output capacitors.

7.3.3 Transient Response

The exceptional transient response of the TPSM84A22 allows many applications to operate with little or no additional output capacitance. [Figure 12](#) through [Figure 15](#) show typical transient waveforms for the TPSM84A22 with no output capacitance added.

7.3.3.1 Transient Response Waveforms

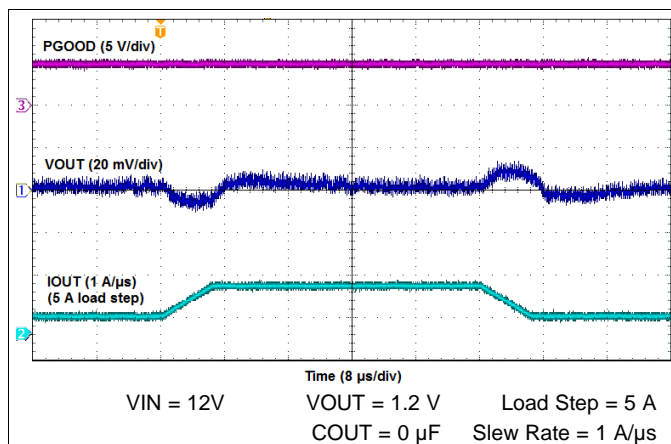

Figure 12. Transient Response

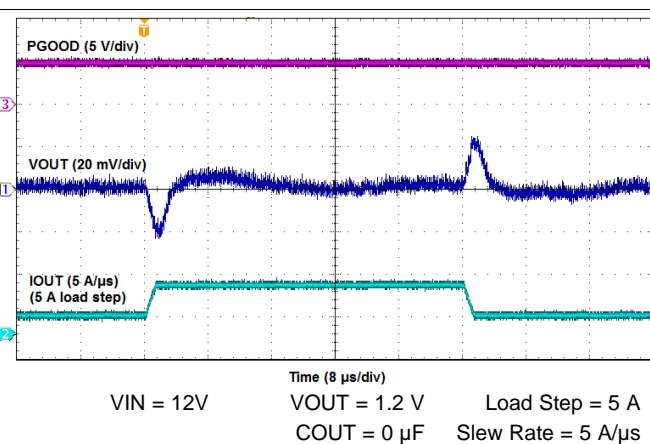

Figure 13. Transient Response

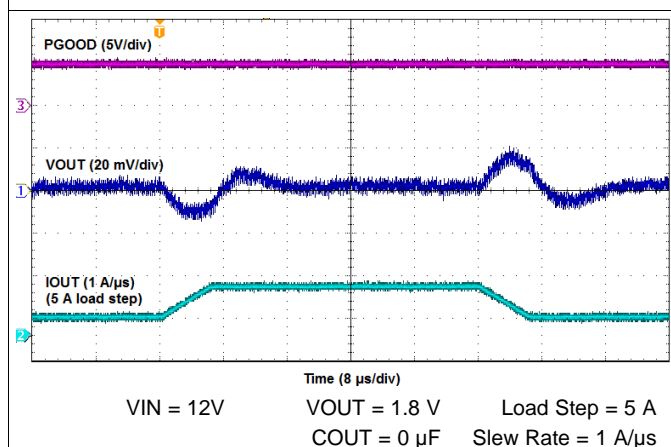

Figure 14. Transient Response

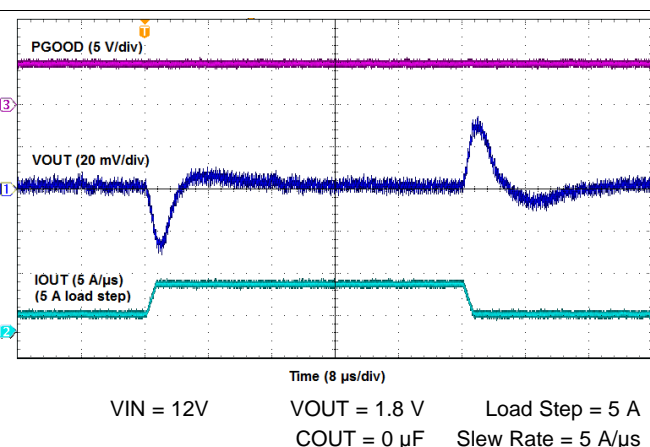

Figure 15. Transient Response

7.3.4 Oscillator Frequency

The oscillator frequency of this converter is set at 4 MHz. The per phase switching frequency of the converter is half the oscillator frequency, or 2 MHz per phase. The oscillator frequency is fixed internally.

During load transients, the internal control loop will momentarily change the switching frequency in order to meet the output voltage recovery.

7.3.5 External Clock Synchronization

An external clock can be connected to the SYNC pin. The external clock signal overrides the internal oscillator and is used as the system clock. This feature enables the user to synchronize the switching events to a master clock on their board. The internal phase locked loop (PLL) has been implemented to allow synchronization at frequencies between $\pm 10\%$ of the nominal oscillator frequency. This allows the user to easily switch between the internal oscillator mode and the external clock mode while converting power. Before the external clock is present or after it is removed, the device with default to the internal oscillator setting.

To implement the synchronization feature, connect a square wave clock signal to the SYNC pin with a duty cycle between 20% and 80%. The clock signal amplitude must transition lower than 0.8 V and higher than 2 V. The start of the switching cycle is synchronized to the rising edge of the SYNC pin. The device can be configured for operation in applications where both an internal oscillator mode and an external synchronization clock mode are needed. Before the external clock is present, the switching frequency of the device is set by the internal oscillator. When the external clock is present, the SYNC mode overrides the internal oscillator. The first time the SYNC pin is pulled above the SYNC high threshold (2 V), the device switches from the internal oscillator mode to the SYNC mode and the PLL starts to lock onto the frequency of the external clock. When the external SYNC clock is removed, the converter will transition back to the internal oscillator after 4 internal clock cycles.

7.3.6 Soft Start

The TPSM84A22 has a pre-programmed soft start time of 4.1 ms (typ). The soft start time is the time it takes for the output voltage to rise from zero volts to the voltage set by the R_{SET} resistor. Soft start is an important feature that limits inrush current and reduces the load on the input supply to this device. During soft start, the internal reference voltage is slowly ramped up to the internal reference voltage. This slowly increases the commanded output voltage of the converter and reduces the initial surge in current. During soft start PGOOD remains low, the PLL is not active, and output UVP/OVP faults are disabled.

7.3.7 Power Good (PGOOD)

The Power Good (PGOOD) pin is an open drain output. After startup, when the VADJ pin is typically between 95% and 105% of the internal voltage reference, the PGOOD pin pull-down is released and the pin floats. The recommended pull-up resistor value is between 10 k Ω and 100 k Ω to a voltage source of 5.5 V or less. For convenience, VG can be used as the pull-up voltage. The PGOOD is in a defined state once the VIN input voltage is greater than approximately 1.2 V, but with reduced current sinking capability. The PGOOD achieves full current sinking capability once the VIN input voltage is above the input UVLO. The PGOOD pin is pulled low when the VADJ pin voltage is typically lower than 95% or greater than 105% of the nominal internal reference voltage. The PGOOD pin is also pulled low if a fault is detected, the EN pin is pulled low, or the converter is performing its soft-start power up sequence.

7.3.8 Gate Driver (VG)

A linear regulator internal to the TPSM84A22 generates a 4.8 V internal supply rail on the VG pin. The input of the linear regulator comes from the VIN pin. The VG supply rail is used to power the internal gate drivers and is the input to another regulator that generates the internal supply rails used by the controller. To improve converter efficiency, an external 5 V supply is recommended to be connected to the VG pin, thereby overriding the internal 4.8 V regulator. This external supply must be between 5.0 V and 5.5 V and must be present before applying input voltage to the VIN pin. If not supplying an external voltage to this pin, leave this pin open.

7.3.9 Startup into Pre-biased Outputs

The TPSM84A22 prevents the low-side MOSFETs from discharging a pre-biased output. During pre-biased startup, the low-side MOSFETs do not turn on until after the high-side MOSFETs have started switching. The high-side MOSFETs do not start switching until the internal soft-start reference voltage exceeds the voltage at the VADJ pin.

7.3.10 Thermal Shutdown

The internal thermal shutdown fault is triggered if the junction temperature exceeds 135°C (typ). This interrupts regulation by making the output high impedance. The device reinitiates the power up sequence when the junction temperature drops below 115°C (typ).

7.3.11 Overcurrent Protection

For protection against load faults, the TPSM84A22 incorporates output overcurrent protection. Applying a load that exceeds the module's overcurrent threshold causes the output to shut down and PGOOD is pulled low. Following shut down, the module attempts to restart after a 32.8-ms hiccup interval counter has expired. This provides a hiccup response to an overcurrent condition. During this period, the average current flowing into the fault is significantly reduced which reduces power dissipation. Once the fault is removed, the module automatically recovers and returns to normal operation.

The TPSM84A22 overcurrent trip point is 15 A (typ) when the ILIM pin is left open. This provides enough margin for brief overshoots in inductor currents during a load transient while at the same time protecting against short circuits or other potentially catastrophic faults on the output. The overcurrent trip point can be reduced to 11.25 A (typ) by placing a 47 kΩ between the ILIM pin and PGND. Programming resistors with up to ±5% variation can be used. The current limit selection is latched in at power up and cannot be changed without cycling input power or the EN pin voltage.

7.3.12 Output Undervoltage/Overvoltage Protection

The device incorporates an output undervoltage/overvoltage protection (UVP/OVP) circuit to prevent damage to the load. This fault can be triggered during large, fast load transients if insufficient output capacitance is used. The UVP/OVP feature compares the VADJ pin voltage to internal thresholds. If the VADJ pin voltage is lower than 90% or greater than 110% of the nominal internal reference voltage, the module is turned off, a fault is triggered, and the PGOOD pin is pulled low. When the fault hiccup interval is complete, the module will attempt to restart.

7.3.13 Enable (EN)

The EN pin provides electrical on and off control of the TPSM84A22. Once the EN pin voltage exceeds the threshold voltage, the device starts operation. If the EN pin voltage is pulled below the threshold voltage, the module stops switching and enters a low power state. There is no voltage hysteresis in the EN threshold. The rising and falling voltage thresholds occur at the same level. The EN pin has an internal pull-up current source, allowing the user to float the EN pin for enabling the device.

If an application requires controlling the EN pin, use an open drain/collector device or a suitable logic gate to interface with the pin. Figure 16 shows controlling the EN/UVLO pin using a MOSFET, Q1. Turning Q1 on, disables the device. Using a voltage supervisor to control the EN pin allows control of the turn-on and turn-off of the device as opposed to relying on the ramp up or down of the input voltage source.

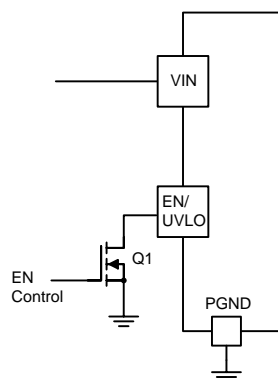

Figure 16. Enable Control

7.3.14 Undervoltage Lockout (UVLO)

The TPSM84A22 implements internal UVLO circuitry on the VIN pin. The device is disabled when the VIN pin voltage is below the internal VIN UVLO threshold. The internal VIN UVLO rising threshold is 7.65 V(max) with a typical hysteresis of 250 mV.

If an application requires a higher UVLO threshold, the UVLO pin can be configured as shown in Figure 17. The value of R_{UVLO1} and R_{UVLO2} can be calculated using Equation 3 and Equation 4 or selected from Table 2. It is recommended to set the UVLO hysteresis of approximately 500 mV in order to avoid repeated chatter during start up or shut down. Table 2 shows recommended R_{UVLO1} and R_{UVLO2} values for various VIN UVLO rising thresholds, with 500 mV of hysteresis.

$$R_{UVLO1} = \frac{V_{IN(RISE)} - V_{IN(FALL)}}{3 \mu A} \quad (3)$$

$$R_{UVLO2} = \frac{R_{UVLO1} \times 1.23}{V_{IN(FALL)} - 1.23 + (R_{UVLO1} \times 4 \mu A)} \quad (4)$$

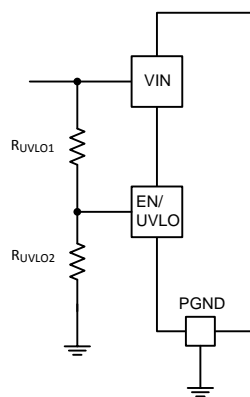

Figure 17. Adjustable UVLO

Table 2. Standard Resistor Values For Adjusting VIN UVLO

VIN UVLO RISING THRESHOLD (V)	8.0	8.5	9.0	9.5	10.0
VIN UVLO FALLING THRESHOLD (V)	7.5	8.0	8.5	9.0	9.5
R_{UVLO1} (k Ω)	169	169	169	169	169
R_{UVLO2} (k Ω)	29.4	27.4	25.5	24.3	22.6

7.4 Device Functional Modes

7.4.1 Active Mode

The TPSM84A22 is in Active Mode when VIN is above the UVLO threshold and the EN/UVLO pin voltage is above the EN high threshold. The simplest way to enable the TPSM84A22 is to leave the EN/UVLO pin floating. This allows self start-up of the TPSM84A22 when the input voltage is above the UVLO threshold.

7.4.2 Light Load Operation

The TPSM84A22 operates in forced continuous conduction mode (FCCM) under light load conditions. When operating in FCCM, the switching frequency remains constant and the high side and low side MOSFETs are turned on and off in a complementary fashion allowing negative inductor current for part of the switching cycle.

7.4.3 Shutdown Mode

The EN/UVLO pin provides electrical ON and OFF control for the TPSM84A22. When the EN/UVLO pin voltage is below the EN threshold, the device is in shutdown mode. In shutdown mode the stand-by current is typically less than 50 μA . The TPSM84A22 also employs under voltage lock out protection. If VIN is below the UVLO level, the output of the regulator turns off.

8 Application and Implementation

NOTE

Information in the following applications sections is not part of the TI component specification, and TI does not warrant its accuracy or completeness. TI's customers are responsible for determining suitability of components for their purposes. Customers should validate and test their design implementation to confirm system functionality.

8.1 Application Information

The TPSM84A22 is a synchronous series capacitor step down DC-DC power module. It is used to convert a higher DC voltage to a lower DC voltage with a maximum output current of 10 A. The following design procedure can be used to select components for the TPSM84A22. Alternately, the WEBENCH® software may be used to generate complete designs. When generating a design, the WEBENCH software utilizes an iterative design procedure and accesses comprehensive databases of components. Please visit www.ti.com/webench for more details.

8.2 Typical Application

The TPSM84A22 includes both input and output capacitors internal to the device, therefore it only requires a voltage setting resistor and possibly a pull-up resistor on the PGOOD pin in most applications. Figure 18 shows a typical TPSM84A22 schematic with only the minimum required components.

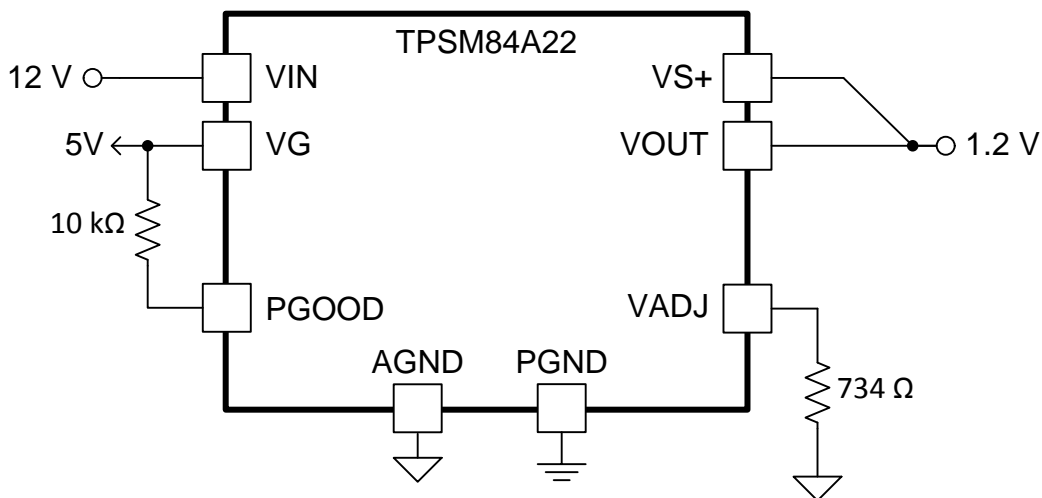

Copyright © 2016, Texas Instruments Incorporated

Figure 18. Typical Application Schematic

8.2.1 Design Requirements

For this design example, use the parameters listed in Table 3 and follow the design procedures below.

Table 3. Design Parameters

DESIGN PARAMETER	VALUE
Input Voltage V_{IN}	12 V typical
Output Voltage V_{OUT}	1.2 V
Output Current Rating	10 A
Key care-about	Transient response, small footprint, high efficiency, PGOOD signal
Transient Response Requirements	$\pm 2\%$ voltage deviation, 5 A load step, 5 A/ μ s slew rate

8.2.2 Detailed Design Procedure

8.2.2.1 Setting the Output Voltage

The output voltage of the TPSM84A22 is externally adjustable using a single resistor (R_{SET}). Select the value of R_{SET} from [Table 1](#) or calculate using [Equation 5](#):

$$R_{set} = \frac{1}{\frac{V_{out}}{0.508} - 1} (k\Omega) \quad (5)$$

To set the output voltage to 1.2 V, the calculated value for R_{SET} is 734 Ω . The closest E96 value is 732 Ω .

8.2.2.2 Input and Output Capacitance

The TPSM84A22 requires no external input or output capacitance to operate. Input and output capacitors can be added to improve ripple or transient response. However, in this design example as in many applications, no additional input or output capacitors are required.

8.2.2.3 Power Good (PGOOD)

Applications requiring voltage rail sequencing can benefit from the PGOOD signal present with the TPSM84A22. The PGOOD pin is an open drain output. When the output voltage is typically between 95% and 105% of the set point, the PGOOD pin pull-down is released and the pin floats, requiring an external pull-up resistor for a high signal. A 10-k Ω pull-up resistor is placed between the PGOOD pin and an external 5 V rail.

8.2.2.4 External VG Voltage

The VG supply rail is used to power the internal gate drivers and other internal supply rails used by the controller. For best efficiency, supply an external 5 V to the VG pin, thereby overriding the internal 4.8 V regulator. Expect a 2-3% efficiency improvement by driving the VG pin with an external 5 V.

8.2.3 Application Curves

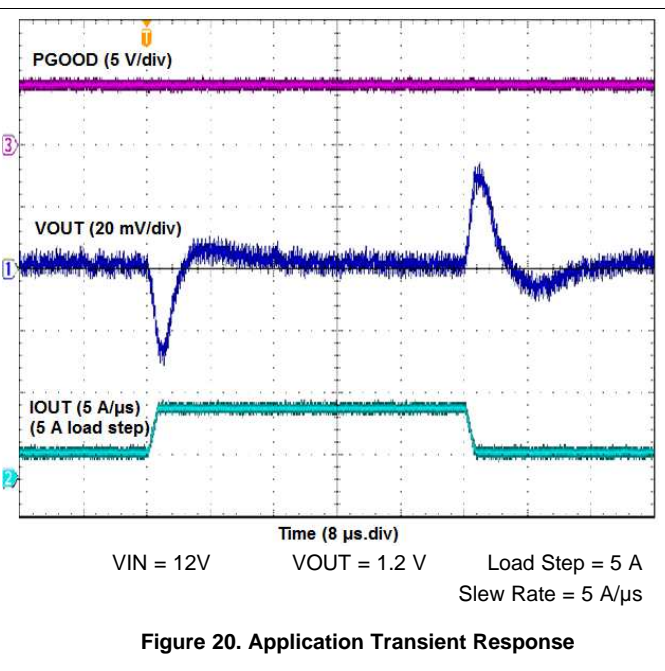
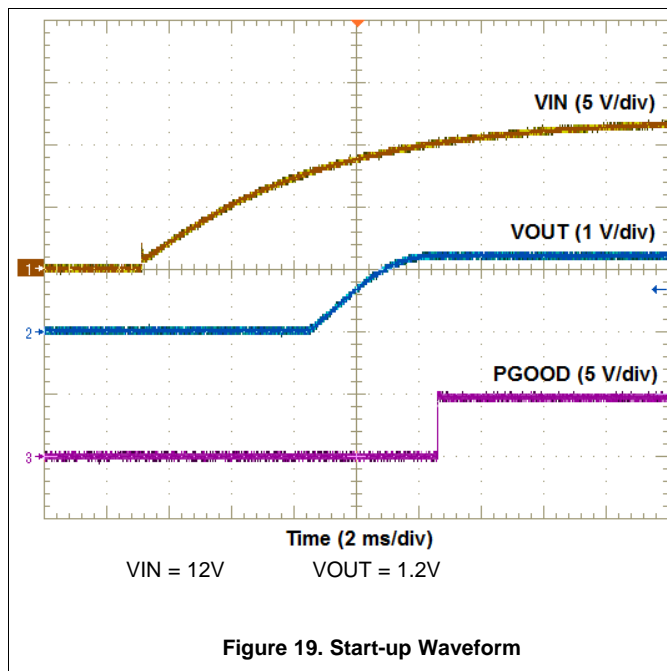

9 Power Supply Recommendations

The TPSM84A22 is designed to operate from an input voltage supply range between 8 V and 14 V. This input supply should be well regulated and able to withstand maximum input current and maintain a stable voltage. The resistance of the input supply rail should be low enough that an input current transient does not cause a high enough drop at the supply voltage that can cause a false UVLO fault triggering and system reset.

If the input supply is located more than a few inches from the TPSM84A22, additional bulk capacitance may be required at the input pins. A typical recommended amount of bulk input capacitance is 47 μF - 100 μF .

10 Layout

10.1 Layout Guidelines

To achieve optimal electrical and thermal performance, an optimized PCB layout is required. [Figure 21](#) and [Figure 23](#) show typical, top-side PCB layouts. Some considerations for an optimized layout are:

- Use large copper areas for power planes (VIN, VOUT, and PGND) to minimize conduction loss and thermal stress.
- When adding input and output ceramic capacitors, place them close to the device pins to minimize high frequency noise.
- Locate any additional output capacitors between the ceramic capacitors and the load.
- Keep AGND and PGND separate from one another. The connection is made internal to the device.
- Place R_{SET} as close as possible to the VADJ pin.
- Use multiple vias to connect the power planes to internal layers.

10.2 Layout Examples

The layout shown in [Figure 21](#) shows the minimum solution size with only a single voltage setting resistor (R1) as the only additional required component. [Figure 22](#) shows a typical internal PCB layer with a trace connecting the VS+ pin to VOUT near the load.

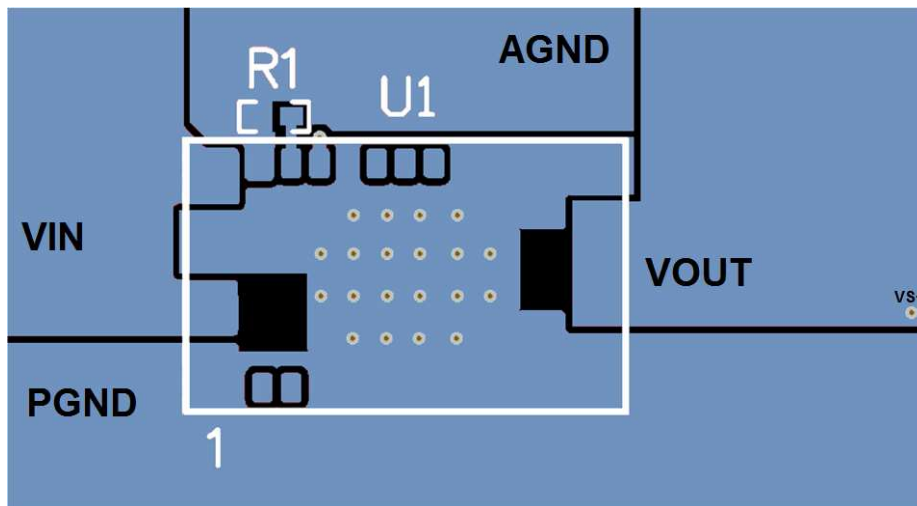

Figure 21. Minimum Component Layout

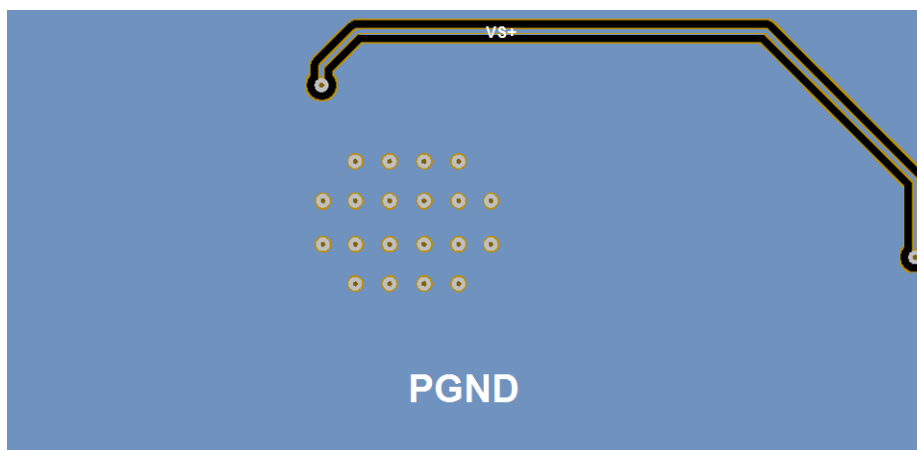

Figure 22. VS+ Trace on Internal Layer

Layout Examples (continued)

Figure 23 shows a layout with the placement of additional ceramic input capacitors (C1, C3) and ceramic output capacitors (C2, C4) for designs that require additional ripple reduction or improved transient response. Figure 24 shows a typical internal PCB layer with a trace connecting the VS+ pin to VOUT near the load.

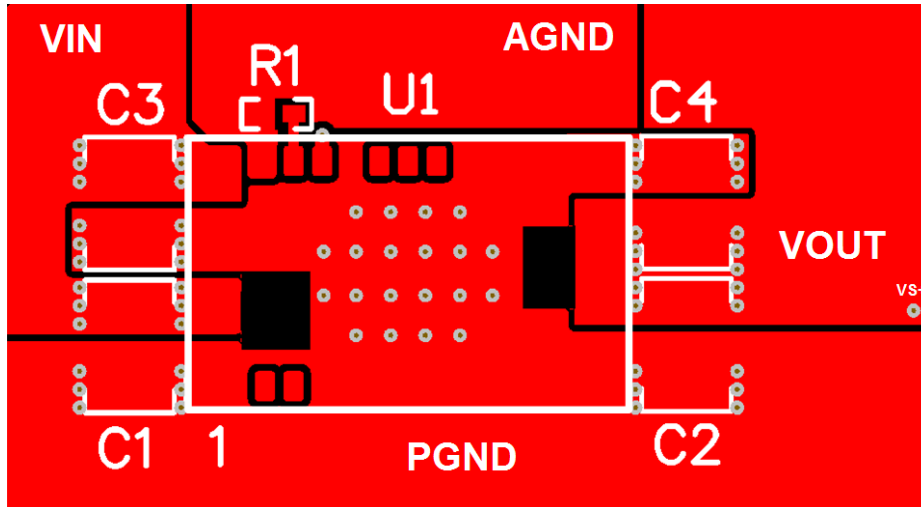

Figure 23. Layout with Optional CIN and COUT

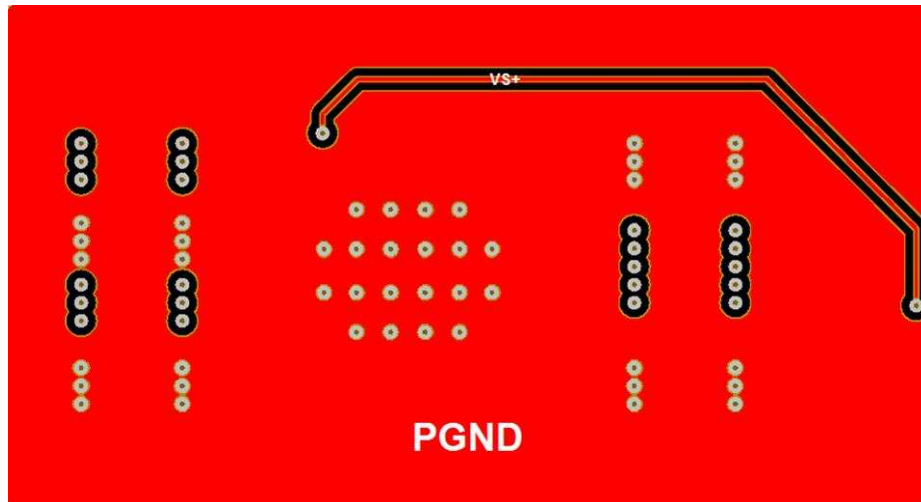

Figure 24. VS+ Trace on Internal Layer

10.3 EMI

The TPSM84A22 is compliant with EN5022 Class B radiated emissions. Figure 25 to Figure 28 show typical examples of radiated emissions plots for the TPSM84A22. Graphs included show plots of the antenna in the horizontal and vertical positions.

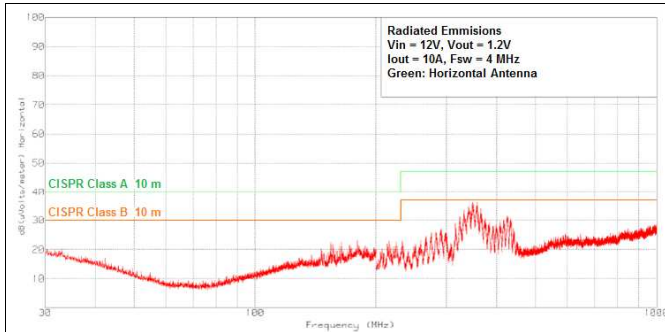

Figure 25. Radiated Emissions 12-V Input, 1.2-V Output, 10-A Load, Horizontal Antenna

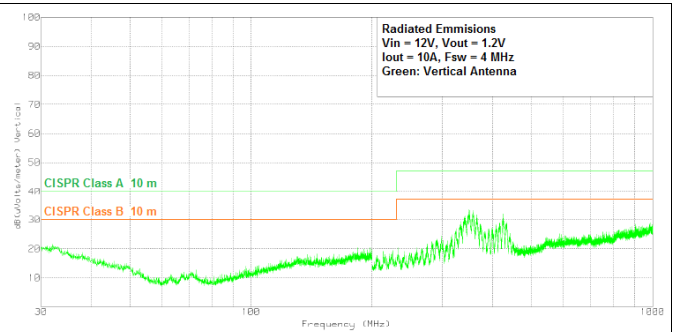

Figure 26. Radiated Emissions 12-V Input, 1.2-V Output, 10-A Load, Vertical Antenna

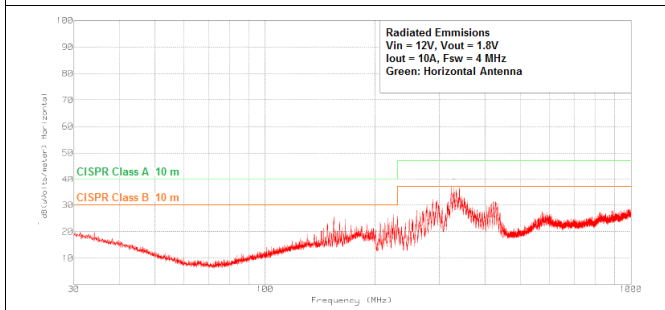

Figure 27. Radiated Emissions 12-V Input, 1.8-V Output, 10-A Load, Horizontal Antenna

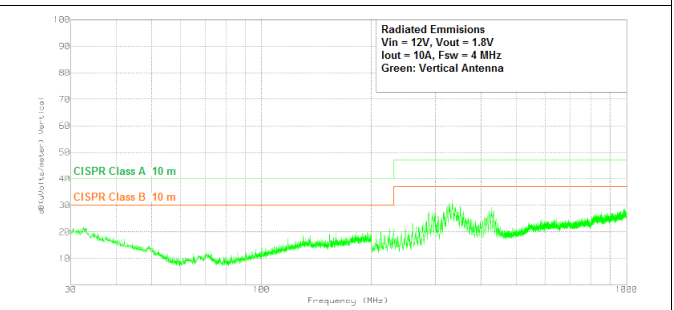

Figure 28. Radiated Emissions 12-V Input, 1.8-V Output, 10-A Load, Vertical Antenna

11 Device and Documentation Support

11.1 Documentation Support

11.1.1 Related Documentation

For related documentation see the following:

TPSM84A21 Datasheet, [SLVSDF7](#)

TPS54A20 Datasheet, [SLVSCQ8](#)

11.2 Receiving Notification of Documentation Updates

To receive notification of documentation updates, navigate to the device product folder on ti.com. In the upper right corner, click on *Alert me* to register and receive a weekly digest of any product information that has changed. For change details, review the revision history included in any revised document.

11.3 Community Resources

The following links connect to TI community resources. Linked contents are provided "AS IS" by the respective contributors. They do not constitute TI specifications and do not necessarily reflect TI's views; see TI's [Terms of Use](#).

TI E2E™ Online Community *TI's Engineer-to-Engineer (E2E) Community*. Created to foster collaboration among engineers. At e2e.ti.com, you can ask questions, share knowledge, explore ideas and help solve problems with fellow engineers.

Design Support *TI's Design Support* Quickly find helpful E2E forums along with design support tools and contact information for technical support.

11.4 Trademarks

SWIFT, E2E are trademarks of Texas Instruments.

WEBENCH is a registered trademark of Texas Instruments.

All other trademarks are the property of their respective owners.

11.5 Electrostatic Discharge Caution



These devices have limited built-in ESD protection. The leads should be shorted together or the device placed in conductive foam during storage or handling to prevent electrostatic damage to the MOS gates.

11.6 Glossary

[SLYZ022](#) — *TI Glossary*.

This glossary lists and explains terms, acronyms, and definitions.

12 Mechanical, Packaging, and Orderable Information

The following pages include mechanical, packaging, and orderable information. This information is the most current data available for the designated devices. This data is subject to change without notice and revision of this document. For browser-based versions of this data sheet, refer to the left-hand navigation.

TPSM84A22

SLVSDF8B – DECEMBER 2016 – REVISED JULY 2017

www.ti.com

12.1 Tape and Reel Information

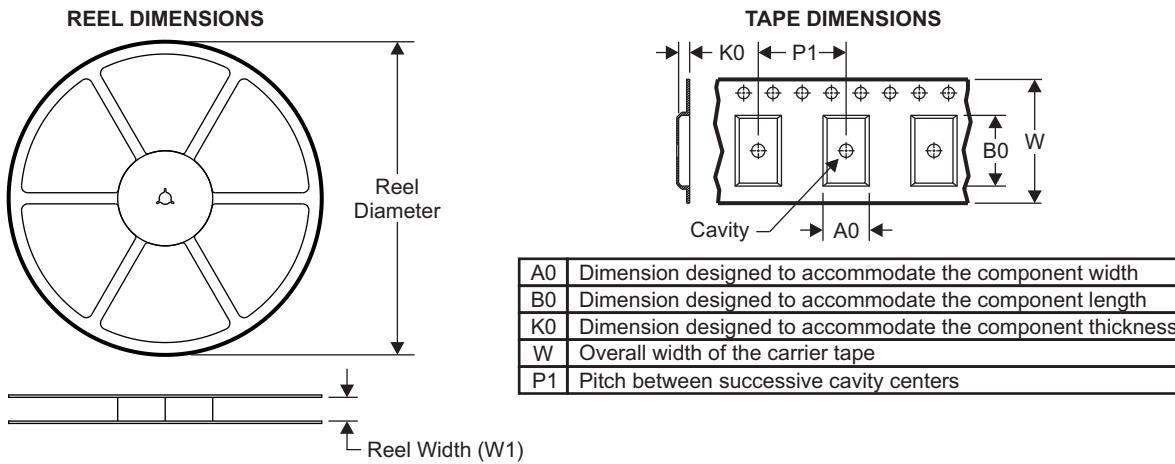

QUADRANT ASSIGNMENTS FOR PIN 1 ORIENTATION IN TAPE

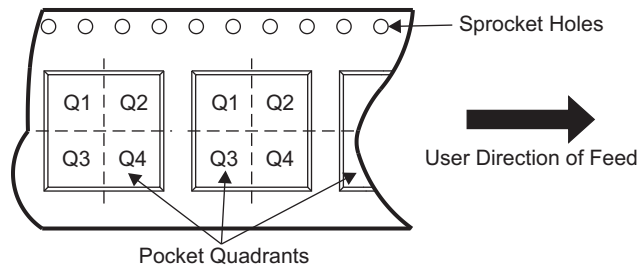

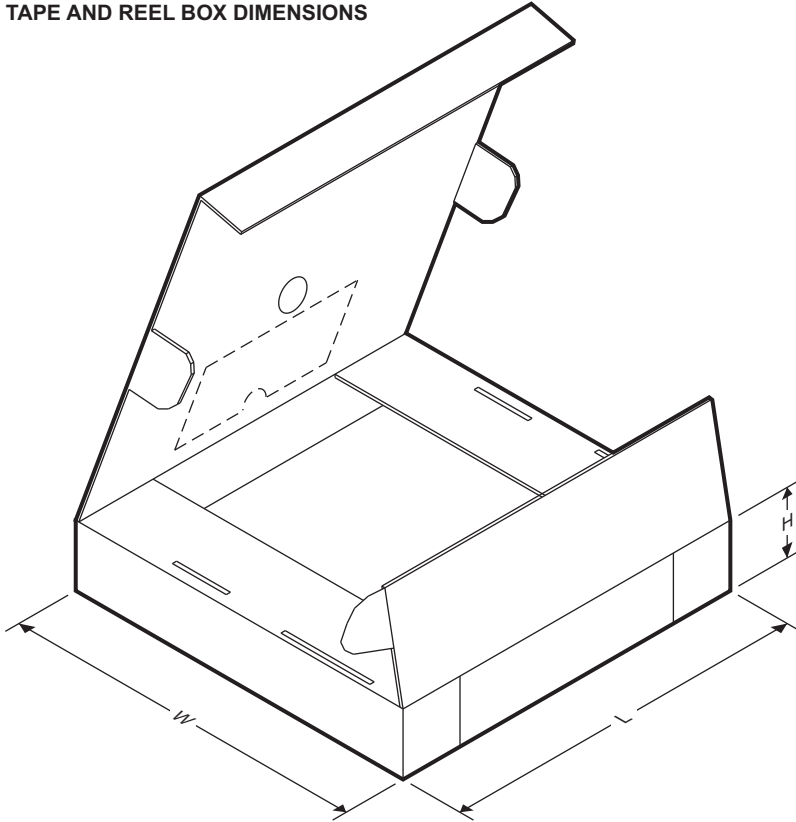

Device	Package Type	Package Drawing	Pins	SPQ	Reel Diameter (mm)	Reel Width W1 (mm)	A0 (mm)	B0 (mm)	K0 (mm)	P1 (mm)	W (mm)	Pin1 Quadrant
TPSM84A22MOJR	QFM	MOJ	20	500	330.0	24.4	9.35	15.35	3.1	16.0	24.0	Q1
TPSM84A22MOJT	QFM	MOJ	20	250	330.0	24.4	9.35	15.35	3.1	16.0	24.0	Q1

TAPE AND REEL BOX DIMENSIONS



Device	Package Type	Package Drawing	Pins	SPQ	Length (mm)	Width (mm)	Height (mm)
TPSM84A22MOJR	QFM	MOJ	20	500	383.0	353.0	58.0
TPSM84A22MOJT	QFM	MOJ	20	250	383.0	353.0	58.0

PACKAGING INFORMATION

Orderable Device	Status (1)	Package Type	Package Drawing	Pins	Package Qty	Eco Plan (2)	Lead/Ball Finish (6)	MSL Peak Temp (3)	Op Temp (°C)	Device Marking (4/5)	Samples
TPSM84A22MOJR	ACTIVE	QFM	MOJ	20	500	RoHS (In Work) & Green (In Work)	NIAU	Level-3-260C-168 HR	-40 to 85	TPSM84A22	
TPSM84A22MOJT	ACTIVE	QFM	MOJ	20	250	RoHS (In Work) & Green (In Work)	NIAU	Level-3-260C-168 HR	-40 to 85	TPSM84A22	

(1) The marketing status values are defined as follows:

ACTIVE: Product device recommended for new designs.

LIFEBUY: TI has announced that the device will be discontinued, and a lifetime-buy period is in effect.

NRND: Not recommended for new designs. Device is in production to support existing customers, but TI does not recommend using this part in a new design.

PREVIEW: Device has been announced but is not in production. Samples may or may not be available.

OBSELETE: TI has discontinued the production of the device.

(2) **RoHS:** TI defines "RoHS" to mean semiconductor products that are compliant with the current EU RoHS requirements for all 10 RoHS substances, including the requirement that RoHS substance do not exceed 0.1% by weight in homogeneous materials. Where designed to be soldered at high temperatures, "RoHS" products are suitable for use in specified lead-free processes. TI may reference these types of products as "Pb-Free".

RoHS Exempt: TI defines "RoHS Exempt" to mean products that contain lead but are compliant with EU RoHS pursuant to a specific EU RoHS exemption.

Green: TI defines "Green" to mean the content of Chlorine (Cl) and Bromine (Br) based flame retardants meet JS709B low halogen requirements of <=1000ppm threshold. Antimony trioxide based flame retardants must also meet the <=1000ppm threshold requirement.

(3) MSL, Peak Temp. - The Moisture Sensitivity Level rating according to the JEDEC industry standard classifications, and peak solder temperature.

(4) There may be additional marking, which relates to the logo, the lot trace code information, or the environmental category on the device.

(5) Multiple Device Markings will be inside parentheses. Only one Device Marking contained in parentheses and separated by a "~" will appear on a device. If a line is indented then it is a continuation of the previous line and the two combined represent the entire Device Marking for that device.

(6) Lead/Ball Finish - Orderable Devices may have multiple material finish options. Finish options are separated by a vertical ruled line. Lead/Ball Finish values may wrap to two lines if the finish value exceeds the maximum column width.

Important Information and Disclaimer:The information provided on this page represents TI's knowledge and belief as of the date that it is provided. TI bases its knowledge and belief on information provided by third parties, and makes no representation or warranty as to the accuracy of such information. Efforts are underway to better integrate information from third parties. TI has taken and continues to take reasonable steps to provide representative and accurate information but may not have conducted destructive testing or chemical analysis on incoming materials and chemicals. TI and TI suppliers consider certain information to be proprietary, and thus CAS numbers and other limited information may not be available for release.

In no event shall TI's liability arising out of such information exceed the total purchase price of the TI part(s) at issue in this document sold by TI to Customer on an annual basis.

TAPE AND REEL INFORMATION



QUADRANT ASSIGNMENTS FOR PIN 1 ORIENTATION IN TAPE



*All dimensions are nominal

Device	Package Type	Package Drawing	Pins	SPQ	Reel Diameter (mm)	Reel Width W1 (mm)	A0 (mm)	B0 (mm)	K0 (mm)	P1 (mm)	W (mm)	Pin1 Quadrant
TPSM84A22MOJR	QFM	MOJ	20	500	330.0	24.4	9.35	15.35	3.1	16.0	24.0	Q1
TPSM84A22MOJT	QFM	MOJ	20	250	330.0	24.4	9.35	15.35	3.1	16.0	24.0	Q1

TAPE AND REEL BOX DIMENSIONS

*All dimensions are nominal

Device	Package Type	Package Drawing	Pins	SPQ	Length (mm)	Width (mm)	Height (mm)
TPSM84A22MOJR	QFM	MOJ	20	500	383.0	353.0	58.0
TPSM84A22MOJT	QFM	MOJ	20	250	383.0	353.0	58.0

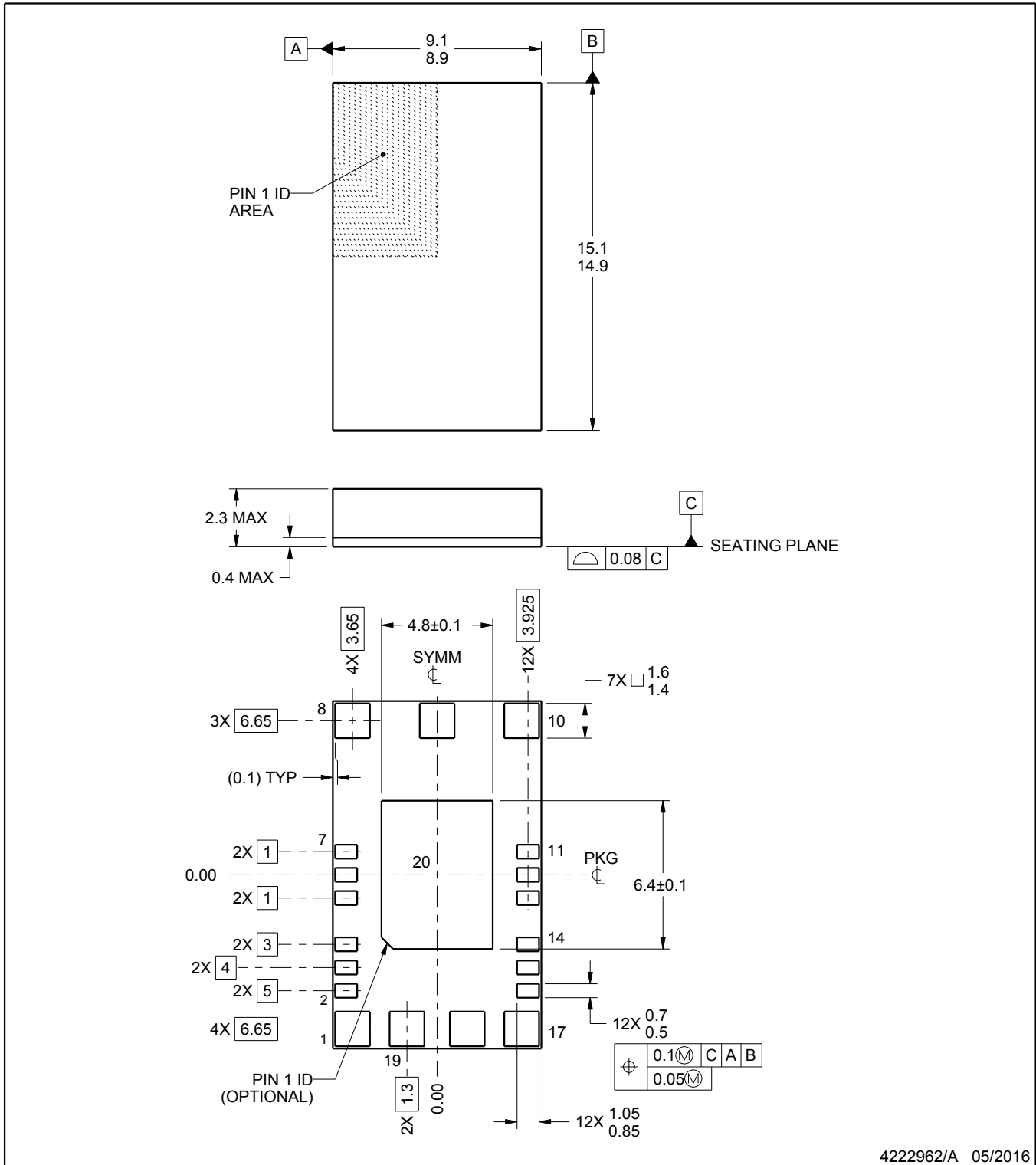
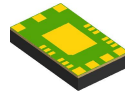

4222962/A 05/2016

NOTES:

1. All linear dimensions are in millimeters. Any dimensions in parenthesis are for reference only. Dimensioning and tolerancing per ASME Y14.5M.
2. This drawing is subject to change without notice.

EXAMPLE BOARD LAYOUT

MOJ0020A

QFM - 2.3 mm max height

QUAD FLAT MODULE

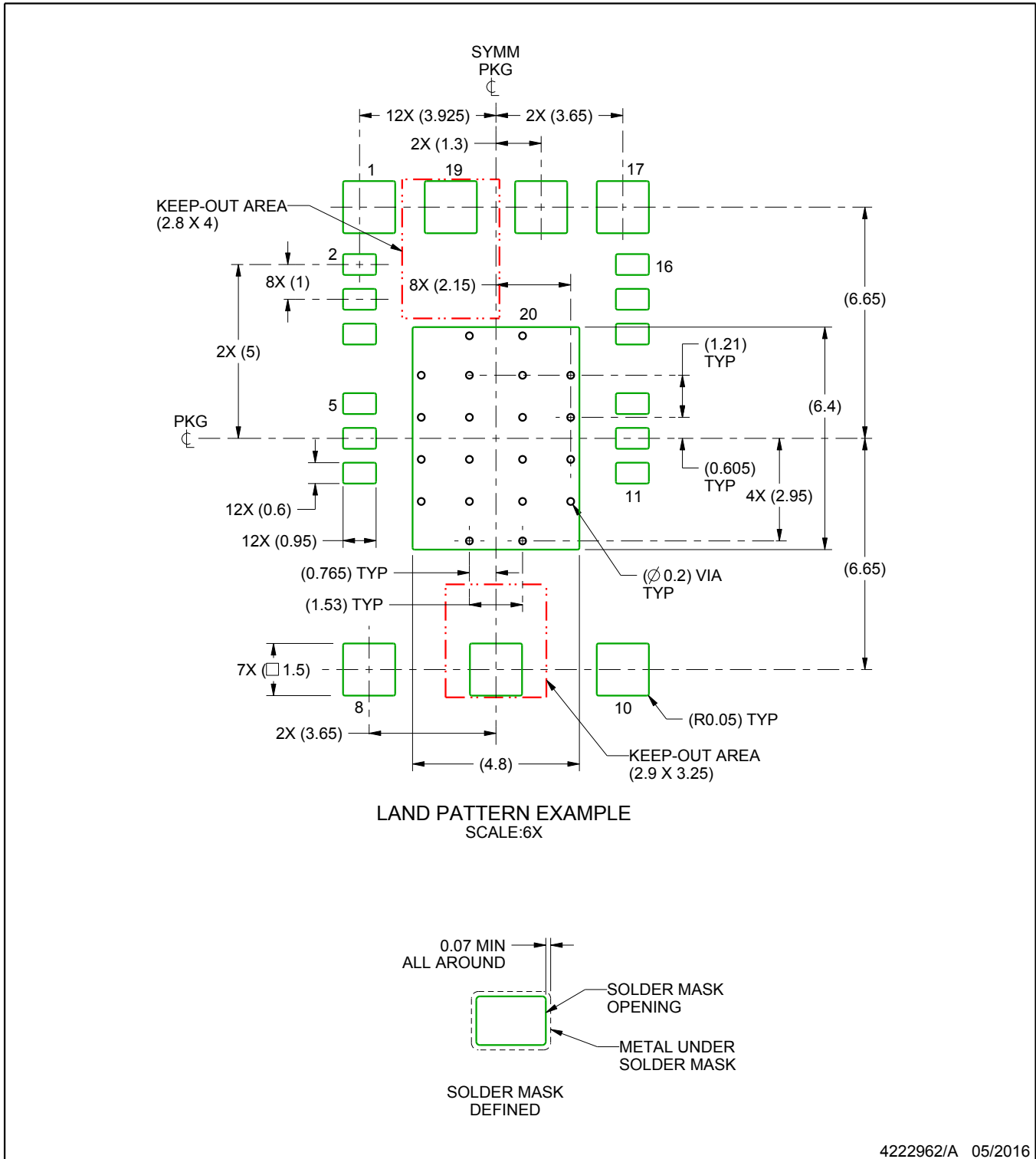

NOTES: (continued)

3. This package is designed to be soldered to thermal pads on the board. For more information, see Texas Instruments literature number SLUA271 (www.ti.com/lit/sl原因271).
4. Vias are optional depending on application, refer to device data sheet. If any vias are implemented, refer to their locations shown on this view.

EXAMPLE STENCIL DESIGN

MOJ0020A

QFM - 2.3 mm max height

QUAD FLAT MODULE

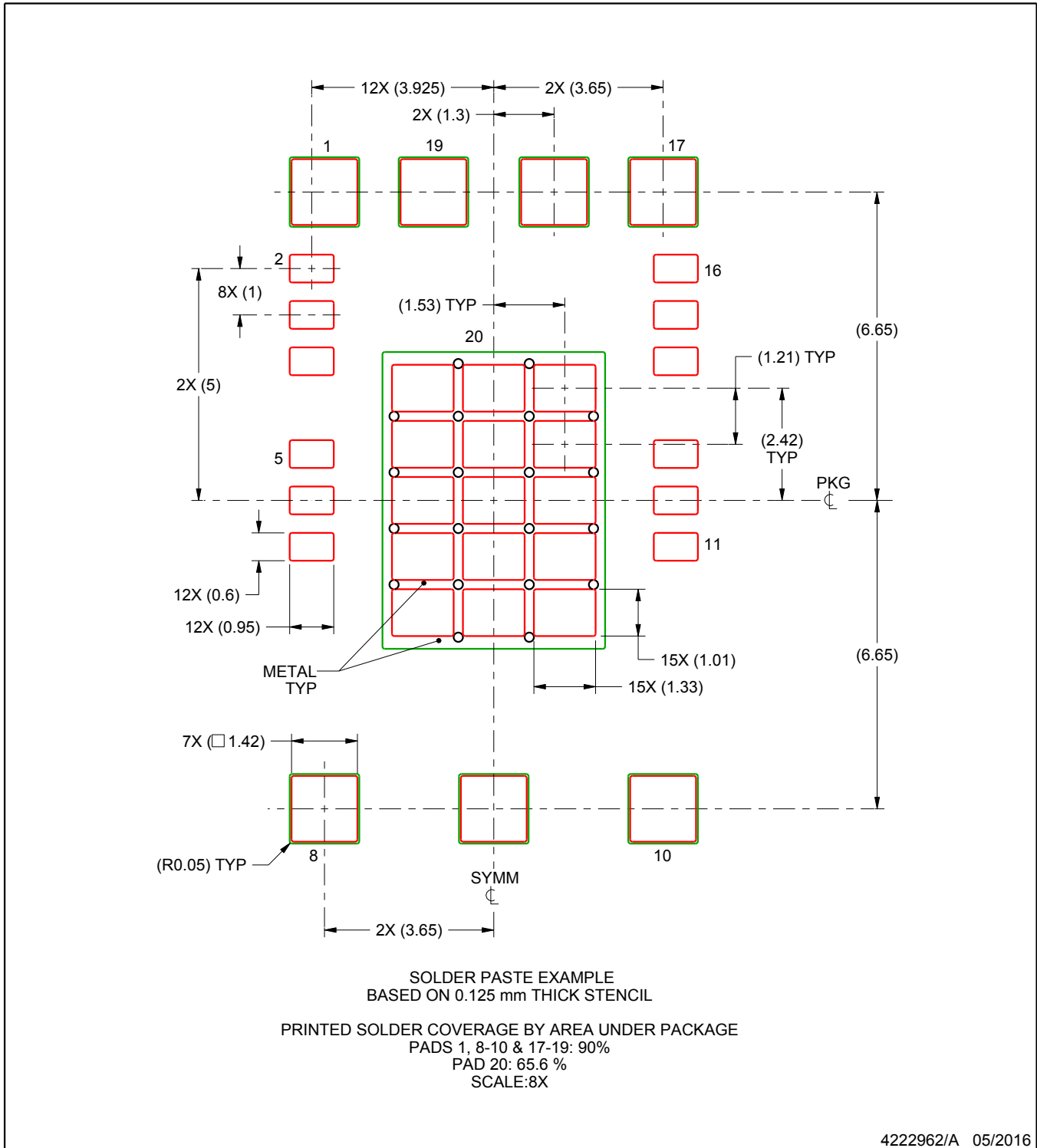

NOTES: (continued)

5. Laser cutting apertures with trapezoidal walls and rounded corners may offer better paste release. IPC-7525 may have alternate design recommendations.

IMPORTANT NOTICE AND DISCLAIMER

TI PROVIDES TECHNICAL AND RELIABILITY DATA (INCLUDING DATASHEETS), DESIGN RESOURCES (INCLUDING REFERENCE DESIGNS), APPLICATION OR OTHER DESIGN ADVICE, WEB TOOLS, SAFETY INFORMATION, AND OTHER RESOURCES "AS IS" AND WITH ALL FAULTS, AND DISCLAIMS ALL WARRANTIES, EXPRESS AND IMPLIED, INCLUDING WITHOUT LIMITATION ANY IMPLIED WARRANTIES OF MERCHANTABILITY, FITNESS FOR A PARTICULAR PURPOSE OR NON-INFRINGEMENT OF THIRD PARTY INTELLECTUAL PROPERTY RIGHTS.

These resources are intended for skilled developers designing with TI products. You are solely responsible for (1) selecting the appropriate TI products for your application, (2) designing, validating and testing your application, and (3) ensuring your application meets applicable standards, and any other safety, security, or other requirements. These resources are subject to change without notice. TI grants you permission to use these resources only for development of an application that uses the TI products described in the resource. Other reproduction and display of these resources is prohibited. No license is granted to any other TI intellectual property right or to any third party intellectual property right. TI disclaims responsibility for, and you will fully indemnify TI and its representatives against, any claims, damages, costs, losses, and liabilities arising out of your use of these resources.

TI's products are provided subject to TI's Terms of Sale (<https://www.ti.com/legal/termsofsale.html>) or other applicable terms available either on [ti.com](https://www.ti.com) or provided in conjunction with such TI products. TI's provision of these resources does not expand or otherwise alter TI's applicable warranties or warranty disclaimers for TI products.

Mailing Address: Texas Instruments, Post Office Box 655303, Dallas, Texas 75265
Copyright © 2021, Texas Instruments Incorporated





Looking for pricing, stock, or lifecycle information?

Click below to explore more details on WIN SOURCE:

 [View TPSM84A22MOJT](#) on WIN SOURCE

 [Texas Instruments](#) Information

Optimize Your Supply Chain with WIN SOURCE Solutions

-  Global Sourcing Solution
-  Obsolete Management
-  Cost Control Management
-  Shortage Management
-  Alternative Solution
-  Excess Inventory Management