



**THE DATASHEET OF
TPS65197BRUYT**



TPS65197x: 8-Channel Level-Shifter Supporting No, 2-Channel and 3-Channel Charge-Sharing with Panel Discharge to VGH during Shut-Down

1 Features

- 8-Channel Level-Shifter (STV, RESET, 6 × CLK)
- High Output-Voltage Level 16.5 V to 45 V (VGH)
- Low Output-Voltage Level Down to –20 V (VGL)
- Selectable Charge-Sharing
 - No Charge-Sharing
 - 2-Channel Charge-Sharing
 - 3-Channel Charge-Sharing
- 2-Channel Panel Discharge
- T-CON Failure Detection
 - TPS65197: Logic Resets by STV Pulse
 - TPS65197B: No Reset of the Logic
- Latched Shut-Down Detection (Clocks to VGH)
- Supports 100-kHz Clock Operating Frequency
- 28-Pin 4-mm × 4-mm QFN Package

2 Applications

- Gate-in-Panel (GIP) LCD
 - Notebook
 - Monitor
 - TV

3 Description

The TPS65197/B is an 8-channel level-shifter with discharge function intended for use in LCD display applications such as Notebooks, Monitors and TVs.

The device converts the timing-controller (T-CON) logic-level signals to the high-level signals needed by the gate-in-panel (GIP) display.

The clock outputs, CLKOUTx, support normal level shifting operation and 2-channel or 3-channel charge-sharing, which can be used to improve picture quality and power consumption. At power down, all outputs follow their input signals as long as possible; when the discharge function is used, the outputs are pulled high (V_{GH}).

The TPS65197 implements a logic reset to ignore wrong T-CON signals after the rising STV edge which forces all 6 output clocks to VGL1. The next CLKIN1 rising edge unlocks the logic and enables normal operation. The TPS65197B does not have the logic reset and always follows its input signals.

Device Information⁽¹⁾

PART NUMBER	PACKAGE	BODY SIZE (NOM)
TPS65197	WQFN (28)	4.00 mm x 4.00 mm
TPS65197B	WQFN (28)	4.00 mm x 4.00 mm

(1) For all available packages, see the orderable addendum at the end of the datasheet.

4 Simplified Schematic

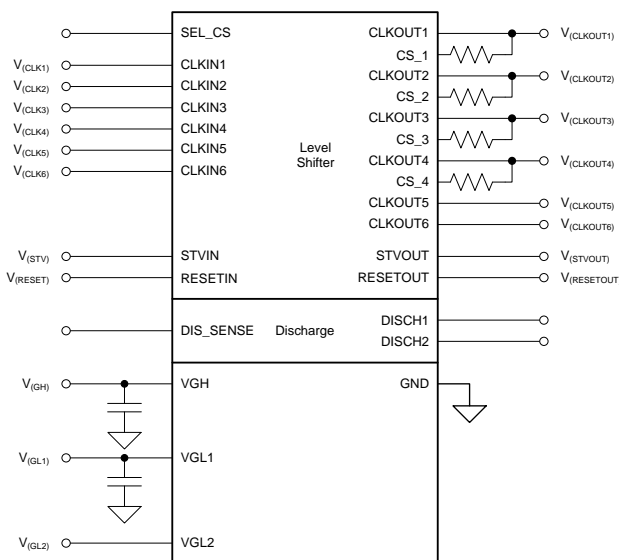

Table of Contents

1 Features	1	8.3 Feature Description	9
2 Applications	1	8.4 Device Functional Modes	10
3 Description	1	9 Application and Implementation	15
4 Simplified Schematic	1	9.1 Application Information	15
5 Revision History	2	9.2 Typical Application	15
6 Pin Configuration and Functions	3	10 Power Supply Recommendations	18
7 Specifications	4	11 Layout	19
7.1 Absolute Maximum Ratings	4	11.1 Layout Guidelines	19
7.2 ESD Ratings	4	11.2 Layout Example	19
7.3 Recommended Operating Conditions	4	12 Device and Documentation Support	20
7.4 Thermal Information	5	12.1 Documentation Support	20
7.5 Electrical Characteristics	5	12.2 Related Links	20
7.6 Switching Characteristics	6	12.3 Community Resources	20
7.7 Typical Characteristics	7	12.4 Trademarks	20
8 Detailed Description	8	12.5 Electrostatic Discharge Caution	20
8.1 Overview	8	12.6 Glossary	20
8.2 Functional Block Diagram	8	13 Mechanical, Packaging, and Orderable Information	20

5 Revision History

Changes from Revision C (May 2017) to Revision D	Page
• First public release of data sheet.	1

Changes from Revision B (July 2015) to Revision C	Page
• Changed V_{IH} MIN value from 2 to 1.65 in the INPUT SIGNALS section of the Electrical Characteristics table	5

Changes from Revision A (June 2015) to Revision B	Page
• Added TPS65197B device and changed the Simplified Schematic	1

Changes from Original (April 2012) to Revision A	Page
• Added ESD Ratings table, Timing Requirements table, Feature Description section, Device Functional Modes, Application and Implementation section, Power Supply Recommendations section, Layout section, Device and Documentation Support section, and Mechanical, Packaging, and Orderable Information sections	1
• Added TPS65197B	1
• Changed the text in the first paragraph of <i>Output Clock Behavior</i>	10
• Added Device and Documentation Support and Mechanical, Packaging, and Orderable Information sections	20

6 Pin Configuration and Functions

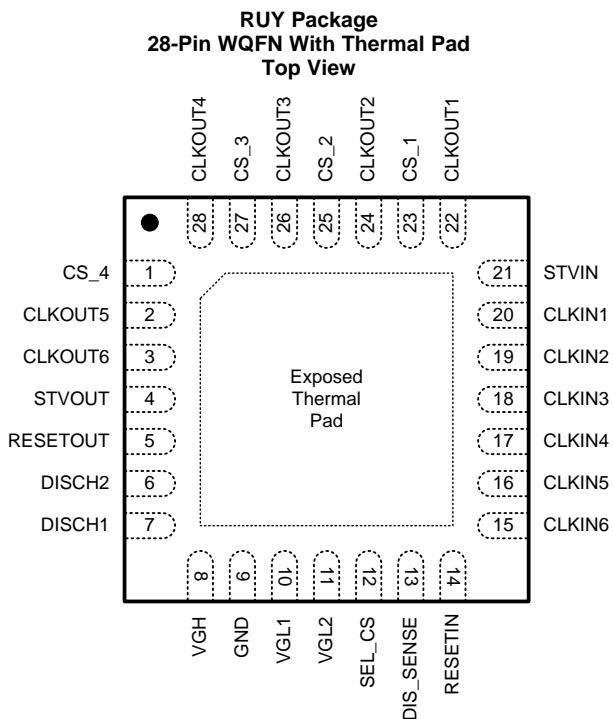

Pin Functions

PIN		I/O/P	DESCRIPTION
NAME	NUMBER		
CLKIN1	20	I	Clock 1 input
CLKIN2	19	I	Clock 2 input
CLKIN3	18	I	Clock 3 input
CLKIN4	17	I	Clock 4 input
CLKIN5	16	I	Clock 5 input
CLKIN6	15	I	Clock 6 input
CLKOUT1	22	I/O	Clock 1 output
CLKOUT2	24	I/O	Clock 2 output
CLKOUT3	26	I/O	Clock 3 output
CLKOUT4	28	I/O	Clock 4 output
CLKOUT5	2	I/O	Clock 5 output
CLKOUT6	3	I/O	Clock 6 output
CS_1	23	I/O	Clock 1 charge-sharing input
CS_2	25	I/O	Clock 2 charge-sharing input
CS_3	27	I/O	Clock 3 charge-sharing input
CS_4	1	I/O	Clock 4 charge-sharing input
DISCH1	7	I/O	Discharge 1 output. Internally connected to VGL1 and VGH
DISCH2	6	I/O	Discharge 2 output. Internally connected to VGL2 and VGH
DIS_SENSE	13	I	Discharge sense terminal
GND	9	–	Ground
RESETIN	14	I	RESET input
RESETOUT	5	I/O	RESET output

Pin Functions (continued)

PIN		I/O/P	DESCRIPTION
NAME	NUMBER		
SEL_CS	12	I	Charge-sharing method-selection terminal. When left floating or pulled to GND, charge-sharing is disabled.
STVIN	21	I	STV input
STVOUT	4	I/O	STV output
VGH	8	P	Positive supply voltage. Place a buffer capacitor close to this terminal.
VGL1	10	P	Negative supply voltage for all outputs except discharge 2. Place a buffer capacitor close to this terminal.
VGL2	11	P	Negative supply voltage for discharge 2
Thermal pad	–	–	The thermal pad is connected to VGL1.

7 Specifications

7.1 Absolute Maximum Ratings

over operating free-air temperature range (unless otherwise noted)

	MIN	MAX	UNIT	
Terminal voltage ⁽¹⁾	SEL_CS, DIS_SENSE, CLKIN1, CLKIN2, CLKIN3, CLKIN4, CLKIN5, CLKIN6, STVIN, RESETIN	–0.3	7	V
	VGH	–0.3	50	
	VGL1, VGL2	–25	0.3	
	CLKOUT1, CLKOUT2, CLKOUT3, CLKOUT4, CLKOUT5, CLKOUT6, CS_1, CS_2, CS_3, CS_4, STVOUT, RESETOUT, DISCH1, DISCH2	–25	50	
	VGH – VGLx		62	
	VGL1 – VGL2	–20	0	
Operating junction temperature, T _J	–40	150	°C	
Storage temperature, T _{stg}	–65	150		

(1) With respect to the GND terminal

7.2 ESD Ratings

	VALUE	UNIT	
V _(ESD) Electrostatic discharge	Human-body model (HBM), per ANSI/ESDA/JEDEC JS-001 ⁽¹⁾	±2000	V
	Charged-device model (CDM), per JEDEC specification JESD22-C101 ⁽²⁾	±700	

(1) JEDEC document JEP155 states that 500-V HBM allows safe manufacturing with a standard ESD control process.

(2) JEDEC document JEP157 states that 250-V CDM allows safe manufacturing with a standard ESD control process.

7.3 Recommended Operating Conditions

over operating free-air temperature range (unless otherwise noted)

	MIN	NOM	MAX	UNIT
V _(GH) Voltage range of positive supply	16.5		45	V
V _(GL_x) Voltage range of negative supply	–20		–3	
V _(GH) – V _(GL_x) Voltage difference between V _(GH) and V _(GL_x)	0		60	
V _{GL1} – V _{GL2} Voltage difference between V _(GL1) and V _(GL2) (V _(GL1) must be more negative than V _(GL2))	–20		0	
T _A Operating free-air temperature	–40		85	°C
T _J Operating junction temperature	–40		125	

7.4 Thermal Information

THERMAL METRIC ⁽¹⁾		TPS65197/B	UNIT
		RUY	
		28 PINS	
R _{θJA}	Junction-to-ambient thermal resistance	34.5	°C/W
R _{θJctop}	Junction-to-case (top) thermal resistance	25.5	
R _{θJB}	Junction-to-board thermal resistance	7.5	
ψ _{JT}	Junction-to-top characterization parameter	0.2	
ψ _{JB}	Junction-to-board characterization parameter	7.5	
R _{θJcbot}	Junction-to-case (bottom) thermal resistance	2.5	

(1) For more information about traditional and new thermal metrics, see the *Semiconductor and IC Package Thermal Metrics* application report, [SPRA953](#).

7.5 Electrical Characteristics

V_(GH) = 30 V, V_(GL1) = -10 V, V_(GL2) = -8 V, T_A = -40°C to 85°C, typical values are at T_A = 25°C (unless otherwise noted)

PARAMETER		TEST CONDITIONS	MIN	TYP	MAX	UNIT
V _(GH)	Input voltage range V _(GH)		16.5		45	V
V _(GL1)	Input voltage range V _(GL1)		-20		-3	
V _(GL2)	Input voltage range V _(GL2)		-20		-3	
I _(GH)	Positive supply current			0.3	1	mA
I _(GL1)	Negative supply current	CLKINx = STVIN = RESETIN = SEL_CS = 0 V, DIS_SENSE = 5 V	-0.5	-0.05		
I _(GL2)	Negative supply current		-0.5	-0.05		
V _(UVLO)	Undervoltage lockout threshold	V _(GH) rising, T _J = -40°C to 85°C	13.5	15	16.5	V
		V _(GH) falling, T _J = -40°C to 85°C	2	3.5	5	
T _(SD)	Thermal shutdown temperature	T _J rising	130	150	170	°C
INPUT SIGNALS (CLKINx, STVIN, RESETIN, SEL_CS, DIS_SENSE)						
V _{IH}	High-level input voltage CLKINx, STVIN, RESETIN	Input rising	1.65			V
V _{IL}	Low-level input voltage CLKINx, STVIN, RESETIN	Input falling			0.8	
V _(SEL_CS)	Charge-sharing-disabled voltage				0.5	
	3-Channel Charge-Sharing voltage		1		2	
	2-Channel Charge-Sharing voltage		2.8		6.5	
V _(DIS_SENSE)	Discharge detection threshold	V _(DIS_SENSE) falling, T _J = 0°C to 85°C	1.17	1.26	1.36	
I _{IN}	Input current CLKINx, STVIN, RESETIN, DIS_SENSE	CLKINx = STVIN = RESETIN = DIS_SENSE = 5 V		2	100	nA
	Input current SEL_CS	SEL_CS = 5 V		50	100	µA
R _(SEL_CS)	SEL_CS pin, internal pulldown resistance		50	100	150	kΩ
LEVEL SHIFTERS (CLKOUT1 to CLKOUT6)						
r _{DS(on)}	High-side on-resistance, CLKOUTx	I _(OUT) = 10 mA, sourcing (high side)		11	25	Ω
	Low-side on-resistance, CLKOUTx	I _(OUT) = 10 mA, sinking (low side)		7	15	
R _(CS)	Internal charge-sharing resistance	I _(CS) = 10 mA, T _J = -40°C to 85°C	30	60	100	
LEVEL SHIFTERS (STVOUT, RESETOUT)						
r _{DS(on)}	High-side on-resistance STVOUT, RESETOUT	I _(OUT) = 10 mA, sourcing (high side)		30	60	Ω
	Low-side on-resistance STVOUT, RESETOUT	I _(OUT) = 10 mA, sinking (low side)		15	30	

Electrical Characteristics (continued)

$V_{(GH)} = 30\text{ V}$, $V_{(GL1)} = -10\text{ V}$, $V_{(GL2)} = -8\text{ V}$, $T_A = -40^\circ\text{C}$ to 85°C , typical values are at $T_A = 25^\circ\text{C}$ (unless otherwise noted)

PARAMETER		TEST CONDITIONS	MIN	TYP	MAX	UNIT
DISCHARGE OUTPUTS (DISCH1, DISCH2)						
$r_{DS(on)}$	High-side on-resistance, DISCH1	$I_{(OUT)} = 10\text{ mA}$, sourcing (high side)		14	60	Ω
	Low-side on-resistance DISCH1	$I_{(OUT)} = 10\text{ mA}$, sinking (low side)		3	10	
	High-side on-resistance, DISCH2	$I_{(OUT)} = 10\text{ mA}$, sourcing (high side)		14	60	
	Low-side on-resistance DISCH2	$I_{(OUT)} = 10\text{ mA}$, sinking (low side)		10	20	

7.6 Switching Characteristics

over operating free-air temperature range (unless otherwise noted)

			MIN	NOM	MAX	UNIT
LEVEL SHIFTERS (CLKOUT1 to CLKOUT6)						
Slew+	Slew rate, rising	$C_{(OUT)} = 4.7\text{ nF}$, $V_{(OUT)} = 20\%$ to 80%	50	140		$\text{V}/\mu\text{s}$
Slew-	Slew rate, falling		50	150		
t_{dr}	Propagation delay	$V_{(OUT)}$ rising, $C_{(OUT)} = 150\text{ pF}$		40	100	ns
t_{df}		$V_{(OUT)}$ falling, $C_{(OUT)} = 150\text{ pF}$		50	100	
$t_{dr(CS)}$		$V_{(OUT)}$ rising, $C_{(OUT)} = 150\text{ pF}$, $R_{(CS)} = 50\ \Omega$		50	150	
$t_{df(CS)}$		$V_{(OUT)}$ falling, $C_{(OUT)} = 150\text{ pF}$, $R_{(CS)} = 50\ \Omega$		70	150	
LEVEL SHIFTERS (STVOUT, RESETOUT)						
Slew+	Slew rate, rising	$C_{(OUT)} = 4.7\text{ nF}$, $V_{(OUT)} = 20\%$ to 80%	20	50		$\text{V}/\mu\text{s}$
Slew-	Slew rate, falling		30	60		
t_{dr}	Propagation delay	$V_{(OUT)}$ rising, $C_{(OUT)} = 150\text{ pF}$		40	100	ns
t_{df}		$V_{(OUT)}$ falling, $C_{(OUT)} = 150\text{ pF}$		50	100	

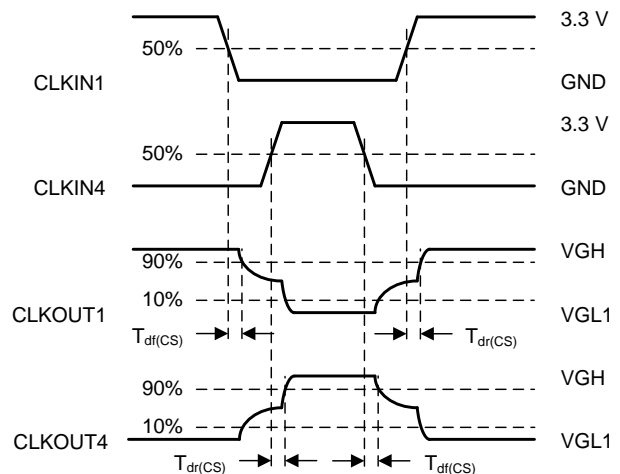
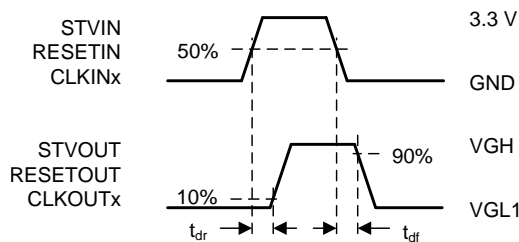
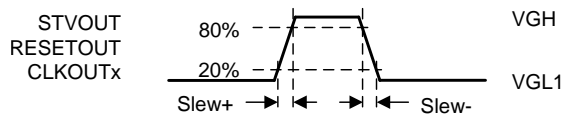

7.7 Typical Characteristics

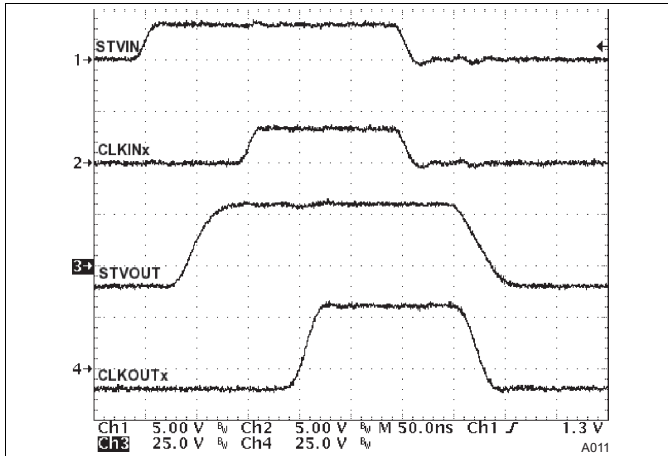

Figure 1. Propagation Delay, Charge Sharing Disabled

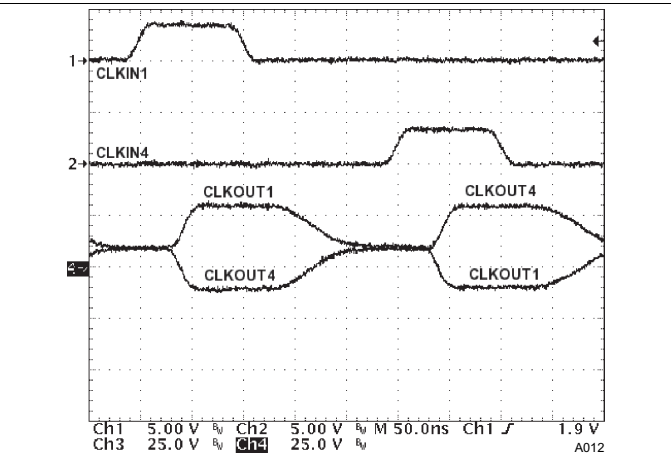

Figure 2. Propagation Delay, Charge Sharing Enabled

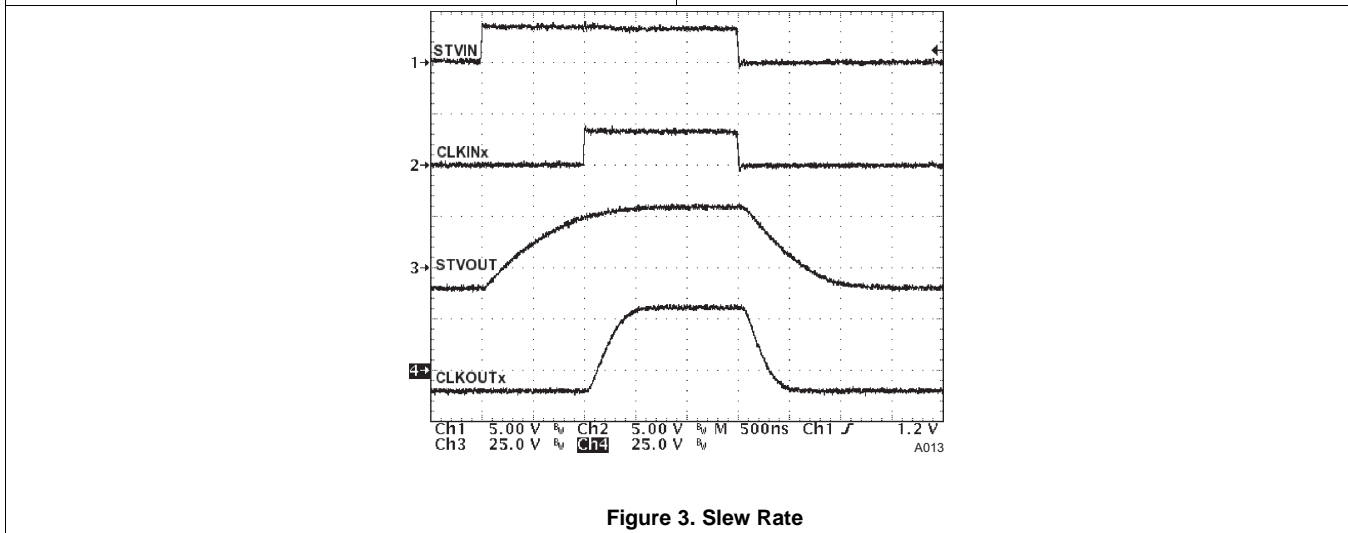

Figure 3. Slew Rate

8 Detailed Description

8.1 Overview

The TPS65197/B is a 8-channel level-shifter with optional discharge function during shut-down. It supports no charge-sharing as well as 2-channel and 3-channel charge-sharing. Two channels are used to generate the STV and RESET signal, the remaining 6 channels generate the clocks. The two discharge outputs (DISCH1 and DISCH2) are connected to VGL1 and VGL2 during operation, at shutdown both discharge outputs are connected to VGH.

8.2 Functional Block Diagram

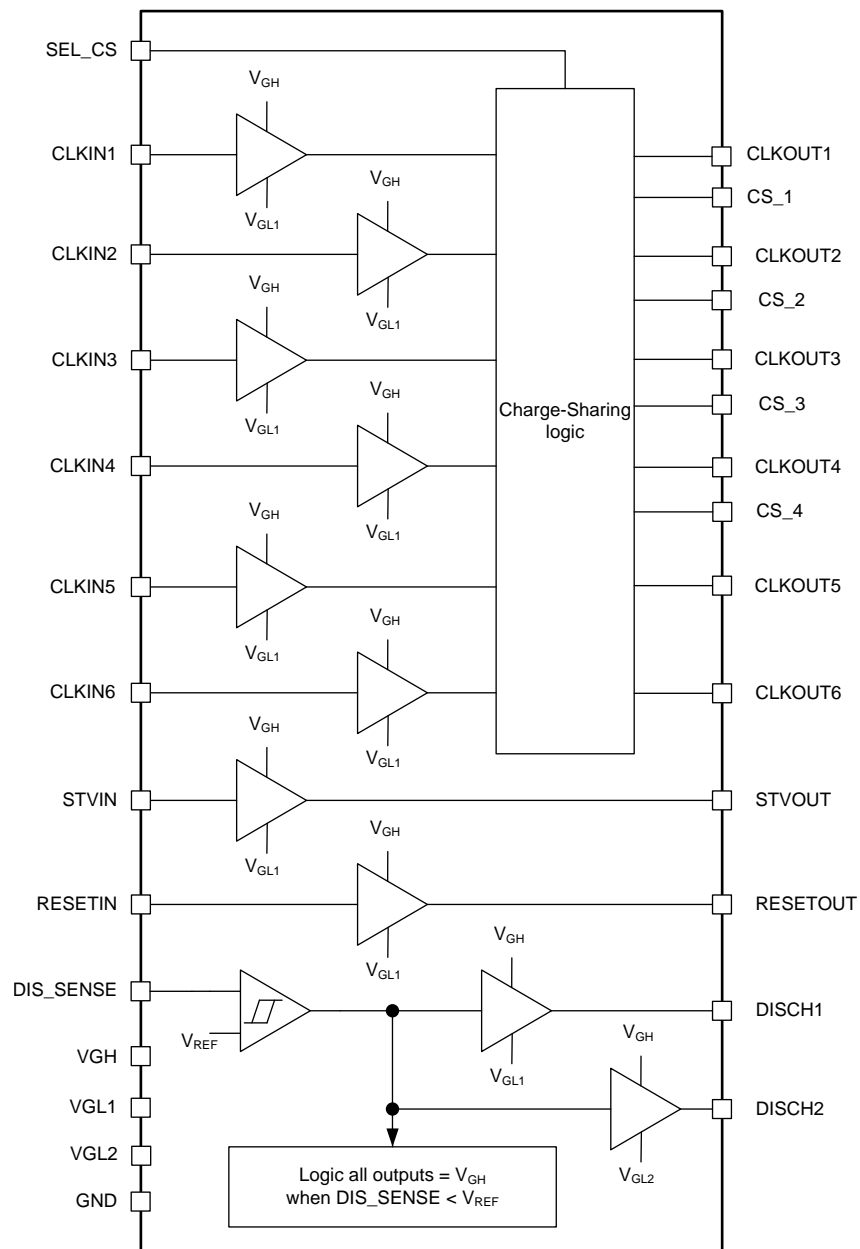

8.3 Feature Description

8.3.1 Sequencing

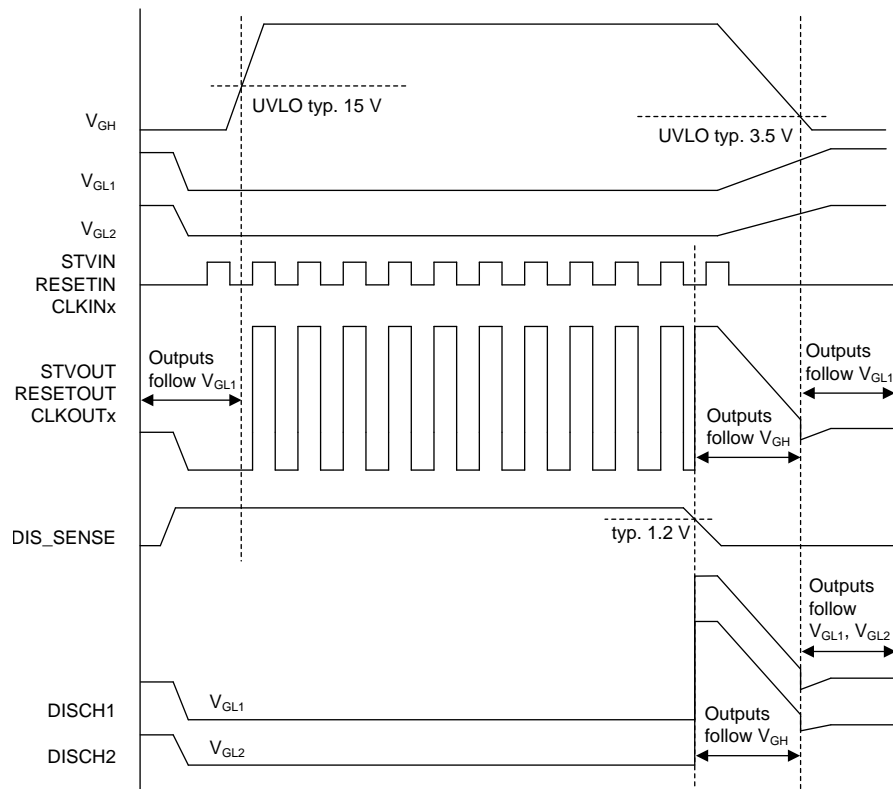

8.3.2 Power Up

At power up V_{GL1} and V_{GL2} must be present before V_{GH} is rising. V_{GL1} must be always more negative or equal to V_{GL2} . V_{GH} should not rise faster than in 100 μ s. All clock output channels and DISCH1 follow V_{GL1} , DISCH2 follows V_{GL2} until V_{GH} rises above its rising UVLO threshold voltage of 15 V, then all clock output channels of the TPS65197B follow their input signals. The TPS65197 has a different startup behavior as CLKOUT1 to CLKOUT6 are forced to V_{GL1} until the 1st rising edge of CLKIN1 releases all clocks. The discharge-sense (DIS_SENSE) voltage must be higher than its maximum threshold voltage of 1.36 V before V_{GH} reaches the rising UVLO threshold of 15 V, otherwise all outputs are forced to V_{GH} and the state is latched. The selected Charge-Sharing method is latched when V_{GH} reaches the rising UVLO according to the SEL_CS voltage, it is reset with the falling UVLO.

8.3.3 Power Down

When the discharge-sense (DIS_SENSE) voltage falls below its typical threshold voltage of 1.26 V, all clock output channels follow V_{GH} until V_{GH} falls below its typical falling UVLO threshold voltage of 3.5 V; then all clock output channels and DISCH1 follow V_{GL1} , DISCH2 follows V_{GL2} . Once discharge-sense is triggered the state is latched, to reset and continue normal operation V_{GH} has to fall below the falling UVLO threshold of 3.5 V.

In case the discharge-sense (DIS_SENSE) voltage stays high during power down, all clock output channels follow their input signals until V_{GH} falls below its typical falling UVLO threshold voltage of 3.5 V; then all clock output channels follow V_{GL1} . The discharge channels follow V_{GL1} and V_{GL2} all the time.

8.3.4 Disabling the Discharge Function

When the discharge function is not used, the DIS_SENSE pin must be pulled above its maximum threshold voltage of 1.36 V all the time (for example to 3.3 V).

Feature Description (continued)

8.3.5 Undervoltage Lockout

To avoid improper operation of the device at low input voltages, an undervoltage lockout function is implemented. When V_{GH} is below the UVLO threshold each output channel is clamped to its respective negative supply, V_{GL1} or V_{GL2} .

8.3.6 Thermal Shutdown

A thermal shutdown is implemented to prevent damage because of excessive heat or power dissipation. Once the junction temperature exceeds a typical value of 150 °C, all outputs are set to high-impedance. This state is latched. V_{GH} must fall below the falling UVLO (3.5 V) to reset the thermal shutdown.

8.4 Device Functional Modes

8.4.1 Output Clock Behavior

The STV and RESET channels always follow their inputs while the clocks 1 to 6 behave different for TPS65197 and TPS65197B.

TPS65197:

At startup the output signals CLKOUT1 to CLKOUT6 are forced low (V_{GL1}) until the first rising edge of CLKOUT1 releases all clocks. Every rising edge of STVIN stops the Charge-Sharing and resets the output signals CLKOUT1 to CLKOUT6 (that is, forced low) until the next rising edge of CLKIN1 after which the clock outputs follow their inputs again. The rising edge of CLKIN1 should occur not sooner than 50 ns after the rising edge of STVIN. This logic ensures a proper reset and a clean start every frame.

TPS65197B:

The TPS65197B does not have the reset logic as TPS65197 and all outputs always follow their input signals (also at startup). If Charge-Sharing is activated every rising edge of STVIN stops the Charge-Sharing and the output signals CLKOUT1 to CLKOUT6 follow their input signals. The next Charge-Sharing event should not occur sooner than 50 ns after the rising edge of STVIN.

Device Functional Modes (continued)

8.4.2 Charge-Sharing Methods TPS65197

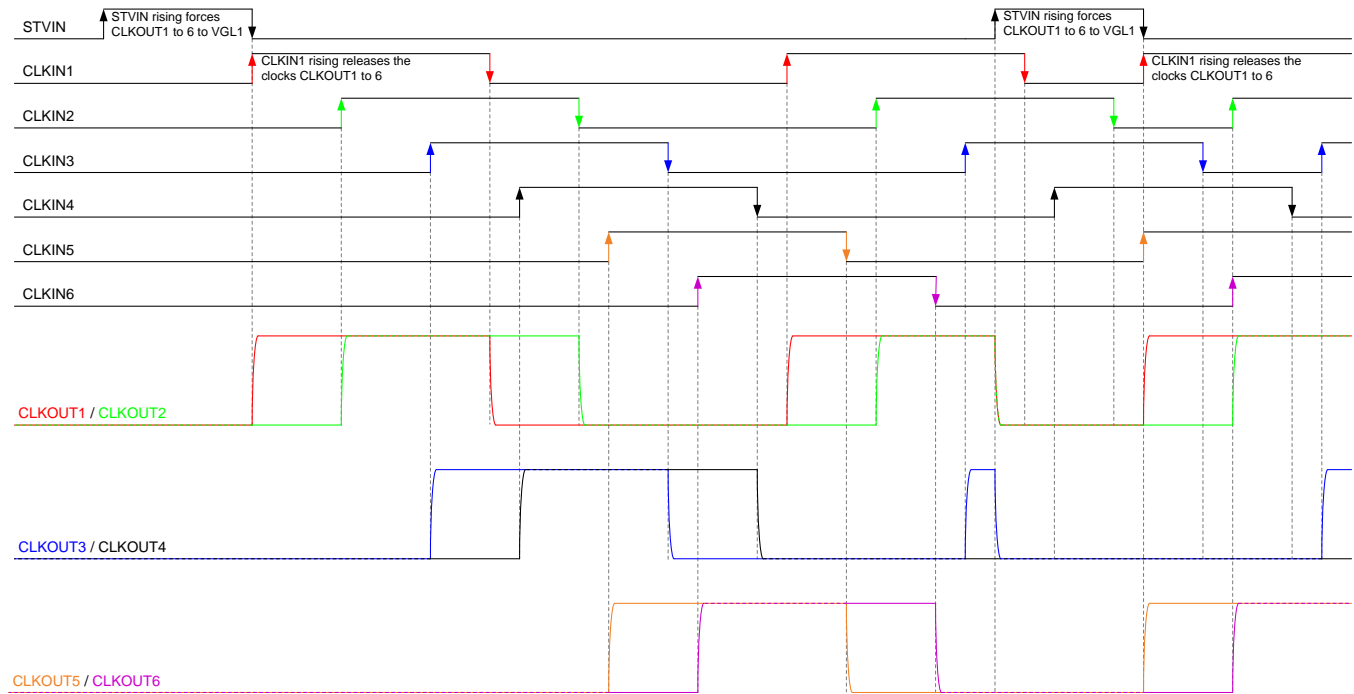
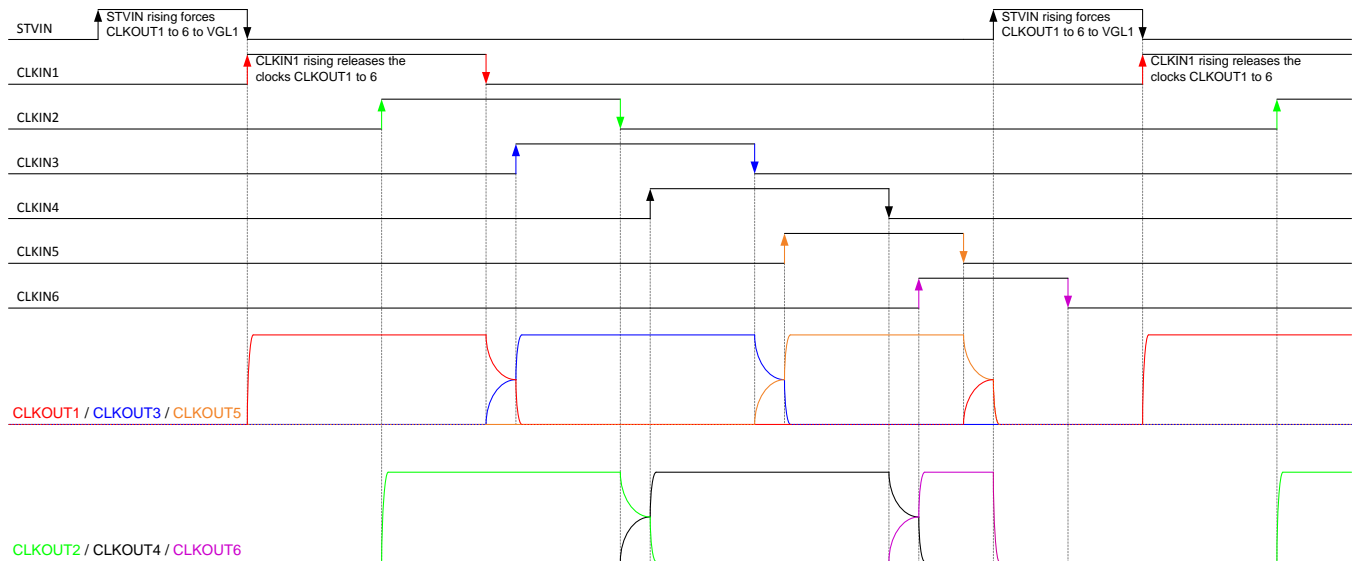
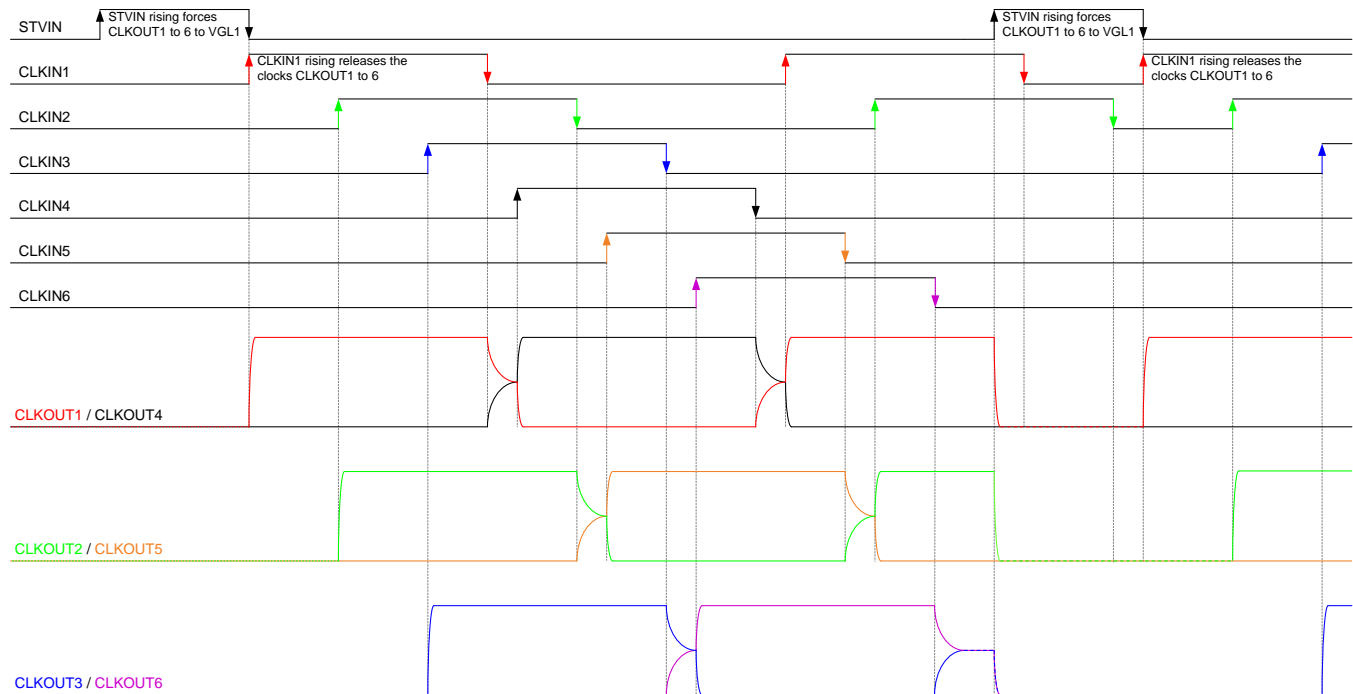

Figure 4. TPS65197: Charge-Sharing Disabled ($CS_SEL < 0.5\text{ V}$)



Charge-sharing of CLKOUT1 ↔ CLKOUT3 between CLKIN1↓ CLKIN3↑.
 Charge-sharing of CLKOUT3 ↔ CLKOUT5 between CLKIN3↓ CLKIN5↑.
 Charge-sharing of CLKOUT5 ↔ CLKOUT1 between CLKIN5↓ CLKIN1↑.
 Charge-sharing of CLKOUT2 ↔ CLKOUT4 between CLKIN2↓ CLKIN4↑.
 Charge-sharing of CLKOUT4 ↔ CLKOUT6 between CLKIN4↓ CLKIN6↑.
 Charge-sharing of CLKOUT6 ↔ CLKOUT2 between CLKIN6↓ CLKIN2↑.

Figure 5. TPS65197: 3-Channel Charge-Sharing ($CS_SEL = 1\text{ V} \dots 2\text{ V}$)

Device Functional Modes (continued)

Charge-sharing of CLKOUT1 ↔ CLKOUT4 between CLKIN1↓ CLKIN4↑ and CLKIN4↓ CLKIN1↑.

Charge-Sharing of CLKOUT2 ↔ CLKOUT5 between CLKIN2↓ CLKIN5↑ and CLKIN5↓ CLKIN2↑.

Charge-Sharing of CLKOUT3 ↔ CLKOUT6 between CLKIN3↓ CLKIN6↑ and CLKIN6↓ CLKIN3↑.

Figure 6. TPS65197: 2-Channel Charge-Sharing (CS_SEL = 2.8 V...6.5 V)

Device Functional Modes (continued)

8.4.3 Charge-Sharing Methods TPS65197B

TPS65197B:

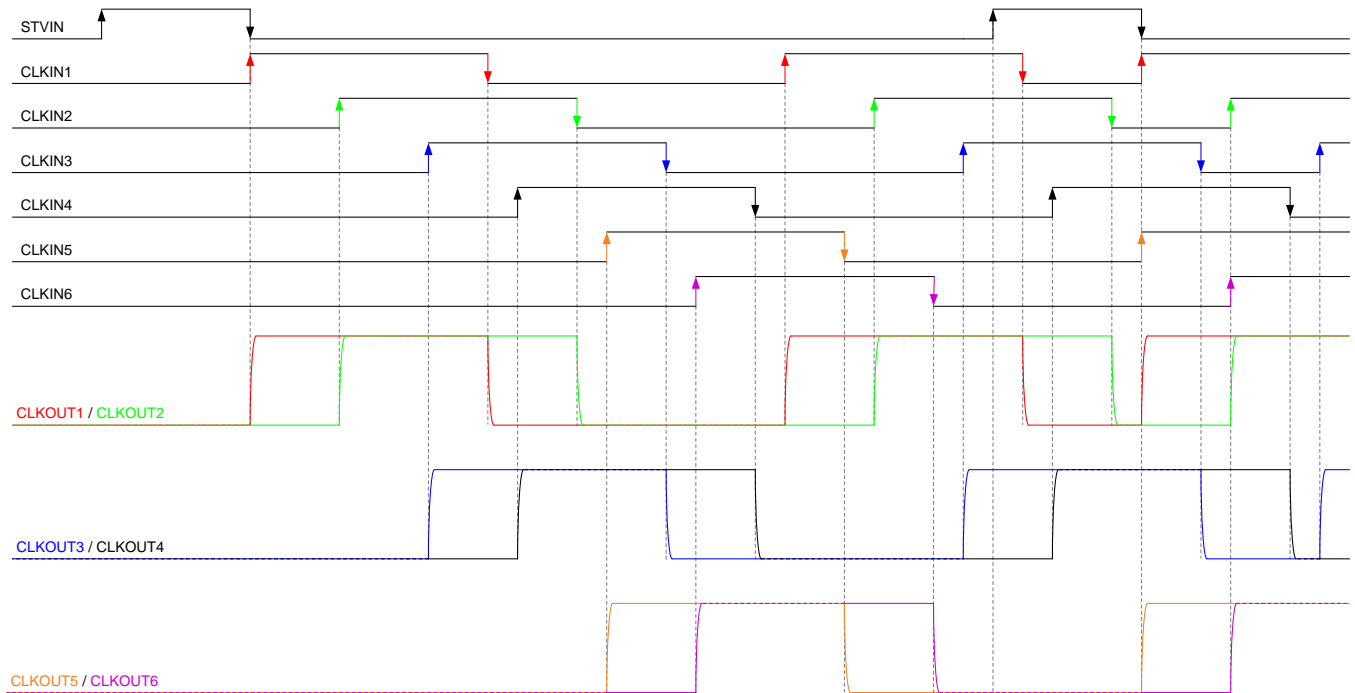
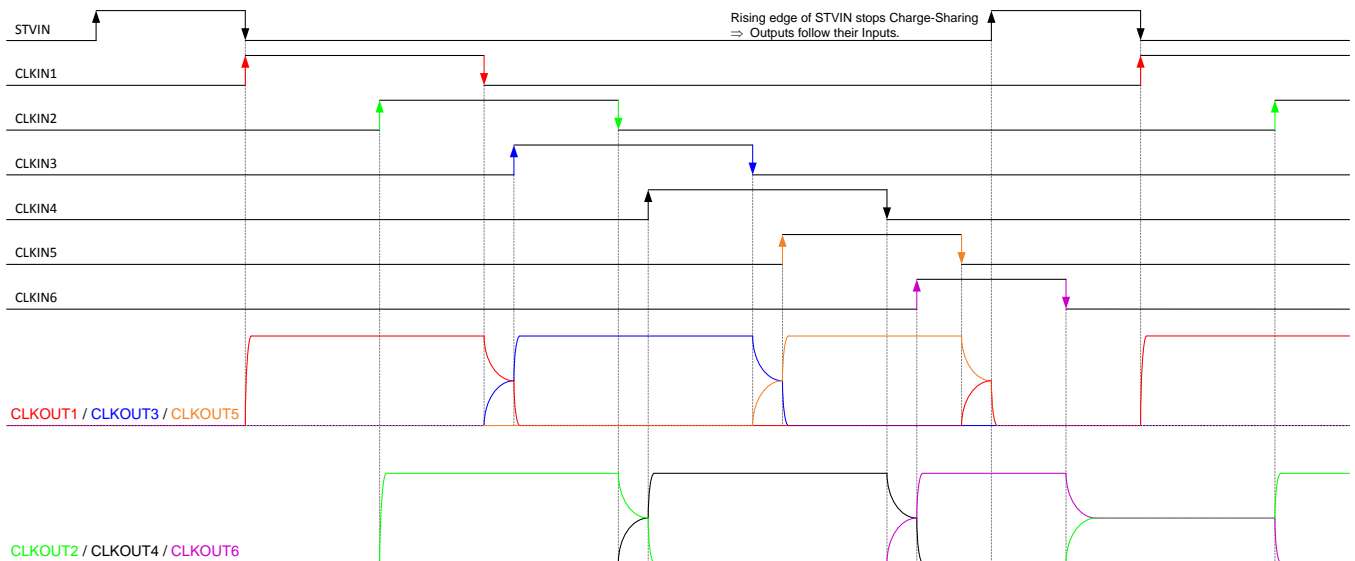
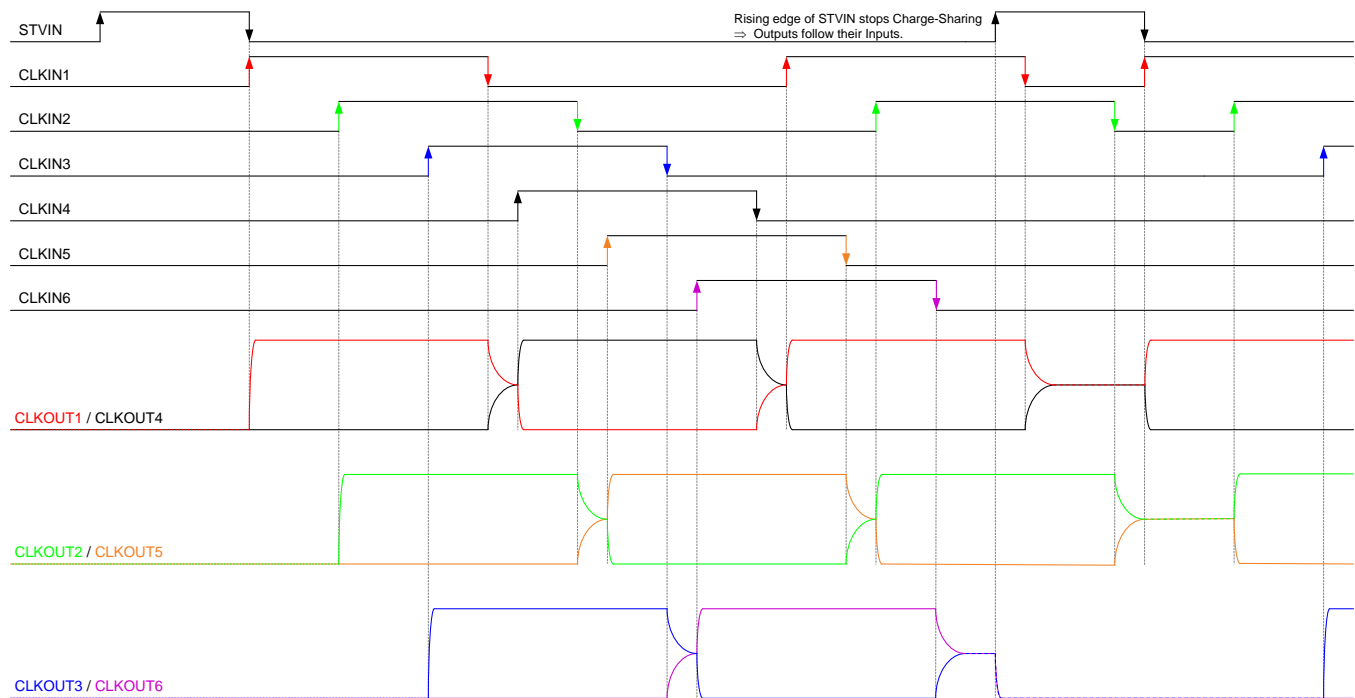

Figure 7. TPS65197B: Charge-Sharing Disabled (CS_SEL < 0.5 V)



- Charge-sharing of CLKOUT1 ↔ CLKOUT3 between CLKIN1↓ CLKIN3↑.
- Charge-sharing of CLKOUT3 ↔ CLKOUT5 between CLKIN3↓ CLKIN5↑.
- Charge-sharing of CLKOUT5 ↔ CLKOUT1 between CLKIN5↓ CLKIN1↑.
- Charge-sharing of CLKOUT2 ↔ CLKOUT4 between CLKIN2↓ CLKIN4↑.
- Charge-sharing of CLKOUT4 ↔ CLKOUT6 between CLKIN4↓ CLKIN6↑.
- Charge-sharing of CLKOUT6 ↔ CLKOUT2 between CLKIN6↓ CLKIN2↑.

Figure 8. TPS65197B: 3-Channel Charge-Sharing (CS_SEL = 1 V...2 V)

Device Functional Modes (continued)

Charge-sharing of CLKOUT1 ↔ CLKOUT4 between CLKIN1↓ CLKIN4↑ and CLKIN4↓ CLKIN1↑.

Charge-Sharing of CLKOUT2 ↔ CLKOUT5 between CLKIN2↓ CLKIN5↑ and CLKIN5↓ CLKIN2↑.

Charge-Sharing of CLKOUT3 ↔ CLKOUT6 between CLKIN3↓ CLKIN6↑ and CLKIN6↓ CLKIN3↑.

Figure 9. TPS65197B: 2-Channel Charge-Sharing (CS_SEL = 2.8 V...6.5 V)

9 Application and Implementation

NOTE

Information in the following applications sections is not part of the TI component specification, and TI does not warrant its accuracy or completeness. TI's customers are responsible for determining suitability of components for their purposes. Customers should validate and test their design implementation to confirm system functionality.

9.1 Application Information

The TPS65197/B is a 8-channel level-shifter with discharge function. It supports no charge-sharing as well as 2-channel and 3-channel charge-sharing.

9.2 Typical Application

Charge-Sharing resistors can be left open when CS is disabled

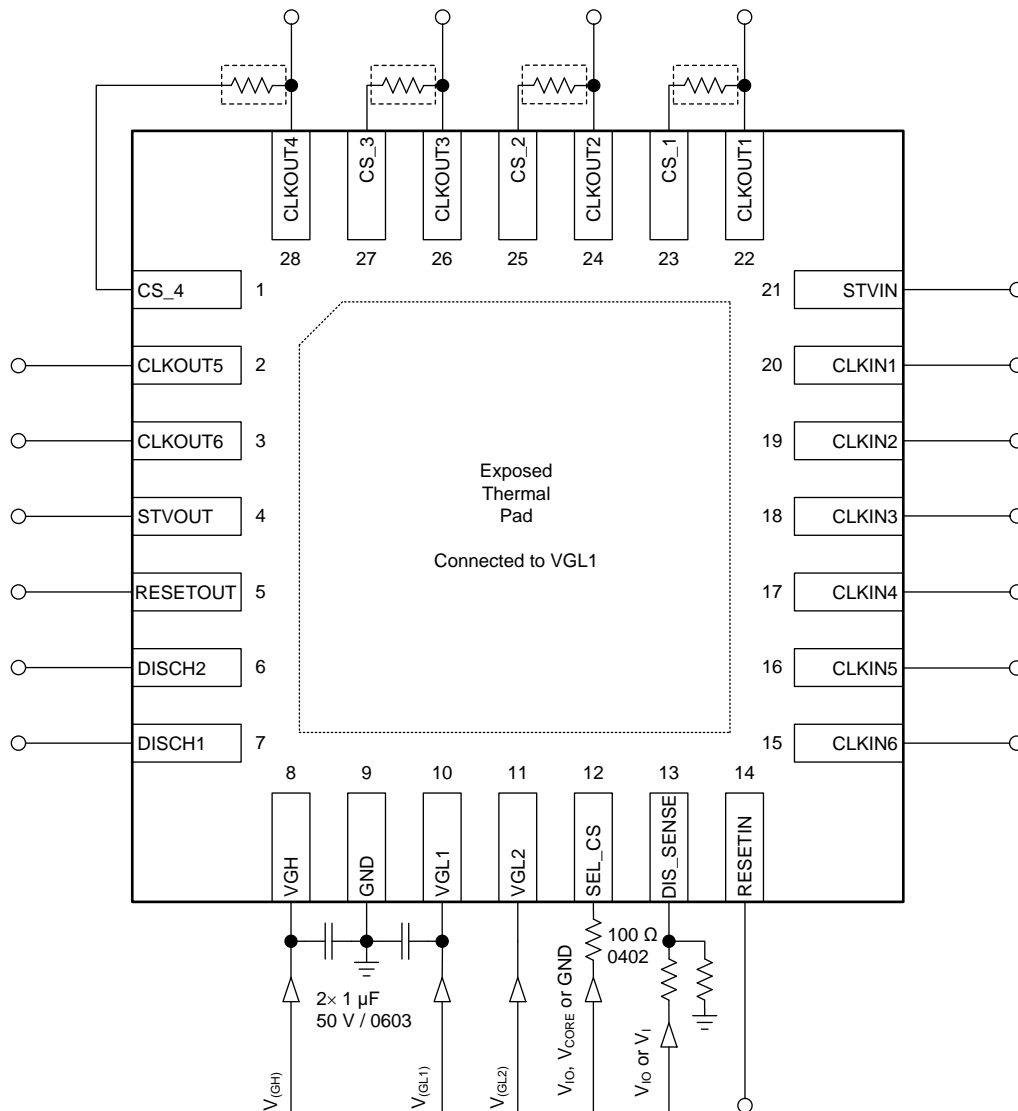

Figure 10. Typical Application Schematic

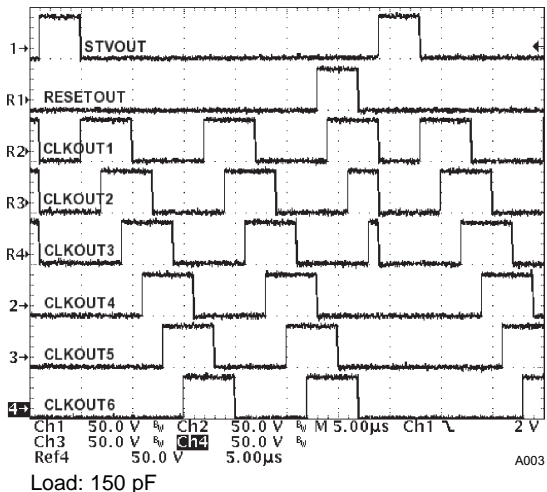

Figure 13. No Charge Sharing Outputs

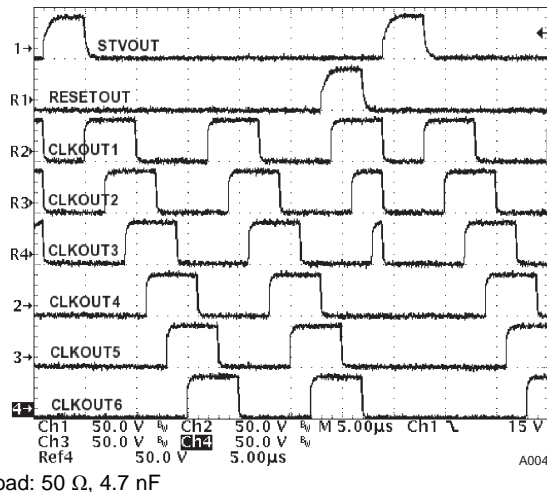

Figure 14. No Charge Sharing Outputs

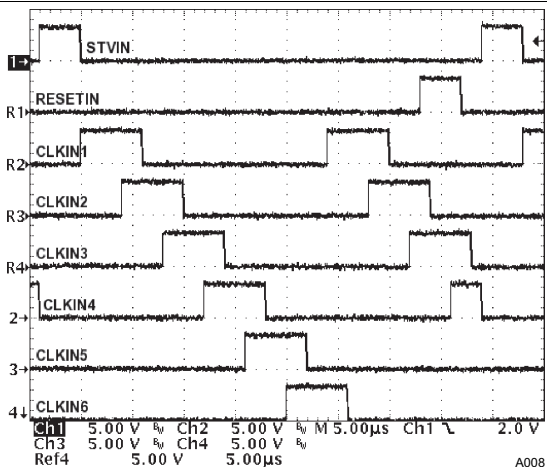

Figure 15. 2-Channel Charge Sharing Input Signals

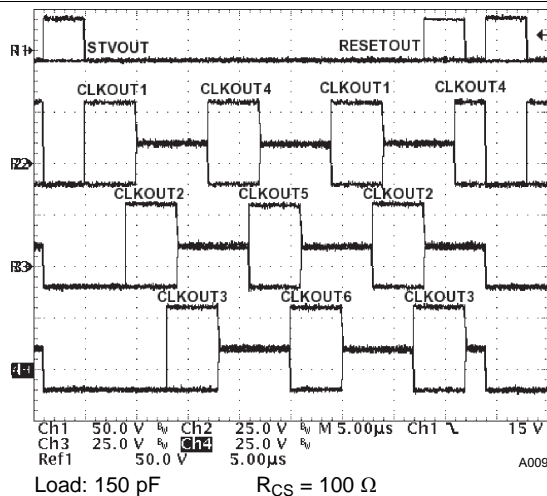

Figure 16. 2-Channel Charge Sharing Outputs

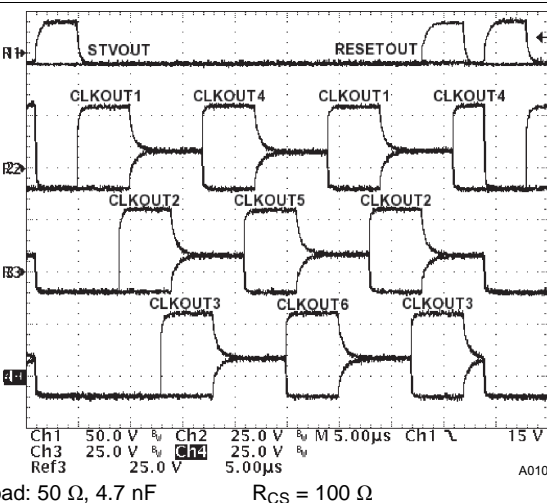

Figure 17. 2-Channel Charge Sharing Outputs

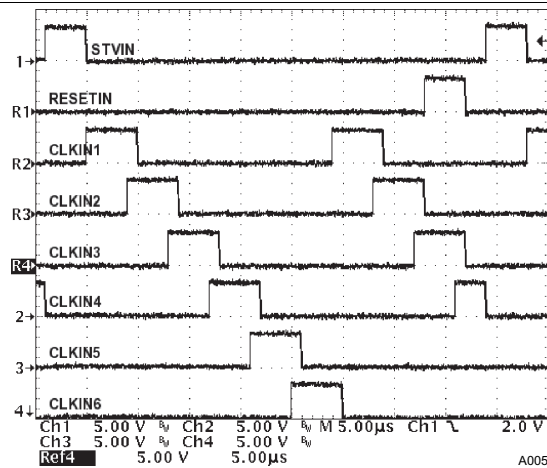
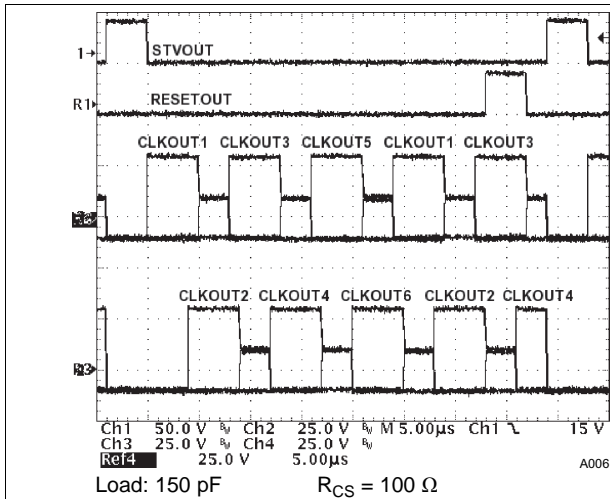
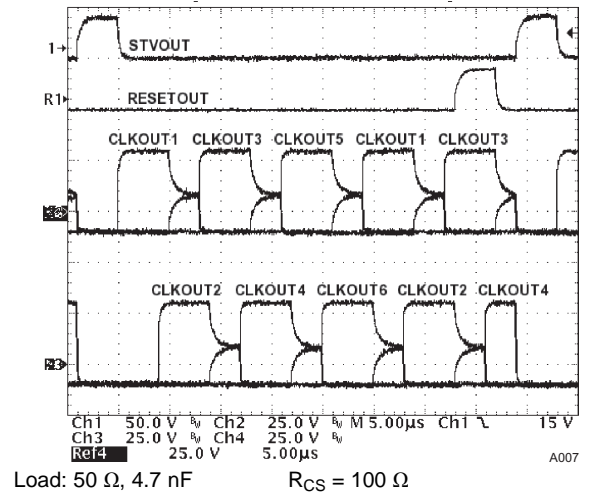

Figure 18. 3-Channel Charge Sharing Input Signals

Figure 19. 3-Channel Charge Sharing Outputs

Figure 20. 3-Channel Charge Sharing Outputs

10 Power Supply Recommendations

The TPS65197/B is designed to operate from an input voltage supply range between 16.5 V and 45 V on the positive supply rail (VGH) and between -20 V and -3 V on the negative supply rails (VGL1, VGL2). A 1- μ F capacitor on VGH and VGL1 should be used to ensure clean output signals.

11 Layout

11.1 Layout Guidelines

Proper PCB layout is essential for achieving the expected performance and a low device temperature. The following points should be considered.

- Place the supply decoupling capacitors as close as possible to device terminals VGH and VGL1.
- Use wide traces to route power from the bias IC to the device to avoid voltage drops. The device is able to sink and source high peak currents up to 1 A. If wide traces are not possible, place additional 1- μ F capacitors of at least 0805 size close to the supply decoupling capacitors.
- The output channel traces should be kept as short as possible to reduce EMI emissions, and not too thin to minimize stray inductances producing voltage overshoots at the panel, because high peak currents up to 1 A can flow.
- The thermal pad must be connected by many vias to a large copper area on a VGL1 potential, to be used as a heat sink. Use a copper area of at least 10 cm². The bigger the copper area, the cooler the device temperature. On a multilayer board, use the copper areas of as many layers as possible to maximize the heat sink.
- Output resistors for clock channels 1 to 6 can be used to reduce EMI emissions and device temperature if necessary. They generate heat and should therefore not be placed close to the device.

11.2 Layout Example

- VIA to VGL1 Plane

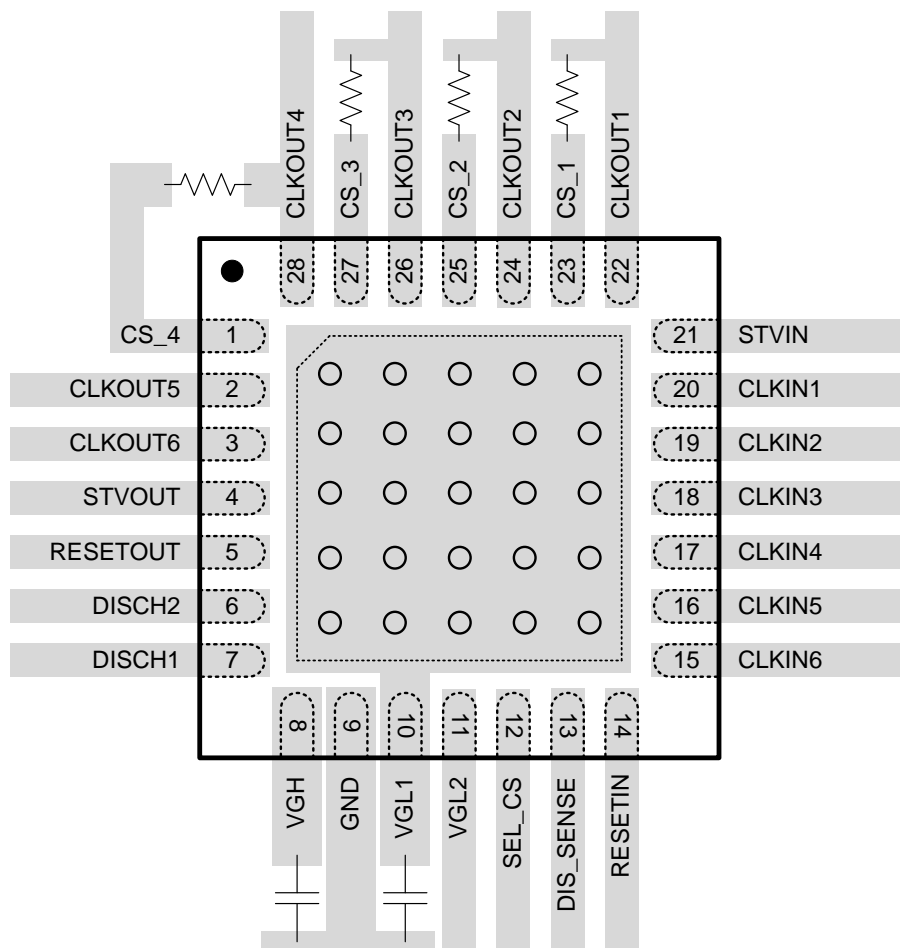

12 Device and Documentation Support

12.1 Documentation Support

12.1.1 Related Documentation

PowerPAD™ Thermally Enhanced Package application report ([SLMA002](#))

PowerPAD™ Made Easy application report ([SLMA004](#))

QFN Layout Guidelines application report ([SLOA122](#))

QFN/SON PCB Attachment application report ([SLUA271](#))

12.2 Related Links

The table below lists quick access links. Categories include technical documents, support and community resources, tools and software, and quick access to order now.

Table 2. Related Links

PARTS	PRODUCT FOLDER	ORDER NOW	TECHNICAL DOCUMENTS	TOOLS & SOFTWARE	SUPPORT & COMMUNITY
TPS65197	Click here	Click here	Click here	Click here	Click here
TPS65197B	Click here	Click here	Click here	Click here	Click here

12.3 Community Resources

The following links connect to TI community resources. Linked contents are provided "AS IS" by the respective contributors. They do not constitute TI specifications and do not necessarily reflect TI's views; see TI's [Terms of Use](#).

TI E2E™ Online Community *TI's Engineer-to-Engineer (E2E) Community*. Created to foster collaboration among engineers. At e2e.ti.com, you can ask questions, share knowledge, explore ideas and help solve problems with fellow engineers.

Design Support *TI's Design Support* Quickly find helpful E2E forums along with design support tools and contact information for technical support.

12.4 Trademarks

E2E is a trademark of Texas Instruments.

All other trademarks are the property of their respective owners.

12.5 Electrostatic Discharge Caution



These devices have limited built-in ESD protection. The leads should be shorted together or the device placed in conductive foam during storage or handling to prevent electrostatic damage to the MOS gates.

12.6 Glossary

[SLYZ022](#) — *TI Glossary*.

This glossary lists and explains terms, acronyms, and definitions.

13 Mechanical, Packaging, and Orderable Information

The following pages include mechanical, packaging, and orderable information. This information is the most current data available for the designated devices. This data is subject to change without notice and revision of this document. For browser-based versions of this data sheet, refer to the left-hand navigation.

PACKAGING INFORMATION

Orderable Device	Status (1)	Package Type	Package Drawing	Pins	Package Qty	Eco Plan (2)	Lead finish/ Ball material (6)	MSL Peak Temp (3)	Op Temp (°C)	Device Marking (4/5)	Samples
TPS65197BRUYR	ACTIVE	WQFN	RUY	28	3000	RoHS & Green	NIPDAU	Level-2-260C-1 YEAR	-40 to 85	TPS 65197B	Samples
TPS65197BRUYT	ACTIVE	WQFN	RUY	28	250	RoHS & Green	NIPDAU	Level-1-260C-UNLIM	-40 to 85	TPS 65197B	Samples
TPS65197RUYR	ACTIVE	WQFN	RUY	28	3000	RoHS & Green	NIPDAU	Level-2-260C-1 YEAR	-40 to 85	TPS 65197A	Samples

(1) The marketing status values are defined as follows:

ACTIVE: Product device recommended for new designs.

LIFEBUY: TI has announced that the device will be discontinued, and a lifetime-buy period is in effect.

NRND: Not recommended for new designs. Device is in production to support existing customers, but TI does not recommend using this part in a new design.

PREVIEW: Device has been announced but is not in production. Samples may or may not be available.

OBsolete: TI has discontinued the production of the device.

(2) **RoHS:** TI defines "RoHS" to mean semiconductor products that are compliant with the current EU RoHS requirements for all 10 RoHS substances, including the requirement that RoHS substance do not exceed 0.1% by weight in homogeneous materials. Where designed to be soldered at high temperatures, "RoHS" products are suitable for use in specified lead-free processes. TI may reference these types of products as "Pb-Free".

RoHS Exempt: TI defines "RoHS Exempt" to mean products that contain lead but are compliant with EU RoHS pursuant to a specific EU RoHS exemption.

Green: TI defines "Green" to mean the content of Chlorine (Cl) and Bromine (Br) based flame retardants meet JS709B low halogen requirements of <=1000ppm threshold. Antimony trioxide based flame retardants must also meet the <=1000ppm threshold requirement.

(3) MSL, Peak Temp. - The Moisture Sensitivity Level rating according to the JEDEC industry standard classifications, and peak solder temperature.

(4) There may be additional marking, which relates to the logo, the lot trace code information, or the environmental category on the device.

(5) Multiple Device Markings will be inside parentheses. Only one Device Marking contained in parentheses and separated by a "~" will appear on a device. If a line is indented then it is a continuation of the previous line and the two combined represent the entire Device Marking for that device.

(6) Lead finish/Ball material - Orderable Devices may have multiple material finish options. Finish options are separated by a vertical ruled line. Lead finish/Ball material values may wrap to two lines if the finish value exceeds the maximum column width.

Important Information and Disclaimer:The information provided on this page represents TI's knowledge and belief as of the date that it is provided. TI bases its knowledge and belief on information provided by third parties, and makes no representation or warranty as to the accuracy of such information. Efforts are underway to better integrate information from third parties. TI has taken and continues to take reasonable steps to provide representative and accurate information but may not have conducted destructive testing or chemical analysis on incoming materials and chemicals. TI and TI suppliers consider certain information to be proprietary, and thus CAS numbers and other limited information may not be available for release.

In no event shall TI's liability arising out of such information exceed the total purchase price of the TI part(s) at issue in this document sold by TI to Customer on an annual basis.

TAPE AND REEL INFORMATION

QUADRANT ASSIGNMENTS FOR PIN 1 ORIENTATION IN TAPE

*All dimensions are nominal

Device	Package Type	Package Drawing	Pins	SPQ	Reel Diameter (mm)	Reel Width W1 (mm)	A0 (mm)	B0 (mm)	K0 (mm)	P1 (mm)	W (mm)	Pin1 Quadrant
TPS65197BRUYR	WQFN	RUY	28	3000	330.0	12.4	4.25	4.25	1.15	8.0	12.0	Q2
TPS65197BRUYT	WQFN	RUY	28	250	180.0	12.4	4.25	4.25	1.15	8.0	12.0	Q2
TPS65197RUYYR	WQFN	RUY	28	3000	330.0	12.4	4.25	4.25	1.15	8.0	12.0	Q2

TAPE AND REEL BOX DIMENSIONS



*All dimensions are nominal

Device	Package Type	Package Drawing	Pins	SPQ	Length (mm)	Width (mm)	Height (mm)
TPS65197BRUYR	WQFN	RUY	28	3000	346.0	346.0	33.0
TPS65197BRUYT	WQFN	RUY	28	250	182.0	182.0	20.0
TPS65197RUYR	WQFN	RUY	28	3000	346.0	346.0	33.0

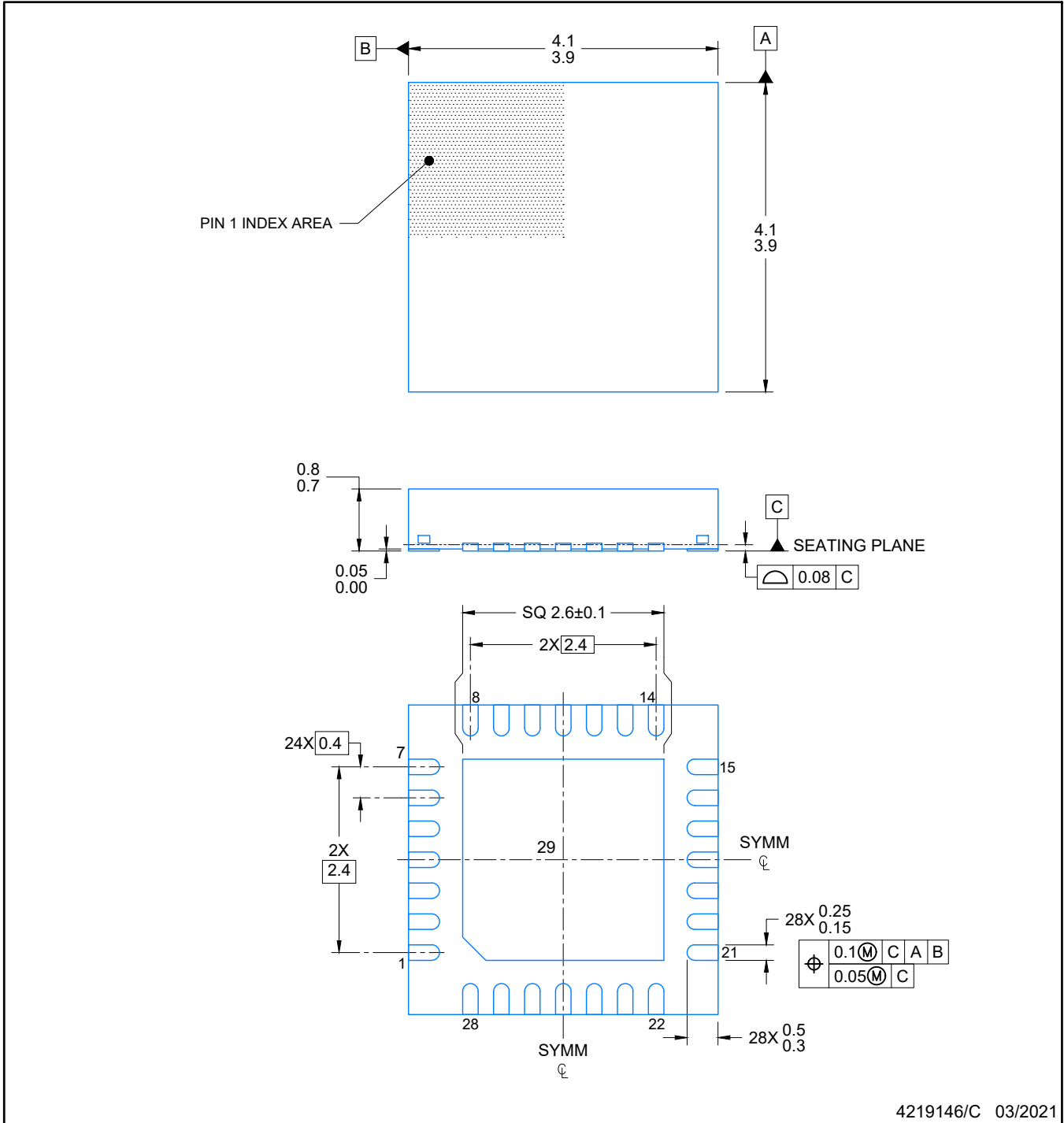

4219146/C 03/2021

NOTES:

1. All linear dimensions are in millimeters. Any dimensions in parenthesis are for reference only. Dimensioning and tolerancing per ASME Y14.5M.
2. This drawing is subject to change without notice.
3. The package thermal pad must be soldered to the printed circuit board for optimal thermal and mechanical performance.

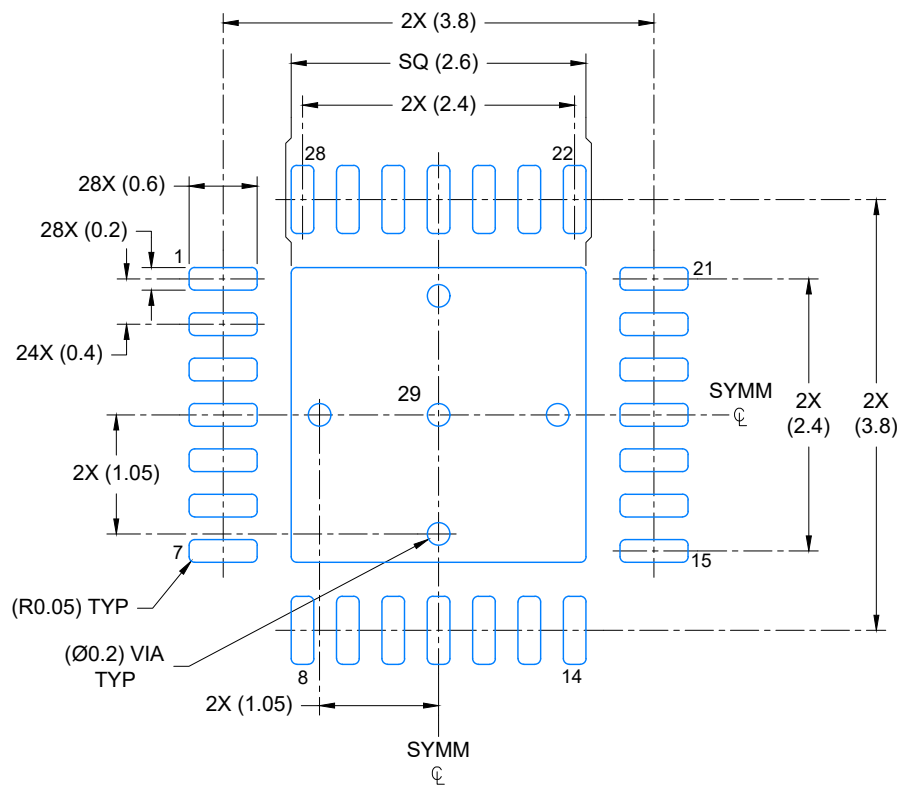

LAND PATTERN EXAMPLE
EXPOSED METAL SHOWN
SCALE: 15X

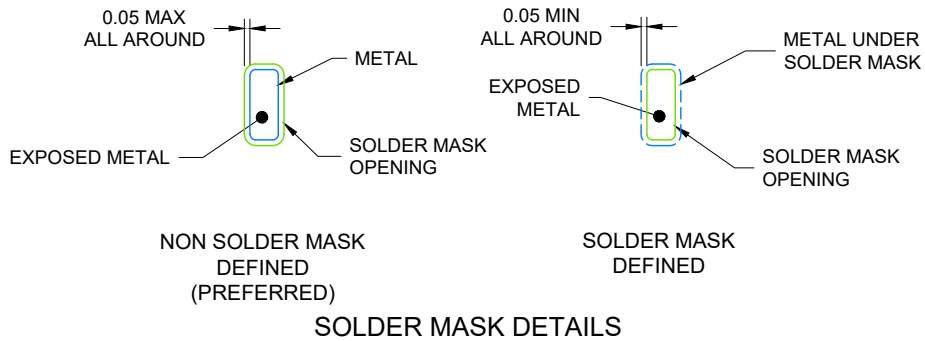

4219146/C 03/2021

NOTES: (continued)

4. This package is designed to be soldered to a thermal pad on the board. For more information, see Texas Instruments literature number SLUA271 (www.ti.com/lit/slua271).
5. Vias are optional depending on application, refer to device data sheet. If any vias are implemented, refer to their locations shown on this view. It is recommended that vias under paste be filled, plugged or tented.

IMPORTANT NOTICE AND DISCLAIMER

TI PROVIDES TECHNICAL AND RELIABILITY DATA (INCLUDING DATA SHEETS), DESIGN RESOURCES (INCLUDING REFERENCE DESIGNS), APPLICATION OR OTHER DESIGN ADVICE, WEB TOOLS, SAFETY INFORMATION, AND OTHER RESOURCES "AS IS" AND WITH ALL FAULTS, AND DISCLAIMS ALL WARRANTIES, EXPRESS AND IMPLIED, INCLUDING WITHOUT LIMITATION ANY IMPLIED WARRANTIES OF MERCHANTABILITY, FITNESS FOR A PARTICULAR PURPOSE OR NON-INFRINGEMENT OF THIRD PARTY INTELLECTUAL PROPERTY RIGHTS.

These resources are intended for skilled developers designing with TI products. You are solely responsible for (1) selecting the appropriate TI products for your application, (2) designing, validating and testing your application, and (3) ensuring your application meets applicable standards, and any other safety, security, regulatory or other requirements.

These resources are subject to change without notice. TI grants you permission to use these resources only for development of an application that uses the TI products described in the resource. Other reproduction and display of these resources is prohibited. No license is granted to any other TI intellectual property right or to any third party intellectual property right. TI disclaims responsibility for, and you will fully indemnify TI and its representatives against, any claims, damages, costs, losses, and liabilities arising out of your use of these resources.

TI's products are provided subject to [TI's Terms of Sale](#) or other applicable terms available either on [ti.com](https://www.ti.com) or provided in conjunction with such TI products. TI's provision of these resources does not expand or otherwise alter TI's applicable warranties or warranty disclaimers for TI products.

TI objects to and rejects any additional or different terms you may have proposed.

Mailing Address: Texas Instruments, Post Office Box 655303, Dallas, Texas 75265
Copyright © 2024, Texas Instruments Incorporated

Looking for pricing, stock, or lifecycle information?

Click below to explore more details on WIN SOURCE:

 [View TPS65197BRUYT](#) on WIN SOURCE

 [Texas Instruments](#) Information

Optimize Your Supply Chain with WIN SOURCE Solutions

-  Global Sourcing Solution
-  Obsolete Management
-  Cost Control Management
-  Shortage Management
-  Alternative Solution
-  Excess Inventory Management