



**THE DATASHEET OF  
TPS65014RGZT**



# TPS65014 Power- and Battery-Management IC for Li-Ion Powered Systems

## 1 Features

- Linear Charger Management for Single Li-Ion or Li-Polymer Cells
- Dual Input Ports for Charging From USB or From Wall Plug, Handles 100-mA and 500-mA USB Requirements
- Charge Current Programmable Through External Resistor
- 1-A, 95% Efficient Step-Down Converter for I/O and Peripheral Components (VMAIN)
- 400-mA, 90% Efficient Step-Down Converter for Processor Core (VCORE)
- 2x 200-mA LDOs for I/O and Peripheral Components, LDO Enable Through Bus
- Serial Interface Compatible With I<sup>2</sup>C, Supports 100-kHz, 400-kHz Operation
- LOW\_PWR Pin to Lower or Disable Processor Core Supply Voltage in Deep-Sleep Mode
- 70- $\mu$ A Quiescent Current
- 1% Reference Voltage
- Thermal-Shutdown Protection

## 2 Applications

- All Single Li-Ion Cell-Operated Products Requiring Multiple Supplies Including:
  - PDAs
  - Cellular and Smart Phones
  - Internet Audio Players
  - Digital Still Cameras
- Digital Radio Players
- Split-Supply DSP and  $\mu$ P Solutions

## 3 Description

The TPS65014 device is an integrated power- and battery-management IC for applications powered by one Li-ion or Li-polymer cell and which require multiple power rails. The TPS65014 provides two highly efficient, step-down converters targeted at providing the core voltage and peripheral I/O rails in a processor-based system. Both step-down converters enter a low-power mode at light load for maximum efficiency across the widest possible range of load currents. The LOW\_PWR pin allows the core converter to lower its output voltage when the application processor goes into deep sleep. The TPS65014 also integrates two 200-mA LDO voltage regulators, which are enabled through the serial interface. Each LDO operates with an input voltage range of 1.8 V to 6.5 V, thus allowing them to be supplied from one of the step-down converters or directly from the battery.

### Device Information<sup>(1)</sup>

PART NUMBER	PACKAGE	BODY SIZE (NOM)
TPS65014	VQFN (48)	7.00 mm x 7.00 mm

(1) For all available packages, see the orderable addendum at the end of the data sheet.

### Functional Block Diagram

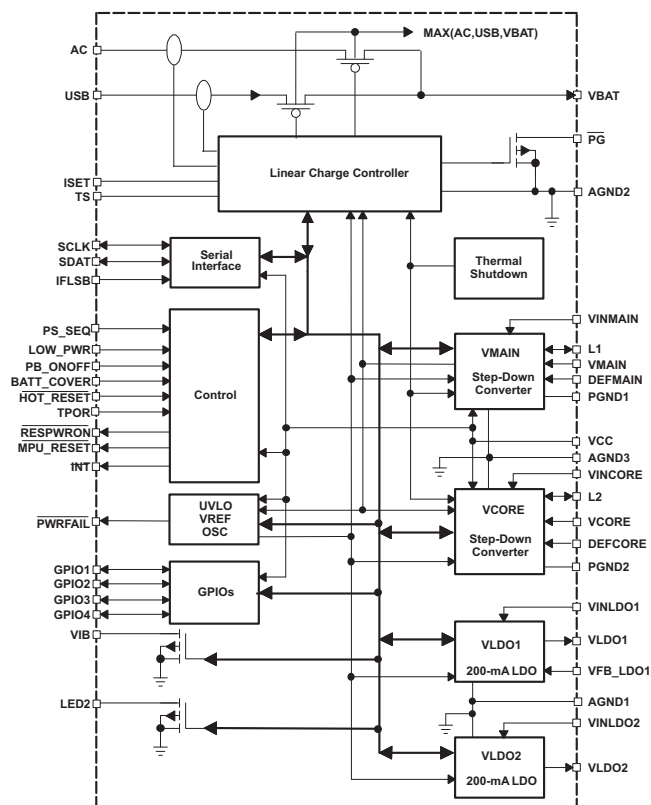

## Table of Contents

<b>1 Features</b> .....	<b>1</b>	7.3 Feature Description.....	<b>20</b>
<b>2 Applications</b> .....	<b>1</b>	7.4 Device Functional Modes.....	<b>37</b>
<b>3 Description</b> .....	<b>1</b>	7.5 Register Maps .....	<b>38</b>
<b>4 Revision History</b> .....	<b>2</b>	<b>8 Application and Implementation</b> .....	<b>51</b>
<b>5 Pin Configuration and Functions</b> .....	<b>3</b>	8.1 Application Information.....	<b>51</b>
<b>6 Specifications</b> .....	<b>5</b>	8.2 Typical Application .....	<b>51</b>
6.1 Absolute Maximum Ratings .....	<b>5</b>	<b>9 Power Supply Recommendations</b> .....	<b>56</b>
6.2 ESD Ratings.....	<b>5</b>	9.1 Battery Charger.....	<b>56</b>
6.3 Recommended Operating Conditions.....	<b>5</b>	9.2 LDO1 Output Voltage Adjustment.....	<b>59</b>
6.4 Thermal Information .....	<b>6</b>	<b>10 Layout</b> .....	<b>59</b>
6.5 Electrical Characteristics.....	<b>6</b>	10.1 Layout Guidelines .....	<b>59</b>
6.6 Electrical Characteristics: Battery Charger .....	<b>9</b>	10.2 Layout Example .....	<b>60</b>
6.7 Dissipation Ratings .....	<b>11</b>	<b>11 Device and Documentation Support</b> .....	<b>61</b>
6.8 Serial Interface Timing Requirements.....	<b>12</b>	11.1 Device Support.....	<b>61</b>
6.9 Switching Characteristics .....	<b>12</b>	11.2 Community Resources.....	<b>61</b>
6.10 Typical Characteristics .....	<b>13</b>	11.3 Trademarks .....	<b>61</b>
<b>7 Detailed Description</b> .....	<b>18</b>	11.4 Electrostatic Discharge Caution.....	<b>61</b>
7.1 Overview .....	<b>18</b>	11.5 Glossary .....	<b>61</b>
7.2 Functional Block Diagram .....	<b>19</b>	<b>12 Mechanical, Packaging, and Orderable Information</b> .....	<b>61</b>

## 4 Revision History

NOTE: Page numbers for previous revisions may differ from page numbers in the current version.

### Changes from Original (December 2004) to Revision A

Page

- Added *ESD Ratings* table, *Feature Description* section, *Device Functional Modes*, *Application and Implementation* section, *Power Supply Recommendations* section, *Layout* section, *Device and Documentation Support* section, and *Mechanical, Packaging, and Orderable Information* section. .... **1**

## 5 Pin Configuration and Functions

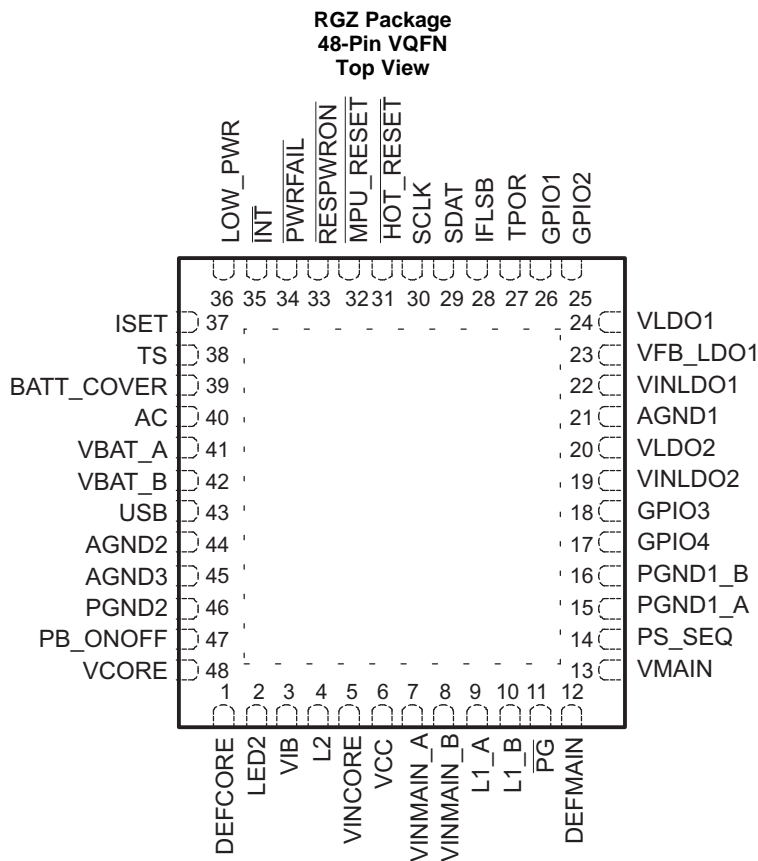

NC – No internal connection

### Pin Functions

PIN		I/O	DESCRIPTION
NAME	NO.		
<b>CHARGER SECTION</b>			
AC	40	I	Charger input voltage from AC adapter. The AC pin can be left open or can be connected to ground if the charger is not used.
AGND2	44	—	Analog ground connection. All analog ground pins are connected internally on the chip.
ISET	37	I	External charge current setting resistor connection for use with AC adapter
PG	11	O	Indicates when a valid power supply is present for the charger (open-drain)
TS	38	I	Battery temperature sense input
USB	43	I	Charger input voltage from USB port. The USB pin can be left open or can be connected to ground if the charger is not used.
VBAT_A	41	I	Sense input for the battery voltage. Connect directly with the battery.
VBAT_B	42	O	Power output of the battery charger. Connect directly with the battery.
Thermal Pad	—	—	Connect the thermal pad to GND
<b>SWITCHING REGULATOR SECTION</b>			
AGND3	45	—	Analog ground connection. All analog ground pins are connected internally on the chip.
L1_A, L1_B	9, 10	—	Switch pin of VMAIN converter. The VMAIN inductor is connected here.
L2	4	—	Switch pin of VCORE converter. The VCORE inductor is connected here.
PGND1_A, PGND1_B	15, 16	—	Power ground for VMAIN converter
PGND2	46	—	Power ground for VCORE converter

**Pin Functions (continued)**

PIN		I/O	DESCRIPTION
NAME	NO.		
<b>SWITCHING REGULATOR SECTION (continued)</b>			
VCC	6	I	Power supply for digital and analog circuitry of MAIN and CORE DC-DC converters. This must be connected to the same voltage supply as VINCORE and VINMAIN. Also supplies serial interface block
VCORE	48	I	VCORE feedback voltage sense input, connect directly to VCORE
VMAIN	13	I	VMAIN feedback voltage sense input, connect directly to VMAIN
VINMAIN_A, VINMAIN_B	7, 8	I	Input voltage for VMAIN step-down converter. This must be connected to the same voltage supply as VINCORE and VCC.
VINCORE	5	I	Input voltage for VCORE step-down converter. This must be connected to the same voltage supply as VINMAIN and VCC.
<b>LDO REGULATOR SECTION</b>			
AGND1	21	—	Analog ground connection. All analog ground pins are connected internally on the chip.
VFB_LDO1	23	I	Feedback input from external resistive divider for LDO1
VINLDO1	22	I	Input voltage for LDO1
VINLDO2	19	I	Input voltage for LDO2
VLDO1	24	O	Output voltage for LDO1
VLDO2	20	O	Output and feedback voltage for LDO2
<b>DRIVER SECTION</b>			
LED2	2	O	LED driver, with blink rate programmable through the serial interface
VIB	3	O	Vibrator driver, enabled through the serial interface
<b>CONTROL AND I2C SECTION</b>			
BATT_COVER	39	I	Indicates if battery cover is in place
DEFV CORE	1	I	Input signal indicating default VCORE voltage, 0 = 1.5 V, 1 = 1.8 V
DEFV MAIN	12	I	Input signal indicating default VMAIN voltage, 0 = 3 V, 1 = 3.3 V
GPIO1	26	I/O	General-purpose open-drain input/output
GPIO2	25	I/O	General-purpose open-drain input/output
GPIO3	18	I/O	General-purpose open-drain input/output
GPIO4	17	I/O	General-purpose open-drain input/output
$\overline{\text{HOT\_RESET}}$	31	I	Push-button reset input used to reboot or wake up processor through the TPS65014
IFLSB	28	I	LSB of serial interface address used to distinguish two devices with the same address
$\overline{\text{INT}}$	35	O	Indicates a charge fault or termination, or if any of the regulator outputs are below the lower tolerance level, active low (open-drain)
LOW_PWR	36	I	Input signal indicating deep sleep mode, VCORE is lowered to predefined value or disabled
$\overline{\text{MPU\_RESET}}$	32	O	Open-drain reset output generated by user activated $\overline{\text{HOT\_RESET}}$
PB_ONOFF	47	I	Push-button enable pin, also used to wake up processor from <i>low power</i> mode
PS_SEQ	14	I	Sets power-up/down sequence of step-down converters
$\overline{\text{PWRFAIL}}$	34	O	Open-drain output. Active low when UVLO comparator indicates low VBAT condition or when shutdown is about to occur due to an overtemperature condition or when the battery cover is removed (BATT_COVER has gone low).
$\overline{\text{RESPWRON}}$	33	O	Open-drain system reset output, generated according to the state of the VMAIN output voltage. If the main output is disabled, $\overline{\text{RESPWRON}}$ is active (in other words, low).
SCLK	30	I	Serial interface clock line
SDAT	29	I/O	Serial interface data/address
TPOR	27	I	Sets the reset delay time at $\overline{\text{RESPWRON}}$ . TPOR = 0: $T_{n(\text{RESPWRON})} = 100 \text{ ms}$ . TPOR = 1: $T_{n(\text{RESPWRON})} = 1 \text{ s}$ .

## 6 Specifications

### 6.1 Absolute Maximum Ratings

over operating free-air temperature range unless otherwise noted<sup>(1)</sup>

	MIN	MAX	UNIT
Input voltage on VAC pin with respect to AGND		20	V
Input voltage range on all other pins except AGND/PGND pins with respect to AGND	-0.3	7	V
Current at AC, VBAT, VINMAIN, L1, PGND1		1800	mA
Peak current at all other pins		1000	mA
Continuous power dissipation		See <a href="#">Dissipation Ratings</a>	
Operating free-air temperature, T <sub>A</sub>	-40	85	°C
Maximum junction temperature, T <sub>J</sub>		125	°C
Storage temperature, T <sub>stg</sub>	-65	150	°C
Lead temperature 1,6 mm (1/16 inch) from case for 10 seconds		260	°C

- (1) Stresses beyond those listed under *Absolute Maximum Ratings* may cause permanent damage to the device. These are stress ratings only, and functional operation of the device at these or any other conditions beyond those indicated under *Recommended Operating Conditions* is not implied. Exposure to absolute-maximum-rated conditions for extended periods may affect device reliability.

### 6.2 ESD Ratings

		VALUE	UNIT
V <sub>(ESD)</sub> Electrostatic discharge	Human-body model (HBM), per ANSI/ESDA/JEDEC JS-001 <sup>(1)(2)</sup>	±1000	V
	Charged-device model (CDM), per JEDEC specification JESD22-C101 <sup>(3)(2)</sup>	±1000	

- (1) JEDEC document JEP155 states that 500-V HBM allows safe manufacturing with a standard ESD control process. Manufacturing with less than 500-V HBM is possible with the necessary precautions. Pins listed as ±1000 V may actually have higher performance.
- (2) At pins VIB,  $\overline{PG}$ , and LED2
- (3) JEDEC document JEP157 states that 250-V CDM allows safe manufacturing with a standard ESD control process. Manufacturing with less than 250-V CDM is possible with the necessary precautions. Pins listed as ±1000 V may actually have higher performance.

### 6.3 Recommended Operating Conditions

		MIN	NOM	MAX	UNIT
V <sub>(AC)</sub>	Supply voltage from AC adapter	4.5		6.5	V
V <sub>(USB)</sub>	Supply voltage from USB	4.4		5.25	V
V <sub>(BAT)</sub>	Voltage at battery	2.5		4.2	V
V <sub>I(MAIN)</sub> , V <sub>I(CORE)</sub> , V <sub>CC</sub>	Input voltage range step-down converters	2.5		6.0	V
V <sub>I(LDO1)</sub> , V <sub>I(LDO2)</sub>	Input voltage range for LDOs	1.8		6.5	V
T <sub>A</sub>	Operating ambient temperature	-40		85	°C
T <sub>J</sub>	Operating junction temperature	-40		125	°C
R <sub>(CC)</sub>	Resistor from V <sub>I(main)</sub> , V <sub>I(core)</sub> to V <sub>CC</sub> used for filtering, C <sub>I(VCC)</sub> = 1 μF		10	100	Ω

## 6.4 Thermal Information

THERMAL METRIC <sup>(1)</sup>		TPS65014	
		RGZ (VQFN)	
		48 PINS	
			UNIT
R <sub>θJA</sub>	Junction-to-ambient thermal resistance	27.0	°C/W
R <sub>θJC(top)</sub>	Junction-to-case (top) thermal resistance	14.3	°C/W
R <sub>θJB</sub>	Junction-to-board thermal resistance	4.6	°C/W
ψ <sub>JT</sub>	Junction-to-top characterization parameter	0.2	°C/W
ψ <sub>JB</sub>	Junction-to-board characterization parameter	4.6	°C/W
R <sub>θJC(bot)</sub>	Junction-to-case (bottom) thermal resistance	1.1	°C/W

(1) For more information about traditional and new thermal metrics, see the *Semiconductor and IC Package Thermal Metrics* application report, [SPRA953](#).

## 6.5 Electrical Characteristics

V<sub>I(MAIN)</sub> = V<sub>I(CORE)</sub> = V<sub>CC</sub> = V<sub>I(LDO1)</sub> = V<sub>I(LDO2)</sub> = 3.6 V, T<sub>A</sub> = –40°C to 85°C, typical values are at T<sub>A</sub> = 25°C battery charger specifications are valid in the range 0°C < T<sub>A</sub> < 85°C unless otherwise noted

PARAMETER		TEST CONDITIONS	MIN	TYP	MAX	UNIT
<b>CONTROL SIGNALS: LOW_PWR, SCLK, SDAT (INPUT)</b>						
V <sub>IH</sub>	High-level input voltage	I <sub>IH</sub> = 20 μA <sup>(1)</sup>	2		V <sub>CC</sub>	V
V <sub>IL</sub>	Low-level input voltage	I <sub>IL</sub> = 10 μA	0		0.8	V
I <sub>IB</sub>	Input bias current			0.01	1	μA
<b>CONTROL SIGNALS: PB_ONOFF, HOT_RESET, BATT_COVER</b>						
V <sub>IH</sub>	High-level input voltage	I <sub>IH</sub> = 20 μA <sup>(1)</sup>	0.8 V <sub>CC</sub>		6	V
V <sub>IL</sub>	Low-level input voltage	I <sub>IL</sub> = 10 μA	0		0.4	V
R <sub>(pb_onoff)</sub>	Pulldown resistor at PB_ONOFF			1000		kΩ
R <sub>(hot_reset)</sub>	Pullup resistor at HOT_RESET, connected to VCC			1000		kΩ
R <sub>(batt_cover)</sub>	Pulldown resistor at BATT_COVER			2000		kΩ
<b>CONTROL SIGNALS: MPU_RESET, PWRFAIL, RESPWRON, INT, SDAT (OUTPUT)</b>						
V <sub>OH</sub>	High-level output voltage				6	V
V <sub>OL</sub>	Low-level output voltage	I <sub>IL</sub> = 10 mA	0		0.3	V
<b>SUPPLY PIN: VCC</b>						
I <sub>(Q)</sub>	Operating quiescent current	V <sub>I</sub> = 3.6 V, current into Main + Core + V <sub>CC</sub>			70	μA
I <sub>(QSD)</sub>	Shutdown supply current	V <sub>I</sub> = 3.6 V, BATT_COVER = GND, Current into Main + Core + V <sub>CC</sub>		15	25	μA

(1) If the input voltage is higher than V<sub>CC</sub>, an additional input current, limited by an internal 10-kΩ resistor, flows.

**Electrical Characteristics (continued)**
 $V_{I(MAIN)} = V_{I(CORE)} = V_{CC} = V_{I(LDO1)} = V_{I(LDO2)} = 3.6\text{ V}$ ,  $T_A = -40^\circ\text{C}$  to  $85^\circ\text{C}$ , typical values are at  $T_A = 25^\circ\text{C}$  battery charger specifications are valid in the range  $0^\circ\text{C} < T_A < 85^\circ\text{C}$  unless otherwise noted

PARAMETER		TEST CONDITIONS	MIN	TYP	MAX	UNIT
<b>VMAIN STEP-DOWN CONVERTER</b>						
$V_I$	Input voltage range		2.5		6	V
$I_O$	Maximum output current		1000			mA
$I_{O(SD)}$	Shutdown supply current	BATT_COVER = GND		0.1	1	$\mu\text{A}$
$r_{DS(on)}$	P-channel MOSFET on-resistance	$V_{I(MAIN)} = V_{GS} = 3.6\text{ V}$		110	210	m $\Omega$
$I_{lkg(p)}$	P-channel leakage current	$V_{(DS)} = 6\text{ V}$			1	$\mu\text{A}$
$r_{DS(on)}$	N-channel MOSFET on-resistance	$V_{I(MAIN)} = V_{GS} = 3.6\text{ V}$		110	200	m $\Omega$
$I_{lkg(N)}$	N-channel leakage current	$V_{(DS)} = 6\text{ V}$			1	$\mu\text{A}$
$I_L$	P-channel current limit	$2.5\text{ V} < V_{I(MAIN)} < 6\text{ V}$	1.4	1.75	2.1	A
$f_S$	Oscillator frequency		1	1.25	1.5	MHz
$V_{O(MAIN)}$	Fixed output voltage	2.5 V	$V_{I(MAIN)} = 2.7\text{ V to }6\text{ V}; I_O = 0\text{ mA}$		0%	3%
			$V_{I(MAIN)} = 2.7\text{ V to }6\text{ V}; 0\text{ mA} \leq I_O \leq 1000\text{ mA}$		3%	3%
		2.75 V	$V_{I(MAIN)} = 2.95\text{ V to }6\text{ V}; I_O = 0\text{ mA}$		0%	3%
			$V_{I(MAIN)} = 2.95\text{ V to }6\text{ V}; 0\text{ mA} \leq I_O \leq 1000\text{ mA}$		3%	3%
		3.0 V	$V_{I(MAIN)} = 3.2\text{ V to }6\text{ V}; I_O = 0\text{ mA}$		0%	3%
			$V_{I(MAIN)} = 3.2\text{ V to }6\text{ V}; 0\text{ mA} \leq I_O \leq 1000\text{ mA}$		3%	3%
		3.3 V	$V_{I(MAIN)} = 3.5\text{ V to }6\text{ V}; I_O = 0\text{ mA}$		0%	3%
			$V_{I(MAIN)} = 3.5\text{ V to }6\text{ V}; 0\text{ mA} \leq I_O \leq 1000\text{ mA}$		3%	3%
Line regulation		$V_{I(MAIN)} = V_{O(MAIN)} + 0.5\text{ V (min. }2.5\text{ V) to }6\text{ V}; I_O = 10\text{ mA}$		0.5		%/V
Load regulation		$I_O = 10\text{ mA to }1000\text{ mA}$		0.12		%/A
$R_{(VMAIN)}$	VMAIN discharge resistance			400		$\Omega$
<b>VCORE STEP-DOWN CONVERTER</b>						
$V_I$	Input voltage range		2.5		6	V
$I_O$	Maximum output current		400			mA
$I_{O(SD)}$	Shutdown supply current	BATT_COVER = GND		0.1	1	$\mu\text{A}$
$r_{DS(on)}$	P-channel MOSFET on-resistance	$V_{I(CORE)} = V_{GS} = 3.6\text{ V}$		275	530	m $\Omega$
$I_{lkg(p)}$	P-channel leakage current	$V_{DS} = 6\text{ V}$		0.1	1	$\mu\text{A}$
$r_{DS(on)}$	N-channel MOSFET on-resistance	$V_{I(CORE)} = V_{GS} = 3.6\text{ V}$		275	500	m $\Omega$
$I_{lkg(N)}$	N-channel leakage current	$V_{DS} = 6\text{ V}$		0.1	1	$\mu\text{A}$
$I_L$	P-channel current limit	$2.5\text{ V} < V_{I(CORE)} < 6\text{ V}$	600	700	900	mA
$f_S$	Oscillator frequency		1	1.25	1.5	MHz

**Electrical Characteristics (continued)**

$V_{I(MAIN)} = V_{I(CORE)} = V_{CC} = V_{I(LDO1)} = V_{I(LDO2)} = 3.6\text{ V}$ ,  $T_A = -40^\circ\text{C}$  to  $85^\circ\text{C}$ , typical values are at  $T_A = 25^\circ\text{C}$  battery charger specifications are valid in the range  $0^\circ\text{C} < T_A < 85^\circ\text{C}$  unless otherwise noted

PARAMETER		TEST CONDITIONS	MIN	TYP	MAX	UNIT	
<b>VCORE STEP-DOWN CONVERTER (continued)</b>							
$V_{O(CORE)}$	Fixed output voltage	0.85 V	$V_{I(CORE)} = 2.5\text{ V to }6\text{ V}; I_O = 0\text{ mA}, C_O = 22\text{ }\mu\text{F}$		0%	3%	
			$V_{I(CORE)} = 2.5\text{ V to }6\text{ V}; 0\text{ mA} \leq I_O \leq 400\text{ mA}, C_O = 22\text{ }\mu\text{F}$		3%	3%	
		1.0 V	$V_{I(CORE)} = 2.5\text{ V to }6\text{ V}; I_O = 0\text{ mA}, C_O = 22\text{ }\mu\text{F}$		0%	3%	
			$V_{I(CORE)} = 2.5\text{ V to }6\text{ V}; 0\text{ mA} \leq I_O \leq 400\text{ mA}, C_O = 22\text{ }\mu\text{F}$		3%	3%	
		1.1 V	$V_{I(CORE)} = 2.5\text{ V to }6\text{ V}; I_O = 0\text{ mA}, C_O = 22\text{ }\mu\text{F}$		0%	3%	
			$V_{I(CORE)} = 2.5\text{ V to }6\text{ V}; 0\text{ mA} \leq I_O \leq 400\text{ mA}, C_O = 22\text{ }\mu\text{F}$		3%	3%	
		1.2 V	$V_{I(CORE)} = 2.5\text{ V to }0\text{ V}; I_O = 0\text{ mA}$		0%	3%	
			$V_{I(CORE)} = 2.5\text{ V to }6\text{ V}; 0\text{ mA} \leq I_O \leq 400\text{ mA}$		3%	3%	
		1.3 V	$V_{I(CORE)} = 2.5\text{ V to }6\text{ V}; I_O = 0\text{ mA}$		0%	3%	
			$V_{I(CORE)} = 2.5\text{ V to }6\text{ V}; 0\text{ mA} \leq I_O \leq 400\text{ mA}$		3%	3%	
		1.4 V	$V_{I(CORE)} = 2.5\text{ V to }6\text{ V}; I_O = 0\text{ mA}$		0%	3%	
			$V_{I(CORE)} = 2.5\text{ V to }6\text{ V}; 0\text{ mA} \leq I_O \leq 400\text{ mA}$		3%	3%	
		1.5 V	$V_{I(CORE)} = 2.5\text{ V to }6\text{ V}; I_O = 0\text{ mA}$		0%	3%	
			$V_{I(CORE)} = 2.5\text{ V to }6\text{ V}; 0\text{ mA} \leq I_O \leq 400\text{ mA}$		3%	3%	
		1.8 V	$V_{I(CORE)} = 2.5\text{ V to }6\text{ V}; I_O = 0\text{ mA}$		0%	3%	
			$V_{I(CORE)} = 2.5\text{ V to }6\text{ V}; 0\text{ mA} \leq I_O \leq 400\text{ mA}$		3%	3%	
Line regulation		$V_{I(CORE)} = V_{O(MAIN)} + 0.5\text{ V}$ (min. 2.5 V) to 6 V, $I_O = 10\text{ mA}$		1		%/V	
Load regulation		$I_O = 10\text{ mA to }400\text{ mA}$		0.002		%/mA	
$R_{(VCORE)}$	VCORE discharge resistance			400		$\Omega$	
<b>VLD01 and VLD02 LOW-DROPOUT REGULATORS</b>							
$V_I$	Input voltage range	LD01		1.8	6.5	V	
		LD02		1.8	$V_{CC}$		
$V_O$	LDO1 output voltage range		0.9	VINLDO1		V	
$V_{ref}$	Reference voltage		485	500	515	mV	
$V_O$	LDO2 output voltage range		1.8		3.3	V	
$I_O$	Maximum output current	Full-power mode		200		mA	
		Low-power mode		30			
$I_{(SC)}$	LDO1 and LDO2 short-circuit current limit	VLD01 = GND, VLD02 = GND			650	mA	
	Dropout voltage	$I_O = 200\text{ mA}, V_{INLDO1,2} = 1.8\text{ V}$			300	mV	
	Total accuracy				$\pm 3\%$		
	Line regulation	VINLDO1,2 = VLD01,2 + 0.5 V (min. 2.5 V) to 6.5 V, $I_O = 10\text{ mA}$		0.75		%/V	
	Load regulation	$I_O = 10\text{ mA to }200\text{ mA}$		0.011		%/mA	
	Regulation time	Load change from 10% to 90%			0.1	ms	
		Low-power mode			0.1		
$I_{(QFP)}$	LDO quiescent current (each LDO)	Full-power mode		16	30	$\mu\text{A}$	
$I_{(QLPM)}$	LDO quiescent current (each LDO)	Low-power mode		12	18	$\mu\text{A}$	
$I_{O(SD)}$	LDO shutdown current (each LDO)			0.1	1	$\mu\text{A}$	
$I_{(kg(FB))}$	Leakage current feedback			0.01	0.1	$\mu\text{A}$	

## 6.6 Electrical Characteristics: Battery Charger

 $V_{O(REG)} + V_{(DO-MAX)} \leq V_{(CHG)} = V_{(AC)} \text{ OR } V_{(USB)}, I_{(TERM)} < I_O \leq 1 \text{ A}, 0^\circ\text{C} < T_A < 85^\circ\text{C}$ 

PARAMETER		TEST CONDITIONS	MIN	TYP	MAX	UNIT
<b>VLDO1 and VLDO2 LOW-DROPOUT REGULATORS (continued)</b>						
$V_{(AC)}$	Input voltage range		4.5		6.5	V
$V_{(USB)}$	Input voltage range		4.35		5.25	V
$I_{CC(VCHG)}$	Supply current	$V_{(CHG)} > V_{(CHG)min}$		1.2	2	mA
$I_{CC(SLP)}$	Sleep current	Sum of currents into VBAT pin, $V_{(CHG)} < V_{(SLP-ENTRY)},$ $0^\circ\text{C} \leq T_J \leq 85^\circ\text{C}$		2	5	$\mu\text{A}$
$I_{CC(STBY)}$	Standby current	Current into USB pin			45	$\mu\text{A}$
		Current into AC pin		200	400	
<b>VOLTAGE REGULATOR</b>						
$V_O$	Output voltage	$V_{(CHG)min} \geq 4.5 \text{ V}$	4.15	4.20	4.25	V
$V_{DO}$	Dropout voltage ( $V_{(AC)} - \text{VBAT}$ )	$V_{O(REG)} + V_{(DO-MAX)} \leq V_{(CHG)},$ $I_{O(OUT)} = 1 \text{ A}$		500	800	mV
	Dropout voltage ( $V_{(USB)} - \text{VBAT}$ )	$V_{O(REG)} + V_{(DO-MAX)} \leq V_{(CHG)},$ $I_{O(OUT)} = 0.5 \text{ A}$		300	500	
	Dropout voltage ( $V_{(USB)} - \text{VBAT}$ )	$V_{O(REG)} + V_{(DO-MAX)} \leq V_{(CHG)},$ $I_{O(OUT)} = 0.1 \text{ A}$		100	150	
<b>CURRENT REGULATION</b>						
$I_{O(AC)}$	Output current range for ac operation <sup>(1)</sup>	$V_{CHG} \geq 4.5 \text{ V}, V_{I(OUT)} > V_{(LOWV)},$ $V_{(AC)} - V_{I(BAT)} > V_{(DO-MAX)}$	100		1000	mA
$V_{(SET)}$	Output current set voltage for ac operation at ISET pin. 100% output current I <sup>2</sup> C register CHGCONFIG<4:3> = 11		2.45	2.50	2.55	V
	75% output current I <sup>2</sup> C register CHGCONFIG<4:3> = 10	$V_{min} \geq 4.5 \text{ V}, V_{I(BAT)} > V_{(LOWV)}, V_{(AC)} - V_{I(BAT)} > V_{(DO-MAX)}$	1.83	1.91	1.99	
	50% output current I <sup>2</sup> C register CHGCONFIG<4:3> = 01		1.23	1.31	1.39	
	32% output current I <sup>2</sup> C register CHGCONFIG<4:3> = 00		0.76	0.81	0.86	
KSET	Output current set factor for ac operation	100 mA < $I_O$ < 1000 mA	310	330	350	
		10 mA < $I_O$ < 100 mA	300	340	380	
$I_{O(USB)}$	Output current range for USB operation	$V_{(CHG)min} \geq 4.35 \text{ V}, V_{I(BAT)} > V_{(LOWV)},$ $V_{(USB)} - V_{I(BAT)} > V_{(DO-MAX)},$ I <sup>2</sup> C register CHGCONFIG<2> = 0	80		100	mA
		$V_{(CHG)min} \geq 4.5 \text{ V}, V_{I(BAT)} > V_{(LOWV)},$ $V_{USB} - V_{I(BAT)} > V_{(DO-MAX)},$ I <sup>2</sup> C register CHGCONFIG<2> = 1	400		500	
$R_{(ISET)}$	Resistor range at ISET pin		825		8250	$\Omega$
<b>PRECHARGE CURRENT REGULATION, SHORT-CIRCUIT CURRENT, AND BATTERY DETECTION CURRENT</b>						
$V_{(LOWV)}$	Precharge to fast-charge transition threshold, voltage on VBAT pin.	$V_{(CHG)} min \geq 4.5 \text{ V}$	2.8	3	3.2	V
$I_{(PRECHG)}$	Precharge current <sup>(2)</sup>	$0 \leq V_{I(OUT)} < V_{(LOWV)}, t < t_{(PRECHG)}$	10		100	mA
$I_{(DETECT)}$	Battery detection current			200		$\mu\text{A}$
$V_{(SET-PRECHG)}$	Voltage at ISET pin	$0 \leq V_{I(OUT)} < V_{(LOWV)}, t < t_{(PRECHG)}$	240	255	270	mV

$$(1) \quad I_{O(AC)} = \frac{KSET \times V_{(SET)}}{R_{(ISET)}}$$

$$(2) \quad I_{(PRECHG)} = \frac{KSET \times V_{(SET\_PRECHG)}}{R_{(ISET)}}$$

**Electrical Characteristics: Battery Charger (continued)**
 $V_{O(REG)} + V_{(DO-MAX)} \leq V_{(CHG)} = V_{(AC)} \text{ or } V_{(USB)}, I_{(TERM)} < I_O \leq 1 \text{ A}, 0^\circ\text{C} < T_A < 85^\circ\text{C}$ 

PARAMETER		TEST CONDITIONS	MIN	TYP	MAX	UNIT
<b>CHARGE TAPER AND TERMINATION DETECTION</b>						
$I_{(TAPER)}$	Taper current detect range <sup>(3)</sup>	$V_{I(OUT)} > V_{(RCH)}, t < t_{(TAPER)}$	10		100	mA
$V_{(SET\_TAPER)}$	Voltage at ISET pin for charge TAPER detection	$V_{I(OUT)} > V_{(RCH)}, t < t_{(TAPER)}$	235	250	265	mV
$V_{(SET\_TERM)}$	Voltage at ISET pin for charger termination detection <sup>(4)</sup>	$V_{I(OUT)} > V_{(RCH)}$	11	18	25	mV
<b>TEMPERATURE COMPARATOR</b>						
$V_{(LTF)}$	Low (cold) temperature threshold		2.475	2.50	2.525	V
$V_{(HTF)}$	High (hot) temperature threshold		0.485	0.5	0.515	V
$I_{(TS)}$	TS current source		95	102	110	μA
<b>BATTERY RECHARGE THRESHOLD</b>						
$V_{(RCH)}$	Recharge threshold	$V_{(CHG)min} \geq 4.5 \text{ V}$	$V_{O(REG)} - 0.115$	$V_{O(REG)} - 0.1$	$V_{O(REG)} - 0.085$	V
<b>SLEEP AND STANDBY</b>						
$V_{(SLP\_ENTRY)}$	Sleep-mode entry threshold, $\overline{PG}$ output = high	$2.3 \text{ V} \leq V_{I(OUT)} \leq V_{O(REG)}$			$V_{(CHG)} \leq V_{I(OUT)} + 150 \text{ mV}$	V
$V_{(SLP\_EXIT)}$	Sleep-mode exit threshold, $\overline{PG}$ output = low	$2.3 \text{ V} \leq V_{I(OUT)} \leq V_{O(REG)}$		$V_{(CHG)} \geq V_{I(OUT)} + 250 \text{ mV}$		V
<b>CHARGER POWER-ON-RESET, UVLO, AND <math>V_{(IN)}</math> RAMP RATE</b>						
$V_{(CHGUVLO)}$	Charger undervoltage lockout	$V_{(CHG)}$ decreasing	2.27	2.5	2.75	V
	Hysteresis			27		mV
$V_{(CHGOVLO)}$	Charger overvoltage lockout		6.5			V
<b>CHARGER OVERTEMPERATURE SUSPEND</b>						
$T_{(suspend)}$	Temperature at which charger suspends operation			145		°C
$T_{(hyst)}$	Hysteresis of suspend threshold			20		°C

$$(3) \quad I_{(TAPER)} = \frac{K_{SET} \times V_{(SET\_TAPER)}}{R_{(ISET)}}$$

$$(4) \quad I_{(TERM)} = \frac{K_{SET} \times V_{(SET\_TERM)}}{R_{(ISET)}}$$

## Electrical Characteristics: Battery Charger (continued)

$$V_{O(REG)} + V_{(DO-MAX)} \leq V_{(CHG)} = V_{(AC)} \text{ or } V_{(USB)}, I_{(TERM)} < I_O \leq 1 \text{ A}, 0^\circ\text{C} < T_A < 85^\circ\text{C}$$

PARAMETER		TEST CONDITIONS	MIN	TYP	MAX	UNIT
<b>LOGIC SIGNALS DEFMAIN, DEFCORE, PS_SEQ, IFLSB</b>						
V <sub>IH</sub>	High-level input voltage	I <sub>IH</sub> = 20 μA	V <sub>CC</sub> – 0.5		V <sub>CC</sub>	V
V <sub>IL</sub>	Low-level input voltage	I <sub>IL</sub> = 10 μA	0		0.4	V
I <sub>IB</sub>	Input bias current			0.01	1	μA
<b>LOGIC SIGNALS GPIO1-4</b>						
V <sub>OL</sub>	Low-level output voltage	I <sub>OL</sub> = 1 mA, configured as an open-drain output			0.3	V
V <sub>OH</sub>	High-level output voltage	Configured as an open-drain output			6	V
V <sub>IL</sub>	Low-level input voltage		0		0.8	V
V <sub>IH</sub>	High-level input voltage		2		V <sub>CC</sub> <sup>(5)</sup>	V
I <sub>I</sub>	Input leakage current				1	μA
r <sub>DS(on)</sub>	Internal NMOS	V <sub>OL</sub> = 0.3 V		150		Ω
<b>LOGIC SIGNALS PG, LED2</b>						
V <sub>OL</sub>	Low-level output voltage	I <sub>OL</sub> = 20 mA			0.5	V
V <sub>OH</sub>	High-level output voltage				6	V
V <sub>(PG)</sub>	$\overline{\text{PG}}$ threshold voltage USB and AC				V <sub>(BAT)</sub> + xx mV	V
<b>VIBRATOR DRIVER VIB</b>						
V <sub>OL</sub>	Low-level output voltage	I <sub>OL</sub> = 100 mA		0.3	0.5	V
V <sub>OH</sub>	High-level output voltage				6	V
<b>THERMAL SHUTDOWN</b>						
T <sub>(SD)</sub>	Thermal shutdown	Increasing junction temperature		160		°C
<b>UNDERVOLTAGE LOCKOUT</b>						
V <sub>(UVLO)</sub>	Undervoltage lockout threshold. The default value for UVLO is 2.75 V	V <sub>(UVLO)</sub> 2.5 V	Filter resistor = 10R in series with V <sub>CC</sub> , V <sub>CC</sub> decreasing	-3%	3%	
		V <sub>(UVLO)</sub> 2.75 V		-3%	3%	
		V <sub>(UVLO)</sub> 3.0 V		-3%	3%	
		V <sub>(UVLO)</sub> 3.25 V		-3%	3%	
V <sub>(UVLO_HYST)</sub>	UVLO comparator hysteresis	V <sub>CC</sub> rising	350	400	450	mV
<b>POWER GOOD</b>						
	Decreasing rail voltage	V <sub>MAIN</sub> , V <sub>CORE</sub> , VLDO1, VLDO2 decreasing	-12%	-10%	-8%	
	Increasing rail voltage	V <sub>MAIN</sub> , V <sub>CORE</sub> , VLDO1, VLDO2 increasing	-7%	-5%	-3%	

(5) If the input voltage is higher than V<sub>CC</sub> an additional current flows, limited by an internal 10-kΩ resistor.

## 6.7 Dissipation Ratings

See <sup>(1)</sup>

AMBIENT TEMPERATURE	MAX POWER DISSIPATION FOR T <sub>j</sub> = 125°C <sup>(2)</sup>	DERATING FACTOR ABOVE T <sub>A</sub> = 55°C
25°C	3 W	30 mW/°C
55°C	2.1 W	

- (1) The TPS65014 is housed in a 48-pin QFN package with exposed leadframe on the underside. This 7-mm x 7-mm package exhibits a thermal impedance (junction-to-ambient) of 33 K/W when mounted on a JEDEC high-k board.
- (2) Consideration needs to be given to the maximum charge current when the assembled application board exhibits a thermal impedance which differs significantly from the JEDEC high-k board.

## 6.8 Serial Interface Timing Requirements

	MIN	MAX	UNIT
Clock frequency, $f_{MAX}$		400	kHz
Clock high time, $t_{wH(HIGH)}$	600		ns
Clock low time, $t_{wL(LOW)}$	1300		ns
DATA and CLK rise time, $t_R$		300	ns
DATA and CLK fall time, $t_F$		300	ns
Hold time (repeated) START condition (after this period the first clock pulse is generated), $t_{h(STA)}$	600		ns
Setup time for repeated START condition, $t_{h(DATA)}$	600		ns
Data input hold time, $t_{h(DATA)}$	0		ns
Data input setup time, $t_{su(DATA)}$	100		ns
STOP condition setup time, $t_{su(STO)}$	600		ns
Bus free time, $t_{(BUF)}$	1300		ns

## 6.9 Switching Characteristics

over operating free-air temperature range (unless otherwise noted)

PARAMETER	TEST CONDITIONS	MIN	TYP	MAX	UNIT	
<b>CONTROL SIGNALS: PB_ONOFF, HOT_RESET, BATT_COVER</b>						
$t_{(glitch)}$	Deglitch time at all 3 pins	38	56	77	ms	
$t_{(batt\_cover)}$	Delay after $t_{(glitch)}$ ( $\overline{PWRFAIL}$ goes low) before supplies are disabled when BATT_COVER goes low.	1.68	2.4	3.2	ms	
<b>CONTROL SIGNALS: MPU_RESET, PWRFAIL, RESPWRON, INT, SDAT (OUTPUT)</b>						
$t_{d(mpu\_nreset)}$	Duration of low pulse at MPU_RESET	100			$\mu$ s	
$t_{d(nrespwron)}$	Duration of low pulse at RESPWRON after VMAIN is in regulation	TPOR = 0	80	100	120	ms
		TPOR = 1	800	1000	1200	
$t_{d(uvlo)}$	Time between UVLO going active ( $\overline{PWRFAIL}$ going low) and supplies being disabled	1.68	2.4	3.2	ms	
$t_{d(overtemp)}$	Time between chip overtemperature condition being recognized ( $\overline{PWRFAIL}$ going low) and supplies being disabled	1.68	2.4	3.2	ms	
<b>PRECHARGE CURRENT REGULATION, SHORT-CIRCUIT CURRENT, AND BATTERY DETECTION CURRENT</b>						
Deglitch time	$V_{(CHG)}$ min $\geq$ 4.5 V, $V_{I(OUT)}$ decreasing below threshold; 100-ns fall time, 10-mV overdrive	8.8	23	60	ms	
<b>CHARGE TAPER AND TERMINATION DETECTION</b>						
Deglitch time for $I_{(TAPER)}$	$V_{(CHG)}$ min $\geq$ 4.5V, charging current increasing or decreasing above and below; 100-ns fall time, 10-mV overdrive	8.8	23	60	ms	
Deglitch time for $I_{(TERM)}$	$V_{(CHG)}$ min $\geq$ 4.5 V, charging current decreasing below; 100-ns fall time, 10-mV overdrive	8.8	23	60	ms	
<b>TEMPERATURE COMPARATOR</b>						
Deglitch time for temperature fault		8.8	23	60	ms	
<b>BATTERY RECHARGE THRESHOLD</b>						
Deglitch time	$V_{(CHG)}$ min $\geq$ 4.5 V, $V_{I(OUT)}$ decreasing below threshold; 100-ns fall time, 10-mV overdrive	8.8	23	60	ms	

## Switching Characteristics (continued)

over operating free-air temperature range (unless otherwise noted)

PARAMETER		TEST CONDITIONS	MIN	TYP	MAX	UNIT
<b>TIMERS</b>						
$t_{(PRECHG)}$	Precharge timer	$V_{(CHG)min} \geq 4.5\text{ V}$	1500	1800	2160	s
$t_{(TAPER)}$	Taper timer	$V_{(CHG)min} \geq 4.5\text{ V}$	1500	1800	2160	s
$t_{(CHG)}$	Charge timer	$V_{(CHG)min} \geq 4.5\text{ V}$	15000	18000	21600	s
<b>SLEEP AND STANDBY</b>						
	Deglitch time for sleep mode entry and exit	AC or USB decreasing below threshold; 100-ns fall time, 10-mV overdrive	8.8	23	60	ms
$t_{(USB\_DEL)}$	Delay between valid USB voltage being applied and start of charging process from USB			5		ms

## 6.10 Typical Characteristics

**Table 1. Table of Graphs**

		FIGURE
Efficiency	vs Output current	<a href="#">Figure 1</a> , <a href="#">Figure 2</a>
Quiescent current	vs Input voltage	<a href="#">Figure 3</a>
Switching frequency	vs Temperature	<a href="#">Figure 4</a>
LDO1 Output voltage	vs Output current	<a href="#">Figure 5</a> - <a href="#">Figure 8</a>
LDO2 Output voltage	vs Output current	<a href="#">Figure 9</a>
Line transient response (main)		<a href="#">Figure 9</a>
Line transient response (core)		<a href="#">Figure 10</a>
Line transient response (LDO1)		<a href="#">Figure 11</a>
Line transient response (LDO2)		<a href="#">Figure 12</a>
Load transient response (main)		<a href="#">Figure 13</a>
Load transient response (core)		<a href="#">Figure 14</a>
Load transient response (LDO1)		<a href="#">Figure 15</a>
Load transient response (LDO2)		<a href="#">Figure 16</a>
Output voltage ripple (PFM)		<a href="#">Figure 17</a>
Output voltage ripple (PWM)		<a href="#">Figure 18</a>
Start-up timing		<a href="#">Figure 19</a>
Dropout voltage	vs Output current	<a href="#">Figure 20</a> , <a href="#">Figure 21</a>
PSRR (LDO1 and LDO2)	vs Frequency	<a href="#">Figure 22</a>

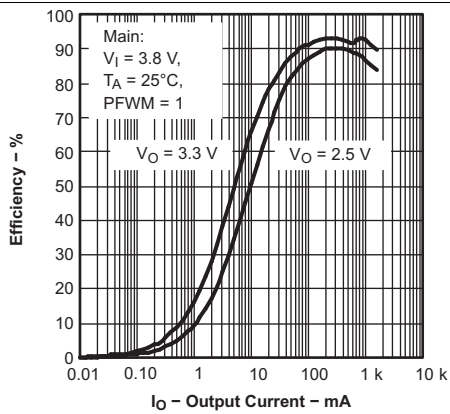

Figure 1. Efficiency vs Output Current

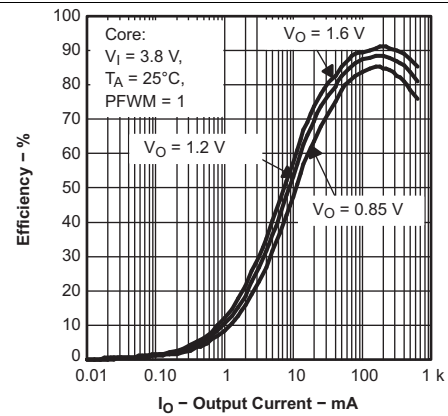

Figure 2. Efficiency vs Output Current

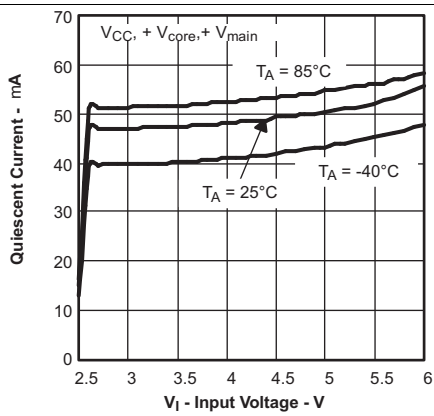

Figure 3. Quiescent Current vs Input Voltage

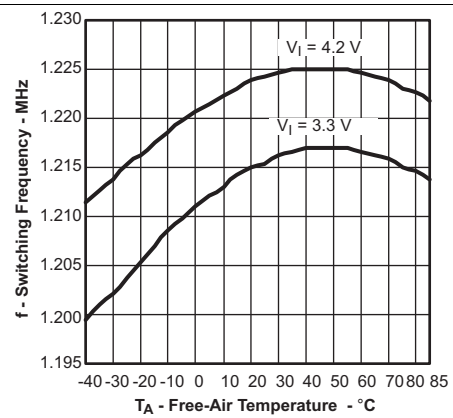

Figure 4. Switching Frequency vs Temperature

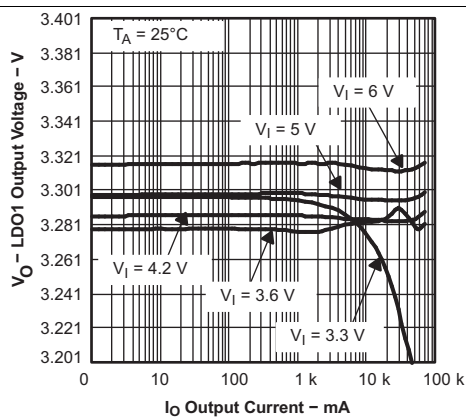

Figure 5. LD01 Output Voltage vs Output Current

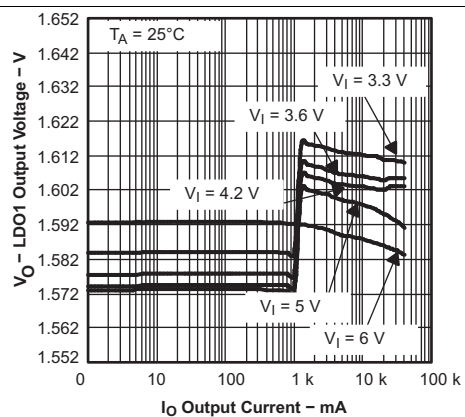

Figure 6. LD01 Output Voltage vs Output Current

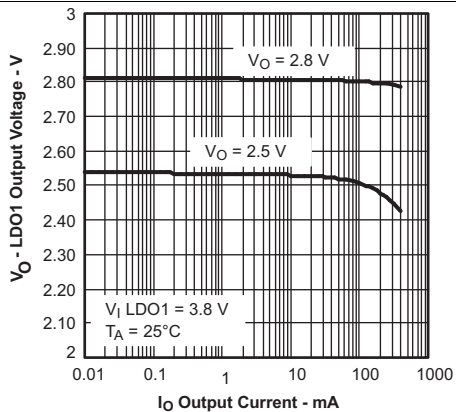

Figure 7. LDO1 Output Voltage vs Output Current

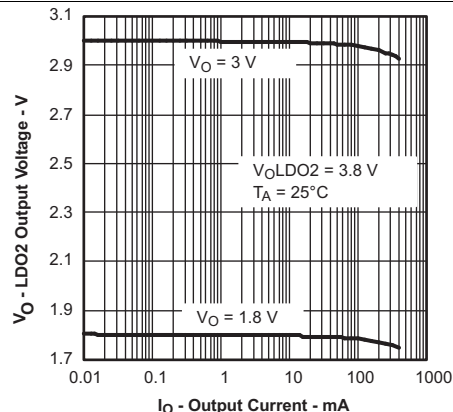

Figure 8. LDO2 Output Voltage vs Output Current

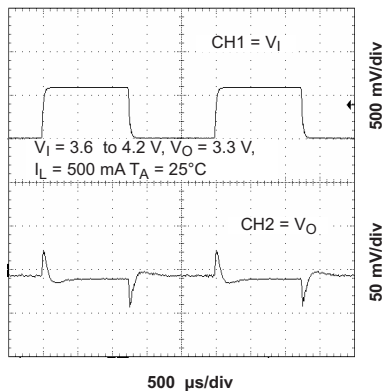

Figure 9. Line Transient Response (Main)

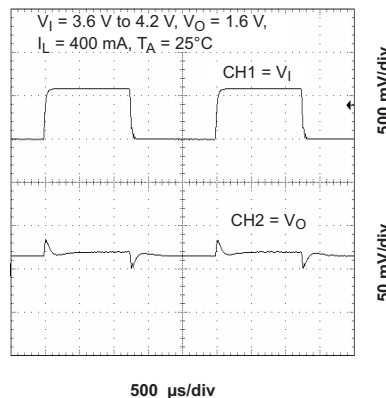

Figure 10. Line Transient Response (Core)

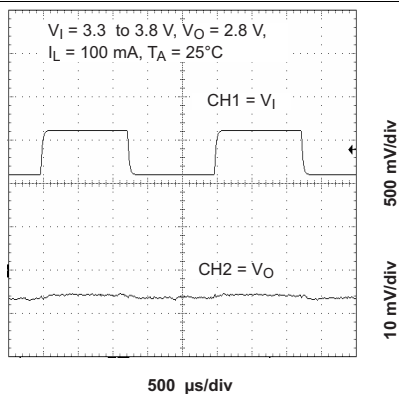

Figure 11. Line Transient Response (LDO1)

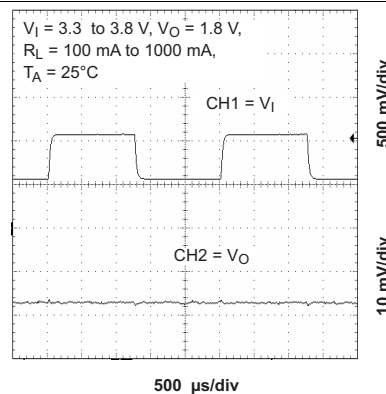
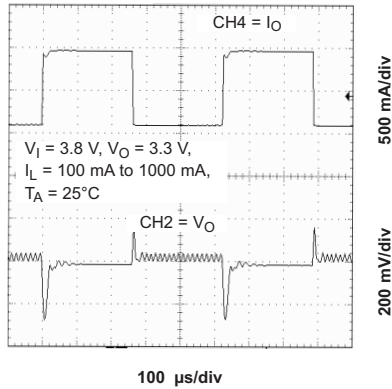
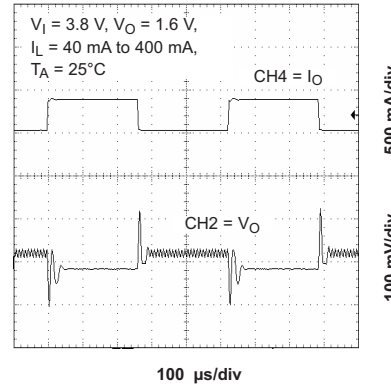
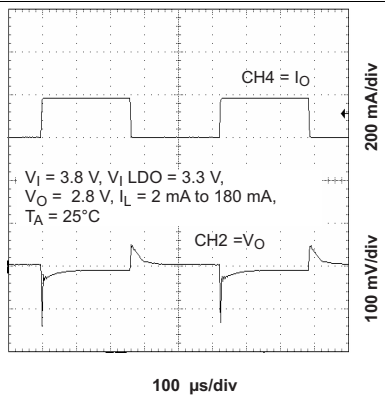
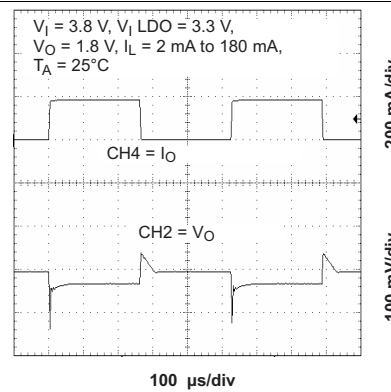
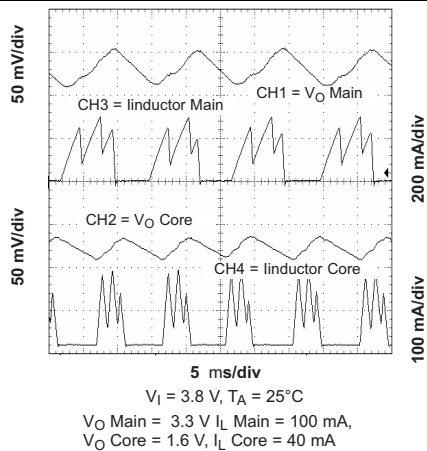
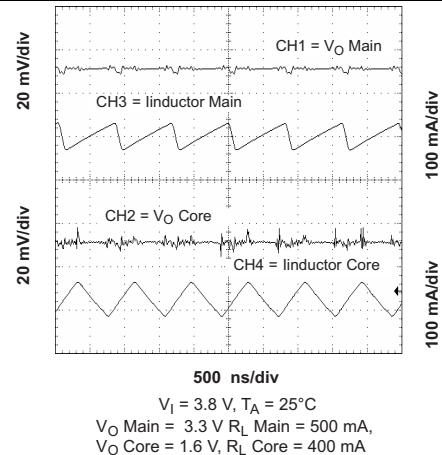
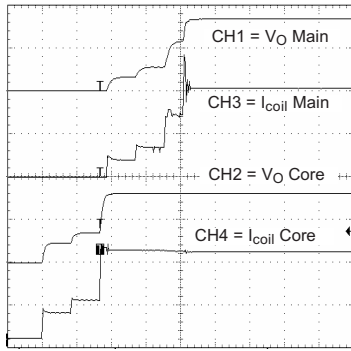

Figure 12. Line Transient Response (LDO2)

**Figure 13. Load Transient Response (Main)**

**Figure 14. Load Transient Response (Core)**

**Figure 15. Load Transient Response (LDO1)**

**Figure 16. Load Transient Response (LDO2)**

**Figure 17. Output Ripple (PFM)**

**Figure 18. Output Ripple (PWM)**



500 ms/div

$V_I = 3.8\text{ V}$ ,  $V_O\text{ Main} = 3.3\text{ V}$ ,  
 $R_L\text{ Main} = 1\text{ A}$ ,  $V_O\text{ Core} = 1.6\text{ V}$ ,  
 $R_L\text{ Core} = 400\text{ mA}$ ,  $T_A = 25^\circ\text{C}$

Figure 19. Start-Up Timing

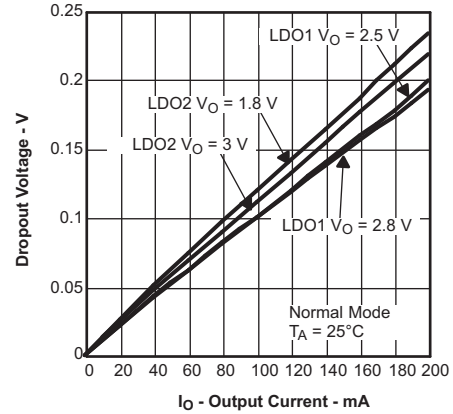

Figure 20. Dropout Voltage vs Output Current

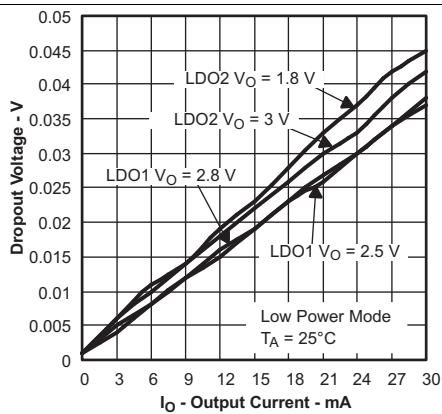

Figure 21. Dropout Voltage vs Output Current

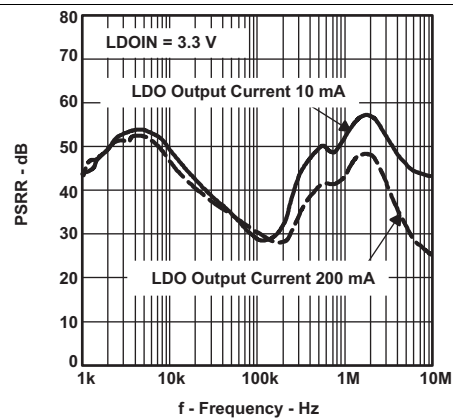

Figure 22. PSRR (LDO1, LDO2) vs Frequency

## 7 Detailed Description

### 7.1 Overview

The TPS65014 has a highly integrated and flexible Li-Ion linear charger and system power management. It offers an integrated USB port and AC-adaptor supply management with autonomous power-source selection, power FET and current sensor, high accuracy current and voltage regulation, charge status, and charge termination.

The TPS65014 charger automatically selects the USB port or the AC adapter as the power source for the system. In the USB configuration, the host can increase the charge current from the default value of maximum 100 mA to 500 mA through the interface. In the AC adapter configuration, an external resistor sets the maximum value of charge current.

The battery is charged in three phases: conditioning, constant current, and constant voltage. Charge is normally terminated based on minimum current. An internal charge timer provides a safety backup for charge termination. The TPS65014 automatically restarts the charge if the battery voltage falls below an internal threshold. The charger automatically enters sleep mode when both supplies are removed.

The serial interface can be used for dynamic voltage scaling, for collecting information on and controlling the battery charger status, for optionally controlling 2-LED driver outputs, a vibrator driver, masking interrupts, or for disabling, enabling, and setting the LDO output voltages. The interface is compatible with the fast- and standard-mode I<sup>2</sup>C specification, thus allowing transfers up to 400 kHz.

## 7.2 Functional Block Diagram

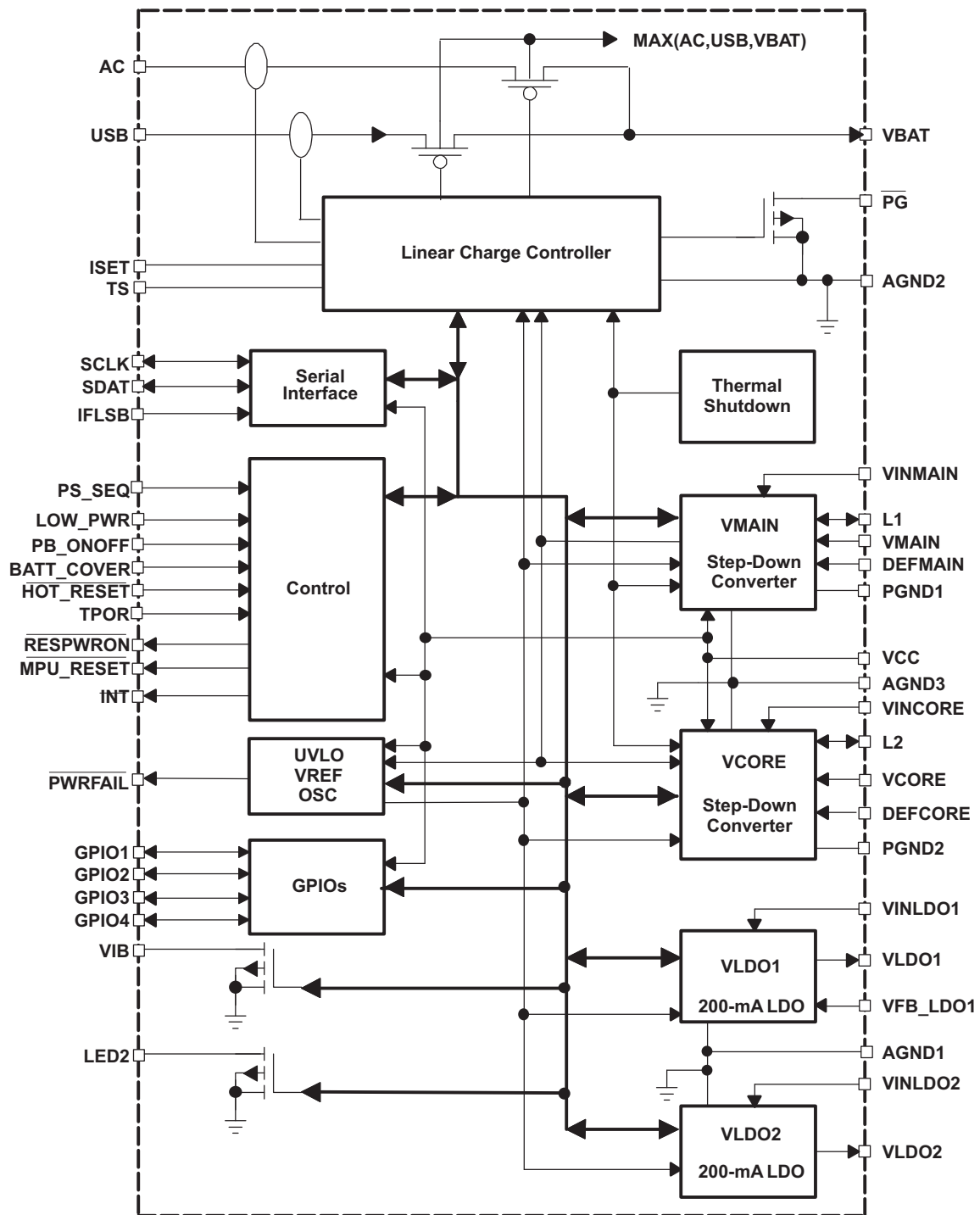

## 7.3 Feature Description

### 7.3.1 Step-Down Converters, VMAIN and VCORE

The TPS65014 incorporates two synchronous step-down converters operating typically at 1.25-MHz fixed frequency pulse width modulation (PWM) at moderate to heavy load currents. At light load currents, the converters automatically enter power-save mode and operate with pulse frequency modulation (PFM). The main converter is capable of delivering 1-A output current and the core converter is capable of delivering 400 mA.

The converter output voltages are programmed through the VDCDC1 and VDCDC2 registers in the serial interface. The main converter defaults to 3-V or 3.3-V output voltage depending on the DEFMAIN configuration pin, if DEFMAIN is tied to ground, the default is 3 V; if it is tied to  $V_{CC}$ , the default is 3.3 V. The core converter defaults to either 1.5 V or 1.8 V, depending on whether the DEFCORE configuration pin is tied to GND or to  $V_{CC}$ , respectively. Both the main and core output voltages can subsequently be reprogrammed after start-up through the serial interface. In addition, the LOW\_PWR pin can be used either to lower the core voltage to a value defined in the VDCDC2 register when the application processor is in deep sleep mode, or to disable the core converter. An active signal at LOW\_PWR is ignored if the ENABLE\_LP bit is not set in the VDCDC1 register.

The step-down converter outputs (when enabled) are monitored by power-good comparators, the outputs of which are available through the serial interface. The outputs of the DC-DC converters can be optionally discharged when the DC-DC converters are disabled.

During PWM operation, the converters use a fast response voltage-mode controller scheme with input voltage feed-forward to achieve good line and load regulation, allowing the use of small ceramic input and output capacitors. At the beginning of each clock cycle, initiated by the clock signal, the P-channel MOSFET switch is turned on, and the inductor current ramps up until the comparator trips and the control logic turns off the switch. The current limit comparator also turns off the switch if the current limit of the P-channel switch is exceeded. After the dead time preventing current shoot through, the N-channel MOSFET rectifier is turned on, and the inductor current ramps down. The next cycle is initiated by the clock signal, again turning off the N-channel rectifier and turning on the P-channel switch.

The error amplifier, together with the input voltage, determines the rise time of the saw-tooth generator, and therefore any change in input voltage or output voltage directly controls the duty cycle of the converter, giving a good line and load transient regulation.

The two DC-DC converters operate synchronized to each other, with the MAIN converter as the master. A 270° phase shift between the MAIN switch turnon and the CORE switch turnon decreases the input RMS current, and smaller input capacitors can be used. This is optimized for a typical application where the MAIN converter regulates a Li-ion battery voltage of 3.7 V to 3.3 V and the CORE from 3.7 V to 1.5 V.

#### 7.3.1.1 Forced PWM

The core and main converters are forced into PWM mode by setting bit 7 in the VDCDC1 register. This feature is used to minimize ripple on the output voltages.

#### 7.3.1.2 Dynamic Voltage Positioning

As described in the power-save mode operation sections and as detailed in [Figure 11](#), the output voltage is typically 1.2% above the nominal output voltage at light load currents, as the device is in power-save mode. This gives additional headroom for the voltage drop during a load transient from light load to full load. During a load transient from full load to light load, the voltage overshoot is also minimized due to active regulation turning on the N-channel rectifier switch.

#### 7.3.1.3 Soft-Start

Both converters have an internal soft-start circuit that limits the inrush current during start-up. The soft start is implemented as a digital circuit, increasing the switch current in 4 steps up to the typical maximum switch current limit of 700 mA (core) and 1.75 A (main). Therefore, the start-up time mainly depends on the output capacitor and load current.

## Feature Description (continued)

### 7.3.1.4 100% Duty Cycle Low Dropout Operation

The TPS65014 converters offer a low input to output voltage difference while maintaining operation with the use of the 100% duty cycle mode. In this mode, the P-channel switch is constantly turned on. This is particularly useful in battery-powered applications to achieve longest operation time by taking full advantage of the whole battery voltage range. The minimum input voltage to maintain regulation depends on the load current and output voltage and is calculated in [Equation 1](#):

$$V_{I(\min)} = V_{O(\max)} + I_{O(\max)} \times (r_{DS(on)\max} + R_L)$$

where

- $I_{O(\max)}$  = maximum output current plus inductor ripple current
  - $r_{DS(on)\max}$  = maximum P-channel switch  $r_{DSon}$
  - $R_L$  = DC resistance of the inductor
  - $V_{O(\max)}$  = nominal output voltage plus maximum output voltage tolerance
- (1)

### 7.3.1.5 Active Discharge When Disabled

When the CORE and MAIN converters are disabled, due to an UVLO, BATT\_COVER, or OVERTEMP condition, it is possible to actively pull down the outputs. This feature is disabled per default and is individually enabled through the VDCDC1 and VDCDC2 registers in the serial interface. When this feature is enabled, the core and main outputs are discharged by a 400-Ω (typical) load.

### 7.3.1.6 Power-Good Monitoring

Both the MAIN and CORE converters have power-good comparators. Each comparator indicates when the relevant output voltage has dropped 10% below its target value, with 5% hysteresis. The outputs of these comparators are available in the REGSTATUS register through the serial interface. A maskable interrupt is generated when any voltage rail drops below the 10% threshold. The comparators are disabled when the converters are disabled. The status of the power-good comparator for VMAIN is used to generate the RESPWRON signal.

### 7.3.1.7 Overtemperature Shutdown

The MAIN and CORE converters are automatically shut down if the temperature exceeds the trip point (see [Electrical Characteristics](#)). This detection is only active if the converters are in PWM mode, either by setting FPWM = 1, or if the output current is high enough that the device runs in PWM mode automatically.

## 7.3.2 Low-Dropout Voltage Regulators

The low-dropout voltage regulators are designed to operate with low value ceramic input and output capacitors. They operate with input voltages down to 1.8 V. The LDOs offer a maximum dropout voltage of 300 mV at rated output current. Each LDO has a current limit feature. Both LDOs are enabled per default; both LDOs can be disabled or programmed through the serial interface using the VREGS1 register. The LDO outputs (when enabled) are monitored by power-good comparators, the outputs of which are available through the serial interface. The LDOs also have reverse conduction prevention when disabled. This allows the possibility to connect external regulators in parallel in systems with a backup battery.

### 7.3.2.1 Power-Good Monitoring

Both the LDO1 and LDO2 linear regulators have power-good comparators. Each comparator indicates when the relevant output voltage has dropped 10% below its target value, with 5% hysteresis. The outputs of these comparators are available in the REGSTATUS register through the serial interface. An interrupt is generated when any voltage rail drops below the 10% threshold. The LDO2 comparator is disabled when LDO2 is disabled.

## Feature Description (continued)

### 7.3.2.2 Enabling and Sequencing

Enabling and sequencing of the DC-DC converters and LDOs are described in the power-up sequencing section. The OMAP1510 processor from Texas Instruments requires that the core power supply is enabled before the I/O power supply, which means that the CORE converter should power up before the MAIN converter. This is achieved by connecting PS\_SEQ to GND.

### 7.3.3 Undervoltage Lockout

The undervoltage lockout circuit for the four regulators on TPS65014 prevents the device from malfunctioning at low input voltages and from excessive discharge of the battery. Basically, it prevents the converter from turning on the power switch or rectifier FET under undefined conditions. The undervoltage threshold voltage is set by default to 2.75 V. After power up, the threshold voltage can be reprogrammed through the serial interface. The undervoltage lockout comparator compares the voltage on the VCC pin with the UVLO threshold. When the VCC voltage drops below this threshold, the TPS65014 sets the PWRFAIL pin low and after a time  $t_{(UVLO)}$  disables the voltage regulators in the sequence defined by PS\_SEQ. The same procedure is followed when the TPS65014 detects that its junction temperature has exceeded the overtemperature threshold, typically 160°C, with a delay  $t_{(overtemp)}$ . The TPS65014 automatically restarts when the UVLO (or overtemperature) condition is no longer present.

The battery charger circuit has a separate UVLO circuit with a threshold of typically 2.5 V, which is compared with the voltage on AC and USB supply pins.

### 7.3.4 Power-Up Sequencing

The TPS65014 power-up sequencing is designed to allow the maximum flexibility without generating excessive logistical or system complexity. The relevant control pins are described in [Table 2](#).

**Feature Description (continued)**
**Table 2. Control Pins**

PIN NAME	INPUT/OUTPUT	FUNCTION
PS_SEQ	I	Input signal indicating power-up and power-down sequence of the switching converters. PS_SEQ = 0 forces the core regulator to ramp up first and down last. PS_SEQ = 1 forces the main regulator to ramp up first and down last.
DEFCORE	I	Defines the default voltage of the V <sub>CORE</sub> switching converter. DEFCORE = 0 defaults V <sub>CORE</sub> to 1.5 V, DEFCORE = V <sub>CC</sub> defaults V <sub>CORE</sub> to 1.8 V.
DEFMAIN	I	Defines the default voltage of the V <sub>MAIN</sub> switching converter. DEFMAIN = 0 defaults V <sub>MAIN</sub> to 3 V, DEFMAIN = V <sub>CC</sub> defaults V <sub>MAIN</sub> to 3.3 V.
LOW_PWR	I	The LOW_PWR pin is used to lower V <sub>CORE</sub> to the preset voltage in the VDCDC2 register when the processor is in deep sleep mode. Alternatively, V <sub>CORE</sub> can be disabled in low power mode if the LP_COREOFF bit is set in the VDCDC2 register. LOW_PWR is ignored if the ENABLE LP bit is not set in the VDCDC1 register. The TPS65014 uses the rising edge of the internal signal formed by a logical AND of LOW_PWR and ENABLE LP to enter low power mode. TPS65014 is forced out of low power mode by deasserting LOW_PWR, by resetting ENABLE LP to 0, by activating the PB_ONOFF pin or by activating the HOT_RESET pin. There are two ways to get the device back into low power mode: a) toggle the LOW_PWR pin, or b) toggle the low power bit when the LOW_PWR pin is held high. The LOW_PWR pin is also used to set the TPS65014 into WAIT mode. If USB or AC is present, the AUA bit (CHCONFIG<7>) must be set to enter the WAIT mode, see <a href="#">Figure 23</a> .
PB_ONOFF	I	PB_ONOFF can be used to exit the low power mode and return the core voltage to the value before low power mode was entered. If PB_ONOFF is used to exit the low power mode, then the low power mode can be reentered by toggling the LOW_PWR pin or by toggling the low power bit when the LOW_PWR pin is held high. A 1-M $\Omega$ pulldown resistor is integrated in TPS65014. PB_ONOFF is internally de-bounced by the TPS65014. A maskable interrupt is generated when PB_ONOFF is activated.
HOT_RESET	I	The HOT_RESET pin has a similar functionality to the PB_ONOFF pin. In addition, it generates a reset (MPU_RESET) for the MPU when the V <sub>CORE</sub> voltage is in regulation. HOT_RESET does not alter any TPS65014 settings unless low power mode was active in which case it is exited. A 1-M $\Omega$ pullup resistor to V <sub>CC</sub> is integrated in TPS65014. HOT_RESET is internally de-bounced by the TPS65014.
BATT_COVER	I	The BATT_COVER pin is used as an early warning that the main battery is about to be removed. BATT_COVER = V <sub>CC</sub> indicates that the cover is in place, BATT_COVER = 0 indicates that the cover is not in place. TPS65014 generates a maskable interrupt when the BATT_COVER pin goes low. PWRFAIL is also held low when BATT_COVER goes low. This feature may be disabled by tying BATT_COVER permanently to V <sub>CC</sub> . The TPS65014 shuts down the main and the core converter and sets the LDOs into low power mode. A 2-M $\Omega$ pulldown resistor is integrated in the TPS65014 at the BATT_COVER pin. BATT_COVER is internally de-bounced by the TPS65014.
RESPWRON	O	RESPWRON is held low while the switching converters (and any LDOs defined as default on) are starting up. It is determined by the state of MAIN's output voltage; when the voltage is higher than the power-good comparator threshold; then RESPWRON is high when V <sub>MAIN</sub> is low; then RESPWRON is low. RESPWRON is held low for t <sub>h(RESPWRON)</sub> seconds after V <sub>MAIN</sub> has settled.
MPU_RESET	O	MPU_RESET can be used to reset the processor if the user activates the HOT_RESET button. The MPU_RESET output is active for t <sub>(MPU_RESET)</sub> sec. It also forces TPS65014 to leave low power mode. MPU_RESET is also held low as long as RESPWRON is held low.
PWRFAIL	O	PWRFAIL indicates when V <sub>CC</sub> < V <sub>(UVLO)</sub> , when the TPS65014 is about to shut down due to an internal overtemperature condition or when BATT_COVER is low. PWRFAIL is also held low as long as RESPWRON is held low.
TPOR	I	TPOR is used to set the delay time for the RESPWRON reset signal. TPOR = 0 sets the delay time to 100 ms. TPOR = 1 sets the delay time to 1 s.

Figure 23 shows the state diagram for TPS65014 power sequencing. The charger function is not shown in the state diagram because this function is independent of these states.

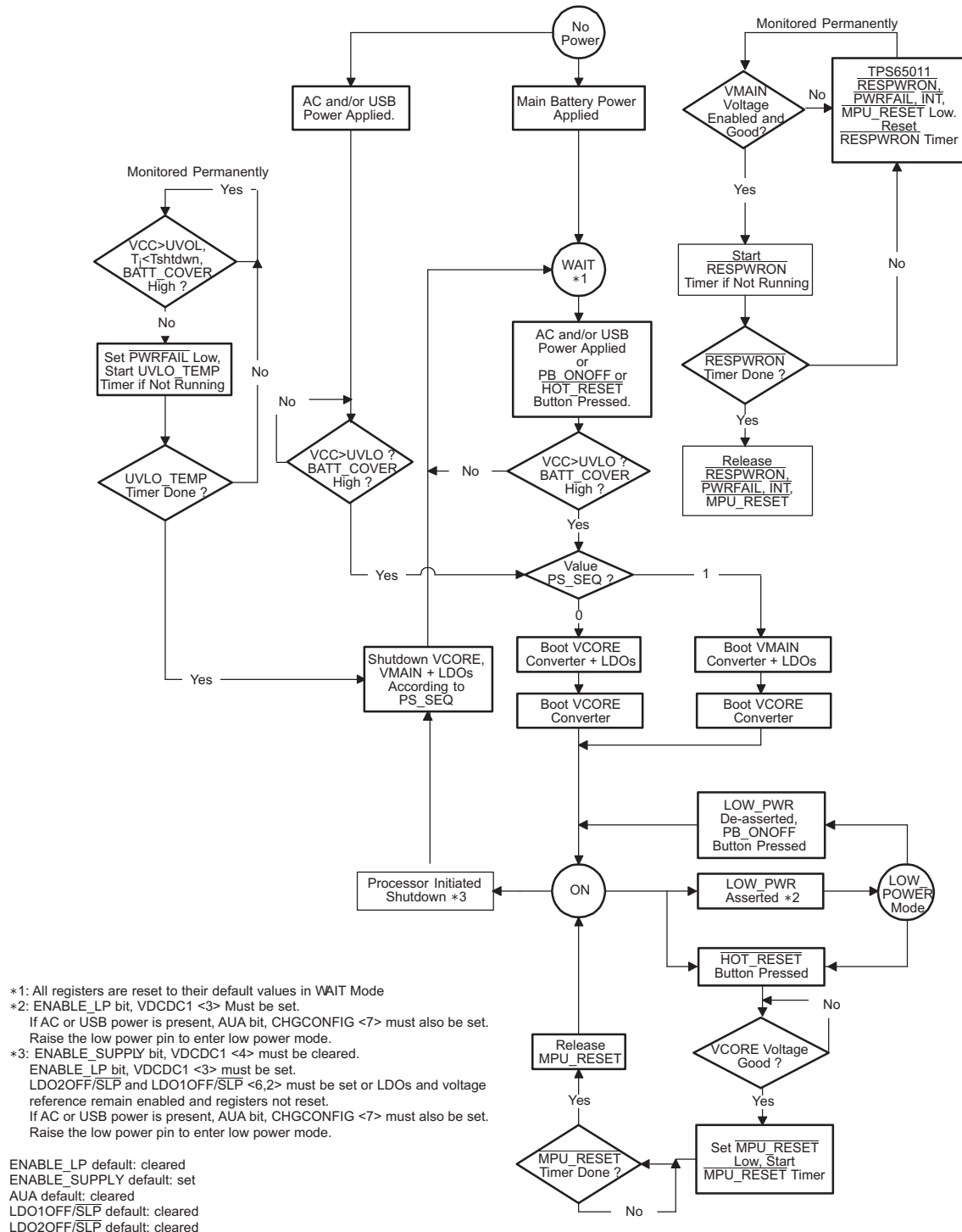

Figure 23. TPS65014 Power-On State Diagram

### 7.3.4.1 TPS65014 Power State Descriptions

#### 7.3.4.1.1 State 1: No Power

No batteries are connected to the TPS65014. When main power is applied, the bandgap reference, LDOs, and UVLO comparator start up. The  $\overline{\text{RESPWRON}}$ ,  $\overline{\text{PWRFAIL}}$ ,  $\overline{\text{INT}}$ , and  $\overline{\text{MPU\_RESET}}$  signals are held low. When  $\text{BATT\_COVER}$  goes high (de-bounced internally by the TPS65014), indicating that the battery cover has been put in place and if  $\text{VCC} > \text{UVLO}$ , the power supplies are ramped in the sequence defined by  $\text{PS\_SEQ}$ .  $\overline{\text{RESPWRON}}$ ,  $\overline{\text{PWRFAIL}}$ ,  $\overline{\text{INT}}$ , and  $\overline{\text{MPU\_RESET}}$  are released when the  $\overline{\text{RESPWRON}}$  timer has timed out after  $t_{n(\overline{\text{RESPWRON}})}$  seconds. If  $\text{VCC}$  remains valid and no  $\text{OVERTEMP}$  condition occurs, then the TPS65014 arrives in State 2: ON. If  $\text{VCC} < \text{UVLO}$ , the TPS65014 keeps the bandgap reference and UVLO comparator active such that when  $\text{VCC} > \text{UVLO}$  (during battery charge), the supplies are automatically activated.

#### 7.3.4.1.2 State 2: ON

In this state, the TPS65014 is fired up and ready for operation. The switching converter output voltages can be programmed. The LDOs can be disabled or programmed. The TPS65014 can exit this state due to an overtemperature condition, an undervoltage condition at  $\text{VCC}$ ,  $\text{BATT\_COVER}$  going low, or by the processor programming low power mode. State 2 is left temporarily if the user activates the  $\overline{\text{HOT\_RESET}}$  pin.

#### 7.3.4.1.3 State 3: Low-Power Mode

This state is entered through the processor setting the  $\text{ENABLE\_LP}$  bit in the serial interface and then raising the  $\text{LOW\_PWR}$  pin. The TPS65014 uses the rising edge of the internal signal formed by a logical AND of the  $\text{LOW\_PWR}$  and  $\text{ENABLE LP}$  signals to enter low power mode. The  $\text{VMAIN}$  switching converter remains active, but the  $\text{VCORE}$  converter may be disabled in low power mode through the serial interface by setting the  $\text{LP\_COREOFF}$  bit in the  $\text{VDCDC2}$  register. If left enabled, the  $\text{VCORE}$  voltage is set to the value predefined by the  $\text{CORELP0/1}$  bits in the  $\text{VDCDC2}$  register. The  $\text{LDO1OFF/nSLP}$  and  $\text{LDO2OFF/nSLP}$  bits in the  $\text{VREGS1}$  register determine whether the LDOs are turned off or put in a reduced power mode (transient speed-up circuitry disabled in order to minimize quiescent current) in low power mode. All TPS65014 features remain addressable through the serial interface. The TPS65014 can exit this state either due to an undervoltage condition at  $\text{VCC}$ , due to  $\text{BATT\_COVER}$  going low, due to an  $\text{OVERTEMP}$  condition, by the processor deasserting the  $\text{LOW\_POWER}$  pin, or by the user activating the  $\overline{\text{HOT\_RESET}}$  pin or the  $\text{PB\_ONOFF}$  pin.

#### 7.3.4.1.4 State 4: Shutdown

There are two scenarios for entering this state. The first is from State 1: No Power. As soon as main battery power is applied, the device automatically enters the  $\text{WAIT}$  mode.

The second scenario occurs when the device is in ON mode and the processor initiates a shutdown by resetting the  $\text{ENABLE SUPPLY}$  bit in the  $\text{VDCDC1}$  register ( $\text{ENABLE\_LP}$  must be high), and then raising the  $\text{LOW\_PWR}$  pin. When this happens, the power rails are ramped down in the predefined sequence, and all circuitry is then disabled. In this state, the TPS65014 waits for the  $\text{PB\_ONOFF}$  or  $\overline{\text{HOT\_RESET}}$  pin to be activated before enabling any of the supply rails. When the  $\text{PB\_ONOFF}$  or  $\overline{\text{HOT\_RESET}}$  pin is activated, the TPS65014 powers up the supplies according to the same constraints as at the initial application of power. Complete shutdown is only achieved by setting the  $\text{LDO1OFF/nSLP}$  and  $\text{LDO2OFF/nSLP}$  bits high in the  $\text{VREGS1}$  register before activating the shutdown.

In this case, the  $\text{I}^2\text{C}$  interface is deactivated, and the registers are reset to their default value after leaving the  $\text{WAIT}$  mode.

To enter the  $\text{WAIT}$  mode when USB or AC is present, set the  $\text{AUA}$  bit ( $\text{CHCONFIG}\langle 7 \rangle$ ). The  $\text{WAIT}$  mode is automatically left if bit 7 in register  $\text{CHCONFIG}$  is set to 0 (default), and a voltage is present at either the AC pin or the USB pin in the appropriate range for charging, and the voltage at  $\text{V}_{\text{CC}}$  is above the  $\text{UVLO}$  threshold. This feature allows the converters to start up automatically if the device is plugged in for charging.

If all supplies are turned off in  $\text{WAIT}$  mode, the internal bandgap is switched off, and the internal registers are reset to their default state when the device returns to ON mode.

[Table 3](#) lists possible configurations in LOW POWER mode and  $\text{WAIT}$  mode.

**Table 3. TPS65014 Possible Configurations<sup>(1)</sup>**

CONVERTER	MAIN	CORE	LDO1	LDO2
LOW POWER mode	1	0/1	0/1	0/1
WAIT mode	0	0	0/1	0/1

(1) 0 = converter is disabled  
1 = converter is enabled

Table 4 indicates the typical quiescent-current consumption in each power state.

**Table 4. TPS65014 Typical Current Consumption**

STATE	TOTAL QUIESCENT CURRENT	QUIESCENT CURRENT BREAKDOWN
1	0	
2	30 $\mu$ A–70 $\mu$ A	VMAIN (12 $\mu$ A) + VCORE (12 $\mu$ A) + LDOs (20 $\mu$ A each, max 2) + UVLO + reference + PowerGood
3	30 $\mu$ A–55 $\mu$ A	VMAIN (12 $\mu$ A) + VCORE (12 $\mu$ A) + LDOs (10 $\mu$ A each, max 2) + UVLO + reference + PowerGood
4	13 $\mu$ A	UVLO + reference circuitry

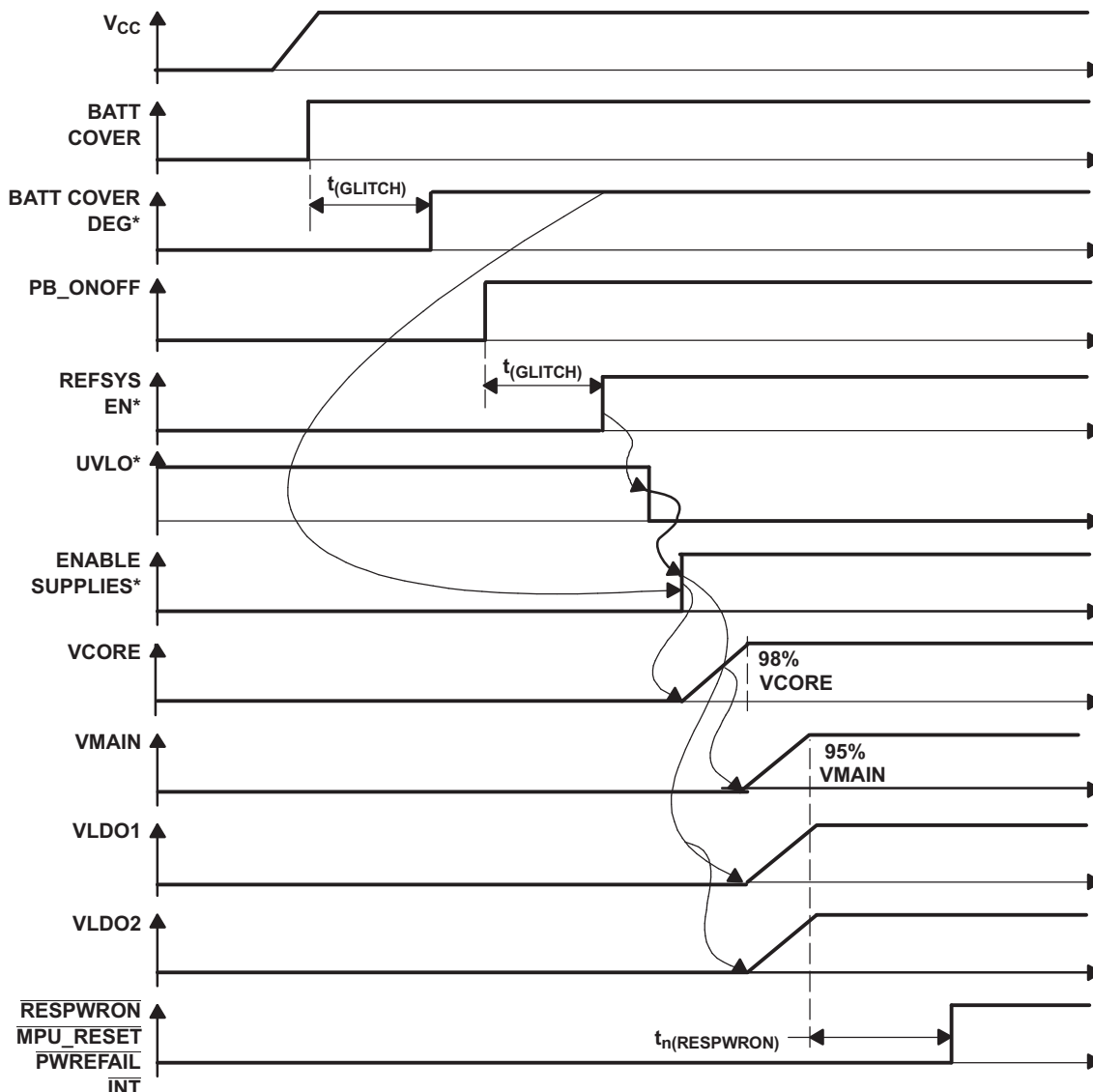

\*Internal Signal

Note: Valid for LDO1 supplied from VMAIN as described earlier in this *Application Section*.

**Figure 24. State 1 to State 2 Transition (PS\_SEQ = 0, V<sub>CC</sub> > V<sub>UVLO</sub> + HYST)**

If 2.4 ms after application V<sub>CC</sub> is still below the default UVLO threshold (3.15 V for V<sub>CC</sub> rising), then start up is as shown in [Figure 25](#).

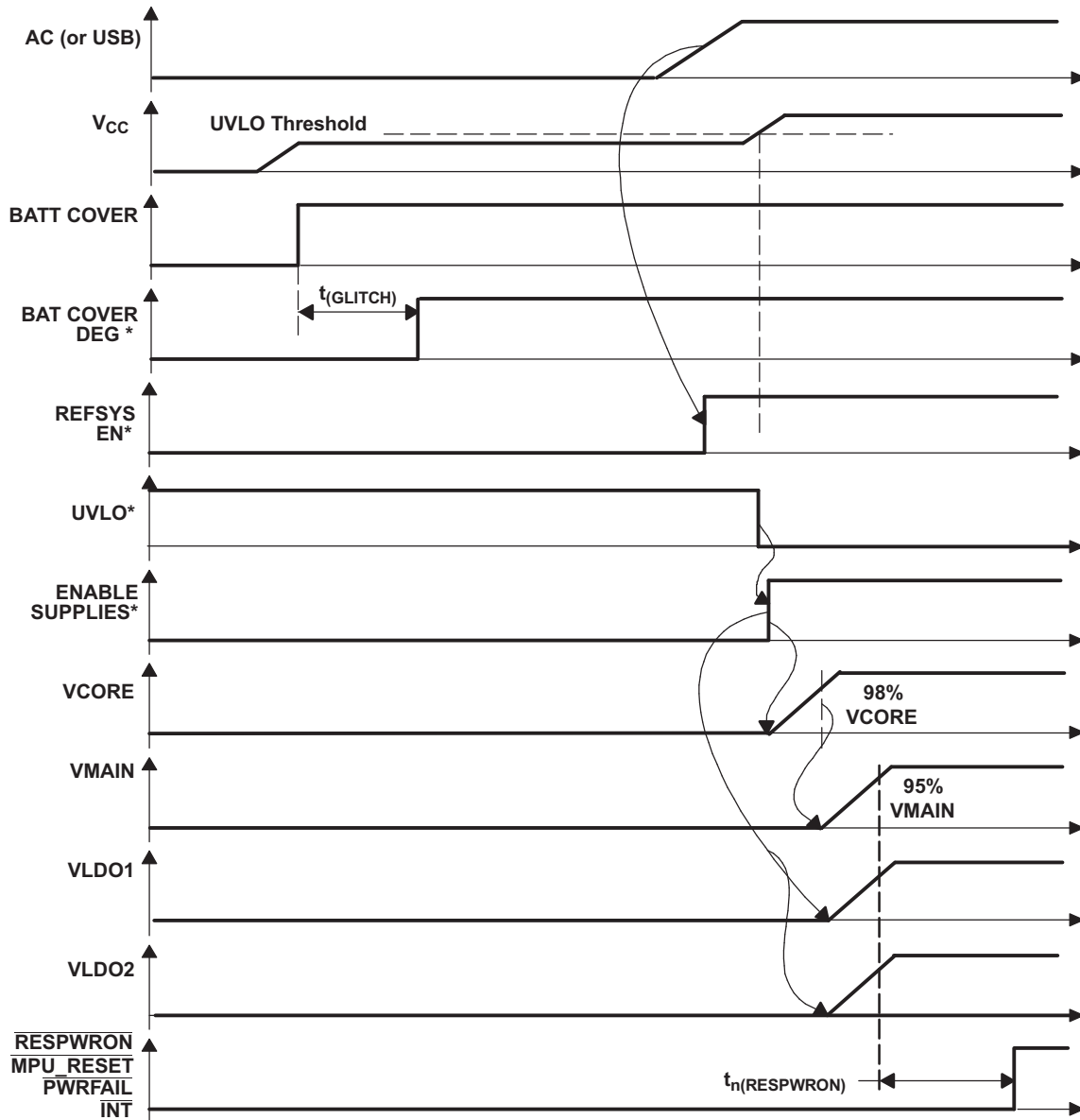

\* Internal Signal

Note: Valid for LDO1 supplied from VMAIN as described earlier in this *Application Section*

**Figure 25. State 1 to State 4 to State 2 Transition (Power-Up Behavior When Charge Voltage is Applied)**

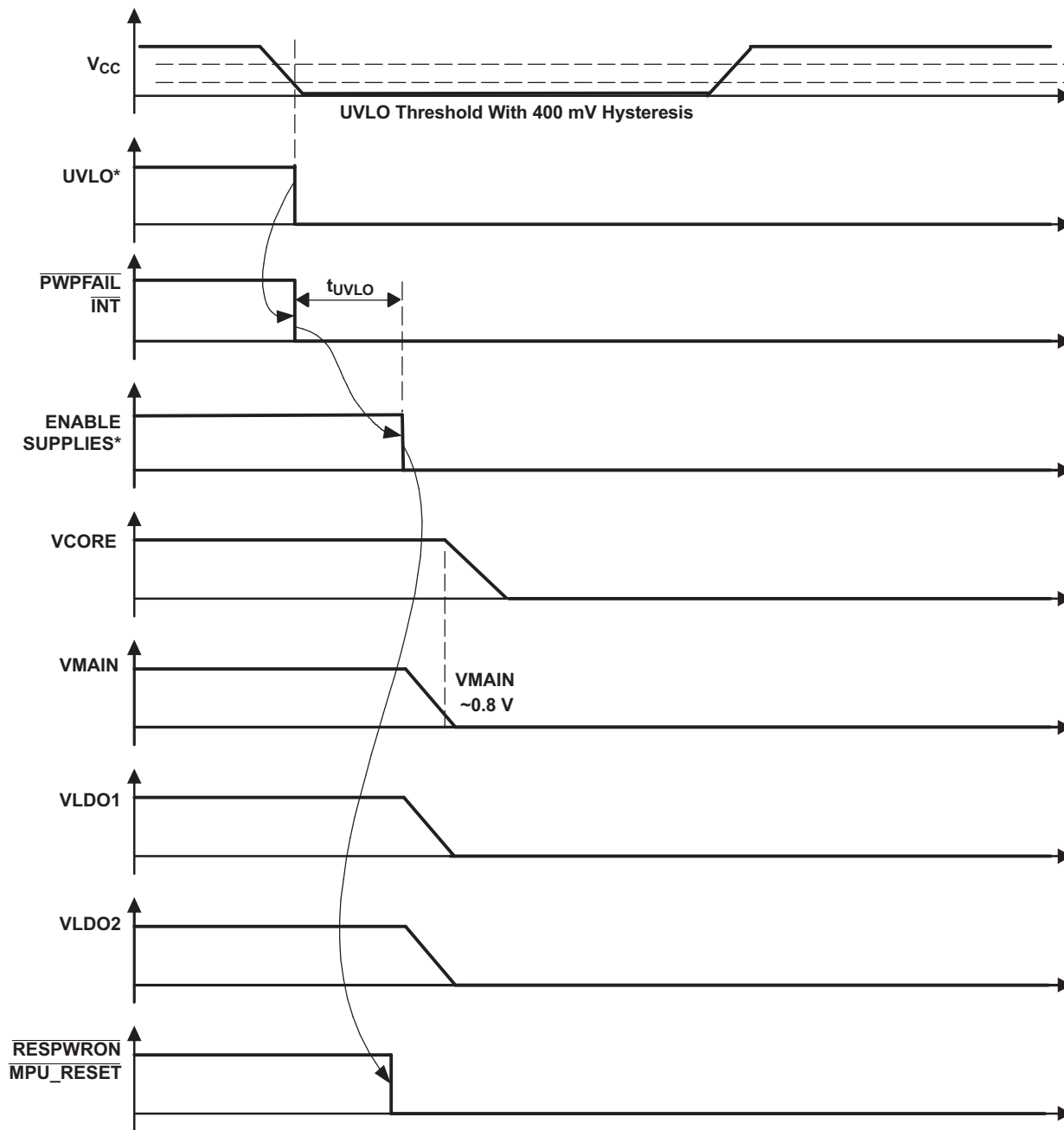

\* Internal Signal

Note: Valid for LDO1 supplied from V<sub>main</sub> as described earlier in this *Application Section*

**Figure 26. State 2 to State 4 Transition**

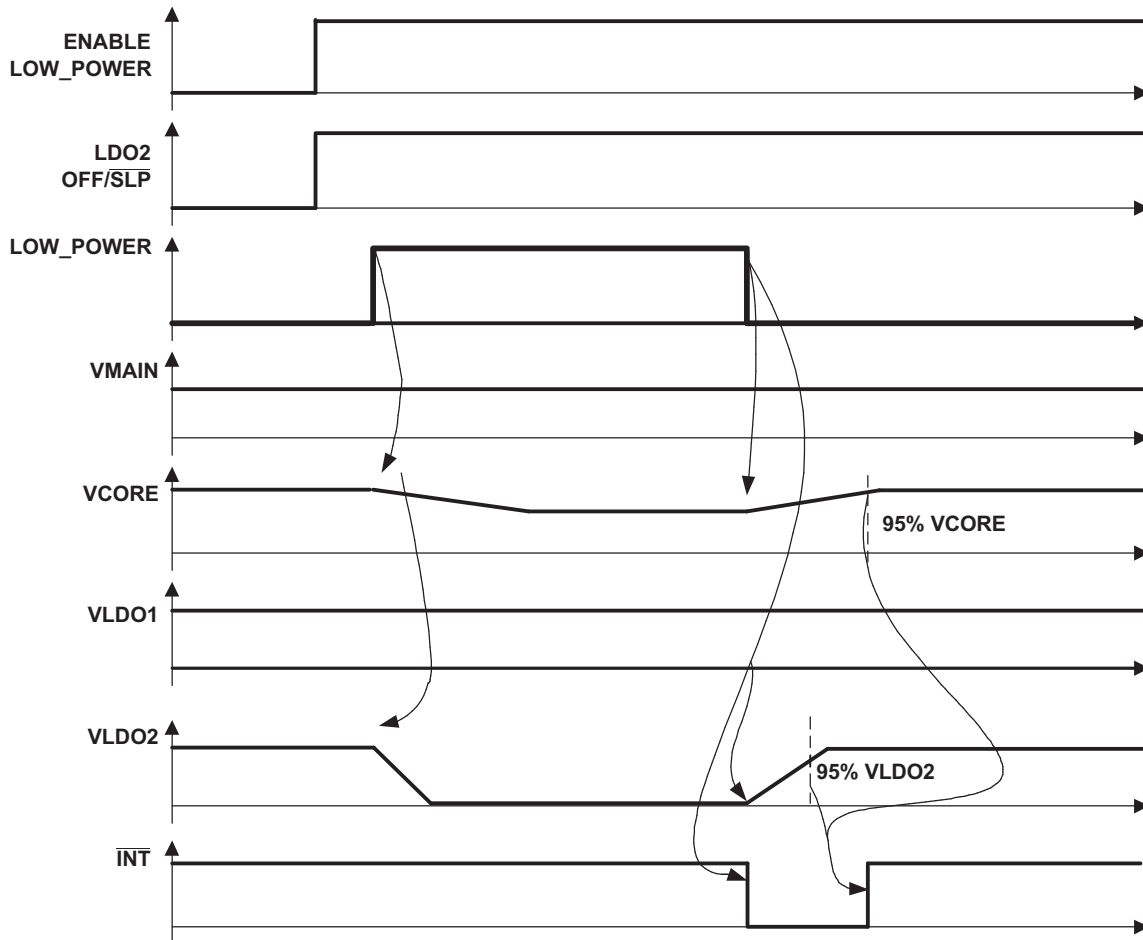

Note: VCORE Lowered, LDO2 Disabled

Note: Subsequent State 3 to State 2 Transition When LOW POWER Is Deasserted.

**Figure 27. State 2 to State 3 Transition**

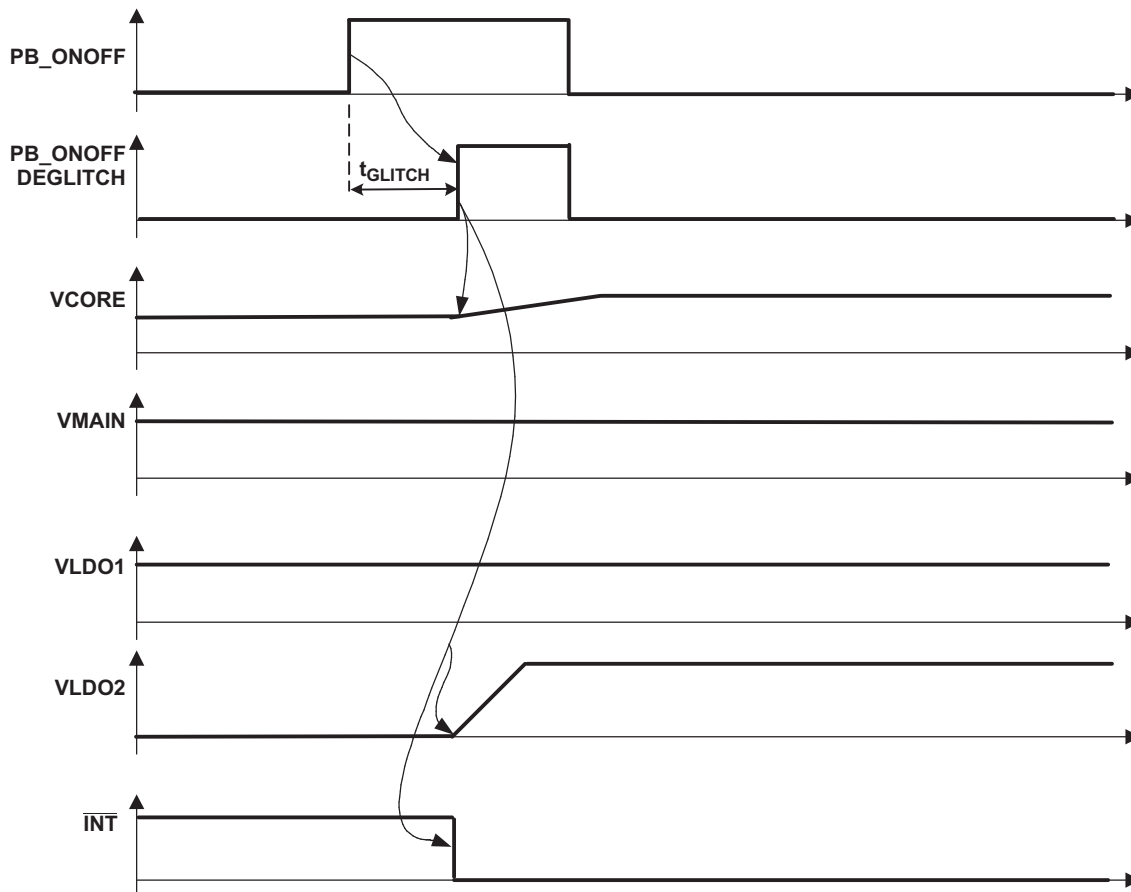

Note: PB\_ONOFF Activated (See [Interrupt Management](#) for  $\overline{INT}$  Behavior)

**Figure 28. State 3 to State 2 Transition**

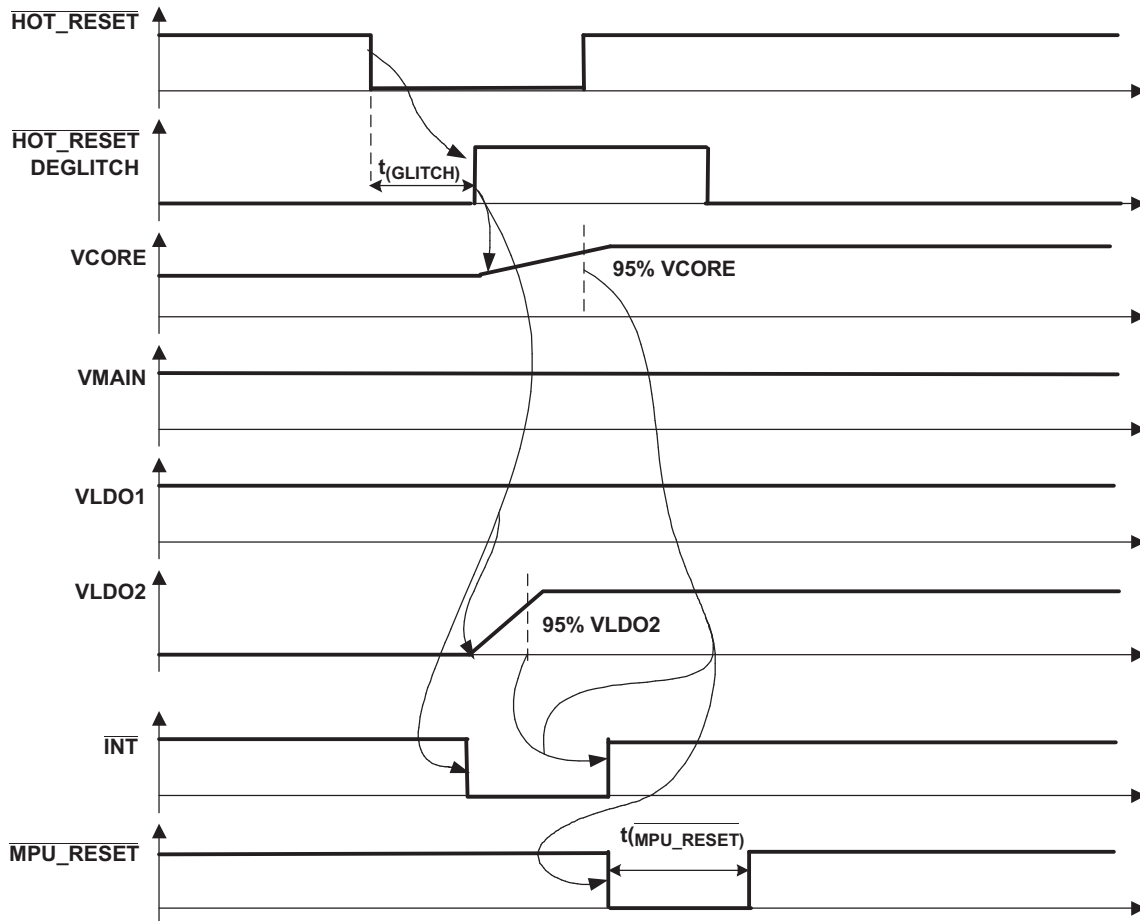

Note:  $\overline{\text{HOT\_RESET}}$  Activated (See [Interrupt Management](#) for  $\overline{\text{INT}}$  Behavior)

**Figure 29. State 3 to State 2 Transition**

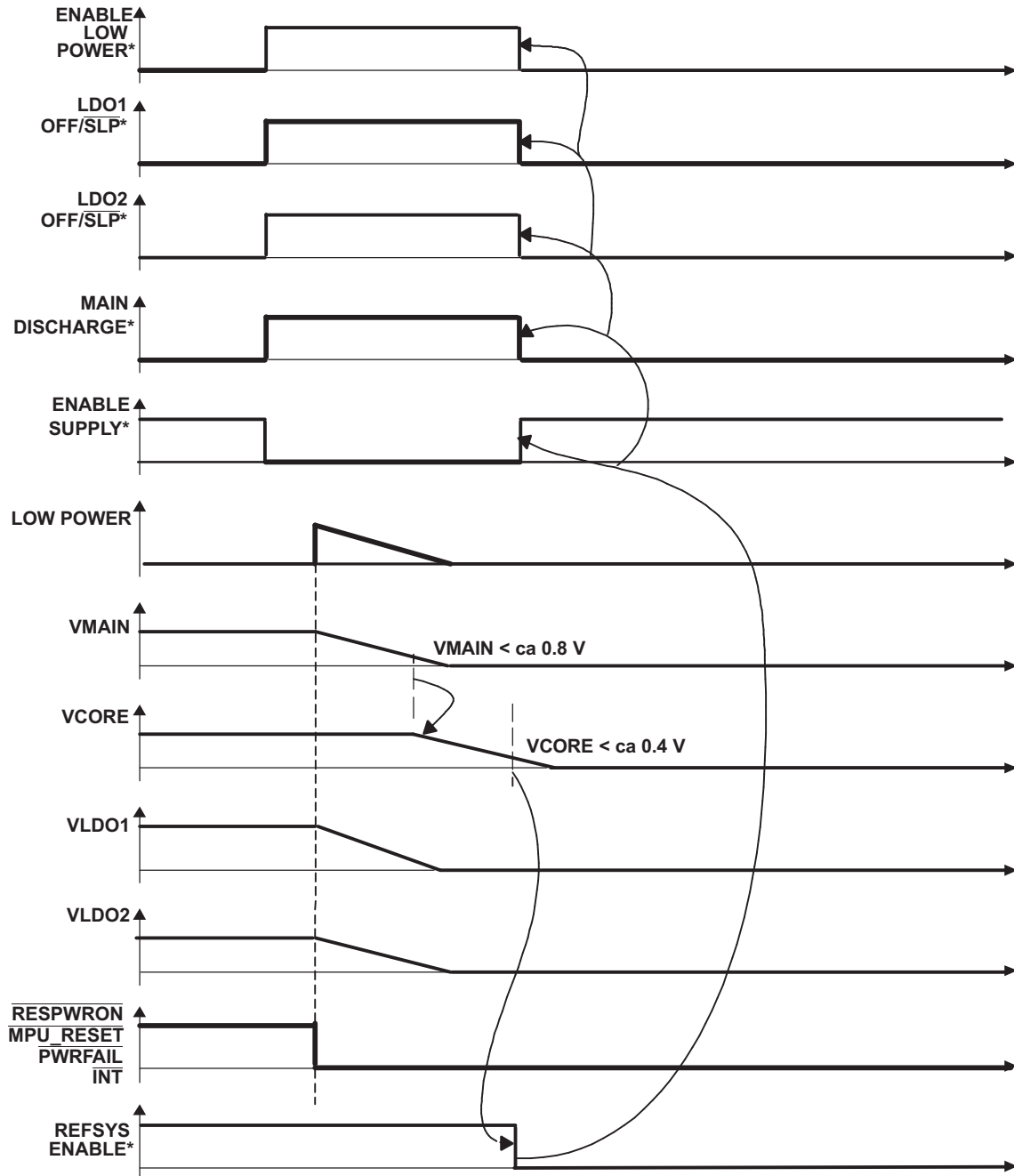

\* Internal Signal

Figure 30. State 1 to State 4 Transition

### 7.3.5 System Reset and Control Signals

The  $\overline{\text{RESPWRON}}$  signal is used as a global reset for the application. It is an open-drain output. The  $\overline{\text{RESPWRON}}$  signal is generated according to the power good comparator linked to VMAIN and remains low for  $t_{h(\overline{\text{RESPWRON}})}$  seconds after VMAIN has stabilized. When  $\overline{\text{RESPWRON}}$  is low, PWRFAIL, MPU\_RESET, and INT are also held low.

If the output voltage of MAIN is less than 90% of its nominal value, as  $\overline{\text{RESPWRON}}$  is generated, and if the output voltage of MAIN is programmed to a higher value, which causes the output voltage to fall out of the 90% window, then a  $\overline{\text{RESPWRON}}$  signal is generated.

The  $\overline{\text{PWRFAIL}}$  signal indicates when  $VCC < UVLO$  or when the TPS65014 junction temperature has exceeded a reliable value or if  $\text{BATT\_COVER}$  is taken low. This open-drain output can be connected at a fast interrupt pin for immediate attention by the application processor. All supplies are disabled  $t_{(uvlo)}$ ,  $t_{(overtemp)}$ , or  $t_{(batt\_cover)}$  seconds after  $\text{PWRFAIL}$  has gone low, giving time for the application processor to shut down cleanly.

$\text{BATT\_COVER}$  is used to detect whether the battery cover is in place or not. If the battery cover is removed, the TPS65014 generates a warning to the processor that the battery is likely to be removed and that it may be prudent to shut down the system. If not required, this feature may be disabled by connecting the  $\text{BATT\_COVER}$  pin to the  $VCC$  pin.  $\text{BATT\_COVER}$  is de-bounced internally. Typical de-bounce time is 56 ms.  $\text{BATT\_COVER}$  has an internal 2-M $\Omega$  pulldown resistor.

The  $\overline{\text{HOT\_RESET}}$  input is used to generate an  $\overline{\text{MPU\_RESET}}$  signal for the application processor. The  $\overline{\text{HOT\_RESET}}$  pin could be connected to a user-activated button in the application. It can also be used to exit low power mode. In this case, the TPS65014 waits until the  $V_{\text{CORE}}$  voltage has stabilized before generating the  $\overline{\text{MPU\_RESET}}$  pulse. The  $\overline{\text{MPU\_RESET}}$  pulse is active low for  $t_{(mpu\_nreset)}$  seconds.  $\overline{\text{HOT\_RESET}}$  has an internal 1-M $\Omega$  pullup resistor to  $V_{\text{CC}}$ .

The  $\text{PB\_ONOFF}$  input can be used to exit **LOW POWER MODE**. It is typically driven by a user-activated pushbutton in the application. Both  $\overline{\text{HOT\_RESET}}$  and  $\text{PB\_ONOFF}$  are de-bounced internally by the TPS65014. Typical debounce time is 56 ms.  $\text{PB\_ONOFF}$  has an internal 1-M $\Omega$  pulldown resistor.

$\text{PB\_ONOFF}$ ,  $\text{BATT\_COVER}$  and  $UVLO$  events also cause a normal, maskable interrupt to be generated and are noted in the  $\text{REGSTATUS}$  register.

### 7.3.6 Vibrator Driver

The  $VIB$  open-drain output is provided to drive a vibrator motor, controlled through the serial interface register  $VDCDC2$ . It has a maximum dropout of 0.5 V at 100-mA load. Typically, an external resistor is required to limit the motor current and a freewheel diode to limit the  $VIB$  overshoot voltage at turnoff.

### 7.3.7 LED2 Output

The  $\text{LED2}$  output can be programmed in the same way as the  $\overline{\text{PG}}$  output to blink or to be permanently on or off. The  $\text{LED2\_ON}$  and  $\text{LED2\_PER}$  registers are used to control the blink rate. For both  $\overline{\text{PG}}$  and  $\text{LED2}$ , the minimum blink-on time is 10 ms, and this can be increased in 127 10-ms steps to 1280 ms. For both  $\overline{\text{PG}}$  and  $\text{LED2}$ , the minimum blink period is 100 ms, and this can be increased in 127 100-ms steps to 12800 ms.

### 7.3.8 Interrupt Management

The open-drain  $\overline{\text{INT}}$  pin is used to combine and report all possible conditions through a single pin. Battery and chip temperature faults, precharge timeout, charge timeout, taper timeout, and termination current are each capable of setting  $\overline{\text{INT}}$  low, that is, active.  $\overline{\text{INT}}$  can also be activated if any of the regulators are below the regulation threshold. Interrupts can also be generated by any of the GPIO pins programmed to be inputs. These inputs can be programmed to generate an interrupt either at the rising or falling edge of the input signal. It is possible to mask an interrupt from any of these conditions individually by setting the appropriate bits in the  $\text{MASK1}$ ,  $\text{MASK2}$ , or  $\text{MASK3}$  registers. By default, all interrupts are masked. Interrupts are stored in the  $\text{CHGSTATUS}$ ,  $\text{REGSTATUS}$ , and  $\text{DEFGPIO}$  registers in the serial interface.  $\text{CHGSTATUS}$  and  $\text{REGSTATUS}$  interrupts are acknowledged by reading these registers. If a 1 is present in any location, then the TPS65014 automatically sets the corresponding bit in the  $\text{ACKINT1}$  or  $\text{ACKINT2}$  registers and releases the  $\overline{\text{INT}}$  pin. The  $\text{ACKINT}$  register contents are self-clearing when the condition, which caused the interrupt, is removed. The applications processor should not normally need to access the  $\text{ACKINT1}$  or  $\text{ACKINT2}$  registers.

Interrupt events are always captured; thus when an interrupt source is unmasked,  $\overline{\text{INT}}$  may immediately go active due to a previous interrupt condition. This can be prevented by first reading the relevant  $\text{STATUS}$  register before unmasking the interrupt source.

If an interrupt condition occurs, then the  $\overline{\text{INT}}$  pin is set low. The  $\text{CHGSTATUS}$ ,  $\text{REGSTATUS}$ , and  $\text{DEFGPIO}$  registers should be read. Bit positions containing a 1 (or possibly a 0 in  $\text{DEFGPIO}$ ) are noted by the CPU and the corresponding situation resolved. The reading of the  $\text{CHGSTATUS}$  and  $\text{REGSTATUS}$  registers automatically acknowledges any interrupt condition in those registers and blocks the path to the  $\overline{\text{INT}}$  pin from the relevant bits. No interrupt should be missed during the read process because this process starts by latching the contents of the register before shifting them out at  $\text{SDAT}$ . Once the contents have been latched (which takes a couple of nanoseconds), the register is free to capture new interrupt conditions. Thus, for practical purposes the probability of missing anything is zero.

The following describes how registers 0x01 (CHGSTATUS) and 0x02 (REGSTATUS) are handled:

- CHGSTATUS(5,0) are positive edge set. Read of set CHGSTATUS(5,0) bits sets ACKINT1(5,0) bits.
- CHGSTATUS(7-6,4-1) are level set. Read of set CHGSTATUS(7-6,4-1) bits sets ACKINT1(7-6,4-1) bits.
- CHGSTATUS(5,0) clear when input signal low, and ACKINT1(5,0) bits are already set.
- CHGSTATUS(7-6,4-1) clear when input signal is low.
- ACKINT1(7-0) clear when CHGSTATUS(7-0) is clear.
- REGSTATUS(7-5) are positive edge set. Read of set REGSTATUS(7-5) bits sets ACKINT2(7-5) bits.
- REGSTATUS(3-0) are level set. Read of set REGSTATUS(3-0) bits sets ACKINT2(3-0) bits.
- REGSTATUS(7-5) clear when input signal low, and ACKINT1(7-5) bit are already set.
- REGSTATUS(3-0) clear when input signal is low.
- ACKINT2(7-0) clear when REGSTATUS(7-0) is clear.

The following describes the function of the 0x05 (ACKINT1) and 0x06 (ACKINT2) registers. These are not usually written to by the CPU because the TPS65014 internally sets/clears these registers:

- ACKINT1(7:0): Bit is set when the corresponding CHGSTATUS set bit is read through I<sup>2</sup>C.
- ACKINT1(7:0): Bit is cleared when the corresponding CHGSTATUS set bit clears.
- ACKINT2(7:0): Bit is set when the corresponding REGSTATUS set bit is read through I<sup>2</sup>C.
- ACKINT2(7:0): Bit is cleared when the corresponding REGSTATUS set bit clears.
- ACKINT1(7:0): A bit set masks the corresponding CHGSTATUS bit from  $\overline{INT}$ .
- ACKINT2(7:0): A bit set masks the corresponding REGSTATUS bit from  $\overline{INT}$ .

The following describes the function of the 0x03 (MASK1), 0x04 (MASK2) and 0x0F (MASK3) registers:

- MASK1(7:0): A bit set in this register masks CHGSTATUS from  $\overline{INT}$ .
- MASK2(7:0): A bit set in this register masks REGSTATUS from  $\overline{INT}$ .
- MASK3(7:4): A bit set in this register detects a rising edge on GPIO.
- MASK3(7:4): A bit cleared in this register detects a falling edge on GPIO.
- MASK3(3:0): A bit set in this register clears GPIO Detect signal from  $\overline{INT}$ .

GPIO interrupts are located by reading the 0x10 (DEFGPIO) register. The application CPU stores, or can read from DEFGPIO<7:4>, which GPIO is set to input or output. This information together with the information on which edge the interrupt was generated (the CPU either knows this or can read it from MASK3<7:4>) determines whether the CPU is looking for a 0 or a 1 in DEFGPIO<3:0>. A GPIO interrupt is blocked from the  $\overline{INT}$  pin by setting the relevant MASK3<3:0> bit; this must be done by the CPU, there is no auto-acknowledge for the GPIO interrupts.

### 7.3.9 Serial Interface

The serial interface is compatible with the standard and fast mode I<sup>2</sup>C specifications, allowing transfers at up to 400 kHz. The interface adds flexibility to the power supply solution, enabling most functions to be programmed to new values depending on the instantaneous application requirements and charger status to be monitored. Register contents remain intact as long as V<sub>CC</sub> remains above 2 V. The TPS65014 has a 7-bit address with the LSB set by the IFLSB pin; this allows the connection of two devices with the same address to the same bus. The 6 MSBs are 100100. Attempting to read data from register addresses not listed in this section results in FFh being read out.

For normal data transfer, DATA is allowed to change only when CLK is low. Changes when CLK is high are reserved for indicating the start and stop conditions. During data transfer, the data line must remain stable whenever the clock line is high. There is one clock pulse per bit of data. Each data transfer is initiated with a start condition and terminated with a stop condition. When addressed, the TPS65014 device generates an acknowledge bit after the reception of each byte. The master device (microprocessor) must generate an extra clock pulse that is associated with the acknowledge bit. The TPS65014 device must pull down the DATA line during the acknowledge clock pulse so that the DATA line is a stable low during the high period of the acknowledge clock pulse. The DATA line is a stable low during the high period of the acknowledge-related clock pulse. Setup and hold times must be taken into account. During read operations, a master must signal the end of data to the slave by not generating an acknowledge bit on the last byte that was clocked out of the slave. In this case, the slave TPS65014 device must leave the data line high to enable the master to generate the stop condition.

The I<sup>2</sup>C interface accepts data as soon as the voltage at V<sub>CC</sub> is higher than the undervoltage lockout threshold and one power rail of the converter (main, core, or one of the LDOs) is operating. Therefore, the I<sup>2</sup>C interface is not operating after applying the battery voltage as the device automatically enters the WAIT mode with all rails off.

When the device is in WAIT mode, the I<sup>2</sup>C registers are reset to their default values if all voltage rails are off. If the device is in WAIT mode and one power rail is left on, the I<sup>2</sup>C interface is operating and the registers are not reset after leaving the WAIT mode.

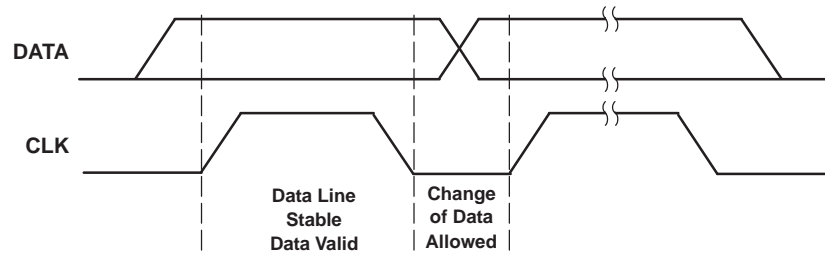

Figure 31. Bit Transfer on the Serial Interface

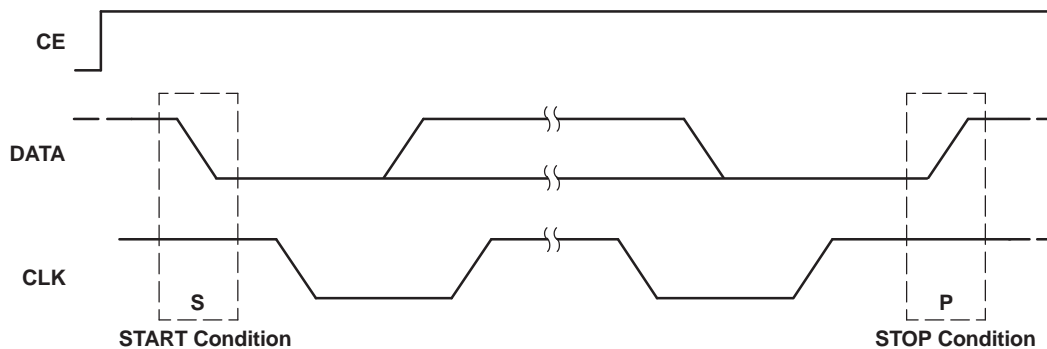
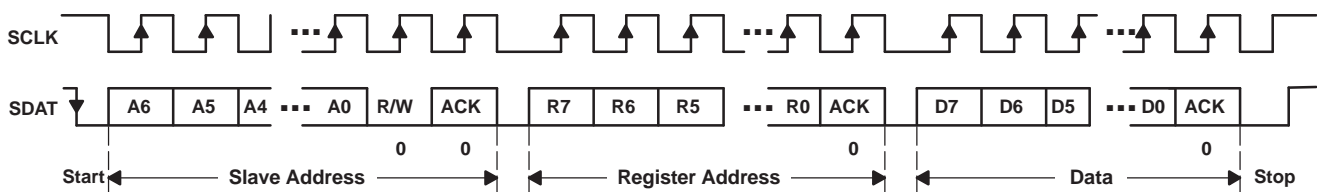
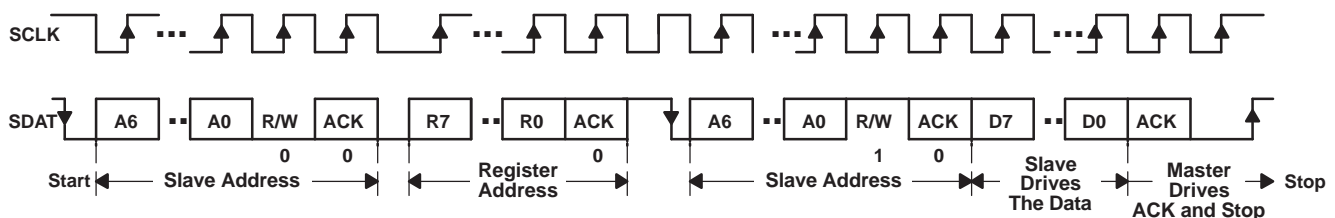

Figure 32. START and STOP Conditions



Note: SLAVE = TPS65014

Figure 33. Serial Interface WRITE to TPS65014 Device



Note: SLAVE = TPS65014

Figure 34. Serial Interface READ From TPS65014: Protocol A

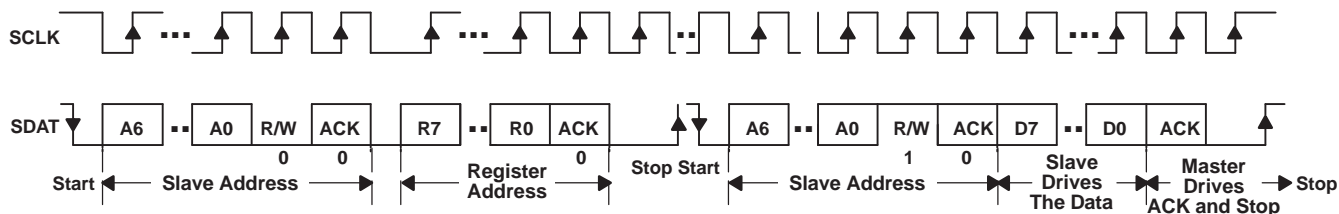

Note: SLAVE = TPS65014

**Figure 35. Serial Interface READ From TPS65014: Protocol B**

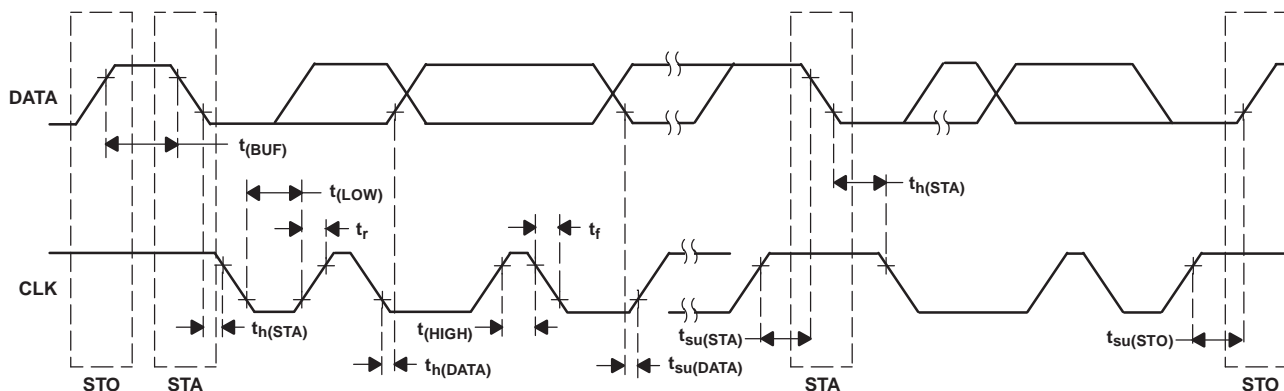

**Figure 36. Serial Interface Timing Diagram**

## 7.4 Device Functional Modes

### 7.4.1 Power Save Mode Operation

As the load current decreases, the converter enters the power-save mode operation. During power-save mode, the converter operates with reduced switching frequency in PFM mode and with a minimum quiescent current to maintain high efficiency.

To optimize the converter efficiency at light load, the average current is monitored; if in PWM mode, the inductor current remains below a certain threshold, and then power-save mode is entered. The typical threshold can be calculated as in Equation 2:

$$I_{(\text{skipmain})} = \frac{V_{I(\text{MAIN})}}{17 \Omega} \quad I_{(\text{skipcore})} = \frac{V_{I(\text{CORE})}}{42 \Omega} \quad (2)$$

During the power-save mode, the output voltage is monitored with the comparator by the thresholds comp low and comp high. As the output voltage falls below the comp low threshold, set to typically 0.8% above the nominal  $V_{\text{out}}$ , the P-channel switch turns on. The converter then runs at 50% of the nominal switching frequency. If the load is below the delivered current, then the output voltage rises until the comp high threshold is reached, typically 1.6% above the nominal  $V_{\text{out}}$ . At this point, all switching activity ceases, thus reducing the quiescent current to a minimum until the output voltage has dropped below comp low again. If the load current is greater than the delivered current, then the output voltage falls until it crosses the nominal output voltage threshold (comp low 2 threshold), whereupon power-save mode is exited, and the converter returns to PWM mode.

These control methods reduce the quiescent current typically to 12  $\mu\text{A}$  per converter and the switching frequency to a minimum, achieving the highest converter efficiency. Setting the comparator thresholds to typically 0.8% and 1.6% above the nominal output voltage at light load current results in a dynamic voltage positioning achieving lower absolute voltage drops during heavy load transient changes. This allows the converters to operate with a small output capacitor of just 10  $\mu\text{F}$  for the core and 22  $\mu\text{F}$  for the main output and still have a low absolute voltage drop during heavy load transient changes. See Figure 37 for detailed operation of the power-save mode. The power-save mode can be disabled through the I<sup>2</sup>C interface to force the converters to stay in fixed frequency PWM mode.

**Device Functional Modes (continued)**

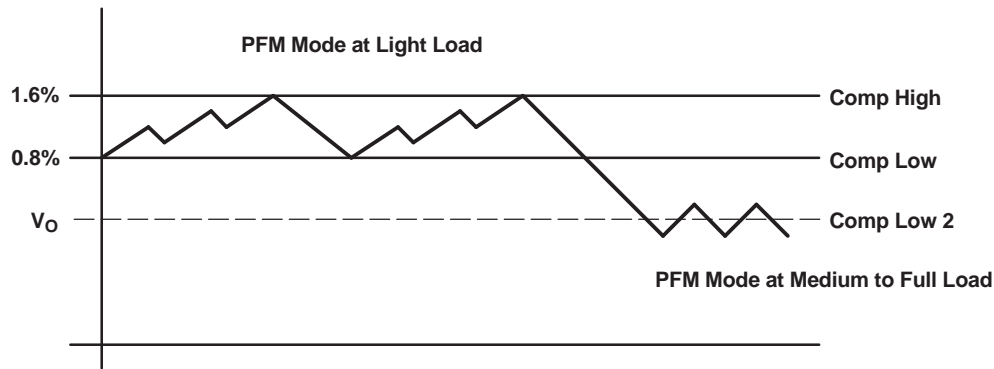

**Figure 37. Power-Save Mode Thresholds and Dynamic Voltage Positioning**

**7.4.2 Sleep Mode**

The TPS65014 charger enters the low-power sleep mode if both input sources are removed from the circuit. This feature prevents draining the battery during the absence of input power.

**7.5 Register Maps**

**7.5.1 CHGSTATUS Register (offset = 01h) (reset: 00h)**

Bits 1-4 may be reset through the serial interface in order to force a reset of the charger. Any attempt to write to Bit 0 and Bits 5-7 is ignored. A 1 in <7:0> sets the INT pin active unless the corresponding bit in the MASK register is set.

**Figure 38. CHGSTATUS Register**

7	6	5	4	3	2	1	0
USB Charge	AC Charge	Thermal Suspend	Term Current	Taper Timeout	Chg Timeout	Prechg Timeout	BattTemp Error
R-0	R-0	R-0	R-0	R/W-0	R/W-0	R/W-0	R-0

LEGEND: R/W = Read/Write; R = Read only; -n = value after reset

**Table 5. CHGSTATUS Register Field Descriptions**

BIT	FIELD	TYPE	RESET	DESCRIPTION
7	USB charge	R	0h	0h = Inactive 1h = USB source is present and in the range valid for charging. B7 remains active as long as the charge source is present.
6	AC charge	R	0h	0h = Wall plug source is not present and/or not in the range valid for charging 1h = Wall plug source is present and in the range valid for charging. B6 remains active as long as the charge source is present.
5	Thermal suspend	R	0h	0h = Charging is allowed 1h = Charging is momentarily suspended due to excessive power dissipation on chip.
4	Term current	R	0h	0h = Charging, charge termination current threshold has not been crossed. 1h = Charge termination current threshold has been crossed and charging has been stopped. This can be due to a battery reaching full capacity, or to a battery removal condition.

**Table 5. CHGSTATUS Register Field Descriptions (continued)**

BIT	FIELD	TYPE	RESET	DESCRIPTION
3	Taper Timeout	R/W	0h	<p>If CHCONFIG&lt;5&gt;=0: Bit 3 equals the output of the taper voltage comparator directly, without any timer delay.</p> <p>If CHCONFIG&lt;5&gt;=1: there is a delay of 30 minutes because the timers have to time out first.</p> <p>0h = Charging, timers did not time out</p> <p>1h = One of the timers has timed out and charging has been terminated.</p>
2	Chg Timeout	R/W	0h	<p>If CHCONFIG&lt;5&gt;=0: Bit 3 equals the output of the taper voltage comparator directly, without any timer delay.</p> <p>If CHCONFIG&lt;5&gt;=1: there is a delay of 30 minutes because the timers have to time out first.</p> <p>0h = Charging, timers did not time out</p> <p>1h = One of the timers has timed out and charging has been terminated.</p>
1	Prechg Timeout	R/W	0h	<p>If CHCONFIG&lt;5&gt;=0: Bit 3 equals the output of the taper voltage comparator directly, without any timer delay.</p> <p>If CHCONFIG&lt;5&gt;=1: there is a delay of 30 minutes because the timers have to time out first.</p> <p>0h = Charging, timers did not time out</p> <p>1h = One of the timers has timed out and charging has been terminated.</p>
0	BattTempError	R	0h	<p>Battery temperature error</p> <ul style="list-style-type: none"> <li>0 = Battery temperature is inside the allowed range and that charging is allowed.</li> <li>1 = Battery temperature is outside of the allowed range and that charging is suspended.</li> </ul>

### 7.5.2 REGSTATUS Register (offset = 02h) (reset: 00h)

A rising edge in the REGSTATUS register contents causes  $\overline{\text{INT}}$  to be driven low if it is not masked in the MASK2.

**Figure 39. REGSTATUS Register**

7	6	5	4	3	2	1	0
PB_ONOFF	BATT_COVER	UVLO	Rsvd	$\overline{\text{P}}\text{GOOD LDO2}$	$\overline{\text{P}}\text{GOOD LDO1}$	$\overline{\text{P}}\text{GOOD MAIN}$	$\overline{\text{P}}\text{GOOD CORE}$
R-0	R-0	R-0	R-0	R-0	R-0	R-0	R-0

LEGEND: R/W = Read/Write; R = Read only; -n = value after reset

**Table 6. REGSTATUS Register Field Descriptions**

BIT	FIELD	TYPE	RESET	DESCRIPTION
7	PB_ONOFF	R	0h	0h = Inactive 1h = User activated the PB_ONOFF switch to request that all rails are shut down.
6	BATT_COVER	R	0h	0h = BATT_COVER pin is high 1h = BATT_COVER pin is low
5	UVLO	R	0h	0h = Voltage at the VCC pin above UVLO threshold 1h = Voltage at the VCC pin has dropped below the UVLO threshold
4	Reserved	R	0h	
3	$\overline{\text{P}}\text{GOOD LDO2}$	R	0h	0h = LDO2 output in regulation, or LDO2 disabled with VREGS1 <7> = 0 1h = LDO2 output out of regulation
2	$\overline{\text{P}}\text{GOOD LDO1}$	R	0h	0h = LDO1 output in regulation, or LDO1 disabled with VREGS1 <3> = 0 1h = LDO1 output out of regulation
1	$\overline{\text{P}}\text{GOOD MAIN}$	R	0h	0h = Main converter output in regulation 1h = Main converter output out of regulation
0	$\overline{\text{P}}\text{GOOD CORE}$	R	0h	0h = Core converter output in regulation 1h = Core converter output out of regulation, or VDCDC2 <7> = 1 in low power mode

### 7.5.3 MASK1 Register (offset = 03h) (reset: FFh)

The MASK1 register is used to mask all or any of the conditions in the corresponding CHGSTATUS<7:0> positions indicated at the INT pin. Default is to mask all.

**Figure 40. MASK1 Register**

7	6	5	4	3	2	1	0
Mask USB	Mask AC	Mask Thermal Suspend	Mask Term	Mask Taper	Mask Chg	Mask Prechg	Mask BattTemp
R/W-1	R/W-1	R/W-1	R/W-1	R/W-1	R/W-1	R/W-1	R/W-1

LEGEND: R/W = Read/Write; R = Read only; -n = value after reset

**Table 7. MASK1 Register Field Descriptions**

BIT	FIELD	TYPE	RESET	DESCRIPTION
7	Mask USB	R/W	1h	INT Mask for Bit 7 in CHGSTATUS register. Refer to <a href="#">Table 5</a> .
6	Mask AC	R/W	1h	INT Mask for Bit 6 in CHGSTATUS register. Refer to <a href="#">Table 5</a> .
5	Mask Thermal Suspend	R/W	1h	INT Mask for Bit 5 in CHGSTATUS register. Refer to <a href="#">Table 5</a> .
4	Mask Term	R/W	1h	INT Mask for Bit 4 in CHGSTATUS register. Refer to <a href="#">Table 5</a> .
3	Mask Taper	R/W	1h	INT Mask for Bit 3 in CHGSTATUS register. Refer to <a href="#">Table 5</a> .
2	Mask Chg	R/W	1h	INT Mask for Bit 2 in CHGSTATUS register. Refer to <a href="#">Table 5</a> .
1	Mask Prechg	R/W	1h	INT Mask for Bit 1 in CHGSTATUS register. Refer to <a href="#">Table 5</a> .
0	Mask BattTemp	R/W	1h	INT Mask for Bit 0 in CHGSTATUS register. Refer to <a href="#">Table 5</a> .

### 7.5.4 MASK2 Register (offset = 04h) (reset: FFh)

The MASK2 register is used to mask all or any of the conditions in the corresponding REGSTATUS<7:0> positions indicated at the INT pin. Default is to mask all.

**Figure 41. MASK2 Register**

7	6	5	4	3	2	1	0
Mask PB_ONOFF	Mask BATT_COVER	Mask UVLO	Rsvd	Mask PGOOD LDO2	Mask PGOOD LDO1	Mask PGOOD MAIN	Mask PGOOD CORE
R/W-1	R/W-1	R/W-1	R/W-1	R/W-1	R/W-1	R/W-1	R/W-1

LEGEND: R/W = Read/Write; R = Read only; -n = value after reset

**Table 8. MASK2 Register Field Descriptions**

BIT	FIELD	TYPE	RESET	DESCRIPTION
7	Mask PB_ONOFF	R/W	1h	INT Mask for Bit 7 in REGSTATUS register. Refer to <a href="#">Table 6</a> .
6	Mask BATT_COVER	R/W	1h	INT Mask for Bit 6 in REGSTATUS register. Refer to <a href="#">Table 6</a> .
5	Mask UVLO	R/W	1h	INT Mask for Bit 5 in REGSTATUS register. Refer to <a href="#">Table 6</a> .
4	Reserved	R/W	1h	Reserved
3	Mask PGOOD LDO2	R/W	1h	INT Mask for Bit 3 in REGSTATUS register. Refer to <a href="#">Table 6</a> .
2	Mask PGOOD LDO1	R/W	1h	INT Mask for Bit 2 in REGSTATUS register. Refer to <a href="#">Table 6</a> .
1	Mask PGOOD MAIN	R/W	1h	INT Mask for Bit 1 in REGSTATUS register. Refer to <a href="#">Table 6</a> .
0	Mask PGOOD CORE	R/W	1h	INT Mask for Bit 0 in REGSTATUS register. Refer to <a href="#">Table 6</a> .

### 7.5.5 ACKINT1 Register (offset = 05h) (reset: 00h)

The ACKINT1 register is internally used to acknowledge any of the interrupts in the corresponding CHGSTATUS<7:0> positions. When this is done, the acknowledged interrupt is no longer fed through to the INT pin and so the INT pin becomes free to indicate the next pending interrupt. If none exists, then the INT pin goes high, else it will remain low. A 1 at any position in ACKINT1 is automatically cleared when the corresponding interrupt condition in CHGSTATUS is removed. The application processor should not normally need to access the ACKINT1 register.

**Figure 42. ACKINT1 Register**

7	6	5	4	3	2	1	0
Ack USB	Ack AC	Ack Thermal Shutdown	Ack Term	Ack Taper	Ack Chg	Ack Prechg	Ack BattTemp
R-0	R-0	R-0	R-0	R-0	R-0	R-0	R-0

LEGEND: R/W = Read/Write; R = Read only; -n = value after reset

**Table 9. ACKINT1 Register Field Descriptions**

BIT	FIELD	TYPE	RESET	DESCRIPTION
7	Ack USB	R	0h	Internal ack for Bit 7 in CHGSTATUS register. Refer to <a href="#">Table 5</a> .
6	Ack AC	R	0h	Internal ack for Bit 6 in CHGSTATUS register. Refer to <a href="#">Table 5</a> .
5	Ack Thermal Shutdown	R	0h	Internal ack for Bit 5 in CHGSTATUS register. Refer to <a href="#">Table 5</a> .
4	Ack Term	R	0h	Internal ack for Bit 4 in CHGSTATUS register. Refer to <a href="#">Table 5</a> .
3	Ack Taper	R	0h	Internal ack for Bit 3 in CHGSTATUS register. Refer to <a href="#">Table 5</a> .
2	Ack Chg	R	0h	Internal ack for Bit 2 in CHGSTATUS register. Refer to <a href="#">Table 5</a> .
1	Ack Prechg	R	0h	Internal ack for Bit 1 in CHGSTATUS register. Refer to <a href="#">Table 5</a> .
0	Ack BattTemp	R	0h	Internal ack for Bit 0 in CHGSTATUS register. Refer to <a href="#">Table 5</a> .

### 7.5.6 ACKINT2 Register (offset: 06h) (reset: 00h)

The ACKINT2 register is internally used to acknowledge any of the interrupts in the corresponding REGSTATUS<7:0> positions. When this is done, the acknowledged interrupt is no longer fed through to the INT pin and so the INT pin becomes free to indicate the next pending interrupt. If none exists, then the INT pin goes high, else it will remain low. A 1 at any position in ACKINT2 is automatically cleared when the corresponding interrupt condition in REGSTATUS is removed. The application processor should not normally need to access the ACKINT2 register.

**Figure 43. ACKINT2 Register**

7	6	5	4	3	2	1	0
Ack PB_ONOFF	Ack BATT_COVER	Ack UVLO	Rsvd	Ack $\overline{\text{PGOOD}}$ LDO2	Ack $\overline{\text{PGOOD}}$ LDO1	Ack $\overline{\text{PGOOD}}$ MAIN	Ack $\overline{\text{PGOOD}}$ CORE
R-0	R-0	R-0	R-0	R-0	R-0	R-0	R-0

LEGEND: R/W = Read/Write; R = Read only; -n = value after reset

**Table 10. ACKINT2 Register Field Descriptions**

BIT	FIELD	TYPE	RESET	DESCRIPTION
7	Ack PB_ONOFF	R	0h	Internal ack for Bit 7 in REGSTATUS register. Refer to <a href="#">Table 6</a> .
6	Ack BATT_COVER	R	0h	Internal ack for Bit 6 in REGSTATUS register. Refer to <a href="#">Table 6</a> .
5	Ack UVLO	R	0h	Internal ack for Bit 5 in REGSTATUS register. Refer to <a href="#">Table 6</a> .
4	Reserved	R	0h	Reserved
3	Ack $\overline{\text{PGOOD}}$ LDO2	R	0h	Internal ack for Bit 3 in REGSTATUS register. Refer to <a href="#">Table 6</a> .
2	Ack $\overline{\text{PGOOD}}$ LDO1	R	0h	Internal ack for Bit 2 in REGSTATUS register. Refer to <a href="#">Table 6</a> .
1	Ack $\overline{\text{PGOOD}}$ MAIN	R	0h	Internal ack for Bit 1 in REGSTATUS register. Refer to <a href="#">Table 6</a> .
0	Ack $\overline{\text{PGOOD}}$ CORE	R	0h	Internal ack for Bit 0 in REGSTATUS register. Refer to <a href="#">Table 6</a> .

### 7.5.7 CHGCONFIG Register (offset: 07h) (reset: 1Bh)

The CHGCONFIG register is used to configure the charger.

**Figure 44. CHGCONFIG Register**

7	6	5	4	3	2	1	0
AUA	Charger reset	Fast charge timer + taper timer enabled	MSB charge current	LSB charge current	USB / 100 mA 500 mA	USB charge allowed	Charge enable
R/W-0	R/W-0	R/W-0	R/W-1	R/W-1	R/W-0	R/W-1	R/W-1

LEGEND: R/W = Read/Write; R = Read only; -n = value after reset

**Table 11. CHGCONFIG Register Field Descriptions**

BIT	FIELD	TYPE	RESET	DESCRIPTION
7	AUA	R/W	0h	0h = If a voltage is present at AC or USB in the appropriate range for charging, and if $V_{CC} > UVLO$ , the TPS65014 is forced into ON mode. The WAIT mode is disabled. 1h = If a voltage source at AC or USB is present, the WAIT mode is enabled, and the TPS65014 does not automatically turn on the converters.
6	Charger reset	R/W	0h	Clears all the timers in the charger and forces a restart of the charge algorithm. 0/1 = This bit must be set and then reset through the serial interface.
5	Fast charge timer + taper timer enabled	R/W	0h	0h = Fast charge timer disabled (default), CHSTATUS <3>= status of the taper detect comparator output. 1h = Enables the fast charge timer and taper timer. CHSTATUS <3>= status of the taper timer.
4	MSB charge current	R/W	1h	Used to set the constant current in the current regulation phase. See <a href="#">Table 12</a> .
3	LSB charge current	R/W	1h	Used to set the constant current in the current regulation phase. See <a href="#">Table 12</a> .
2	USB / 100 mA 500 mA	R/W	0h	0h = Sets the USB charging current to max 100 mA. 1h = Sets the USB charging current to max 500 mA. B2 is ignored if B1 = 0.
1	USB charge allowed	R/W	1h	0h = Prevents any charging from the USB input. 1h = Charging from the USB input is allowed.
0	Charge enable	R/W	1h	0h = Charging is not allowed. 1h = Charger is free to charge from either of the two input sources. If both sources are present and valid, the TPS65014 charges from the AC pin source.

**Table 12. Charge Current Rate**

B4:B3	CHARGE CURRENT RATE
11	Maximum current set by the external resistor at the ISET pin
10	75% of maximum
01	50% of maximum
00	25% of maximum

### 7.5.8 LED1\_ON Register (offset: 08h) (reset: 00h)

The LED1\_ON and LED1\_PER registers can be used to take control of the  $\overline{PG}$  open-drain output normally controlled by the charger.

Figure 45. LED1\_ON Register

7	6	5	4	3	2	1	0
$\overline{PG1}$	LED1 ON6	LED1 ON5	LED1 ON4	LED1 ON3	LED1 ON2	LED1 ON1	LED1 ON0
R/W-0	R/W-0	R/W-0	R/W-0	R/W-0	R/W-0	R/W-0	R/W-0

LEGEND: R/W = Read/Write; R = Read only; -n = value after reset

Table 13. LED1\_ON Register Field Descriptions

BIT	FIELD	TYPE	RESET	DESCRIPTION
7	$\overline{PG1}$	R/W	0h	Control of the $\overline{PG}$ pin is determined by $\overline{PG1}$ and $\overline{PG2}$ according to the table under LED1_PER register
6-0	LED1 ONx	R/W	0h	LED1_ON[6:0] are used to program the on-time of the open-drain output transistor at the $\overline{PG}$ pin. The minimum on-time is typically 10 ms and one LSB corresponds to a 10-ms step change in the on-time.

### 7.5.9 LED1\_PER Register (offset: 09h) (reset: 00h)

Figure 46. LED1\_PER Register

7	6	5	4	3	2	1	0
$\overline{PG2}$	LED1 PER6	LED1 PER5	LED1 PER4	LED1 PER3	LED1 PER2	LED1 PER1	LED1 PER0
R/W-0	R/W-0	R/W-0	R/W-0	R/W-0	R/W-0	R/W-0	R/W-0

LEGEND: R/W = Read/Write; R = Read only; -n = value after reset

Table 14. LED1\_PER Register Field Descriptions

BIT	FIELD	TYPE	RESET	DESCRIPTION
7	$\overline{PG2}$	R/W	0h	Control of the $\overline{PG}$ pin is determined by $\overline{PG1}$ and $\overline{PG2}$ according to <a href="#">Table 15</a> . Default shown in <b>bold</b> .
6-0	LED1 PERx	R/W	0h	LED1_PER<6:0> are used to program the time period of the open-drain output transistor at the $\overline{PG}$ pin. The minimum period is typically 100 ms and one LSB corresponds to a 100-ms, step change in the period.

Table 15. Control of the  $\overline{PG}$  Pin

$\overline{PG1}$	$\overline{PG2}$	BEHAVIOR OF $\overline{PG}$ OPEN-DRAIN OUTPUT
<b>0</b>	<b>0</b>	<b>Under charger control</b>
0	1	Blink
1	0	Off
1	1	Always On

### 7.5.10 LED2\_ON Register (offset: 0Ah) (reset: 00h)

The LED2\_ON and LED2\_PER registers are used to control the LED2 open-drain output.

**Figure 47. LED2\_ON Register**

7	6	5	4	3	2	1	0
LED21	LED2 ON6	LED2 ON5	LED2 ON4	LED2 ON3	LED2 ON2	LED2 ON1	LED2 ON0
R/W-0	R/W-0	R/W-0	R/W-0	R/W-0	R/W-0	R/W-0	R/W-0

LEGEND: R/W = Read/Write; R = Read only; -n = value after reset

**Table 16. LED2\_ON Register Field Descriptions**

BIT	FIELD	TYPE	RESET	DESCRIPTION
7	LED21	R/W	0h	Control is determined by LED21 and LED22 according to <a href="#">Table 18</a> .
6-0	LED2 ONx	R/W	0h	LED2_ON<6:0> are used to program the on-time of the open-drain output transistor at the LED2 pin. The minimum on-time is typically 10 ms and one LSB corresponds to a 10-ms, step change in the on-time.

### 7.5.11 LED2\_PER Register (offset: 0Bh) (reset: 00h)

**Figure 48. LED2\_PER Register**

7	6	5	4	3	2	1	0
LED22	LED2 PER6	LED2 PER5	LED2 PER4	LED2 PER3	LED2 PER2	LED2 PER1	LED2 PER0
R/W-0	R/W-0	R/W-0	R/W-0	R/W-0	R/W-0	R/W-0	R/W-0

LEGEND: R/W = Read/Write; R = Read only; -n = value after reset

**Table 17. LED2\_PER Register Field Descriptions**

BIT	FIELD	TYPE	RESET	DESCRIPTION
7	LED22	R/W	0h	Control is determined by LED21 and LED22 according to <a href="#">Table 18</a> .
6-0	LED2 PERx	R/W	0h	LED2_ON<6:0> are used to program the on-time of the open-drain output transistor at the LED2 pin. The minimum on-time is typically 100 ms and one LSB corresponds to a 100-ms, step change in the on-time.

**Table 18. LED Control**

LED21	LED22	BEHAVIOR OF LED2 OPEN-DRAIN OUTPUT
0	0	Off
0	1	Blink
1	0	Off
1	1	Always On

### 7.5.12 VDCDC1 Register (offset: 0Ch) (reset: 32h/33h)

The VDCDC1 register is used to program the VMAIN switching converter.

**Figure 49. VDCDC1 Register**

7	6	5	4	3	2	1	0
FPWM	UVLO1	UVLO0	ENABLE SUPPLY	ENABLE LP	MAIN DISCHARGE	MAIN1	MAIN0
R/W-0	R/W-0	R/W-0	R/W-0	R/W-0	R/W-0	R/W-0	R/W-0

LEGEND: R/W = Read/Write; R = Read only; -n = value after reset

**Table 19. VDCDC1 Register Field Descriptions**

BIT	FIELD	TYPE	RESET	DESCRIPTION
7	FPWM	R/W	0h	Forced PWM mode for DC-DC converters. 0h = MAIN and the CORE DC-DC converter are allowed to switch into PFM mode. 1h = MAIN and the CORE DC-DC converter operate with forced fixed-frequency PWM mode and are not allowed to switch into PFM mode, at light load.
6-5	UVLOx	R/W	0h	The undervoltage threshold voltage is set by UVLO1 and UVLO0 according to <a href="#">Table 20</a> , with the default value in <b>bold</b> .
4	ENABLE SUPPLY	R/W	1h	Selects between LOW POWER mode and WAIT mode 0h = WAIT mode allowed, activated when LOW_PWR pin = 1 and VDCDC1 <3>= 1. 1h = The TPS65014 enters LOW POWER mode when LOW_PWR pin = 1 and VDCDC1 <3>= 1
3	ENABLE LP	R/W	0h	0h = Disables the low power function of the LOW_PWR pin 1h = Enables the low power function of the LOW_PWR pin.
2	MAIN DISCHARGE	R/W	0h	0h = disables the active discharge of the VMAIN converter output. 1h = enables the active discharge of the VMAIN converter output, when the converter is disabled (that is, in WAIT mode).
1-0	MAINx	R/W	1h	The VMAIN converter output voltages are set according to <a href="#">Table 21</a> , with the default values in bold set by the DEFMAIN pin. The default voltage can subsequently be overwritten through the serial interface after start-up.

**Table 20. Undervoltage Threshold Voltage**

UVLO1	UVLO0	V <sub>UVLO</sub>
0	0	2.5 V
0	1	2.75 V
1	0	3.0 V
1	1	3.25 V

**Table 21. VMAIN Converter Output Voltage**

MAIN1	MAIN0	VMAIN
0	0	2.5 V
0	1	2.75 V
1	0	3.0 V
1	1	3.3 V

### 7.5.13 VDCDC2 Register (offset: 0Dh) (reset: 60h/70h)

The VDCDC2 register is used to program the V<sub>CORE</sub> switching converter output voltage. It is programmable in 8 steps between 0.85 V and 1.8 V. The default value is governed by the DEFCORE pin; DEFCORE=0 sets an output voltage of 1.5 V. DEFCORE=1 sets an output voltage of 1.8 V.

**Figure 50. VDCDC2 Register**

7	6	5	4	3	2	1	0
LP_COREOFF	CORE2	CORE1	CORE0	CORELP1	CORELP0	VIB	CORE DISCHARGE
R/W-0	R/W-1	R/W-1	R/W- DEFCORE	R/W-1	R/W-0	R/W-0	R/W-0

LEGEND: R/W = Read/Write; R = Read only; -n = value after reset

**Table 22. VDCDC2 Register Field Descriptions**

BIT	FIELD	TYPE	RESET	DESCRIPTION
7	LP_COREOFF	R/W	0h	0h = V <sub>CORE</sub> converter is enabled in low power mode. 1h = V <sub>CORE</sub> converter is disabled in low power mode.
6-5	COREx	R/W	1h	<a href="#">Table 23</a> shows all possible values of V <sub>CORE</sub> . The default value can subsequently be overwritten through the serial interface after start-up.
4	CORE0	R/W	DEFCORE	<a href="#">Table 23</a> shows all possible values of V <sub>CORE</sub> . The default value can subsequently be overwritten through the serial interface after start-up.
3	CORELP1	R/W	1h	CORELP1 and CORELP0 can be used to set the V <sub>CORE</sub> voltage in low power mode. In low power mode, CORE2 is effectively 0, and CORE1, CORE0 take on the values programmed at CORELP1 and CORELP0, default 10 giving V <sub>CORE</sub> = 1.1 V as default in low power mode. When low power mode is exited, V <sub>CORE</sub> reverts to the value set by CORE2, CORE1, and CORE0.
2	CORELP0	R/W	0h	CORELP1 and CORELP0 can be used to set the V <sub>CORE</sub> voltage in low power mode. In low power mode, CORE2 is effectively 0, and CORE1, CORE0 take on the values programmed at CORELP1 and CORELP0, default 10 giving V <sub>CORE</sub> = 1.1 V as default in low power mode. When low power mode is exited, V <sub>CORE</sub> reverts to the value set by CORE2, CORE1, and CORE0.
1	VIB	R/W	0h	0h = Disables the VIB output transistor 1h = Enables the VIB output transistor to drive the vibrator motor.
0	CORE DISCHARGE	R/W	0h	0h = Disables the active discharge of the V <sub>CORE</sub> converter output. 1h = Enables the active discharge of the V <sub>CORE</sub> converter output in WAIT mode, or if VDCDC2 <7>= 1 in LOW POWER mode.

**Table 23. V<sub>CORE</sub> Values**

CORE2	CORE1	CORE0	V <sub>CORE</sub>
0	0	0	0.85 V
0	0	1	1.0 V
0	1	0	1.1 V
0	1	1	1.2 V
1	0	0	1.3 V
1	0	1	1.4 V
1	1	0	1.5 V
1	1	1	1.8 V

**7.5.14 VREGS1 Register (offset: 0Eh) (reset: 88h)**

The VREGS1 register is used to program and enable LDO1 and LDO2 and to set their behavior when low power mode is active. The LDO output voltages can be set either on the fly, while the relevant LDO is disabled, or simultaneously when the relevant enable bit is set. Note that both LDOs are per default ON.

**Figure 51. VREGS1 Register**

7	6	5	4	3	2	1	0
LDO2 enable	LDO2 OFF/ nSLP	LDO21	LDO20	LDO1 enable	LDO1 OFF/ nSLP	LDO11	LDO10
R/W-0	R/W-0	R/W-0	R/W-0	R/W-0	R/W-0	R/W-0	R/W-0

LEGEND: R/W = Read/Write; R = Read only; -n = value after reset

**Table 24. VREGS1 Register Field Descriptions**

BIT	FIELD	TYPE	RESET	DESCRIPTION
7	LDO2 enable	R/W	1h	The function of the LDO2 enable and LDO2 OFF/nSLP bits is shown in <a href="#">Table 25</a> . See the power-on sequencing section for details of low power mode.
6	LDO2 OFF / nSLP	R/W	0h	The function of the LDO2 enable and LDO2 OFF/nSLP bits is shown in <a href="#">Table 25</a> . See the power-on sequencing section for details of low power mode.
5-4	LDO2x	R/W	0h	LDO2 has a default output voltage of 1.8 V. If desired, this can be changed at the same time as it is enabled through the serial interface. See <a href="#">Table 26</a> .
3	LDO1 enable	R/W	1h	The function of the LDO1 enable and LDO1 OFF/nSLP bits is shown in <a href="#">Table 27</a> . See the power-on sequencing section for details of low-power mode. Note that programming LDO1 to a higher voltage may force a system power-on reset if the increase is in the 10% or greater range.
2	LDO1 OFF / nSLP	R/W	0h	The function of the LDO1 enable and LDO1 OFF/nSLP bits is shown in <a href="#">Table 27</a> . See the power-on sequencing section for details of low-power mode. Note that programming LDO1 to a higher voltage may force a system power-on reset if the increase is in the 10% or greater range.
1-0	LDO1x	R/W	0h	The LDO1 output voltage is per default set externally. If so desired, this can be changed through the serial interface. See <a href="#">Table 28</a> .

**Table 25. LDO2 Enable and LDO2 OFF/nSLP Functions**

LDO2 ENABLE	LDO2 OFF / nSLP	LDO STATUS IN NORMAL MODE	LDO STATUS IN LOW-POWER MODE
0	X	OFF	OFF
1	0	ON, full power	ON, reduced power and performance
1	1	ON, full power	OFF

**Table 26. LDO21/LDO20**

LDO21	LDO20	VLDO2
0	0	1.8 V
0	1	2.5 V
1	0	3.0 V
1	1	3.3 V

**Table 27. LDO1 Enable and LDO1 OFF/nSLP Functions**

LDO1 ENABLE	LDO1 OFF / nSLP	LDO STATUS IN NORMAL MODE	LDO STATUS IN LOW-POWER MODE
0	X	OFF	OFF
1	0	ON, full power	ON, reduced power and performance
1	1	ON, full power	OFF

**Table 28. LDO11/LDO10**

LDO11	LDO10	VLDO1
0	0	ADJ
0	1	2.5 V
1	0	2.75 V
1	1	3.0 V

### 7.5.15 MASK3 Register (offset: 0Fh) (reset: 00h)

The MASK3 register must be considered when any of the GPIO pins are programmed as inputs.

**Figure 52. MASK3 Register**

7	6	5	4	3	2	1	0
Edge trigger GPIO4	Edge trigger GPIO3	Edge trigger GPIO2	Edge trigger GPIO1	Mask GPIO4	Mask GPIO3	Mask GPIO2	Mask GPIO1
R/W-0	R/W-0	R/W-0	R/W-0	R/W-0	R/W-0	R/W-0	R/W-0

LEGEND: R/W = Read/Write; R = Read only; -n = value after reset

**Table 29. MASK3 Register Field Descriptions**

BIT	FIELD	TYPE	RESET	DESCRIPTION
7-4	Edge trigger GPIOx	R/W	0h	Determines whether the respective GPIO generates an interrupt at a rising or a falling edge. 0h = Falling edge triggered. 1h = Rising edge triggered.
3-0	Mask GPIOx	R/W	0h	Used to mask the corresponding interrupt. Default is unmasked (mask GPIOx = 0).

### 7.5.16 DEFGPIO Register (offset = 10h) (reset: 00h)

The DEFGPIO register is used to define the GPIO pins to be either input or output.

**Figure 53. DEFGPIO Register**

7	6	5	4	3	2	1	0
IO4	IO3	IO2	IO1	Value GPIO4	Value GPIO3	Value GPIO2	Value GPIO1
R/W-0	R/W-0	R/W-0	R/W-0	R/W-0	R/W-0	R/W-0	R/W-0

LEGEND: R/W = Read/Write; R = Read only; -n = value after reset

**Table 30. DEFGPIO Register Field Descriptions**

BIT	FIELD	TYPE	RESET	DESCRIPTION
7-4	IOx	R/W	0h	0h = Sets the corresponding GPIO to be an input. 1h = Sets the corresponding GPIO to be an output.
3-0	Value GPIOx	R/W	0h	If a GPIO is programmed to be an output, then the signal output is determined by the corresponding bit. The output circuit for each GPIO is an open-drain NMOS requiring an external pullup resistor. 1h = Activates the relevant NMOS, hence forcing a logic low signal at the GPIO pin. 0h = Turns the open-drain transistor OFF, hence the voltage at the GPIO pin is determined by the voltage to which the pullup resistor is connected. If a particular GPIO is programmed to be an input, then the contents of the relevant bit in B3-0 is defined by the logic level at the GPIO pin. A logic low forces a 0 and a logic high forces a 1. If a GPIO is programmed to be an input, then any attempt to write to the relevant bit in B3-0 is ignored.

## 8 Application and Implementation

---

### NOTE

Information in the following applications sections is not part of the TI component specification, and TI does not warrant its accuracy or completeness. TI's customers are responsible for determining suitability of components for their purposes. Customers should validate and test their design implementation to confirm system functionality.

---

### 8.1 Application Information

The TPS65014 is an integrated power- and battery-management IC designed to pair with various application processors powered by one Li-ion or Li-polymer cell and which require multiple rails.

### 8.2 Typical Application

The VCORE and VMAIN converter are always enabled in a typical application. The VCORE output voltage can be disabled or reduced from 1.5 V to a lower, preset voltage under processor control. When the processor enters the sleep mode, a high signal on the LOW\_PWR pin initiates the change.

VCORE typically supplies the digital part of the audio codec. When the processor is in sleep or low-power mode, the audio codec is powered off, so the VCORE voltage can be programmed to lower voltages without a problem. A typical audio codec (such as the TI AIC23) consumes about 20-mA to 30-mA current from the VCORE power supply.

Supply LDO1 from VMAIN as shown in [Figure 54](#). If this is not done, then subsequent to a UVLO, OVERTEMP, or BATT\_COVER = 0 condition, the RESPWRON signal goes high before the VCORE rail has ramped and stabilized. Therefore, the processor core does not receive a power-on-reset signal.

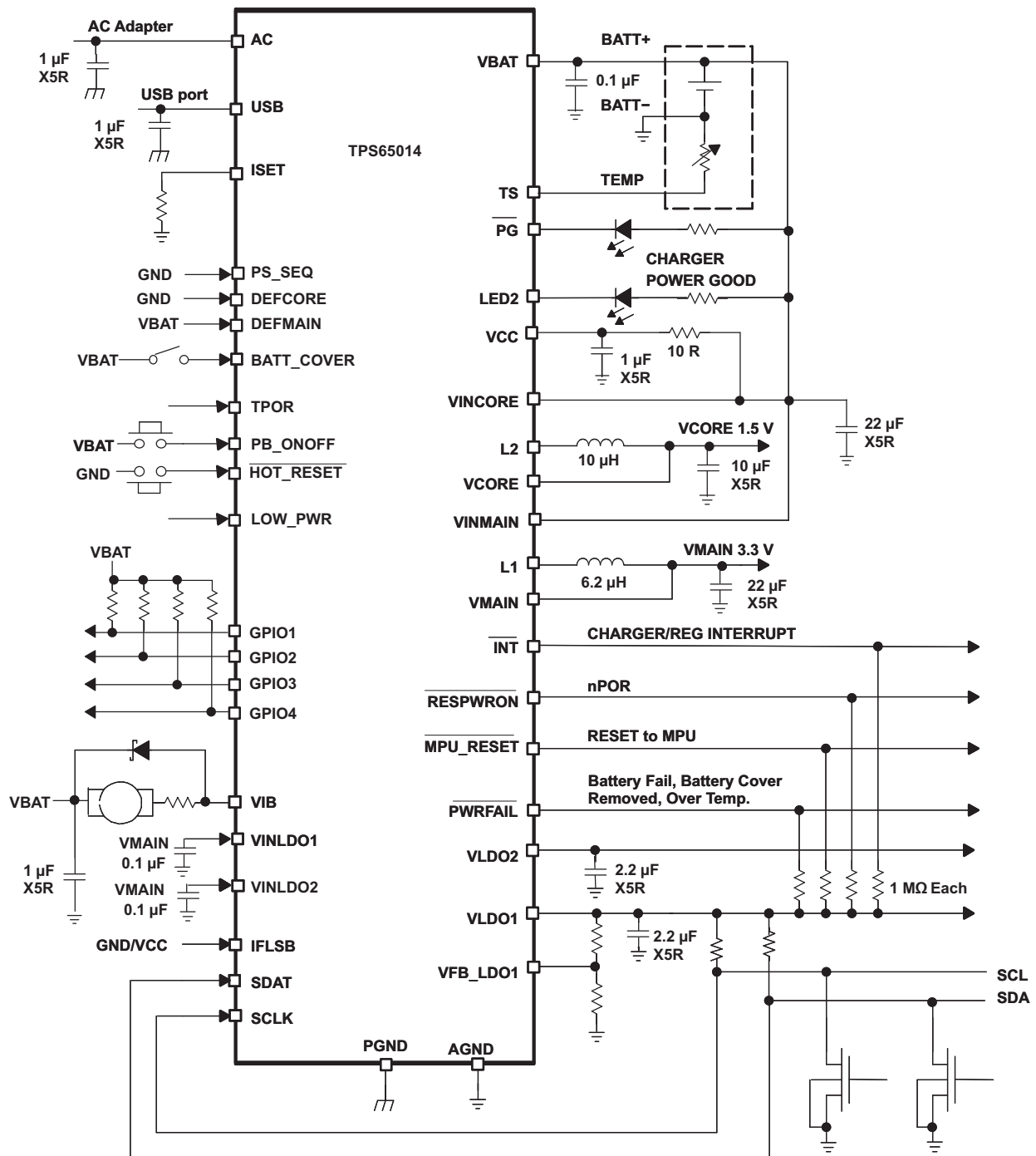
**Typical Application (continued)**

**Figure 54. Typical Application Circuit**

Typical Application (continued)

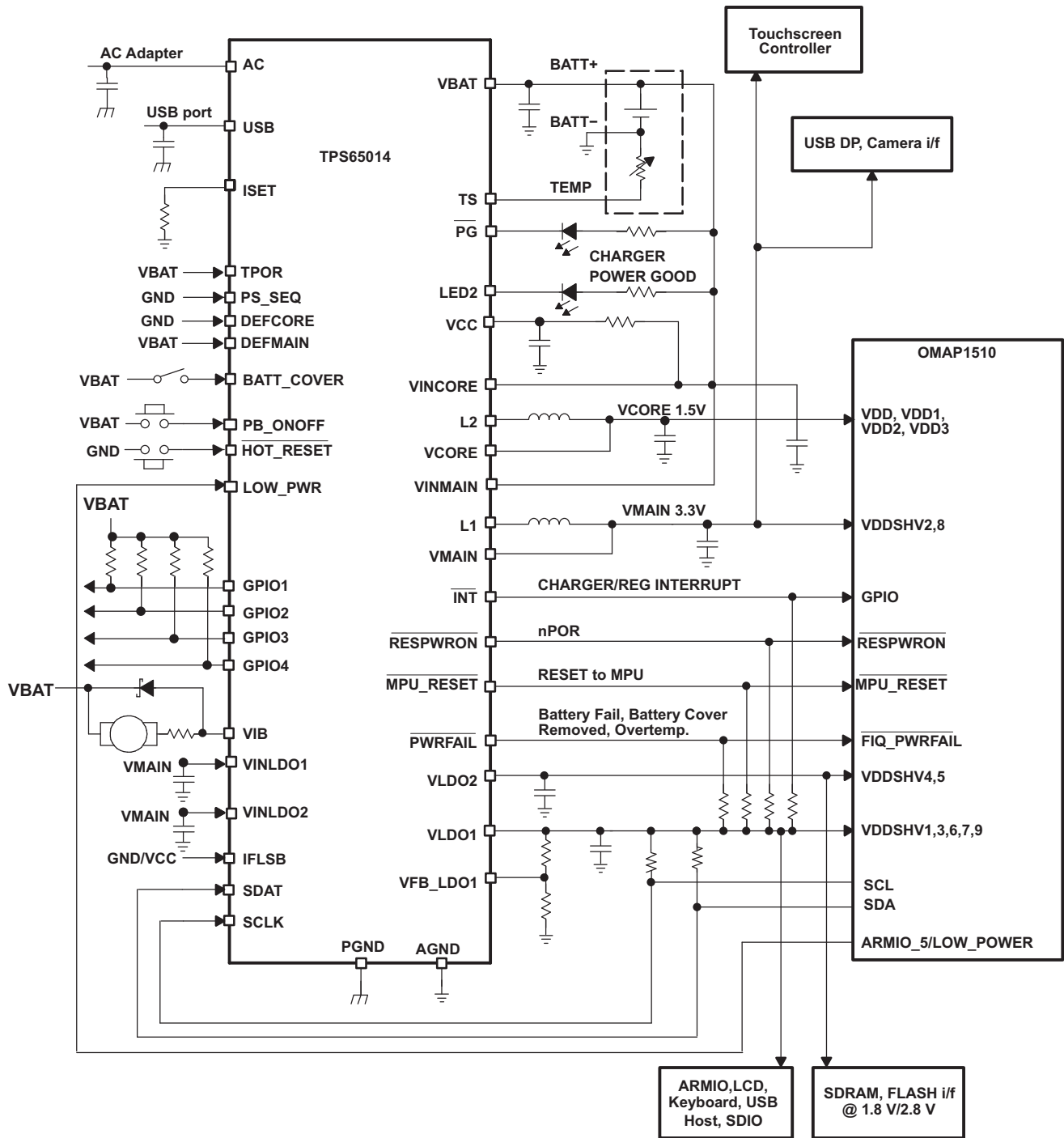

Figure 55. Typical Application Circuit in Low-Power Mode

8.2.1 Design Requirements

Each DC-DC converter requires an external inductor and filter capacitor, capable of sustaining the intended current with an acceptable voltage ripple. LDOs must have external filter capacitors, and LDO1 requires an external feedback network for regulation. Every input supply rail requires a decoupling capacitor close to the pin. To avoid unintended states, logic inputs without internal resistors must not be left floating.

## Typical Application (continued)

### 8.2.2 Detailed Design Procedure

#### 8.2.2.1 Inductor Selection for the Main and the Core Converter

The main and the core converters in the TPS65014 typically use a 6.2- $\mu\text{H}$  and a 10- $\mu\text{H}$  output inductor, respectively. Larger or smaller inductor values can be used to optimize the performance of the device for specific operation conditions. The selected inductor must be rated for its DC resistance and saturation current. The DC resistance of the inductance influences directly the efficiency of the converter. Therefore, an inductor with lowest DC resistance is selected for highest efficiency.

Equation 3 calculates the maximum inductor current under static load conditions. The saturation current of the inductor must be rated higher than the maximum inductor current as calculated with Equation 3. This is necessary because during heavy load transient, the inductor current rises above the value calculated in Equation 4.

$$\Delta I_L = V_O \times \frac{1 - \frac{V_O}{V_I}}{L \times f} \quad (3)$$

$$I_{L(\max)} = I_{O(\max)} + \frac{\Delta I_L}{2}$$

where

- $f$  = Switching frequency (1.25-MHz typical)
  - $L$  = Inductor value
  - $\Delta I_L$  = Peak-to-peak inductor ripple current
  - $I_{L\max}$  = Maximum inductor current
- (4)

The highest inductor current occurs at maximum  $V_I$ .

Open core inductors have a soft saturation characteristic, and they can usually handle higher inductor currents versus a comparable shielded inductor.

A more conservative approach is to select the inductor current rating just for the maximum switch current of the TPS65014 (2 A for the main converter and 0.8 A for the core converter). The core material from inductor to inductor differs and has an impact on the efficiency, especially at high switching frequencies.

See Table 31 and the typical applications for possible inductors

**Table 31. Tested Inductors**

DEVICE	INDUCTOR VALUE	DIMENSIONS	COMPONENT SUPPLIER
Core converter	10 $\mu\text{H}$	6 mm $\times$ 6 mm $\times$ 2 mm	Sumida CDRH5D18-100
	10 $\mu\text{H}$	5 mm $\times$ 5 mm $\times$ 3 mm	Sumida CDRH4D28-100
Main converter	4.7 $\mu\text{H}$	5.5 mm $\times$ 6.6 mm $\times$ 1 mm	Coilcraft LPO1704-472M
	4.7 $\mu\text{H}$	5 mm $\times$ 5 mm $\times$ 3 mm	Sumida CDRH4D28C-4.7
	4.7 $\mu\text{H}$	5.2 mm $\times$ 5.2 mm $\times$ 2.5 mm	Coiltronics SD25-4R7
	5.3 $\mu\text{H}$	5.7 mm $\times$ 5.7 mm $\times$ 3 mm	Sumida CDRH5D28-5R3
	6.2 $\mu\text{H}$	5.7 mm $\times$ 5.7 mm $\times$ 3 mm	Sumida CDRH5D28-6R2
	6 $\mu\text{H}$	7 mm $\times$ 7 mm $\times$ 3 mm	Sumida CDRH6D28-6R0

#### 8.2.2.2 Output Capacitor Selection

The advanced fast response voltage-mode control scheme of the inductive converters implemented in the TPS65014 allows the use of small ceramic capacitors with a typical value of 22  $\mu\text{F}$  for the main converter and 10  $\mu\text{F}$  for the core converter, without having large output voltage undershoots and overshoots during heavy load transients. TI recommends ceramic capacitors with low ESR values and the lowest output voltage ripple. If required, tantalum capacitors with an ESR  $<$  100  $\Omega$  may be used as well.

See Table 32 for recommended components.

If ceramic output capacitors are used, the capacitor RMS ripple current rating always meet the application requirements. For completeness, the RMS ripple current is calculated as in Equation 5:

$$I_{\text{RMSC(out)}} = V_O \times \frac{1 - \frac{V_O}{V_I}}{L \times f} \times \frac{1}{2 \times \sqrt{3}} \tag{5}$$

At nominal load current, the inductive converters operate in PWM mode, and the overall output voltage ripple is the sum of the voltage spike caused by the output capacitor ESR plus the voltage ripple caused by charging and discharging the output capacitor, as in Equation 6:

$$\Delta V_O = V_O \times \frac{1 - \frac{V_O}{V_I}}{L \times f} \times \left( \frac{1}{8 \times C_O \times f} + \text{ESR} \right) \tag{6}$$

Where the highest output voltage ripple occurs at the highest input voltage  $V_I$ .

At light load currents, the converters operate in power save mode and the output voltage ripple is independent of the output capacitor value. The output voltage ripple is set by the internal comparator thresholds. The typical output voltage ripple is 1% of the nominal output voltage. If the output voltage for the core converter is programmed to its lowest voltage of 0.85 V, the output capacitor must be increased to 22  $\mu\text{F}$  for low output voltage ripple. This is because the current in the inductor decreases slowly during the off-time and further increases the output voltage, even when the PMOS is off. This effect increases with low output voltages.

**8.2.2.3 Input Capacitor Selection**

A pulsating input current is the nature of the buck converter. Therefore, a low ESR input capacitor is required for best input voltage filtering. It also minimizes the interference with other circuits caused by high input voltage spikes. The main converter requires a 22- $\mu\text{F}$  ceramic input capacitor, and the core converter requires a 10- $\mu\text{F}$  ceramic capacitor. The input capacitor for the main and the core converter can be combined and one 22- $\mu\text{F}$  capacitor can be used instead, because the two converters operate with a phase shift of 270 degrees. The input capacitor can be increased without any limit for better input voltage filtering. The VCC pin should be separated from the input for the main and the core converter. A filter resistor of up to 100  $\Omega$  and a 1- $\mu\text{F}$  capacitor is used for decoupling the VCC pin from switching noise.

**Table 32. Possible Capacitors**

CAPACITOR VALUE	CASE SIZE	COMPONENT SUPPLIER	COMMENTS
22 $\mu\text{F}$	1206	TDK C3216X5R0J226M	Ceramic
22 $\mu\text{F}$	1206	Taiyo Yuden JMK316BJ226ML	Ceramic
22 $\mu\text{F}$	1210	Taiyo Yuden JMK325BJ226MM	Ceramic

**8.2.3 Application Curves**

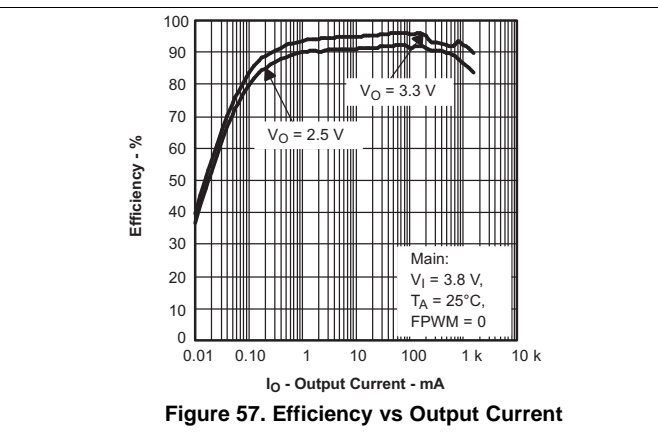
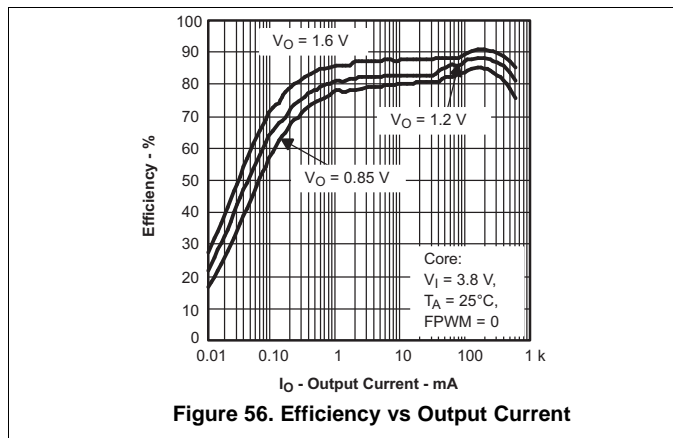

## 9 Power Supply Recommendations

### 9.1 Battery Charger

The TPS65014 supports a precision Li-ion or Li-polymer charging system suitable for single cells with either coke or graphite anodes. Charging the battery is possible even without the application processor being powered up. The TPS65014 starts charging when an input voltage on either AC or USB input is present, which is greater than the charger UVLO threshold. See [Figure 58](#) for a typical charge profile.



**Figure 58. Typical Charging Profile**

#### 9.1.1 Autonomous Power Source Selection

By default, the TPS65014 attempts to charge from the AC input. If AC input is not present, USB is selected. If both inputs are available, the AC input has priority. The charge current is initially limited to 100 mA when charging from the USB input. This can be increased to 500 mA through the serial interface. The charger can be completely disabled through the interface or from the USB port. The start of the charging process from the USB port is delayed to allow the application processor time to disable USB charging, for instance if a USB OTG port is recognized. The recommended input voltage for charging from the AC input is  $4.5\text{ V} < V_{AC} < 6.5\text{ V}$ . However, the TPS65014 is capable of withstanding (but not charging from) up to 20 V. Charging is disabled if  $V_{AC}$  is greater than typically 7 V.

#### 9.1.2 Temperature Qualification

The TPS65014 continuously monitors battery temperature by measuring the voltage between the TS and AGND pins. An internal current source provides the bias for most common 10K negative-temperature coefficient thermistors (NTC) (see [Figure 59](#)). The IC compares the voltage on the TS pin against the internal  $V_{(LTF)}$  and  $V_{(HTF)}$  thresholds to determine if charging is allowed. Once a temperature outside the  $V_{(LTF)}$  and  $V_{(HTF)}$  thresholds is detected, the IC immediately suspends the charge. The IC suspends charge by turning off the power FET and holding the timer value (that is, timers are *not* reset). Charge is resumed when the temperature returns to the normal range.

The allowed temperature range for a 103-A T-type thermistor is  $0^{\circ}\text{C}$  to  $+45^{\circ}\text{C}$ . However, the user may modify these thresholds by adding two external resistors (see [Figure 60](#)).

## Battery Charger (continued)

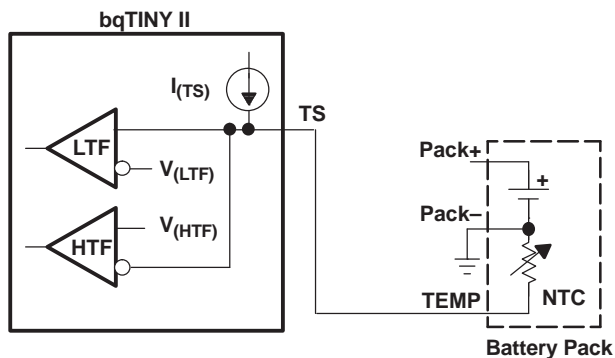

Figure 59. TS Pin Configuration

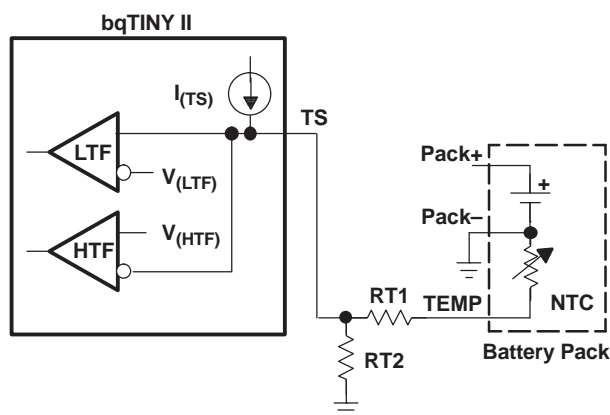

Figure 60. TS Pin Threshold

### 9.1.3 Battery Preconditioning

On power up, if the battery voltage is below the  $V_{(LOWV)}$  threshold, the TPS65014 applies a precharge current,  $I_{(PRECHG)}$ , to the battery. This feature revives deeply discharged cells. The charge current during this phase is one tenth of the value in current regulation phase, which is set with  $I_{O(out)} = KSET \times V_{(SET)} / R_{(SET)}$ . The load current in the preconditioning phase must be lower than  $I_{(PRECHG)}$  and must allow the battery voltage to rise above  $V_{(LOWV)}$  within  $t_{(Prechg)}$ . VBAT\_A is the sense pin to the voltage comparator for the battery voltage. This allows a power-on sense measurement if the VBAT\_A and VBAT\_B pins are connected together at the battery.

The TPS65014 activates a safety timer,  $t_{(PRECHG)}$ , during the conditioning phase. If  $V_{(LOWV)}$  threshold is not reached within the timer period, the TPS65014 turns off the charger and indicates the fault condition in the CHGSTATUS register. In the case of a fault condition, the TPS65014 reduces the current to  $I_{(DETECT)}$ .  $I_{(DETECT)}$  is used to detect a battery replacement condition. Fault condition is cleared by POR or battery replacement or through the serial interface.

### 9.1.4 Battery Charge Current

The TPS65014 offers on-chip current regulation. When charging from an AC adapter, a resistor connected between the ISET1 and AGND pins determines the charge rate. A maximum of 1-A charger current from the AC adapter is allowed. When charging from a USB port, either a 100-mA or 500-mA charge rate can be selected through the serial interface; default is 100-mA maximum. Two bits are available in the CHGCONFIG register in the serial interface to reduce the charge current in 25% steps. These only influence charging from the AC input, and may be of use if charging is often suspended due to excessive junction temperature in the TPS65014 (such as at high AC input voltages) and low battery voltages.

## Battery Charger (continued)

### 9.1.5 Battery Voltage Regulation

The voltage regulation feedback is through the VBAT pin. This pin is tied directly to the positive side of the battery pack. The TPS65014 monitors the battery-pack voltage between the VBAT and AGND pins. The TPS65014 is offered in a fixed-voltage version of 4.2 V.

As a safety backup, the TPS65014 also monitors the charge time in the fast-charge mode. If taper current is not detected within this time period,  $t_{(CHG)}$ , the TPS65014 turns off the charger and indicates FAULT in the CHGSTATUS register. In the case of a FAULT condition, the TPS65014 reduces the current to  $I_{(DETECT)}$ .  $I_{(DETECT)}$  is used to detect a battery replacement condition. Fault condition is cleared by POR through the serial interface. The safety timer is reset if the TPS65014 is forced out of the voltage regulation mode. The fast-charge timer is disabled by default to allow charging during normal operation of the end equipment. It is enabled through the CHGCONFIG register.

### 9.1.6 Charge Termination and Recharge

The TPS65014 monitors the charging current during the voltage regulation phase. Once the taper threshold,  $I_{(TAPER)}$ , is detected, the TPS65014 initiates the taper timer,  $t_{(TAPER)}$ . Charge is terminated after the timer expires. The TPS65014 resets the taper timer in the event that the charge current returns above the taper threshold,  $I_{(TAPER)}$ . After a charge termination, the TPS65014 restarts the charge once the voltage on the VBAT pin falls below the  $V_{(RCH)}$  threshold. This feature keeps the battery at full capacity at all times. The fast charge timer and the taper timer must be enabled by programming CHGCONFIG(5)=1. A thermal suspend suspends the fast-charge and taper timers.

In addition to the taper current detection, the TPS65014 terminates charge in the event that the charge current falls below the  $I_{(TERM)}$  threshold. This feature allows for quick recognition of a battery removal condition. When a full battery is replaced with an empty battery, the TPS65014 detects that the VBAT voltage is below the recharge threshold and starts charging the new battery. The taper and termination bits are cleared in the CHGSTATUS register and if the  $\overline{INT}$  pin is still active due to these two interrupt sources, then it is de-asserted. Depending on the transient seen at the VCC pin, all registers may be set to their default values and require reprogramming with any nondefault values required, such as enabling the fast-charge timer and taper termination; this should only happen if VCC drops below approximately 2 V.

### 9.1.7 $\overline{PG}$ Output

The open-drain, power-good ( $\overline{PG}$ ) output indicates when a valid power supply is present for the charger. This can be either from the AC adapter input or from the USB. The output turns ON when a valid voltage is detected. A valid voltage is detected whenever the voltage on either pin AC or pin USB rises above the voltage on VBAT plus 100 mV. This output is turned off in the sleep mode. The  $\overline{PG}$  pin can be used to drive an LED or communicate to the host processor. A voltage greater than the  $V_{(CHGOVLO)}$  threshold (typ 7-V) at the AC input is not valid and does not activate the  $\overline{PG}$  output. The  $\overline{PG}$  output is held in high impedance state if the charger is in reset by programming CHGCONFIG(6)=1.

The  $\overline{PG}$  output can also be programmed through the LED1\_ON and LED1\_PER registers in the serial interface. It can then be programmed to be permanently on, off, or to blink with defined on- and period-times.  $\overline{PG}$  is controlled by default through the charger.

### 9.1.8 Thermal Considerations for Setting Charge Current

The TPS65014 is housed in a 48-pin QFN package with exposed leadframe on the underside. This 7-mm x 7-mm package exhibits a thermal impedance (junction-to-ambient) of 33 K/W when mounted on a JEDEC high-k board with zero air flow. Refer to [Table 33](#) for maximum charge current considerations.

**Table 33. Power Dissipation Limitations**

AMBIENT TEMPERATURE	MAX POWER DISSIPATION FOR $T_j = 125^\circ\text{C}$
25°C	3 W
55°C	2.1 W
Above 55°C	30 mW/°C

Consideration must be given to the maximum charge current when the assembled application board exhibits a thermal impedance, which differs significantly from the JEDEC high-k board. The charger has a thermal shutdown feature, which suspends charging if the TPS65014 junction temperature rises above a threshold of 145°C. This threshold is set 15°C below the threshold used to power down the TPS65014 completely.

## 9.2 LDO1 Output Voltage Adjustment

The output voltage of LDO1 is set with a resistor divider at the feedback pin. The sum of the two resistors must not exceed 1 MΩ to minimize voltage changes due to leakage current into the feedback pin. The output voltage for LDO1 after start-up is the voltage set by the external resistor divider. It can be reprogrammed with the I<sup>2</sup>C interface to the three other values defined in the register VREGS1.

# 10 Layout

## 10.1 Layout Guidelines

- The input capacitors for the DC-DC converters must be placed as close as possible to the VINMAIN, VINCORE, and VCC pins.
- The inductor of the output filter must be placed as close as possible to the device to provide the shortest switch node possible, thus reducing the noise emitted into the system and increasing the efficiency.
- Sense the feedback voltage from the output at the output capacitors to ensure the best DC accuracy. Feedback must be routed away from noisy sources such as the inductor. If possible, route on the opposite side from the switch node and inductor, and place a GND plane between the feedback and the noisy sources or keepout underneath them entirely.
- Place the output capacitors as close as possible to the inductor to reduce the feedback loop. This ensures best regulation at the feedback point.
- Place the device as close as possible to the most demanding or sensitive load. The output capacitors must be placed close to the input of the load, which ensures the best AC performance possible.
- The input and output capacitors for the LDOs must be placed close to the device for best regulation performance.
- Use vias to connect the thermal pad to the ground plane.
- TI recommends using the common ground plane for the layout of this device. The AGND can be separated from the PGND, but a large low-parasitic PGND is required to connect the PGNDx pins to the CIN and external PGND connections. If the AGND and PGND planes are separated, have one connection point to reference the grounds together. Place this connection point close to the IC.

## 10.2 Layout Example

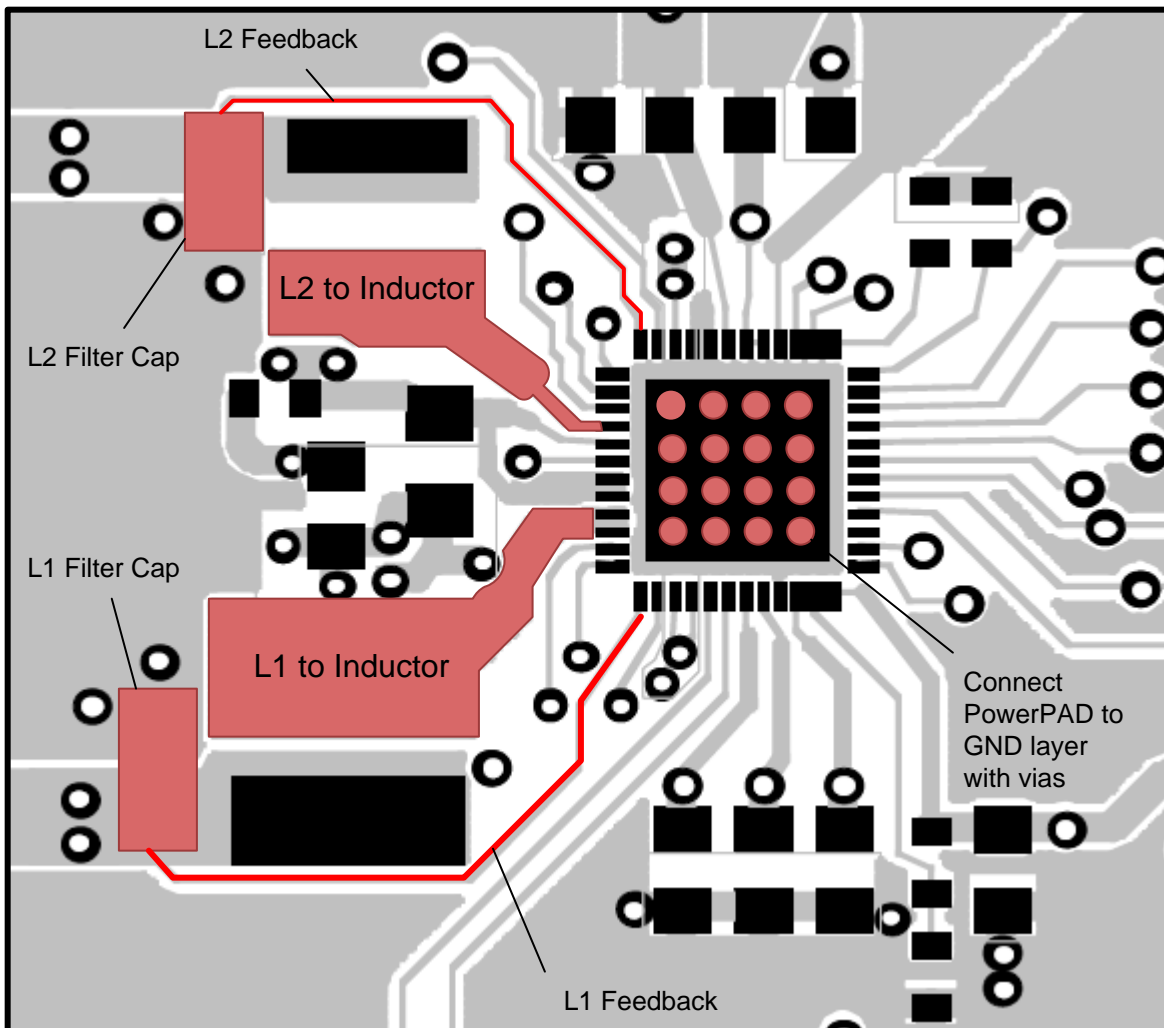

Figure 61. Layout Recommendation

## 11 Device and Documentation Support

### 11.1 Device Support

#### 11.1.1 Third-Party Products Disclaimer

TI'S PUBLICATION OF INFORMATION REGARDING THIRD-PARTY PRODUCTS OR SERVICES DOES NOT CONSTITUTE AN ENDORSEMENT REGARDING THE SUITABILITY OF SUCH PRODUCTS OR SERVICES OR A WARRANTY, REPRESENTATION OR ENDORSEMENT OF SUCH PRODUCTS OR SERVICES, EITHER ALONE OR IN COMBINATION WITH ANY TI PRODUCT OR SERVICE.

### 11.2 Community Resources

The following links connect to TI community resources. Linked contents are provided "AS IS" by the respective contributors. They do not constitute TI specifications and do not necessarily reflect TI's views; see TI's [Terms of Use](#).

**TI E2E™ Online Community** *TI's Engineer-to-Engineer (E2E) Community*. Created to foster collaboration among engineers. At [e2e.ti.com](http://e2e.ti.com), you can ask questions, share knowledge, explore ideas and help solve problems with fellow engineers.

**Design Support** *TI's Design Support* Quickly find helpful E2E forums along with design support tools and contact information for technical support.

### 11.3 Trademarks

E2E is a trademark of Texas Instruments.  
All other trademarks are the property of their respective owners.

### 11.4 Electrostatic Discharge Caution



These devices have limited built-in ESD protection. The leads should be shorted together or the device placed in conductive foam during storage or handling to prevent electrostatic damage to the MOS gates.

### 11.5 Glossary

[SLYZ022](#) — *TI Glossary*.

This glossary lists and explains terms, acronyms, and definitions.

## 12 Mechanical, Packaging, and Orderable Information

The following pages include mechanical, packaging, and orderable information. This information is the most current data available for the designated devices. This data is subject to change without notice and revision of this document. For browser-based versions of this data sheet, refer to the left-hand navigation.

**PACKAGING INFORMATION**

Orderable Device	Status (1)	Package Type	Package Drawing	Pins	Package Qty	Eco Plan (2)	Lead finish/ Ball material (6)	MSL Peak Temp (3)	Op Temp (°C)	Device Marking (4/5)	Samples
TPS65014RGZT	ACTIVE	VQFN	RGZ	48	250	RoHS & Green	NIPDAU	Level-2-260C-1 YEAR	-40 to 85	TPS65014	Samples

(1) The marketing status values are defined as follows:

**ACTIVE:** Product device recommended for new designs.

**LIFEBUY:** TI has announced that the device will be discontinued, and a lifetime-buy period is in effect.

**NRND:** Not recommended for new designs. Device is in production to support existing customers, but TI does not recommend using this part in a new design.

**PREVIEW:** Device has been announced but is not in production. Samples may or may not be available.

**OBSOLETE:** TI has discontinued the production of the device.

(2) **RoHS:** TI defines "RoHS" to mean semiconductor products that are compliant with the current EU RoHS requirements for all 10 RoHS substances, including the requirement that RoHS substance do not exceed 0.1% by weight in homogeneous materials. Where designed to be soldered at high temperatures, "RoHS" products are suitable for use in specified lead-free processes. TI may reference these types of products as "Pb-Free".

**RoHS Exempt:** TI defines "RoHS Exempt" to mean products that contain lead but are compliant with EU RoHS pursuant to a specific EU RoHS exemption.

**Green:** TI defines "Green" to mean the content of Chlorine (Cl) and Bromine (Br) based flame retardants meet JS709B low halogen requirements of <=1000ppm threshold. Antimony trioxide based flame retardants must also meet the <=1000ppm threshold requirement.

(3) MSL, Peak Temp. - The Moisture Sensitivity Level rating according to the JEDEC industry standard classifications, and peak solder temperature.

(4) There may be additional marking, which relates to the logo, the lot trace code information, or the environmental category on the device.

(5) Multiple Device Markings will be inside parentheses. Only one Device Marking contained in parentheses and separated by a "-" will appear on a device. If a line is indented then it is a continuation of the previous line and the two combined represent the entire Device Marking for that device.

(6) Lead finish/Ball material - Orderable Devices may have multiple material finish options. Finish options are separated by a vertical ruled line. Lead finish/Ball material values may wrap to two lines if the finish value exceeds the maximum column width.

**Important Information and Disclaimer:**The information provided on this page represents TI's knowledge and belief as of the date that it is provided. TI bases its knowledge and belief on information provided by third parties, and makes no representation or warranty as to the accuracy of such information. Efforts are underway to better integrate information from third parties. TI has taken and continues to take reasonable steps to provide representative and accurate information but may not have conducted destructive testing or chemical analysis on incoming materials and chemicals. TI and TI suppliers consider certain information to be proprietary, and thus CAS numbers and other limited information may not be available for release.

In no event shall TI's liability arising out of such information exceed the total purchase price of the TI part(s) at issue in this document sold by TI to Customer on an annual basis.

## GENERIC PACKAGE VIEW

**RGZ 48**

**VQFN - 1 mm max height**

7 x 7, 0.5 mm pitch

PLASTIC QUADFLAT PACK- NO LEAD

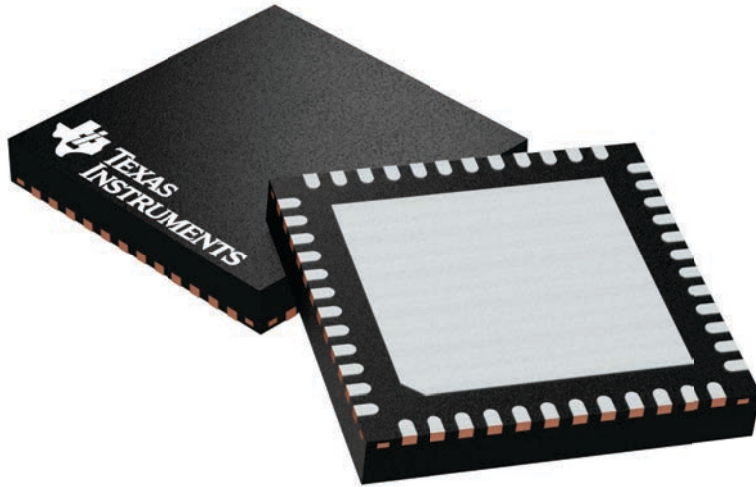

Images above are just a representation of the package family, actual package may vary.  
Refer to the product data sheet for package details.

4224671/A

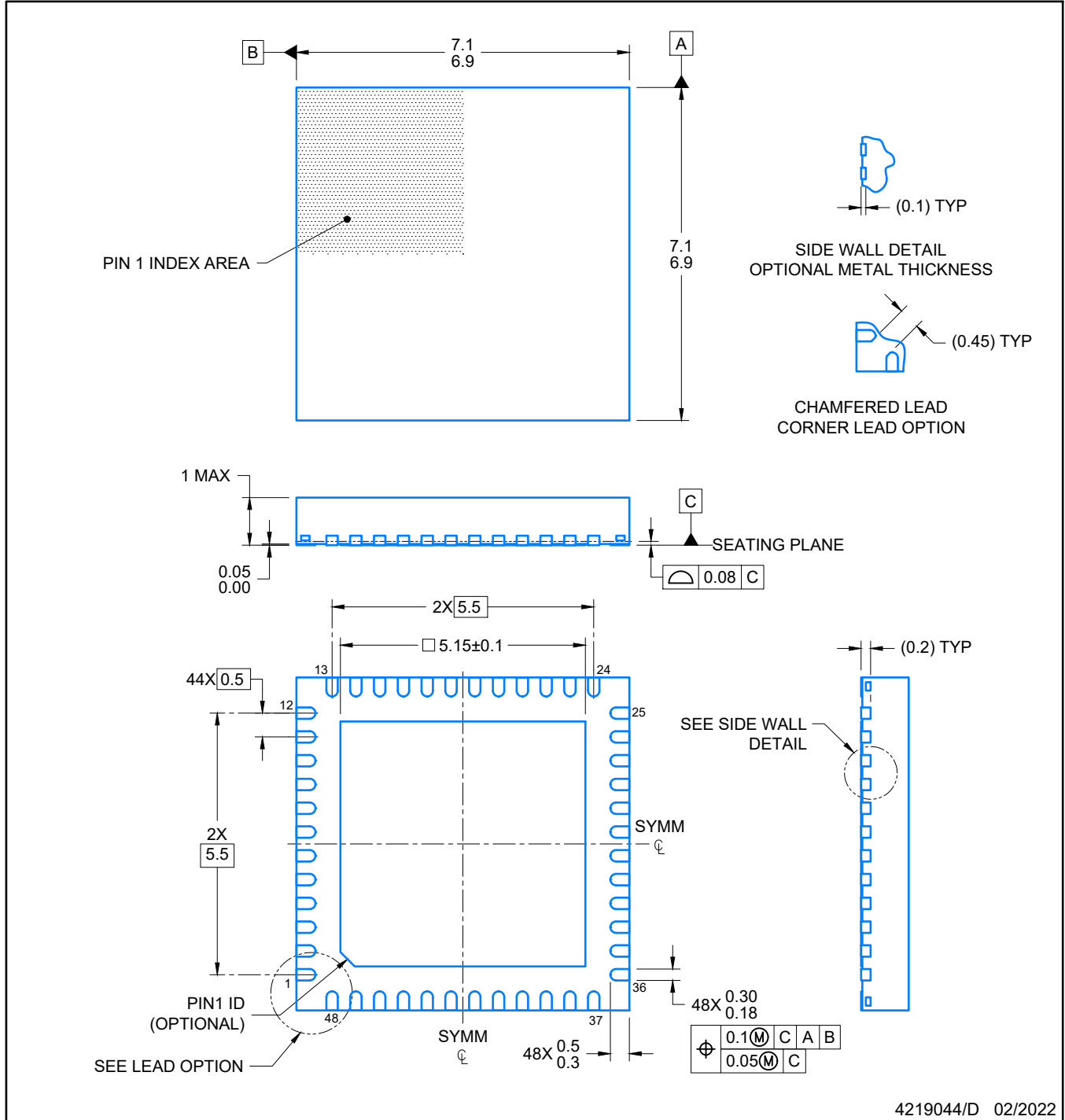

**NOTES:**

1. All linear dimensions are in millimeters. Any dimensions in parenthesis are for reference only. Dimensioning and tolerancing per ASME Y14.5M.
2. This drawing is subject to change without notice.
3. The package thermal pad must be soldered to the printed circuit board for optimal thermal and mechanical performance.

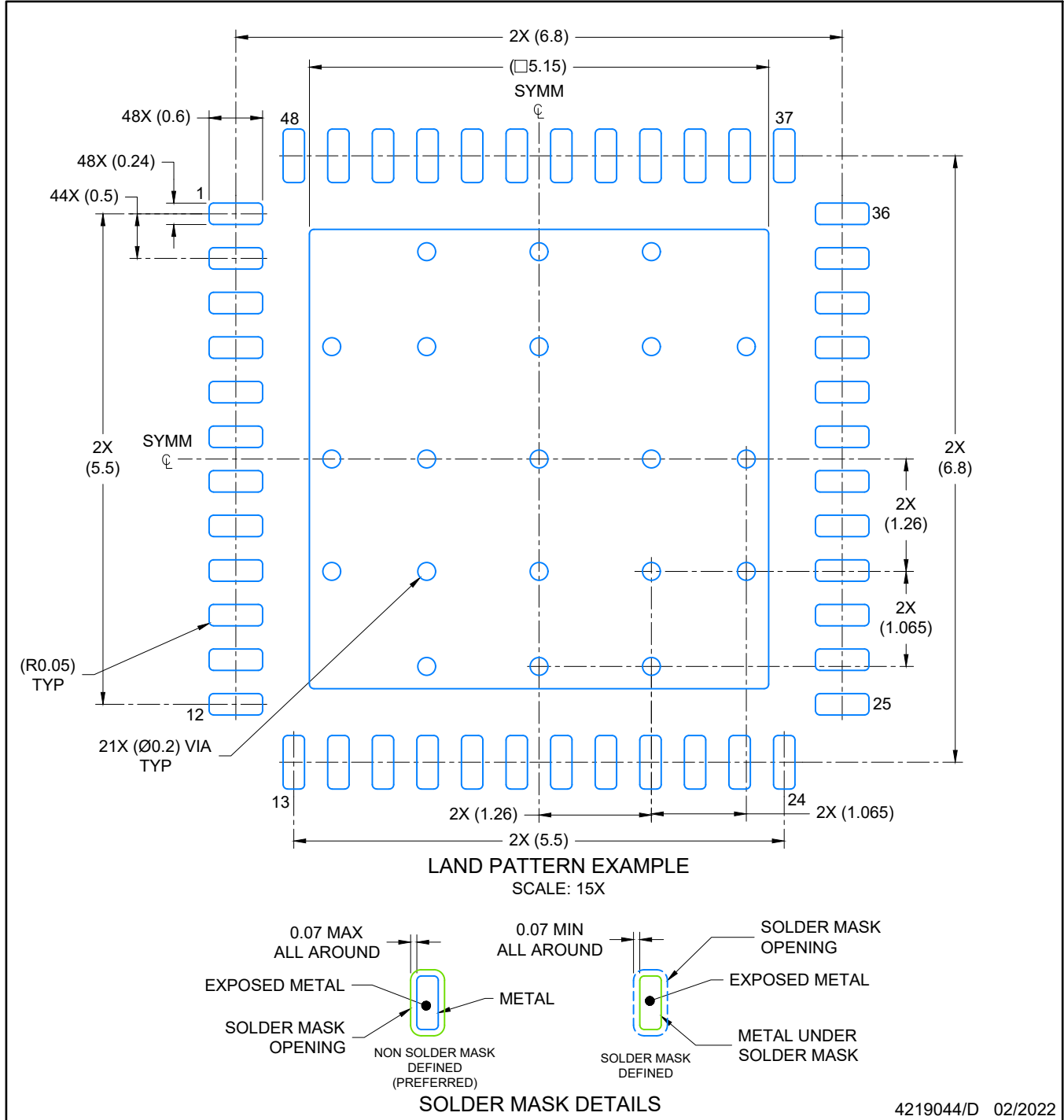

NOTES: (continued)

4. This package is designed to be soldered to a thermal pad on the board. For more information, see Texas Instruments literature number SLUA271 ([www.ti.com/lit/slua271](http://www.ti.com/lit/slua271)).
5. Vias are optional depending on application, refer to device data sheet. If any vias are implemented, refer to their locations shown on this view. It is recommended that vias under paste be filled, plugged or tented.

# EXAMPLE STENCIL DESIGN

RGZ0048A

VQFN - 1 mm max height

PLASTIC QUADFLAT PACK- NO LEAD

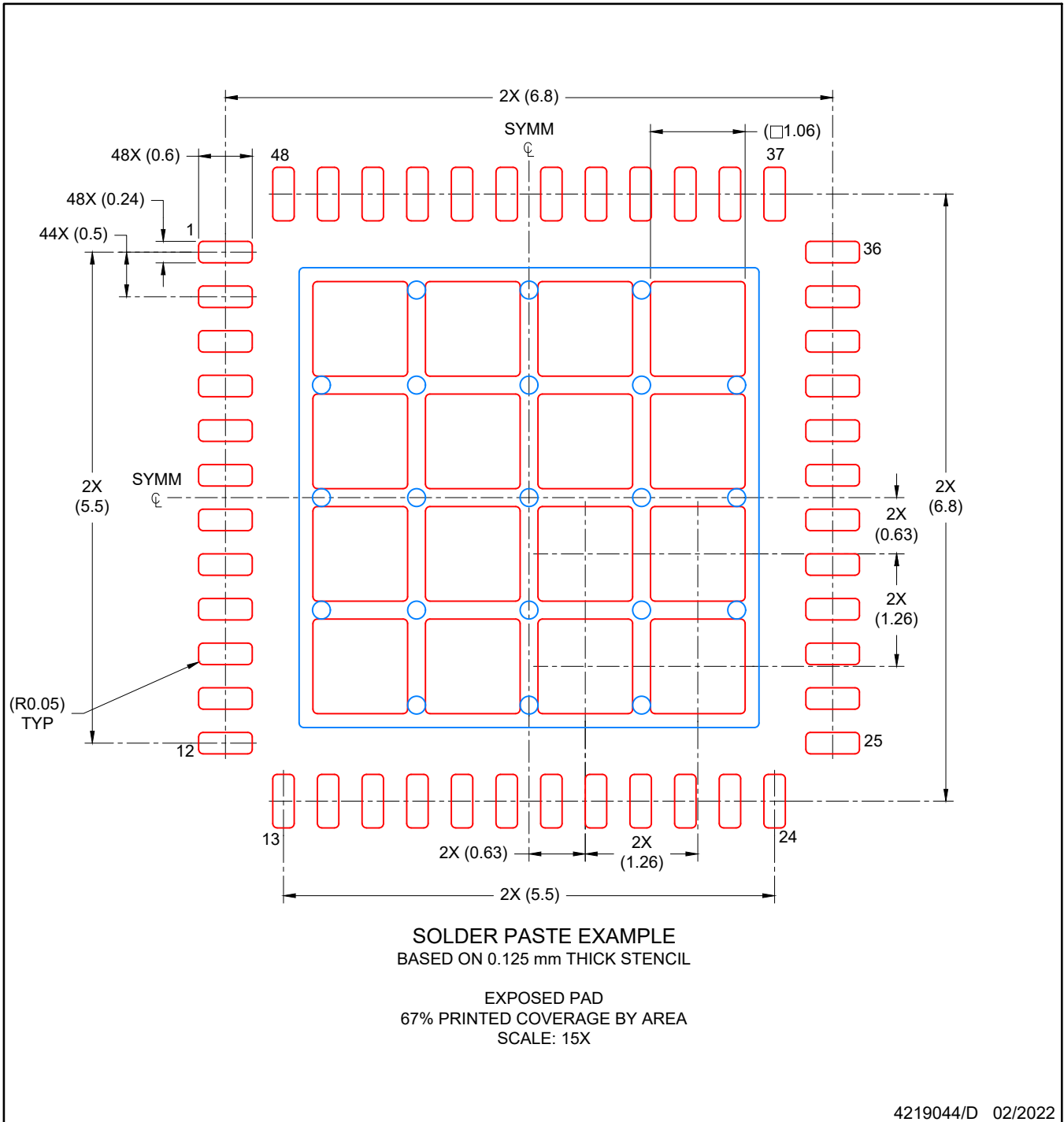

NOTES: (continued)

6. Laser cutting apertures with trapezoidal walls and rounded corners may offer better paste release. IPC-7525 may have alternate design recommendations.

## IMPORTANT NOTICE AND DISCLAIMER

TI PROVIDES TECHNICAL AND RELIABILITY DATA (INCLUDING DATA SHEETS), DESIGN RESOURCES (INCLUDING REFERENCE DESIGNS), APPLICATION OR OTHER DESIGN ADVICE, WEB TOOLS, SAFETY INFORMATION, AND OTHER RESOURCES "AS IS" AND WITH ALL FAULTS, AND DISCLAIMS ALL WARRANTIES, EXPRESS AND IMPLIED, INCLUDING WITHOUT LIMITATION ANY IMPLIED WARRANTIES OF MERCHANTABILITY, FITNESS FOR A PARTICULAR PURPOSE OR NON-INFRINGEMENT OF THIRD PARTY INTELLECTUAL PROPERTY RIGHTS.

These resources are intended for skilled developers designing with TI products. You are solely responsible for (1) selecting the appropriate TI products for your application, (2) designing, validating and testing your application, and (3) ensuring your application meets applicable standards, and any other safety, security, regulatory or other requirements.

These resources are subject to change without notice. TI grants you permission to use these resources only for development of an application that uses the TI products described in the resource. Other reproduction and display of these resources is prohibited. No license is granted to any other TI intellectual property right or to any third party intellectual property right. TI disclaims responsibility for, and you will fully indemnify TI and its representatives against, any claims, damages, costs, losses, and liabilities arising out of your use of these resources.

TI's products are provided subject to [TI's Terms of Sale](#) or other applicable terms available either on [ti.com](http://ti.com) or provided in conjunction with such TI products. TI's provision of these resources does not expand or otherwise alter TI's applicable warranties or warranty disclaimers for TI products.

TI objects to and rejects any additional or different terms you may have proposed.

Mailing Address: Texas Instruments, Post Office Box 655303, Dallas, Texas 75265  
Copyright © 2022, Texas Instruments Incorporated

## Looking for pricing, stock, or lifecycle information?

Click below to explore more details on WIN SOURCE:

 [View TPS65014RGZT on WIN SOURCE](#)

 [Texas Instruments](#) Information

## Optimize Your Supply Chain with WIN SOURCE Solutions

-  Global Sourcing Solution
-  Obsolete Management
-  Cost Control Management
-  Shortage Management
-  Alternative Solution
-  Excess Inventory Management