



**THE DATASHEET OF
TPS61195EVM-460**



TPS61195 WLED Driver for LCD Backlighting With PWM and SMBus Control Interface

Check for Samples: [TPS61195](#)

FEATURES

- 4.5V to 21V Input Voltage
- Integrated 2.5A 50V MOSFET
- 600kHz to 1MHz Programmable Switching Frequency
- Adaptive Boost Output for Best Efficiency
- Designed to Use Small L-C Components
- Internal Loop Compensation
- Eight Current Sinks of 30mA
- Support up to Total 96 LEDs
- 1% Current Matching

- PWM and SMBus Brightness Interface
- 8-bits (256 steps) Brightness Level
- Programmable Over Voltage Threshold
- Built-in WLED Open/Short Protection
- Over Thermal Protection
- 28L 4x4 WQFN

APPLICATIONS

- Notebook/Netbook LCD Display Backlighting

DESCRIPTION

The TPS61195 IC provides highly integrated solutions for large-size LCD backlighting. This device has a built-in high efficiency boost regulator with integrated 2.5A/50V power MOSFET. The eight current sink regulators provide high precision current regulation and matching. In total, the device can support up to 96 LEDs. Unused sinks are disabled by tying them to ground. The boost output automatically adjusts its voltage to the WLED forward voltage to improve efficiency.

The TPS61195 supports multiple brightness dimming methods. During PWM dimming, each IFB pin's current is turned on/off at the duty cycle and frequency determined by an integrated pulse width modulation (PWM). The frequency of this signal is resistor programmable, while the duty cycle is controlled directly either from an external PWM signal input to the DPWM pin or through the SMBUS interface. Additionally, the SMBUS interface provides some operational reporting data such as if one or more strings have failed or if the IC is over-heating. In direct PWM dimming mode, each IFB current is turned on/off at same duty cycle and frequency as the PWM signal input on the DPWM pin. In analog dimming mode, the input PWM duty cycle information is translated to analog signal to control the WLED current signal linearly over 1% to 100% brightness area.

The TPS61195 integrates over-current and short-circuit protection, soft start and over temperature protection circuit. The device also provides programmable output over-voltage protection, and the threshold is adjusted by external resistor divider combination.

The TPS61195 IC has built-in linear regulator for the IC supply. The device is in a 4x4 mm QFN package.



Please be aware that an important notice concerning availability, standard warranty, and use in critical applications of Texas Instruments semiconductor products and disclaimers thereto appears at the end of this data sheet.

TPS61195 TYPICAL APPLICATION

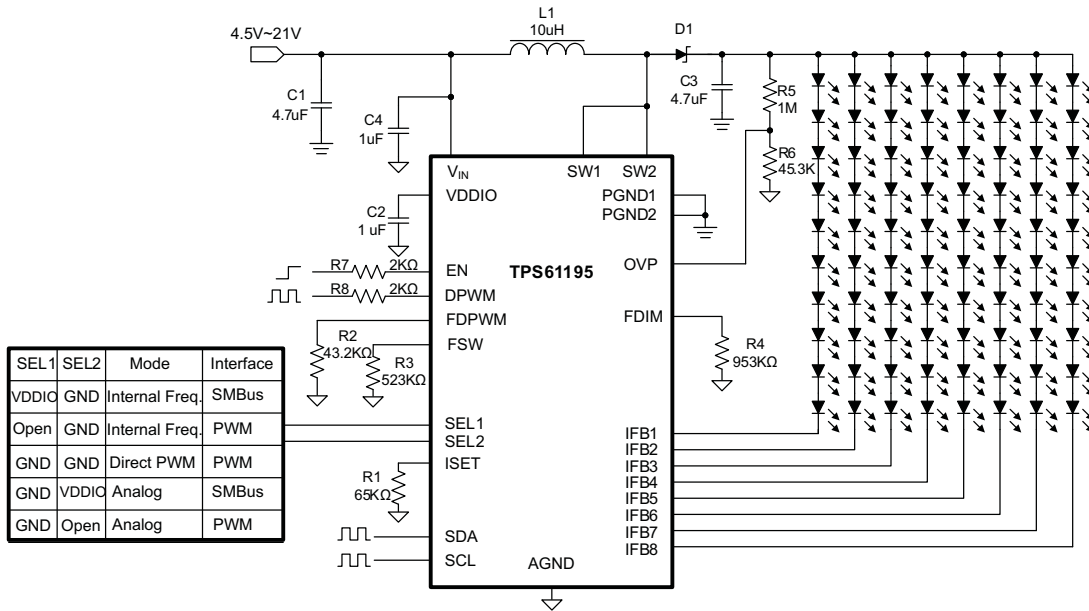

PINOUT

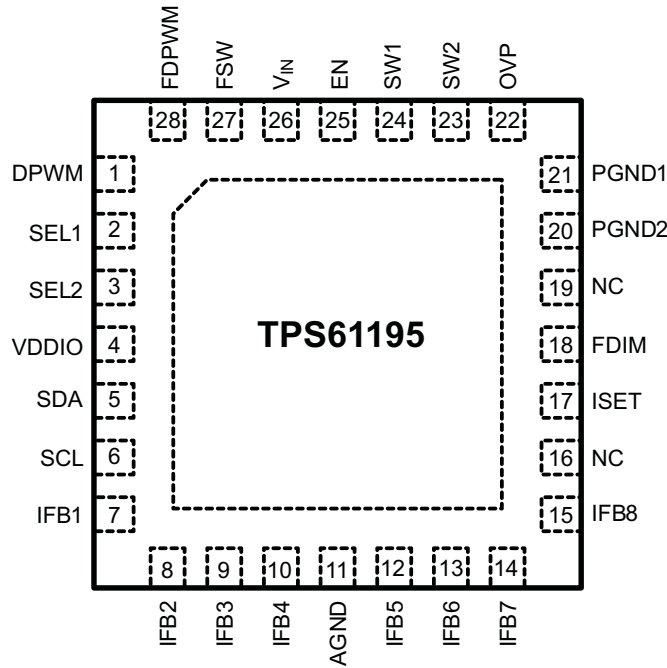

PIN FUNCTIONS

PIN		DESCRIPTION
NO.	NAME	
1	DPWM	PWM signal input pin. The frequency of PWM signal must be in the range of 200Hz to 20kHz
2	SEL1	Dimming mode selection pin. See Table 1 for a detailed explanation.
3	SEL2	Dimming mode selection pin. See Table 1 for a detailed explanation.
4	VDDIO	Serial bus voltage level pin. This pin should only have the recommended capacitive load.
5	SDA	SMBus data input/output pin
6	SCL	SMBus clock input pin
7–10, 12–15	IFB1 to IFB4 IFB5 to IFB8	Regulated 30mA typical current sink input pins. Connect the cathode of the last LED in each of the eight strings to one of these pins.
11	AGND	Analog ground
16	N.C	AGND internal. External to AGND is recommended.
17	ISET	Full-scale LED current set pin. Connecting a resistor from this pin to AGND programs the maximum current level.
18	FDIM	Dimming frequency program pin with an external resistor. Connecting a resistor from this pin to AGND programs the internal PWM dimming frequency.
19	N.C	AGND internal. External track tie to AGND is recommended.
20, 21	PGND2, PGND1	Power ground
22	OVP	Over-voltage program pin. A resistor divider between the boost converter output to AGND, with mid point tied to this pin sets the over-voltage protection threshold.
23,24	SW2, SW1	Drain connection of the internal power FET
25	EN	SDAble and Disable Pin. EN high = SDAble, EN low = Disable and de-activates SMBus interface.
26	VIN	Supply input pin
27	FSW	Switching frequency select pin. Use a resistor to set the frequency between 600kHz to 1.0MHz
28	FDPWM	Place a 43.2kΩ resistor from this pin to AGND programming the internal clock for counting PWM input duty cycle.

FUNCTIONAL BLOCK DIAGRAM

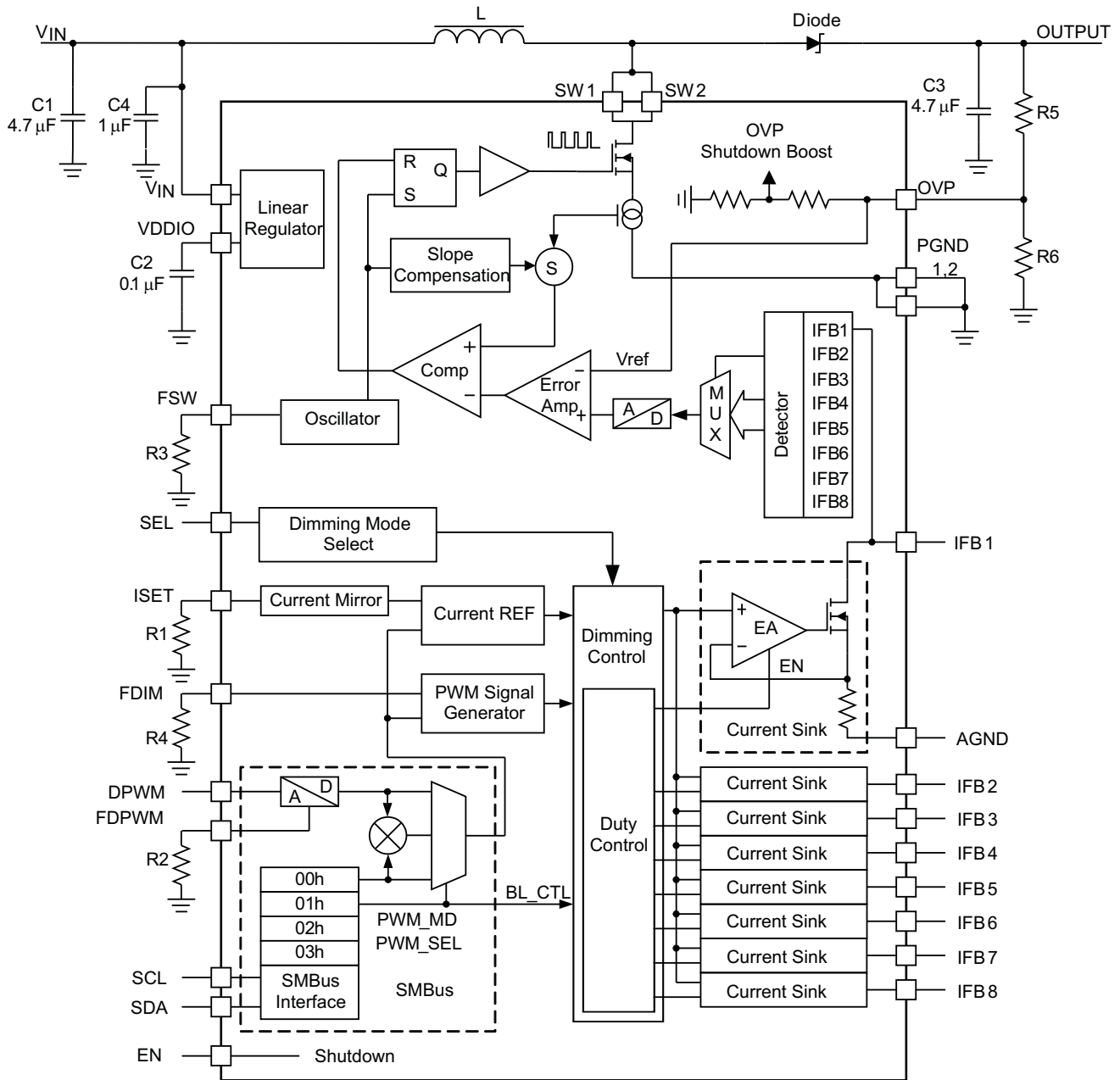

ORDERING INFORMATION

PACKAGE	PACKAGE MARKING
TPS61195RUY	TPS61195

ABSOLUTE MAXIMUM RATINGS⁽¹⁾

over operating free-air temperature range (unless otherwise noted)

		VALUE	UNIT
Voltages on pin V _{IN} ⁽²⁾		–0.3 to 24	V
Voltages on pin EN, DPWM, SDA and SCL ⁽²⁾		–0.3 to 7	V
Voltage on pin SW1 and SW2 ⁽²⁾		–0.3 to 50	V
Voltage on pin IFB1 to IFB8 ⁽²⁾		–0.3 to 20	V
Voltage on all other pins ⁽²⁾		–0.3 to 3.6	V
ESD rating	HBM	2	kV
	MM	200	V
	CDM	700	V
Continuous power dissipation		See Dissipation Rating Table	
Operating junction temperature range		–40 to 150	°C
Storage temperature range		–65 to 150	°C
Lead temperature (soldering, 10 sec)		260	°C

- (1) Stresses beyond those listed under *absolute maximum ratings* may cause permanent damage to the device. These are stress ratings only, and functional operation of the device at these or any other conditions beyond those indicated under *recommended operating conditions* is not implied. Exposure to absolute-maximum-rated conditions for extended periods may affect device reliability.
- (2) All voltage values are with respect to network ground terminal.

THERMAL INFORMATION

THERMAL METRIC ⁽¹⁾		TPS61195	UNITS
		RUY (28 PINS)	
θ_{JA}	Junction-to-ambient thermal resistance	34.3	°C/W
θ_{JTop}	Junction-to-case (top) thermal resistance	31.3	
θ_{JB}	Junction-to-board thermal resistance	9.5	
ψ_{JT}	Junction-to-top characterization parameter	0.2	
ψ_{JB}	Junction-to-board characterization parameter	8.6	
θ_{JBot}	Junction-to-case (bottom) thermal resistance	2.1	

- (1) For more information about traditional and new thermal metrics, see the *IC Package Thermal Metrics* application report, [SPRA953](#).

RECOMMENDED OPERATING CONDITIONS

		MIN	TYP	MAX	UNIT
V _{IN}	Input voltage range	4.5		21	V
V _{OUT}	Output voltage range	V _{in}		45	V
L	Inductor	4.7		10	μH
C _I	Input capacitor	1			μF
C _O	Output capacitor	2.2		10	μF
F _{PWM_O}	IFBx PWM dimming frequency set by resistor to ANG1 on FDIM	0.2		5	kHz
F _{PWM_I}	PWM input signal frequency (SMBus mode)		10		kHz
	PWM input signal frequency (PWM mode)	0.2		20	
F _{BOOST}	Boost regulator switching frequency	600		1000	kHz
T _A	Operating ambient temperature	–40		85	°C
T _J	Operating junction temperature	–40		125	°C

ELECTRICAL CHARACTERISTICS

$V_{IN} = 12V$, DPWM and EN = high, IFB current = 20mA, IFB voltage = 500mV, $T_A = -40^{\circ}C$ to $85^{\circ}C$, typical values are at $T_A = 25^{\circ}C$ (unless otherwise noted)

PARAMETER		TEST CONDITIONS	MIN	TYP	MAX	UNIT
SUPPLY CURRENT						
V_{IN}	Input voltage range		4.5		21	V
I_{Q_VIN}	Operating quiescent current into V_{IN}	Not Switching and no load, $V_{IN} = 21V$			3	mA
VDDIO	VDDIO pin output voltage	$V_{IN} > 5.5V$, $I_{load} = 5\text{ mA}$	2.7	3.15	3.6	V
I_{EN}	Shutdown current	$V_{IN} = 12V$, EN = low $V_{IN} = 21V$, EN = low			10 15	μA
V_{IN_UVLO}	V_{IN} under-voltage lockout threshold	V_{IN} ramp down V_{IN} ramp up			3.55 3.80	V
V_{IN_Hys}	V_{IN} under-voltage lockout hysteresis			250		mV
EN, SCL, SDA AND PWM						
V_H	EN Logic high threshold		1.2			V
V_L	EN Logic low threshold				0.4	
V_H	DPWM logic high threshold		2.1			
V_L	DPWM logic low threshold				0.7	V
V_H	SDA, SCL logical high threshold		2.0			
V_L	SDA, SCL logic low threshold				0.8	
V_{SDA_L}	SDA logic low voltage	$I_{SOURCE} = 4\text{ mA}$			0.4	V
R_{PD_EN}	Pull down resistor on EN		400	800	1600	k Ω
R_{PD_PWM}	Pull down resistor on DPWM		400	800	1600	k Ω
$I_{leakage}$	Leakage current on EN and DPWM	$V = 5V$ $V = 0V$	3.125 -100		12.5 100	μA nA
R_{PD_SMBus}	Pull down resistor on SCL and SDA		1	2	4	M Ω
CURRENT REGULATION						
V_{ISET}	ISET pin voltage		1.204	1.229	1.253	V
K_{ISET}	Current multiply I_{FB}/I_{SET}	$I_{ISET} = 18.9\ \mu A$, D = 100%		1060		
I_{FB_AVG}	Average current accuracy	$I_{ISET} = 18.9\ \mu A$, D = 100% $T_A = 0^{\circ}C$ to $85^{\circ}C$	-1.5%		+1.5%	
I_{FB_L}	Low current accuracy	$I_{ISET} = 18.9\ \mu A$, D = 12.5%, analog $T_A = 0^{\circ}C$ to $85^{\circ}C$	-5%		+5%	
K_m	$(I_{max} - I_{min})/I_{AVG}$	$I_{ISET} = 18.9\ \mu A$, D = 100% $T_A = 0^{\circ}C$ to $85^{\circ}C$		1%	3%	
I_{leak}	IFB pin leakage current	IFB voltage = 15 V on all pins IFB voltage = 5 V on all pins, total			5 1	μA
I_{IFB_max}	Current sink max output current	IFB = 450 mV	30			mA
I_{IFB_range}	Programmable current sink regulator range		0		30	mA
f_{dim}	Internal PWM dimming frequency	$R_{FDIM} = 953k\Omega$	190	210	230	Hz
BOOST OUTPUT REGULATION						
V_{IFB_L}	Output voltage dial up threshold	Measured on $V_{IFB(min)}$		450		mV
V_{IFB_H}	Output voltage dial down threshold	Measured on $V_{IFB(min)}$		750		mV
POWER SWITCH						
R_{PWM_SW}	PWM FET on-resistance	$V_{IN} = 12V$		0.15	0.35	Ω
I_{LN_NFET}	PWM FET leakage current	$V_{SW} = 50V$, $T_A = 25^{\circ}C$			2	μA

ELECTRICAL CHARACTERISTICS (continued)

$V_{IN} = 12V$, DPWM and EN = high, IFB current = 20mA, IFB voltage = 500mV, $T_A = -40^{\circ}C$ to $85^{\circ}C$, typical values are at $T_A = 25^{\circ}C$ (unless otherwise noted)

PARAMETER		TEST CONDITIONS	MIN	TYP	MAX	UNIT
OSCILLATOR						
f_S	Oscillator frequency	$R_{FSW} = 523k\Omega$	0.8	1.0	1.2	MHz
D_{max}	Maximum duty cycle	IFB = 0V	94%			
D_{min}	Minimum duty cycle	$R_{FSW} = 523k\Omega$	10%			
OC, SC, OVP AND SS						
I_{LIM}	N-Channel MOSFET current limit	$D = D_{max}$	2.5		4.5	A
V_{CLAMP_TH}	Output voltage clamp program threshold		1.90	1.95	2.00	
V_{OV_TH}	Output over voltage program threshold		1.98	2.03	2.08	V
V_{OVP_IFB}	IFB overvoltage threshold	Measured on the IFBx pin, IFB on	12.5	14	15.5	V
V_{OVP2_IFB}	2 nd Level IFB overvoltage threshold	Measured on the IFBx pin, IFB on or off	18			V
V_{IFB_nose}	IFB no use detection threshold during startup	IFB voltage rising		0.75		V
V_{OL}	OVP pin overload detection	Output voltage drop	60%			
THERMAL SHUTDOWN						
$T_{shutdown}$	Thermal shutdown threshold		150			$^{\circ}C$

TYPICAL CHARACTERISTICS

TABLE OF GRAPHS

		FIGURE
Load efficiency TPS61195	$V_{in} = 10.8\text{ V}$; $V_{out} = 33, 37\text{ and }41\text{ V}$; $L = 10\ \mu\text{H}$	Figure 1
Load efficiency TPS61195	$V_{in} = 7\text{ V}, 10.8\text{ V and }21\text{ V}$, $V_{out} = 33\text{ V}$; $L = 10\ \mu\text{H}$	Figure 2
PWM dimming efficiency	$V_{in} = 7\text{ V}, 10.8\text{ V and }21\text{ V}$, $V_{out} = 41\text{ V}$; $L = 10\ \mu\text{H}$; $I_{SET} = 18.9\ \mu\text{A}$	Figure 3
PWM dimming efficiency	$V_{in} = 7\text{ V}, 10.8\text{ V and }21\text{ V}$, $V_{out} = 33\text{ V}$; $L = 10\ \mu\text{H}$; $I_{SET} = 18.9\ \mu\text{A}$	Figure 4
Dimming linearity	$V_{in} = 10.8\text{ V}$; $V_{out} = 41\text{ V}$; $L = 10\ \mu\text{H}$; $I_{SET} = 18.9\ \mu\text{A}$; $F_{DIM} = 2\text{ kHz}$	Figure 5
Dimming linearity	$V_{in} = 10.8\text{ V}$; $V_{out} = 41\text{ V}$; $L = 10\ \mu\text{H}$; $I_{SET} = 18.9\ \mu\text{A}$; $F_{DIM} = 210\text{ Hz}$	Figure 6
Boost switch Frequency	$V_{in} = 10.8\text{ V}$; $V_{out} = 41\text{ V}$; $L = 10\ \mu\text{H}$; $I_{SET} = 18.9\ \mu\text{A}$	Figure 7
Dimming Frequency	$V_{in} = 10.8\text{ V}$; $V_{out} = 41\text{ V}$; $L = 10\ \mu\text{H}$; $I_{SET} = 18.9\ \mu\text{A}$	Figure 8
Switch waveform	$V_{in} = 10.8\text{ V}$; $V_{out} = 41\text{ V}$; $L = 10\ \mu\text{H}$; $I_{SET} = 18.9\ \mu\text{A}$	Figure 9
Switch waveform	$V_{in} = 21.0\text{ V}$; $V_{out} = 41\text{ V}$; $L = 10\ \mu\text{H}$; $I_{SET} = 18.9\ \mu\text{A}$	Figure 10
Analog dimming	$V_{in} = 10.8\text{ V}$; $V_{out} = 41\text{ V}$; $L = 10\ \mu\text{H}$; $I_{SET} = 18.9\ \mu\text{A}$; $F_{DIM} = 210\text{ Hz}$; $D = 45\%$	Figure 11
Direct PWM dimming	$V_{in} = 10.8\text{ V}$; $V_{out} = 41\text{ V}$; $L = 10\ \mu\text{H}$; $I_{SET} = 18.9\ \mu\text{A}$; $F_{DIM} = 210\text{ Hz}$; $D = 50\%$	Figure 12
Output ripple when PWM dimming	$V_{in} = 10.8\text{ V}$; $V_{out} = 41\text{ V}$; $L = 10\ \mu\text{H}$; $I_{SET} = 18.9\ \mu\text{A}$; $F_{DIM} = 210\text{ Hz}$	Figure 13
Startup waveform	$V_{in} = 10.8\text{ V}$; $V_{out} = 41\text{ V}$; $L = 10\ \mu\text{H}$; $I_{SET} = 18.9\ \mu\text{A}$	Figure 14

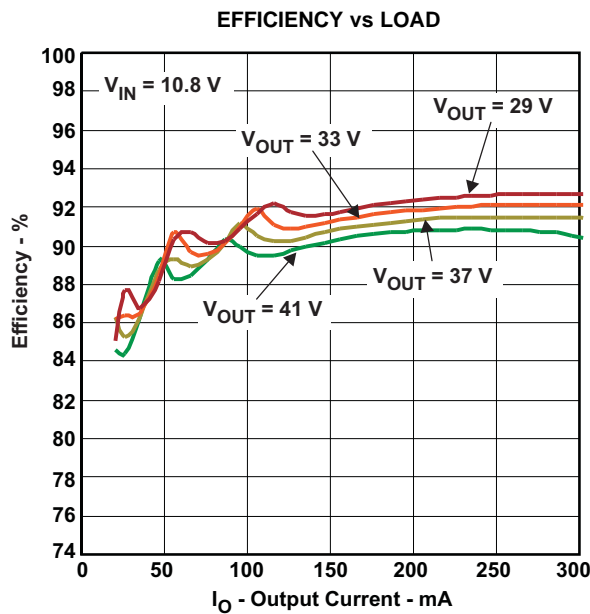

Figure 1.

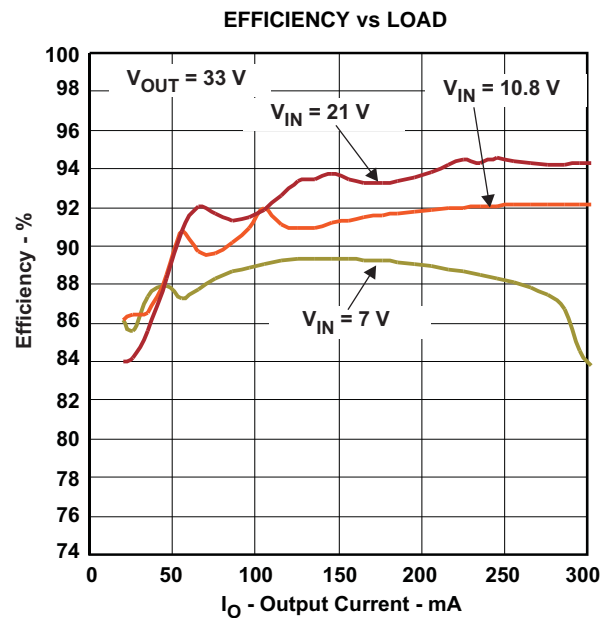

Figure 2.

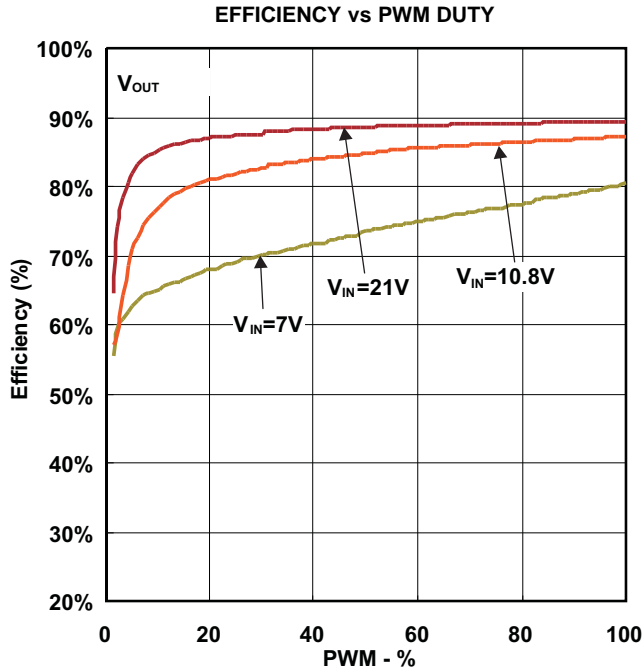

Figure 3.

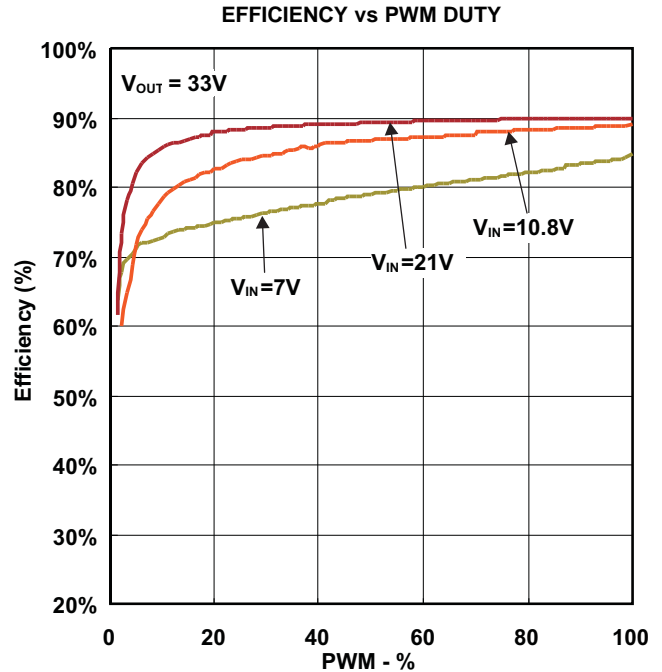

Figure 4.

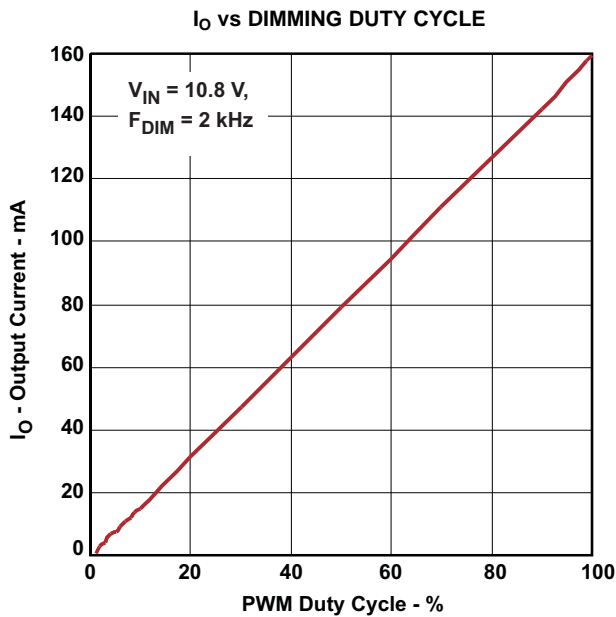

Figure 5.

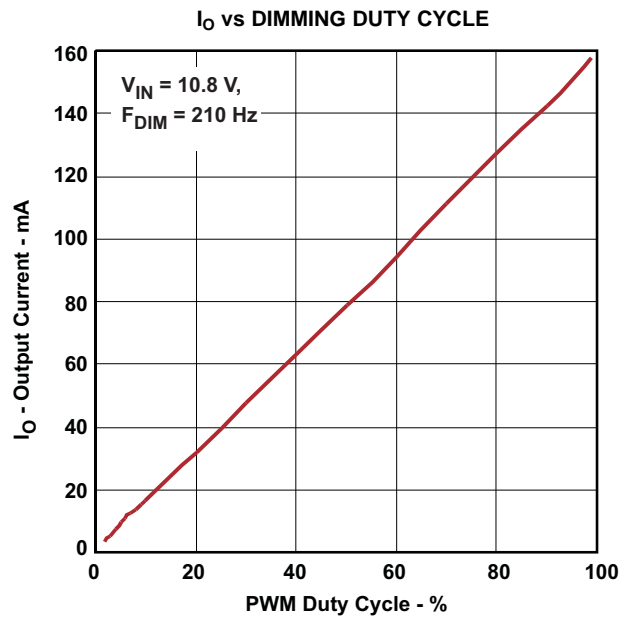

Figure 6.

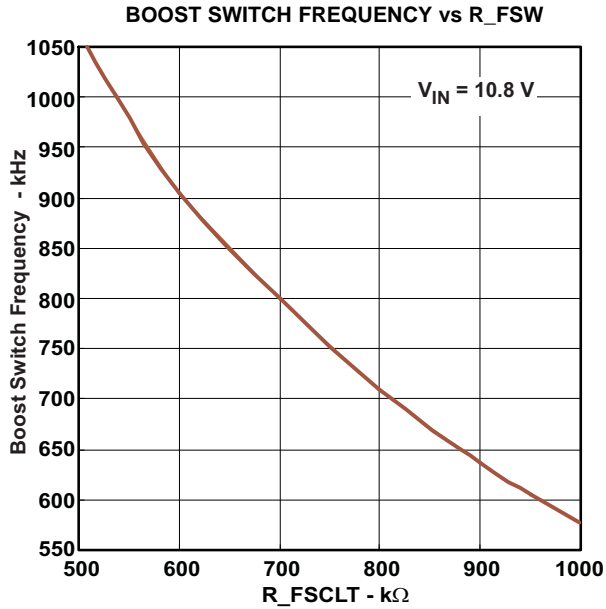

Figure 7.

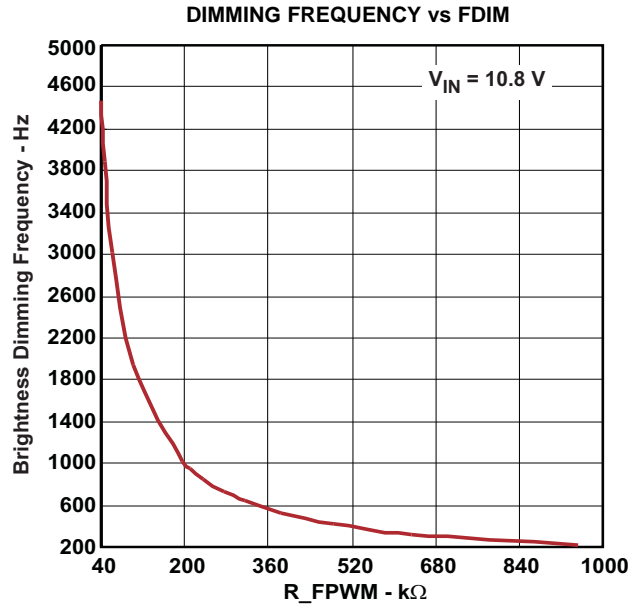

Figure 8.

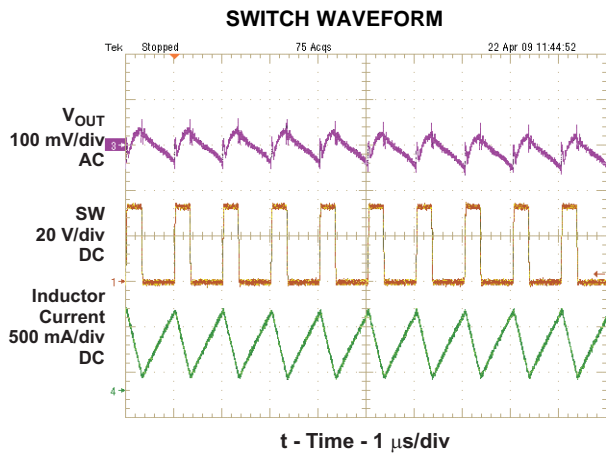

Figure 9.

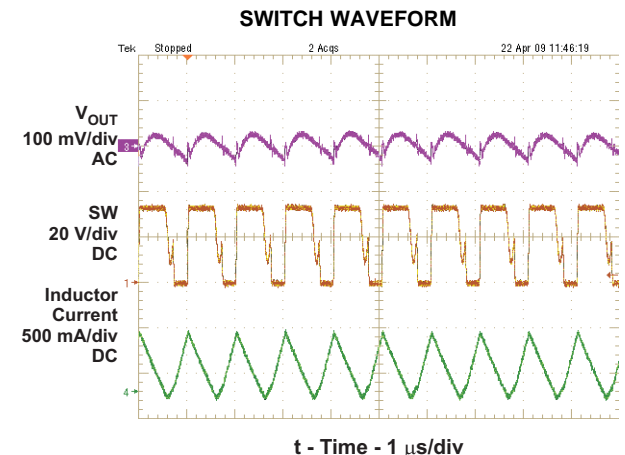

Figure 10.

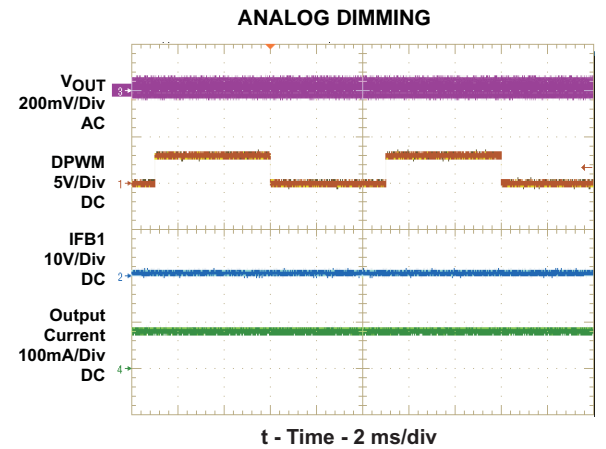

Figure 11.

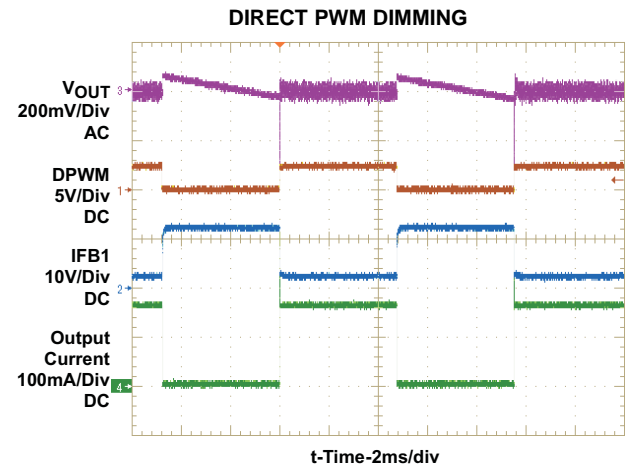

Figure 12.

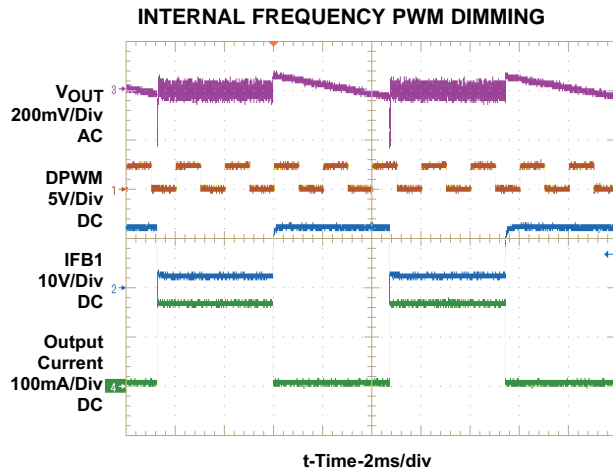

Figure 13.

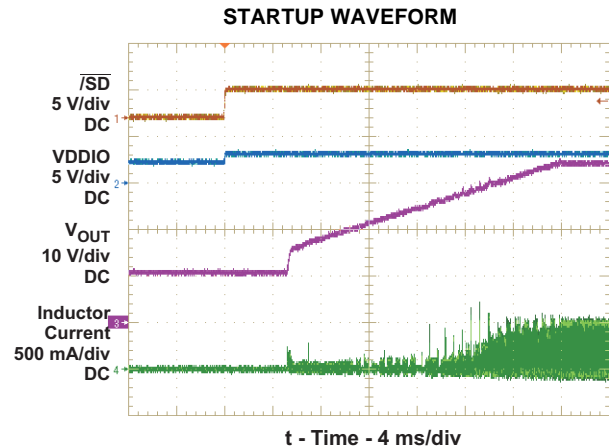

Figure 14.

DETAILED DESCRIPTION

NORMAL OPERATION

The TPS61195 is a high efficiency, high output voltage white LED driver for notebook panel backlighting applications. The advantages of white LEDs compared to CCFL backlights are higher power efficiency and lower profile design. Due to the large number of white LEDs required to provide backlighting for medium to large display panels, the LEDs must be arranged in parallel strings of several LEDs in series. Therefore, the backlight driver for battery powered systems is almost always a boost regulator with multiple current sink regulators. Having more white LEDs in series reduces the number of parallel strings and therefore improves overall current matching. However, the efficiency of the boost regulator declines due to the need for high output voltage. Also, there must be enough white LEDs in series to ensure the output voltage stays above the input voltage range.

However, the TPS61195 boost regulator operates in pulse skip mode if the input voltage on the V_{IN} pin is slightly higher than total WLED forward voltage. In pulse skip mode, the main switch turns on/off for several cycles to charge the inductor and output capacitor. The device continues to regulate the output voltage and current sinks continue to regulate the IFB pin current.

The TPS61195 IC has integrated all of the key function blocks to power and control up to 96 white LEDs. The device includes a 50V/2.5A boost regulator, eight 30mA current sink regulators and protection circuits for over-current, over-voltage and short circuit failures. Multiple IFB pins can be connected together to accommodate high current LEDs.

The TPS61195 integrates three dimming methods including traditional "no delay" PWM dimming and analog dimming control as well as direct PWM dimming. In addition, the TPS61195 provides two control interface methods. These are explained in further detail in the [BRIGHTNESS DIMMING CONTROL](#) section.

SUPPLY VOLTAGE

The TPS61195 IC has a built-in LDO linear regulator to supply the IC analog and logic circuit. The regulator output is connected to the VDDIO pin. The regulator turns on when V_{IN} is applied to the IC but does not reach regulation until the EN pin is pulled high. A 1 μ F bypass capacitor on the VDDIO pin is required for the LDO to be control loop stable. In addition, avoid connecting the VDDIO pin to any other circuit as this could introduce the noise into the IC supply voltage.

The voltage on the V_{IN} pin is the input of the internal LDO, and powers the IC. There is an under-voltage lockout on the V_{IN} pin which disables the IC when its voltage falls to 3.55V (Maximum). The IC restarts when the V_{IN} pin voltage recovers by 250mV.

BOOST REGULATOR AND PROGRAMMABLE SWITCH FREQUENCY (FSW)

The fixed-frequency PWM boost converter uses current-mode control and has integrated loop compensation. The internal compensation ensures stable output over the full input and output voltage range assuming the recommended inductance and output capacitance values in the [RECOMMENDED OPERATING CONDITIONS](#) are used. The output voltage of the boost regulator is automatically set by the IC to minimize the voltage drop across the IFB pins. The IC regulates the lowest IFB pin to 450mV, and consistently adjusts the boost output voltage to account for any changes in LED forward voltages. If the input voltage is higher than the sum of the white LED forward voltage drops (e.g. at low duty cycles), the boost converter will not be able to regulate the output due to its minimum duty cycle limitation. In this case, increase the number of WLED in series or include series ballast resistors in order to provide enough headroom for the converter to boost the output voltage. Since the TPS61195 integrates a 2.5A/50V power MOSFET, the boost converter can provide up to a 45V output voltage.

The TPS61195 switch frequency is programmable between 600 KHz to 1.0 MHz by the resistor value on the FSW pin and roughly following [Equation 1](#):

$$F_{SW} \approx \frac{5.23 \times 10^{11}}{R_{FSW}} \quad (1)$$

Where

$$R_{FSW} = \text{FSW pin resistor}$$

See [Figure 7](#) for boost converter switching frequency adjustment resistor R_{FSW} selection.

The adjustable switching frequency feature provides the user with the flexibility of choosing a faster switching frequency, and therefore, an inductor with smaller inductance and footprint or slower switching frequency, and therefore, potentially higher efficiency due to lower switching losses.

LED CURRENT SINKS

The eight current sink regulators embedded in TPS61195 can be collectively configured to provide up to a maximum of 30mA. These eight specialized current sinks are accurate to within -3% minimum and +2% maximum for currents above 10 mA, with a string-to-string difference of $\pm 1\%$. The IFB current must be programmed to the highest WLED current expected using the ISET pin resistor and the following [Equation 2](#).

$$I_{FB} = \frac{V_{ISET}}{R_{ISET}} \times K_{ISET} \quad (2)$$

Where

$$K_{ISET} = \text{Current multiple (1060 typical)}$$

$$V_{ISET} = \text{ISET pin voltage (1.229V typical)}$$

$$R_{ISET} = \text{ISET pin resistor}$$

ENABLE AND SOFT STARTUP

The TPS61195 integrates power up sequency control circuit which provides free power up sequency to system. A logic high signal on the EN pin turns on the internal LDO linear regulator which provides VDDIO to activate the IC. After the device is disabled, the TPS61195 checks the status of all current feedback channels and shuts down any unused feedback channels.

After the device is enabled, if the PWM pin is left floating, the output voltage of TPS61195 regulates to the minimum output voltage. Once the IC detects a voltage on the PWM pin, the TPS61195 begins to regulate the IFB pin current, as pre-set per the ISET pin resistor, times the duty cycle of the signal on the PWM pin. The boost converter's output voltage rises to the appropriate level to accommodate the sum of the white LED string with the highest forward voltage drops plus 450mV typical at that current.

The TPS61195 has an integrated soft-start circuit to avoid any inrush current during the startup. During the startup period, the output voltage rises from minimum output voltage in approximately 100mV increments. The output voltage will not stop rising until all IFB pin voltages are above 450mV and all IFB pin currents are sinking the pre-set value. The startup period depends on the expected output voltage and can be predicted by [Equation 3](#).

$$t = K \times \left(V_{OUT} \times \frac{R6}{R5+R6} - 0.72 \text{ V} \right) \quad (3)$$

Where

$$K = 26\text{ms/V}$$

Pulling the EN pin low immediately shuts down the IC, resulting in the IC consuming less than 50µA in the shutdown mode.

UNUSED IFB PIN

If the application requires less than 8 WLED strings, one can easily disable unused IFB pins. The TPS61195 simply requires leaving the unused IFB pin open or shorting it to ground. If the IFB pin is open, the boost output voltage ramps up to the preset over-voltage threshold set per the V_{OVP} pin during start up. The IC then detects the zero current string, and removes it from the feedback loop. If the IFB pin is shorted to ground, the IC detects the voltage less than V_{IFB_nouse} threshold typically 0.75V and immediately disables the string after the IC is enabled. Thus, the boost output voltage ramps to the regulation voltage immediately following soft start and does not go up to the over-voltage threshold.

BRIGHTNESS DIMMING CONTROL

The TPS61195 integrates several methods of dimming control and two user control interfaces as summarized in the [TYPICAL APPLICATION CIRCUIT](#) and [Table 1](#). If the PWM interface is selected then all of the methods are a function of the input PWM signal duty cycle. If the SMBus interface is selected, then the white LED brightness is adjustable through a standard SMBus 2.0 instruction set which is fully compatible with the DELL white LED backlighting SMBus protocol. An added benefit of using the SMBus interface is digital reporting of operation conditions.

The no-delay PWM dimming method uses the internal PWM dimming frequency, set by the resistor on the FDIM pin, while direct PWM dimming uses the frequency supplied by the input signal on the DPWM pin. Compared to analog dimming, PWM dimming provides better brightness linearity and less color shift over the entire PWM dimming range. With direct and no-delay PWM dimming implemented, the IC turns on and off all eight current sink regulators at the same duty cycle as the input PWM signal. See section [NO DELAY PWM DIMMING](#).

The IC also can also be configured for analog dimming. In this mode, the IC modulates all eight current sink regulators as a function of the input PWM signal duty cycle. Compared to PWM dimming, analog dimming provides higher power and electrical to optical efficiency as well as eliminates output ripple that can cause some ceramic output capacitors to generate audible noise.

Table 1. Brightness Control and Dimming Method List

SEL1	SEL2	MODE	INTERFACE
VDDIO	GND	No delay PWM	SMBus
OPEN	GND	No delay PWM	PWM
GND	VDDIO	Analog	SMBus
GND	OPEN	Analog	PWM
GND	GND	Direct PWM	PWM

ADJUSTABLE PWM DIMMING FREQUENCY (FDIM)

The TPS61195 has a built-in oscillator to generate the internal PWM dimming signal. Each IFB current regulator sink is turned on/ off at this oscillator's frequency. The built-in oscillator's frequency is adjustable with an external resistor R_{FDIM} on the FDIM pin in the range of 100Hz to 5KHz roughly following [Equation 4](#):

$$F_{DIM} \approx \frac{2 \times 10^8}{R_{FDIM}} \quad (4)$$

Where

$$R_{FDIM} = \text{FDIM pin resistor}$$

The adjustable range of the R_{FDIM} resistor is from 40k Ω to 1M Ω , corresponding to the dimming frequency, F_{DIM} , of 200Hz to 5kHz. See [Figure 8](#) for PWM dimming frequency adjustment resistor R_{FDIM} selection and [Table 2](#) for the resistor value recommendation list.

Table 2. R_{FDIM} Recommendations

RFDIM	FDIM
953 k Ω	210 Hz
200 k Ω	1 kHz
100 k Ω	2 kHz

PWM AND SMBUS INPUT BRIGHTNESS CONTROL INTERFACE

The TPS61195 controls the white LED brightness by the PWM signal on the PWM pin or SMBus instruction input on the SCL and SDA pins. Using the PWM control interface, the TPS61195 integrates a high-speed, high-precision digital counter to calculate the PWM duty cycle on the PWM pin. The PWM duty cycle digital counter auto-adjusts the sample rate for a 200Hz to 20 kHz PWM input signal. The key benefit of the digital counter is cycle-by-cycle high-speed sampling and computing which allows the current sinks to easily respond to the input PWM duty cycle within one cycle. After counting, the input PWM duty cycle information is saved as in an eight-bit internal register. Alternatively, under SMBus control, the user sends the eight-bit brightness information to the TPS61195 for direct storage in the internal register. The TPS61195 turns on and off each IFB current channel using the duty cycle information that is stored in this internal register.

A 43.2k Ω resistor is required on the FDPWM pin to set the bias current for the internal digital counter.

NO DELAY PWM DIMMING

In this mode, all used IFB channels are turn on and off together at the F_{DIM} frequency which is set by R_{FDIM} on the FDIM pin. [Figure 15](#) gives the timing diagram for each channel in No Delay PWM dimming mode.

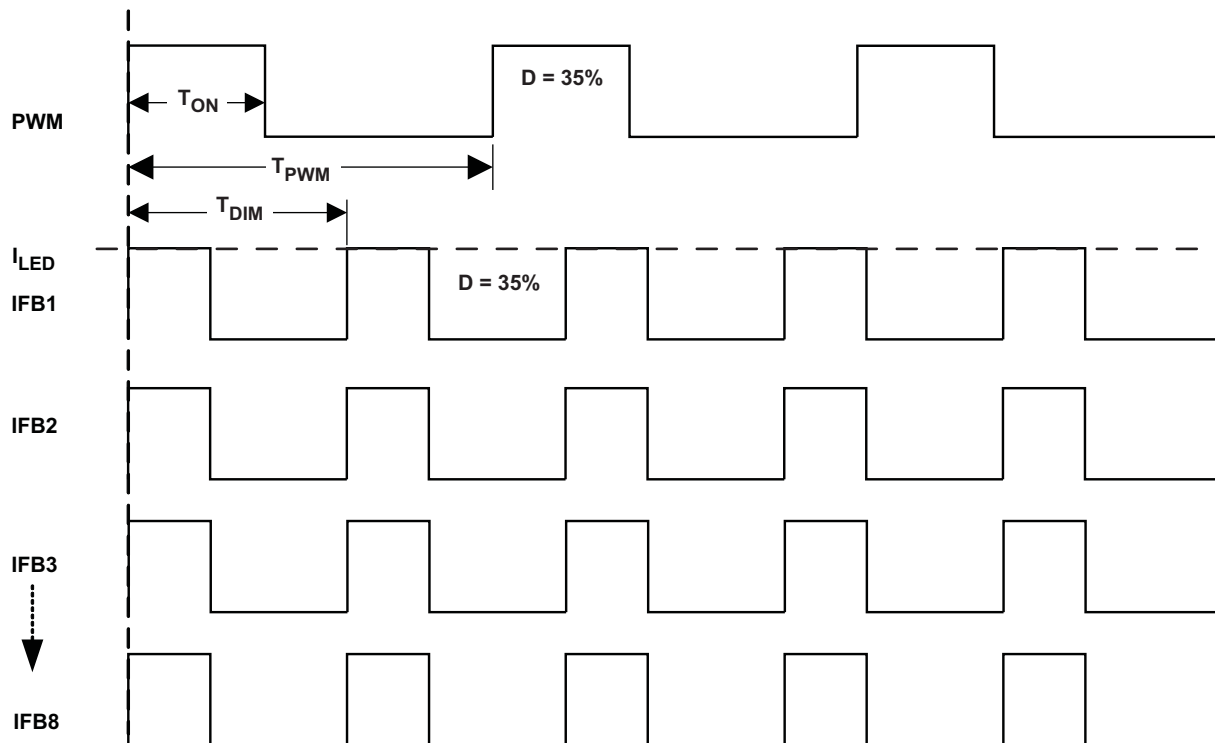

Figure 15. No Delay PWM Dimming Timing Diagram

Table 3 gives the recommended dimming duty cycle range for various input PWM signal frequencies when using No Delay PWM Dimming mode.

Table 3. Recommended Dimming Duty Cycle Range per PWM Frequency when using No Delay PWM Dimming

PWM Input Signal Frequency (Hz)	Dmin(%)	Dmax(%)
100 < f ≤ 200	1	100
200 < f ≤ 500	1	100
500 < f ≤ k	1	100
1k < f ≤ 2k	1	100
2k < f ≤ 5k	1	100
5k < f ≤ 10k	4	100

DIRECT PWM DIMMING

In direct PWM dimming mode, all used IFB channels turn on and off together at the same frequency and duty cycle as the input PWM on the PWM pin. Figure 16 is the timing diagram for direct PWM dimming.

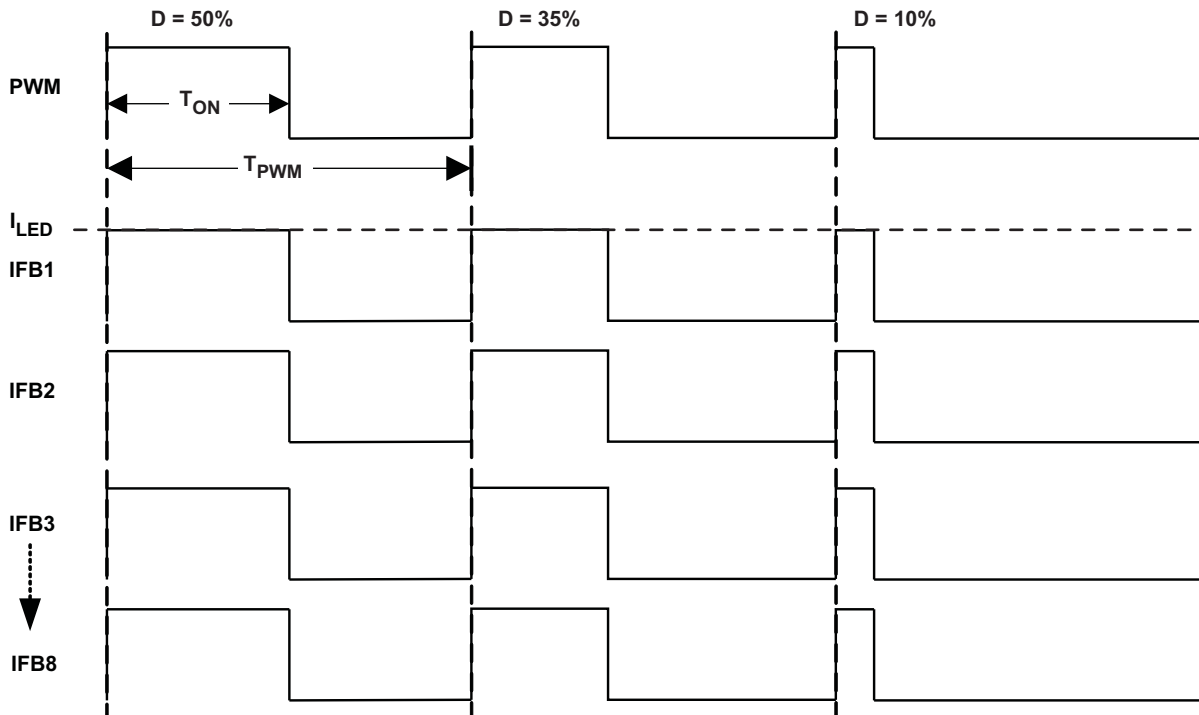

Figure 16. Direct PWM Dimming Timing Diagram

Table 4 gives the recommended input dimming duty cycle range for various input PWM signal frequencies when using Direct PWM Dimming mode.

Table 4. Recommended Dimming Duty Cycle Range per PWM Frequency when using Direct PWM Dimming

PWM Input Signal Frequency (Hz)	Dmin(%)	Dmax(%)
100 < f ≤ 200	0.5	100
200 < f ≤ 500	1	100
500 < f ≤ 1k	1	100

Table 4. Recommended Dimming Duty Cycle Range per PWM Frequency when using Direct PWM Dimming (continued)

PWM Input Signal Frequency (Hz)	Dmin(%)	Dmax(%)
1k < f ≤ 2k	2	100
2k < f ≤ 5k	5	100
5k < f ≤ 10k	10	100
10k < f ≤ 20k	20	100

ANALOG DIMMING

In analog dimming mode, all used current sinks are always on, with each current sink being linearly controlled from 0% to 100% of the maximum IFB current by the duty cycle brightness information stored in the brightness register. Figure 17 shows a simple current diagram of analog dimming mode with PWM brightness control.

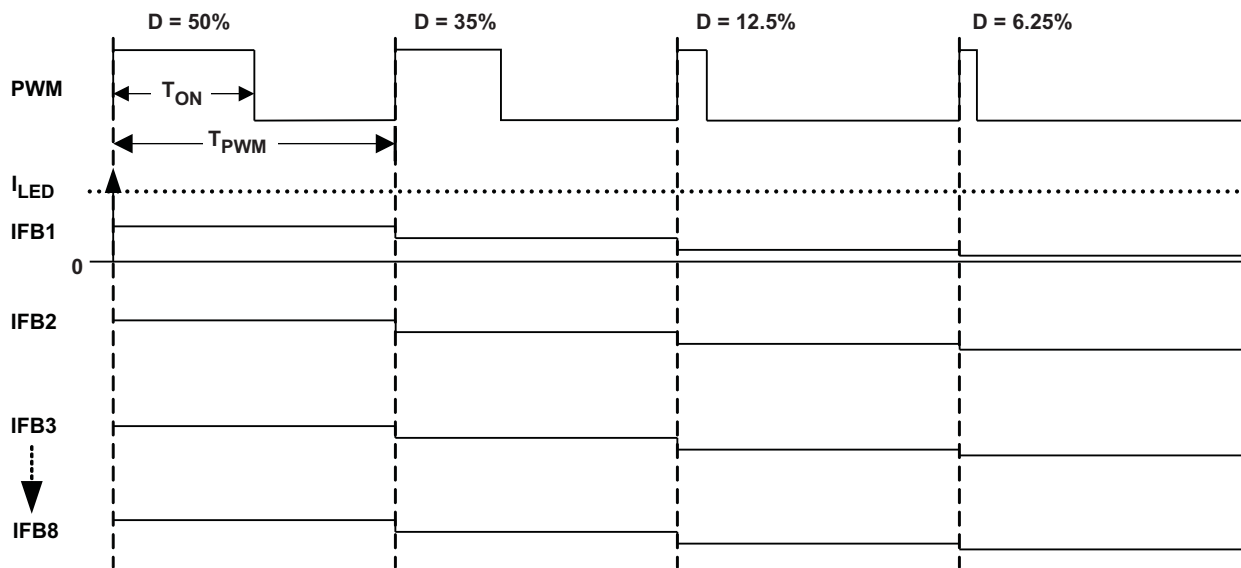

Figure 17. Analog Dimming Timing Diagram

OUTPUT VOLTAGE CLAMP AND OVER VOLTAGE PROTECTION

The TPS61195 has two levels of protection against the output, and therefore the SW pins, exceeding a certain voltage. The output voltage clamp circuit limits the output voltage to the user selected value by limiting the internal feedback loop reference level. The clamp circuit's response time is not fast enough to protect against output voltage transients or high-voltage noise spikes that couple from external circuits. So, if the over-voltage (OV) circuit detects the output going 80mV higher than the clamp voltage, it turns off the boost switch until the output voltage drops below the clamp voltage. Resistors R5 and R6 in the TYPICAL APPLICATION set the output voltage clamp threshold and OV threshold as computed by Equation 5 and Equation 6.

$$V_{OUT_CLAMP} = V_{CLAMP_TH} \times \left(1 + \frac{R5}{R6} \right) \tag{5}$$

$$V_{OUT_OV} = V_{OV_TH} \times \left(1 + \frac{R5}{R6} \right) \tag{6}$$

In the TYPICAL APPLICATION, the output OVP voltage is set to:

$$V_{OUT_CLAMP} = 1.95 \times \left(1 + \frac{1M}{45.3K} \right) = 45 \text{ V} \tag{7}$$

$$V_{OUT_OV} = 2.03 \times \left(1 + \frac{1M}{45.3K}\right) = 46.8 \text{ V} \quad (8)$$

CURRENT SINK OPEN PROTECTION

For the TPS61195, if one of the WLED strings is open, the boost output rises to over-voltage threshold. The IC detects the open WLED string by sensing no current in the corresponding IFB pin. As a result, the IC deactivates the open IFB pin and removes it from the voltage feedback loop. Subsequently, the output voltage drops and is regulated to the minimum voltage required for the connected WLED strings. The IFB current of the connected WLED string remains in regulation during this process.

If any IFB pin voltage exceeds the IFB over-voltage threshold (14V typical), the IC turns off the corresponding current sink and removes this IFB pin from output voltage regulation loop. The remaining IFB pins' current regulation is not affected. This condition often occurs when there are several shorted WLEDs in one string. WLED mismatch typically does not create such large voltage difference among WLED strings.

If the open string is reconnected again, Power-on reset (POR), EN pin toggling or SMBus instruction is required to reactivate a previously deactivated string. The IC will continuously auto-restart if it detects that all of the WLED strings are open until at least one string closes the loop between the boost converter output and one IFB pin.

OVER CURRENT AND SHORT CIRCUIT PROTECTION

The TPS61195 has pulse-by-pulse over-current limit of 2.5A (min). The PWM switch turns off when the inductor current reaches this current threshold. The PWM switch remains off until the beginning of the next switching cycle. This protects the IC and external components under over-load conditions. When there is a sustained over-current condition, the IC turns off and requires POR or the EN pin toggling to restart.

Under severe over-load and/or short circuit conditions, the boost output voltage can be pulled below the required regulated voltage to keep all of the white LEDs operating. Under this condition, the current flows directly from input to output through the inductor and schottky diode. To protect the TPS61195, the device shuts down immediately. The IC restarts after input POR or EN pin logic toggling or SMBus instruction.

THERMAL PROTECTION

When the junction temperature of the TPS61195 is over 150°C (typ), the thermal protection circuit is triggered and shuts down the device immediately. The device automatically restarts when the junction temperature is back to less than 150°C with about 15°C hysteresis.

SMBUS INTERFACE CONTROL

TPS61195 can be controlled by the SMBus if selected by the mode pin SEL1. The TPS61195 includes four registers to control and monitor the brightness, fault status, operating mode and identification. The slave address of the device has 7 fixed bits and 1 read or write bit as Figure 18 shows. If the device is requested to read, the R/W bit is set to 1, otherwise the R/W bit is set to 0.

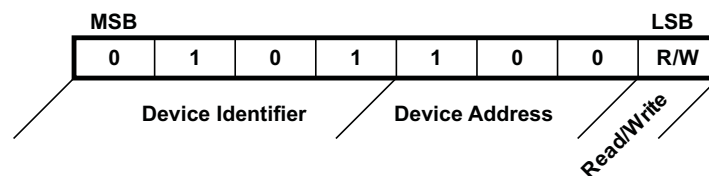

Figure 18. TPS61195 Slave Address

READ BYTE

As shown in Figure 19, the four byte long Read Byte protocol starts with the slave address followed by the "command code" which translates to the "register index". Then the bus direction turns around with the re-broadcast of the slave address with bit 0 indicating a read cycle. The fourth byte contains the data being returned by the backlight controller. That byte value in the data byte should reflect the value of the register being queried at the "command code" index. A dark grey outline is used on cycles during which the backlight controller "owns" or "drives" the Data line. All other cycles are driven by the "host".

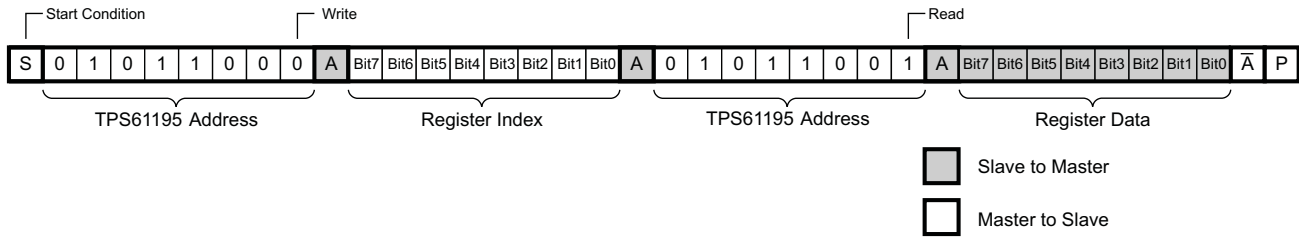

Figure 19. TPS61195 SMBus Read Byte Protocol

WRITE BYTE

The Write Byte protocol is only three bytes long. The first byte starts with the slave address again followed by the "command code" which translates to the "register index" being written. The third byte contains the data byte that must be written into the register selected by the "command code". Again note the bus directions as highlighted by the dark grey outline.

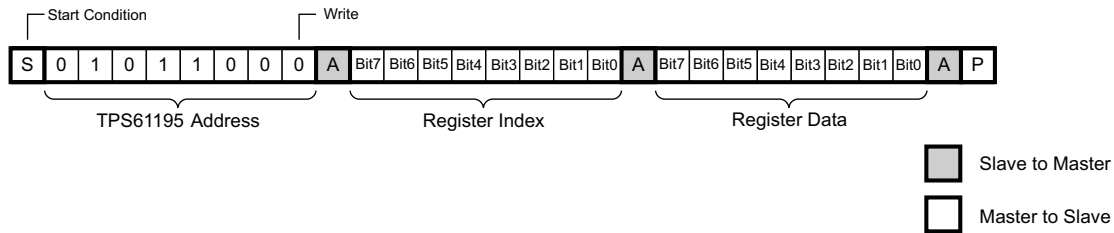

Figure 20. TPS61195 SMBus Write Byte Protocol

SMBUS REGISTER DESCRIPTION

All backlight controller registers are one byte wide and accessible via the Read/Write Byte protocols. Their bit assignments are provided in the following sections with reserved bits containing a default value of "0".

Brightness Control Register (0x00)

This register is both readable and writable with one byte length, BRT0~BRT7 which could be used to control the white LED brightness level in 255 steps. In SMBus control mode, a SMBus write cycle to register 0x00 sets the brightness level. Setting this register to 0xFF implements the maximum brightness output, while setting the value to 0x00 sets the brightness output to 0% of maximum brightness. The default value of this register is 0xFF. The register returns the current brightness level in the register read cycle.

REGISTER 0x00		BRIGHTNESS CONTROL REGISTER			DEFAULT 0xFF		
BRT7	BRT6	BRT5	BRT4	BRT3	BRT2	BRT1	BRT0
Bit 7 (R/W)	Bit 6 (R/W)	Bit 5 (R/W)	Bit 4 (R/W)	Bit 3 (R/W)	Bit 2 (R/W)	Bit 1 (R/W)	Bit 0 (R/W)

Bit field definitions:

BRT[7..0]	256 steps of brightness level
------------------	-------------------------------

Backlighting Control Register (0x01)

This register has two bits, PWM_MD and PWM_SEL that control the operating mode of the backlight controller, and a single bit that controls the BL ON/OFF state. The remaining bits are reserved for future use. The register is both readable and writable. In a read cycle, Bit 0, 1 and 2 return the operating mode code and Bit 3 to 7 return zero. Writing a value to Bit 1 and 2 sets the operating mode while a write value 1 or 0 to Bit 0 will turn ON and OFF the current sinks respectively.

REGISTER 0x01			BACKLIGHTING CONTROL REGISTER			DEFAULT VALUE 0x00	
Reserved	Reserved	Reserved	Reserved	Reserved	PWM_MD	PWM_SEL	BL_CTL
Bit 7	Bit	Bit 5	Bit 4	Bit 3	Bit 2 (R/W)	Bit 1 (R/W)	Bit 0 (R/W)

Bit field definitions:

PWM_MD	PWM mode select (1 = absolute brightness, 0 = % change) default = 0
PWM_SEL	Brightness MUX select (1 = PWM pin, 0 = SMBus value) default = 0
BL_CTL	BL On/Off (1 = On, 0 = Off) default = 0

Operating mode selected by backlighting control register bit 1 and bit 2:

PWM_MD	PWM_SEL	MODE	DESCRIPTION
X	1	PWM mode	The brightness is determined by PWM input duty cycle only
1	0	SMBus mode	The brightness is set by SMBus command only
b	0	DPST mode	The brightness is the product of SMBus command and PWM input duty cycle

Fault/status Register (0x02)

This register has six status bits that allow monitoring of the backlight controller's operating state. Bit 0 is a logical "OR" of all fault codes to simplify error detection. Bit 3 is a simple BL status indicator. Bit 6 and bit 7 are reserved for future use. All reserved bits return zero when read and ignore the bit value when written. All of the bits in this register are read-only.

REGISTER 0x02			FAULT STATUS REGISTER			DEFAULT VALUE 0x00	
RESERVED	RESERVED	2_CH_EN	1_CH_EN	BL_STAT	OV_CURR	THRM_SHDN	FAULT
Bit 7	Bit 6	Bit 5 (R)	Bit 4 (R)	Bit 3 (R)	Bit 2 (R)	Bit 1 (R)	Bit 0 (R)

Bit field definitions:

2_CH_EN	The number of faulted strings is reported in bits 5 and 4.
1_CH_EN	(00 = No faults, 01 = One string fault, 11 = Two or more strings faulted)
BL_STAT	BL status (1 = BL On, 0 = BL Off)
OV_CURR	Input over-current (1 = Over-current condition, 0 = Current OK)
THRM_SHDN	Thermal Shutdown (1 = Thermal fault, 0 = Thermal OK)
FAULT	Any fault except LED open and short occurs (Logic "OR" of all the fault conditions)

Identification Register (0x03)

The ID register contains two bit fields to denote the manufacturer and the silicon revision of the device. The bit field widths were chosen to allow up to 32 vendors with up to eight silicon revisions each. This register is read-only.

REGISTER 0x03		IDENTIFICATION REGISTER				DEFAULT VALUE 0xA0		
LED PANEL	MFG3	MFG2	MFG1	MFG0	REV2	REV1	REV0	
Bit 7=1	Bit 6 (R)	Bit 5 (R)	Bit 4 (R)	Bit 3 (R)	Bit 2 (R)	Bit 1 (R)	Bit 0 (R)	

Bit field definitions:

LED PANEL	Display panel use white LED backlighting = 1
MFG[3..0]	Manufacturer ID (16 Vendor IDs to be specified by Dell) See Table 5
REV[2..0]	Silicon rev (Revs 0-7 allowed for silicon spins)

Table 5. Vendor IDs List

ID	Vendor
0	Maxim
1	Micro Semi
2	MPS
3	O2 Micro
4	TI
5	ST
6	Analog Devices
7	Taos
8	Toko
9	Rohm
10	Oki
11	Allegro
12	Semtech
13	Intersil
14	Reserved
15	Vendor ID register not implemented

APPLICATION INFORMATION

INDUCTOR SELECTION

Because the selection of the inductor affects power supply's steady state operation, transient behavior and loop stability, the inductor is the most important component in switching power regulator design. There are three specifications most important to the performance of the inductor, inductor value, DC resistance and saturation current. The TPS61195 is designed to work with inductor values between 4.7μH and 10μH. A 4.7μH inductor are typically available in a smaller or lower profile package, while a 10μH inductor may produce higher efficiency due to slower switching frequency and/or lower inductor ripple. If the boost output current is limited by the over-current protection of the IC, using a 10μH inductor and highest switching frequency maximizes the controller's output current capability.

The internal loop compensation for the PWM control is optimized for the external component values including typical tolerances (refer to [RECOMMENDED OPERATING CONDITIONS](#)). RECOMMENDED OPERATING CONDITIONS inductor values can have ±20% tolerance with no current bias. When the inductor current approaches saturation level, its inductance can decrease 20% to 35% from the 0A value depending on how the inductor vendor defines saturation.

In a boost regulator, the inductor DC current can be calculated as:

$$I_{dc} = \frac{V_{out} \times I_{out}}{V_{in} \times \eta} \quad (9)$$

Where

V_{out} = boost output voltage

I_{out} = boost output current

V_{in} = boost input voltage

η = power conversion efficiency, use 90% for TPS61195 applications

The inductor current peak to peak ripple can be calculated as:

$$I_{pp} = \frac{1}{L \times \left(\frac{1}{V_{out} - V_{in}} + \frac{1}{V_{in}} \right)} \times F_s \quad (10)$$

Where

I_{pp} = inductor peak to peak ripple

L = inductor value

F_s = switching frequency

V_{out} = boost output voltage

V_{in} = boost input

Therefore, the peak current seen by the inductor is:

$$I_p = I_{dc} + \frac{I_{pp}}{2} \quad (11)$$

Select the inductor with saturation current at least 30% higher than the calculated peak current to account for the load transient steps that occur during startup and dimming. To calculate the worst case inductor peak current, use minimum input voltage, maximum output voltage and maximum load current.

Regulator efficiency is dependent on the resistance of its high current path and switching losses associated with the PWM switch and power diode. Although the TPS61195 IC has optimized the internal switch resistance, the overall efficiency is affected by the inductor's DC resistance (DCR); Lower DCR improves efficiency. However, there is a trade off between DCR and inductor footprint, furthermore, shielded inductors typically have higher DCR than unshielded ones. [Table 6](#) lists recommended inductor models.

Table 6. Recommended Inductor for TPS61195

	L (μH)	DCR (mΩ)	Isat (A)	Size (LxWxH mm)
TOKO				
A915AY-4R7M	4.7	38	1.87	5.2 × 5.2 × 3.0
A915AY-100M	10	75	1.24	5.2 × 5.2 × 3.0
TDK				
SLF6028T-4R7N1R6	4.7	28.4	1.6	6.0 × 6.0 × 2.8
SLF6028T-100M1R3	10	53.2	1.3	6.0 × 6.0 × 2.8

OUTPUT CAPACITOR SELECTION

The output capacitor is mainly selected to meet the requirement for the output ripple and loop stability. This ripple voltage is related to the capacitor's capacitance and its equivalent series resistance (ESR). Assuming a capacitor with zero ESR, the minimum capacitance needed for a given ripple can be calculated by:

$$C_{out} = \frac{(V_{out} - V_{in}) \times I_{out}}{V_{out} \times F_{boost} \times V_{ripple}} \quad (12)$$

Where,

V_{ripple} = peak to peak output ripple. The additional part of ripple caused by the ESR is calculated using:

$$V_{ripple_ESR} = I_{out} \times R_{ESR}$$

Due to its low ESR, V_{ripple_ESR} may be neglected for ceramic capacitor, but must be considered if tantalum or electrolytic capacitors are used.

The controller's output voltage also ripples due to the load transient that occurs during PWM dimming. The TPS61195 adopts a patented technology to limit this type of output ripple even with the minimum recommended output capacitance. In a typical application, the output ripple is less than 250mV during PWM dimming with 4.7μF output capacitor. However, the output ripple decreases with higher output capacitances. An output capacitance value in the range of 4.7μF to 10μF is required for loop stability.

LAYOUT CONSIDERATION

As for all switching power supplies, especially those providing high current and using high switching frequencies, layout is an important design step. If layout is not carefully done, the regulator could show instability as well as EMI problems. Therefore, use wide and short traces for high current paths. The input capacitor, C4 in the [TYPICAL APPLICATION](#), needs not only to be close to the V_{IN} pin, but also to the GND pin in order to reduce the input ripple seen by the IC. The input capacitor, C1 in the typical application circuit, should also be placed close to the inductor. C2 is the filter and noise decoupling capacitor for internal linear regulator powering the internal digital circuits. It should be placed as close as possible between the VDDIO and AGND pins to prevent any noise insert to digital circuits. The SW pin carries high current with fast rising and falling edges. Therefore, the connection between the pin to the inductor and Schottky should be kept as short and wide as possible. It is also beneficial to have the ground of the output capacitor C3 close to the PGND pin since there is large ground return current flowing through it. When laying out signal ground, it is recommended to use short traces separated from power ground traces, and connect them together at a single point, for example on the thermal pad.

R1 in the Typical Application Circuit is current setting resistor connect to the ISET pin. To avoid unexpected noise coupling into the ISET pin and affecting the IFB current stability, R1 needs to be close to the ISET pin and AGND pins with short and wide trace.

Thermal pad needs to be soldered on to the PCB and connected to the GND pins of the IC. Additional thermal vias can significantly improve power dissipation of the IC. Specially, at low input voltage and high power output conditions, the large PCB area and more layers PCB design for thermal dissipation must be considered.

TYPICAL APPLICATION CIRCUITS

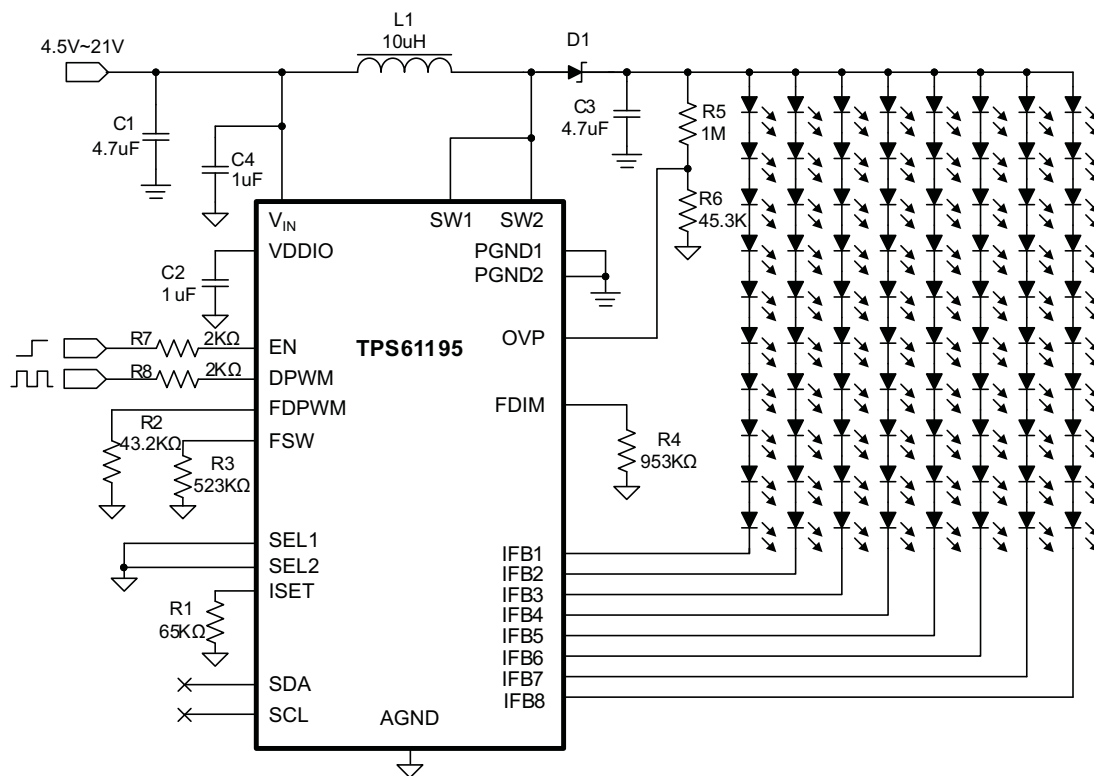

Figure 21. Typical Application Circuit With PWM Control Direct PWM Dimming Configuration

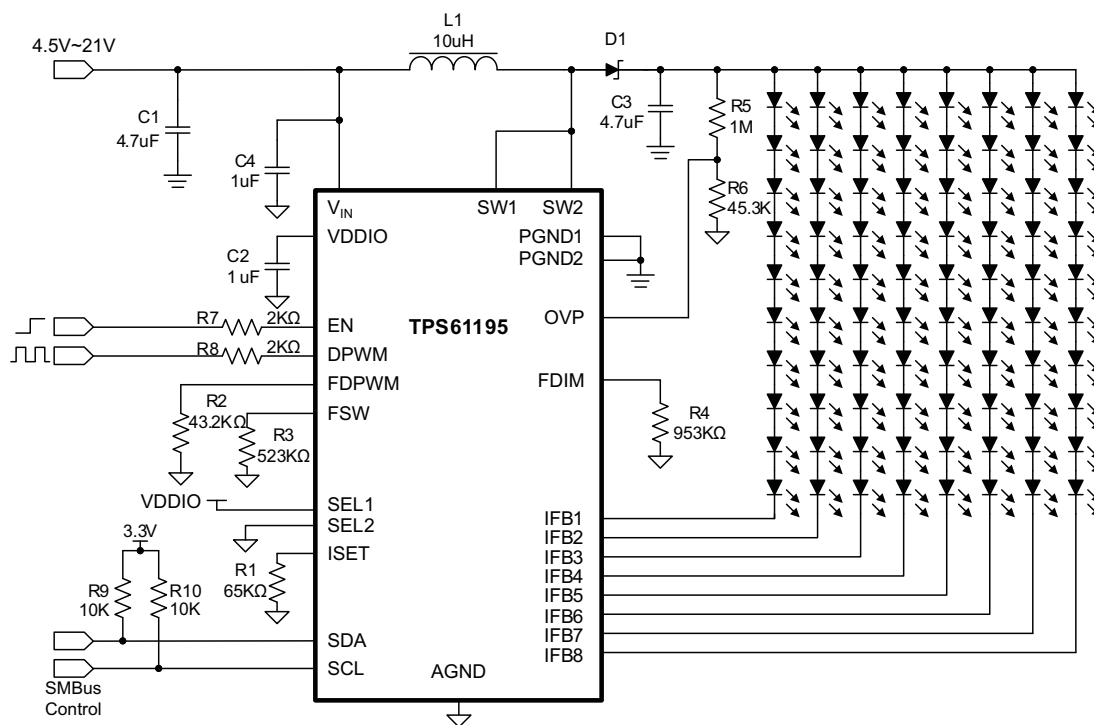

Figure 22. Typical Application Circuit for SMBus Control interface with Internal Frequency PWM Dimming Setting

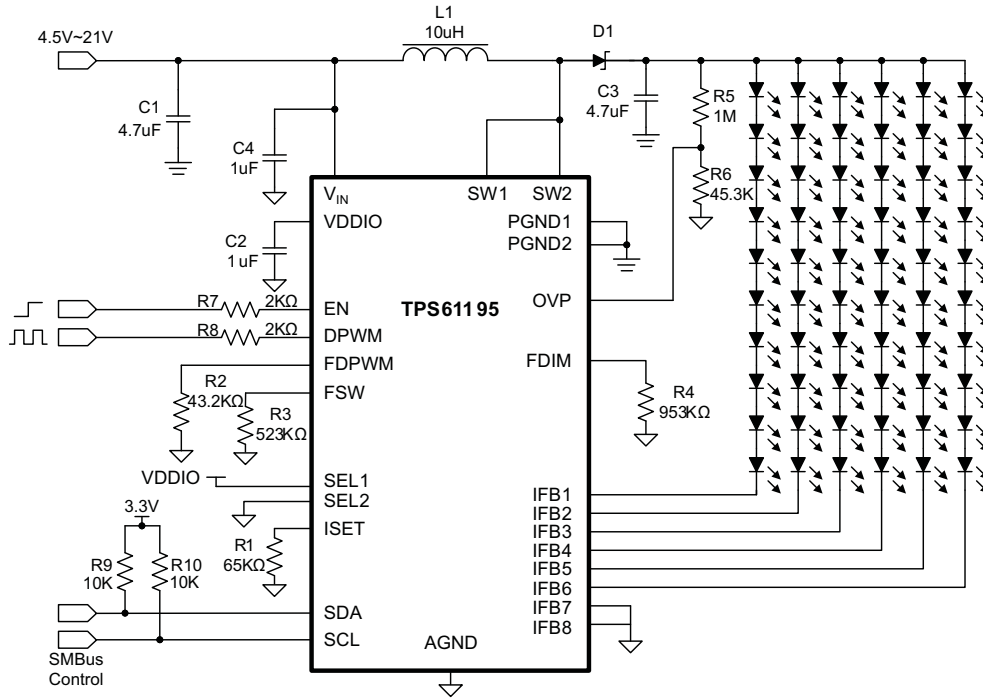

Figure 23. Typical Application Circuit for SMBus Control interface and 6 Strings LED

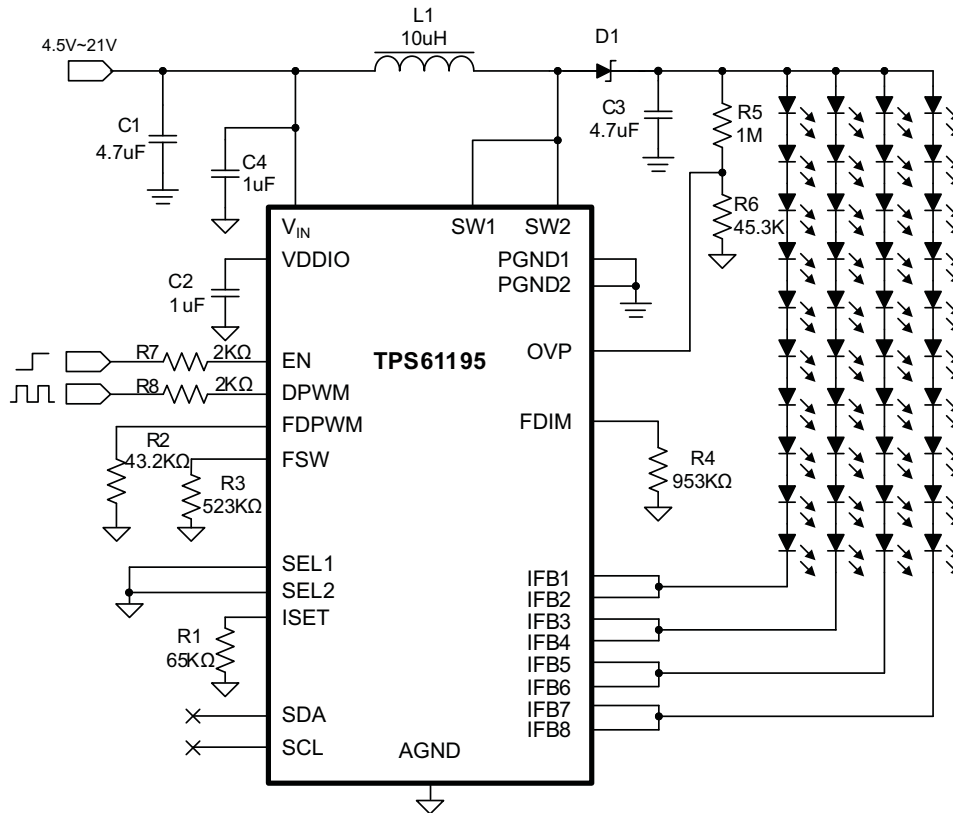



Figure 24. Typical Application Circuit for 4 Strings 40mA LED

PACKAGING INFORMATION

Orderable Device	Status (1)	Package Type	Package Drawing	Pins	Package Qty	Eco Plan (2)	Lead finish/ Ball material (6)	MSL Peak Temp (3)	Op Temp (°C)	Device Marking (4/5)	Samples
TPS61195RUJR	ACTIVE	WQFN	RUY	28	3000	RoHS & Green	NIPDAU	Level-2-260C-1 YEAR	-40 to 85	TPS 61195	
TPS61195RUJT	ACTIVE	WQFN	RUY	28	250	RoHS & Green	NIPDAU	Level-2-260C-1 YEAR	-40 to 85	TPS 61195	

(1) The marketing status values are defined as follows:

ACTIVE: Product device recommended for new designs.

LIFEBUY: TI has announced that the device will be discontinued, and a lifetime-buy period is in effect.

NRND: Not recommended for new designs. Device is in production to support existing customers, but TI does not recommend using this part in a new design.

PREVIEW: Device has been announced but is not in production. Samples may or may not be available.

OBSOLETE: TI has discontinued the production of the device.

(2) **RoHS:** TI defines "RoHS" to mean semiconductor products that are compliant with the current EU RoHS requirements for all 10 RoHS substances, including the requirement that RoHS substance do not exceed 0.1% by weight in homogeneous materials. Where designed to be soldered at high temperatures, "RoHS" products are suitable for use in specified lead-free processes. TI may reference these types of products as "Pb-Free".

RoHS Exempt: TI defines "RoHS Exempt" to mean products that contain lead but are compliant with EU RoHS pursuant to a specific EU RoHS exemption.

Green: TI defines "Green" to mean the content of Chlorine (Cl) and Bromine (Br) based flame retardants meet JS709B low halogen requirements of <=1000ppm threshold. Antimony trioxide based flame retardants must also meet the <=1000ppm threshold requirement.

(3) MSL, Peak Temp. - The Moisture Sensitivity Level rating according to the JEDEC industry standard classifications, and peak solder temperature.

(4) There may be additional marking, which relates to the logo, the lot trace code information, or the environmental category on the device.

(5) Multiple Device Markings will be inside parentheses. Only one Device Marking contained in parentheses and separated by a "~" will appear on a device. If a line is indented then it is a continuation of the previous line and the two combined represent the entire Device Marking for that device.

(6) Lead finish/Ball material - Orderable Devices may have multiple material finish options. Finish options are separated by a vertical ruled line. Lead finish/Ball material values may wrap to two lines if the finish value exceeds the maximum column width.

Important Information and Disclaimer:The information provided on this page represents TI's knowledge and belief as of the date that it is provided. TI bases its knowledge and belief on information provided by third parties, and makes no representation or warranty as to the accuracy of such information. Efforts are underway to better integrate information from third parties. TI has taken and continues to take reasonable steps to provide representative and accurate information but may not have conducted destructive testing or chemical analysis on incoming materials and chemicals. TI and TI suppliers consider certain information to be proprietary, and thus CAS numbers and other limited information may not be available for release.

In no event shall TI's liability arising out of such information exceed the total purchase price of the TI part(s) at issue in this document sold by TI to Customer on an annual basis.

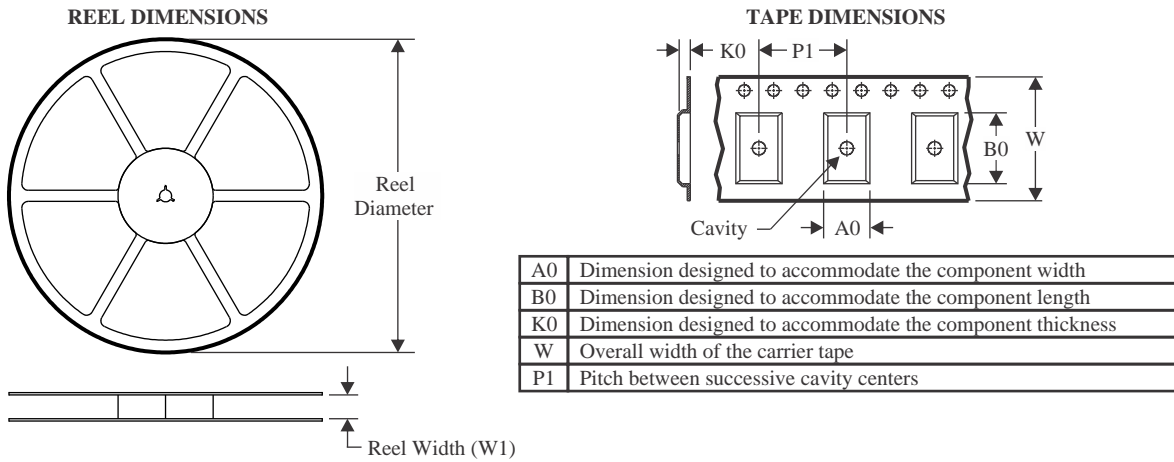
TAPE AND REEL INFORMATION

QUADRANT ASSIGNMENTS FOR PIN 1 ORIENTATION IN TAPE



*All dimensions are nominal

Device	Package Type	Package Drawing	Pins	SPQ	Reel Diameter (mm)	Reel Width W1 (mm)	A0 (mm)	B0 (mm)	K0 (mm)	P1 (mm)	W (mm)	Pin1 Quadrant
TPS61195RUYR	WQFN	RUY	28	3000	330.0	12.4	4.25	4.25	1.15	8.0	12.0	Q2
TPS61195RUYT	WQFN	RUY	28	250	180.0	12.4	4.25	4.25	1.15	8.0	12.0	Q2

TAPE AND REEL BOX DIMENSIONS

*All dimensions are nominal

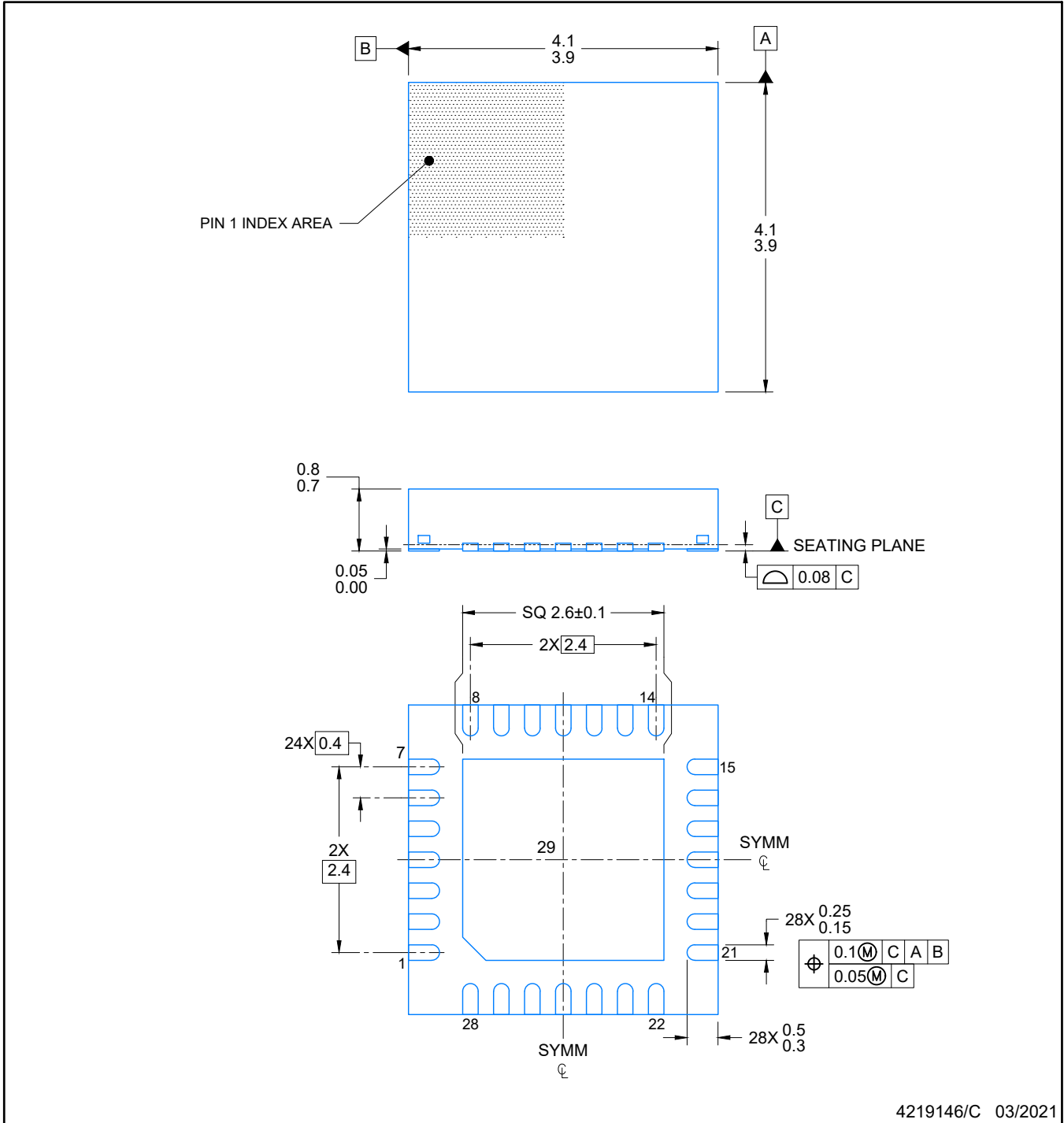
Device	Package Type	Package Drawing	Pins	SPQ	Length (mm)	Width (mm)	Height (mm)
TPS61195RUYR	WQFN	RUY	28	3000	356.0	356.0	35.0
TPS61195RUYT	WQFN	RUY	28	250	210.0	185.0	35.0



NOTES:

1. All linear dimensions are in millimeters. Any dimensions in parenthesis are for reference only. Dimensioning and tolerancing per ASME Y14.5M.
2. This drawing is subject to change without notice.
3. The package thermal pad must be soldered to the printed circuit board for optimal thermal and mechanical performance.

EXAMPLE STENCIL DESIGN

RUY0028A

WQFN - 0.8 mm max height

PLASTIC QUAD FLATPACK-NO LEAD

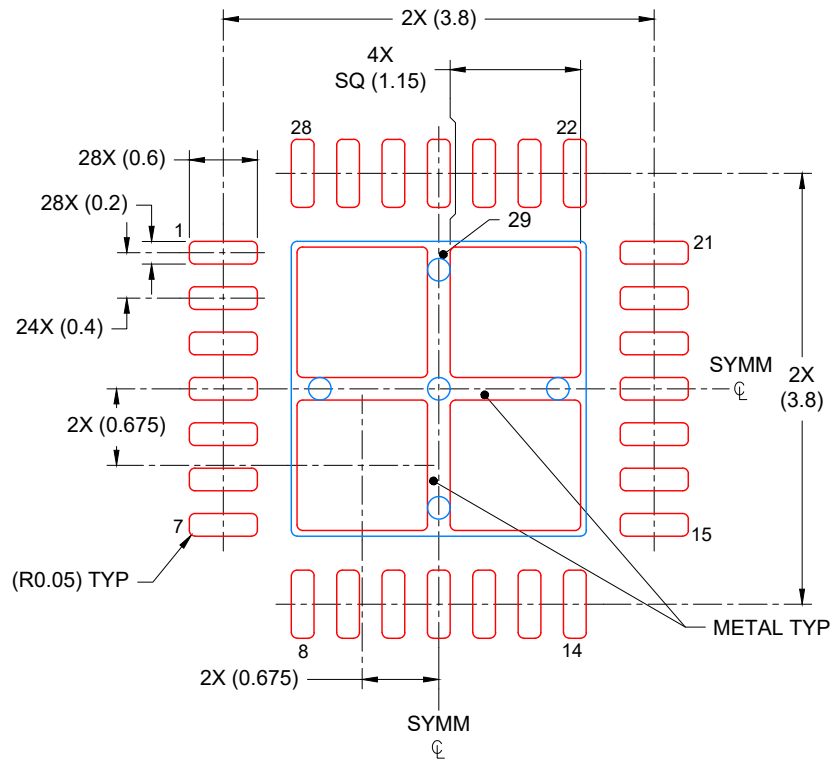

SOLDER PASTE EXAMPLE
BASED ON 0.125 mm THICK STENCIL

EXPOSED PAD
78% PRINTED COVERAGE BY AREA
SCALE: 15X

4219146/C 03/2021

NOTES: (continued)

6. Laser cutting apertures with trapezoidal walls and rounded corners may offer better paste release. IPC-7525 may have alternate design recommendations.

IMPORTANT NOTICE AND DISCLAIMER

TI PROVIDES TECHNICAL AND RELIABILITY DATA (INCLUDING DATA SHEETS), DESIGN RESOURCES (INCLUDING REFERENCE DESIGNS), APPLICATION OR OTHER DESIGN ADVICE, WEB TOOLS, SAFETY INFORMATION, AND OTHER RESOURCES "AS IS" AND WITH ALL FAULTS, AND DISCLAIMS ALL WARRANTIES, EXPRESS AND IMPLIED, INCLUDING WITHOUT LIMITATION ANY IMPLIED WARRANTIES OF MERCHANTABILITY, FITNESS FOR A PARTICULAR PURPOSE OR NON-INFRINGEMENT OF THIRD PARTY INTELLECTUAL PROPERTY RIGHTS.

These resources are intended for skilled developers designing with TI products. You are solely responsible for (1) selecting the appropriate TI products for your application, (2) designing, validating and testing your application, and (3) ensuring your application meets applicable standards, and any other safety, security, regulatory or other requirements.

These resources are subject to change without notice. TI grants you permission to use these resources only for development of an application that uses the TI products described in the resource. Other reproduction and display of these resources is prohibited. No license is granted to any other TI intellectual property right or to any third party intellectual property right. TI disclaims responsibility for, and you will fully indemnify TI and its representatives against, any claims, damages, costs, losses, and liabilities arising out of your use of these resources.

TI's products are provided subject to [TI's Terms of Sale](#) or other applicable terms available either on ti.com or provided in conjunction with such TI products. TI's provision of these resources does not expand or otherwise alter TI's applicable warranties or warranty disclaimers for TI products.

TI objects to and rejects any additional or different terms you may have proposed.

Mailing Address: Texas Instruments, Post Office Box 655303, Dallas, Texas 75265
Copyright © 2022, Texas Instruments Incorporated

Looking for pricing, stock, or lifecycle information?

Click below to explore more details on WIN SOURCE:

 [View TPS61195EVM-460 on WIN SOURCE](#)

 [Texas Instruments](#) Information

Optimize Your Supply Chain with WIN SOURCE Solutions

-  Global Sourcing Solution
-  Obsolete Management
-  Cost Control Management
-  Shortage Management
-  Alternative Solution
-  Excess Inventory Management