



# THE DATASHEET OF TPS3702CX12DDCT



# TPS3702 High-Accuracy Over and Undervoltage Monitoring

## 1 Features

- Input Voltage Range: 2V to 18V
- High threshold accuracy:
  - 0.25% (typical)
  - 0.9% (–40°C to 125°C)
- Fixed window thresholds optimized for nominal rails between 1V and 5V
- Open-drain outputs for overvoltage and undervoltage indication
- Internal glitch immunity
- Threshold adjust using the SET pin
- Low quiescent current: 7 $\mu$ A (typical)
- Internal threshold hysteresis: 0.55%, 1.0%
- SOT-6 package

## 2 Applications

- [FPGA and ASIC applications](#)
- [DSP-based systems](#)
- [Industrial control systems](#)
- [Factory automation](#)
- [Personal electronics](#)
- [Building automation](#)
- [Motor drives](#)

## 3 Description

The TPS3702 is an integrated overvoltage and undervoltage window voltage detector in a small SOT-6 package. This highly accurate voltage detector is an excellent choice for systems that operate on low-voltage supply rails and have narrow margin supply tolerances. Low threshold hysteresis options of 0.55% and 1.0% prevent false reset signals when the monitored voltage supply is in the normal range of operation. Internal glitch immunity and noise filters further eliminate false resets resulting from erroneous signals.

The TPS3702 does not require any external resistors for setting overvoltage and undervoltage reset thresholds, which further increases overall accuracy and reduces solution size and cost. The SET pin is used to select between the two available threshold voltages designed into each device. A separate SENSE input pin and VDD pin allow for the redundancy sought by safety-critical and high-reliability systems. This device also features independent reset outputs for the OV and UV pins; as a result of the open-drain configuration, UV and OV can be tied together.

This device has a low typical quiescent current specification of 7 $\mu$ A and is qualified for use over the industrial temperature range of –40°C to 125°C.

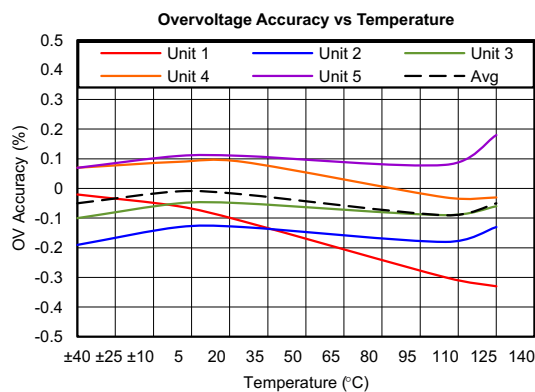
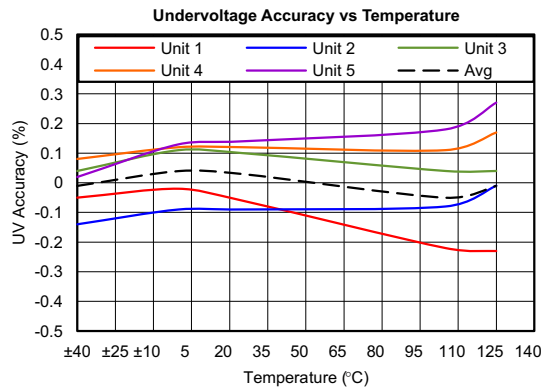

**Accuracy versus Temperature**

### Device Information

PART NUMBER	PACKAGE (1)	BODY SIZE (NOM) (2)
TPS3702	SOT (6)	2.90mm × 1.60mm

- (1) For all available packages, see the orderable addendum at the end of the data sheet.
- (2) The package size (length × width) is a nominal value and includes pins, where applicable.

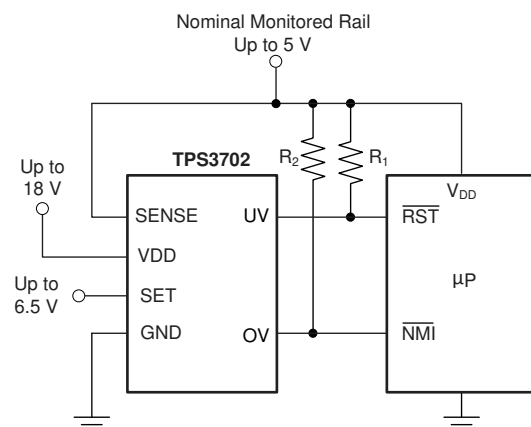

**Typical Application Circuit**



## Table of Contents

<b>1 Features</b> .....	<b>1</b>	<b>7 Application and Implementation</b> .....	<b>13</b>
<b>2 Applications</b> .....	<b>1</b>	7.1 Application Information.....	13
<b>3 Description</b> .....	<b>1</b>	7.2 Typical Application.....	17
<b>4 Pin Configuration and Functions</b> .....	<b>3</b>	<b>8 Power Supply Recommendations</b> .....	<b>19</b>
<b>5 Specifications</b> .....	<b>4</b>	<b>9 Layout</b> .....	<b>20</b>
5.1 Absolute Maximum Ratings.....	4	9.1 Layout Guidelines.....	20
5.2 ESD Ratings.....	4	9.2 Layout Example.....	20
5.3 Recommended Operating Conditions.....	4	<b>10 Device and Documentation Support</b> .....	<b>21</b>
5.4 Thermal Information.....	4	10.1 Device Support.....	21
5.5 Electrical Characteristics.....	5	10.2 Documentation Support.....	22
5.6 Timing Requirements.....	6	10.3 Support Resources.....	22
5.7 Typical Characteristics.....	7	10.4 Trademarks.....	22
<b>6 Detailed Description</b> .....	<b>10</b>	10.5 Electrostatic Discharge Caution.....	22
6.1 Overview.....	10	10.6 Glossary.....	22
6.2 Functional Block Diagram.....	10	<b>11 Revision History</b> .....	<b>22</b>
6.3 Feature Description.....	11	<b>12 Mechanical, Packaging, and Orderable Information</b> .....	<b>22</b>
6.4 Device Functional Modes.....	12		

## 4 Pin Configuration and Functions

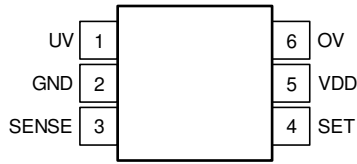

**Figure 4-1. DDC Package  
SOT-6  
Top View**

**Table 4-1. Pin Functions**

PIN		I/O	DESCRIPTION
NO.	NAME		
1	UV	O	Active-low, open-drain undervoltage output. This pin goes low when the SENSE voltage falls below the internally set undervoltage threshold ( $V_{IT-}$ ). See the timing diagram in <a href="#">Figure 5-1</a> for more details. Connect this pin to a pull-up resistor terminated to the desired pull-up voltage.
2	GND	—	Ground
3	SENSE	I	Input for the monitored supply voltage rail. When the SENSE voltage goes below the undervoltage threshold, the UV pin is driven low. When the SENSE voltage goes above the overvoltage threshold, the OV pin is driven low.
4	SET	I	Use this pin to configure the threshold voltages. Refer to <a href="#">Table 10-1</a> for the desired configuration.
5	VDD	I	Supply voltage input pin. To power the device, connect a voltage supply (within the range of 2V and 18V) to VDD. Good analog design practice is to place a 0.1µF ceramic capacitor close to this pin.
6	OV	O	Active-low, open-drain overvoltage output. This pin goes low when the SENSE voltage rises above the internally set overvoltage threshold ( $V_{IT+}$ ). See the timing diagram in <a href="#">Figure 5-1</a> for more details. Connect this pin to a pull-up resistor terminated to the desired pull-up voltage.

## 5 Specifications

### 5.1 Absolute Maximum Ratings

over operating free-air temperature range (unless otherwise noted)<sup>(1)</sup>

		MIN	MAX	UNIT
Voltage	V <sub>DD</sub>	-0.3	20	V
	V <sub>UV</sub> , V <sub>OV</sub>	-0.3	20	V
	V <sub>SENSE</sub> , V <sub>SET</sub>	-0.3	7	V
Current	I <sub>UV</sub> , I <sub>OV</sub>		±40	mA
Continuous total power dissipation		See the <a href="#">Section 5.4</a>		
Operating junction temperature, T <sub>J</sub> <sup>(2)</sup>		-40	125	°C
Storage temperature, T <sub>stg</sub>		-65	150	°C

- (1) Stresses beyond those listed under *Absolute Maximum Ratings* may cause permanent damage to the device. These are stress ratings only, which do not imply functional operation of the device at these or any other conditions beyond those indicated under *Recommended Operating Conditions*. Exposure to absolute-maximum-rated conditions for extended periods may affect device reliability.
- (2) As a result of the low dissipated power in this device, it is assumed that T<sub>J</sub> = T<sub>A</sub>.

### 5.2 ESD Ratings

		VALUE	UNIT
V <sub>(ESD)</sub> Electrostatic discharge	Human body model (HBM), per ANSI/ESDA/JEDEC JS-001 <sup>(1)</sup>	±2000	V
	Charged device model (CDM), per JEDEC specification JESD22-C101 <sup>(2)</sup>	±750	

- (1) JEDEC document JEP155 states that 500V HBM allows safe manufacturing with a standard ESD control process.
- (2) JEDEC document JEP157 states that 250V CDM allows safe manufacturing with a standard ESD control process.

### 5.3 Recommended Operating Conditions

over operating free-air temperature range (unless otherwise noted)

		MIN	NOM	MAX	UNIT
V <sub>DD</sub>	Supply pin voltage	2		18	V
V <sub>SENSE</sub>	Input pin voltage	0		6.5	V
V <sub>SET</sub>	SET pin voltage	0		6.5	V
V <sub>UV</sub> , V <sub>OV</sub>	Output pin voltage	0		18	V
I <sub>UV</sub> , I <sub>OV</sub>	Output pin current	0.3		10	mA
R <sub>PU</sub>	Pull-up resistor	2.2		10,000	kΩ

### 5.4 Thermal Information

THERMAL METRIC <sup>(1)</sup>		TPS3702	UNIT
		DDC (SOT)	
		6 PINS	
R <sub>θJA</sub>	Junction-to-ambient thermal resistance	201.6	°C/W
R <sub>θJC(top)</sub>	Junction-to-case (top) thermal resistance	47.8	°C/W
R <sub>θJB</sub>	Junction-to-board thermal resistance	51.2	°C/W
ψ <sub>JT</sub>	Junction-to-top characterization parameter	0.7	°C/W
ψ <sub>JB</sub>	Junction-to-board characterization parameter	50.8	°C/W
R <sub>θJC(bot)</sub>	Junction-to-case (bottom) thermal resistance	N/A	°C/W

- (1) For more information about traditional and new thermal metrics, see the *IC Package Thermal Metrics* application report, [SPRA953](#).

## 5.5 Electrical Characteristics

At  $2V \leq V_{DD} \leq 18V$ ,  $1V \leq V_{SENSE} \leq 5V$ , and over the operating free-air temperature range of  $-40^{\circ}C$  to  $125^{\circ}C$ , unless otherwise noted. Typical values are at  $T_J = 25^{\circ}C$ .

PARAMETER		TEST CONDITIONS	MIN	TYP	MAX	UNIT
$V_{DD}$	Supply voltage range		2		18	V
$V_{IT+(OV)}$	Positive-going threshold accuracy	$V_{SET} \leq V_{IL(SET)}$ , $V_{SET} \geq V_{IH(SET)}$	-0.9%	$\pm 0.25\%$	0.9%	
$V_{IT-(UV)}$	Negative-going threshold accuracy	$V_{SET} \leq V_{IL(SET)}$ , $V_{SET} \geq V_{IH(SET)}$	-0.9%	$\pm 0.25\%$	0.9%	
$V_{HYS}$	Hysteresis voltage <sup>(2)</sup>	TPS3702xXx	0.3%	0.55%	0.8%	
$V_{(POR)}$	Power-on reset voltage <sup>(1)</sup>	$V_{OL(max)} = 0.25V$ , $I_{OUT} = 15\mu A$			0.8	V
$I_{DD}$	Supply current	$V_{DD} = 2V$		6.0	10	$\mu A$
		$V_{DD} \geq 5V$		7.0	12	
$I_{SENSE}$	Input current, SENSE pin	$V_{SENSE} = 5V$		1	1.5	$\mu A$
$I_{SET}$	Internal pull-up current, SET pin	$V_{DD} = 18V$ , SET pin = GND		600		nA
$V_{OL}$	Low-level output voltage	$V_{DD} = 1.3V$ , $I_{OUT} = 0.4mA$			250	mV
		$V_{DD} = 2V$ , $I_{OUT} = 3mA$			250	
		$V_{DD} = 5V$ , $I_{OUT} = 5mA$			250	
$V_{IL(set)}$	Low-level SET pin input voltage				250	mV
$V_{IH(set)}$	High-level SET pin input voltage		750			mV
$I_{D(leak)}$	Open-drain output leakage current	$V_{PU} = V_{DD}$			300	nA
$I_{LKG(od)}$		$V_{DD} = 2V$ , $V_{PU} = 18V$			300	
UVLO	Undervoltage lockout <sup>(3)</sup>	$V_{DD}$ falling	1.3		1.7	V

- (1) The outputs are undetermined below  $V_{(POR)}$ .  
(2) Hysteresis is 0.55% of the nominal trip point.  
(3) When  $V_{DD}$  falls below UVLO, UV is driven low and OV goes to high impedance.

## 5.6 Timing Requirements

At  $V_{DD} = 2V$ , 2.5% input overdrive<sup>(4)</sup> with  $R_{PU} = 10k\Omega$ ,  $V_{OH} = 0.9 \times V_{DD}$ , and  $V_{OL} = 400mV$ , unless otherwise noted.  $R_{PU}$  refers to the pull-up resistor at the UV and OV pins.

		MIN	NOM	MAX	UNIT
$t_{pd(HL)}$	High-to-low propagation delay <sup>(1)</sup>		19		$\mu s$
$t_{pd(LH)}$	Low-to-high propagation delay <sup>(1)</sup>		35		$\mu s$
$t_R$	Output rise time <sup>(2)</sup>		2.2		$\mu s$
$t_F$	Output fall time <sup>(2)</sup>		0.22		$\mu s$
$t_{SD}$	Startup delay <sup>(3)</sup>		300		$\mu s$

- (1) High-to-low and low-to-high refers to the transition at the SENSE pin
- (2) Output transitions from 10% to 90% for rise times and 90% to 10% for fall times.
- (3) During the power-on sequence,  $V_{DD}$  must be at or above 2V for at least  $t_{SD}$  before the output is in the correct state.
- (4) Overdrive =  $| (V_{(VDD)} / V_{IT} - 1) \times 100\% |$ .

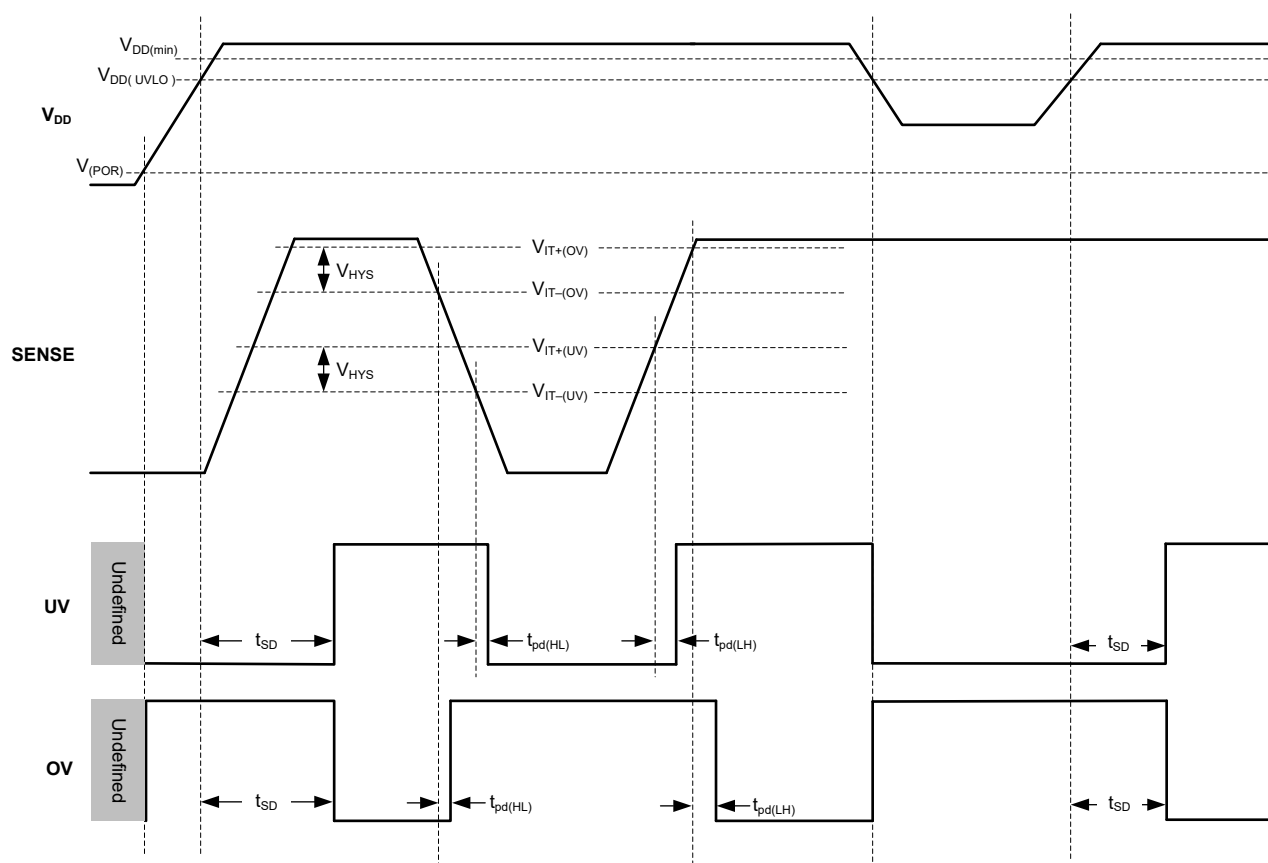

**Figure 5-1. Timing Diagram**

### 5.7 Typical Characteristics

At  $T_J = 25^\circ\text{C}$ ,  $V_{DD} = 3\text{V}$ , and  $R_{PU} = 10\text{k}\Omega$ , unless otherwise noted.

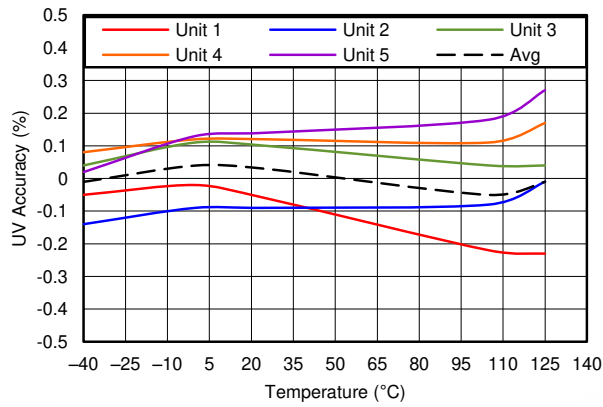

Performance is across  $V_{DD}$  with SET high or low  
**Figure 5-2. Undervoltage Accuracy vs Temperature**

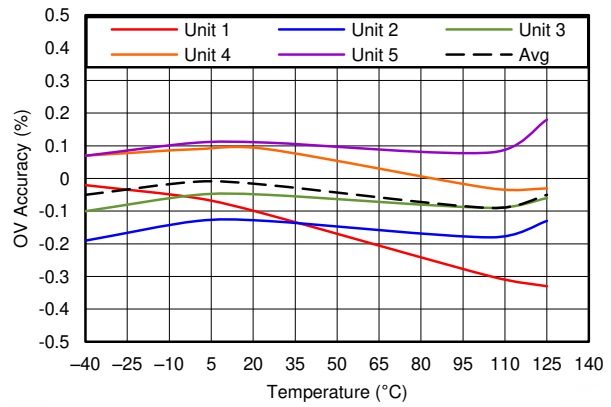

Performance is across  $V_{DD}$  with SET high or low  
**Figure 5-3. Overvoltage Accuracy vs Temperature**

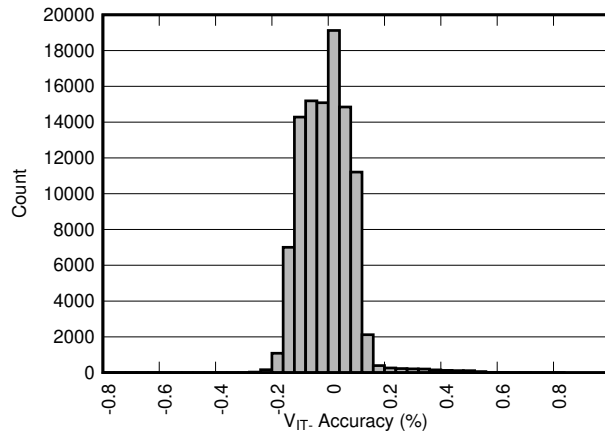

Performance is across  $V_{DD}$  with SET high or low  
**Figure 5-4. Undervoltage Accuracy Distribution**

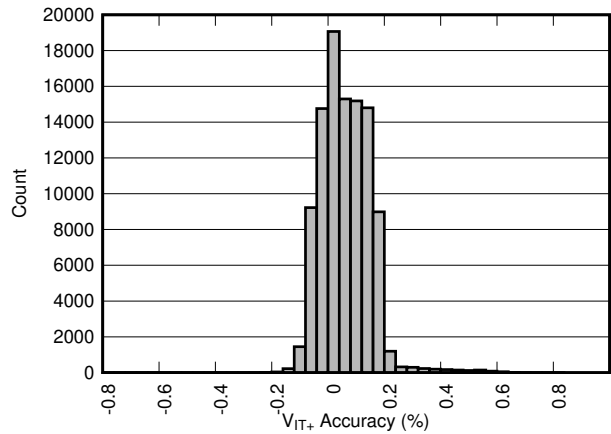

Performance is across  $V_{DD}$  with SET high or low  
**Figure 5-5. Overvoltage Accuracy Distribution**

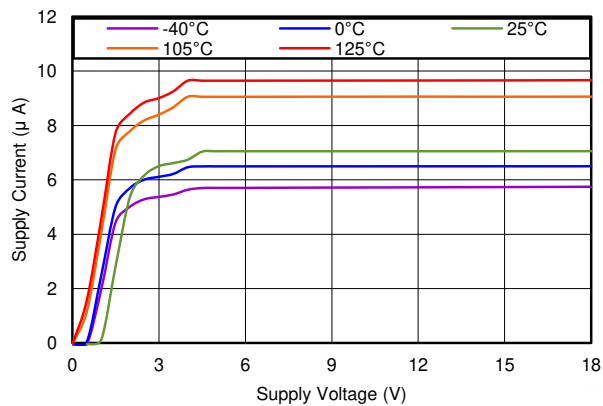

**Figure 5-6. Supply Current vs Supply Voltage**

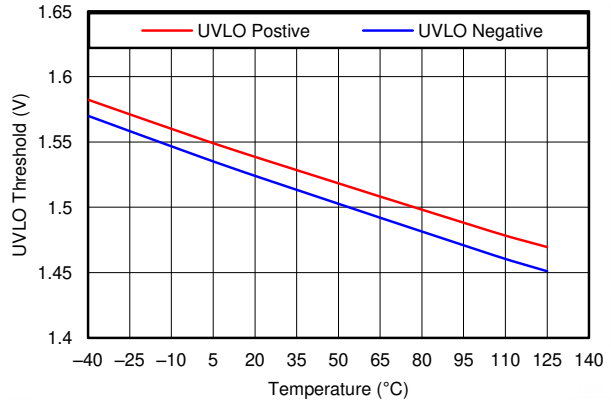

**Figure 5-7. Undervoltage Lockout Threshold vs Temperature**

### 5.7 Typical Characteristics (continued)

At  $T_J = 25^\circ\text{C}$ ,  $V_{DD} = 3\text{V}$ , and  $R_{PU} = 10\text{k}\Omega$ , unless otherwise noted.

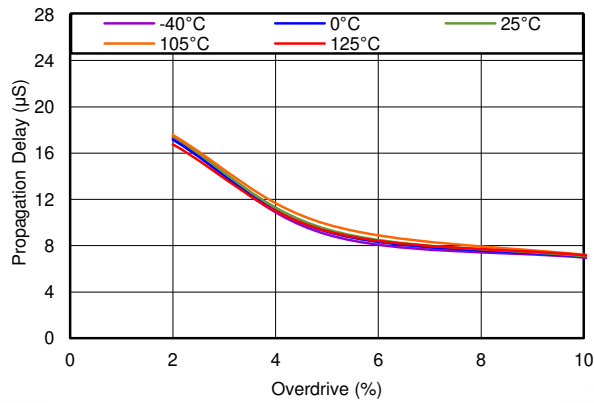

SENSE transitions from high to low  
**Figure 5-8. Undervoltage Propagation Delay vs Overdrive**

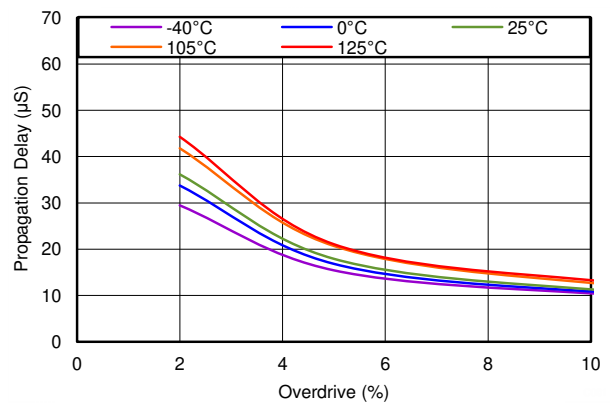

SENSE transitions from low to high  
**Figure 5-9. Overvoltage Propagation Delay vs Overdrive**

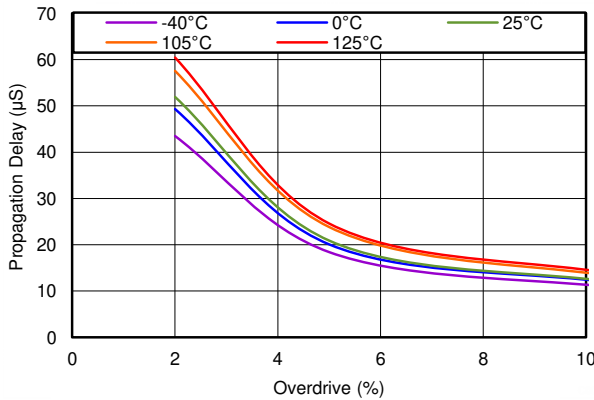

SENSE transitions from low to high  
**Figure 5-10. Undervoltage Propagation Delay vs Overdrive**

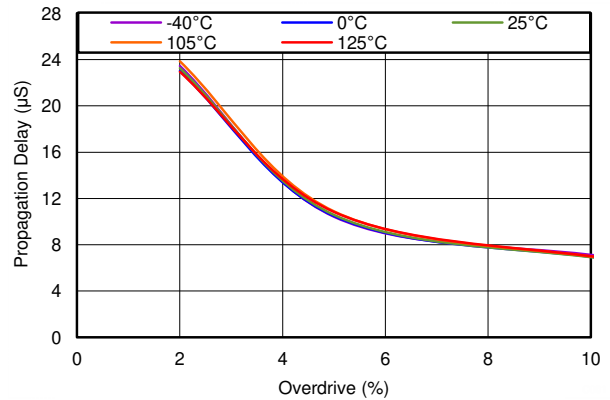

SENSE transitions from high to low  
**Figure 5-11. Overvoltage Propagation Delay vs Overdrive**

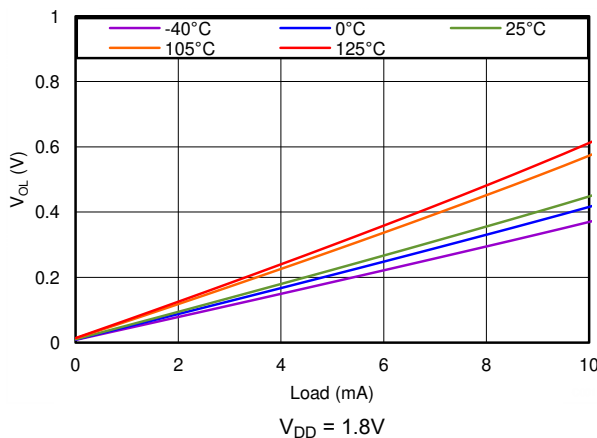

$V_{DD} = 1.8\text{V}$   
**Figure 5-12. Low-Level Output Voltage vs Output Current**

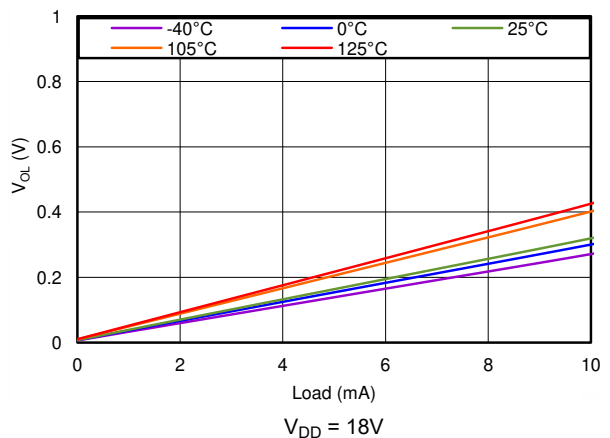

$V_{DD} = 18\text{V}$   
**Figure 5-13. Low-Level Output Voltage vs Output Current**

### 5.7 Typical Characteristics (continued)

At  $T_J = 25^\circ\text{C}$ ,  $V_{DD} = 3\text{V}$ , and  $R_{PU} = 10\text{k}\Omega$ , unless otherwise noted.

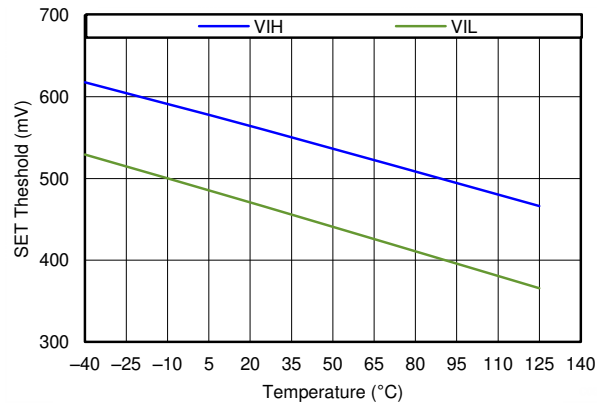

**Figure 5-14. SET Threshold vs Temperature**

## 6 Detailed Description

### 6.1 Overview

The TPS3702 family of devices combines two comparators and a precision reference for overvoltage and undervoltage detection. The TPS3702 features a wide supply voltage range (2V to 18V) and highly accurate window threshold voltages (0.9% over temperature). The TPS3702 is designed for systems that require an active low signal if the voltage from the monitored power supply exits the accuracy band. The outputs can be pulled up to 18V and can sink up to 10mA.

Unlike many other window voltage detectors, the TPS3702 includes the resistors used to set the overvoltage and undervoltage thresholds internal to the device. These internal resistors allow for lower component counts and greatly simplifies the design because no additional margins are needed to account for the accuracy of external resistors.

The TPS3702 is designed to assert active low output signals when the monitored voltage is outside the window band. The relationship between the monitored voltage and the states of the outputs is shown in [Table 6-1](#).

**Table 6-1. Truth Table**

CONDITION	OUTPUT	STATUS
$SENSE < V_{IT-(UV)}$	UV low	UV is asserted
$SENSE > V_{IT-(UV)} + V_{HYS}$	UV high	UV is high impedance
$SENSE > V_{IT+(OV)}$	OV low	OV is asserted
$SENSE < V_{IT+(OV)} - V_{HYS}$	OV high	OV is high impedance

### 6.2 Functional Block Diagram

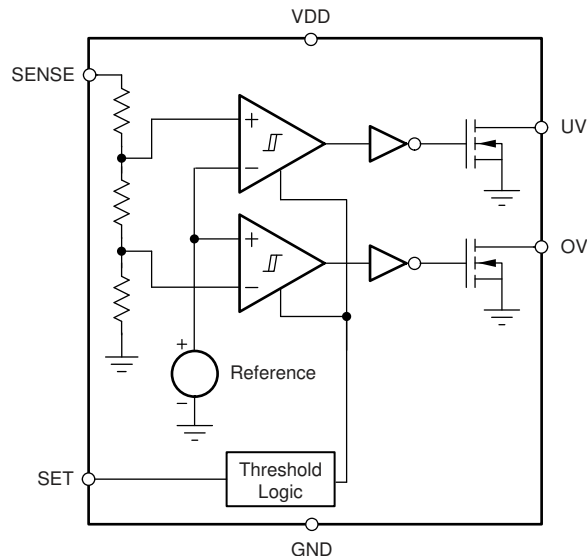

## 6.3 Feature Description

### 6.3.1 Input (SENSE)

The TPS3702 combines two comparators with a precision reference voltage and a trimmed resistor divider. Only a single external input is monitored by the two comparators because the resistor divider is internal to the device. This configuration optimizes device accuracy because all resistor tolerances are accounted for in the accuracy and performance specifications. Both comparators also include built-in hysteresis that provides some noise immunity and maintains stable operation.

The SENSE input can vary from ground to 6.5V (7.0V, absolute maximum), regardless of the device supply voltage used. Although not required in most cases, for noisy applications good analog design practice is to place a 1nF to 10nF bypass capacitor at the SENSE input to reduce sensitivity to transient voltages on the monitored signal.

For the undervoltage detector, the undervoltage output is driven to logic low when the SENSE voltage drops below the undervoltage falling threshold,  $V_{IT-(UV)}$ . When the voltage exceeds the undervoltage rising threshold,  $V_{IT+(UV)}$  (which is  $V_{IT-(UV)} + V_{HYS}$ ), the undervoltage output goes to a high-impedance state; see [Figure 5-1](#).

For the overvoltage detector, the overvoltage output is driven to logic low when the voltage at SENSE exceeds the overvoltage rising threshold,  $V_{IT+(OV)}$ . When the voltage drops below the overvoltage falling threshold,  $V_{IT-(OV)}$  (which is  $V_{IT+(OV)} - V_{HYS}$ ), the overvoltage output goes to a high-impedance state; see [Figure 5-1](#). Together, these two comparators form a window voltage detector function as described in the [Section 7.1.1](#) section. Also see the [Section 10.1.2](#) section.

### 6.3.2 Outputs (UV, OV)

In a typical TPS3702 application, the outputs are connected to a reset or enable input of a processor [such as a digital signal processor (DSP), application-specific integrated circuit (ASIC), or other processor type] or the outputs are connected to the enable input of a voltage regulator [such as a dc-dc converter or low-dropout regulator (LDO)].

The TPS3702 provides two open-drain outputs (UV and OV) and uses pull-up resistors to hold these lines high when the output goes to a high-impedance state. Connect the pull-up resistors to the proper voltage rails to enable the outputs to be connected to other devices at the correct interface voltage levels. The TPS3702 outputs can be pulled up to 18V, independent of the device supply voltage. To make sure of proper voltage levels, give some consideration when choosing the pull-up resistor values. The pull-up resistor value is determined by  $V_{OL}$ , output capacitive loading, and output leakage current ( $I_{D(leak)}$ ). These values are specified in the [Section 5.5](#) table. Use wired-OR logic to merge the undervoltage and overvoltage signals into one logic signal that goes low if either outputs are asserted because of a fault condition.

[Table 6-1](#) describes how the outputs are either asserted low or high impedance. See [Figure 5-1](#) for a timing diagram that describes the relationship between the threshold voltages and the respective output.

### 6.3.3 User-Configurable Accuracy Band (SET)

The TPS3702 has a remarkable feature allowing each device to be set for one of two accuracy bands, [Table 10-1](#) describes the available accuracy bands with nominal thresholds ranging from  $\pm 2\%$  to  $\pm 10\%$  of the monitored rail nominal voltage. Forcing the voltage on the SET pin above the high-level SET pin input voltage,  $V_{IH(SET)}$ , sets the thresholds for the tighter window whereas forcing the voltage on the SET pin below the low-level SET pin input voltage,  $V_{IL(SET)}$ , sets the thresholds for the wider window.

Using the TPS3702Cxxx as an example, when  $V_{SET} \geq V_{IH(SET)}$  the nominal thresholds are set to  $\pm 4\%$  (see [Figure 6-1](#)). Thus, when the positive-going and negative-going threshold accuracy is accounted for, the device outputs an active low signal for voltage excursions outside a  $\pm 4.9\%$  band (worst case), which is calculated by taking the nominal threshold percentage for that given part number and adding that value to the threshold accuracy found in the [Section 5](#) section. Similarly, when  $V_{SET} \leq V_{IL(SET)}$ , the nominal thresholds are set to  $\pm 9\%$  and the device outputs an active low signal for voltage excursions outside the  $\pm 9.9\%$  band (worst case).

The ability for the user to change the accuracy band allows a system to programmatically change the accuracy band during certain conditions. One example is during system start up when the monitored voltage can be

slightly outside the typical accuracy specifications but a reset signal is not desired. In this case,  $V_{SET}$  can be set below  $V_{IL(SET)}$  to detect voltage excursions outside the 10% band and, after the system is fully started up,  $V_{SET}$  can be pulled higher than  $V_{IH(SET)}$ , thus tightening the band to  $\pm 5\%$ .

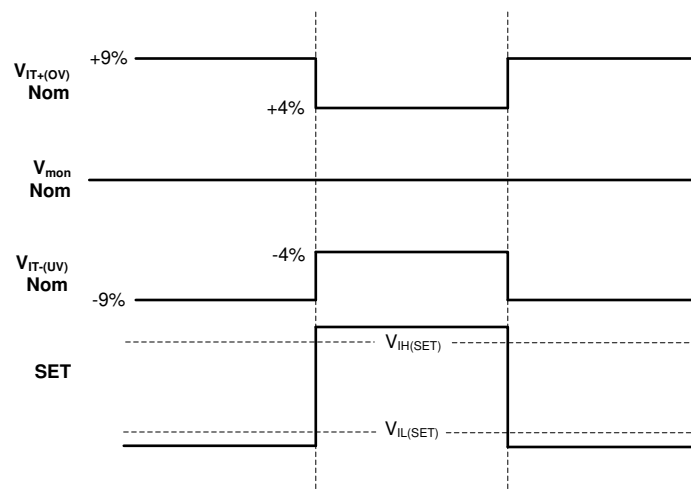

**Figure 6-1. TPS3702Cxxx User-Configurable Accuracy Bands**

Another benefit of allowing the user to change the accuracy band is the reduction in qualification costs. Users who have multiple rail monitoring needs (such as some rails that must be within  $\pm 5\%$  of the nominal voltage and other rails that must be within  $\pm 10\%$  of the same nominal voltage) benefit by only having to spend the time and money qualifying one device instead of two.

## 6.4 Device Functional Modes

### 6.4.1 Normal Operation ( $V_{DD} > UVLO$ )

When the voltage on VDD is greater than UVLO for approximately  $300\mu\text{s}$  ( $t_{SD}$ ), the undervoltage and overvoltage signals correspond to the voltage on the SENSE pin; see [Table 6-1](#).

### 6.4.2 Undervoltage Lockout ( $V_{POR} < V_{DD} < UVLO$ )

When the voltage on VDD is less than the device UVLO voltage but greater than the power-on reset voltage ( $V_{POR}$ ), the undervoltage output is asserted and the overvoltage output is high impedance, regardless of the voltage on SENSE.

### 6.4.3 Power-On Reset ( $V_{DD} < V_{POR}$ )

When the voltage on VDD is lower than the required voltage to internally pull the asserted output to GND ( $V_{POR}$ ), both outputs are undefined and are not to be relied upon for proper device function.

## 7 Application and Implementation

### Note

Information in the following applications sections is not part of the TI component specification, and TI does not warrant its accuracy or completeness. TI's customers are responsible for determining suitability of components for their purposes, as well as validating and testing their design implementation to confirm system functionality.

### 7.1 Application Information

The TPS3702 is a precision window voltage detector that can be used in several different configurations. The supply voltage ( $V_{DD}$ ), the monitored voltage, and the output pull-up voltage can be independent voltages or connected in many configurations. [Figure 7-1](#) shows how the outputs operate with respect to the voltage on the SENSE pin.

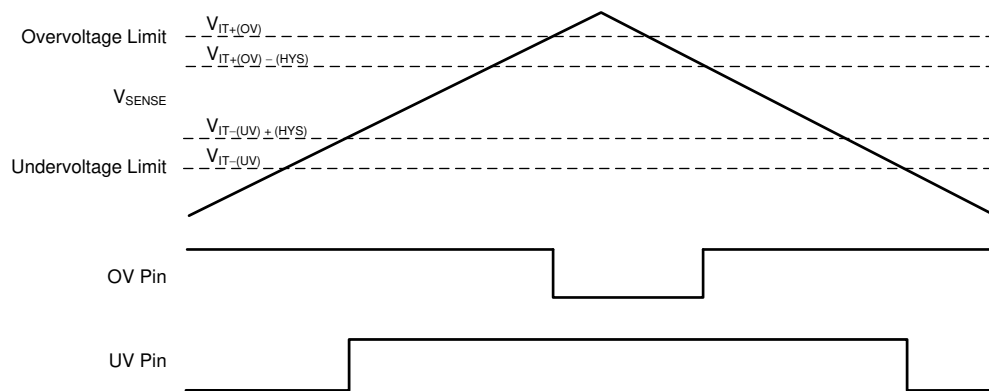
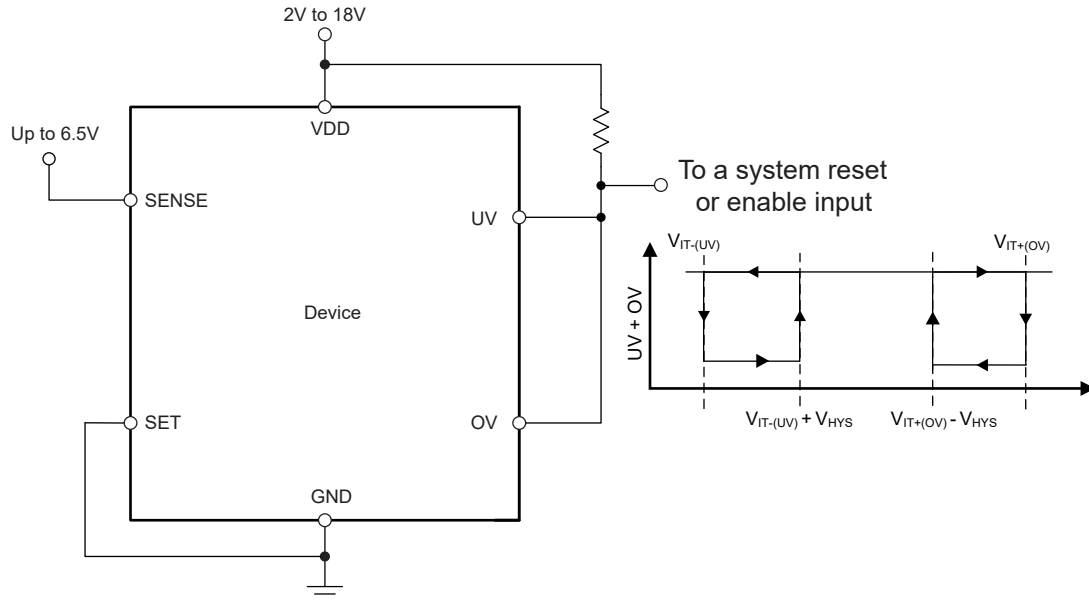

**Figure 7-1. Window Voltage Detector Operation**

The following sections show the connection configurations and the voltage limitations for each configuration.

### 7.1.1 Window Voltage Detector Considerations

The inverting and non-inverting configurations of the comparators form a window voltage detector circuit by using the internal resistor divider. The internal resistor divider allows for set voltage thresholds that already account for the tolerances of the resistors in the resistor divider. The UV and OV pins signal undervoltage and overvoltage conditions, respectively, on the SENSE pin, as shown in Figure 7-2.

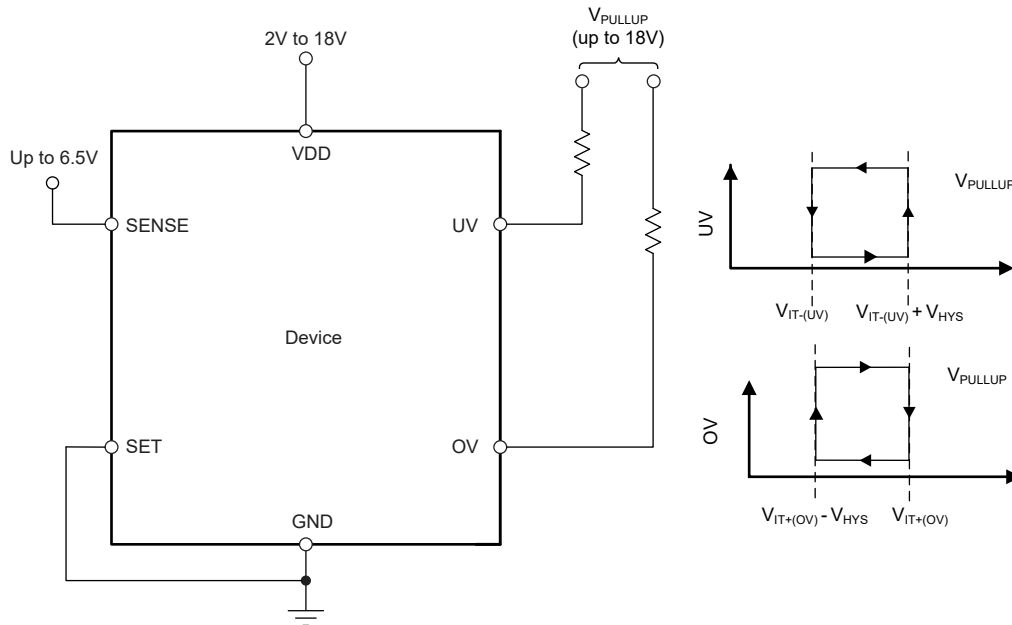

**Figure 7-2. Window Voltage Detector Schematic**

The TPS3702 flags the overvoltage or undervoltage conditions with the most accuracy to make sure of proper system operation. The highest accuracy threshold voltages are  $V_{IT-(UV)}$  and  $V_{IT+(OV)}$ , and correspond with the falling SENSE undervoltage flag and the rising SENSE overvoltage flag, respectively. These thresholds represent the accuracy when the monitored voltage changes from being within the desired window (when both the undervoltage and overvoltage outputs are high) to when the monitored voltage goes outside the desired window, indicating a fault condition. If the monitored voltage is outside of the valid window ( $V_{SENSE}$  is less than the undervoltage limit,  $V_{IT-(UV)}$ , or greater than overvoltage limit,  $V_{IT+(OV)}$ ), then the SENSE threshold voltages to enter into the valid window are  $V_{IT+(UV)} = V_{IT-(UV)} + V_{HYS}$  or  $V_{IT-(OV)} = V_{IT+(OV)} - V_{HYS}$ .

### 7.1.2 Input and Output Configurations

Figure 7-3 to Figure 7-5 illustrate examples of the various input and output configurations.



**Figure 7-3. Interfacing to Voltages Other Than  $V_{DD}$**

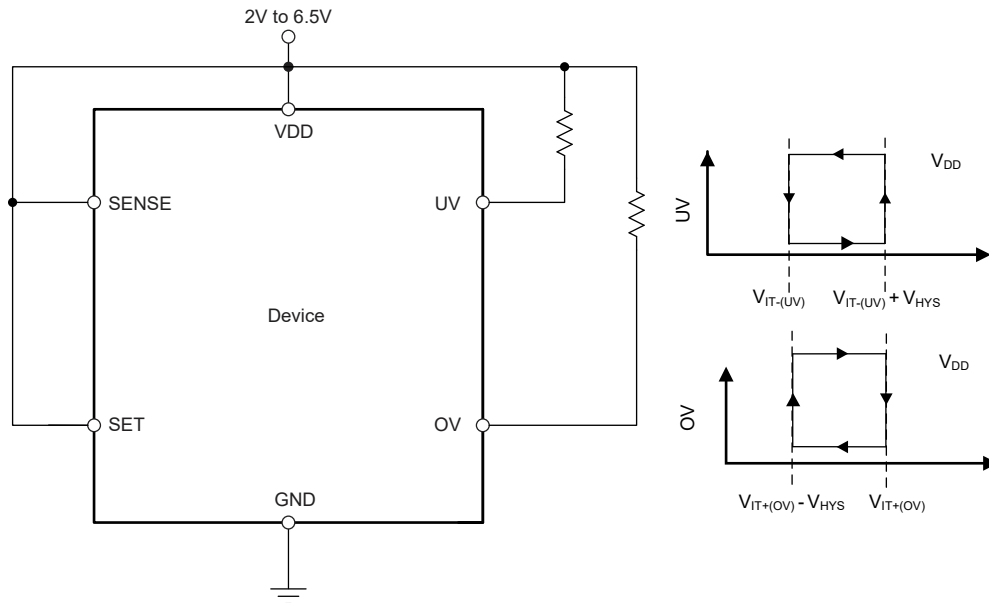

**Figure 7-4. Monitoring the Same Voltage as  $V_{DD}$  with Wired-OR Logic**

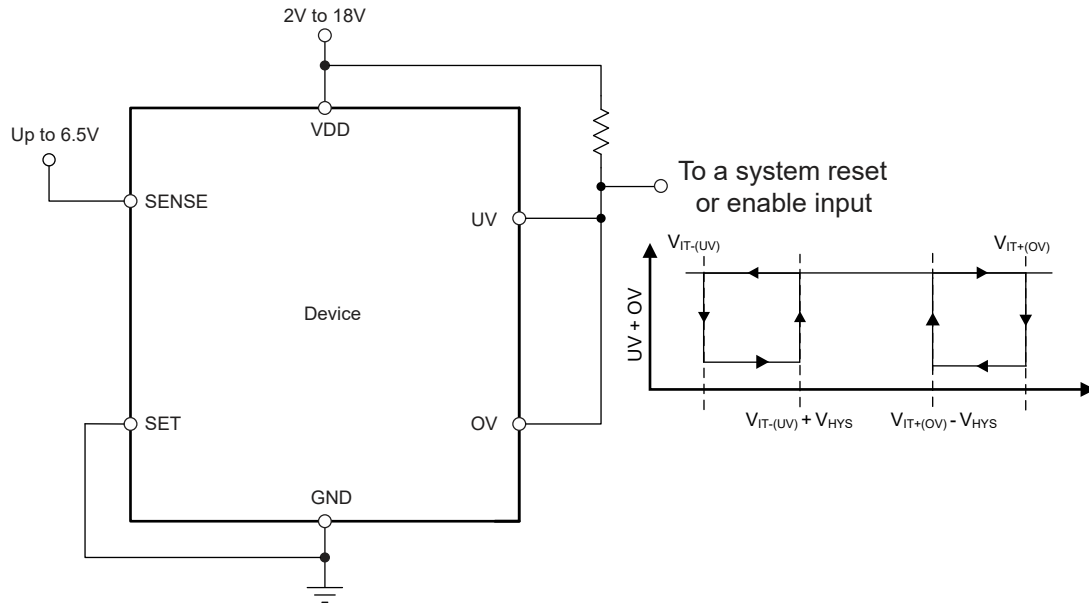

**Figure 7-5. Monitoring a Voltage Other Than  $V_{DD}$  with Wired-OR Logic**

Note that the SENSE input can also monitor voltages that are higher than  $V_{SENSE(max)}$  or that may not be designed for rail voltages with the use of an external resistor divider network. If a resistor divider is used to reduce the voltage on the SENSE pin, make sure that the  $I_{SENSE}$  current is accounted for so the accuracy is not unexpectedly affected. As a general approximation, the current flowing through the resistor divider to ground must be greater than 100 times the current going into the SENSE pin. See application report *Optimizing Resistor Dividers at a Comparator Input* (SLVA450) for a more in-depth discussion on setting an external resistor divider.

### 7.1.3 Immunity to SENSE Pin Voltage Transients

The TPS3702 is immune to short voltage transient spikes on the input pins. Sensitivity to transients depends on both transient duration and overdrive (amplitude) of the transient.

Overdrive is defined by how much the  $V_{SENSE}$  exceeds the specified threshold, and is important to know because the smaller the overdrive, the slower the response of the outputs (UV and OV). Threshold overdrive is calculated as a percent of the threshold in question, as shown in Equation 1:

$$\text{Overdrive} = | (V_{SENSE} / V_{IT} - 1) \times 100\% | \quad (1)$$

where:

- $V_{IT}$  is either  $V_{IT-}$  or  $V_{IT+}$  for UV or OV.

Figure 5-8 to Figure 5-11 illustrate the  $V_{SENSE}$  minimum detectable pulse versus overdrive, and can be used to visualize the relationship that overdrive has on propagation delay.

## 7.2 Typical Application

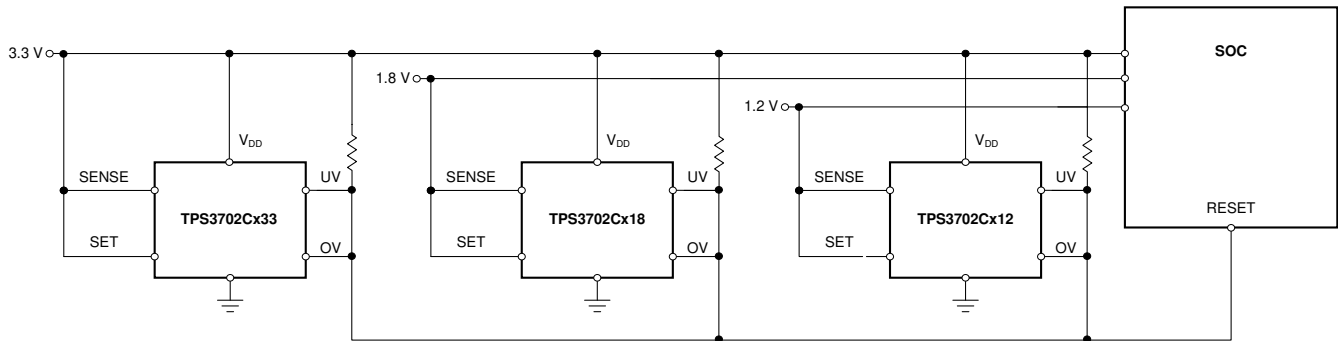

Figure 7-6.  $\pm 5\%$  Window Voltage Detector for SOC Power Rails

### 7.2.1 Design Requirements

Table 7-1. Design Parameters

PARAMETER	DESIGN REQUIREMENT	DESIGN RESULT
Monitored rails	3.3V nominal, with alerts if outside of $\pm 5\%$ of 3.3V (including device accuracy)	Worst case $V_{IT+(OV)} = 3.463V$ (4.94%), Worst case $V_{IT-(UV)} = 3.139V$ (4.86%)
	1.8V nominal, with alerts if outside of $\pm 5\%$ of 1.8V (including device accuracy)	Worst case $V_{IT+(OV)} = 1.889V$ (4.94%), Worst case $V_{IT-(UV)} = 1.712V$ (4.86%)
	1.2V nominal, with alerts if outside of $\pm 5\%$ of 1.2V (including device accuracy)	Worst case $V_{IT+(OV)} = 1.259V$ (4.94%), Worst case $V_{IT-(UV)} = 1.142V$ (4.86%)
Output logic voltage	3.3V CMOS	3.3V CMOS
Maximum device current consumption	50 $\mu A$	40.5 $\mu A$ (maximum), 24 $\mu A$ (typical)

### 7.2.2 Detailed Design Procedure

Determine which version of the TPS3702 best suits the application nominal rail and window tolerances. See [Table 10-1](#) for selecting the appropriate device number for the application needs. If the nominal rail voltage to be monitored is not listed as an option, a resistor divider can be used to reduce the voltage to a nominal voltage that is available. The current  $I_{SENSE}$  causes an error in the voltage detected at the SENSE pin because the SENSE current only flows through the resistor at the top of the resistor divider. The larger the current through the resistor divider to ground, the smaller this error can be. To optimize this resistor divider, refer to application report *Optimizing Resistor Dividers at a Comparator Input* ([SLVA450](#)) for more information.

When the outputs switch to the high-Z state, the rise time of the UV or OV node depends on the pull-up resistance and the capacitance on that node. Choose pull-up resistors that satisfy both the downstream timing requirements and the sink current required to have a  $V_{OL}$  low enough for the application; 10k $\Omega$  to 1M $\Omega$  resistors are a good choice for low-capacitive loads.

### 7.2.3 Application Curves

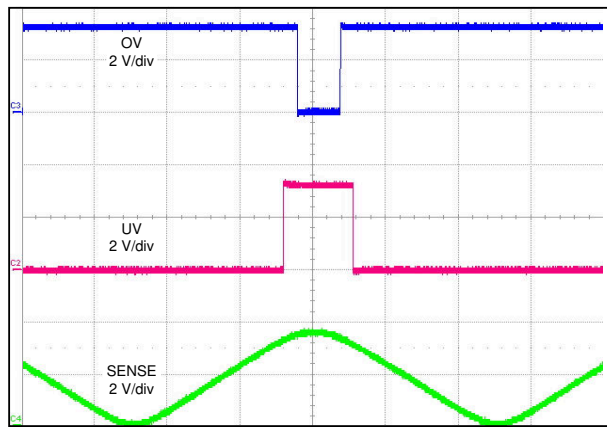

Time (1 ms/div)

$V_{SENSE}$  goes from 0V to 3.47V ( $V_{IT+(OV)}$ ),  $V_{DD} = 3.3V$ ,  $V_{PULL-UP} = 3.3V$

**Figure 7-7. TPS3702CX33 Window Voltage Detector Function**

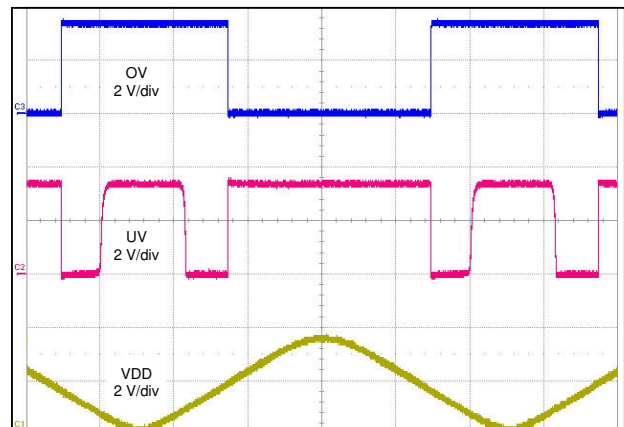

Time (1 ms/div)

$V_{DD}$  goes from 0V to 3.3V,  $V_{SENSE} = 3.47V$  (above  $V_{IT+(OV)}$ )

**Figure 7-8. TPS3702CX33 Startup with  $V_{PULL-UP} = 3V$**

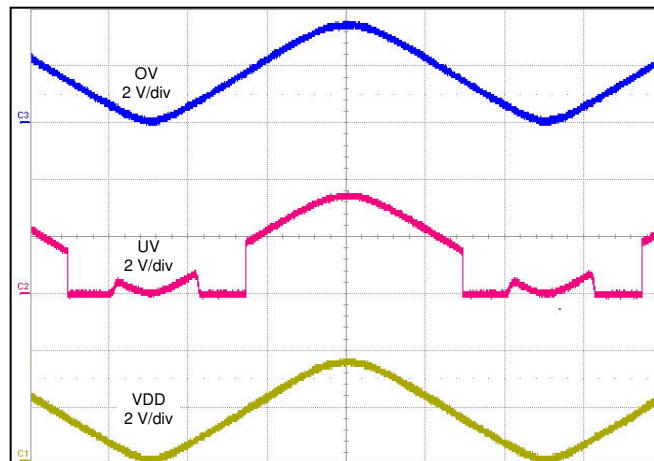

Time (1 ms/div)

$V_{DD}$  goes from 0V to 3.3V,  $V_{SENSE} = 3.3V$

**Figure 7-9. TPS3702CX33 Startup with  $V_{PULL-UP} = V_{DD}$**

## 8 Power Supply Recommendations

The TPS3702 is designed to operate from an input voltage supply range between 2V and 18V. An input supply capacitor is not required for this device; however, if the input supply is noisy good analog practice is to place a 0.1 $\mu$ F capacitor between the VDD pin and the GND pin. This device has a 20V absolute maximum rating on the VDD pin. If the voltage supply providing power to VDD is susceptible to any large voltage transient that can exceed 20V, additional precautions must be taken.

## 9 Layout

### 9.1 Layout Guidelines

- Place the VDD decoupling capacitor close to the device.
- Avoid using long traces for the VDD supply node. The VDD capacitor ( $C_{VDD}$ ), along with parasitic inductance from the supply to the capacitor, can form an LC tank and create ringing with peak voltages above the maximum VDD voltage.

### 9.2 Layout Example

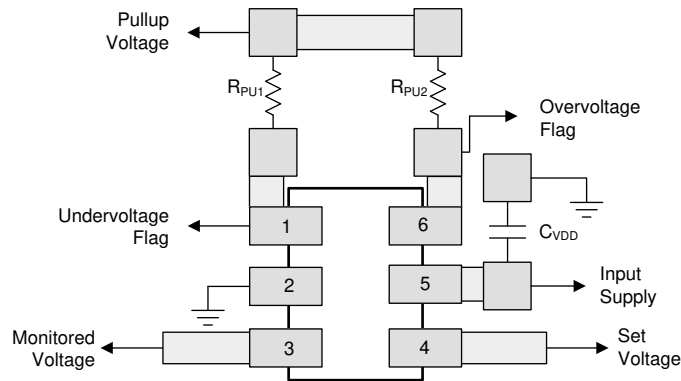

**Figure 9-1. Recommended Layout**

## 10 Device and Documentation Support

### 10.1 Device Support

#### 10.1.1 Development Support

##### 10.1.1.1 Evaluation Module

An evaluation module (EVM) is available to assist in the initial circuit performance evaluation using the TPS3702. The [TPS3702CX33EVM-683 evaluation module](#) (and [related user guide](#)) can be requested at the Texas Instruments website through the product folders or purchased directly from the [TI eStore](#).

#### 10.1.2 Device Nomenclature

[Table 10-1](#) shows how to decode the function of the device based on the part number, with TPS3702CX33 used as an example.

**Table 10-1. Device Naming Convention**

DESCRIPTION	NOMENCLATURE	VALUE
TPS3702 (high-accuracy window voltage detector family)	—	—
C (nominal thresholds as a percent of the nominal monitored voltage)	A	SET pin high = ±2%, SET pin low = ±6%
	B	SET pin high = ±3%, SET pin low = ±7%
	C	SET pin high = ±4%, SET pin low = ±9%
	D	SET pin high = ±5%, SET pin low = ±10%
X (hysteresis option)	X	0.55%
	Y	1.0%
33 (nominal monitored voltage option)	10	1.0V
	12	1.2V
	18	1.8V
	33	3.3V
	50	5.0V

[Table 10-2](#) shows the released versions of the TPS3702, including the nominal undervoltage and overvoltage thresholds. Contact the factory for details and availability of other options shown in [Table 10-1](#); minimum order quantities apply.

**Table 10-2. Released Device Thresholds**

PRODUCT	NOMINAL SUPPLY (V)	HYSTERESIS (%)	UV THRESHOLD (V) $SET \leq V_{IL(SET)}$	UV THRESHOLD (V) $SET \geq V_{IH(SET)}$	OV THRESHOLD (V) $SET \leq V_{IL(SET)}$	OV THRESHOLD (V) $SET \geq V_{IH(SET)}$
TPS3702CX10	1.0	0.5	0.91	0.96	1.09	1.04
TPS3702CX12	1.2	0.5	1.09	1.15	1.31	1.25
TPS3702AX18	1.8	0.5	1.69	1.76	1.91	1.84
TPS3702CX18	1.8	0.5	1.64	1.73	1.96	1.87
TPS3702AX33	3.3	0.5	3.10	3.23	3.50	3.37
TPS3702CX33	3.3	0.5	3.00	3.17	3.60	3.43
TPS3702CX50	5.0	0.5	4.55	4.80	5.45	5.20

## 10.2 Documentation Support

### 10.2.1 Related Documentation

*Optimizing Resistor Dividers at a Comparator Input*, [SLVA450](#)

*TPS3702CX33EVM-683 Evaluation Module*, [SBVU026](#)

## 10.3 Support Resources

[TI E2E™ support forums](#) are an engineer's go-to source for fast, verified answers and design help — straight from the experts. Search existing answers or ask your own question to get the quick design help you need.

Linked content is provided "AS IS" by the respective contributors. They do not constitute TI specifications and do not necessarily reflect TI's views; see TI's [Terms of Use](#).

## 10.4 Trademarks

TI E2E™ is a trademark of Texas Instruments.

All trademarks are the property of their respective owners.

## 10.5 Electrostatic Discharge Caution



This integrated circuit can be damaged by ESD. Texas Instruments recommends that all integrated circuits be handled with appropriate precautions. Failure to observe proper handling and installation procedures can cause damage.

ESD damage can range from subtle performance degradation to complete device failure. Precision integrated circuits may be more susceptible to damage because very small parametric changes could cause the device not to meet its published specifications.

## 10.6 Glossary

[TI Glossary](#) This glossary lists and explains terms, acronyms, and definitions.

## 11 Revision History

Changes from Revision * (January 2015) to Revision A (February 2024)	Page
• Changed device naming to "voltage detector" throughout data sheet .....	1
• Updated the numbering format for tables, figures, and cross-references throughout the document.....	1
• Changed first two sentences of Description section.....	1
• Updated timing diagram.....	6
• Changed device naming to voltage detector.....	10
• Updated images for Input and Output Configurations.....	15

---

## 12 Mechanical, Packaging, and Orderable Information

The following pages include mechanical, packaging, and orderable information. This information is the most current data available for the designated devices. This data is subject to change without notice and revision of this document. For browser-based versions of this data sheet, refer to the left-hand navigation.

**PACKAGING INFORMATION**

Orderable Device	Status (1)	Package Type	Package Drawing	Pins	Package Qty	Eco Plan (2)	Lead finish/ Ball material (6)	MSL Peak Temp (3)	Op Temp (°C)	Device Marking (4/5)	Samples
TPS3702AX18DDCR	ACTIVE	SOT-23-THIN	DDC	6	3000	RoHS & Green	NIPDAU	Level-2-260C-1 YEAR	-40 to 125	ZAUO	<a href="#">Samples</a>
TPS3702AX18DDCT	ACTIVE	SOT-23-THIN	DDC	6	250	RoHS & Green	NIPDAU	Level-2-260C-1 YEAR	-40 to 125	ZAUO	<a href="#">Samples</a>
TPS3702AX33DDCR	ACTIVE	SOT-23-THIN	DDC	6	3000	RoHS & Green	NIPDAU	Level-2-260C-1 YEAR	-40 to 125	ZAPO	<a href="#">Samples</a>
TPS3702AX33DDCT	ACTIVE	SOT-23-THIN	DDC	6	250	RoHS & Green	NIPDAU	Level-2-260C-1 YEAR	-40 to 125	ZAPO	<a href="#">Samples</a>
TPS3702CX10DDCR	ACTIVE	SOT-23-THIN	DDC	6	3000	RoHS & Green	NIPDAU	Level-2-260C-1 YEAR	-40 to 125	ZARO	<a href="#">Samples</a>
TPS3702CX10DDCT	ACTIVE	SOT-23-THIN	DDC	6	250	RoHS & Green	NIPDAU	Level-2-260C-1 YEAR	-40 to 125	ZARO	<a href="#">Samples</a>
TPS3702CX12DDCR	ACTIVE	SOT-23-THIN	DDC	6	3000	RoHS & Green	NIPDAU	Level-2-260C-1 YEAR	-40 to 125	ZAVO	<a href="#">Samples</a>
TPS3702CX12DDCT	ACTIVE	SOT-23-THIN	DDC	6	250	RoHS & Green	NIPDAU	Level-2-260C-1 YEAR	-40 to 125	ZAVO	<a href="#">Samples</a>
TPS3702CX18DDCR	ACTIVE	SOT-23-THIN	DDC	6	3000	RoHS & Green	NIPDAU	Level-2-260C-1 YEAR	-40 to 125	ZAWO	<a href="#">Samples</a>
TPS3702CX18DDCT	ACTIVE	SOT-23-THIN	DDC	6	250	RoHS & Green	NIPDAU	Level-2-260C-1 YEAR	-40 to 125	ZAWO	<a href="#">Samples</a>
TPS3702CX33DDCR	ACTIVE	SOT-23-THIN	DDC	6	3000	RoHS & Green	NIPDAU	Level-2-260C-1 YEAR	-40 to 125	ZAQO	<a href="#">Samples</a>
TPS3702CX33DDCT	ACTIVE	SOT-23-THIN	DDC	6	250	RoHS & Green	NIPDAU	Level-2-260C-1 YEAR	-40 to 125	ZAQO	<a href="#">Samples</a>
TPS3702CX50DDCR	ACTIVE	SOT-23-THIN	DDC	6	3000	RoHS & Green	NIPDAU	Level-2-260C-1 YEAR	-40 to 125	ZASO	<a href="#">Samples</a>
TPS3702CX50DDCT	ACTIVE	SOT-23-THIN	DDC	6	250	RoHS & Green	NIPDAU	Level-2-260C-1 YEAR	-40 to 125	ZASO	<a href="#">Samples</a>

(1) The marketing status values are defined as follows:

**ACTIVE:** Product device recommended for new designs.

**LIFEBUY:** TI has announced that the device will be discontinued, and a lifetime-buy period is in effect.

**NRND:** Not recommended for new designs. Device is in production to support existing customers, but TI does not recommend using this part in a new design.

**PREVIEW:** Device has been announced but is not in production. Samples may or may not be available.

**OBSELETE:** TI has discontinued the production of the device.

(2) **RoHS:** TI defines "RoHS" to mean semiconductor products that are compliant with the current EU RoHS requirements for all 10 RoHS substances, including the requirement that RoHS substance do not exceed 0.1% by weight in homogeneous materials. Where designed to be soldered at high temperatures, "RoHS" products are suitable for use in specified lead-free processes. TI may reference these types of products as "Pb-Free".

**RoHS Exempt:** TI defines "RoHS Exempt" to mean products that contain lead but are compliant with EU RoHS pursuant to a specific EU RoHS exemption.

**Green:** TI defines "Green" to mean the content of Chlorine (Cl) and Bromine (Br) based flame retardants meet JS709B low halogen requirements of <=1000ppm threshold. Antimony trioxide based flame retardants must also meet the <=1000ppm threshold requirement.

(3) MSL, Peak Temp. - The Moisture Sensitivity Level rating according to the JEDEC industry standard classifications, and peak solder temperature.

(4) There may be additional marking, which relates to the logo, the lot trace code information, or the environmental category on the device.

(5) Multiple Device Markings will be inside parentheses. Only one Device Marking contained in parentheses and separated by a "~" will appear on a device. If a line is indented then it is a continuation of the previous line and the two combined represent the entire Device Marking for that device.

(6) Lead finish/Ball material - Orderable Devices may have multiple material finish options. Finish options are separated by a vertical ruled line. Lead finish/Ball material values may wrap to two lines if the finish value exceeds the maximum column width.

**Important Information and Disclaimer:** The information provided on this page represents TI's knowledge and belief as of the date that it is provided. TI bases its knowledge and belief on information provided by third parties, and makes no representation or warranty as to the accuracy of such information. Efforts are underway to better integrate information from third parties. TI has taken and continues to take reasonable steps to provide representative and accurate information but may not have conducted destructive testing or chemical analysis on incoming materials and chemicals. TI and TI suppliers consider certain information to be proprietary, and thus CAS numbers and other limited information may not be available for release.

In no event shall TI's liability arising out of such information exceed the total purchase price of the TI part(s) at issue in this document sold by TI to Customer on an annual basis.

**OTHER QUALIFIED VERSIONS OF TPS3702 :**

- Automotive: [TPS3702-Q1](#)

NOTE: Qualified Version Definitions:

- Automotive - Q100 devices qualified for high-reliability automotive applications targeting zero defects

## TAPE AND REEL INFORMATION



### QUADRANT ASSIGNMENTS FOR PIN 1 ORIENTATION IN TAPE



\*All dimensions are nominal

Device	Package Type	Package Drawing	Pins	SPQ	Reel Diameter (mm)	Reel Width W1 (mm)	A0 (mm)	B0 (mm)	K0 (mm)	P1 (mm)	W (mm)	Pin1 Quadrant
TPS3702AX18DDCR	SOT-23-THIN	DDC	6	3000	179.0	8.4	3.2	3.2	1.4	4.0	8.0	Q3
TPS3702AX18DDCT	SOT-23-THIN	DDC	6	250	179.0	8.4	3.2	3.2	1.4	4.0	8.0	Q3
TPS3702AX33DDCR	SOT-23-THIN	DDC	6	3000	179.0	8.4	3.2	3.2	1.4	4.0	8.0	Q3
TPS3702AX33DDCT	SOT-23-THIN	DDC	6	250	180.0	8.4	3.2	3.2	1.4	4.0	8.0	Q3
TPS3702CX10DDCR	SOT-23-THIN	DDC	6	3000	179.0	8.4	3.2	3.2	1.4	4.0	8.0	Q3
TPS3702CX10DDCT	SOT-23-THIN	DDC	6	250	179.0	8.4	3.2	3.2	1.4	4.0	8.0	Q3
TPS3702CX12DDCR	SOT-23-THIN	DDC	6	3000	179.0	8.4	3.2	3.2	1.4	4.0	8.0	Q3
TPS3702CX12DDCT	SOT-23-THIN	DDC	6	250	179.0	8.4	3.2	3.2	1.4	4.0	8.0	Q3
TPS3702CX18DDCR	SOT-23-THIN	DDC	6	3000	179.0	8.4	3.2	3.2	1.4	4.0	8.0	Q3
TPS3702CX18DDCT	SOT-23-THIN	DDC	6	250	179.0	8.4	3.2	3.2	1.4	4.0	8.0	Q3
TPS3702CX33DDCR	SOT-	DDC	6	3000	180.0	8.4	3.2	3.2	1.4	4.0	8.0	Q3

Device	Package Type	Package Drawing	Pins	SPQ	Reel Diameter (mm)	Reel Width W1 (mm)	A0 (mm)	B0 (mm)	K0 (mm)	P1 (mm)	W (mm)	Pin1 Quadrant
	23-THIN											
TPS3702CX33DDCT	SOT-23-THIN	DDC	6	250	180.0	8.4	3.2	3.2	1.4	4.0	8.0	Q3
TPS3702CX50DDCR	SOT-23-THIN	DDC	6	3000	179.0	8.4	3.2	3.2	1.4	4.0	8.0	Q3
TPS3702CX50DDCT	SOT-23-THIN	DDC	6	250	180.0	8.4	3.2	3.2	1.4	4.0	8.0	Q3

## TAPE AND REEL BOX DIMENSIONS

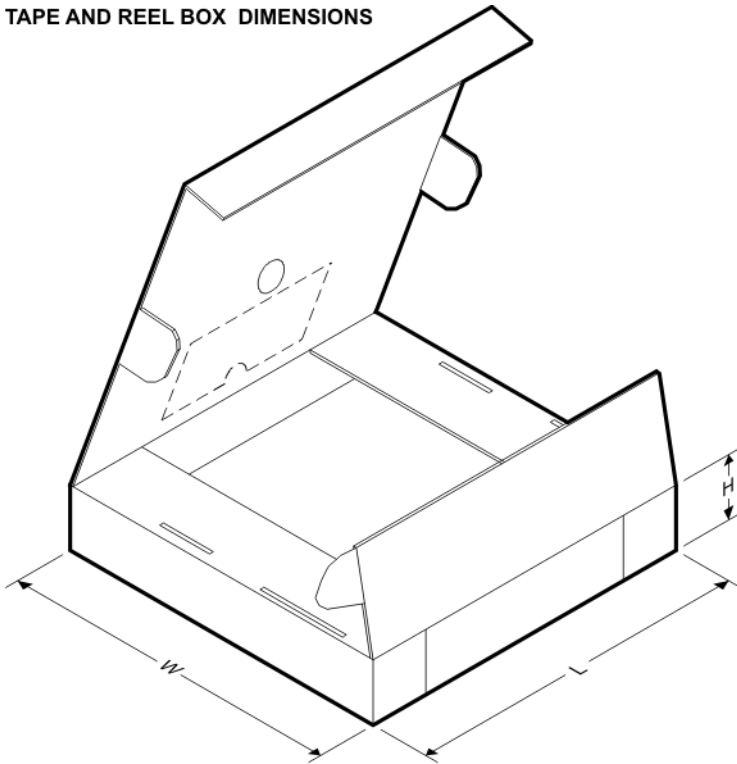

\*All dimensions are nominal

Device	Package Type	Package Drawing	Pins	SPQ	Length (mm)	Width (mm)	Height (mm)
TPS3702AX18DDCR	SOT-23-THIN	DDC	6	3000	213.0	191.0	35.0
TPS3702AX18DDCT	SOT-23-THIN	DDC	6	250	213.0	191.0	35.0
TPS3702AX33DDCR	SOT-23-THIN	DDC	6	3000	213.0	191.0	35.0
TPS3702AX33DDCT	SOT-23-THIN	DDC	6	250	213.0	191.0	35.0
TPS3702CX10DDCR	SOT-23-THIN	DDC	6	3000	213.0	191.0	35.0
TPS3702CX10DDCT	SOT-23-THIN	DDC	6	250	213.0	191.0	35.0
TPS3702CX12DDCR	SOT-23-THIN	DDC	6	3000	213.0	191.0	35.0
TPS3702CX12DDCT	SOT-23-THIN	DDC	6	250	213.0	191.0	35.0
TPS3702CX18DDCR	SOT-23-THIN	DDC	6	3000	213.0	191.0	35.0
TPS3702CX18DDCT	SOT-23-THIN	DDC	6	250	213.0	191.0	35.0
TPS3702CX33DDCR	SOT-23-THIN	DDC	6	3000	213.0	191.0	35.0

---

Device	Package Type	Package Drawing	Pins	SPQ	Length (mm)	Width (mm)	Height (mm)
TPS3702CX33DDCT	SOT-23-THIN	DDC	6	250	213.0	191.0	35.0
TPS3702CX50DDCR	SOT-23-THIN	DDC	6	3000	213.0	191.0	35.0
TPS3702CX50DDCT	SOT-23-THIN	DDC	6	250	213.0	191.0	35.0

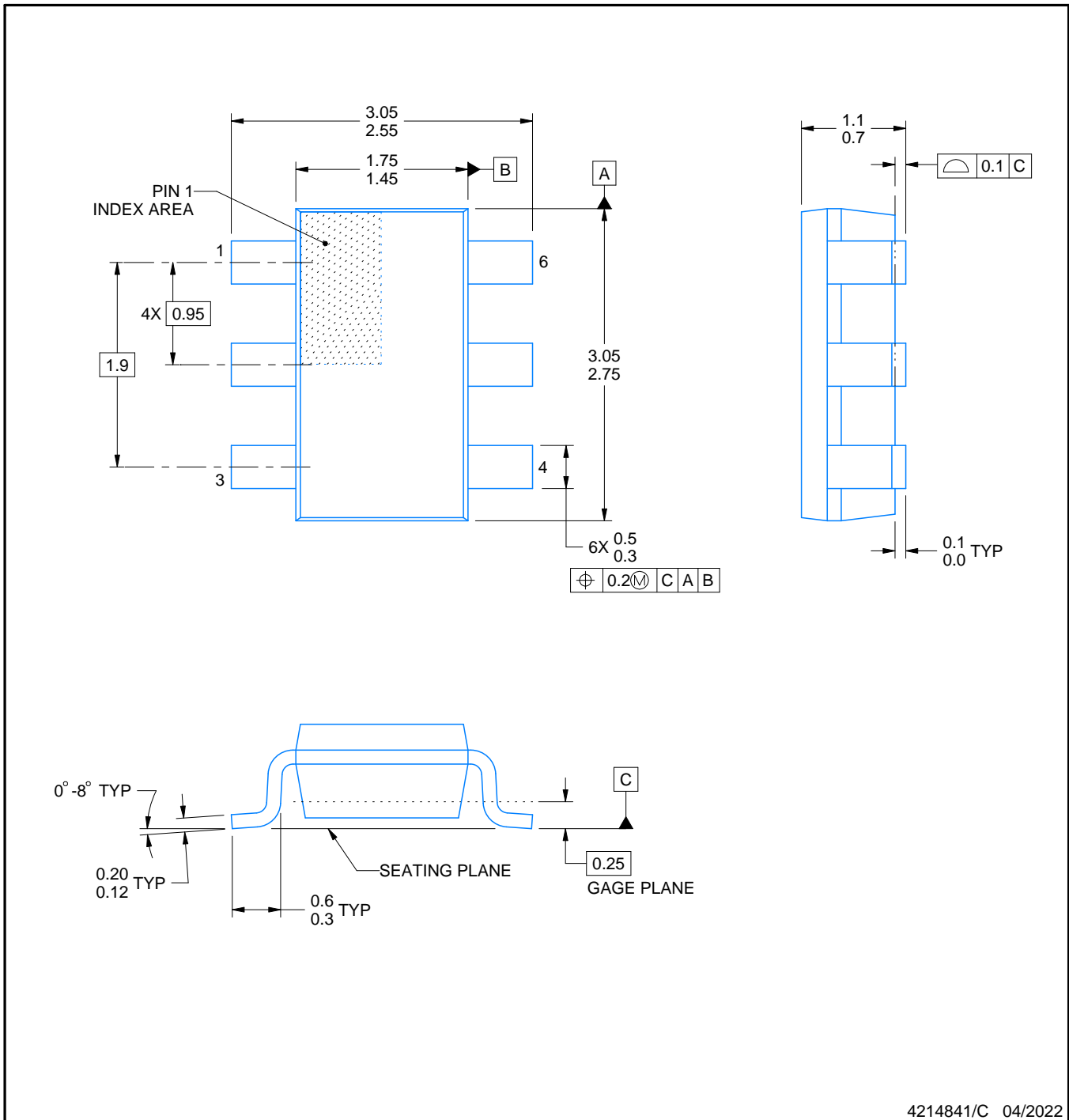

NOTES:

- All linear dimensions are in millimeters. Any dimensions in parenthesis are for reference only. Dimensioning and tolerancing per ASME Y14.5M.
- This drawing is subject to change without notice.
- Reference JEDEC MO-193.

# EXAMPLE BOARD LAYOUT

DDC0006A

SOT-23 - 1.1 max height

SMALL OUTLINE TRANSISTOR

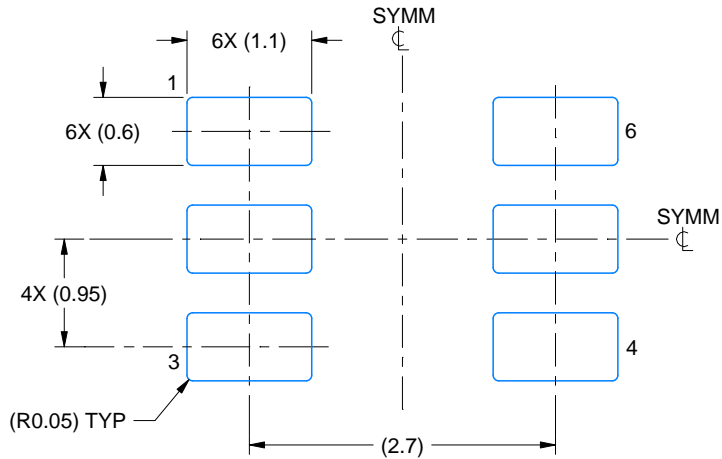

LAND PATTERN EXAMPLE  
EXPLODED METAL SHOWN  
SCALE:15X

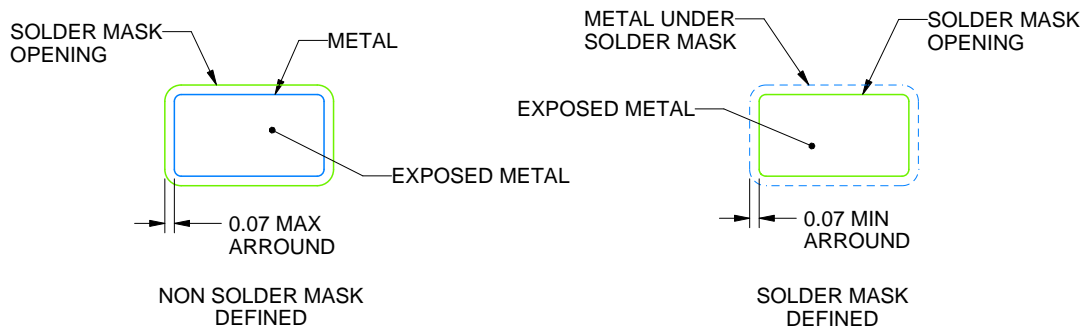

SOLDERMASK DETAILS

4214841/C 04/2022

NOTES: (continued)

- 4. Publication IPC-7351 may have alternate designs.
- 5. Solder mask tolerances between and around signal pads can vary based on board fabrication site.

# EXAMPLE STENCIL DESIGN

DDC0006A

SOT-23 - 1.1 max height

SMALL OUTLINE TRANSISTOR

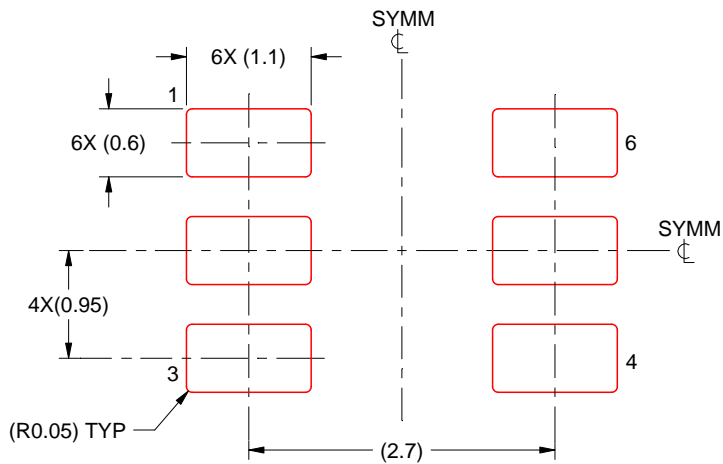

SOLDER PASTE EXAMPLE  
BASED ON 0.125 THICK STENCIL  
SCALE:15X

4214841/C 04/2022

NOTES: (continued)

6. Laser cutting apertures with trapezoidal walls and rounded corners may offer better paste release. IPC-7525 may have alternate design recommendations.
7. Board assembly site may have different recommendations for stencil design.

## IMPORTANT NOTICE AND DISCLAIMER

TI PROVIDES TECHNICAL AND RELIABILITY DATA (INCLUDING DATA SHEETS), DESIGN RESOURCES (INCLUDING REFERENCE DESIGNS), APPLICATION OR OTHER DESIGN ADVICE, WEB TOOLS, SAFETY INFORMATION, AND OTHER RESOURCES "AS IS" AND WITH ALL FAULTS, AND DISCLAIMS ALL WARRANTIES, EXPRESS AND IMPLIED, INCLUDING WITHOUT LIMITATION ANY IMPLIED WARRANTIES OF MERCHANTABILITY, FITNESS FOR A PARTICULAR PURPOSE OR NON-INFRINGEMENT OF THIRD PARTY INTELLECTUAL PROPERTY RIGHTS.

These resources are intended for skilled developers designing with TI products. You are solely responsible for (1) selecting the appropriate TI products for your application, (2) designing, validating and testing your application, and (3) ensuring your application meets applicable standards, and any other safety, security, regulatory or other requirements.

These resources are subject to change without notice. TI grants you permission to use these resources only for development of an application that uses the TI products described in the resource. Other reproduction and display of these resources is prohibited. No license is granted to any other TI intellectual property right or to any third party intellectual property right. TI disclaims responsibility for, and you will fully indemnify TI and its representatives against, any claims, damages, costs, losses, and liabilities arising out of your use of these resources.

TI's products are provided subject to [TI's Terms of Sale](#) or other applicable terms available either on [ti.com](https://www.ti.com) or provided in conjunction with such TI products. TI's provision of these resources does not expand or otherwise alter TI's applicable warranties or warranty disclaimers for TI products.

TI objects to and rejects any additional or different terms you may have proposed.

Mailing Address: Texas Instruments, Post Office Box 655303, Dallas, Texas 75265  
Copyright © 2024, Texas Instruments Incorporated

## Looking for pricing, stock, or lifecycle information?

Click below to explore more details on WIN SOURCE:

 [View TPS3702CX12DDCT on WIN SOURCE](#)

 [Texas Instruments](#) Information

## Optimize Your Supply Chain with WIN SOURCE Solutions

-  Global Sourcing Solution
-  Obsolete Management
-  Cost Control Management
-  Shortage Management
-  Alternative Solution
-  Excess Inventory Management