



**THE DATASHEET OF  
TPS2557QDRBTQ1**



# TPS255x-Q1 Precision Automotive Adjustable Current-Limited Power-Distribution Switches

## 1 Features

- AEC-Q100 Qualified
  - Device HBM ESD Classification Level H2
  - Device CDM ESD Classification Level C5
- **Functional Safety-Capable**
  - Documentation available to aid functional safety system design
- Meets USB current-limiting requirements
- Adjustable current limit, 500 mA – 5 A (typ.)
- $\pm 6.5\%$  current-limit accuracy at 4.5 A
- Fast short-circuit response – 3.5  $\mu\text{s}$  (typ.)
- 22-m $\Omega$  high-side MOSFET
- Operating range: 2.5 V to 6.5 V
- 2- $\mu\text{A}$  maximum standby supply current
- Built-in soft-start
- 15-kV and 8-kV system-level ESD capable
- Safety-related certifications:
  - UL Recognized for UL 2367
  - CB Certification for IEC 60950
  - CB Certification for IEC 62368

## 2 Application

Automotive USB Charging Ports

## 3 Description

The TPS2556-Q1 and TPS2557-Q1 power-distribution switches are specialized for automotive applications which require precision current limiting or capacity to handle heavy capacitive loads and short circuits. These devices offer a programmable current-limit threshold between 500 mA and 5 A (typical) via an external resistor. Control of the power-switch rise and fall times minimizes current surges during turnon or turnoff.

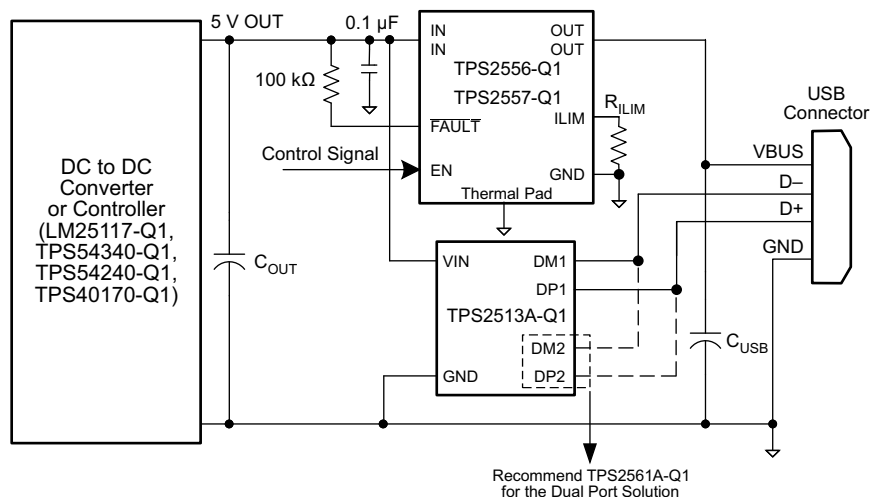
TPS2556-Q1 and TPS2557-Q1 devices limit the output current to a safe level by switching into a constant-current mode when the output load exceeds the current-limit threshold. The  $\overline{\text{FAULT}}$  logic output asserts low during overcurrent and overtemperature conditions.

Use with the TPS2511-Q1 or TPS2513A-Q1 for a low-loss, automotive-qualified, USB charging-port solution capable of charging all of today's popular phones and tablets.

### Device Information

ORDER NUMBER	PACKAGE <sup>(1)</sup>	BODY SIZE
TPS2556QDRB	S-PVSON (8)	3 mm × 3 mm
TPS2557QDRB	S-PVSON (8)	3 mm × 3 mm

(1) For all available packages, see the orderable addendum at the end of the data sheet.



Typical Application as Power Switch of Single-Port Automotive USB Charge Port



## Table of Contents

<b>1 Features</b> .....	1	8.2 Functional Block Diagram.....	10
<b>2 Application</b> .....	1	8.3 Feature Description.....	10
<b>3 Description</b> .....	1	8.4 Device Functional Modes.....	11
<b>4 Revision History</b> .....	2	<b>9 Applications and Implementation</b> .....	13
<b>5 Device Comparison Table</b> .....	3	9.1 Application Information.....	13
<b>6 Terminal Configuration and Functions</b> .....	3	9.2 Typical Application, Design for Current Limit.....	13
Terminal Functions.....	3	<b>10 Power Supply Recommendations</b> .....	18
<b>7 Specifications</b> .....	3	<b>11 Layout</b> .....	19
7.1 Absolute Maximum Ratings.....	3	11.1 Layout Guidelines.....	19
7.2 Handling Ratings.....	4	11.2 Layout Example.....	19
7.3 Recommended Operating Conditions.....	4	<b>12 Device and Documentation Support</b> .....	20
7.4 Thermal Information.....	4	12.1 Related Links.....	20
7.5 Electrical Characteristics.....	5	12.2 Trademarks.....	20
7.6 Switching Characteristics.....	5	12.3 Electrostatic Discharge Caution.....	20
7.7 Typical Characteristics.....	6	12.4 Glossary.....	20
<b>Parameter Measurement Information</b> .....	8	<b>13 Mechanical, Packaging, and Orderable Information</b> .....	21
<b>8 Detailed Description</b> .....	8		
8.1 Overview.....	8		

## 4 Revision History

Changes from Revision A (March 2014) to Revision B (September 2020)	Page
• Added functional safety link and safety-related certifications bullet to the <i>Features</i> section .....	1
• Updated the numbering format for tables, figures and cross-references throughout the document.....	1

Changes from Revision * (March 2014) to Revision A (March 2014)	Page
• Changed part number in Description from TPS2511-Q to TPS2511-Q1.....	1
• Changed CURRENT LIMIT values in Electrical Characteristics table .....	5
• Changed <a href="#">Equation 1</a> .....	13
• Revised <a href="#">Figure 9-2</a> graph.....	13
• Changed <a href="#">Equation 2</a> .....	14
• Changed resistor value from 33.2 kΩ to 33.6 kΩ .....	14
• Changed <a href="#">Equation 3</a> .....	14
• Changed <a href="#">Equation 4</a> .....	15
• Changed current-limit threshold from 4 316 mA to 4 406 mA .....	15
• Changed values in <a href="#">Table 9-2</a> .....	15

## 5 Device Comparison Table

DEVICE	MAX. OPERATING CURRENT (A)	OUTPUTS	ENABLES	TYPICAL $r_{DS(on)}$ (m $\Omega$ )
TPS2556-Q1	5	1	Active-low	22
TPS2557-Q1	5	1	Active-high	22
TPS2561A-Q1	2.5	2	Active-high	44

## 6 Terminal Configuration and Functions

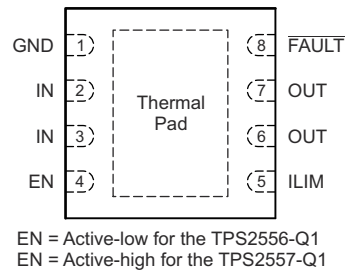


Figure 6-1. 8-Terminal S-PVSON With Thermal Pad DRB Package (Top View)

### Terminal Functions

NAME	TERMINAL		I/O	DESCRIPTION
	TPS2556-Q1	TPS2557-Q1		
EN	4	–	I	Enable input, logic low turns on power switch.
EN	–	4	I	Enable input, logic high turns on power switch.
GND	1	1	–	Ground connection; connect externally to PowerPAD.
IN	2, 3	2, 3	I	Input voltage; connect a 0.1 $\mu$ F or greater ceramic capacitor from IN to GND as close to the IC as possible.
FAULT	8	8	O	Active-low open-drain output, asserted during overcurrent or overtemperature conditions.
OUT	6, 7	6, 7	O	Power-switch output.
ILIM	5	5	O	External resistor used to set current-limit threshold; recommended $20 \text{ k}\Omega \leq R_{(ILIM)} \leq 187 \text{ k}\Omega$ .
Thermal pad	–	–	–	Internally connected to GND; used to heat-sink the part to the circuit board traces. Connect thermal pad to GND terminal externally.

## 7 Specifications

### 7.1 Absolute Maximum Ratings

over operating free-air temperature range unless otherwise noted<sup>(1) (2)</sup>

	MIN	MAX <sup>(2)</sup>	UNIT
Voltage range on IN, OUT, EN or $\overline{\text{EN}}$ , ILIM, FAULT	–0.3	7	V
Voltage range from IN to OUT	–7	7	V
I Continuous output current		Internally limited	
Continuous FAULT sink current		25	mA
ILIM source current		Internally limited	mA
$T_J$ Maximum junction temperature	–40	Internally limited	$^{\circ}\text{C}$

(1) Stresses beyond those listed under *Absolute Maximum Ratings* may cause permanent damage to the device. These are stress ratings only, which do not imply functional operation of the device at these or any other conditions beyond those indicated under *Recommended Operating Conditions*. Exposure to absolute-maximum-rated conditions for extended periods may affect device reliability.

(2) Voltages are referenced to GND unless otherwise noted.

## 7.2 Handling Ratings

PARAMETER		MIN	MAX	UNIT	
$T_{stg}$	Storage temperature range	-65	150	°C	
$V_{(ESD)}$ (1)	Human-body model (HBM) ESD stress voltage <sup>(2)</sup>	-2	2	kV	
	Charged-device model (CDM) ESD stress voltage <sup>(3)</sup>	-750	750	V	
	System level <sup>(4)</sup>	Contact discharge	-8	8	kV
		Air discharge	-15	15	

(1) Electrostatic discharge (ESD) to measure device sensitivity or immunity to damage caused by assembly-line electrostatic discharges into the device.

(2) The passing level per AEC-Q100 Classification H2.

(3) The passing level per AEC-Q100 Classification C5.

(4) Surges per EN61000-4-2, 1999 applied between USB connection for  $V_{(BUS)}$  and ground of the TPS2556EVM (HPA423, replacing TPS2556 with TPS2556-Q1) evaluation module (SLUU393). These were the test levels, not the failure threshold.

## 7.3 Recommended Operating Conditions

		MIN	MAX	UNIT	
$V_{(IN)}$	Input voltage, IN	2.5	6.5	V	
$V_{(EN)}$	Enable voltage	TPS2556-Q1	0	6.5	V
$V_{(EN)}$		TPS2557-Q1	0	6.5	
$V_{IH}$	High-level input voltage on EN or $\overline{EN}$	1.1		V	
$V_{IL}$	Low-level input voltage on EN or $\overline{EN}$		0.66		
$I_{(OUT)}$	Continuous output current, OUT	0	5	A	
	Continuous $\overline{FAULT}$ sink current	0	10	mA	
$T_J$	Operating junction temperature	-40	125	°C	
$R_{(ILIM)}$	Recommended limit-resistor range	20	187	kΩ	

## 7.4 Thermal Information

THERMAL METRIC <sup>(1)</sup>		TPS2556-Q1, TPS2557-Q1	UNIT
		DRB	
		8 TERMINALS	
$R_{\theta JA}$	Junction-to-ambient thermal resistance	41.5	°C/W
$R_{\theta JC(top)}$	Junction-to-case (top) thermal resistance	56	°C/W
$R_{\theta JB}$	Junction-to-board thermal resistance	16.4	°C/W
$\Psi_{JT}$	Junction-to-top characterization parameter	0.7	°C/W
$\Psi_{JB}$	Junction-to-board characterization parameter	16.5	°C/W
$R_{\theta JC(bot)}$	Junction-to-case (bottom) thermal resistance	3.5	°C/W

(1) For more information about traditional and new thermal metrics, see the *Semiconductor and IC Package Thermal Metrics* application report (SPRA953).

## 7.5 Electrical Characteristics

over recommended operating conditions,  $V_{EN} = 0\text{ V}$ , or  $V_{EN} = V_{IN}$  (unless otherwise noted)

PARAMETER		TEST CONDITIONS <sup>(1)</sup>	MIN	TYP	MAX	UNIT
<b>POWER SWITCH</b>						
$r_{DS(on)}$	Static drain-source on-state resistance	$T_J = 25^\circ\text{C}$		22	25	m $\Omega$
		$-40^\circ\text{C} \leq T_J \leq 125^\circ\text{C}$			35	
<b>ENABLE INPUT EN OR <math>\overline{\text{EN}}</math></b>						
	Enable terminal turnon or turnoff threshold		0.66		1.1	V
	Hysteresis			55 <sup>(2)</sup>		mV
$I_{(EN)}$	Input current	$V_{(EN)} = 0\text{ V}$ or $6.5\text{ V}$ , or $V_{(\overline{\text{EN}})} = 0\text{ V}$ or $6.5\text{ V}$	-0.5		0.5	$\mu\text{A}$
<b>CURRENT LIMIT</b>						
$I_{OS}$	Current-limit threshold (maximum dc output current $I_{(OUT)}$ delivered to load) and short-circuit current, OUT connected to GND	$R_{(ILIM)} = 24.9\text{ k}\Omega$	4180	4500	4745	mA
		$R_{(ILIM)} = 61.9\text{ k}\Omega$	1610	1805	1980	
		$R_{(ILIM)} = 100\text{ k}\Omega$	945	1110	1270	
<b>SUPPLY CURRENT</b>						
$I_{(IN\_off)}$	Supply current, low-level output	$V_{(IN)} = 6.5\text{ V}$ , no load on OUT, $V_{(\overline{\text{EN}})} = 6.5\text{ V}$ or $V_{(EN)} = 0\text{ V}$		0.1	2.5	$\mu\text{A}$
$I_{(IN\_on)}$	Supply current, high-level output	$V_{(IN)} = 6.5\text{ V}$ , no load on OUT	$R_{(ILIM)} = 24.9\text{ k}\Omega$	95	120	$\mu\text{A}$
			$R_{(ILIM)} = 100\text{ k}\Omega$	85	110	$\mu\text{A}$
$I_{(REV)}$	Reverse leakage current	$V_{(OUT)} = 6.5\text{ V}$ , $V_{IN} = 0\text{ V}$		0.01	1	$\mu\text{A}$
<b>UNDERVOLTAGE LOCKOUT</b>						
$V_{(UVLO)}$	Low-level input voltage, IN	$V_{(IN)}$ rising		2.35	2.45	V
	Hysteresis, IN			35 <sup>(2)</sup>		mV
<b>FAULT FLAG</b>						
$V_{OL}$	Output low voltage, $\overline{\text{FAULT}}$	$I_{(\overline{\text{FAULT}})} = 1\text{ mA}$			180	mV
	Off-state leakage	$V_{(\overline{\text{FAULT}})} = 6.5\text{ V}$			1	$\mu\text{A}$
	$\overline{\text{FAULT}}$ deglitch	$\overline{\text{FAULT}}$ assertion or de-assertion due to overcurrent condition	6	9	13	ms
<b>THERMAL SHUTDOWN</b>						
$T_{(OTSD2)}$	Thermal shutdown threshold		155			$^\circ\text{C}$
$T_{(OTSD)}$	Thermal shutdown threshold in current-limit		135			$^\circ\text{C}$
	Hysteresis			20 <sup>(2)</sup>		$^\circ\text{C}$

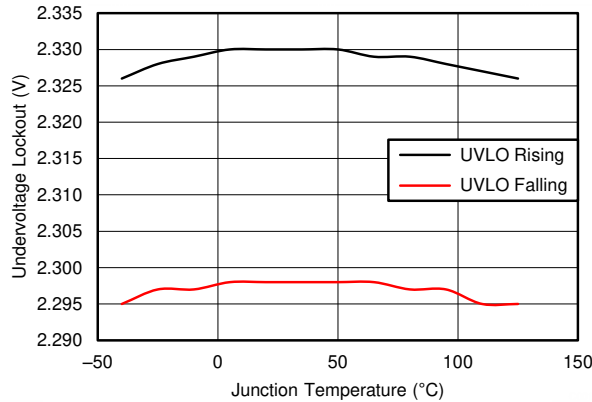
- (1) Pulse-testing techniques maintain junction temperature close to ambient temperature; thermal effects must be taken into account separately.
- (2) These parameters are provided for reference only, and do not constitute part of TI's published specifications for purposes of TI's product warranty.

## 7.6 Switching Characteristics

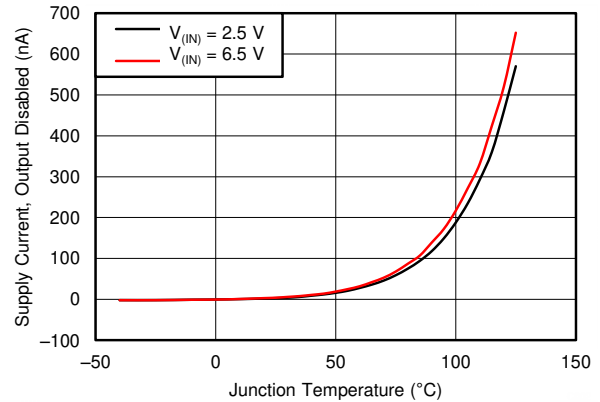
			MIN	TYP	MAX	UNIT
$t_r$	Rise time, output	$V_{IN} = 6.5\text{ V}$	2	3	4	ms
		$V_{IN} = 2.5\text{ V}$	1	2	3	
$t_f$	Fall time, output	$V_{IN} = 6.5\text{ V}$	0.6	0.8	1.0	
		$V_{IN} = 2.5\text{ V}$	0.4	0.6	0.8	
$t_{on}$	Turnon time	$C_L = 1\text{ }\mu\text{F}$ , $R_L = 100\text{ }\Omega$ , (see Figure 8-1)			9	ms
$t_{off}$	Turnoff time				6	ms
$t_{(IOS)}$	Response time to short circuit	$V_{(IN)} = 5\text{ V}$ (see Figure 8-2)		3.5 <sup>(1)</sup>		$\mu\text{s}$

- (1) These parameters are provided for reference only, and do not constitute part of TI's published specifications for purposes of TI's product warranty.

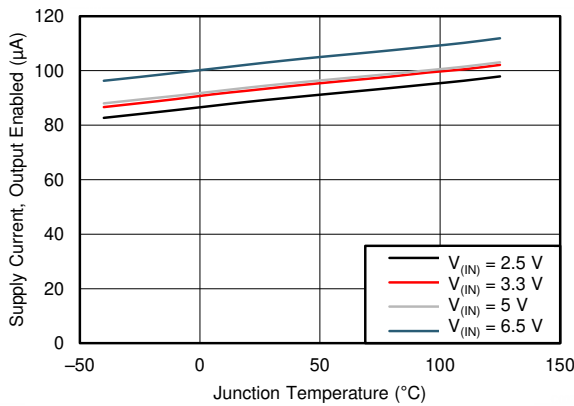
## 7.7 Typical Characteristics



**Figure 7-1. UVLO – Undervoltage Lockout – V**

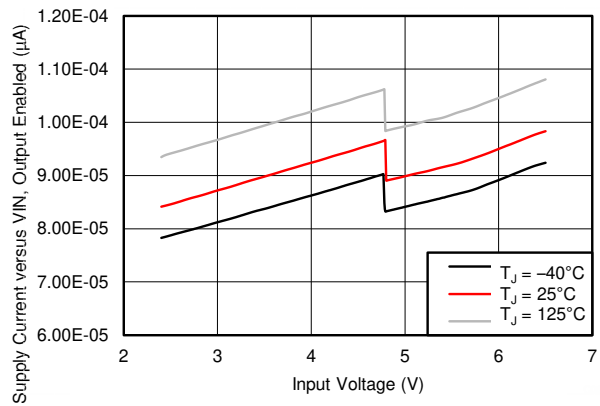


**Figure 7-2.  $I_{IN}$  – Supply Current, Output Disabled – nA**



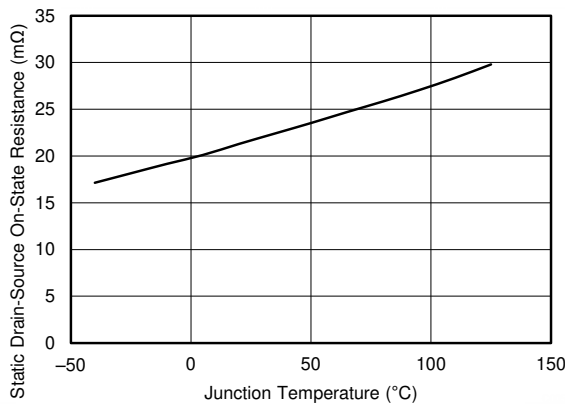
$R_{(ILIM)} = 24.9 \text{ k}\Omega$

**Figure 7-3.  $I_{IN}$  – Supply Current, Output Enabled –  $\mu\text{A}$**

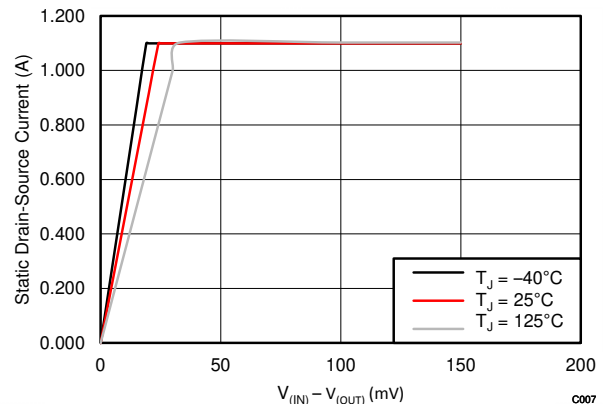


$R_{(ILIM)} = 24.9 \text{ k}\Omega$

**Figure 7-4.  $I_{IN}$  – Supply Current, Output Enabled –  $\mu\text{A}$**

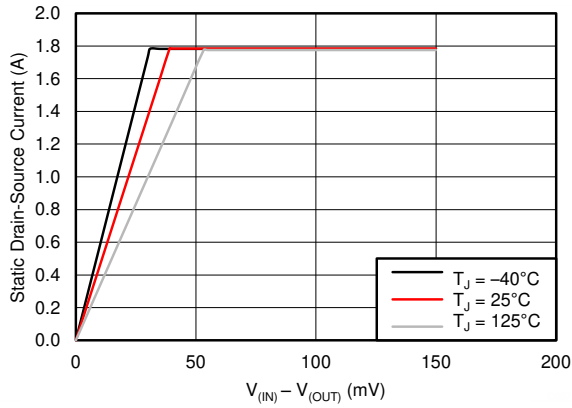


**Figure 7-5. MOSFET  $r_{DS(on)}$  Versus Junction Temperature**



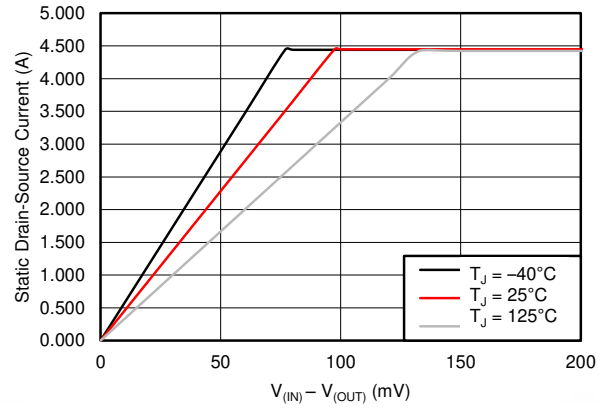
$R_{(ILIM)} = 100 \text{ k}\Omega$

**Figure 7-6. Switch Current Versus Drain-Source Voltage Across Switch**



$R_{(ILIM)} = 61.9 \text{ k}\Omega$

**Figure 7-7. Switch Current Versus Drain-Source Voltage Across Switch**



$R_{(ILIM)} = 24.9 \text{ k}\Omega$

**Figure 7-8. Switch Current Versus Drain-Source Voltage Across Switch**

## Parameter Measurement Information

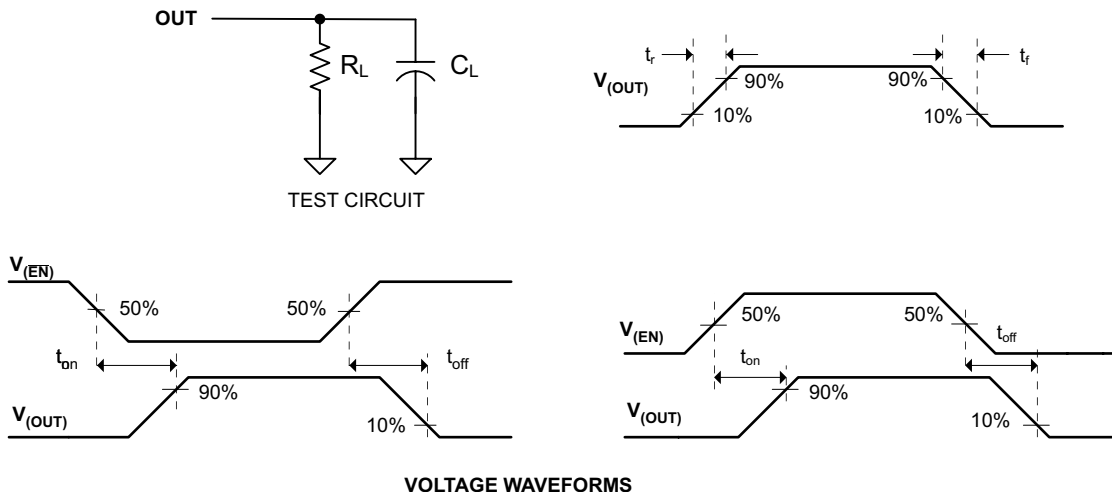


Figure 8-1. Test Circuit and Voltage Waveforms

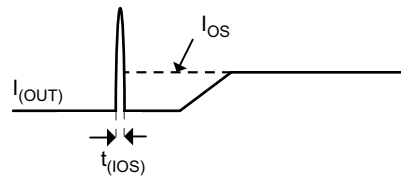


Figure 8-2. Response Time to Short-Circuit Waveform

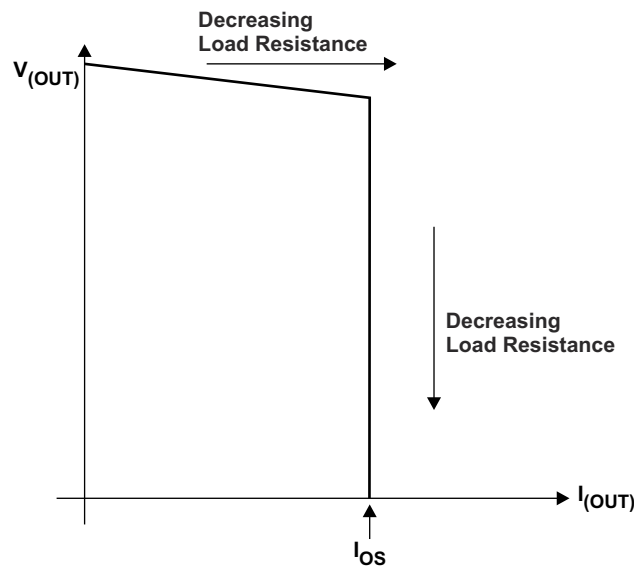


Figure 8-3. Output Voltage Versus Current-Limit Threshold

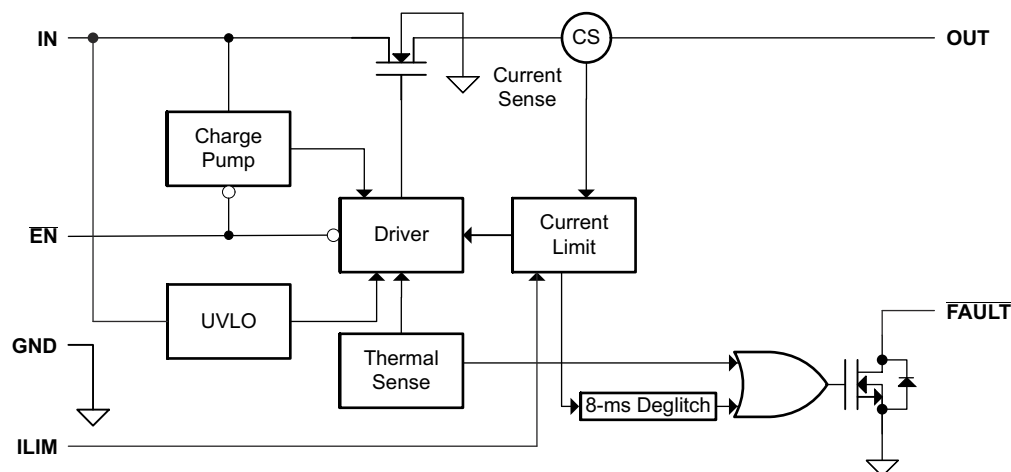
## 8 Detailed Description

### 8.1 Overview

The TPS2556-Q1 and TPS2557-Q1 are current-limited, power-distribution switches using N-channel MOSFETs for applications that might encounter short circuits or heavy capacitive loads. This device allows the user to program the current-limit threshold between 500 mA and 5 A (typical) via an external resistor. This device incorporates an internal charge pump and the gate-drive circuitry necessary to drive the N-channel MOSFET.

The charge pump supplies power to the driver circuit and provides the necessary voltage to pull the gate of the MOSFET above the source. The charge pump operates from input voltages as low as 2.5 V and requires little supply current. The driver controls the gate voltage of the power switch. The driver incorporates circuitry that controls the rise and fall times of the output voltage to limit large current and voltage surges and provides built-in soft-start functionality. The TPS2556-Q1 and TPS2557-Q1 family limits the output current to the programmed current-limit threshold  $I_{OS}$  during an overcurrent or short-circuit event by reducing the charge-pump voltage driving the N-channel MOSFET and operating it in the linear range of operation. The result of limiting the output current to  $I_{OS}$  reduces the output voltage at OUT by no longer fully enhancing the N-channel MOSFET.

## 8.2 Functional Block Diagram



## 8.3 Feature Description

### 8.3.1 Overcurrent Conditions

The TPS2556-Q1 and TPS2557-Q1 devices respond to overcurrent conditions by limiting their output current to  $I_{OS}$ . On detecting an overcurrent condition, the device maintains a constant output current, and the output voltage reduces accordingly. Two possible overload conditions can occur.

The first condition is when a short circuit or partial short circuit is present on a powered-up and enabled device. With the output voltage held near zero potential with respect to ground, the TPS2556-Q1 or TPS2557-Q1 device ramps the output current to  $I_{OS}$ . The TPS2556-Q1 and TPS2557-Q1 devices limit the current to  $I_{OS}$  until removal of the overload condition or until the device begins to cycle thermally.

The second condition is when a short circuit, partial short circuit, or transient overload occurs while the device is enabled and powered on. The device responds to the overcurrent condition within time  $t_{(IOS)}$  (see [Figure 8-2](#)). Overdriving the current-sense amplifier during this time and momentarily disables the internal N-channel MOSFET. The current-sense amplifier recovers and ramps the output current to  $I_{OS}$ . Similar to the previous case, the TPS2556-Q1 and TPS2557-Q1 devices limit the current to  $I_{OS}$  until removal of the overload condition or until the device begins to cycle thermally.

The TPS2556-Q1 and TPS2557-Q1 cycle thermally if an overload condition is present long enough to activate thermal limiting in any of the above cases. The device turns off when the junction temperature exceeds 135°C (minimum) while in current limit. The device remains off until the junction temperature cools 20°C (typical) and then restarts. The TPS2556-Q1 and TPS2557-Q1 cycle on and off until removal of the overload (see [Figure 9-7](#)).

### 8.3.2 FAULT Response

Assertion (active-low) of the  $\overline{\text{FAULT}}$  open-drain output occurs during an overcurrent or overtemperature condition. The TPS2556-Q1 and TPS2557-Q1 devices assert the  $\overline{\text{FAULT}}$  signal until removal of the fault condition and the resumption of normal device operation. Design of the TPS2556-Q1 and TPS2557-Q1 devices eliminates false  $\overline{\text{FAULT}}$  reporting by using an internal delay (9-ms typical) deglitch circuit for overcurrent conditions without the need for external circuitry. This avoids accidental  $\overline{\text{FAULT}}$  assertion due to normal operation, such as starting into a heavy capacitive load. The deglitch circuitry delays entering and leaving current-limit-induced fault conditions. Deglitching of the  $\overline{\text{FAULT}}$  signal does not occur when an overtemperature condition disables the MOSFET, but does occur after the device has cooled and begins to turn on. This unidirectional deglitch prevents  $\overline{\text{FAULT}}$  oscillation during an overtemperature event.

### 8.3.3 Thermal Sense

The TPS2556-Q1 and TPS2557-Q1 devices self-protect by using two independent thermal sensing circuits that monitor the operating temperature of the power switch and disable operation if the temperature exceeds recommended operating conditions. The TPS2556-Q1 and TPS2557-Q1 devices operate in constant-current mode during an overcurrent condition, which increases the voltage drop across power switch. The power

dissipation in the package is proportional to the voltage drop across the power switch, which increases the junction temperature during an overcurrent condition. The first thermal sensor (OTSD) turns off the power switch when the die temperature exceeds 135°C (min) and the part is in current limit. Hysteresis is built into the thermal sensor, and the switch turns on after the device has cooled approximately 20°C.

The TPS2556-Q1 and TPS2557-Q1 devices also have a second thermal sensor (OTSD2). This thermal sensor turns off the power switch when the die temperature exceeds 155°C (minimum) regardless of whether the power switch is in current limit, and turns on the power switch after the device has cooled approximately 20°C. The TPS2556-Q1 and TPS2557-Q1 devices continue to cycle off and on until the fault is removed.

## 8.4 Device Functional Modes

### 8.4.1 Undervoltage Lockout (UVLO)

The undervoltage lockout (UVLO) circuit disables the power switch until the input voltage reaches the UVLO turnon threshold. Built-in hysteresis prevents unwanted on-and-off cycling due to input voltage droop during turnon.

### 8.4.2 Enable ( $\overline{\text{EN}}$ OR EN)

The logic enable controls the power switch and device supply current. The supply current is reduced to less than 2  $\mu\text{A}$  when a logic high is present on  $\overline{\text{EN}}$  or when a logic low is present on EN. A logic low input on  $\overline{\text{EN}}$  or a logic high input on EN enables the driver, control circuits, and power switch. The enable input is compatible with both TTL and CMOS logic levels.

### 8.4.3 Auto-Retry Functionality

Some applications require that an overcurrent condition disable the device momentarily during a fault condition and re-enables it after a preset time. This *auto-retry* functionality can be implemented with an external resistor and capacitor. During a fault condition,  $\overline{\text{FAULT}}$  pulls EN low. Pulling EN below the turnoff threshold disables the part is disabled, and  $\overline{\text{FAULT}}$  goes into the high-impedance state, allowing  $C_{\text{RETRY}}$  to begin charging. The device re-enables when the voltage on EN reaches the turnon threshold. The resistor-capacitor time constant determines the auto-retry time. The device continues to cycle in this manner until removal of the fault condition.

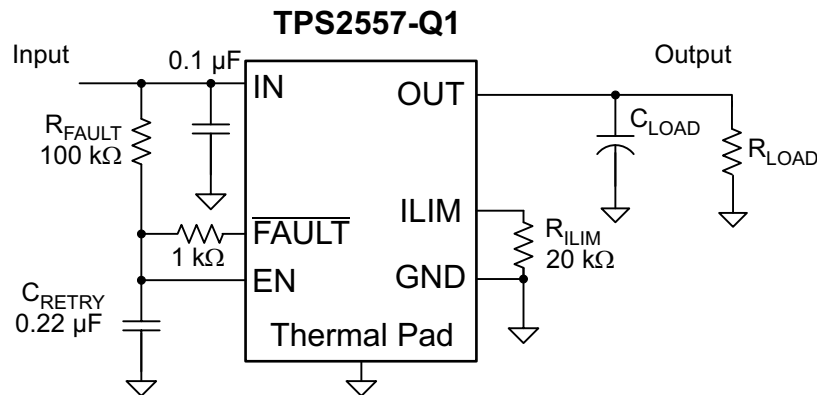
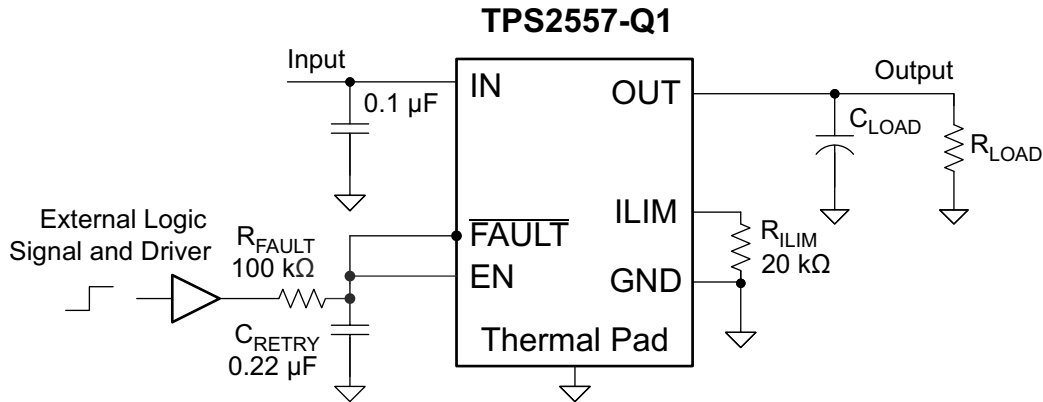


Figure 8-1. Auto-Retry Functionality

Some applications require auto-retry functionality and the ability to enable and disable with an external logic signal. Figure 8-2 shows how an external logic signal can drive EN through  $R_{\text{FAULT}}$  and maintain auto-retry functionality. The resistor-capacitor time constant determines the auto-retry time-out period.



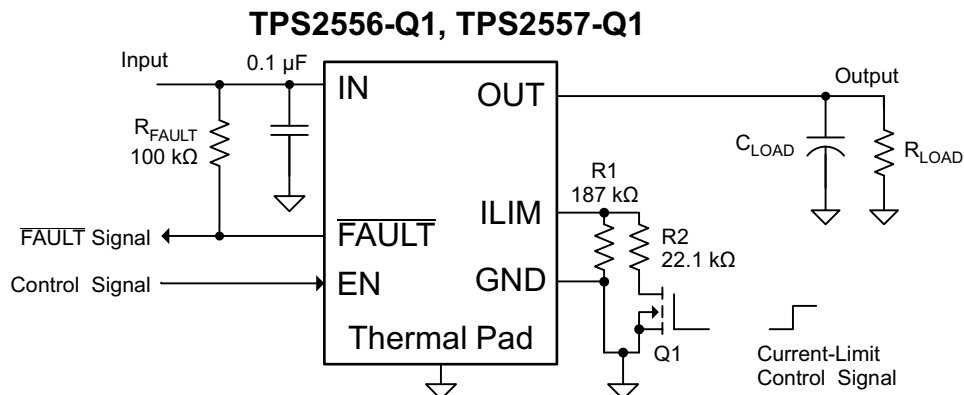
**Figure 8-2. Auto-Retry Functionality With External EN Signal**

#### 8.4.4 Two-Level Current-Limit Circuit

Some applications require different current-limit thresholds depending on external system conditions. [Figure 8-3](#) shows an implementation for an externally controlled, two-level current-limit circuit. The current-limit threshold is set by the total resistance from ILIM to GND (see [Programming the Current-Limit Threshold](#)). A logic-level input enables and disables MOSFET Q1 and changes the current-limit threshold by modifying the total resistance from ILIM to GND. One can use additional MOSFET and resistor combinations in parallel with Q1 and R2 to increase the number of additional current-limit levels.

#### CAUTION

Never drive ILIM directly with an external signal.



**Figure 8-3. Two-Level Current-Limit Circuit**

## 9 Applications and Implementation

### Note

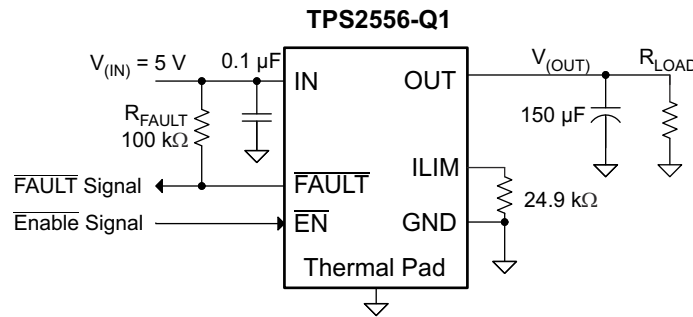
Information in the following applications sections is not part of the TI component specification, and TI does not warrant its accuracy or completeness. TI's customers are responsible for determining suitability of components for their purposes, as well as validating and testing their design implementation to confirm system functionality.

### 9.1 Application Information

The devices are current-limited, power-distribution switches. They limit the output current to  $I_{OS}$  when encountering short circuits or heavy capacitive loads.

### 9.2 Typical Application, Design for Current Limit

The use of the TPS2556-Q1 and TPS2557-Q1 devices is as a power switch to limit the output current.  $\overline{\text{FAULT}}$  is an open drain pulled high to  $V_{(IN)}$  with a resistor, a host can use to monitor overcurrent or thermal shutdown.



**Figure 9-1. Application Schematic for Current Limit, TPS2556-Q1**

#### 9.2.1 Design Requirements

For this design example, use the following as the input parameters.

**Table 9-1. Design Parameters**

DESIGN PARAMETER	EXAMPLE VALUE
Input voltage	5 V
Minimum current limit	3 A
Maximum current limit	5 A

#### 9.2.2 Detailed Design Procedure

##### 9.2.2.1 Determine Design Parameters

Beginning the design process requires deciding on a few parameters. The designer must know the following:

- Input voltage
- Minimum current limit
- Maximum current limit

##### 9.2.2.2 Programming the Current-Limit Threshold

The overcurrent threshold is user-programmable via an external resistor. The TPS2556-Q1 and TPS2557-Q1 devices use an internal regulation loop to provide a regulated voltage on the ILIM terminal. The current-limit threshold is proportional to the current sourced out of ILIM. The recommended 1% resistor range for  $R_{ILIM}$  is  $20 \text{ k}\Omega \leq R_{(ILIM)} \leq 187 \text{ k}\Omega$  to ensure stability of the internal regulation loop. Many applications require that the minimum current limit be above a certain current level or that the maximum current limit be below a certain current level, so it is important to consider the tolerance of the overcurrent threshold when selecting a value for  $R_{ILIM}$ . The following equations approximate the resulting overcurrent threshold for a given value of external

resistor  $R_{ILIM}$ . Consult the [Electrical Characteristics](#) table for specific current-limit settings. The traces routing the  $R_{ILIM}$  resistor to the TPS2556-Q1 and TPS2557-Q1 devices should be as short as possible to reduce parasitic effects on the current-limit accuracy.

$$\begin{aligned}
 I_{OS(max)}(mA) &= \frac{101\,810\text{ V}}{R_{(ILIM)}^{0.9538}\text{ k}\Omega} \\
 I_{OS(nom)}(mA) &= \frac{113\,849\text{ V}}{R_{(ILIM)}^{1.0049}\text{ k}\Omega} \\
 I_{OS(min)}(mA) &= \frac{125\,477\text{ V}}{R_{(ILIM)}^{1.058}\text{ k}\Omega}
 \end{aligned} \tag{1}$$

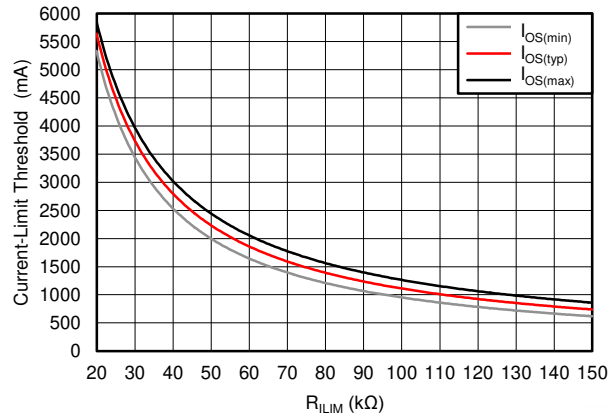


Figure 9-2. Current-Limit Threshold versus  $R_{ILIM}$

### 9.2.2.3 Selecting Current-Limit Resistor 1

Some applications require that current limiting not occur below a certain threshold. For this example, assume that 3 A must be delivered to the load so that the minimum desired current-limit threshold is 3 000 mA. Use the  $I_{OS}$  equations and [Figure 9-2](#) to select  $R_{ILIM}$ .

$$\begin{aligned}
 I_{OS(min)}(mA) &= 3\,000\text{ mA} \\
 I_{OS(min)}(mA) &= \frac{125\,477\text{ V}}{R_{(ILIM)}^{1.058}\text{ k}\Omega} \\
 R_{(ILIM)}(k\Omega) &= \left( \frac{125\,477\text{ V}}{I_{OS(min)}\text{ mA}} \right)^{\frac{1}{1.058}} \\
 R_{(ILIM)}(k\Omega) &= 34\text{ k}\Omega
 \end{aligned} \tag{2}$$

Select the closest 1% resistor less than the calculated value:  $R_{ILIM} = 33.6\text{ k}\Omega$ . This sets the minimum current-limit threshold at 3 000 mA. Use the  $I_{OS}$  equations, [Figure 10-2](#), and the previously calculated value for  $R_{ILIM}$  to calculate the maximum resulting current-limit threshold.

$$\begin{aligned}
 R_{ILIM}(k\Omega) &= 33.6\text{ k}\Omega \\
 I_{OS(max)}(mA) &= \frac{101\,810\text{ V}}{R_{(ILIM)}^{0.9538}\text{ k}\Omega} \\
 I_{OS(max)}(mA) &= \frac{101\,810\text{ V}}{33.6^{0.9538}\text{ k}\Omega} \\
 I_{OS(max)}(mA) &= 3\,564\text{ mA}
 \end{aligned} \tag{3}$$

The resulting maximum current-limit threshold is 3 564 mA with a 33.6-kΩ resistor.

### 9.2.2.4 Selecting Current-Limit Resistor 2

Some applications require that current limiting must occur below a certain threshold. For this example, assume that the desired upper current-limit threshold must be below 5,000 mA to protect an upstream power supply. Use the  $I_{OS}$  equations and [Figure 9-2](#) to select  $R_{(ILIM)}$ .

$$\begin{aligned}
 I_{OS(max)}(mA) &= 5\,000\text{ mA} \\
 I_{OS(max)}(mA) &= \frac{101\,810\text{ V}}{R_{(ILIM)}^{0.9538}\text{ k}\Omega} \\
 R_{(ILIM)}(k\Omega) &= \left( \frac{101\,810\text{ V}}{I_{OS(max)}\text{ mA}} \right)^{\frac{1}{0.9538}} \\
 R_{(ILIM)}(k\Omega) &= 23.6\text{ k}\Omega
 \end{aligned} \tag{4}$$

Select the closest 1% resistor greater than the calculated value:  $R_{(ILIM)} = 23.7\text{ k}\Omega$ . This sets the maximum current-limit threshold at 5 000 mA . Use the  $I_{OS}$  equations, [Figure 10-2](#), and the previously calculated value for  $R_{(ILIM)}$  to calculate the minimum resulting current-limit threshold.

$$\begin{aligned}
 R_{(ILIM)}(k\Omega) &= 23.7\text{ k}\Omega \\
 I_{OS(min)}(mA) &= \frac{125\,477\text{ V}}{R_{(ILIM)}^{1.058}} \\
 I_{OS(min)}(mA) &= \frac{125\,477\text{ V}}{23.7^{1.058}} \\
 I_{OS(min)}(mA) &= 4\,406\text{ mA}
 \end{aligned} \tag{5}$$

The resulting minimum current-limit threshold is 4 406 mA with a 23.7-k $\Omega$  resistor.

### 9.2.2.5 Accounting for Resistor Tolerance

The previous sections described the selection of  $R_{(ILIM)}$  given certain application requirements and the importance of understanding the current-limit threshold tolerance. The analysis focused only on the TPS2556-Q1 and TPS2557-Q1 device performance and assumed an exact resistor value. However, resistors sold in quantity are not exact and are bounded by an upper and lower tolerance centered around a nominal resistance. The additional  $R_{(ILIM)}$  resistance tolerance directly affects the current-limit threshold accuracy at a system level. The following table shows a process that accounts for worst-case resistor tolerance assuming 1% resistor values. Step one follows the selection process outlined in the foregoing application examples. Step two determines the upper and lower resistance bounds of the selected resistor. Step three uses the upper and lower resistor bounds in the  $I_{OS}$  equations to calculate the threshold limits. It is important to use tighter tolerance resistors, for example 0.5% or 0.1%, when precision current limiting is desirable.

**Table 9-2. Common R<sub>ILIM</sub> Resistor Selections**

Desired Nominal Current Limit (mA)	Ideal Resistor (kΩ)	Closest 1% Resistor (kΩ)	Resistor Tolerance		Actual Limits		
			1% low (kΩ)	1% high (kΩ)	I <sub>OS</sub> MIN (mA)	I <sub>OS</sub> NOM (mA)	I <sub>OS</sub> MAX (mA)
750	148.1	147	145.5	148.5	632	756	881
1000	111.3	110	108.9	111.1	859	1011	1161
1250	89.1	88.7	87.8	89.6	1079	1256	1426
1500	74.3	75	74.3	75.8	1289	1486	1673
1750	63.7	63.4	62.8	64.0	1540	1760	1964
2000	55.8	56.2	55.6	56.8	1749	1986	2203
2250	49.6	49.9	49.4	50.4	1983	2238	2468
2500	44.7	44.2	43.8	44.6	2255	2528	2770
2750	40.7	40.2	39.8	40.6	2493	2781	3033
3000	37.3	37.4	37.0	37.8	2691	2991	3249
3250	34.4	34.8	34.5	35.1	2904	3215	3480
3500	32.0	31.6	31.3	31.9	3216	3542	3816
3750	29.9	30.1	29.8	30.4	3386	3720	3997
4000	28.0	28	27.7	28.3	3655	4000	4282
4250	26.4	26.1	25.8	26.4	3937	4293	4579
4500	24.9	24.9	24.7	25.1	4138	4501	4789
4750	23.6	23.7	23.5	23.9	4360	4730	5020
5000	22.4	22.6	22.4	22.8	4585	4961	5253
5250	21.4	21.5	21.3	21.7	4834	5216	5509
5500	20.4	20.5	20.3	20.7	5083	5472	5765

### 9.2.2.6 Power Dissipation and Junction Temperature

The low on-resistance of the N-channel MOSFET allows small surface-mount packages to pass large currents. It is good design practice to estimate power dissipation and junction temperature. The following analysis gives an approximation for calculating junction temperature based on the power dissipation in the package. However, it is important to note that thermal analysis is strongly dependent on additional system-level factors. Such factors include air flow, board layout, copper thickness and surface area, and proximity to other devices that dissipate power. Good thermal design practice must include all system-level factors in addition to individual component analysis.

Begin by determining the  $r_{DS(on)}$  of the N-channel MOSFET relative to the input voltage and operating temperature. As an initial estimate, use the highest operating ambient temperature of interest and read  $r_{DS(on)}$  from the typical characteristics graph. Using this value, calculate the power dissipation by:

$$P_D = r_{DS(on)} \times I_{OUT}^2$$

where:

$P_D$  = Total power dissipation (W)

$r_{DS(on)}$  = Power-switch on-resistance (Ω)

$I_{(OUT)}$  = Maximum current-limit threshold (A)

This step calculates the total power dissipation of the N-channel MOSFET.

Finally, calculate the junction temperature:

$$T_J = P_D \times R_{\theta JA} + T_A$$

where:

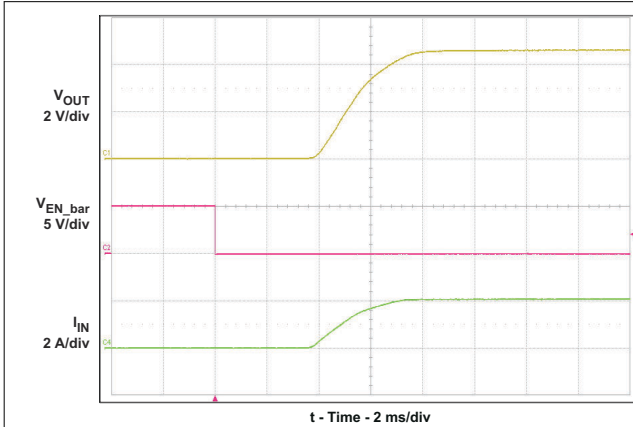
$T_A$  = Ambient temperature (°C)

$R_{\theta JA}$  = Thermal resistance ( $^{\circ}\text{C}/\text{W}$ )

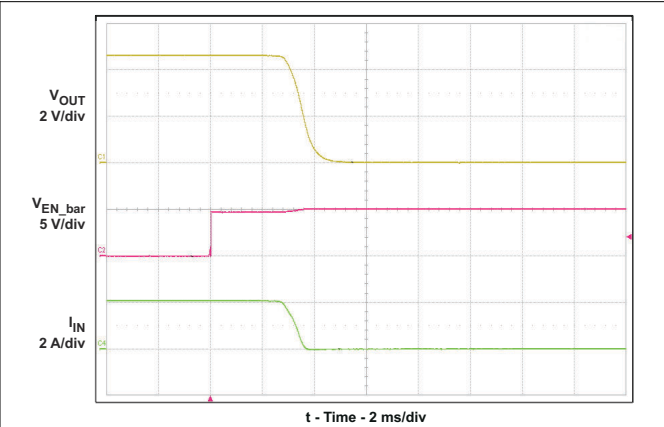
$P_D$  = Total power dissipation (W)

Compare the calculated junction temperature with the initial estimate. If they are not within a few degrees, repeat the calculation using the *refined*  $r_{DS(on)}$  from the previous calculation as the new estimate. Two or three iterations are generally sufficient to achieve the desired result. The final junction temperature is highly dependent on thermal resistance  $R_{\theta JA}$ , and thermal resistance is highly dependent on the individual package and board layout. The [Thermal Information table](#) lists thermal resistances of the device that one can use to help calculate the thermal performance of the board design.

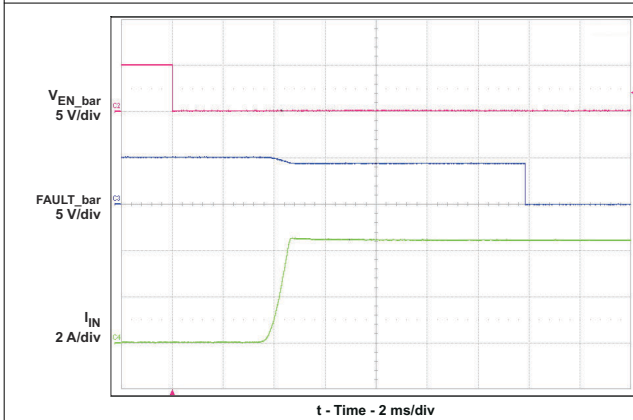
### 9.2.3 Application Curves



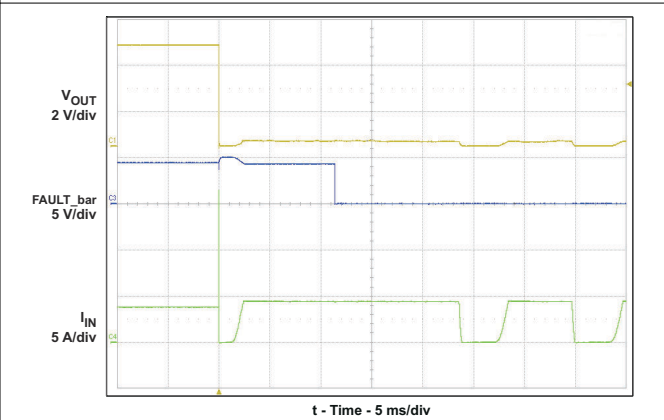
**Figure 9-3. Turnon Delay and Rise Time**



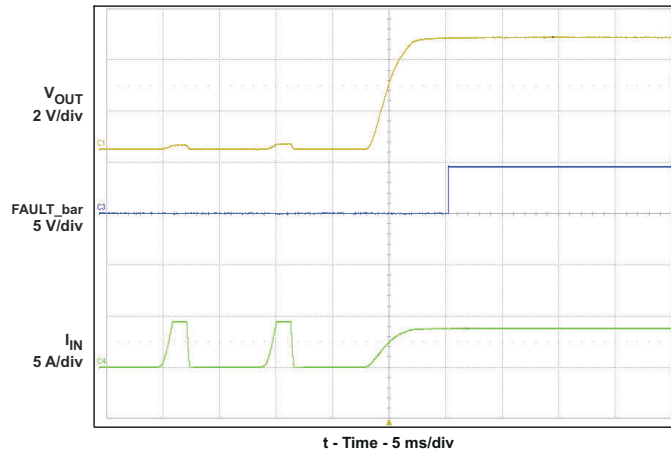
**Figure 9-4. Turnoff Delay and Fall Time**



**Figure 9-5. Device Enabled Into Short Circuit**



**Figure 9-6. Full-Load to Short-Circuit Transient Response**



**Figure 9-7. Short-Circuit to Full-Load Recovery Response**

## 10 Power Supply Recommendations

Design of the devices is for operation from an input voltage supply range of 2.5 V to 6.5 V. The current capability of the power supply should exceed the maximum current limit of the power switch.

## 11 Layout

### 11.1 Layout Guidelines

- For all applications, TI recommends a 0.1- $\mu\text{F}$  or greater ceramic bypass capacitor between IN and GND as close to the device as possible for local noise decoupling. This precaution reduces ringing on the input due to power-supply transients. The application may require additional input capacitance on the input to prevent voltage overshoot from exceeding the absolute-maximum voltage of the device during heavy transient conditions.
- Output capacitance is not required, but TI recommends placing a high-value electrolytic capacitor on the output pin when there is an expectation of large transient currents on the output.
- The traces routing the  $R_{\text{ILIM}}$  resistor to the device should be as short as possible to reduce parasitic effects on the current limit accuracy.
- Connect the thermal pad directly to PCB ground plane using wide and short copper trace.

### 11.2 Layout Example

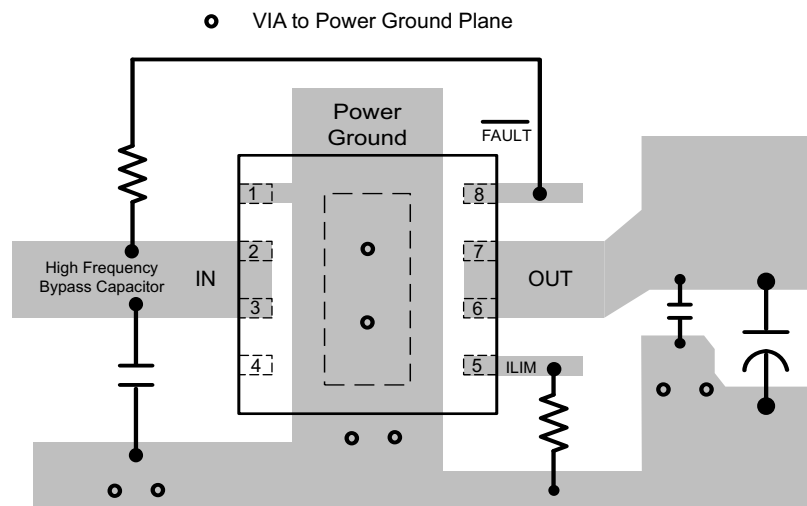


Figure 11-1. TPS2556-Q1 and TPS2557-Q1 Board Layout

## 12 Device and Documentation Support

### 12.1 Related Links

The following table lists quick access links. Categories include technical documents, support and community resources, tools and software, and quick access to sample or buy.

**Table 12-1. Related Links**

PARTS	PRODUCT FOLDER	SAMPLE & BUY	TECHNICAL DOCUMENTS	TOOLS & SOFTWARE	SUPPORT & COMMUNITY
TPS2556-Q1	<a href="#">Click here</a>	<a href="#">Click here</a>	<a href="#">Click here</a>	<a href="#">Click here</a>	<a href="#">Click here</a>
TPS2557-Q1	<a href="#">Click here</a>	<a href="#">Click here</a>	<a href="#">Click here</a>	<a href="#">Click here</a>	<a href="#">Click here</a>

### 12.2 Trademarks

All trademarks are the property of their respective owners.

### 12.3 Electrostatic Discharge Caution



This integrated circuit can be damaged by ESD. Texas Instruments recommends that all integrated circuits be handled with appropriate precautions. Failure to observe proper handling and installation procedures can cause damage.

ESD damage can range from subtle performance degradation to complete device failure. Precision integrated circuits may be more susceptible to damage because very small parametric changes could cause the device not to meet its published specifications.

### 12.4 Glossary

[TI Glossary](#)

This glossary lists and explains terms, acronyms, and definitions.

## 13 Mechanical, Packaging, and Orderable Information

The following packaging information and addendum reflect the most-current data available for the designated devices. This data is subject to change without notice and without revision of this document.

**PACKAGING INFORMATION**

Orderable Device	Status (1)	Package Type	Package Drawing	Pins	Package Qty	Eco Plan (2)	Lead finish/ Ball material (6)	MSL Peak Temp (3)	Op Temp (°C)	Device Marking (4/5)	Samples
TPS2556QDRBRQ1	ACTIVE	SON	DRB	8	3000	RoHS & Green	NIPDAU	Level-2-260C-1 YEAR	-40 to 125	2556Q	<a href="#">Samples</a>
TPS2556QDRBTQ1	ACTIVE	SON	DRB	8	250	RoHS & Green	NIPDAU	Level-2-260C-1 YEAR	-40 to 125	2556Q	<a href="#">Samples</a>
TPS2557QDRBRQ1	ACTIVE	SON	DRB	8	3000	RoHS & Green	NIPDAU	Level-2-260C-1 YEAR	-40 to 125	2557Q	<a href="#">Samples</a>
TPS2557QDRBTQ1	ACTIVE	SON	DRB	8	250	RoHS & Green	NIPDAU	Level-2-260C-1 YEAR	-40 to 125	2557Q	<a href="#">Samples</a>

(1) The marketing status values are defined as follows:

**ACTIVE:** Product device recommended for new designs.

**LIFEBUY:** TI has announced that the device will be discontinued, and a lifetime-buy period is in effect.

**NRND:** Not recommended for new designs. Device is in production to support existing customers, but TI does not recommend using this part in a new design.

**PREVIEW:** Device has been announced but is not in production. Samples may or may not be available.

**OBSOLETE:** TI has discontinued the production of the device.

(2) **RoHS:** TI defines "RoHS" to mean semiconductor products that are compliant with the current EU RoHS requirements for all 10 RoHS substances, including the requirement that RoHS substance do not exceed 0.1% by weight in homogeneous materials. Where designed to be soldered at high temperatures, "RoHS" products are suitable for use in specified lead-free processes. TI may reference these types of products as "Pb-Free".

**RoHS Exempt:** TI defines "RoHS Exempt" to mean products that contain lead but are compliant with EU RoHS pursuant to a specific EU RoHS exemption.

**Green:** TI defines "Green" to mean the content of Chlorine (Cl) and Bromine (Br) based flame retardants meet JS709B low halogen requirements of <=1000ppm threshold. Antimony trioxide based flame retardants must also meet the <=1000ppm threshold requirement.

(3) **MSL, Peak Temp.** - The Moisture Sensitivity Level rating according to the JEDEC industry standard classifications, and peak solder temperature.

(4) There may be additional marking, which relates to the logo, the lot trace code information, or the environmental category on the device.

(5) Multiple Device Markings will be inside parentheses. Only one Device Marking contained in parentheses and separated by a "-" will appear on a device. If a line is indented then it is a continuation of the previous line and the two combined represent the entire Device Marking for that device.

(6) **Lead finish/Ball material** - Orderable Devices may have multiple material finish options. Finish options are separated by a vertical ruled line. Lead finish/Ball material values may wrap to two lines if the finish value exceeds the maximum column width.

**Important Information and Disclaimer:** The information provided on this page represents TI's knowledge and belief as of the date that it is provided. TI bases its knowledge and belief on information provided by third parties, and makes no representation or warranty as to the accuracy of such information. Efforts are underway to better integrate information from third parties. TI has taken and

continues to take reasonable steps to provide representative and accurate information but may not have conducted destructive testing or chemical analysis on incoming materials and chemicals. TI and TI suppliers consider certain information to be proprietary, and thus CAS numbers and other limited information may not be available for release.

In no event shall TI's liability arising out of such information exceed the total purchase price of the TI part(s) at issue in this document sold by TI to Customer on an annual basis.

**OTHER QUALIFIED VERSIONS OF TPS2556-Q1, TPS2557-Q1 :**

- Catalog: [TPS2556](#), [TPS2557](#)

**NOTE: Qualified Version Definitions:**

- Catalog - TI's standard catalog product

**TAPE AND REEL INFORMATION**

**QUADRANT ASSIGNMENTS FOR PIN 1 ORIENTATION IN TAPE**


\*All dimensions are nominal

Device	Package Type	Package Drawing	Pins	SPQ	Reel Diameter (mm)	Reel Width W1 (mm)	A0 (mm)	B0 (mm)	K0 (mm)	P1 (mm)	W (mm)	Pin1 Quadrant
TPS2556QDRBRQ1	SON	DRB	8	3000	330.0	12.4	3.3	3.3	1.1	8.0	12.0	Q2
TPS2556QDRBTQ1	SON	DRB	8	250	180.0	12.4	3.3	3.3	1.1	8.0	12.0	Q2
TPS2557QDRBRQ1	SON	DRB	8	3000	330.0	12.4	3.3	3.3	1.1	8.0	12.0	Q2
TPS2557QDRBTQ1	SON	DRB	8	250	180.0	12.4	3.3	3.3	1.1	8.0	12.0	Q2

**TAPE AND REEL BOX DIMENSIONS**


\*All dimensions are nominal

Device	Package Type	Package Drawing	Pins	SPQ	Length (mm)	Width (mm)	Height (mm)
TPS2556QDRBRQ1	SON	DRB	8	3000	346.0	346.0	33.0
TPS2556QDRBTQ1	SON	DRB	8	250	210.0	185.0	35.0
TPS2557QDRBRQ1	SON	DRB	8	3000	346.0	346.0	33.0
TPS2557QDRBTQ1	SON	DRB	8	250	210.0	185.0	35.0

**DRB 8**

**GENERIC PACKAGE VIEW**

**VSON - 1 mm max height**

PLASTIC SMALL OUTLINE - NO LEAD



Images above are just a representation of the package family, actual package may vary.  
Refer to the product data sheet for package details.

4203482/L

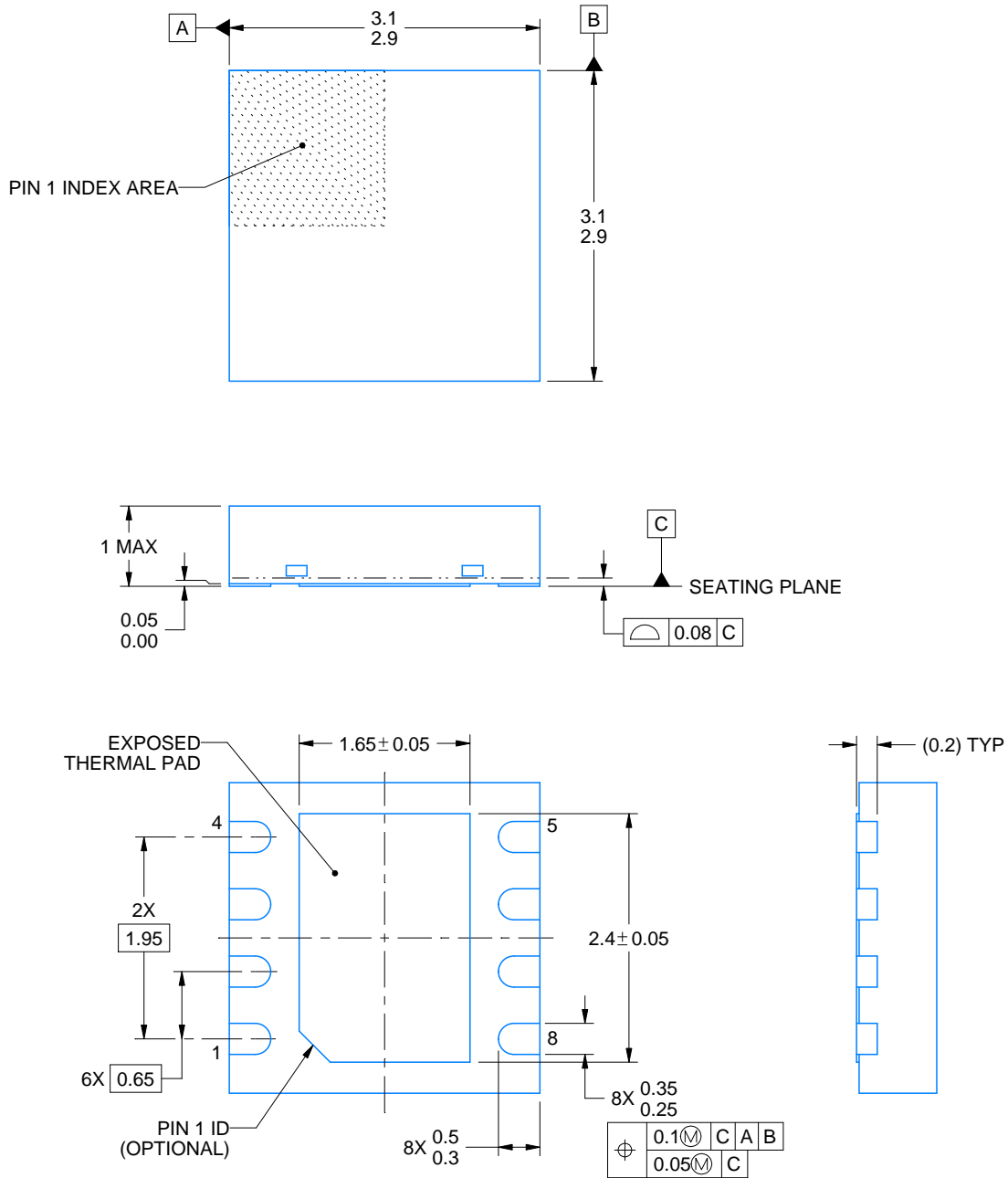
DRB0008B



# PACKAGE OUTLINE

VSON - 1 mm max height

PLASTIC SMALL OUTLINE - NO LEAD



4218876/A 12/2017

**NOTES:**

1. All linear dimensions are in millimeters. Any dimensions in parenthesis are for reference only. Dimensioning and tolerancing per ASME Y14.5M.
2. This drawing is subject to change without notice.
3. The package thermal pad must be soldered to the printed circuit board for thermal and mechanical performance.

# EXAMPLE BOARD LAYOUT

DRB0008B

VSON - 1 mm max height

PLASTIC SMALL OUTLINE - NO LEAD



LAND PATTERN EXAMPLE  
SCALE:20X



SOLDER MASK DETAILS

4218876/A 12/2017

NOTES: (continued)

4. This package is designed to be soldered to a thermal pad on the board. For more information, see Texas Instruments literature number SLUA271 ([www.ti.com/lit/sluea271](http://www.ti.com/lit/sluea271)).
5. Vias are optional depending on application, refer to device data sheet. If any vias are implemented, refer to their locations shown on this view. It is recommended that vias under paste be filled, plugged or tented.

# EXAMPLE STENCIL DESIGN

DRB0008B

VSON - 1 mm max height

PLASTIC SMALL OUTLINE - NO LEAD



SOLDER PASTE EXAMPLE  
BASED ON 0.125 mm THICK STENCIL

EXPOSED PAD  
81% PRINTED SOLDER COVERAGE BY AREA  
SCALE:25X

4218876/A 12/2017

NOTES: (continued)

6. Laser cutting apertures with trapezoidal walls and rounded corners may offer better paste release. IPC-7525 may have alternate design recommendations.

## IMPORTANT NOTICE AND DISCLAIMER

TI PROVIDES TECHNICAL AND RELIABILITY DATA (INCLUDING DATA SHEETS), DESIGN RESOURCES (INCLUDING REFERENCE DESIGNS), APPLICATION OR OTHER DESIGN ADVICE, WEB TOOLS, SAFETY INFORMATION, AND OTHER RESOURCES "AS IS" AND WITH ALL FAULTS, AND DISCLAIMS ALL WARRANTIES, EXPRESS AND IMPLIED, INCLUDING WITHOUT LIMITATION ANY IMPLIED WARRANTIES OF MERCHANTABILITY, FITNESS FOR A PARTICULAR PURPOSE OR NON-INFRINGEMENT OF THIRD PARTY INTELLECTUAL PROPERTY RIGHTS.

These resources are intended for skilled developers designing with TI products. You are solely responsible for (1) selecting the appropriate TI products for your application, (2) designing, validating and testing your application, and (3) ensuring your application meets applicable standards, and any other safety, security, regulatory or other requirements.

These resources are subject to change without notice. TI grants you permission to use these resources only for development of an application that uses the TI products described in the resource. Other reproduction and display of these resources is prohibited. No license is granted to any other TI intellectual property right or to any third party intellectual property right. TI disclaims responsibility for, and you will fully indemnify TI and its representatives against, any claims, damages, costs, losses, and liabilities arising out of your use of these resources.

TI's products are provided subject to [TI's Terms of Sale](#) or other applicable terms available either on [ti.com](https://www.ti.com) or provided in conjunction with such TI products. TI's provision of these resources does not expand or otherwise alter TI's applicable warranties or warranty disclaimers for TI products.

TI objects to and rejects any additional or different terms you may have proposed.

Mailing Address: Texas Instruments, Post Office Box 655303, Dallas, Texas 75265  
Copyright © 2023, Texas Instruments Incorporated

## Looking for pricing, stock, or lifecycle information?

Click below to explore more details on WIN SOURCE:

 [View TPS2557QDRBTQ1 on WIN SOURCE](#)

 [Texas Instruments](#) Information

## Optimize Your Supply Chain with WIN SOURCE Solutions

-  Global Sourcing Solution
-  Obsolete Management
-  Cost Control Management
-  Shortage Management
-  Alternative Solution
-  Excess Inventory Management