

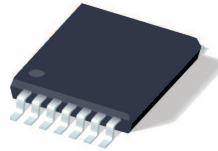

THE DATASHEET OF TPS2350EVM





Hot Swap Power Manager for Redundant –48-V Supplies

 Check for Samples: [TPS2350](#)

FEATURES

- Replaces OR-ing Diodes
- Operating Supply Range of –12 V to –80 V
- Withstands Transients to –100 V
- Programmable Current Limit
- Programmable Linear Inrush Slew Rate
- Programmable UV/OV Thresholds
- Programmable UV and OV Hysteresis
- Fault Timer to Eliminate Nuisance Trips
- Power Good and Fault Outputs
- 14-Pin SOIC and TSSOP Package

APPLICATIONS

- –48-V Distributed Power Systems
- Central Office Switching
- ONET
- Base Stations

DESCRIPTION

The TPS2350 is a hot swap power manager optimized for replacing OR-ing diodes in redundant power –48-V systems. The TPS2350 operates with supply voltages from –12 V to –80 V, and withstands spikes to –100 V.

The TPS2350 uses two power FETs as low voltage drop diodes to efficiently select between two redundant power supplies. This minimizes system power dissipation and also minimizes voltage drop through the power management chain.

The TPS2350 also uses a third power FET to provide load current slew rate control and peak current limiting that is programmed by one resistor and one capacitor. The device also provides a power good output to enable down-stream power converters and a fault output to indicate load problems.

TYPICAL APPLICATION DIAGRAM

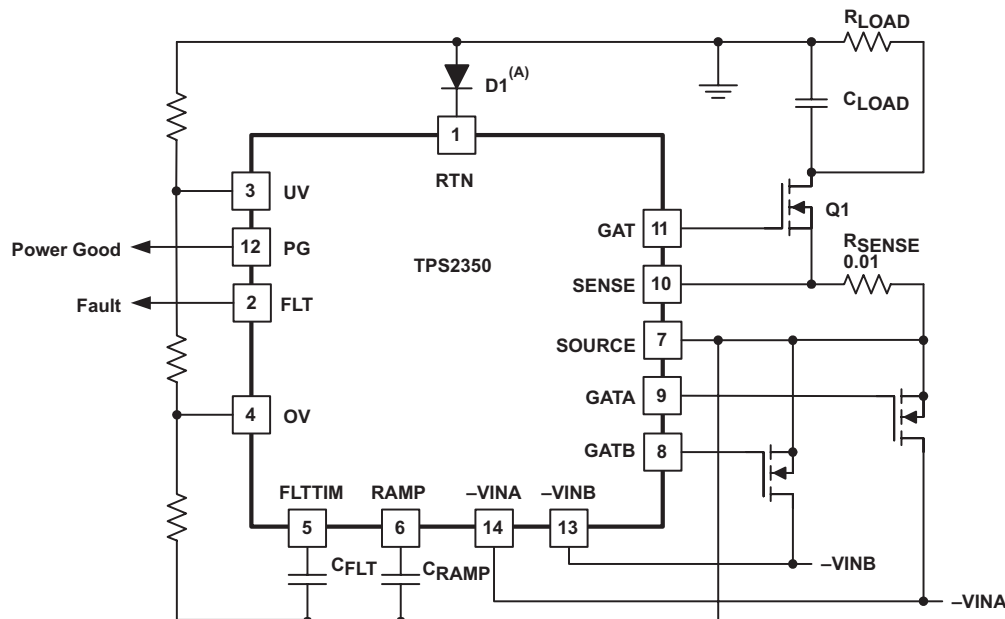

A. D1 optional per application requirements.



Please be aware that an important notice concerning availability, standard warranty, and use in critical applications of Texas Instruments semiconductor products and disclaimers thereto appears at the end of this data sheet.



These devices have limited built-in ESD protection. The leads should be shorted together or the device placed in conductive foam during storage or handling to prevent electrostatic damage to the MOS gates.

ABSOLUTE MAXIMUM RATINGS

over operating free-air temperature (unless otherwise noted)⁽¹⁾

| | | VALUE | UNIT |
|--|----------------------------|-----------------------------------|------|
| Input voltage range, RTN ⁽²⁾ | | -0.3 to 100 | V |
| Input voltage range, -VINA to -VINB | | -100 to 100 | |
| Input voltage range, FLTTIM, RAMP, SENSE, OV, UV ⁽²⁾ | | -0.3 to 15 | |
| Output voltage range, $\overline{\text{FLT}}$, PG ⁽²⁾⁽³⁾ | | -0.3 to 100 | |
| Continuous output current, $\overline{\text{FLT}}$, PG | | 10 | mA |
| Continuous total power dissipation | | See the Thermal Information table | |
| Electrostatic Discharge | Human body model (HBM) | 2 | kV |
| | Charged device model (CDM) | 1.5 | |
| Operating junction temperature range, T _J | | -55 to 125 | °C |
| Storage temperature range, T _{stg} | | -65 to 150 | |

- (1) Stresses beyond those listed under “absolute maximum ratings” may cause permanent damage to the device. These are stress ratings only, and functional operation of the device at these or any other conditions beyond those indicated under “recommended operating conditions” is not implied. Exposure to absolute-maximum-rated conditions for extended periods may affect device reliability.
- (2) All voltages are with respect to the more negative of -VINA and -VINB (unless otherwise noted).
- (3) With 10 kΩ minimum series resistance. Range limited to -0.3V to 80V from low impedance source.

SOIC/TSSOP-14 PACKAGE (TOP VIEW)

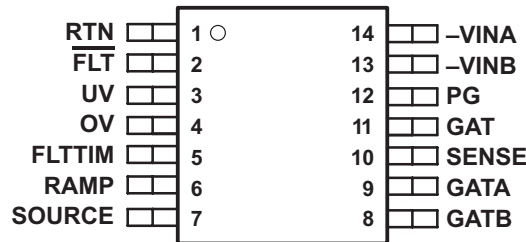

Device Information

| T _A | PACKAGE ⁽¹⁾ | PART NUMBER |
|----------------|-------------------------|-------------|
| -40°C to 85°C | SOIC-14 ⁽²⁾ | TPS2350D |
| | TSSOP-14 ⁽²⁾ | TPS2350PW |

- (1) For the most current package and ordering information, see the Package Option Addendum at the end of this document, or see the TI web site at www.ti.com.
- (2) The D and PW packages are also available taped and reeled. Add an R suffix to the device type (i.e. TPS2350DR).

RECOMMENDED OPERATING CONDITIONS

| | MIN | NOM | MAX | UNIT |
|--------------------------------------|-----|-----|-----|------|
| Input supply, -VINA, -VINB to RTN | -80 | -48 | -12 | V |
| Operating junction temperature range | -40 | | 85 | °C |

THERMAL INFORMATION

| THERMAL METRIC ⁽¹⁾ | | TPS2350 | | UNITS |
|-------------------------------|--|-------------|--------------|-------|
| | | D (14 PINS) | PW (14 PINS) | |
| θ_{JA} | Junction-to-ambient thermal resistance | 95.9 | 120.8 | °C/W |
| θ_{JB} | Junction-to-board thermal resistance | 51.5 | 62.8 | |
| θ_{JCTop} | Junction-to-case (top) thermal resistance | 50.7 | n/a | |
| ψ_{JT} | Junction-to-top characterization parameter | 8.3 | 1 | |
| ψ_{JB} | Junction-to-board characterization parameter | 51.1 | 56.5 | |

(1) For more information about traditional and new thermal metrics, see the *IC Package Thermal Metrics* application report, [SPRA953](#).

ELECTRICAL CHARACTERISTICS

–VINA = –48 V, –VINB = 0 V, UV = 2.5 V, OV = 0.5 V, SENSE = 0 V, RAMP = 0 V, SOURCE = more negative of –VINA and –VINB, all outputs unloaded, $T_A = -40^{\circ}\text{C}$ to 85°C (unless otherwise noted)⁽¹⁾⁽²⁾

| PARAMETER | | TEST CONDITIONS | MIN | TYP | MAX | UNIT |
|--|---|--|-------|-------|-------|---------------|
| Input Supply | | | | | | |
| I_{CC1A} | Supply current | –VINA = –48 V, –VINB = 0 V | | 1000 | 1500 | μA |
| I_{CC2A} | Supply current | –VINA = –80 V, –VINB = 0 V | | | 2000 | |
| I_{CC1B} | Supply current | –VINB = –48 V, –VINA = 0 V | | 1000 | 1500 | |
| I_{CC2B} | Supply current | –VINB = –80 V, –VINA = 0 V | | | 2000 | |
| V_{UVLO_I} | Internal UVLO threshold voltage | To GAT pull up | –11.8 | –10 | –8.0 | V |
| V_{HYST} | Internal UVLO hysteresis voltage | | 50 | 240 | 500 | mV |
| Overvoltage and Undervoltage Inputs (OV and UV) | | | | | | |
| V_{THUV} | UV threshold voltage, UV rising, to –VINA | To GAT pull up, 25°C | 1.391 | 1.400 | 1.409 | V |
| | | To GAT pull up, 0 to 70°C | 1.387 | 1.400 | 1.413 | |
| | | To GAT pull up, –40 to 85°C | 1.384 | 1.400 | 1.419 | |
| I_{HYSUV} | UV hysteresis | UV = –45.5 V | –11 | –10 | –9 | μA |
| I_{ILUV} | UV low-level input current | UV = –47 V | –1 | | 1 | μA |
| V_{THOV} | OV threshold voltage, OV rising, to –VINA | To GAT pull up | 1.376 | 1.400 | 1.426 | V |
| I_{HYSOV} | OV hysteresis | OV = –45.5 V | –11.1 | –10 | –8.6 | μA |
| I_{ILOV} | OV low-level input current | OV = –47 V | –1 | | 1 | μA |
| Linear Current Amplifier (LCA) | | | | | | |
| V_{OH} | High level output, GAT–SOURCE | SENSE = SOURCE | 11 | 14 | 17 | V |
| I_{SINK_f} | GAT sink current in fault | SENSE – SOURCE = 80 mV, GAT = –43 V, FLTIME = 5 V | 30 | 75 | | mA |
| I_{SINK_l} | GAT sink current in linear mode | SENSE – SOURCE = 80 mV, GAT = –43 V, FLTIME = 2 V | | 5 | 10 | |
| I_{IN} | SENSE input current | $0.0\text{ V} < \text{SENSE} - \text{SOURCE} < 0.2\text{ V}$ | –1 | | 1 | μA |
| V_{REF_K} | Reference clamp voltage, SENSE – SOURCE | RAMP – SOURCE = 6 V | 34 | 42 | 50 | mV |
| V_{IO} | Input offset voltage, SENSE – SOURCE | RAMP – SOURCE = 0 V | –7 | | 9 | |
| Ramp Generator | | | | | | |
| I_{SRC1} | RAMP source current, slow turn-on rate | RAMP – SOURCE = 0.25 V | –800 | –550 | –300 | nA |
| I_{SRC2} | RAMP source current, normal rate | RAMP – SOURCE = 1 V and 3 V | –11.3 | –10 | –8.5 | μA |
| V_{OL} | Low-level output voltage | UV = SOURCE | | | 5 | mV |
| A_V | Voltage gain, relative to SENSE | $0\text{ V} < \text{RAMP} - \text{SOURCE} < 5\text{ V}$ | 9.5 | 10 | 10.7 | mV/V |

(1) All voltages are with respect to RTN unless otherwise stated.

(2) Currents are positive into and negative out of the specified terminal.

ELECTRICAL CHARACTERISTICS (continued)

–VINA = –48 V, –VINB = 0 V, UV = 2.5 V, OV = 0.5 V, SENSE = 0 V, RAMP = 0 V, SOURCE = more negative of –VINA and –VINB, all outputs unloaded, T_A = –40°C to 85°C (unless otherwise noted)⁽¹⁾⁽²⁾

| PARAMETER | | TEST CONDITIONS | MIN | TYP | MAX | UNIT |
|--------------------------------|---|--|--------|--------|--------|------|
| Overload Comparator | | | | | | |
| V _{TH_OL} | SENSE current overload threshold | | 100 | 120 | 140 | mV |
| t _{RSP} | Response time | SENSE – SOURCE = 200 mV | 2 | 4 | 7 | µs |
| Fault Timer | | | | | | |
| V _{OL} | FLTTIM low-level output voltage, to –VINA | UV = –48 V | | | 5 | mV |
| I _{CHG} | FLTTIM charging current, current limit mode | FLTTIM – SOURCE = 2 V | –54 | –50 | –41 | µA |
| V _{FLT} | FLTTIM fault threshold voltage to SOURCE | | 3.75 | 4.00 | 4.25 | V |
| V _{RST} | Fault reset threshold to SOURCE | | | 0.5 | | |
| I _{DSG} | FLTTIM Discharge current, retry mode | FLTTIM – SOURCE = 2 V | | 0.38 | 0.75 | µA |
| D | Output duty cycle during retry cycles | SENSE – SOURCE = 80 mV, FLTTIM – SOURCE = 2 V | | 1% | 1.5% | |
| I _{RST} | FLTTIM discharge current, timer reset mode | FLTTIM – SOURCE = 2 V, SENSE = 2 V | | 1 | | mA |
| Logic Outputs (FLT, PG) | | | | | | |
| I _{OFLT} | FLT high-level output leakage current | UV = –48 V, FLT – SOURCE = 80 V | –10 | | 10 | µA |
| I _{OHPG} | PG high-level output leakage current | UV = –45 V, PG – SOURCE = 80 V | –10 | | 10 | |
| R _{DS(on)} | FLT ON resistance | SENSE – SOURCE = 80 mV, FLTTIM – SOURCE = 5 V, I(FLT) = 1 mA | | 50 | 80 | Ω |
| R _{DS(on)} | PG ON resistance | UV = –48 V, I _O (PG) = 1 mA | | 50 | 80 | |
| Supply Selector | | | | | | |
| V _{THA} | Threshold voltage, –VINA falling | –VINB = –48 V, –VINA falling | –48.45 | –48.40 | –48.35 | V |
| V _{THB} | Threshold voltage, –VINB falling | –VINA = –48 V, –VINB falling | –48.45 | –48.40 | –48.35 | |
| I _{SINK} | GATA sink current | –VINA = 0 V, –VINB = –48 V, GATA = –41 V | 30 | 80 | | mA |
| I _{SOURCE} | GATA source current | –VINA = –48 V, –VINB = –0 V, GATA = –41 V | | –50 | –20 | µA |
| I _{SINK} | GATB sink current | –VINA = –48 V, –VINB = –0 V, GATB = –41 V | 30 | 80 | | mA |
| I _{SOURCE} | GATB source current | –VINA = 0 V, –VINB = –48 V, GATB = –41 V | | –50 | –20 | µA |
| V _{OLA} | GATA low voltage to –VINA | VINA = 0 V, –VINB = –48 V | | | 0.1 | V |
| V _{OLA} | GATA high voltage to –VINA | –VINA = –48 V, –VINB = 0 V | 11 | 14 | 17 | |
| V _{OLB} | GATB low voltage to –VINB | –VINA = –48 V, –VINB = 0 V | | | 0.1 | |
| V _{OLB} | GATB high voltage to –VINB | –VINA = 0 V, –VINB = –48 V | 11 | 14 | 17 | |

PIN FUNCTIONS

| PIN | | I/O | DESCRIPTION |
|-------------------------|-----|-----|--|
| NAME | NO. | | |
| $\overline{\text{FLT}}$ | 2 | O | Open-drain, active-low indication that the part is in fault. |
| FLTTIM | 5 | I/O | Connection for user programming of the fault timeout period. |
| GAT | 11 | O | Gate drive for external N-channel FET that ramps load current and disconnects in the event of a fault. |
| GATA | 9 | O | Gate drive for external N-channel FET that selects –VINA. |
| GATB | 8 | O | Gate drive for external N-channel FET that selects –VINB. |
| OV | 4 | I | Over voltage sense input. |
| PG | 12 | O | Open-drain, active-high indication that the power FET is fully enhanced. |
| RAMP | 6 | I/O | Programming input for setting the inrush current slew rate. |
| RTN | 1 | I | Supply return (ground). |
| SENSE | 10 | I | Positive current sense input. |
| SOURCE | 7 | I/O | Negative current sense input. |
| UV | 3 | I | Under voltage sense input. |
| –VINA | 14 | I | Negative supply input A. |
| –VINB | 13 | I | Negative supply input B. |

PIN DESCRIPTIONS

$\overline{\text{FLT}}$: Open-drain, active-low indication that TPS2350 has shut down due to a faulted load. This happens if the load current stays limited by the linear current amplifier for more than the fault time (time to charge the FLTTIM capacitor). $\overline{\text{FLT}}$ is cleared when both supplies drop below the UV-comparator threshold or one supply exceeds the OV-comparator threshold. The $\overline{\text{FLT}}$ output is pulled to the lower of –VINA and –VINB. The $\overline{\text{FLT}}$ output is able to sink 10 mA when in fault, withstand 80 V without leakage when not faulted, and withstand transients as high as 100 V when limited by a series resistor of at least 10 k Ω .

FLTTIM: Connection for user programming of the fault timeout period. An external capacitor connected from FLTTIM to SOURCE establishes the timeout period to declare a fault condition. This timeout protects against indefinite current sourcing into a faulted load, and also provides a filter against nuisance trips from momentary current spikes or surges. TPS2350 define a fault condition as voltage at the SENSE pin at or greater than the 42-mV fault threshold. When a fault condition exists, the timer is active. The devices manage fault timing by charging the external capacitor to the 4-V fault threshold, then subsequently discharging it at approximately 1% the charge rate to establish the duty cycle for retrying the load. Whenever the fault latch is set (timer expired), GAT and $\overline{\text{FLT}}$ are pulled low.

GAT: Gate drive for an external N-channel protection power MOSFET. When either input supply is above the UV threshold and both are below the OV threshold, gate drive is enabled and the device begins charging the external capacitor connected to RAMP. RAMP develops the reference voltage at the non-inverting input of the internal LCA. The inverting input is connected to the current sense node, SENSE. The LCA acts to slew the pass FET gate to force the SENSE voltage to track the reference. The reference is internally clamped to 42 mV, so the maximum current that can be sourced to the load is determined by the sense resistor value as $I_{\text{MAX}} \leq 42 \text{ mV}/R_{\text{SENSE}}$. Once the load voltage has ramped up to the input dc potential and current demand drops off, the LCA drives GAT 14 V above SOURCE to fully enhance the pass FET, completing the low-impedance supply return path for the load.

GATA: Gate drive for an external N-channel power MOSFET to select –VINA. When –VINA is more negative than –VINB, GATA is pulled 14 V above –VINA, turning on the –VINA power FET. When –VINB is more negative than –VINA, GATA is pulled down to –VINB, turning off the –VINA power FET.

GATB: Gate drive for an external N-channel power MOSFET to select –VINB. When –VINB is more negative than –VINA, GATB is pulled 14 V above –VINB, turning on the –VINB power FET. When –VINA is more negative than –VINB, GATB is pulled down to –VINA, turning off the –VINB power FET.

PG: Open-drain, active-high indication that load current is below the commanded current and the power FET is fully enhanced. When commanded load current is more than the actual load current, the linear current amplifier (LCA) will raise the power MOSFET gate voltage to fully enhance the power MOSFET. At this time, the PG output will go high. This output can be used to enable a down-stream dc-to-dc converter. The PG output is pulled to the lower of –VINA and –VINB. The PG output is able to sink 10 mA when in fault, withstand 80 V without leakage when power is not good, and withstand transients as high as 100 V when limited by a series resistor of at least 10 k Ω .

OV: Over voltage comparator input. This input is typically connected to a voltage divider between RTN and SOURCE to sense the magnitude of the more negative input supply. If OV is less than 1.4 V above SOURCE, UV is more than 1.4 V above SOURCE, and there is no fault, the linear current amp will be enabled. In the event of a fault, pulling OV high or UV low will reset the fault latch and allow restarting. OV can also be used as an active-low logic enable input. The over-voltage comparator hysteresis is programmed by the equivalent resistance seen looking into the divider at the OV input.

RAMP: Programming input for setting inrush current and current slew rate. An external capacitor connected between RAMP and SOURCE establishes turn-on current slew rate. During turn-on, TPS2350 charges this capacitor to establish the reference input to the LCA at 1% of the voltage from RAMP to SOURCE. The closed-loop control of the LCA and the pass FET maintains the current-sense voltage from SENSE to SOURCE at the reference potential, so the load current slew rate is directly set by the voltage ramp rate at the RAMP pin. When fully charged, RAMP can exceed SOURCE by 6 V, but the reference is internally clamped to 42 mV, limiting load current to 42 mV/R_{SENSE}. When the output is disabled via OV, UV, or due to a load fault, the RAMP capacitor is discharged and held low to initialize for the next turn on.

RTN: Positive supply input. For negative voltage systems, this pin connects directly to the return node of the input power bus.

SENSE: Current sense input. An external low-value resistor connected between SENSE and SOURCE is used to monitor current magnitude. There are two internal device thresholds associated with the voltage at the SENSE pin. During ramp-up of the load capacitance or during other periods of excessive demand, the linear current amp (LCA) will regulate this voltage to 42 mV. Whenever the LCA is in current regulation mode, the capacitor at FLTTIM is charging and the timer is running. If the LCA is saturated, GAT is pulled 14 V above SOURCE. At this time, a fast fault such as a short circuit can cause the SENSE voltage to rapidly exceed 120 mV (the overload threshold). In this case, the GAT pin is pulled low rapidly, bypassing the fault timer.

SOURCE: Connection to the sources of the input supply negative rail selector FETs and the negative terminal of the current sense resistor. The supply select comparator will turn on the appropriate power FET to connect SOURCE to the more negative of –VINA and –VINB.

UV: Under voltage comparator input. This input is typically connected to a voltage divider between RTN and SOURCE to sense the magnitude of the more negative input supply. If UV is more than 1.4 V above SOURCE, OV is less than 1.4 V above SOURCE, and there is no fault, the linear current amp will be enabled. In the event of a fault, pulling UV low or OV high will reset the fault latch and allow restarting. UV can also be used as an active high logic enable input. The under-voltage comparator hysteresis is programmed by the equivalent resistance seen looking into the divider at the UV input.

–VINA: Negative supply input A. This pin connects directly to the first input supply negative rail.

–VINB: Negative supply input B. This pin connects directly to the second input supply negative rail.

TYPICAL CHARACTERISTICS

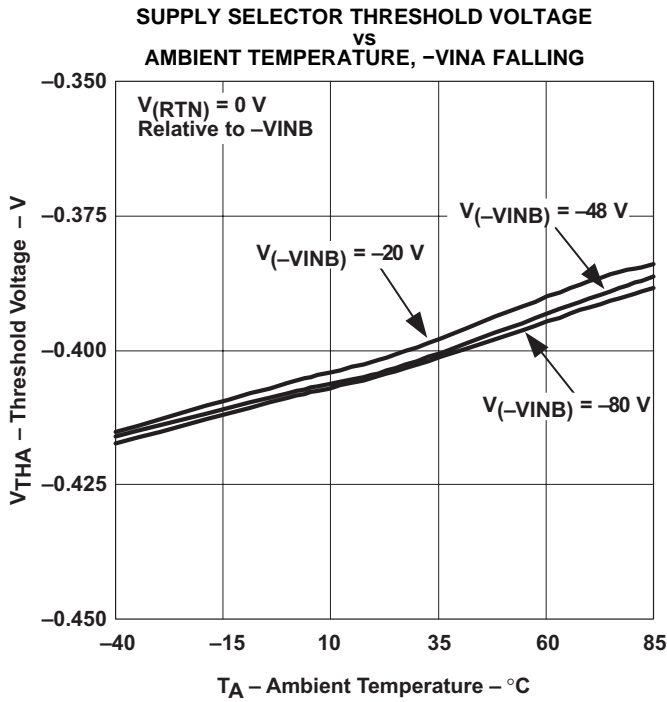

Figure 1.

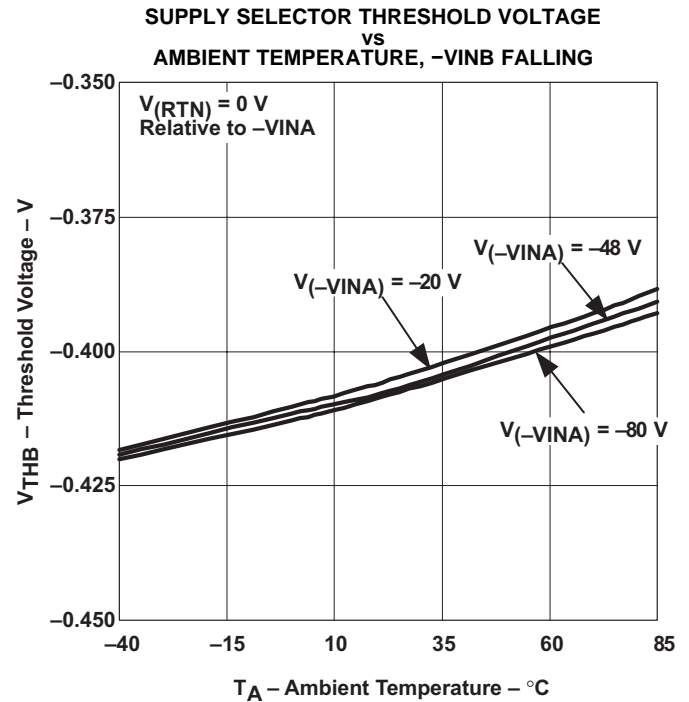

Figure 2.

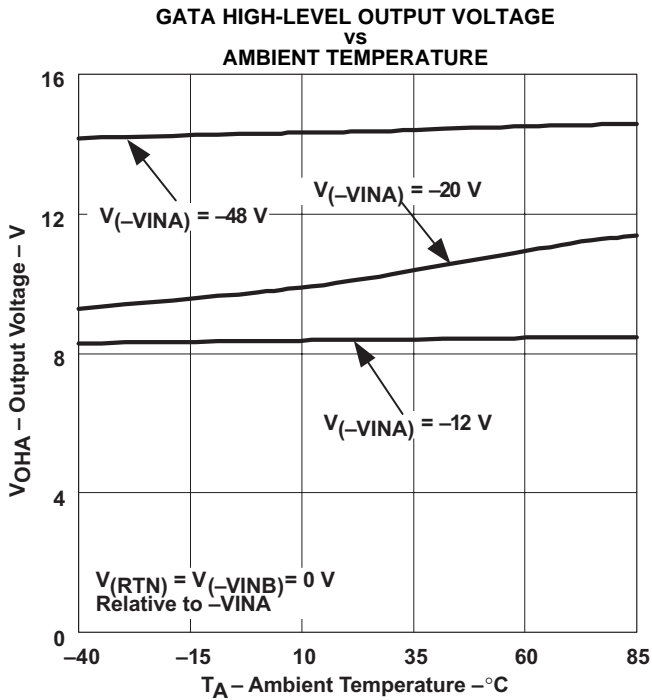

Figure 3.

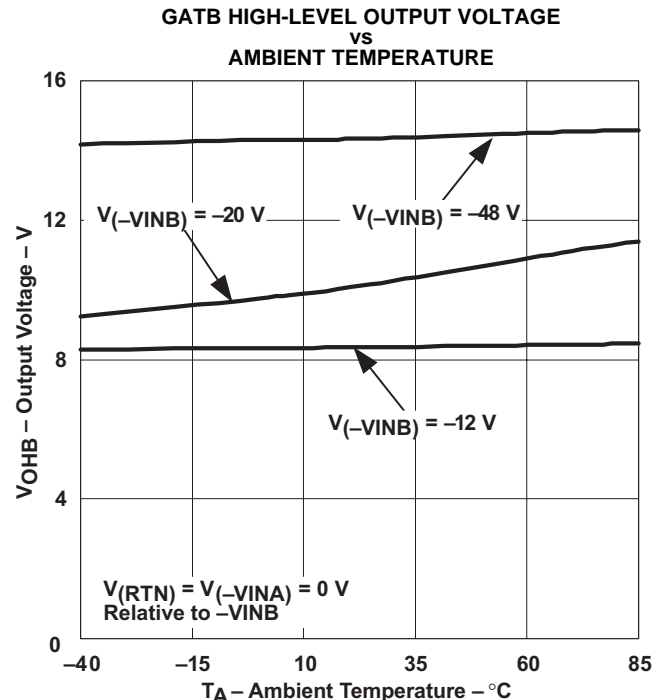
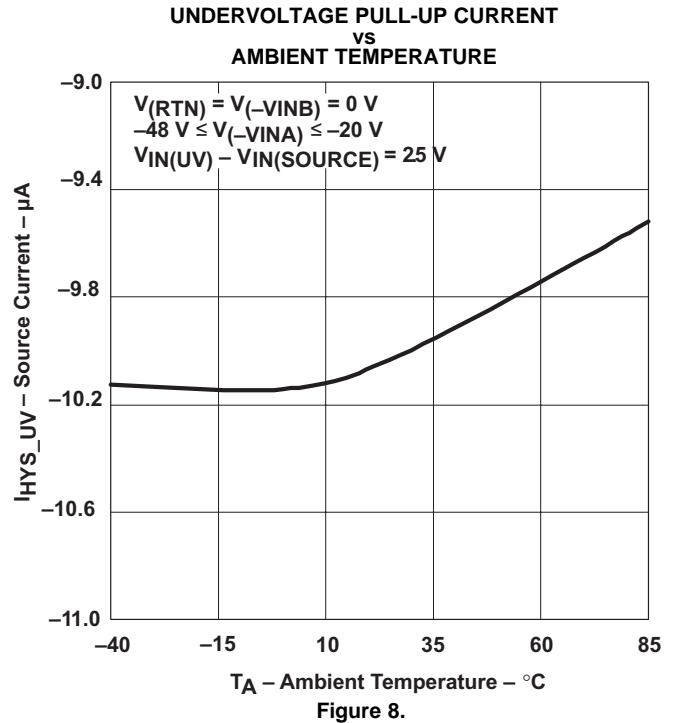
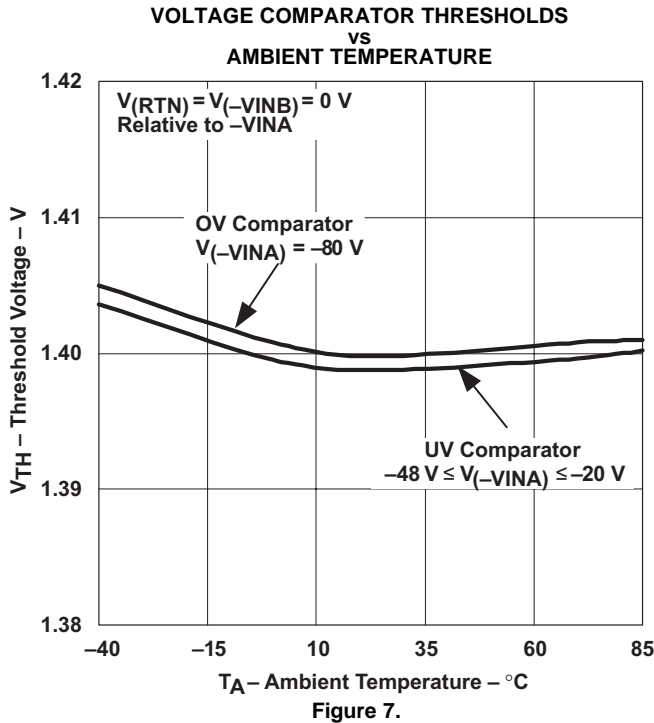
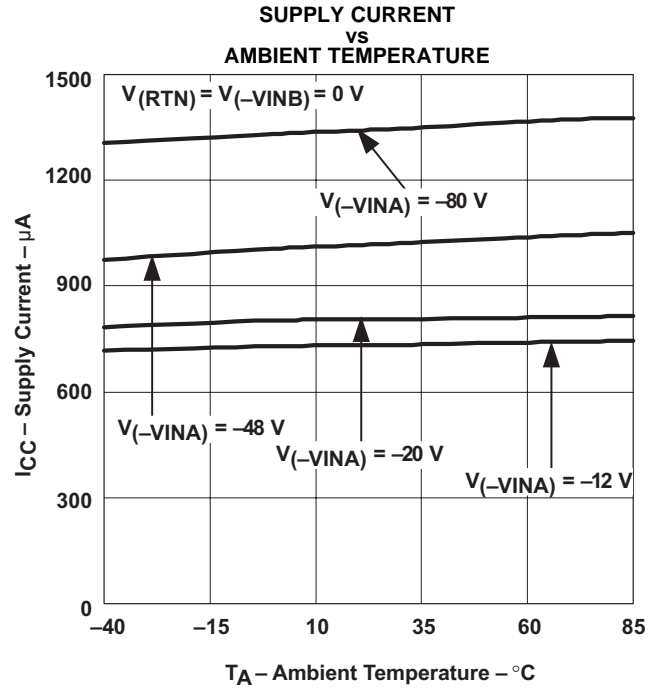
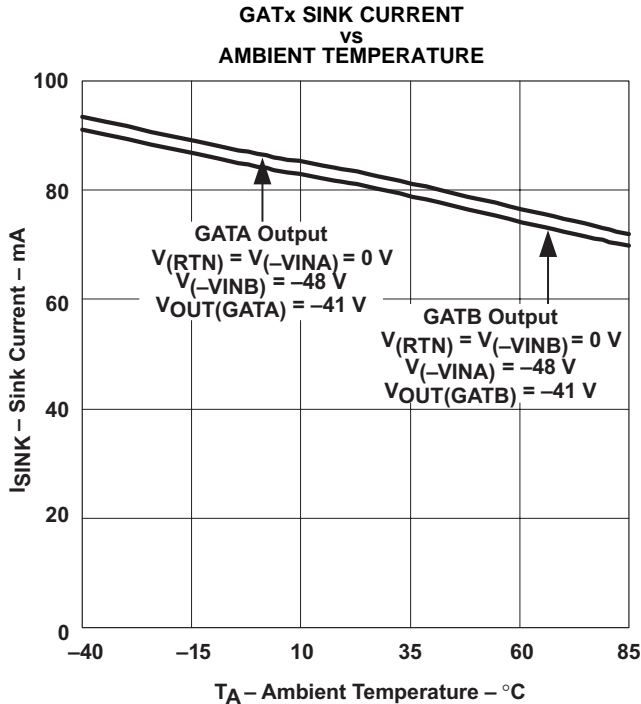
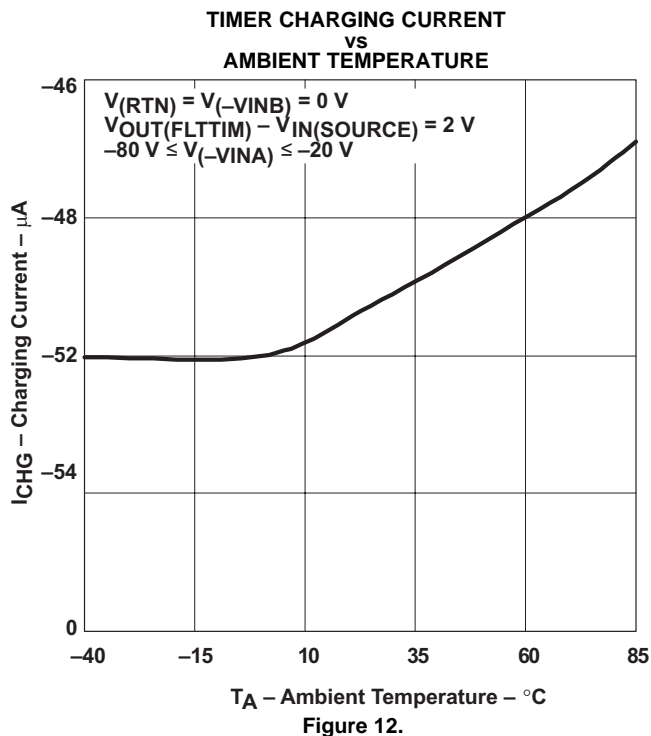
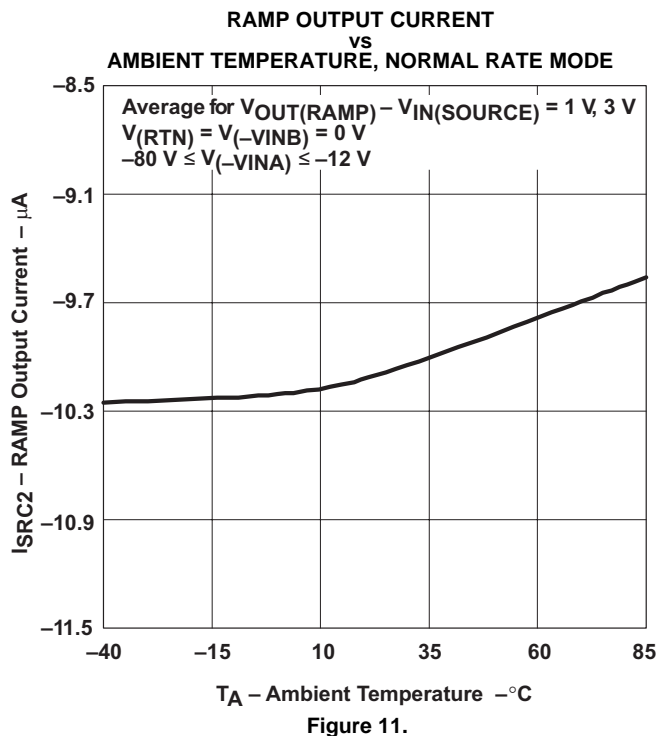
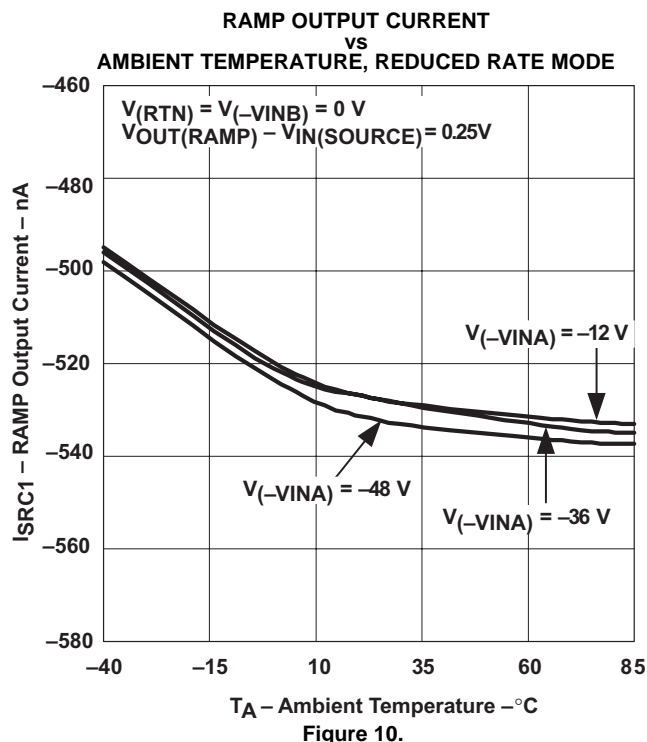
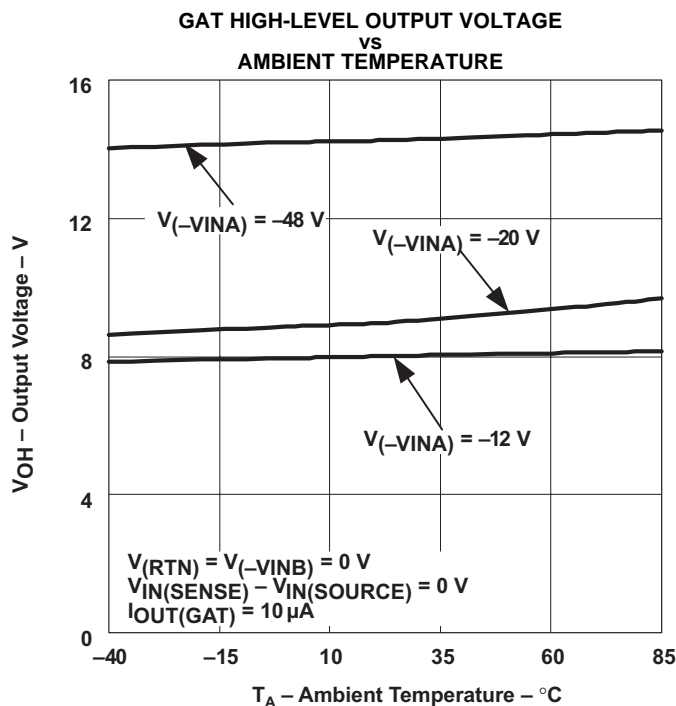

Figure 4.

TYPICAL CHARACTERISTICS



TYPICAL CHARACTERISTICS



TYPICAL CHARACTERISTICS

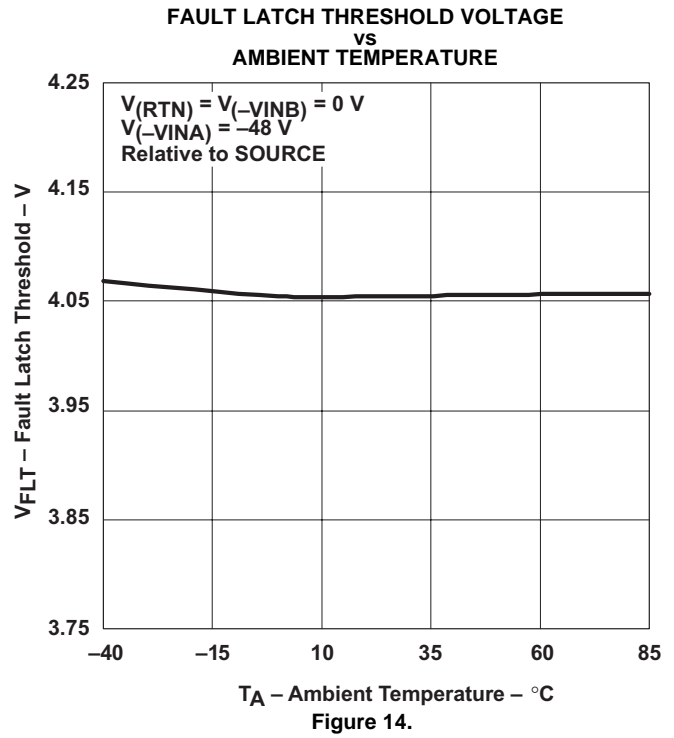
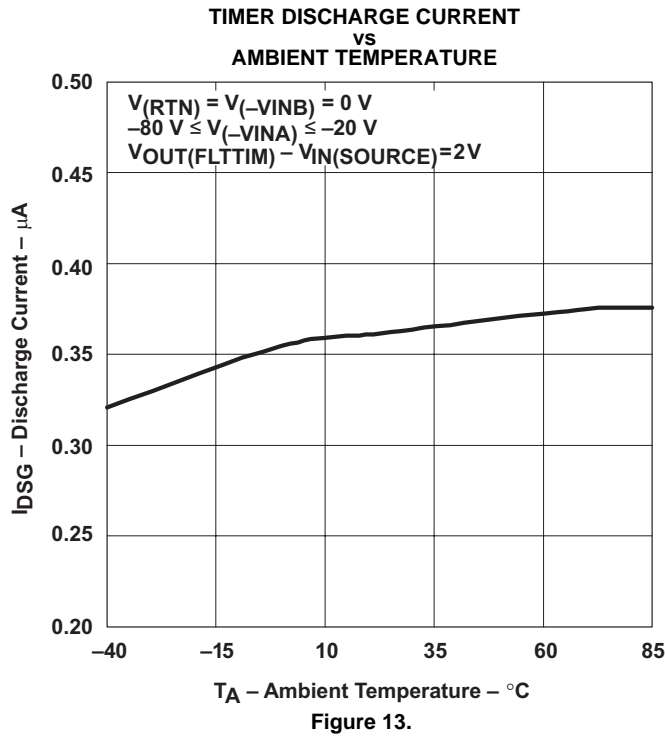

FUNCTIONAL BLOCK DIAGRAM

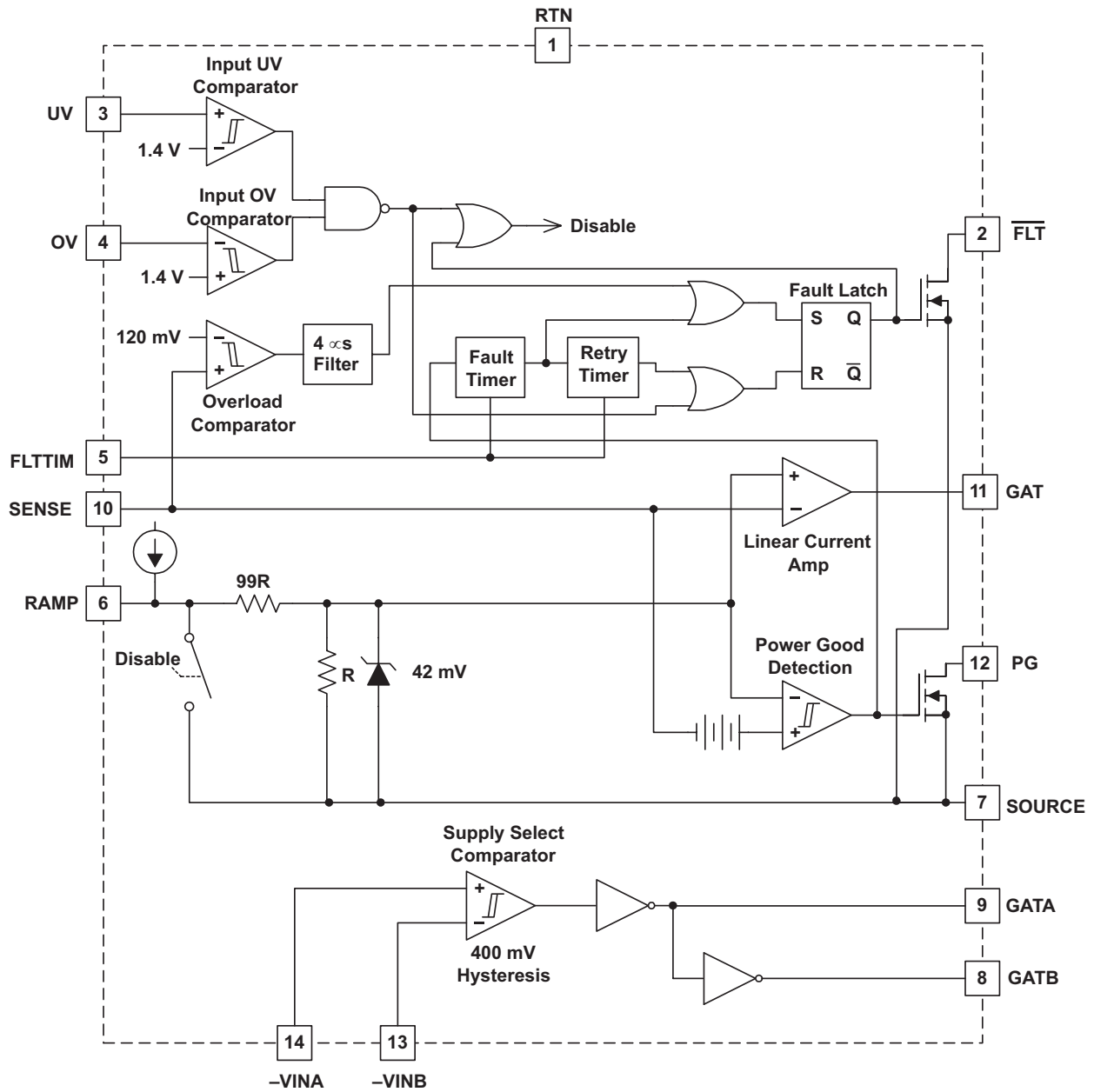

APPLICATION INFORMATION

Supply Section

The supply selection comparator selects between $-V_{INA}$ and $-V_{INB}$ based on which supply has a larger magnitude. To prevent chattering between two nearly identical supplies, the supply selection comparator has 400 mV of hysteresis. This prevents supply noise or ripple from tripping the comparator and should be adequate for most systems. Hysteresis is set to 400 mV to give the highest noise margin without allowing conduction in the body diodes of the supply selection FETs.

For systems with many cards, high current cards, or long cables between the power and the load, the voltage loss in the cable can be significant. If the supplies are close to the same magnitude, then the voltage loss in the cable could cause enough drop to exceed the supply selection comparator hysteresis. In this case, the supply selection comparator hysteresis must be increased.

TPS2350 allows you to increase the hysteresis of the supply selection comparator with external resistors, limited to the threshold of the external FETs. Figure 15 shows a system with higher hysteresis, set by R4, R5, R6 and R7. The resistors act as a simple multiplier to increase the voltage differential required to switch the comparator. For example, for $R4 = R5 = 40\text{ k}\Omega$, and $R6 = R7 = 20\text{ k}\Omega$, the hysteresis is approximately 1.2 V. Because of the large hysteresis, the supply selection power FETs are replaced with dual power FETs, configured so that the body diodes can never conduct. The GATA and GATB outputs are able to switch dual FETs, so no additional drive or logic circuits are required.

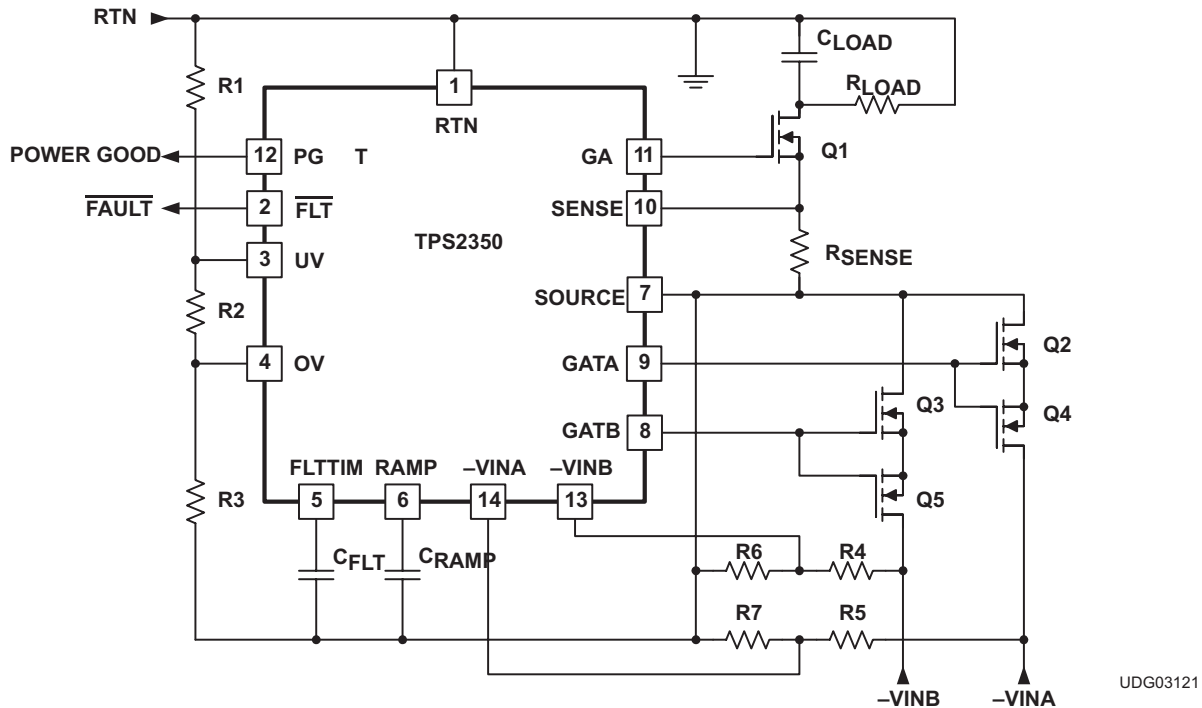

Figure 15. Typical Application to Develop Higher Supply Comparator Hysteresis

APPLICATION INFORMATION

Setting the Sense Resistor Value

Due to the current-limiting action of the internal LCA, the maximum allowable load current for an implementation is easily programmed by selecting the appropriate sense resistor value. The LCA acts to limit the sense voltage V_{SENSE} to its internal reference. Once the voltage at the RAMP pin exceeds approximately 4 V, this limit is the clamp voltage, V_{REF_K} . Therefore, a maximum sense resistor value can be determined from [Equation 1](#).

$$R_{SENSE} \leq \frac{34\text{mV}}{I_{MAX}} \quad (1)$$

where

- R_{SENSE} is the resistor value
- I_{MAX} is the desired current limit

When setting the sense resistor value, it is important to consider two factors, the minimum current that may be imposed by the TPS2350, and the maximum load under normal operation of the module. For the first factor, the specification minimum clamp value is used, as seen in [Equation 1](#). This method accounts for the tolerance in the sourced current limit below the typical level expected (42 mV/ R_{SENSE}). (The clamp measurement includes LCA input offset voltage; therefore, this offset does not have to be factored into the current limit again.) Second, if the load current varies over a range of values under normal operating conditions, then the maximum load level must be allowed for by the value of R_{SENSE} . One example of this is when the load is a switching converter, or brick, which draws higher input current, for a given power output, when the distribution bus is at the low end of its voltage range, with decreasing draw at higher supply voltages. To avoid current limit operation under normal loading, some margin should be designed in between this maximum anticipated load and the minimum current limit level, or $I_{MAX} > I_{LOAD(max)}$, for [Equation 1](#).

For example, using a 10-m Ω sense resistor for a nominal 2-A load application provides a minimum of 1.4 A of overhead for load variance/margin. Typical bulk capacitor charging current during turn-on is 4.2 A (42 mV/10 m Ω).

Setting the Inrush Slew Rate

The TPS2350 device enables user-programming of the maximum current slew rate during load start-up events. A capacitor tied to the RAMP pin (C_{RAMP} in the typical application diagram) controls the di/dt rate. Once the sense resistor value has been established, a value for C_{RAMP} , in microfarads, can be determined from [Equation 2](#).

$$C_{RAMP} = \frac{11.3}{100 \times R_{SENSE} \times \left(\frac{di}{dt}\right)_{(max)}} \quad (2)$$

where

- R_{SENSE} is the sense resistor value in Ω
- $(di/dt)_{(max)}$ is the desired maximum slew rate in A/s

For example, if the desired slew rate for the typical application shown is 1500 mA/ms, the calculated value for C_{RAMP} is about 7500 pF. Selecting the next larger standard value of 8200 pF provides some margin for capacitor and sense resistor tolerances.

The TPS2350 initiates ramp capacitor charging, and consequently load current slewing, at a reduced rate. This reduced rate applies until the voltage on the RAMP pin is about 0.5 V. The maximum di/dt rate, as set by [Equation 2](#), is effective once the device switches to a 10- μ A charging source.

APPLICATION INFORMATION

Setting the Fault Timing Capacitor

The fault timeout period is established by the value of the capacitor connected to the FLTTIM pin, C_{FLT} . The timeout period permits riding out spurious current glitches and surges that may occur during operation of the system, and prevents indefinite sourcing into faulted loads. However, to ensure smooth voltage ramping under all conditions of load capacitance and input supply potential, the minimum timeout should be set to accommodate these system variables. To do this, a rough estimate of the maximum voltage ramp time for a completely discharged plug-in card provides a good basis for setting the minimum timer delay. This section presents a quick procedure for calculating the timing capacitance requirement. However, for proper operation of the TPS2350, there is an absolute minimum value of 0.01- μF for C_{FLT} . This minimum requirement overrides any smaller results of [Equation 7](#) and [Equation 8](#).

Due to the three-phase nature of the load current at turn-on, the load voltage ramp has potentially three distinct phases. This profile depends on the relative values of load capacitance, input DC potential, maximum current limit and other factors. The first two phases are characterized by the two different slopes of the current ramp; the third phase, if required to complete load charging, is the constant-current charging at I_{MAX} . Considering the two current ramp phases to be one period at an average di/dt simplifies calculation of the required timing capacitor.

For the TPS2350, the typical duration of the soft-start period, t_{SS} , is given by [Equation 3](#).

$$t_{SS} = 1260 \times C_{RAMP} \quad (3)$$

where

- t_{SS} is the soft-start period in ms
- C_{RAMP} is given in μF

During this current ramp period, the load voltage magnitude which is attained is estimated by [Equation 4](#).

$$V_{LSS} = \frac{I_{AVG}}{2 \times C_{LOAD} \times C_{RAMP} \times 100 \times R_{SENSE}} \times (t_{SS})^2 \quad (4)$$

where

- V_{LSS} is the load voltage reached during soft-start
- I_{AVG} is 3.18 μA for the TPS2350
- C_{LOAD} is the load capacitance in Farads
- t_{SS} is the soft-start period in s

The quantity I_{AVG} in [Equation 4](#) is a weighted average of the two charge currents applied to C_{RAMP} during turn-on, considering the typical output values.

APPLICATION INFORMATION

If the result of [Equation 4](#) is larger than the maximum input supply value, then the load can be expected to charge completely during the inrush slewing portion of the insertion event. However, if this voltage is less than the maximum supply input, $V_{IN(MAX)}$, the HSPM transitions to the constant-current charging of the load. The remaining amount of time required at IMAX is determined from [Equation 5](#).

$$t_{CC} = \frac{C_{LOAD} \times (V_{IN(MAX)} - V_{LSS})}{\frac{V_{REF_K(MIN)}}{R_{SENSE}}} \quad (5)$$

where

- t_{CC} is the constant-current voltage ramp time, in seconds
- $V_{REF_K(MIN)}$ is the minimum clamp voltage, 34 mV

With this information, the minimum recommended value timing capacitor C_{FLT} can be determined. The delay time needed will be either a time t_{SS2} or the sum of t_{SS2} and t_{CC} , according to the estimated time to charge the load. The quantity t_{SS2} is the duration of the normal rate current ramp period, and is given by [Equation 6](#).

$$t_{SS2} = 0.35 \times C_{RAMP} \quad (6)$$

where

- C_{RAMP} is given in μF

Since fault timing is generated by the constant-current charging of C_{FLT} , the capacitor value is determined from either [Equation 7](#) or [Equation 8](#), as appropriate.

$$C_{FLT(MIN)} = \frac{54 \times t_{SS2}}{3.75} \quad (7)$$

$$C_{FLT(MIN)} = \frac{54 \times (t_{SS2} + t_{CC})}{3.75} \quad (8)$$

where

- $C_{FLT(MIN)}$ is the recommended capacitor value, in μ -Farads
- t_{SS2} is the result of [Equation 6](#), in seconds
- t_{CC} is the result of [Equation 5](#), in seconds

Continuing this calculation example, using a 220- μF input capacitor (C_{LOAD}), [Equation 3](#) and [Equation 4](#) estimate the load voltage ramping to approximately $-45 V$ during the soft-start period. If the module should operate down to $-72-V$ input supply, approximately another 1.4 ms of constant-current charging may be required. Therefore, [Equation 6](#) and [Equation 8](#) are used to determine $C_{FLT(MIN)}$, and the result is approximately 0.039- μF .

APPLICATION INFORMATION

Setting the Undervoltage and Overvoltage Thresholds

The UV and OV pins can be used to set the undervoltage (V_{UV}) and overvoltage (V_{OV}) thresholds of the hot swap circuit. When the input supply is below V_{UV} or above V_{OV} , the GAT pin is held low, disconnecting power from the load, and the PG output is deasserted. When input voltage is within the UV/OV window, the GAT pin drive is enabled, assuming all other input conditions are valid for turn-on.

Threshold hysteresis is provided via two internal sources which are switched to either pin whenever the corresponding input level exceeds the internal 1.4-V reference. The additional bias shifts the pin voltage in proportion to the external resistance connected to it. This small voltage shift at the device pin is gained up by the external divider to input supply levels.

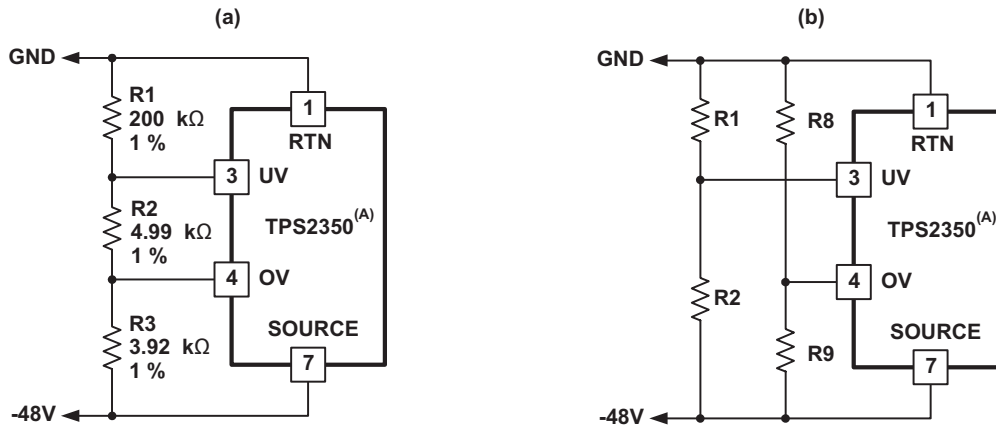

$$V_{UV_L} = \frac{R1 + R2 + R3}{R2} \times V_{THUV}$$

$$V_{OV_L} = \frac{R1 + R2 + R3}{R3} \times V_{THOV} - I_{HYSUV} \times R1$$

$$V_{UV_L} = \frac{R1 + R2}{R2} \times V_{THUV}$$

$$V_{OV_L} = \frac{R8 + R9}{R9} \times V_{THOV}$$

UDG0312 1

A. Additional details omitted for clarity

Figure 16. Programming the Undervoltage and Overvoltage Thresholds

The UV and OV thresholds can be individually programmed with a three-resistor divider connected to the TPS2350 as shown in the typical application diagram, and again in Figure 16a. When the desired trip voltages and undervoltage hysteresis have been established for the protected board, the resistor values needed can be determined from the following equations. Generally, the process is simplest by first selecting the top leg of the divider (R1 in the diagram) needed to obtain the threshold hysteresis. This value is calculated from [Equation 9](#).

$$R1 = \frac{V_{HYS_UV}}{10\mu A} \quad (9)$$

where

- V_{HYS_UV} is the undervoltage hysteresis value

APPLICATION INFORMATION

For example, assume the typical application design targets have been set to undervoltage turn-on at 33 V (input supply rising), turn-off at 31 V (input voltage falling), and overvoltage shutdown at 72 V. Then [Equation 9](#) yields $R1 = 200 \text{ k}\Omega$ for the 2-V hysteresis. Once the value of $R1$ is selected, it is used to calculate resistors $R2$ and $R3$.

$$R2 = \frac{1.4 \times R1}{(V_{UV_L} - 1.4)} \times \left[1 - \frac{V_{UV_L}}{(V_{OV_L} + 10^{-5} \times R1)} \right] \quad (10)$$

$$R3 = \frac{1.4 \times R1 \times V_{UV_L}}{(V_{UV_L} - 1.4) \times (V_{OV_L} + 10^{-5} \times R1)} \quad (11)$$

where

- V_{UV_L} is the UVLO threshold when the input supply is low; i.e., less than V_{UV} , and
- V_{OV_L} is the OVLO threshold when the input supply is low; i.e., less than V_{OV}

Again referring to the Figure 17a schematic, [Equation 10](#) and [Equation 11](#) produce $R2 = 4.909 \text{ k}\Omega$ (4.99 k Ω selected) and $R3 = 3.951 \text{ k}\Omega$ (3.92 k Ω selected), as shown. For the selected values, the expected nominal supply thresholds are $V_{UV_L} = 32.8 \text{ V}$, $V_{UV_H} = 30.8 \text{ V}$, and $V_{OV_L} = 72.6 \text{ V}$. The hysteresis of the overvoltage threshold, as seen at the supply inputs, is given by the quantity $(10 \text{ }\mu\text{A}) \times (R1 + R2)$. For the majority of applications, this value is very nearly the same as the UV hysteresis, since typically $R1 \gg R2$.

If more independent control is needed for the OVLO hysteresis, there are several options. One option is to use separate dividers for both the UV and OV pins, as shown in Figure 16b. In this case, once $R1$ and $R8$ have been selected for the required hysteresis per [Equation 9](#), and values for the bottom resistors in the divider ($R2$ and $R9$ in Figure 16b) can be calculated using [Equation 12](#).

$$R_{XVLO} = \frac{V_{REF}}{(V_{XV_L} - V_{REF})} \times R_{(TOP)} \quad (12)$$

where

- R_{XVLO} is $R2$ or $R9$
- $R_{(TOP)}$ is $R1$ or $R8$ as appropriate for the threshold being set
- V_{XV_L} is the under (V_{UV_L}) or overvoltage (V_{OV_L}) threshold at the supply input, and
- V_{REF} is either V_{THUV} or V_{THOV} from the specification table, as required for the resistor being calculated.

Reverse Voltage Protection

In some applications, it may be necessary to protect the TPS2350 against reverse polarity supply connections or input transients. If the potential at either the $-VINA$ or $-VINB$ pin rises above that of the RTN pin, device damage may result. If the application environment is such that these conditions are anticipated, a small-signal diode should be inserted between the supply return bus and the TPS2350 RTN pin, as shown in the Typical Application diagram. A 75-V to 100-V rated device (VRRM), such as MMBD4148 or BAV19, is recommended.

REVISION HISTORY

Changes from Revision B (December 2005) to Revision C **Page**

- Replaced the Dissipations Rating table with the Thermal Information table [3](#)

Changes from Revision C (March 2011) to Revision D **Page**

- Changed the FUNCTIONAL BLOCK DIAGRAM - Power Good Detection terminals were reversed [11](#)

PACKAGING INFORMATION

| Orderable Device | Status (1) | Package Type | Package Drawing | Pins | Package Qty | Eco Plan (2) | Lead finish/ Ball material (6) | MSL Peak Temp (3) | Op Temp (°C) | Device Marking (4/5) | Samples |
|------------------|---------------|--------------|-----------------|------|-------------|-----------------|--------------------------------------|----------------------|--------------|-------------------------|-------------------------|
| TPS2350D | ACTIVE | SOIC | D | 14 | 50 | RoHS & Green | NIPDAU | Level-1-260C-UNLIM | -40 to 85 | TPS2350 | Samples |
| TPS2350DR | ACTIVE | SOIC | D | 14 | 2500 | RoHS & Green | NIPDAU | Level-1-260C-UNLIM | -40 to 85 | TPS2350 | Samples |
| TPS2350PW | ACTIVE | TSSOP | PW | 14 | 90 | RoHS & Green | NIPDAU | Level-1-260C-UNLIM | -40 to 85 | TPS2350 | Samples |
| TPS2350PWG4 | ACTIVE | TSSOP | PW | 14 | 90 | RoHS & Green | NIPDAU | Level-1-260C-UNLIM | -40 to 85 | TPS2350 | Samples |
| TPS2350PWR | ACTIVE | TSSOP | PW | 14 | 2000 | RoHS & Green | NIPDAU | Level-1-260C-UNLIM | -40 to 85 | TPS2350 | Samples |

(1) The marketing status values are defined as follows:

ACTIVE: Product device recommended for new designs.

LIFEBUY: TI has announced that the device will be discontinued, and a lifetime-buy period is in effect.

NRND: Not recommended for new designs. Device is in production to support existing customers, but TI does not recommend using this part in a new design.

PREVIEW: Device has been announced but is not in production. Samples may or may not be available.

OBSELETE: TI has discontinued the production of the device.

(2) **RoHS:** TI defines "RoHS" to mean semiconductor products that are compliant with the current EU RoHS requirements for all 10 RoHS substances, including the requirement that RoHS substance do not exceed 0.1% by weight in homogeneous materials. Where designed to be soldered at high temperatures, "RoHS" products are suitable for use in specified lead-free processes. TI may reference these types of products as "Pb-Free".

RoHS Exempt: TI defines "RoHS Exempt" to mean products that contain lead but are compliant with EU RoHS pursuant to a specific EU RoHS exemption.

Green: TI defines "Green" to mean the content of Chlorine (Cl) and Bromine (Br) based flame retardants meet JS709B low halogen requirements of <=1000ppm threshold. Antimony trioxide based flame retardants must also meet the <=1000ppm threshold requirement.

(3) MSL, Peak Temp. - The Moisture Sensitivity Level rating according to the JEDEC industry standard classifications, and peak solder temperature.

(4) There may be additional marking, which relates to the logo, the lot trace code information, or the environmental category on the device.

(5) Multiple Device Markings will be inside parentheses. Only one Device Marking contained in parentheses and separated by a "~" will appear on a device. If a line is indented then it is a continuation of the previous line and the two combined represent the entire Device Marking for that device.

(6) Lead finish/Ball material - Orderable Devices may have multiple material finish options. Finish options are separated by a vertical ruled line. Lead finish/Ball material values may wrap to two lines if the finish value exceeds the maximum column width.

Important Information and Disclaimer: The information provided on this page represents TI's knowledge and belief as of the date that it is provided. TI bases its knowledge and belief on information provided by third parties, and makes no representation or warranty as to the accuracy of such information. Efforts are underway to better integrate information from third parties. TI has taken and continues to take reasonable steps to provide representative and accurate information but may not have conducted destructive testing or chemical analysis on incoming materials and chemicals. TI and TI suppliers consider certain information to be proprietary, and thus CAS numbers and other limited information may not be available for release.

In no event shall TI's liability arising out of such information exceed the total purchase price of the TI part(s) at issue in this document sold by TI to Customer on an annual basis.

TAPE AND REEL INFORMATION

QUADRANT ASSIGNMENTS FOR PIN 1 ORIENTATION IN TAPE



*All dimensions are nominal

| Device | Package Type | Package Drawing | Pins | SPQ | Reel Diameter (mm) | Reel Width W1 (mm) | A0 (mm) | B0 (mm) | K0 (mm) | P1 (mm) | W (mm) | Pin1 Quadrant |
|------------|--------------|-----------------|------|------|--------------------|--------------------|---------|---------|---------|---------|--------|---------------|
| TPS2350DR | SOIC | D | 14 | 2500 | 330.0 | 16.4 | 6.5 | 9.0 | 2.1 | 8.0 | 16.0 | Q1 |
| TPS2350PWR | TSSOP | PW | 14 | 2000 | 330.0 | 12.4 | 6.9 | 5.6 | 1.6 | 8.0 | 12.0 | Q1 |

TAPE AND REEL BOX DIMENSIONS

*All dimensions are nominal

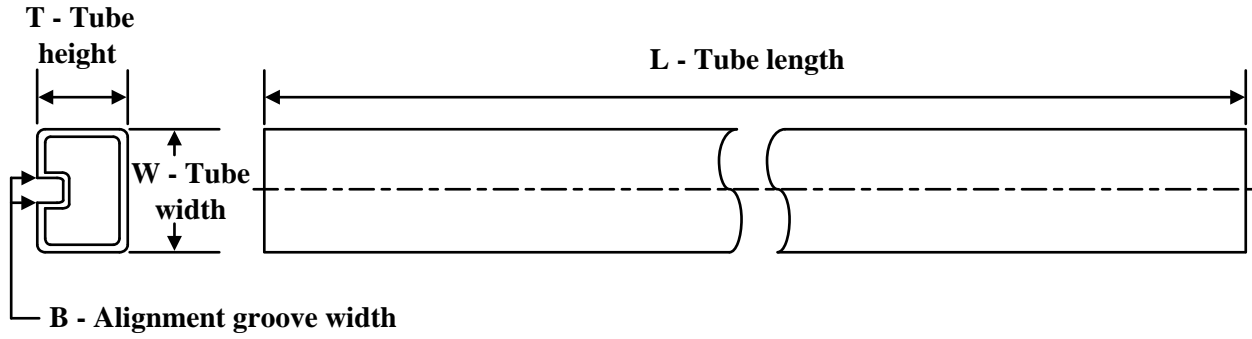
| Device | Package Type | Package Drawing | Pins | SPQ | Length (mm) | Width (mm) | Height (mm) |
|------------|--------------|-----------------|------|------|-------------|------------|-------------|
| TPS2350DR | SOIC | D | 14 | 2500 | 356.0 | 356.0 | 35.0 |
| TPS2350PWR | TSSOP | PW | 14 | 2000 | 356.0 | 356.0 | 35.0 |

TUBE



*All dimensions are nominal

| Device | Package Name | Package Type | Pins | SPQ | L (mm) | W (mm) | T (μm) | B (mm) |
|-------------|--------------|--------------|------|-----|--------|--------|--------|--------|
| TPS2350D | D | SOIC | 14 | 50 | 506.6 | 8 | 3940 | 4.32 |
| TPS2350PW | PW | TSSOP | 14 | 90 | 530 | 10.2 | 3600 | 3.5 |
| TPS2350PWG4 | PW | TSSOP | 14 | 90 | 530 | 10.2 | 3600 | 3.5 |

D (R-PDSO-G14)

PLASTIC SMALL OUTLINE



- NOTES:
- A. All linear dimensions are in inches (millimeters).
 - B. This drawing is subject to change without notice.
 -  Body length does not include mold flash, protrusions, or gate burrs. Mold flash, protrusions, or gate burrs shall not exceed 0.006 (0,15) each side.
 -  Body width does not include interlead flash. Interlead flash shall not exceed 0.017 (0,43) each side.
 - E. Reference JEDEC MS-012 variation AB.

D (R-PDSO-G14)

PLASTIC SMALL OUTLINE



- NOTES:
- All linear dimensions are in millimeters.
 - This drawing is subject to change without notice.
 - Publication IPC-7351 is recommended for alternate designs.
 - Laser cutting apertures with trapezoidal walls and also rounding corners will offer better paste release. Customers should contact their board assembly site for stencil design recommendations. Refer to IPC-7525 for other stencil recommendations.
 - Customers should contact their board fabrication site for solder mask tolerances between and around signal pads.

PW (R-PDSO-G14)

PLASTIC SMALL OUTLINE

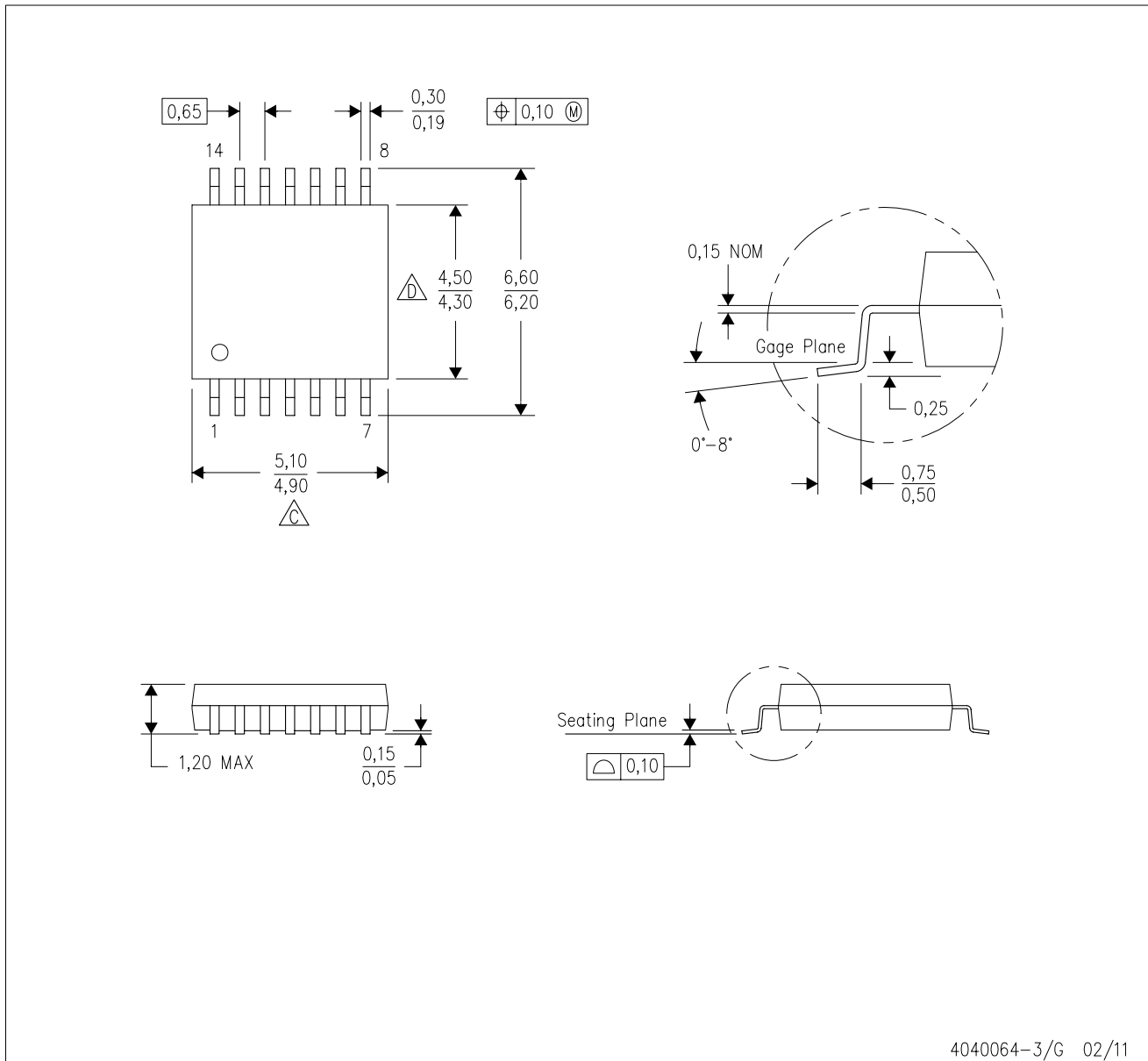

4040064-3/G 02/11

- NOTES:
- A. All linear dimensions are in millimeters. Dimensioning and tolerancing per ASME Y14.5M-1994.
 - B. This drawing is subject to change without notice.
 - C. Body length does not include mold flash, protrusions, or gate burrs. Mold flash, protrusions, or gate burrs shall not exceed 0,15 each side.
 - D. Body width does not include interlead flash. Interlead flash shall not exceed 0,25 each side.
 - E. Falls within JEDEC MO-153

IMPORTANT NOTICE AND DISCLAIMER

TI PROVIDES TECHNICAL AND RELIABILITY DATA (INCLUDING DATA SHEETS), DESIGN RESOURCES (INCLUDING REFERENCE DESIGNS), APPLICATION OR OTHER DESIGN ADVICE, WEB TOOLS, SAFETY INFORMATION, AND OTHER RESOURCES "AS IS" AND WITH ALL FAULTS, AND DISCLAIMS ALL WARRANTIES, EXPRESS AND IMPLIED, INCLUDING WITHOUT LIMITATION ANY IMPLIED WARRANTIES OF MERCHANTABILITY, FITNESS FOR A PARTICULAR PURPOSE OR NON-INFRINGEMENT OF THIRD PARTY INTELLECTUAL PROPERTY RIGHTS.

These resources are intended for skilled developers designing with TI products. You are solely responsible for (1) selecting the appropriate TI products for your application, (2) designing, validating and testing your application, and (3) ensuring your application meets applicable standards, and any other safety, security, regulatory or other requirements.

These resources are subject to change without notice. TI grants you permission to use these resources only for development of an application that uses the TI products described in the resource. Other reproduction and display of these resources is prohibited. No license is granted to any other TI intellectual property right or to any third party intellectual property right. TI disclaims responsibility for, and you will fully indemnify TI and its representatives against, any claims, damages, costs, losses, and liabilities arising out of your use of these resources.

TI's products are provided subject to [TI's Terms of Sale](#) or other applicable terms available either on ti.com or provided in conjunction with such TI products. TI's provision of these resources does not expand or otherwise alter TI's applicable warranties or warranty disclaimers for TI products.

TI objects to and rejects any additional or different terms you may have proposed.

Mailing Address: Texas Instruments, Post Office Box 655303, Dallas, Texas 75265
Copyright © 2022, Texas Instruments Incorporated

Looking for pricing, stock, or lifecycle information?

Click below to explore more details on WIN SOURCE:

 [View TPS2350EVM](#) on WIN SOURCE

 [Texas Instruments](#) Information

Optimize Your Supply Chain with WIN SOURCE Solutions

-  Global Sourcing Solution
-  Obsolete Management
-  Cost Control Management
-  Shortage Management
-  Alternative Solution
-  Excess Inventory Management