



**THE DATASHEET OF  
TPA6139A2RGTT**



## TPA6139A2 DirectPath™ 25-mW Headphone Amplifier With Programmable-Fixed Gain

### 1 Features

- DirectPath™
  - Eliminates Pops and Clicks
  - Eliminates Output DC-Blocking Capacitors
  - 3-V to 3.6-V Supply Voltage
- Low Noise and THD
  - SNR > 105 dB at –1x Gain
  - Typical  $V_n < 15 \mu\text{Vms}$  20 to 20 kHz at –1x Gain
  - THD+N < 0.003% at 10-k $\Omega$  Load and –1x Gain
- 25 mW into 32- $\Omega$  Load
- 2-Vrms Output Voltage into 600- $\Omega$  Load
- Single-Ended Input and Output
- Programmable Gain Select Reduces Component Count
  - 13x Gain Values
- Active Mute With More Than 80-dB Attenuation
- Short-Circuit and Thermal Protection
- $\pm 8\text{-kV}$  HBM ESD Protected Outputs

### 2 Applications

- PDP and LCD TVs
- Blu-ray Discs™, DVD Players
- Mini and Micro Combo Systems
- Soundcards

Functional Block Diagram

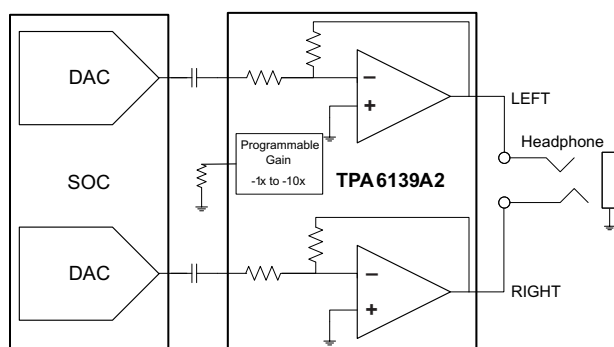

Copyright © 2016 Texas Instruments Incorporated

### 3 Description

The TPA6139A2 is a 25-mW, pop-free stereo headphone driver designed to reduce component count, board space and cost. It is ideal for single-supply electronics where size and cost are critical design parameters.

The TPA6139A2 device does not require a power supply greater than 3.3 V to generate its 25 mW, nor does it require a split rail power supply.

The TPA6139A2 device was designed using TI's patented DirectPath™ technology, which integrates a charge pump to generate a negative supply rail that provides a clean, pop-free ground biased output. The TPA6139A2 is capable of driving 25 mW into a 32- $\Omega$  load and 2 Vrms into a 600- $\Omega$  load. DirectPath also allows the removal of the costly output DC-blocking capacitors.

The device has fixed gain single-ended inputs with a gain select pin. Using a single resistor on this pin, the designer can choose from 13 internal programmable gain settings to match the line driver with the CODEC output level. It also reduces the component count and board space.

Headphone outputs have  $\pm 8\text{-kV}$  HBM ESD protection enabling a simple ESD protection circuit. The TPA6139A2 has built-in active mute control with more than 80-dB attenuation for pop-free mute ON and OFF control.

The TPA6139A2 device is available in a 14-pin TSSOP and a 16-pin QFN. For a pin-compatible, 2-Vrms line driver see [DRV612](#).

Device Information<sup>(1)</sup>

PART NUMBER	PACKAGE	BODY SIZE (NOM)
TPA6139A2	TSSOP (14)	5.00 mm × 4.40 mm
	VQFN (16)	3.00 mm × 3.00 mm

(1) For all available packages, see the orderable addendum at the end of the data sheet.



## Table of Contents

<b>1 Features</b> ..... 1 <b>2 Applications</b> ..... 1 <b>3 Description</b> ..... 1 <b>4 Revision History</b> ..... 2 <b>5 Device Comparison Table</b> ..... 3 <b>6 Pin Configuration and Functions</b> ..... 3 <b>7 Specifications</b> ..... 4 7.1 Absolute Maximum Ratings ..... 4 7.2 ESD Ratings ..... 4 7.3 Recommended Operating Conditions ..... 4 7.4 Thermal Information ..... 4 7.5 Electrical Characteristics ..... 5 7.6 Programmable Gain Settings ..... 6 7.7 Typical Characteristics, Line Driver ..... 7 <b>8 Parameter Measurement Information</b> ..... 8 <b>9 Detailed Description</b> ..... 9 9.1 Overview ..... 9 9.2 Functional Block Diagram ..... 9	9.3 Feature Description ..... 9 9.4 Device Functional Modes ..... 10 <b>10 Application and Implementation</b> ..... 12 10.1 Application Information ..... 12 10.2 Typical Application ..... 13 <b>11 Power Supply Recommendations</b> ..... 15 <b>12 Layout</b> ..... 15 12.1 Layout Guidelines ..... 15 12.2 Layout Example ..... 16 <b>13 Device and Documentation Support</b> ..... 18 13.1 Device Support ..... 18 13.2 Documentation Support ..... 18 13.3 Community Resources ..... 18 13.4 Trademarks ..... 18 13.5 Electrostatic Discharge Caution ..... 18 13.6 Glossary ..... 18 <b>14 Mechanical, Packaging, and Orderable Information</b> ..... 18
---	--

## 4 Revision History

NOTE: Page numbers for previous revisions may differ from page numbers in the current version.

Changes from Revision A (May 2011) to Revision C	Page
• Added <i>ESD Ratings</i> table, <i>Feature Description</i> section, <i>Device Functional Modes</i> , <i>Application and Implementation</i> section, <i>Power Supply Recommendations</i> section, <i>Layout</i> section, <i>Device and Documentation Support</i> section, and <i>Mechanical, Packaging, and Orderable Information</i> section. ....	1
• Removed <i>Ordering Information</i> table .....	1
• Changed 600-Ω Load value to 32-Ω Load in <i>Features</i> .....	1
• Changed 5-kΩ Load value to 600-Ω Load in <i>Features</i> .....	1
• Changed 2 V <sub>ms</sub> to 2 V <sub>rms</sub> in <i>Description</i> .....	1
• Added R <sub>L</sub> valuse for the MIN and MAX columns and changed the TYP value from 5 to 32 in the <i>Recommended Operating Conditions</i> .....	4
• Changed <i>Line Driver Amplifiers</i> subsection title to <i>DirectPath Headphone Driver</i> .....	9

Changes from Original (January 2011) to Revision A	Page
• Changed "2.5-mW" to "25-mW" in Title line and added revision A - May 2011 pub date to Header information .....	1
• Changed conditions statement from "R <sub>IN</sub> = 10 kΩ, R <sub>fb</sub> = 20 kΩ" to "Step = -2V/V" for TYP CHARA, LINE DRIVER section .....	7

## 5 Device Comparison Table

	TPA6132A2	TPA6136A2	TPA6139A2	TPA6141A2
Headphone Channels	Stereo	Stereo	Stereo	Stereo
Output Power (W)	0.025	0.025	0.025	0.025
Supply Voltage Range	2.3 to 5.5	2.3 to 5.5	3 to 3.6	2.5 to 5.5
PSRR (dB)	100	100	80	105
Pin and Package	16-pin WQFN	16-pin DSBGA	16-pin VQFN, 14-pin TSSOP	16-pin DSBGA

## 6 Pin Configuration and Functions

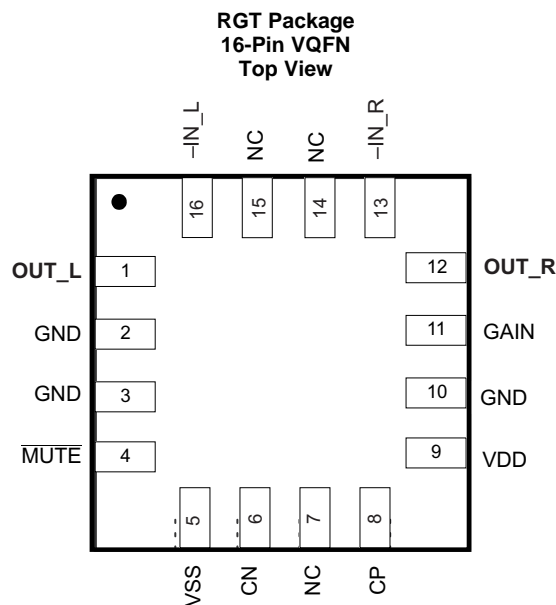
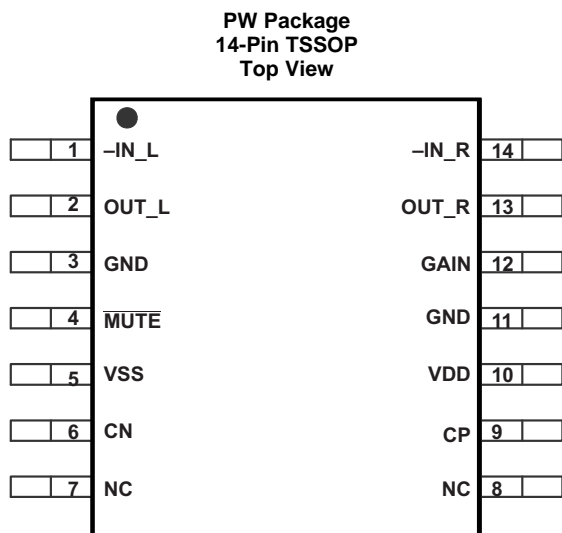

### Pin Functions

NAME	PIN		TYPE <sup>(1)</sup>	DESCRIPTION
	TSSOP	VQFN		
CN	6	6	I/O	Charge Pump flying capacitor negative connection
CP	9	8	I/O	Charge Pump flying capacitor positive connection
GAIN	12	11	I	Gain set programming pin; connect a resistor to ground. See <a href="#">Table 2</a> for recommended resistor values
GND	3, 11	2, 3, 10	P	Ground
-IN_L	1	16	I	Negative input, left channel
-IN_R	14	13	I	Negative input, right channel
MUTE	4	4	I	MUTE, active low
NC	7, 8	7, 14, 15	—	No internal connection
OUT_L	2	1	O	Output, left channel
OUT_R	13	12	O	Output, right channel
VDD	10	9	P	Supply voltage, connect to positive supply
VSS	5	5	O	Change Pump negative supply voltage

(1) I = input, O = output, P = power

## 7 Specifications

### 7.1 Absolute Maximum Ratings

over operating free-air temperature range (unless otherwise noted)<sup>(1)</sup>

	MIN	MAX	UNIT
VDD to GND	-0.3	4	V
Input voltage, $V_I$	VSS - 0.3	VDD + 0.3	V
$\overline{\text{MUTE}}$ to GND	-0.3	VDD + 0.3	V
Maximum operating junction temperature, $T_J$	-40	150	°C
Lead temperature		260	°C
Storage temperature, $T_{\text{stg}}$	-40	150	°C

(1) Stresses beyond those listed under *Absolute Maximum Ratings* may cause permanent damage to the device. These are stress ratings only, and functional operation of the device at these or any other conditions beyond those indicated under *Recommended Operating Conditions* is not implied. Exposure to absolute-maximum-rated conditions for extended periods may affect device reliability.

### 7.2 ESD Ratings

			VALUE	UNIT	
<b>TPA6139A2 IN PW PACKAGE</b>					
$V_{\text{(ESD)}}$	Electrostatic discharge	Human-body model (HBM), per ANSI/ESDA/JEDEC JS-001 <sup>(1)</sup>	All pins except 2 and 13	±4000	V
			Pins 2 and 13	±8000	
		Charged-device model (CDM), per JEDEC specification JESD22-C101 <sup>(2)</sup>		±1500	
<b>TPA6139A2 IN RGT PACKAGE</b>					
$V_{\text{(ESD)}}$	Electrostatic discharge	Human-body model (HBM), per ANSI/ESDA/JEDEC JS-001 <sup>(1)</sup>	All pins except 1 and 12	±4000	V
			Pins 1 and 12	±8000	
		Charged-device model (CDM), per JEDEC specification JESD22-C101 <sup>(2)</sup>		±1500	

(1) JEDEC document JEP155 states that 500-V HBM allows safe manufacturing with a standard ESD control process.

(2) JEDEC document JEP157 states that 250-V CDM allows safe manufacturing with a standard ESD control process.

### 7.3 Recommended Operating Conditions

over operating free-air temperature range unless otherwise noted

			MIN	NOM	MAX	UNIT
VDD	Supply voltage	DC supply voltage	3	3.3	3.6	V
$R_L$	Load resistance		16	32	10000	Ω
$V_{\text{IL}}$	Low-level input voltage	$\overline{\text{MUTE}}$	38	40	43	%PVDD
$V_{\text{IH}}$	High-level input voltage	$\overline{\text{MUTE}}$	57	60	66	%PVDD
$T_A$	Free-air temperature		-40	25	85	°C

### 7.4 Thermal Information

THERMAL METRIC <sup>(1)</sup>		TPA6139A2		UNIT
		PW (TSSOP)	RGT (VQFN)	
		14 PINS	16 PINS	
$R_{\theta\text{JA}}$	Junction-to-ambient thermal resistance	130	52	°C/W
$R_{\theta\text{JC(top)}}$	Junction-to-case (top) thermal resistance	49	71	°C/W
$R_{\theta\text{JB}}$	Junction-to-board thermal resistance	63	26	°C/W
$\Psi_{\text{JT}}$	Junction-to-top characterization parameter	3.6	3	°C/W
$\Psi_{\text{JB}}$	Junction-to-board characterization parameter	62	26	°C/W
$R_{\theta\text{JC(bot)}}$	Junction-to-case (bottom) thermal resistance	—	9.8	°C/W

(1) For more information about traditional and new thermal metrics, see the *Semiconductor and IC Package Thermal Metrics* application report, [SPRA953](#).

## 7.5 Electrical Characteristics

VDD = 3.3 V, R<sub>Load</sub> = 32 Ω, T<sub>A</sub> = 25°C, Charge pump: C<sub>CP</sub> = 1 μF (unless otherwise noted)

PARAMETER		TEST CONDITIONS	MIN	TYP	MAX	UNIT
V <sub>OS</sub>	Output offset voltage	VDD = 3.3 V, input AC-coupled		0.5	1	mV
PSRR	Power-supply rejection ratio		70	80		dB
V <sub>OH</sub>	High-level output voltage	VDD = 3.3 V	3.1			V
V <sub>OL</sub>	Low-level output voltage	VDD = 3.3 V			-3.05	V
V <sub>uvp_on</sub>	PVDD, under voltage detection				2.8	V
V <sub>uvp_hysteresis</sub>	PVDD, under voltage detection, hysteresis			200		mV
F <sub>cp</sub>	Charge pump switching frequency			350		kHz
I <sub>IH</sub>	High-level input current, $\overline{\text{MUTE}}$	VDD = 3.3 V, V <sub>IH</sub> = VDD			1	μA
I <sub>IL</sub>	Low-level input current, $\overline{\text{MUTE}}$	VDD = 3.3 V, V <sub>IL</sub> = 0 V			1	μA
I (VDD)	Supply current, no load	VDD, $\overline{\text{MUTE}}$ = 3.3 V		25		mA
	Supply current, MUTED	VDD = 3.3 V, $\overline{\text{MUTE}}$ = GND		25		mA
T <sub>sd</sub>	Thermal shutdown			150		°C
	Thermal shutdown hysteresis			15		°C
P <sub>O</sub>	Output Power, outputs in phase	THD+N = 1%, f = 1 kHz, 32-Ω load		25		mW
V <sub>O</sub>	Output Voltage, outputs in phase	THD+N = 1%, f = 1 kHz, 32-Ω load		0.9		V <sub>rms</sub>
		THD+N = 1%, f = 1 kHz, 600-Ω load		2		
THD+N	Total Harmonic distortion plus noise	f = 1kHz, 32-Ω load, P <sub>o</sub> = 25 mW, -1x gain		0.03%		
THD+N	Total Harmonic distortion plus noise	f = 1kHz, 10-kΩ load, V <sub>o</sub> = 2 V <sub>rms</sub> , -1x gain		0.005%		
ΔA <sub>V</sub>	Gain matching	Between left and right channels		0.25		dB
Z <sub>O</sub>	Output impedance when muted	$\overline{\text{MUTE}}$ = GND			1	Ω
	Input to output attenuation when muted	$\overline{\text{MUTE}}$ = GND		80		dB
SNR	Signal to noise ratio	A-weighted, AES17 filter, 1-V <sub>rms</sub> ref 32-Ω load, -1x gain		99		dB
	Signal to noise ratio	A-weighted, AES17 filter, 2-V <sub>rms</sub> ref 600-Ω load, -1x gain		105		dB
V <sub>n</sub>	Noise voltage	A-weighted, AES17 filter, Gain = -2x		12		μV
	Slew rate			4.5		V/μs
G <sub>bw</sub>	Unity gain bandwidth			8		MHz
Crosstalk	Channel to channel	f = 1 kHz, R <sub>load</sub> = 32 Ω, P <sub>o</sub> = 25 mW		-85		dB
V <sub>incm_pos</sub>	Positive common-mode input voltage			+2		V
V <sub>incm_neg</sub>	Negative common-mode input voltage			-2		V
I <sub>lim</sub>	Output current limit			60		mA

## 7.6 Programmable Gain Settings

 $V_{DD} = 3.3\text{ V}$ ,  $R_{load} = 32\text{ k}\Omega$ ,  $T_A = 25^\circ\text{C}$ , Charge pump:=  $C_{CP} = 1\text{ }\mu\text{F}$ ,  $C_{IN} = 1\text{ }\mu\text{F}$ , 1x gain select (unless otherwise noted)<sup>(1)</sup>

PARAMETER		TEST CONDITIONS	MIN	TYP	MAX	UNIT
R_Tol	Gain programming resistor tolerance				2%	
$\Delta A_V$	Gain matching	Between left and right channels		0.25		dB
	Gain step tolerance			0.1		dB
Gain steps	Gain resistor 2% tolerance	249k or higher		-2		V/V
		82k0		-1		
		49k2		-1.5		
		35k1		-2.3		
		27k3		-2.5		
		20k5		-3		
		15k4		-3.5		
		11k5		-4		
		9k09		-5		
		7k50		-5.6		
		6k19		-6.4		
		5k11		-8.3		
		3k90		-10		
Input impedance	Gain resistor 2% tolerance	249k or higher		37		k $\Omega$
		82k0		55		
		49k2		44		
		35k1		33		
		27k3		31		
		20k5		28		
		15k4		24		
		11k5		22		
		9k09		18		
		7k50		17		
		6k19		15		
		5k11		12		
		3k90		10		

(1) If pin 12, GAIN, is left floating an internal pullup sets the gain to -2x. Gain setting is latched during power up.

### 7.7 Typical Characteristics, Line Driver

$V_{DD} = 3.3\text{ V}$ ,  $T_A = 25^\circ\text{C}$ ,  $R_L = 2.5\text{ k}\Omega$ ,  $C_{PUMP} = C_{(VSS)} = 10\text{ }\mu\text{F}$ , Gain Step =  $-2\text{ V/V}$  (unless otherwise noted)

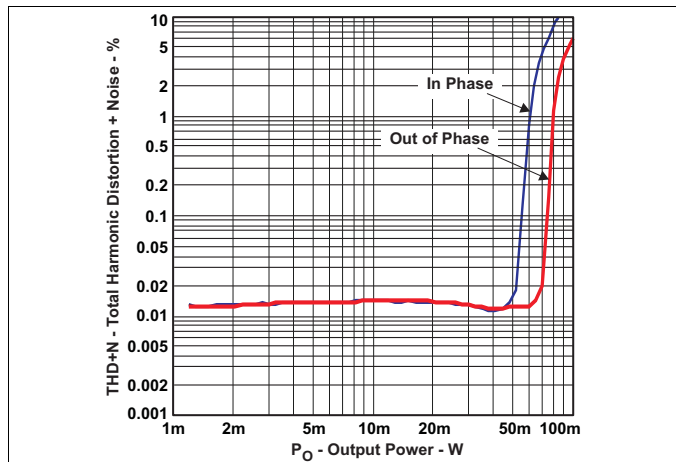

3.3 V, 100 k $\Omega$ , 1 kHz

Figure 1. THD+N vs Output Voltage

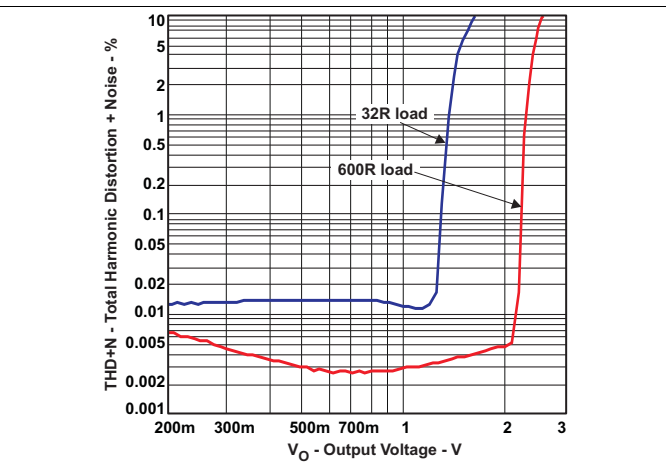

3.3 V, 600- $\Omega$  load, 1 kHz

Figure 2. THD+N vs Output Voltage

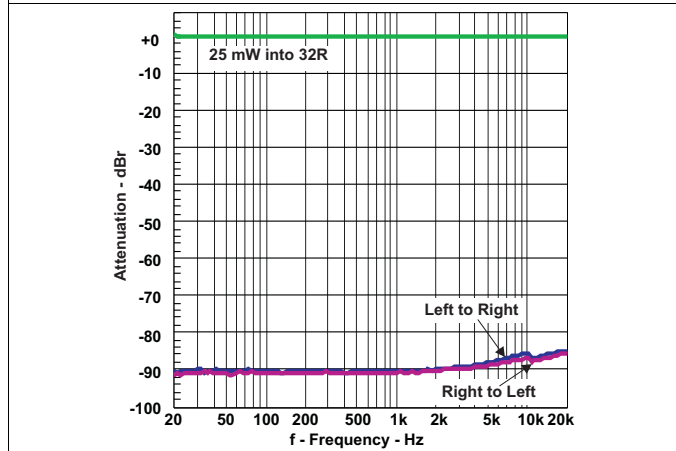

3.3 V, 5-k $\Omega$  load, 2 V<sub>rms</sub>, Blue L to R, Red R to L

Figure 3. Channel Separation

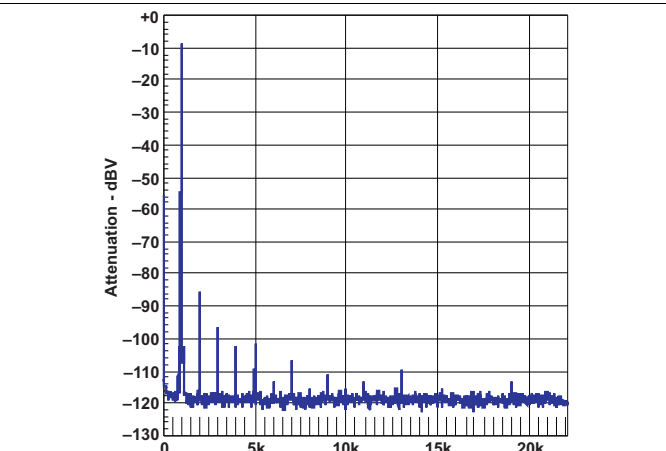

Figure 4. FFT

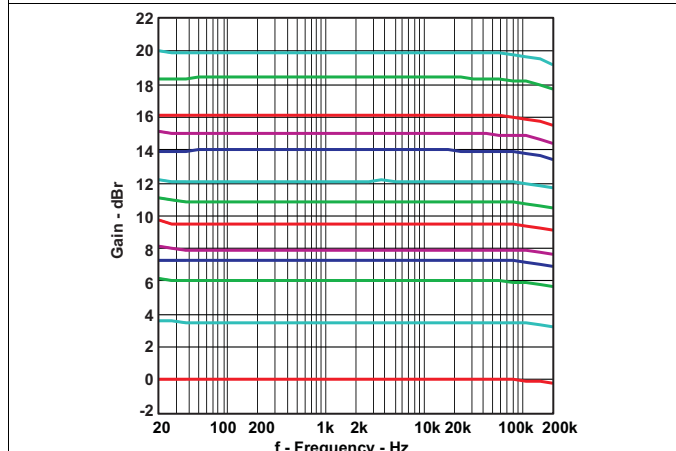

Figure 5. Gain vs Frequency

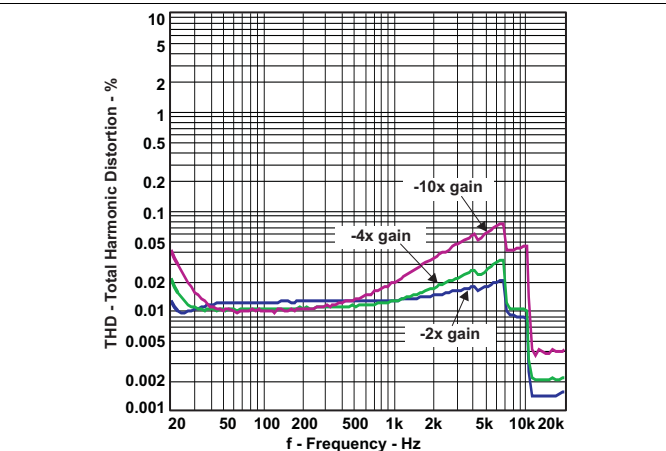
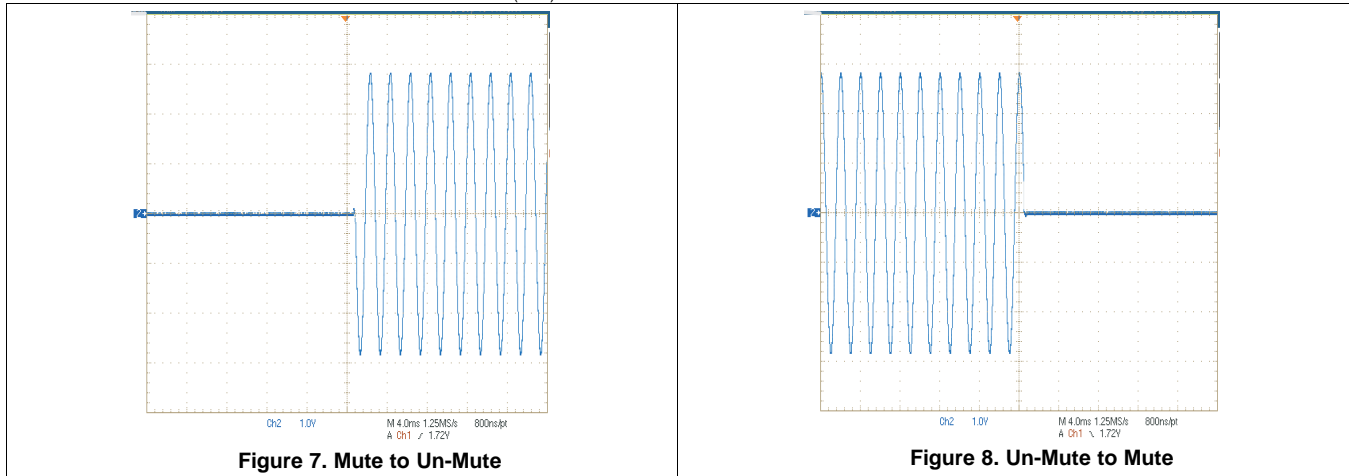

Figure 6. Total Harmonic Distortion vs Frequency

## Typical Characteristics, Line Driver (continued)

$V_{DD} = 3.3\text{ V}$ ,  $T_A = 25^\circ\text{C}$ ,  $R_L = 2.5\text{ k}\Omega$ ,  $C_{PUMP} = C_{(VSS)} = 10\text{ }\mu\text{F}$ , Gain Step =  $-2\text{ V/V}$  (unless otherwise noted)



## 8 Parameter Measurement Information

All parameters are measured according to the conditions described in the [Specifications](#) section.

## 9 Detailed Description

### 9.1 Overview

The TPA6139A2 is a DirectPath stereo headphone amplifier that requires no output DC-blocking capacitors and is capable of delivering 25 mW into a 32-Ω load. The device has built-in pop suppression circuitry to completely eliminate pop noise during turnon and turnoff. The amplifier outputs have short-circuit protection.

The TPA6139A2 gain is controlled by external resistors  $R_{in}$  and  $R_{fb}$ , see [Gain Setting](#) for recommended values.

The TPA6139A2 operates from a single 3-V to 3.6-V supply, as it uses a built-in charge pump to generate a negative voltage supply for the headphone amplifiers.

### 9.2 Functional Block Diagram

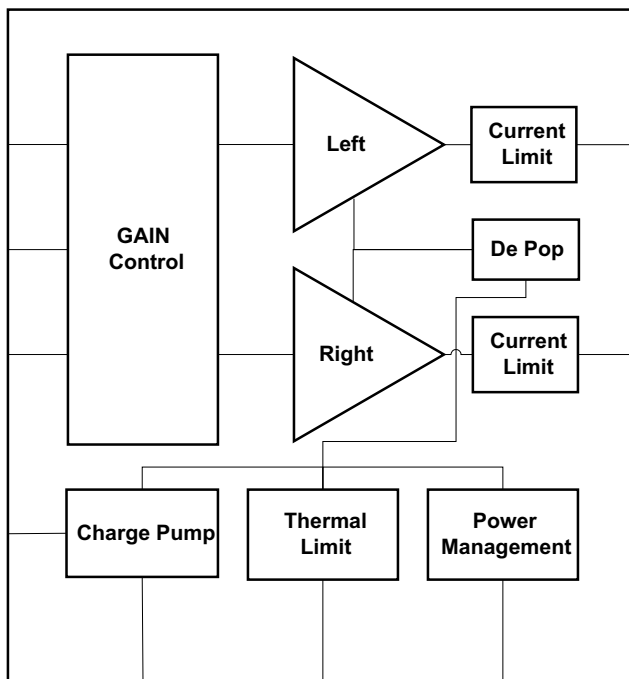

Copyright © 2016 Texas Instruments Incorporated

### 9.3 Feature Description

#### 9.3.1 DirectPath Headphone Driver

Single-supply line-driver amplifiers typically require DC-blocking capacitors. The top drawing in [Figure 9](#) illustrates the conventional line-driver amplifier connection to the load and output signal.

DC-blocking capacitors are often large in value, and a mute circuit is needed during power up to minimize click and pop. The output capacitor and mute circuit consume PCB area and increase cost of assembly, and can reduce the fidelity of the audio output signal.

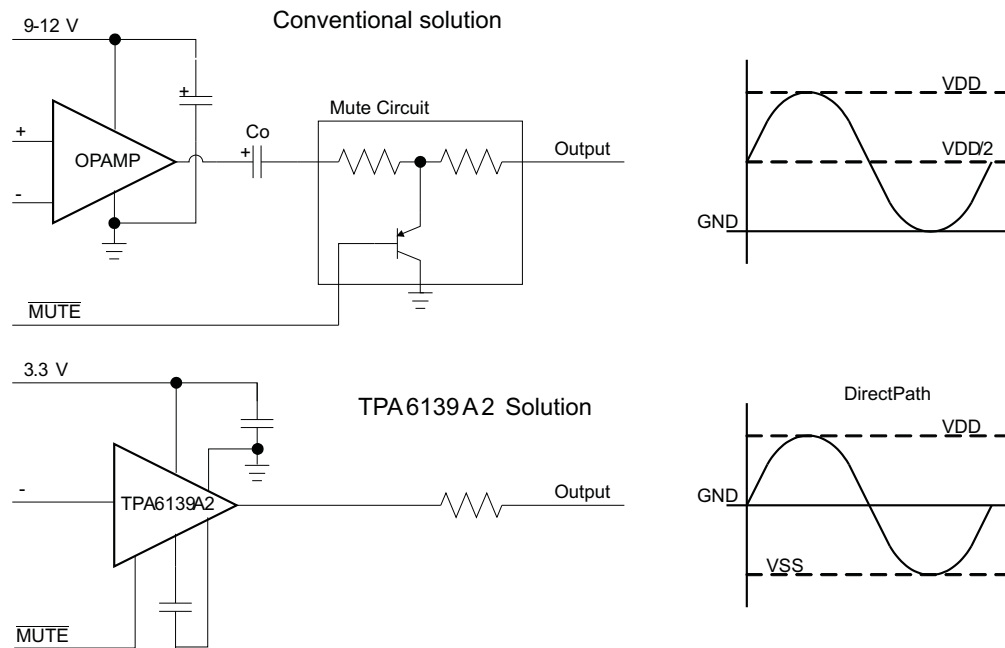
**Feature Description (continued)**

**Figure 9. Conventional and DirectPath Line Driver**

The DirectPath amplifier architecture operates from a single supply but makes use of an internal charge pump to provide a negative voltage rail.

Combining the user-provided positive rail and the negative rail generated by the IC, the device operates in what is effectively a split supply mode.

The output voltages are now centered at zero volts with the capability to swing to the positive rail or negative rail. Combining this with the built-in click and pop reduction circuit, the DirectPath amplifier requires no output DC-blocking capacitors.

The bottom block diagram and waveform of [Figure 9](#) illustrate the ground-referenced line-driver architecture.

## 9.4 Device Functional Modes

### 9.4.1 Internal Undervoltage Detection

The TPA6139A2 contains an internal precision band-gap reference voltage and a comparator used to monitor the supply voltage, VDD. The internal VDD monitor is set at 2.8 V with 200-mV hysteresis.

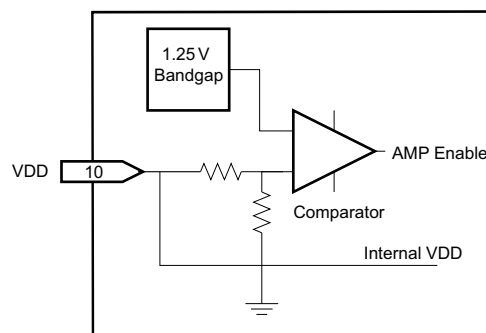

## Device Functional Modes (continued)

### 9.4.2 Pop-Free Power Up

Pop-free power up is ensured by keeping the  $\overline{\text{MUTE}}$  low during power-supply ramp-up and ramp-down. The pin must be kept low until the input AC-coupling capacitors are fully charged before asserting the  $\overline{\text{MUTE}}$  pin high to precharge the AC-coupling; and, pop-less power up is achieved. Figure 10 illustrates the preferred sequence.

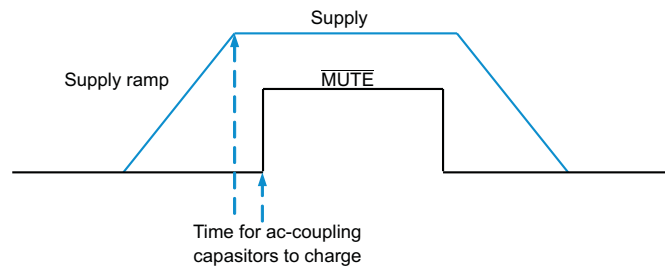

**Figure 10. Power-Up Sequence**

## 10 Application and Implementation

---

### NOTE

Information in the following applications sections is not part of the TI component specification, and TI does not warrant its accuracy or completeness. TI's customers are responsible for determining suitability of components for their purposes. Customers should validate and test their design implementation to confirm system functionality.

---

### 10.1 Application Information

The TPA6139A2 device starts its operation by asserting the MUTE pin to logic 1. The device enters in mute mode when pulling the MUTE pin low. The charge pump generates a negative supply voltage. The charge pump flying capacitor connected between CP and CN transfers charge to generate the negative supply voltage. The output voltages are capable of positive and negative voltage swings and are centered close to 0 V, eliminating the need for output capacitors. Input coupling capacitors block any DC bias from the audio source and ensure maximum dynamic range.

This typical connection diagram highlights the required external components and system level connections for proper operation of the device in popular use case. Any design variation can be supported by TI through schematic and layout reviews. Visit <https://e2e.ti.com> for design assistance and join the audio amplifier discussion forum for additional information.

#### 10.1.1 Capacitive Load

The TPA6139A2 has the ability to drive a high capacitive load up to 220 pF directly. Higher capacitive loads can be accepted by adding a series resistor of 47  $\Omega$  or larger for the line driver output.

## 10.2 Typical Application

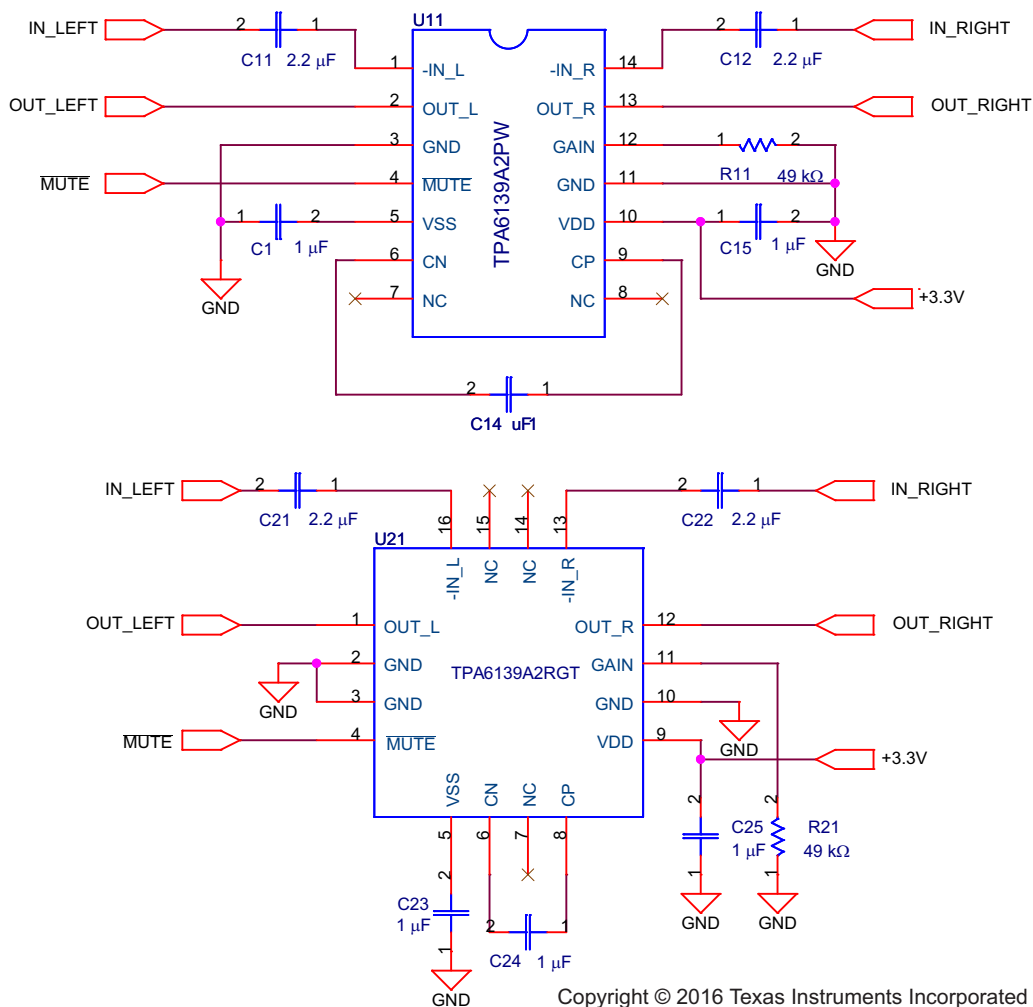

Figure 11. Single-Ended Input and Output, Gain Set to  $-1.5x$

### 10.2.1 Design Requirements

Table 1 lists the design parameters of this example.

Table 1. Design Parameters

DESIGN PARAMETER	EXAMPLE VALUE
Input voltage supply range	3 V to 3.6 V
Current	130 mA
Load impedance	32 $\Omega$

### 10.2.2 Detailed Design Procedure

#### 10.2.2.1 Component Selection

##### 10.2.2.1.1 Charge Pump

The charge pump flying capacitor serves to transfer charge during the generation of the negative supply voltage. The VSS capacitor must be at least equal to the charge pump capacitor in order to allow maximum charge transfer. Low ESR capacitors are an ideal selection, and a value of 1  $\mu\text{F}$  is typical. Capacitor values that are smaller than 1  $\mu\text{F}$  cannot be recommended as it limits the negative voltage swing in low impedance loads.

### 10.2.2.1.2 Decoupling Capacitors

The TPA6139A2 is a DirectPath amplifier that requires adequate power-supply decoupling to ensure that the noise and total harmonic distortion (THD) are low. A good low equivalent-series-resistance (ESR) ceramic capacitor, typically 1  $\mu\text{F}$ , placed as close as possible to the device VDD leads works best. Placing this decoupling capacitor close to the TPA6139A2 is important for the performance of the amplifier. For filtering lower frequency noise signals, a 10- $\mu\text{F}$  or greater capacitor placed near the audio power amplifier also helps, but it is not required in most applications because of the high PSRR of this device.

### 10.2.2.1.3 Gain Setting

The gain setting is programmed with the GAIN pin individually for line driver and headphone section. Gain setting is latched when the MUTE pin is set high. [Table 2](#) lists the gain settings. The default gain with the gain-set pin left open is  $-2x$ .

**Table 2. Gain Settings**

Gain_set RESISTOR	GAIN	GAIN (dB)	INPUT RESISTANCE
No connect	$-2x$	6	37k
82k0	$-1x$	0	55k
49k2	$-1.5x$	3.5	44k
35k1	$-2.3x$	7.2	33k
27k3	$-2.5x$	8	31k
20k5	$-3x$	9.5	28k
15k4	$-3.5x$	10.9	24k
11k5	$-4x$	12	22k
9k09	$-5x$	14	18k
7k50	$-5.6x$	15	17k
6k19	$-6.4x$	16.1	15k
5k11	$-8.3x$	18.4	12k
3k90	$-10x$	20	10k

### 10.2.2.1.4 Input-Blocking Capacitors

DC input-blocking capacitors are required to be added in series with the audio signal into the input pins of the TPA6139A2. These capacitors block the DC portion of the audio source and allow the TPA6139A2 inputs to be properly biased to provide maximum performance. The input blocking capacitors also limit the DC gain to 1, limiting the DC-offset voltage at the output.

These capacitors form a high-pass filter with the input resistor,  $R_{IN}$ . The cutoff frequency is calculated using [Equation 1](#). For this calculation, the capacitance used is the input-blocking capacitor and the resistance is the input resistor chosen from [Table 2](#). Then the frequency or capacitance can be determined when one of the two values is given, as shown in [Equation 1](#).

$$f_{C_{IN}} = \frac{1}{2\pi R_{IN} C_{IN}} \text{ or } C_{IN} = \frac{1}{2\pi f_{C_{IN}} R_{IN}} \quad (1)$$

For a fixed cutoff frequency of 2 Hz, the size of the input capacitance is shown [Table 3](#) with the capacitors rounded up to the nearest E6 values. For 20-Hz cutoff, simply divide the capacitor values with 10; for example, for 1x gain, 150 nF is needed.

**Table 3. Input Capacitor for Different Gain and Cutoff**

Gain_set RESISTOR	GAIN	Gain (dB)	INPUT RESISTANCE	2-Hz CUTOFF
249k	$-2x$	6	37k	2.2 $\mu\text{F}$
82k0	$-1x$	0	55k	1.5 $\mu\text{F}$
49k2	$-1.5x$	3.5	44k	2.2 $\mu\text{F}$
35k1	$-2.3x$	7.2	33k	3.3 $\mu\text{F}$
27k3	$-2.5x$	8	31k	3.3 $\mu\text{F}$

**Table 3. Input Capacitor for Different Gain and Cutoff (continued)**

Gain_set RESISTOR	GAIN	Gain (dB)	INPUT RESISTANCE	2-Hz CUTOFF
20k5	–3x	9.5	28k	3.3 $\mu$ F
15k4	–3.5x	10.9	24k	3.3 $\mu$ F
11k5	–4x	12	22k	4.7 $\mu$ F
9k09	–5x	14	18k	4.7 $\mu$ F
7k50	–5.6x	15	17k	4.7 $\mu$ F
6k19	–6.4x	16.1	15k	6.8 $\mu$ F
5k11	–8.3x	18.4	12k	6.8 $\mu$ F
3k90	–10x	20	10k	10 $\mu$ F

### 10.2.3 Application Curves

The characteristics of this design are shown in [Typical Characteristics, Line Driver](#).

**Table 4. Table of Graphs**

	FIGURE
THD+N vs Output Voltage	<a href="#">Figure 2</a>
Total Harmonic Distortion vs Frequency	<a href="#">Figure 6</a>
Mute to Un-Mute	<a href="#">Figure 7</a>
Un-Mute to mute	<a href="#">Figure 8</a>

## 11 Power Supply Recommendations

The device is designed to operate from an input voltage supply from 3 V to 3.6 V. Therefore, the output voltage range of power supply should be within this range and well regulated. TI recommends placing decoupling capacitors in every voltage source pin. Place these decoupling capacitors as close as possible to the TPA6139A2.

## 12 Layout

### 12.1 Layout Guidelines

A proposed layout for the TPA6139A2 can be seen in the TPA6139A2EVM User's Guide ([SLOU308](#)), and the Gerber files can be downloaded from <http://focus.ti.com/docs/toolsw/folders/print/TPA6139A2evm.html>. To access this information, open the TPA6139A2 product folder and look in the Tools and Software folder.

TI recommends routing the ground traces as a star ground to minimize hum interference. VDD, VSS decoupling capacitors, and the charge pump capacitors should be connected with short traces.

The TPA6139A2 stereo headphone amplifier is pin-compatible with the DRV612. A single PCB layout can therefore be used with stuffing options for different board configurations.

## 12.2 Layout Example

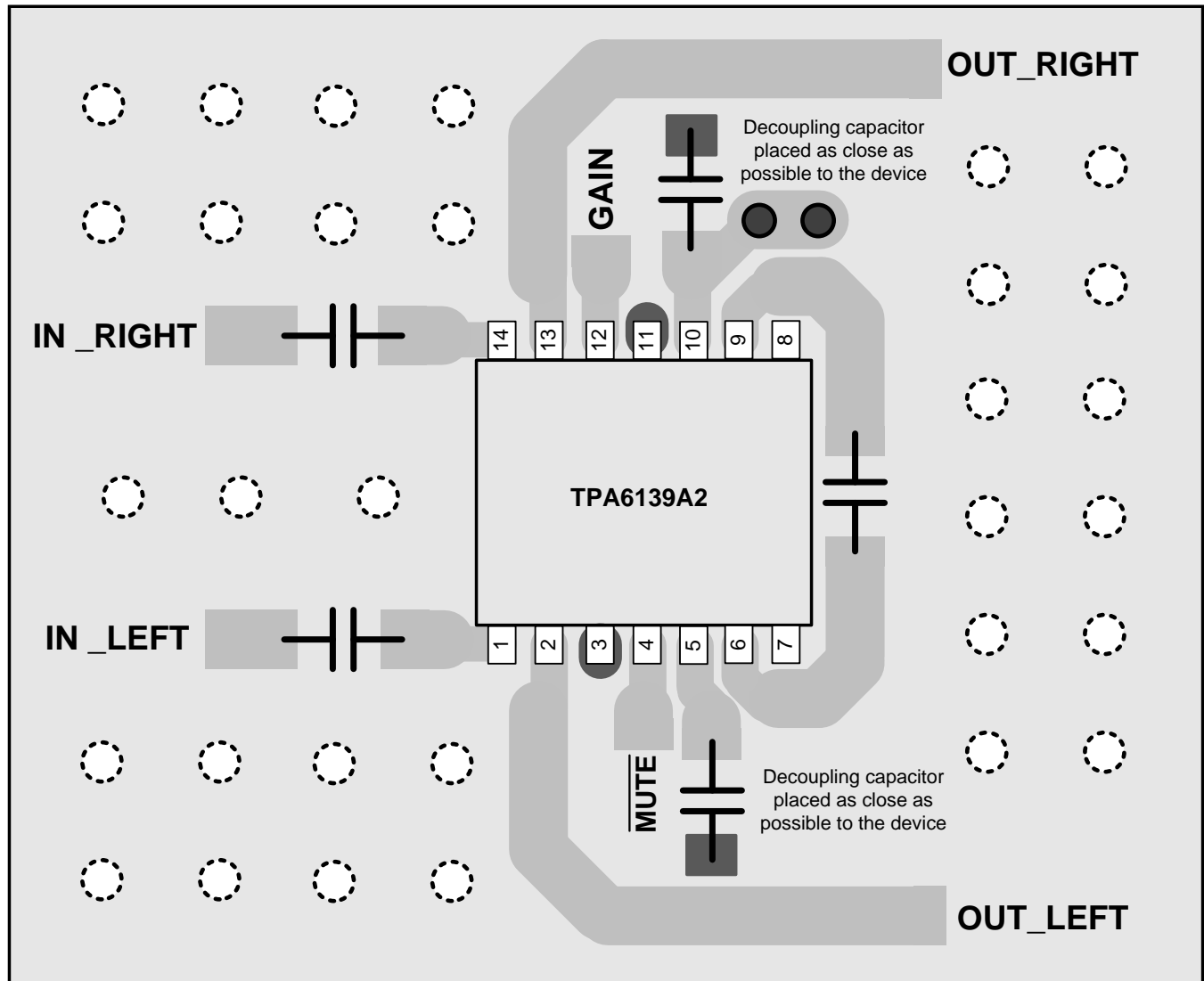
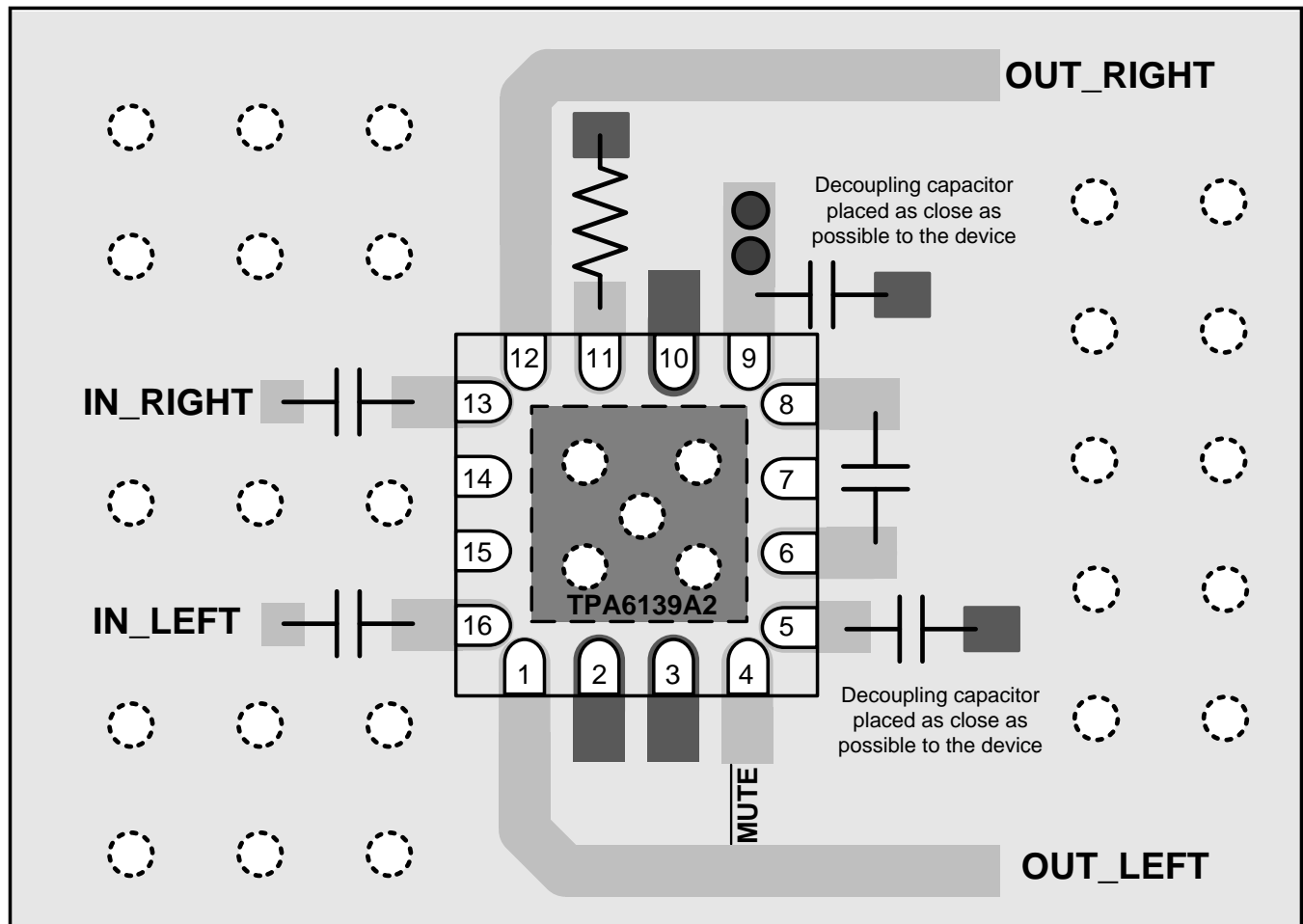

Figure 12. Layout Example for the TSSOP Package

Layout Example (continued)







- |   |  |
|---|--|
|  Top Layer Ground Plane        |  Top Layer Traces    |
|  Pad to Top Layer Ground Plane |  Thermal Pad         |
|  Via to Bottom Ground Plane    |  Via to Power Supply |

Figure 13. Layout Example for the VQFN Package

## 13 Device and Documentation Support

### 13.1 Device Support

For device support, see the following:

Gerber – <http://focus.ti.com/docs/toolsw/folders/print/TPA6139A2evm.html>

### 13.2 Documentation Support

For related documentation, see the following:

*TPA6139A2EVM User's Guide* ([SLOU308](#))

### 13.3 Community Resources

The following links connect to TI community resources. Linked contents are provided "AS IS" by the respective contributors. They do not constitute TI specifications and do not necessarily reflect TI's views; see TI's [Terms of Use](#).

**TI E2E™ Online Community** *TI's Engineer-to-Engineer (E2E) Community*. Created to foster collaboration among engineers. At [e2e.ti.com](http://e2e.ti.com), you can ask questions, share knowledge, explore ideas and help solve problems with fellow engineers.

**Design Support** *TI's Design Support* Quickly find helpful E2E forums along with design support tools and contact information for technical support.

### 13.4 Trademarks

DirectPath, E2E are trademarks of Texas Instruments.  
 Blu-ray Discs is a trademark of Blu-ray Disc Association.  
 All other trademarks are the property of their respective owners.

### 13.5 Electrostatic Discharge Caution



These devices have limited built-in ESD protection. The leads should be shorted together or the device placed in conductive foam during storage or handling to prevent electrostatic damage to the MOS gates.

### 13.6 Glossary

[SLYZ022](#) — *TI Glossary*.

This glossary lists and explains terms, acronyms, and definitions.

## 14 Mechanical, Packaging, and Orderable Information

The following pages include mechanical, packaging, and orderable information. This information is the most current data available for the designated devices. This data is subject to change without notice and revision of this document. For browser-based versions of this data sheet, refer to the left-hand navigation.

**PACKAGING INFORMATION**

Orderable Device	Status (1)	Package Type	Package Drawing	Pins	Package Qty	Eco Plan (2)	Lead finish/ Ball material (6)	MSL Peak Temp (3)	Op Temp (°C)	Device Marking (4/5)	Samples
TPA6139A2PW	ACTIVE	TSSOP	PW	14	90	RoHS & Green	NIPDAU	Level-2-260C-1 YEAR	-40 to 85	TPA6139	<a href="#">Samples</a>
TPA6139A2PWR	ACTIVE	TSSOP	PW	14	2000	RoHS & Green	NIPDAU	Level-2-260C-1 YEAR	-40 to 85	TPA6139	<a href="#">Samples</a>
TPA6139A2RGTR	ACTIVE	VQFN	RGT	16	3000	RoHS & Green	NIPDAU	Level-2-260C-1 YEAR	-40 to 150	T6139	<a href="#">Samples</a>
TPA6139A2RGTT	ACTIVE	VQFN	RGT	16	250	RoHS & Green	NIPDAU	Level-2-260C-1 YEAR	-40 to 150	T6139	<a href="#">Samples</a>

(1) The marketing status values are defined as follows:

**ACTIVE:** Product device recommended for new designs.

**LIFEBUY:** TI has announced that the device will be discontinued, and a lifetime-buy period is in effect.

**NRND:** Not recommended for new designs. Device is in production to support existing customers, but TI does not recommend using this part in a new design.

**PREVIEW:** Device has been announced but is not in production. Samples may or may not be available.

**OBSOLETE:** TI has discontinued the production of the device.

(2) **RoHS:** TI defines "RoHS" to mean semiconductor products that are compliant with the current EU RoHS requirements for all 10 RoHS substances, including the requirement that RoHS substance do not exceed 0.1% by weight in homogeneous materials. Where designed to be soldered at high temperatures, "RoHS" products are suitable for use in specified lead-free processes. TI may reference these types of products as "Pb-Free".

**RoHS Exempt:** TI defines "RoHS Exempt" to mean products that contain lead but are compliant with EU RoHS pursuant to a specific EU RoHS exemption.

**Green:** TI defines "Green" to mean the content of Chlorine (Cl) and Bromine (Br) based flame retardants meet JS709B low halogen requirements of <=1000ppm threshold. Antimony trioxide based flame retardants must also meet the <=1000ppm threshold requirement.

(3) MSL, Peak Temp. - The Moisture Sensitivity Level rating according to the JEDEC industry standard classifications, and peak solder temperature.

(4) There may be additional marking, which relates to the logo, the lot trace code information, or the environmental category on the device.

(5) Multiple Device Markings will be inside parentheses. Only one Device Marking contained in parentheses and separated by a "-" will appear on a device. If a line is indented then it is a continuation of the previous line and the two combined represent the entire Device Marking for that device.

(6) Lead finish/Ball material - Orderable Devices may have multiple material finish options. Finish options are separated by a vertical ruled line. Lead finish/Ball material values may wrap to two lines if the finish value exceeds the maximum column width.

**Important Information and Disclaimer:**The information provided on this page represents TI's knowledge and belief as of the date that it is provided. TI bases its knowledge and belief on information provided by third parties, and makes no representation or warranty as to the accuracy of such information. Efforts are underway to better integrate information from third parties. TI has taken and

continues to take reasonable steps to provide representative and accurate information but may not have conducted destructive testing or chemical analysis on incoming materials and chemicals. TI and TI suppliers consider certain information to be proprietary, and thus CAS numbers and other limited information may not be available for release.

In no event shall TI's liability arising out of such information exceed the total purchase price of the TI part(s) at issue in this document sold by TI to Customer on an annual basis.

**TAPE AND REEL INFORMATION**

**QUADRANT ASSIGNMENTS FOR PIN 1 ORIENTATION IN TAPE**



\*All dimensions are nominal

Device	Package Type	Package Drawing	Pins	SPQ	Reel Diameter (mm)	Reel Width W1 (mm)	A0 (mm)	B0 (mm)	K0 (mm)	P1 (mm)	W (mm)	Pin1 Quadrant
TPA6139A2PWR	TSSOP	PW	14	2000	330.0	12.4	6.9	5.6	1.6	8.0	12.0	Q1

**TAPE AND REEL BOX DIMENSIONS**

\*All dimensions are nominal

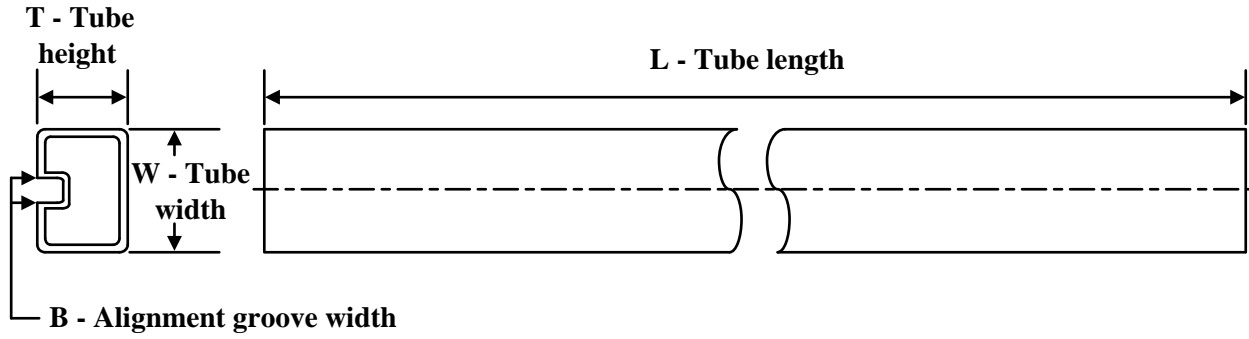
Device	Package Type	Package Drawing	Pins	SPQ	Length (mm)	Width (mm)	Height (mm)
TPA6139A2PWR	TSSOP	PW	14	2000	350.0	350.0	43.0

**TUBE**

\*All dimensions are nominal

Device	Package Name	Package Type	Pins	SPQ	L (mm)	W (mm)	T (μm)	B (mm)
TPA6139A2PW	PW	TSSOP	14	90	530	10.2	3600	3.5

**TRAY**

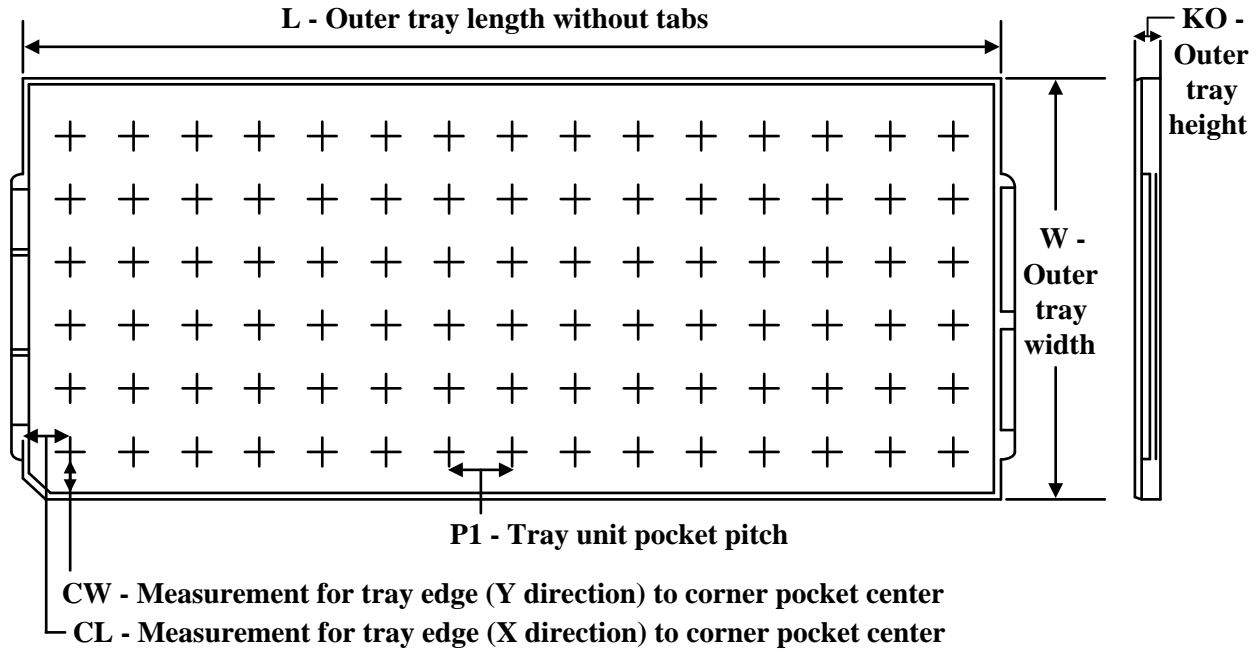

Chamfer on Tray corner indicates Pin 1 orientation of packed units.

\*All dimensions are nominal

Device	Package Name	Package Type	Pins	SPQ	Unit array matrix	Max temperature (°C)	L (mm)	W (mm)	K0 (µm)	P1 (mm)	CL (mm)	CW (mm)
TPA6139A2RGTR	RGT	VQFN	16	3000	35 X 14	150	315	135.9	7620	8.8	7.9	8.15
TPA6139A2RGTT	RGT	VQFN	16	250	35 X 14	150	315	135.9	7620	8.8	7.9	8.15



PW (R-PDSO-G14)

PLASTIC SMALL OUTLINE



4211284-2/G 08/15

- NOTES:
- All linear dimensions are in millimeters.
  - This drawing is subject to change without notice.
  - Publication IPC-7351 is recommended for alternate designs.
  - Laser cutting apertures with trapezoidal walls and also rounding corners will offer better paste release. Customers should contact their board assembly site for stencil design recommendations. Refer to IPC-7525 for other stencil recommendations.
  - Customers should contact their board fabrication site for solder mask tolerances between and around signal pads.

**RGT 16**

**GENERIC PACKAGE VIEW**

**VQFN - 1 mm max height**

PLASTIC QUAD FLATPACK - NO LEAD

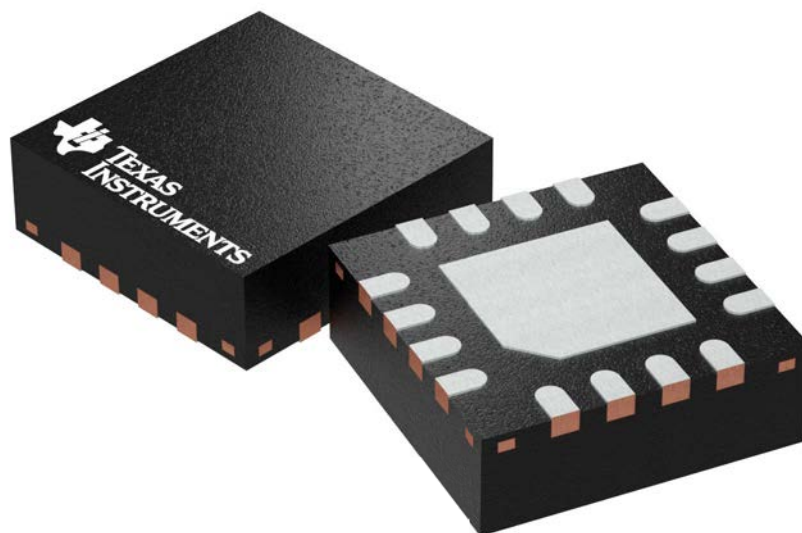

Images above are just a representation of the package family, actual package may vary.  
Refer to the product data sheet for package details.

4203495/1

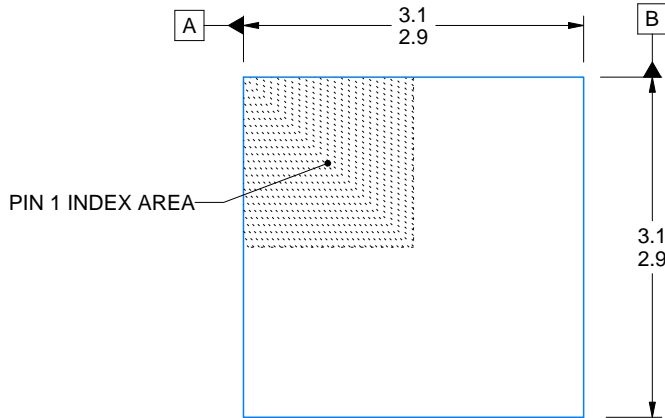
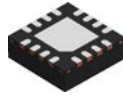

SIDE WALL METAL THICKNESS DIM A	
OPTION 1	OPTION 2
0.1	0.2

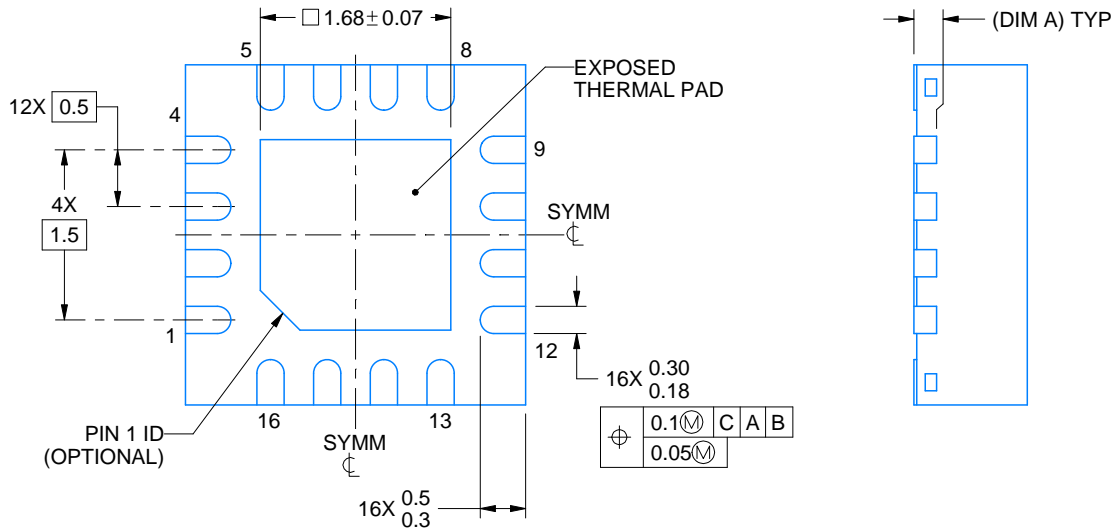
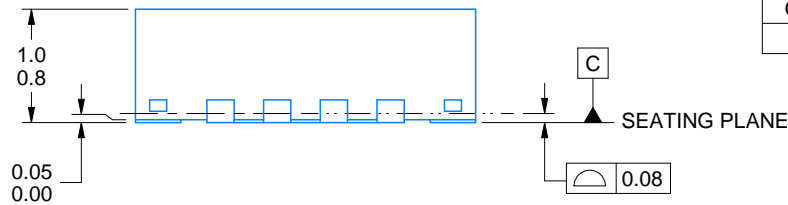

4222419/D 04/2022

NOTES:

1. All linear dimensions are in millimeters. Any dimensions in parenthesis are for reference only. Dimensioning and tolerancing per ASME Y14.5M.
2. This drawing is subject to change without notice.
3. The package thermal pad must be soldered to the printed circuit board for thermal and mechanical performance.



# EXAMPLE STENCIL DESIGN

RGT0016C

VQFN - 1 mm max height

PLASTIC QUAD FLATPACK - NO LEAD

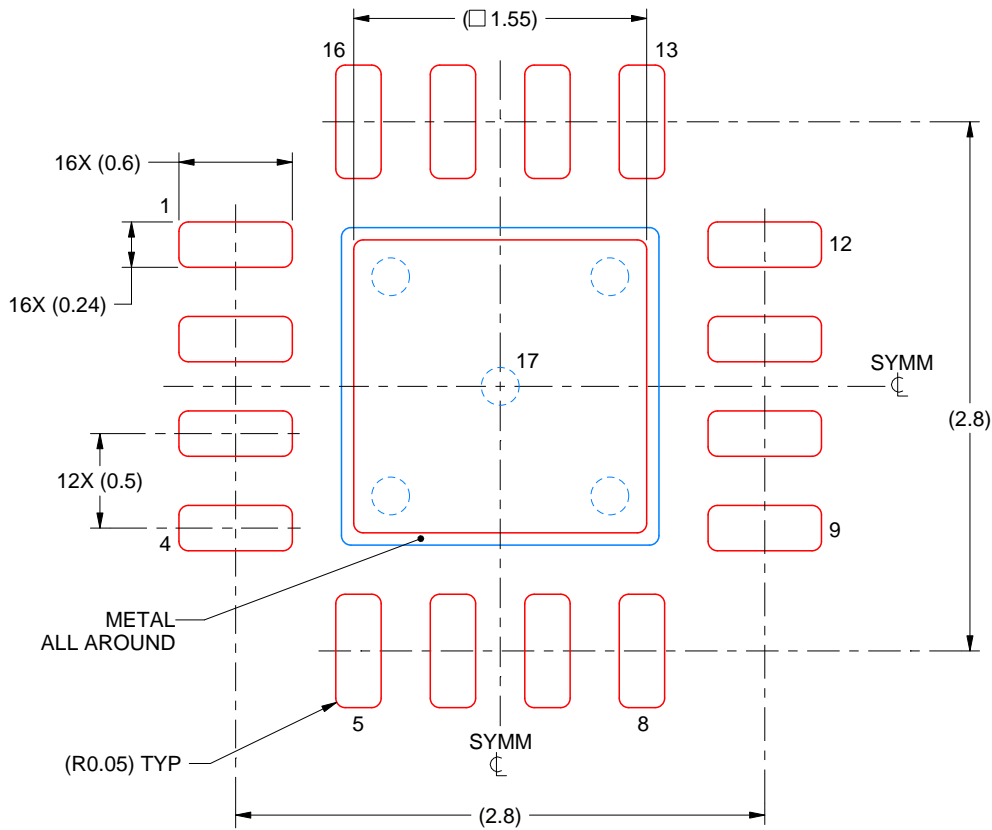

**SOLDER PASTE EXAMPLE**  
BASED ON 0.125 mm THICK STENCIL

EXPOSED PAD 17:  
85% PRINTED SOLDER COVERAGE BY AREA UNDER PACKAGE  
SCALE:25X

4222419/D 04/2022

NOTES: (continued)

6. Laser cutting apertures with trapezoidal walls and rounded corners may offer better paste release. IPC-7525 may have alternate design recommendations.

## IMPORTANT NOTICE AND DISCLAIMER

TI PROVIDES TECHNICAL AND RELIABILITY DATA (INCLUDING DATA SHEETS), DESIGN RESOURCES (INCLUDING REFERENCE DESIGNS), APPLICATION OR OTHER DESIGN ADVICE, WEB TOOLS, SAFETY INFORMATION, AND OTHER RESOURCES "AS IS" AND WITH ALL FAULTS, AND DISCLAIMS ALL WARRANTIES, EXPRESS AND IMPLIED, INCLUDING WITHOUT LIMITATION ANY IMPLIED WARRANTIES OF MERCHANTABILITY, FITNESS FOR A PARTICULAR PURPOSE OR NON-INFRINGEMENT OF THIRD PARTY INTELLECTUAL PROPERTY RIGHTS.

These resources are intended for skilled developers designing with TI products. You are solely responsible for (1) selecting the appropriate TI products for your application, (2) designing, validating and testing your application, and (3) ensuring your application meets applicable standards, and any other safety, security, regulatory or other requirements.

These resources are subject to change without notice. TI grants you permission to use these resources only for development of an application that uses the TI products described in the resource. Other reproduction and display of these resources is prohibited. No license is granted to any other TI intellectual property right or to any third party intellectual property right. TI disclaims responsibility for, and you will fully indemnify TI and its representatives against, any claims, damages, costs, losses, and liabilities arising out of your use of these resources.

TI's products are provided subject to [TI's Terms of Sale](#) or other applicable terms available either on [ti.com](https://www.ti.com) or provided in conjunction with such TI products. TI's provision of these resources does not expand or otherwise alter TI's applicable warranties or warranty disclaimers for TI products.

TI objects to and rejects any additional or different terms you may have proposed.

Mailing Address: Texas Instruments, Post Office Box 655303, Dallas, Texas 75265  
Copyright © 2023, Texas Instruments Incorporated

## Looking for pricing, stock, or lifecycle information?

Click below to explore more details on WIN SOURCE:

 [View TPA6139A2RGTT](#) on WIN SOURCE

 [Texas Instruments](#) Information

## Optimize Your Supply Chain with WIN SOURCE Solutions

-  Global Sourcing Solution
-  Obsolete Management
-  Cost Control Management
-  Shortage Management
-  Alternative Solution
-  Excess Inventory Management