



**THE DATASHEET OF
TPA2080D1YZGT**



TPA2080D1 2.2-W Constant Output Power Class-D Audio Amplifier With Class-G Boost Converter

1 Features

- 2.2 W into 4-Ω Load from 3.6-V Supply (1% THD+N)
- Integrated Class-G Boost Converter
 - Increases Efficiency at Low Output Power
- Low Quiescent Current of 3.5 mA from 3.6 V
- Thermal and Short-Circuit Protection With Auto Recovery
- 20-dB Fixed Gain
- Available in 1.53-mm × 1.98-mm, 0.5-mm pitch 12-ball WCSP (DSBGA) Package

2 Applications

- Cell Phones
- PDA, GPS
- Portable Electronics and Speakers

3 Description

The TPA2080D1 device is a high-efficiency Class-D audio power amplifier with an integrated Class-G boost converter that enhances efficiency at low output power. It drives up to 2.2 W into an 4-Ω speaker (1% THD+N). With 85% typical efficiency, the TPA2080D1 helps extend battery life when playing audio.

The built-in boost converter generates a 5.75-V supply voltage for the Class-D amplifier when high output power is required. This provides a louder audio output than a stand-alone amplifier directly connected to the battery. During low audio output power periods, the boost converter deactivates and connects VBAT directly to the Class-D amplifier supply, PVDD. This improves overall efficiency.

The TPA2080D1 has an integrated low-pass filter to improve the RF rejection and reduce DAC out-of-band noise, increasing the signal-to-noise ratio (SNR).

The TPA2080D1 is available in a space-saving 1.53-mm × 1.982-mm, 0.5-mm pitch WCSP package (YZG).

Device Information⁽¹⁾

| PART NUMBER | PACKAGE | BODY SIZE (NOM) |
|-------------|------------|-------------------|
| TPA2080D1 | DSBGA (12) | 1.53 mm × 1.98 mm |

(1) For all available packages, see the orderable addendum at the end of the data sheet.

Simplified Application Diagram

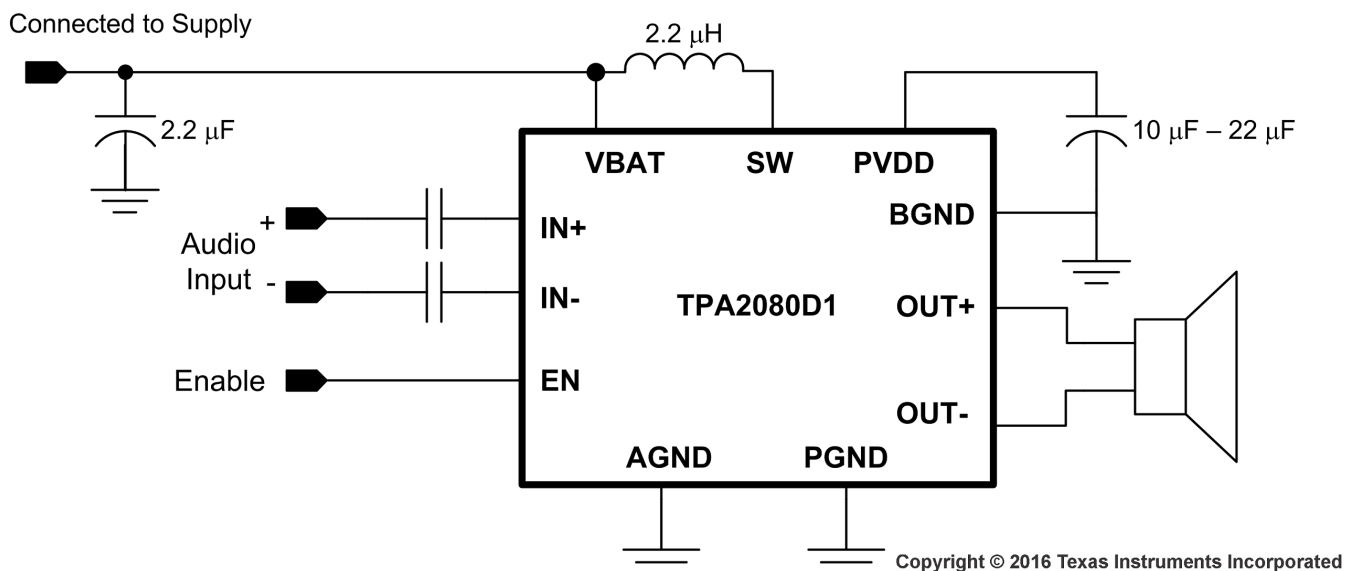

Table of Contents

| | | | |
|--|-----------|--|-----------|
| 1 Features | 1 | 9.3 Feature Description | 11 |
| 2 Applications | 1 | 9.4 Device Functional Modes | 14 |
| 3 Description | 1 | 10 Application and Implementation | 15 |
| 4 Revision History | 2 | 10.1 Application Information | 15 |
| 5 Device Comparison Table | 3 | 10.2 Typical Application | 15 |
| 6 Pin Configuration and Functions | 4 | 11 Power Supply Recommendations | 19 |
| 7 Specifications | 4 | 11.1 Power Supply Decoupling Capacitors | 19 |
| 7.1 Absolute Maximum Ratings | 4 | 12 Layout | 19 |
| 7.2 ESD Ratings | 5 | 12.1 Layout Guidelines | 19 |
| 7.3 Recommended Operating Conditions | 5 | 12.2 Layout Example | 21 |
| 7.4 Thermal Information | 5 | 13 Device and Documentation Support | 22 |
| 7.5 Electrical Characteristics | 5 | 13.1 Device Support | 22 |
| 7.6 Operating Characteristics | 6 | 13.2 Community Resources | 22 |
| 7.7 Typical Characteristics | 7 | 13.3 Trademarks | 22 |
| 8 Parameter Measurement Information | 10 | 13.4 Electrostatic Discharge Caution | 22 |
| 9 Detailed Description | 11 | 13.5 Glossary | 22 |
| 9.1 Overview | 11 | 14 Mechanical, Packaging, and Orderable Information | 23 |
| 9.2 Functional Block Diagram | 11 | 14.1 Package Dimensions | 23 |

4 Revision History

NOTE: Page numbers for previous revisions may differ from page numbers in the current version.

| Changes from Revision A (October 2012) to Revision B | Page |
|--|-------------|
| • Added <i>ESD Ratings</i> table, <i>Feature Description</i> section, <i>Device Functional Modes</i> , <i>Application and Implementation</i> section, <i>Power Supply Recommendations</i> section, <i>Layout</i> section, <i>Device and Documentation Support</i> section, and <i>Mechanical, Packaging, and Orderable Information</i> section. | 1 |
| • Removed <i>Ordering Information</i> table | 1 |

| Changes from Original (January 2012) to Revision A | Page |
|---|-------------|
| • Added (DSBGA) to the Packaged Devices of the ORDERING INFORMATION table | 1 |
| • Changed Feature From: Available in 1.53-mm × 1.98-mm, 0.5-mm pitch 12-ball WCSP Package To: Available in 1.53-mm × 1.98-mm, 0.5-mm pitch 12-ball WCSP (DSBGA) Package | 1 |

5 Device Comparison Table

| DEVICE NUMBER | SPEAKER AMP TYPE | SPECIAL FEATURES | OUTPUT POWER (W) | PSRR (dB) |
|---------------|------------------|--------------------------|------------------|-----------|
| TPA2013D1 | Class D | Boost Converter | 2.7 | 95 |
| TPA2015D1 | Class D | Adaptive Boost Converter | 2 | 85 |
| TPA2025D1 | Class D | Class G Boost Converter | 2 | 65 |
| TPA2080D1 | Class D | Class G Boost Converter | 2.2 | 62.5 |

6 Pin Configuration and Functions

YZG Package
12-Pin DSBGA
Top View

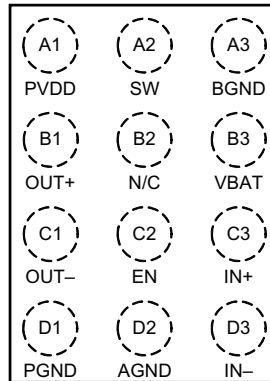

Pin Functions

| PIN | | TYPE | DESCRIPTION |
|------|-----|------|---|
| NAME | NO. | | |
| PVDD | A1 | O | Boost converter output and Class-D power stage supply voltage. |
| SW | A2 | I | Boost converter switch input; connect boost inductor between VBAT and SW. |
| BGND | A3 | P | Boost converter power ground. |
| OUT+ | B1 | O | Positive audio output. |
| N/C | B2 | – | No Connection |
| VBAT | B3 | P | Supply voltage. |
| OUT– | C1 | O | Negative audio output. |
| EN | C2 | I | Device enable; set to logic high to enable. |
| IN+ | C3 | I | Positive audio input. |
| PGND | D1 | P | Class-D power ground. |
| AGND | D2 | P | Analog ground. |
| IN– | D3 | I | Negative audio input. |

7 Specifications

7.1 Absolute Maximum Ratings

Over operating free-air temperature range, $T_A = 25^\circ\text{C}$ (unless otherwise noted)⁽¹⁾

| | | MIN | MAX | UNIT |
|---|----------|---|------------|------------------|
| Supply voltage | VBAT | –0.3 | 6 | V |
| Input voltage, V_I | IN+, IN– | –0.3 | VBAT + 0.3 | V |
| Minimum load resistance | | 3.2 | | Ω |
| Output continuous total power dissipation | | See Thermal Information | | |
| Operating free-air temperature, T_A | | –40 | 85 | $^\circ\text{C}$ |
| Operating junction temperature, T_J | | –40 | 150 | $^\circ\text{C}$ |
| Storage temperature, T_{stg} | | –65 | 150 | $^\circ\text{C}$ |

(1) Stresses beyond those listed under *Absolute Maximum Ratings* may cause permanent damage to the device. These are stress ratings only, and functional operation of the device at these or any other conditions beyond those indicated under *Recommended Operating Conditions* is not implied. Exposure to absolute-maximum-rated conditions for extended periods may affect device reliability.

7.2 ESD Ratings

| | | VALUE | UNIT |
|--------------------|-------------------------|--|-------|
| V _(ESD) | Electrostatic discharge | Human-body model (HBM), per ANSI/ESDA/JEDEC JS-001 ⁽¹⁾ | ±2000 |
| | | Charged-device model (CDM), per JEDEC specification JESD22-C101 ⁽²⁾ | ±500 |
| | | Machine model (MM) | ±100 |

(1) JEDEC document JEP155 states that 500-V HBM allows safe manufacturing with a standard ESD control process.

(2) JEDEC document JEP157 states that 250-V CDM allows safe manufacturing with a standard ESD control process.

7.3 Recommended Operating Conditions

| | | MIN | MAX | UNIT |
|-----------------|----------------------------------|-----|-----|------|
| | Supply voltage, V _{BAT} | 2.5 | 5.2 | V |
| V _{IH} | High-level input voltage, END | 1.3 | | V |
| V _{IL} | Low-level input voltage, END | | 0.6 | V |
| T _A | Operating free-air temperature | –40 | 85 | °C |
| T _J | Operating junction temperature | –40 | 150 | °C |

7.4 Thermal Information

| THERMAL METRIC ⁽¹⁾ | | TPA2080D1 | UNIT |
|-------------------------------|--|-------------|------|
| | | YZG (DSBGA) | |
| | | 12 PINS | |
| R _{θJA} | Junction-to-ambient thermal resistance | 97.3 | °C/W |
| R _{θJC(top)} | Junction-to-case (top) thermal resistance | 36.7 | °C/W |
| R _{θJB} | Junction-to-board thermal resistance | 55.9 | °C/W |
| Ψ _{JT} | Junction-to-top characterization parameter | 13.9 | °C/W |
| Ψ _{JB} | Junction-to-board characterization parameter | 49.5 | °C/W |
| R _{θJC(bot)} | Junction-to-case (bottom) thermal resistance | — | °C/W |

(1) For more information about traditional and new thermal metrics, see the *Semiconductor and IC Package Thermal Metrics* application report, [SPRA953](#).

7.5 Electrical Characteristics

V_{BAT} = 3.6 V, T_A = 25°C, R_L = 8 Ω + 33 μH (unless otherwise noted)

| PARAMETER | TEST CONDITIONS | MIN | TYP | MAX | UNIT |
|---------------------------------------|--|-----|------|-----|------|
| V _{BAT} supply voltage range | | 2.5 | | 5.2 | V |
| Class-D supply voltage range | EN = V _{BAT} , boost converter active | | 5.75 | | V |
| | Boost converter disabled (in bypass mode) | 2.5 | | 5.2 | |
| Supply under voltage shutdown | | | 2.2 | | V |
| Operating quiescent current | EN = V _{BAT} = 3.6 V | | 2 | 6 | mA |
| Shutdown quiescent current | V _{BAT} = 2.5 V to 5.2 V, EN = GND | | 0.2 | 1 | μA |
| Input common-mode voltage range | IN+, IN– | 0.6 | | 1.3 | V |
| Start-up time | | | 6 | 10 | ms |

7.6 Operating Characteristics

 V_{BAT} = 3.6 V, EN = V_{BAT}, T_A = 25°C, R_L = 8 Ω + 33 μH (unless otherwise noted)

| PARAMETER | | TEST CONDITIONS | MIN | TYP | MAX | UNIT |
|--------------------------|---|--|------|-------|------|-------------------|
| BOOST CONVERTER | | | | | | |
| PVDD | Boost converter output voltage range | I _{BOOST} = 0 mA | 5.4 | 5.75 | 6.4 | V |
| | | I _{BOOST} = 700 mA | | 5.6 | | |
| I _L | Boost converter input current limit | Power supply current | | 1800 | | mA |
| | Boost converter start-up current limit | Boost converter starts up from full shutdown | | 600 | | |
| | | Boost converter wakes up from auto-pass through mode | | 1000 | | |
| f _{BOOST} | Boost converter frequency | | | 1.2 | | MHz |
| CLASS-D AMPLIFIER | | | | | | |
| P _O | Output power | THD = 1%, V _{BAT} = 2.5 V, f = 1 kHz | | 1440 | | mW |
| | | THD = 1%, V _{BAT} = 3 V, f = 1 kHz | | 1750 | | |
| | | THD = 1%, V _{BAT} = 3.6 V, f = 1 kHz | | 1900 | | |
| | | THD = 1%, V _{BAT} = 2.5 V, f = 1 kHz, R _L = 4 Ω + 33 μH | | 1460 | | |
| | | THD = 1%, V _{BAT} = 3 V, f = 1 kHz, R _L = 4 Ω + 33 μH | | 1800 | | |
| | | THD = 1%, V _{BAT} = 3.6 V, f = 1 kHz, R _L = 4 Ω + 33 μH | | 2280 | | |
| A _V | Voltage gain | | 19.5 | 20 | 20.5 | dB |
| V _{OOS} | Output offset voltage | | | 2 | 10 | mV |
| | Short-circuit protection threshold current | | | 2 | | A |
| R _{IN} | Input impedance (per input pin) | | | 24 | | kΩ |
| | Input impedance in shutdown (per input pin) | EN = 0 V | | 1300 | | |
| Z _O | Output impedance in shutdown | | | 2 | | kΩ |
| | Maximum input voltage swing | EN = 0 V | | 2 | | V _{RMS} |
| | Boost converter auto-pass through threshold | Class-D output voltage threshold when boost converter automatically turns on | | 2 | | V _{PK} |
| f _{CLASS-D} | Class-D switching frequency | | 275 | 300 | 325 | kHz |
| η | Class-D and boost combined efficiency | P _O = 500 mW, V _{BAT} = 3.6 V | | 90% | | |
| E _N | Noise output voltage | A-weighted | | 49 | | μV _{RMS} |
| | | Unweighted | | 65 | | |
| SNR | Signal-to-noise ratio | 1.7 W, R _L = 8 Ω + 33 μH. A-weighted | | 97.5 | | dB |
| | | 1.7 W, R _L = 8 Ω + 33 μH. Unweighted | | 95 | | |
| | | 2 W, R _L = 4 Ω + 33 μH. A-weighted | | 95 | | |
| | | 2 W, R _L = 4 Ω + 33 μH. Unweighted | | 93 | | |
| THD+N | Total harmonic distortion plus noise ⁽¹⁾ | P _O = 100 mW, f = 1 kHz | | 0.06% | | |
| | | P _O = 500 mW, f = 1 kHz | | 0.07% | | |
| | | P _O = 1.7 W, f = 1 kHz, R _L = 8 Ω + 33 μH | | 0.07% | | |
| | | P _O = 2 W, f = 1 kHz, R _L = 4 Ω + 33 μH | | 0.15% | | |
| AC PSRR | AC-Power supply ripple rejection (output referred) | 200 mV _{PP} square ripple, V _{BAT} = 3.8 V, f = 217 Hz | | 62.5 | | dB |
| | | 200 mV _{PP} square ripple, V _{BAT} = 3.8 V, f = 1 kHz | | 62.5 | | |
| AC CMRR | AC-Common mode rejection ratio (output referred) | 200 mV _{PP} square ripple, V _{BAT} = 3.8 V, f = 217 Hz | | 71 | | dB |
| | | 200 mV _{PP} square ripple, V _{BAT} = 3.8 V, f = 1 kHz | | 71 | | |

(1) A-weighted

7.7 Typical Characteristics

$V_{BAT} = 3.6\text{ V}$, $C_1 = 1\ \mu\text{F}$, $C_{BOOST} = 22\ \mu\text{F}$, $L_{BOOST} = 2.2\ \mu\text{H}$, $EN = V_{BAT}$, and Load = $8\ \Omega + 33\ \mu\text{H}$, no ferrite bead unless otherwise specified.

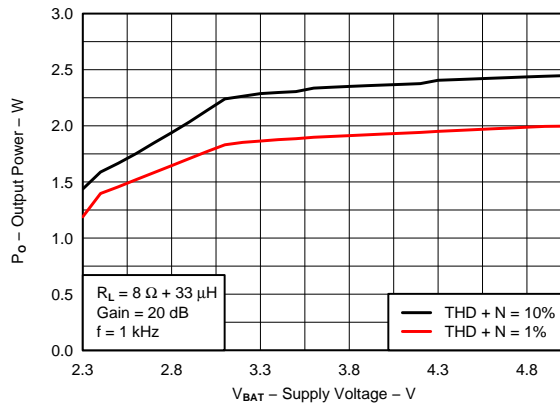

Figure 1. Output Power vs Supply Voltage

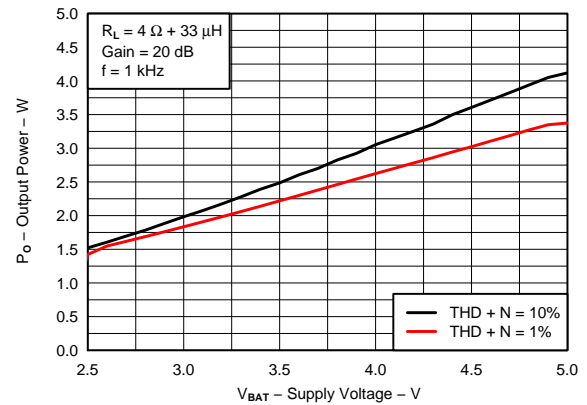

Figure 2. Output Power vs Supply Voltage

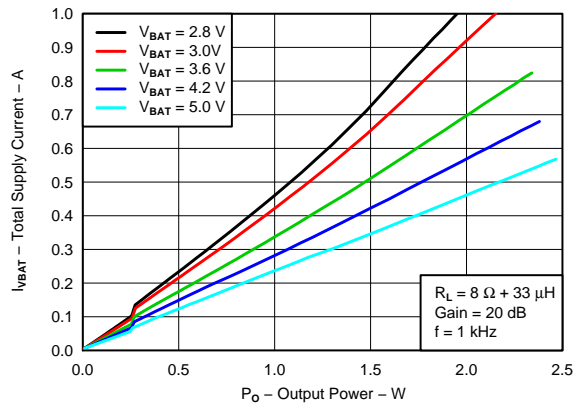

Figure 3. Total Supply Current vs Output Power

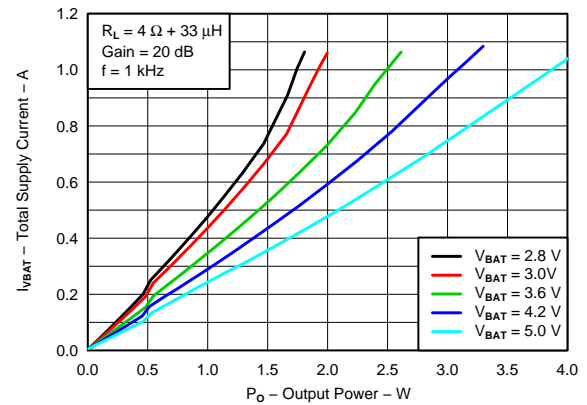

Figure 4. Total Supply Current vs Output Power

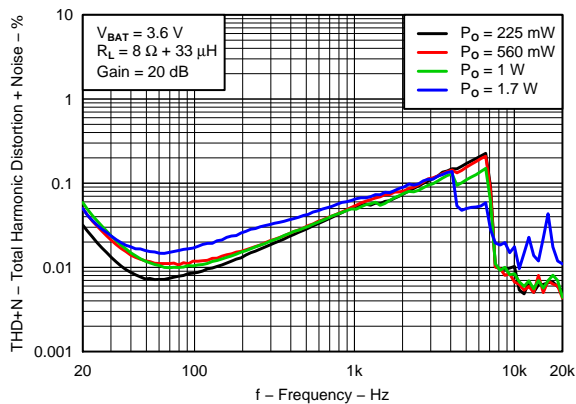

Figure 5. THD+N vs Frequency

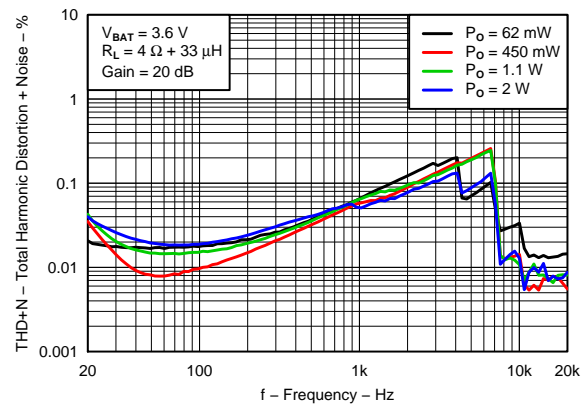
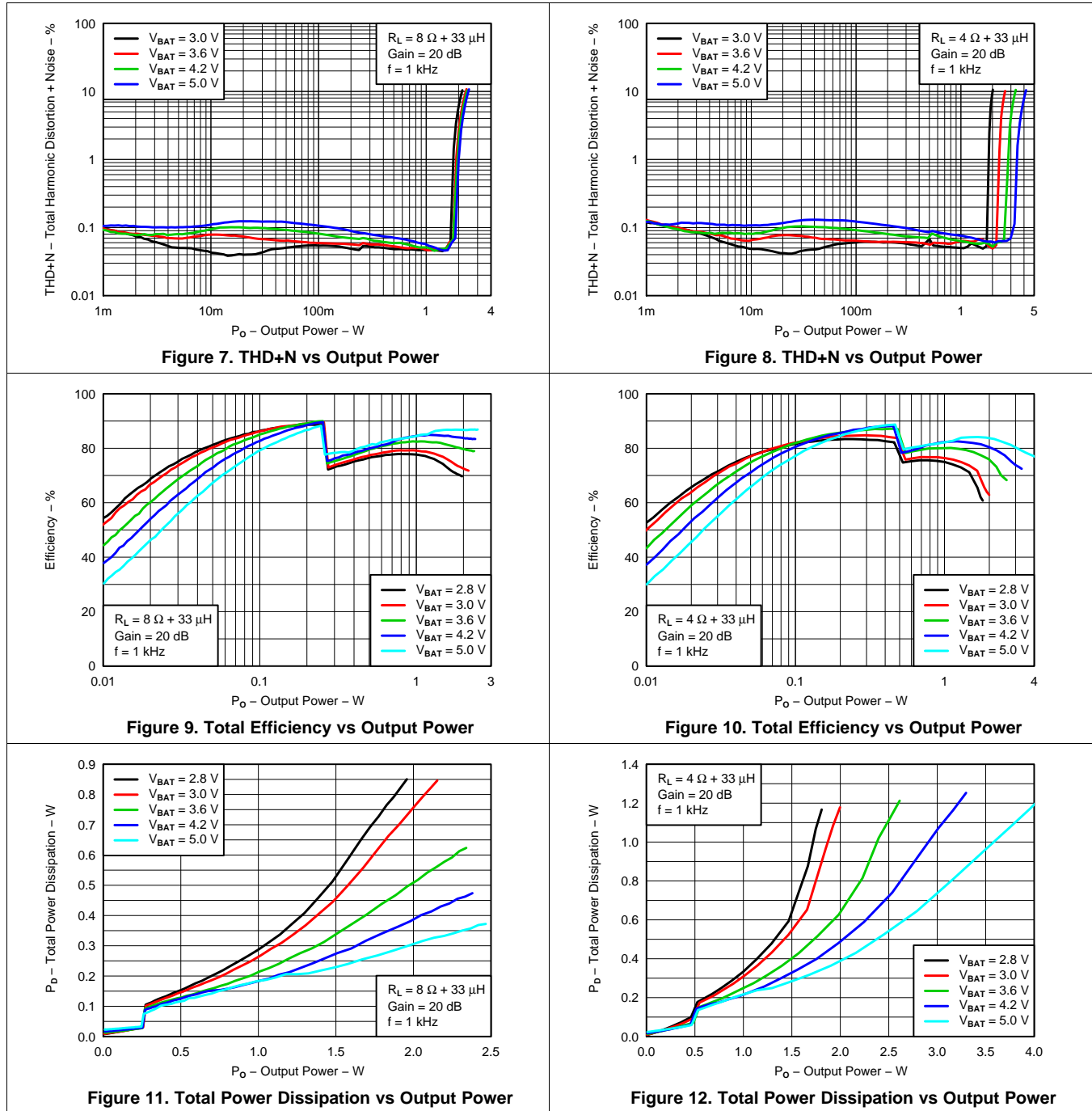

Figure 6. THD+N vs Frequency

Typical Characteristics (continued)

$V_{BAT} = 3.6\text{ V}$, $C_1 = 1\ \mu\text{F}$, $C_{BOOST} = 22\ \mu\text{F}$, $L_{BOOST} = 2.2\ \mu\text{H}$, $EN = V_{BAT}$, and Load = $8\ \Omega + 33\ \mu\text{H}$, no ferrite bead unless otherwise specified.



Typical Characteristics (continued)

$V_{BAT} = 3.6\text{ V}$, $C_1 = 1\ \mu\text{F}$, $C_{BOOST} = 22\ \mu\text{F}$, $L_{BOOST} = 2.2\ \mu\text{H}$, $EN = V_{BAT}$, and Load = $8\ \Omega + 33\ \mu\text{H}$, no ferrite bead unless otherwise specified.

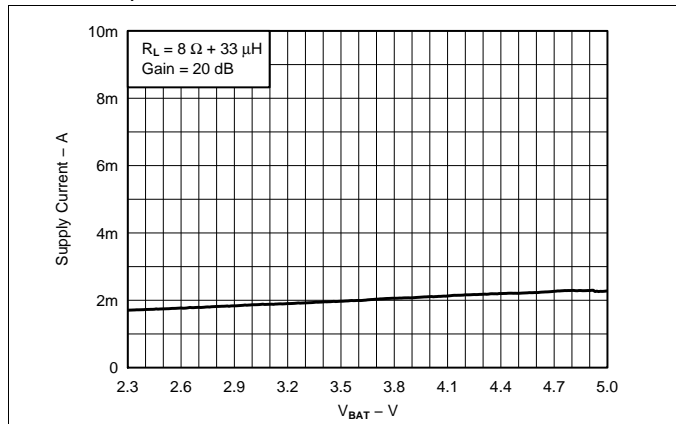

Figure 13. Quiescent Supply Current vs Battery Voltage

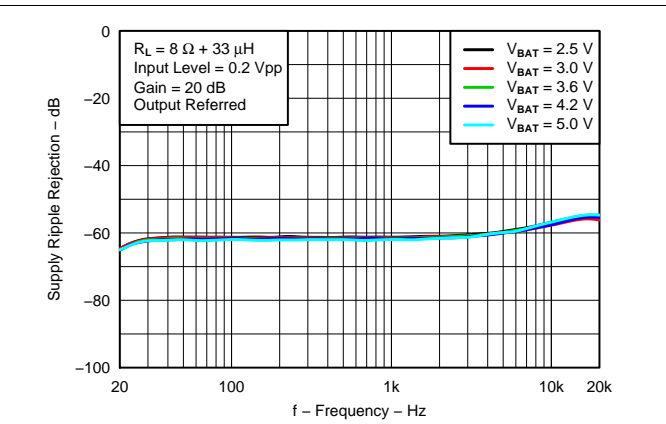

Figure 14. Supply Ripple Rejection vs Frequency

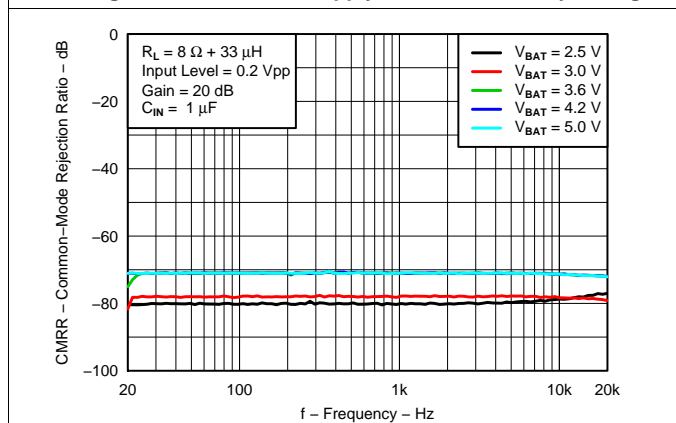

Figure 15. Common-Mode Rejection Ratio vs Frequency

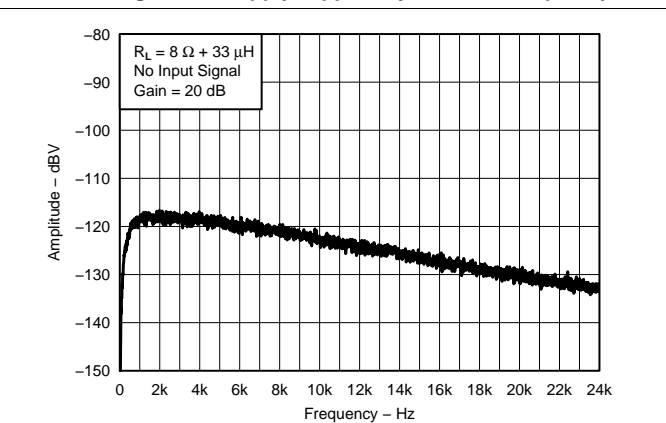

Figure 16. A-Weighted Output Noise vs Frequency

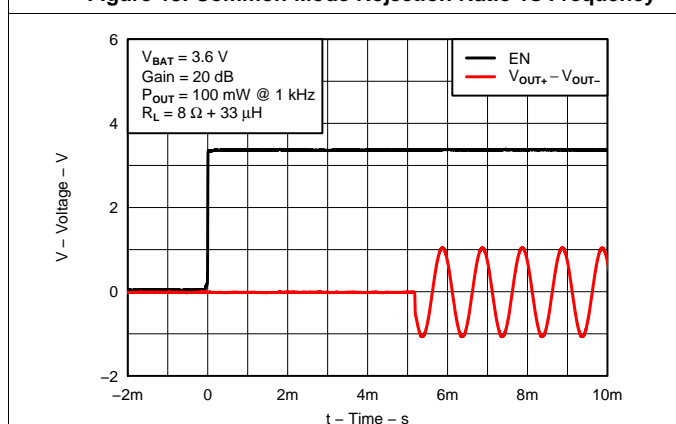

Figure 17. Start-Up timing

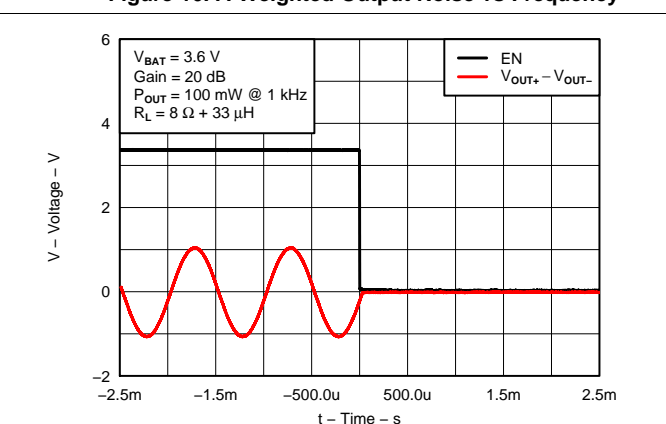

Figure 18. Shutdown timing

Typical Characteristics (continued)

VBAT = 3.6 V, C₁ = 1 μF, C_{BOOST} = 22 μF, L_{BOOST} = 2.2 μH, EN = VBAT, and Load = 8 Ω + 33 μH, no ferrite bead unless otherwise specified.

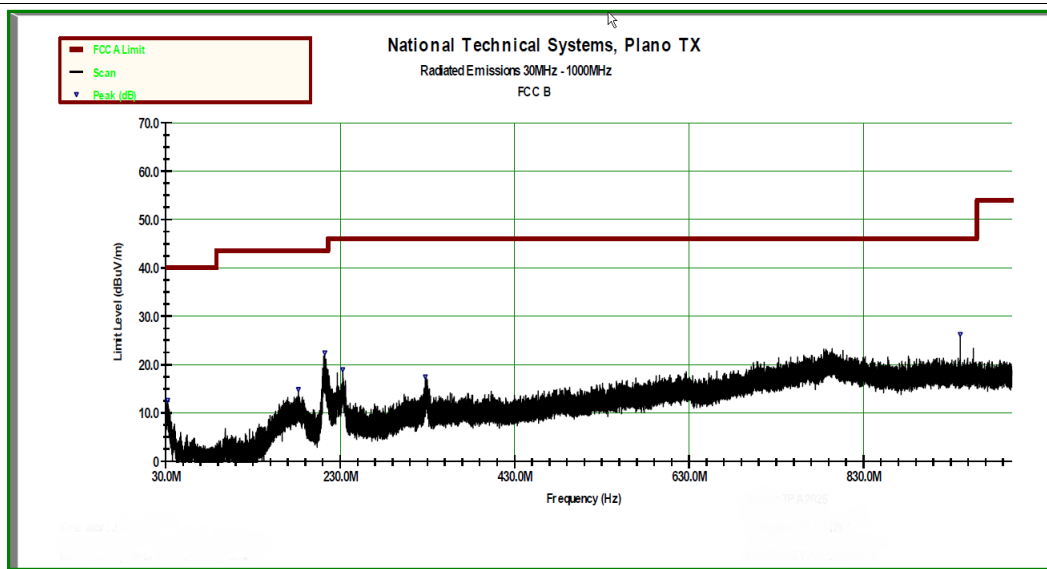
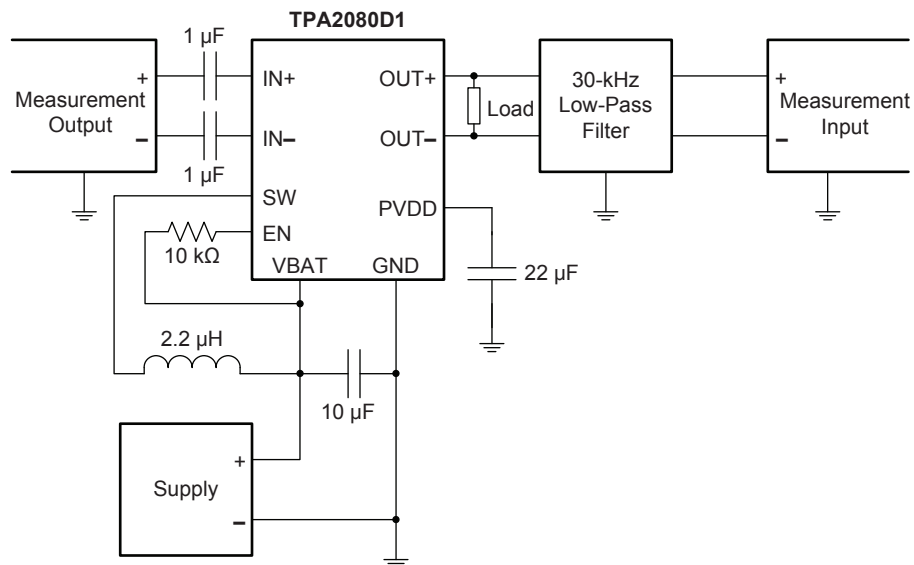

Figure 19. EMC Performance P_O = 750 mW With 2-Inch Speaker Cable

8 Parameter Measurement Information

All parameters are measured according to the conditions described in [Specifications](#).



- (1) The 1-μF input capacitors on IN+ and IN- were shorted for input common-mode voltage measurements.
- (2) A 33-μH inductor was placed in series with the load resistor to emulate a small speaker for efficiency measurements.
- (3) The 30-kHz low-pass filter is required even if the analyzer has an internal low-pass filter. An R-C low-pass filter (100 Ω, 47 nF) is used on each output for the data sheet graphs.

Figure 20. Test Setup for Graphs

9 Detailed Description

9.1 Overview

The TPA2080D1 is a high-efficiency Class-D audio power amplifier with an integrated Class-G boost converter that enhances efficiency at low output power. The built-in converter generates a 5.75-V supply voltage for the Class-D amplifier when high output power is required. The device has an integrated low-pass filter to improve the RF rejection and reduce DAC out-of-band noise, increasing the signal-to-noise ratio (SNR).

9.2 Functional Block Diagram

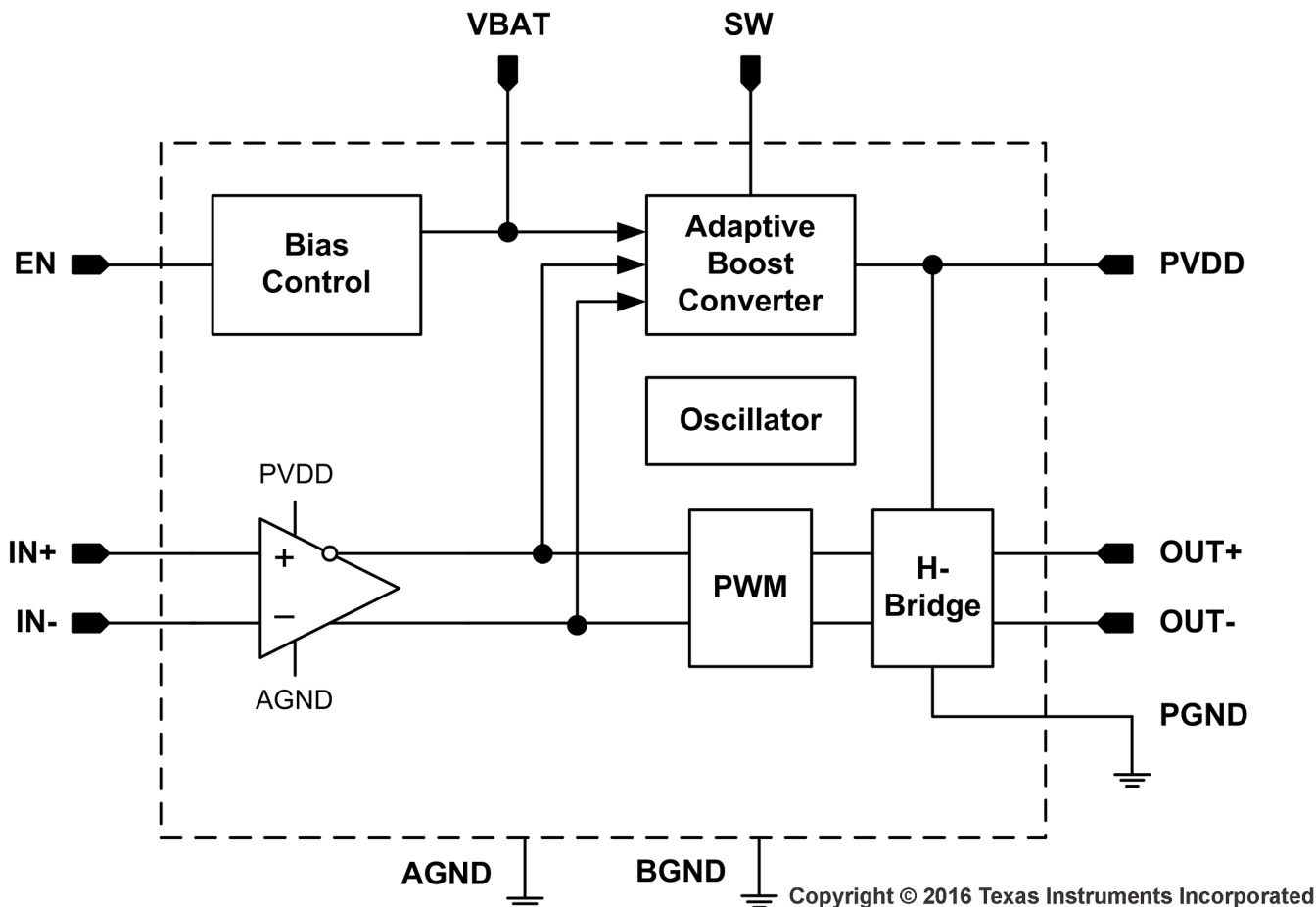

9.3 Feature Description

9.3.1 Fully Differential Amplifier

The TPA2080D1 is a fully differential amplifier with differential inputs and outputs. The fully differential amplifier consists of a differential amplifier with common-mode feedback. The differential amplifier ensures that the amplifier outputs a differential voltage on the output that is equal to the differential input times the gain. The common-mode feedback ensures that the common-mode voltage at the output is biased around $V_{CC}/2$ regardless of the common-mode voltage at the input. The fully differential TPA2080D1 can still be used with a single-ended input; however, the TPA2080D1 must be used with differential inputs when in a noisy environment, like a wireless handset, to ensure maximum noise rejection.

9.3.1.1 Advantages of Fully Differential Amplifiers

- Input-coupling capacitors not required:
 - The fully differential amplifier allows the inputs to be biased at voltage other than mid-supply. The inputs of

Feature Description (continued)

the TPA2080D1 can be biased anywhere within the common-mode input voltage range listed in [Recommended Operating Conditions](#) and [Electrical Characteristics](#). If the inputs are biased outside of that range, input-coupling capacitors are required.

- Midsupply bypass capacitor, $C_{(BYPASS)}$, not required:
 - The fully differential amplifier does not require a bypass capacitor. Any shift in the midsupply affects both positive and negative channels equally and cancels at the differential output.
- Better RF-immunity:
 - GSM handsets save power by turning on and shutting off the RF transmitter at a rate of 217 Hz. The transmitted signal is picked up on input and output traces. The fully differential amplifier cancels the signal better than the typical audio amplifier.

9.3.2 Short-Circuit Auto-Recovery

When a short-circuit event happens, the TPA2080D1 goes to low duty cycle mode and tries to reactivate itself every 1.6 seconds. The auto-recovery will continue until the short-circuit event stops. This feature protects the device without affecting the long-term reliability of the device.

9.3.3 Operation With DACs and CODECs

Large noise voltages can be present at the output of $\Delta\Sigma$ DACs and CODECs, just above the audio frequency (for example, 80 kHz with a 300 mV_{p-p}). This out-of-band noise is due to the noise shaping of the delta-sigma modulator in the DAC. Some Class-D amplifiers have higher output noise when used in combination with these DACs and CODECs. This is because out-of-band noise from the CODEC/DAC mixes with the Class-D switching frequencies in the audio amplifier input stage. The TPA2080D1 has a built-in low-pass filter with cutoff frequency at 55 kHz that reduces the out-of-band noise and RF noise, filtering out-of-band frequencies that could degrade in-band noise performance. If driving the TPA2080D1 input with 4th-order or higher $\Delta\Sigma$ DACs or CODECs, add an R-C low pass filter at each of the audio inputs (IN+ and IN–) of the TPA2080D1 to ensure best performance. The recommended resistor value is 100 Ω and the capacitor value of 47 nF.

9.3.4 Speaker Load Limitation

Speakers are nonlinear loads with varying impedance (magnitude and phase) over the audio frequency. A portion of speaker load current can flow back into the boost converter output through the Class-D output H-bridge high-side device. This is dependent on the phase change over frequency on the speaker, and the audio signal amplitude and frequency content. Most portable speakers have limited phase change at the resonant frequency, typically no more than 40 or 50 degrees. To avoid excess flow-back current, use speakers with limited phase change. Otherwise, flow-back current could drive the PVDD voltage above the absolute maximum recommended operational voltage.

Confirm proper operation by connecting the speaker to the TPA2080D1 and driving it at maximum output swing. Observe the PVDD voltage with an oscilloscope. In the unlikely event the PVDD voltage exceeds 6.5 V, add a 6.8-V Zener diode between PVDD and ground to ensure the TPA2080D1 operates properly. The amplifier has thermal overload protection and deactivates if the die temperature exceeds 150°C. It automatically reactivates once die temperature returns below 150°C. Built-in output overcurrent protection deactivates the amplifier if the speaker load becomes short-circuited. The amplifier automatically restarts 1.6 seconds after the overcurrent event. Although the TPA2080D1 Class-D output can withstand a short between OUT+ and OUT–, do not connect either output directly to GND, VDD, or VBAT as this could damage the device.

9.3.5 Filter-Free Operation and Ferrite Bead Filters.

A ferrite bead filter can often be used if the design is failing radiated emissions without an LC filter and the frequency sensitive circuit is greater than 1 MHz. This filter functions well for circuits that just have to pass FCC and CE because FCC and CE only test radiated emissions greater than 30 MHz. When choosing a ferrite bead, choose one with high impedance at high frequencies, and very low impedance at low frequencies. In addition, select a ferrite bead with adequate current rating to prevent distortion of the output signal.

Use an LC output filter if there are low-frequency, (< 1 MHz) EMI-sensitive circuits or long leads from amplifier to speaker.

[Figure 21](#) shows a typical ferrite bead output filters.

Feature Description (continued)

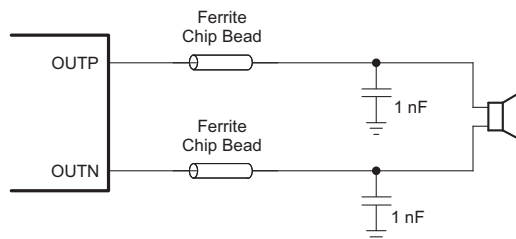

Figure 21. Typical Ferrite Chip Bead Filter

Table 1. Suggested Chip Ferrite Bead

| LOAD | VENDOR | PART NUMBER | SIZE |
|------|--------|---------------|------|
| 8 Ω | Murata | BLM18EG121SN1 | 0603 |
| 4 Ω | TDK | MPZ2012S101A | 0805 |

9.3.6 Boost Converter Auto Pass Through (APT)

The TPA2080D1 consists of a Class-G boost converter and a Class-D amplifier. The boost converter operates from the supply voltage, VBAT, and generates a higher output voltage PVDD at 5.75 V. PVDD drives the supply voltage of the Class-D amplifier. This improves loudness over non-boosted solutions. The boost converter has a *pass through* mode in which it turns off automatically and PVDD is directly connected to VBAT through an internal bypass switch.

The boost converter is adaptive and operates between pass through mode and boost mode depending on the output audio signal amplitude. When the audio output amplitude exceeds the *auto pass through* (APT) threshold, the boost converter is activated automatically and goes to boost mode. The transition time from normal mode to boost mode is fast enough to prevent clipping large transient audio signals. The APT threshold of the TPA2080D1 is fixed at 2 V_{PEAK}. When the audio output signal is below APT threshold, the boost converter is deactivated and goes to pass through mode. The adaptive boost converter maximizes system efficiency at lower audio output levels.

The Class-G boost converter is designed to drive the Class-D amplifier only. Do not use the boost converter to drive external devices.

Figure 22 shows how the adaptive boost converter behaves with a typical audio signal.

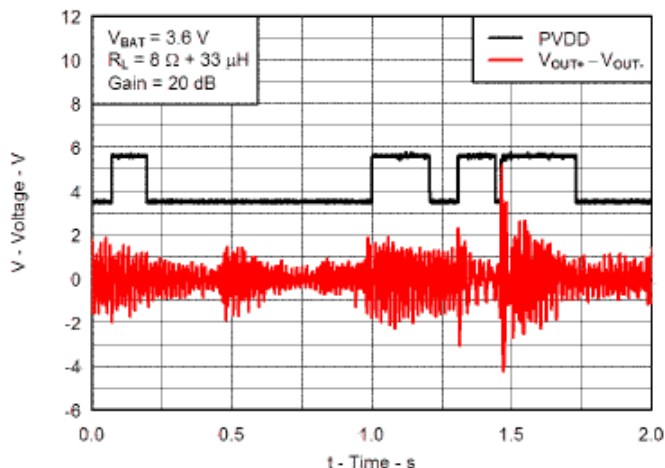

Figure 22. Class-G Boost Converter With Typical Music Playback

9.4 Device Functional Modes

9.4.1 Shutdown Mode

The TPA2080D1 can be put in shutdown mode when asserting EN to a logic LOW. While in shutdown mode, the device output stage is turned off and the current consumption is very low.

10 Application and Implementation

NOTE

Information in the following applications sections is not part of the TI component specification, and TI does not warrant its accuracy or completeness. TI's customers are responsible for determining suitability of components for their purposes. Customers should validate and test their design implementation to confirm system functionality.

10.1 Application Information

These typical connection diagrams highlight the required external components and system level connections for proper operation of the device. Each of these configurations can be realized using the Evaluation Modules (EVMs) for the device. These flexible modules allow full evaluation of the device in the most common modes of operation. Any design variation can be supported by TI through schematic and layout reviews. Visit e2e.ti.com for design assistance and join the audio amplifier discussion forum for additional information.

10.2 Typical Application

10.2.1 TPA2080D1 With Differential Input Signal

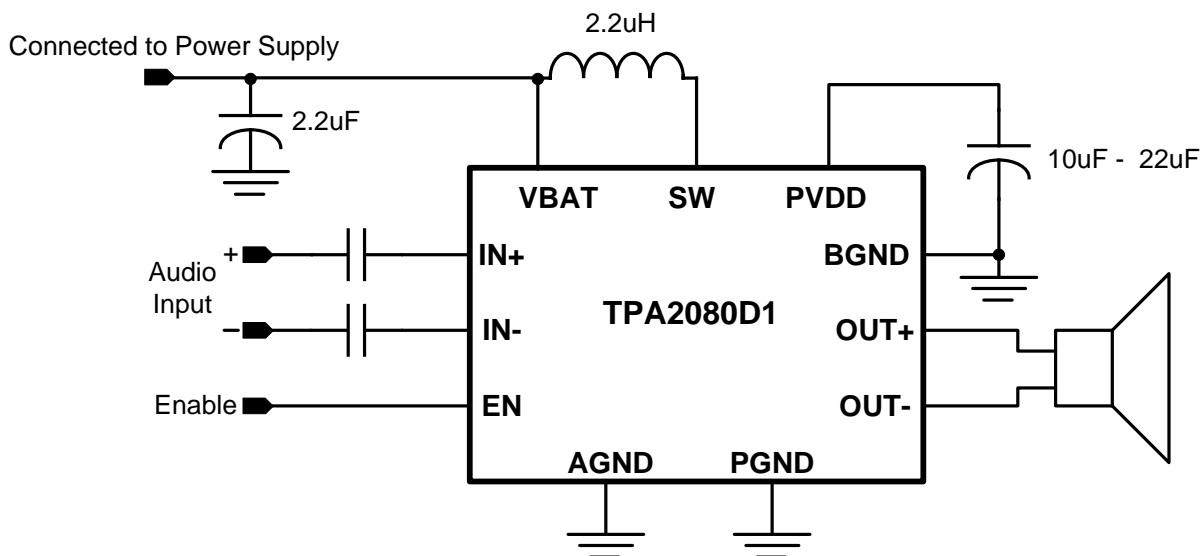

Copyright © 2016, Texas Instruments Incorporated

Figure 23. Typical Application Schematic With Differential Input Signals

10.2.1.1 Design Requirements

For this design example, use the parameters listed in [Table 2](#).

Table 2. Design Parameters

| DESIGN PARAMETER | EXAMPLE VALUE |
|------------------|---------------|
| Power supply | 3.6 V |
| Enable inputs | High > 1.3 V |
| | Low < 0.6 V |
| Speaker | 8 Ω |

10.2.1.2 Detailed Design Procedure

10.2.1.2.1 Surface Mount Inductor

Working inductance decreases as inductor current increases. If the drop in working inductance is severe enough, it may cause the boost converter to become unstable, or cause the TPA2080D1 to reach its current limit at a lower output power than expected. Inductor vendors specify currents at which inductor values decrease by a specific percentage. This can vary from 10% to 35%. Inductance is also affected by DC current and temperature.

10.2.1.2.2 Inductor Selection

Inductor current rating is determined by the requirements of the load. The inductance is determined by two factors: the minimum value required for stability and the maximum ripple current permitted in the application. Use Equation 1 to determine the required current rating. Equation 1 shows the approximate relationship between the average inductor current, I_L , to the load current, load voltage, and input voltage (I_{PVDD} , $PVDD$, and $VBAT$, respectively). Insert I_{PVDD} , $PVDD$, and $VBAT$ into Equation 1 and solve for I_L . The inductor must maintain at least 90% of its initial inductance value at this current.

$$I_L = I_{PVDD} \times \left(\frac{PVDD}{VBAT \times 0.8} \right) \tag{1}$$

Ripple current, ΔI_L , is peak-to-peak variation in inductor current. Smaller ripple current reduces core losses in the inductor and reduces the potential for EMI. Use Equation 2 to determine the value of the inductor, L . Equation 2 shows the relationship between inductance L , $VBAT$, $PVDD$, the switching frequency, f_{BOOST} , and ΔI_L . Insert the maximum acceptable ripple current into Equation 2 and solve for L .

$$L = \frac{VBAT \times (PVDD - VBAT)}{\Delta I_L \times f_{BOOST} \times PVDD} \tag{2}$$

ΔI_L is inversely proportional to L . Minimize ΔI_L as much as is necessary for a specific application. Increase the inductance to reduce the ripple current. Do not use greater than 4.7 μH , as this prevents the boost converter from responding to fast output current changes properly. If using above 3.3 μH , then use at least 10- μF capacitance on $PVDD$ to ensure boost converter stability.

The typical inductor value range for the TPA2080D1 is 2.2 μH to 3.3 μH . Select an inductor with less than 0.5- Ω DC resistance, DCR. Higher DCR reduces total efficiency due to an increase in voltage drop across the inductor.

Table 3. Sample Inductors

| L (μH) | SUPPLIER | COMPONENT CODE | SIZE (LxWxH mm) | DCR TYP (m Ω) | I _{SAT} MAX (A) | C RANGE |
|---------------|----------------------------|--------------------|-----------------|-----------------------|--------------------------|--|
| 2.2 | Chilisin Electronics Corp. | CLCN252012T-2R2M-N | 2.5 x 2 x 1.2 | 105 | 1.2 | 10 to 22 μF , 16 V 10 to 22 μF , 10 V |
| 2.2 | Toko | 1239AS-H-2R2N=P2 | 2.5 x 2 x 1.2 | 96 | 2.3 | |
| 2.2 | Coilcraft | XFL4020-222MEC | 4 x 4 x 2.15 | 22 | 3.5 | |
| 3.3 | Toko | 1239AS-H-3R3N=P2 | 2.5 x 2 x 1.2 | 160 | 2 | 10 to 22 μF , 10 V |
| 3.3 | Coilcraft | XFL4020-332MEC | 4 x 4 x 2.15 | 35 | 2.8 | |

10.2.1.2.3 Surface Mount Capacitors

Temperature and applied DC voltage influence the actual capacitance of high-K materials. Table 4 shows the relationship between the different types of high-K materials and their associated tolerances, temperature coefficients, and temperature ranges. Notice that a capacitor made with X5R material can lose up to 15% of its capacitance within its working temperature range.

In an application, the working capacitance of components made with high-K materials is generally much lower than nominal capacitance. A worst-case result with a typical X5R material might be -10% tolerance, -15% temperature effect, and -45% DC voltage effect at 50% of the rated voltage. This particular case would result in a working capacitance of 42% ($0.9 \times 0.85 \times 0.55$) of the nominal value.

Select high-K ceramic capacitors according to the following rules:

1. Use capacitors made of materials with temperature coefficients of X5R, X7R, or better.
2. Use capacitors with DC voltage ratings of at least twice the application voltage. Use minimum 10-V

capacitors for the TPA2080D1.

- Choose a capacitance value at least twice the nominal value calculated for the application. Multiply the nominal value by a factor of 2 for safety. If a 10- μF capacitor is required, use 20 μF .

The preceding rules and recommendations apply to capacitors used in connection with the TPA2080D1. The TPA2080D1 cannot meet its performance specifications if the rules and recommendations are not followed.

Table 4. Typical Tolerance and Temperature Coefficient of Capacitance by Material

| MATERIAL | COG / NPO | X7R | X5R |
|---------------------------------------|--|--|---|
| Typical tolerance | $\pm 5\%$ | $\pm 10\%$ | 80% or -20% |
| Temperature | ± 30 ppm | $\pm 15\%$ | 22% or -82% |
| Temperature range, $^{\circ}\text{C}$ | -55°C to 125°C | -55°C to 125°C | -30°C to 85°C |

10.2.1.2.4 Boost Converter Capacitor Selection

The value of the boost capacitor is determined by the minimum value of working capacitance required for stability and the maximum voltage ripple allowed on PVDD in the application. Working capacitance refers to the available capacitance after derating the capacitor value for DC bias, temperature, and aging. Do not use any component with a working capacitance less than 6.8 μF . This corresponds to a 10- μF , 16-V capacitor or a 10- μF , 10-V capacitor.

Do not use above 22- μF capacitance as it will reduce the boost converter response time to large output current transients.

[Equation 3](#) shows the relationship between the boost capacitance, C, to load current, load voltage, ripple voltage, input voltage, and switching frequency (I_{PVDD} , PVDD, ΔV , VBAT, and f_{BOOST} respectively).

Insert the maximum allowed ripple voltage into [Equation 3](#) and solve for C. The 1.5 multiplier accounts for capacitance loss due to applied DC voltage and temperature for X5R and X7R ceramic capacitors.

$$C = 1.5 \times \frac{I_{\text{PVDD}} \times (\text{PVDD} - \text{VBAT})}{\Delta V \times f_{\text{BOOST}} \times \text{PVDD}} \quad (3)$$

10.2.1.2.5 Decoupling Capacitors

The TPA2080D1 is a high-performance Class-D audio amplifier that requires adequate power supply decoupling. Adequate power supply decoupling to ensures that the efficiency is high and total harmonic distortion (THD) is low.

Place a low equivalent-series-resistance (ESR) ceramic capacitor, typically 0.1 μF , within 2 mm of the VBAT ball. Use X5R and X7R ceramic capacitors. This choice of capacitor and placement helps with higher frequency transients, spikes, or digital hash on the line. Additionally, placing this decoupling capacitor close to the TPA2080D1 is important, as any parasitic resistance or inductance between the device and the capacitor causes efficiency loss. In addition to the 0.1- μF ceramic capacitor, place a 2.2- μF to 10- μF capacitor on the VBAT supply trace. This larger capacitor acts as a charge reservoir, providing energy faster than the board supply, thus helping to prevent any droop in the supply voltage.

10.2.1.2.6 Input Capacitors

Input audio DC decoupling capacitors are recommended. The input capacitors and TPA2080D1 input impedance form a high-pass filter with the corner frequency, f_c , determined in [Equation 4](#).

Any mismatch in capacitance between the two inputs will cause a mismatch in the corner frequencies. Severe mismatch may also cause turnon pop noise. Choose capacitors with a tolerance of $\pm 10\%$ or better. Use X5R and X7R ceramic capacitors.

$$f_c = \frac{1}{(2 \times \pi \times R_i C_i)} \quad (4)$$

The value of the input capacitor is important to consider as it directly affects the bass (low frequency) performance of the circuit. Speakers in wireless phones cannot usually respond well to low frequencies, so the corner frequency can be set to block low frequencies in this application. Not using input capacitors can increase output offset.

10.2.1.2.7 Boost Converter Component Section

The critical external components are summarized in [Table 5](#).

Table 5. Recommended Values

| PARAMETER | TEST CONDITIONS | MIN | TYP | MAX | UNIT |
|----------------------------------|---|-----|-----|-----|------|
| Boost converter inductor | At 30% rated DC bias current of the inductor | 1.5 | 2.2 | 4.7 | μH |
| Input capacitor | | 1 | | 10 | μF |
| Boost converter output capacitor | Working capacitance biased at boost output voltage, if 4.7-μH inductor is chosen, then minimum capacitance is 10 μF | 4.7 | | 22 | μF |

10.2.1.3 Application Curves

For application curves, see the figures listed in [Table 6](#).

Table 6. Table of Graphs

| DESCRIPTION | FIGURE NUMBER |
|---|---------------------------|
| Output Power vs Supply Voltage | Figure 1 |
| THD+N vs Frequency | Figure 5 |
| THD+N vs Output Power | Figure 7 |
| Total Power Dissipation vs Output Power | Figure 11 |

10.2.2 TPA2080D1 With Single-Ended Signals.

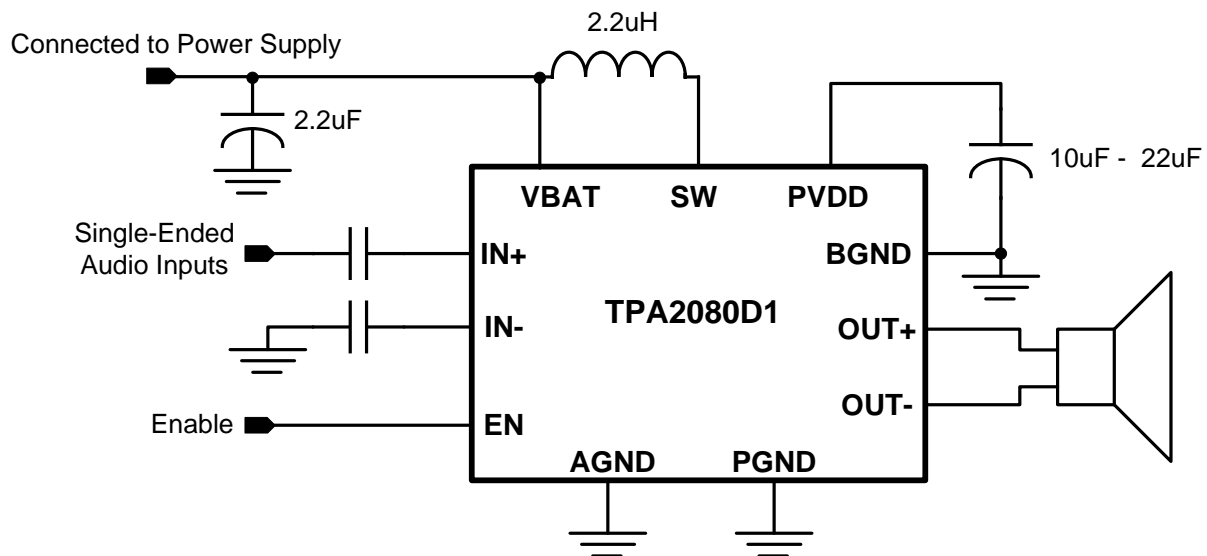

Figure 24. Typical Application Schematic With Single-Ended Input Signal

10.2.2.1 Design Requirements

For this design example, use the parameters listed in [Table 2](#).

10.2.2.2 Detailed Design Procedure

For the design procedure see [Detailed Design Procedure](#).

10.2.2.3 Application Curves

For application curves, see the figures listed in [Table 6](#).

11 Power Supply Recommendations

The TPA2080D1 is designed to operate from an input voltage supply range from 2.5 V to 5.2 V. Therefore the output voltage range of the power supply should be within this range. The current capability of upper power must not exceed the maximum current limit of the power switch.

11.1 Power Supply Decoupling Capacitors

The TPA2080D1 requires adequate power supply decoupling to ensure a high efficiency operation with low total harmonic distortion (THD). Place a low equivalent-series-resistance (ESR) ceramic capacitor, typically 0.1 μF , within 2 mm of the VBAT/PVDD pin. This choice of capacitor and placement helps with higher frequency transients, spikes, or digital hash on the line. In addition to the 0.1- μF ceramic capacitor, TI recommends placing a 2.2- μF to 10- μF capacitor on the VBAT supply trace. This larger capacitor acts as a charge reservoir, providing energy faster than the board supply, thus helping to prevent any droop in the supply voltage.

12 Layout

12.1 Layout Guidelines

12.1.1 Component Placement

Place all the external components close to the TPA2080D1 device. Placing the decoupling capacitors as close as possible to the device is important for the efficiency of the class-D amplifier. Any resistance or inductance in the trace between the device and the capacitor can cause a loss in efficiency.

12.1.2 Thermal Considerations

It is important to operate the TPA2080D1 at temperatures lower than its maximum operating temperature. The maximum ambient temperature depends on the heat-sinking ability of the PCB system. Given θ_{JA} of 97.3°C/W, the maximum allowable junction temperature of 150°C, and the internal dissipation of 0.5 W for 1.9-W, 8 Ω -load, 3.6-V supply, the maximum ambient temperature is calculated as:

$$T_{A,MAX} = T_{J,MAX} - \theta_{JA}P_D = 150^\circ\text{C} - (97.3^\circ\text{C/W} \times 0.5 \text{ W}) = 101.4^\circ\text{C} \quad (5)$$

The calculated maximum ambient temperature is 101.4°C at maximum power dissipation at 3.6-V supply and 8- Ω load. The TPA2080D1 is designed with thermal protection that turns the device off when the junction temperature surpasses 150°C to prevent damage to the IC.

12.1.3 Pad Size

TPA2080D1 has AGND, BGND and PGND for analog circuit, boost converter and Class-D amplifier respectively. These three ground pins should be connected together through a solid ground plane with multiple ground VIAs.

In making the pad size for the WCSP balls, it is recommended that the layout use non-solder mask defined (NSMD) land. With this method, the solder mask opening is made larger than the desired land area, and the opening size is defined by the copper pad width. [Figure 25](#) shows the appropriate diameters for a WCSP layout.

Layout Guidelines (continued)

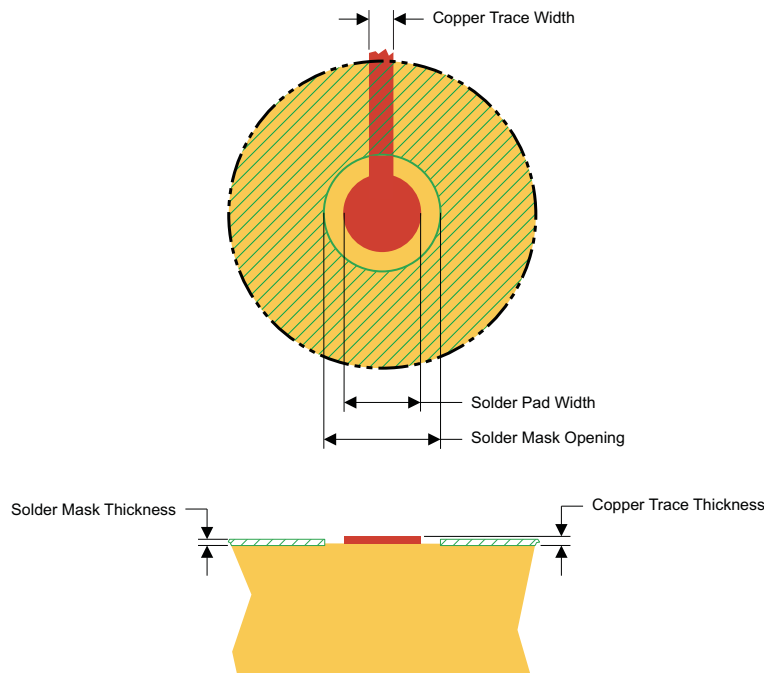

M0200-01

Figure 25. Land Pattern Dimensions

Table 7. Land Pattern Dimensions^{(1) (2) (3) (4)}

| SOLDER PAD DEFINITIONS | COPPER PAD | SOLDER MASK ⁽⁵⁾ OPENING | COPPER THICKNESS | STENCIL ^{(6) (7)} OPENING | STENCIL THICKNESS |
|-------------------------------|-----------------------|------------------------------------|------------------|---------------------------------------|-------------------|
| Nonsolder mask defined (NSMD) | 275 μm (+0.0, -25 μm) | 375 μm (+0.0, -25 μm) | 1 oz max (32 μm) | 275 μm x 275 μm Sq. (rounded corners) | 125 μm thick |

- (1) Circuit traces from NSMD defined PWB lands should be 75 μm to 100 μm wide in the exposed area inside the solder mask opening. Wider trace widths reduce device stand off and impact reliability.
- (2) Best reliability results are achieved when the PWB laminate glass transition temperature is above the operating the range of the intended application.
- (3) Recommend solder paste is Type 3 or Type 4.
- (4) For a PWB using a Ni/Au surface finish, the gold thickness should be less 0.5 μm to avoid a reduction in thermal fatigue performance.
- (5) Solder mask thickness should be less than 20 μm on top of the copper circuit pattern
- (6) Best solder stencil performance is achieved using laser cut stencils with electro polishing. Use of chemically etched stencils results in inferior solder paste volume control.
- (7) Trace routing away from WCSP device should be balanced in X and Y directions to avoid unintentional component movement due to solder wetting forces.

12.2 Layout Example

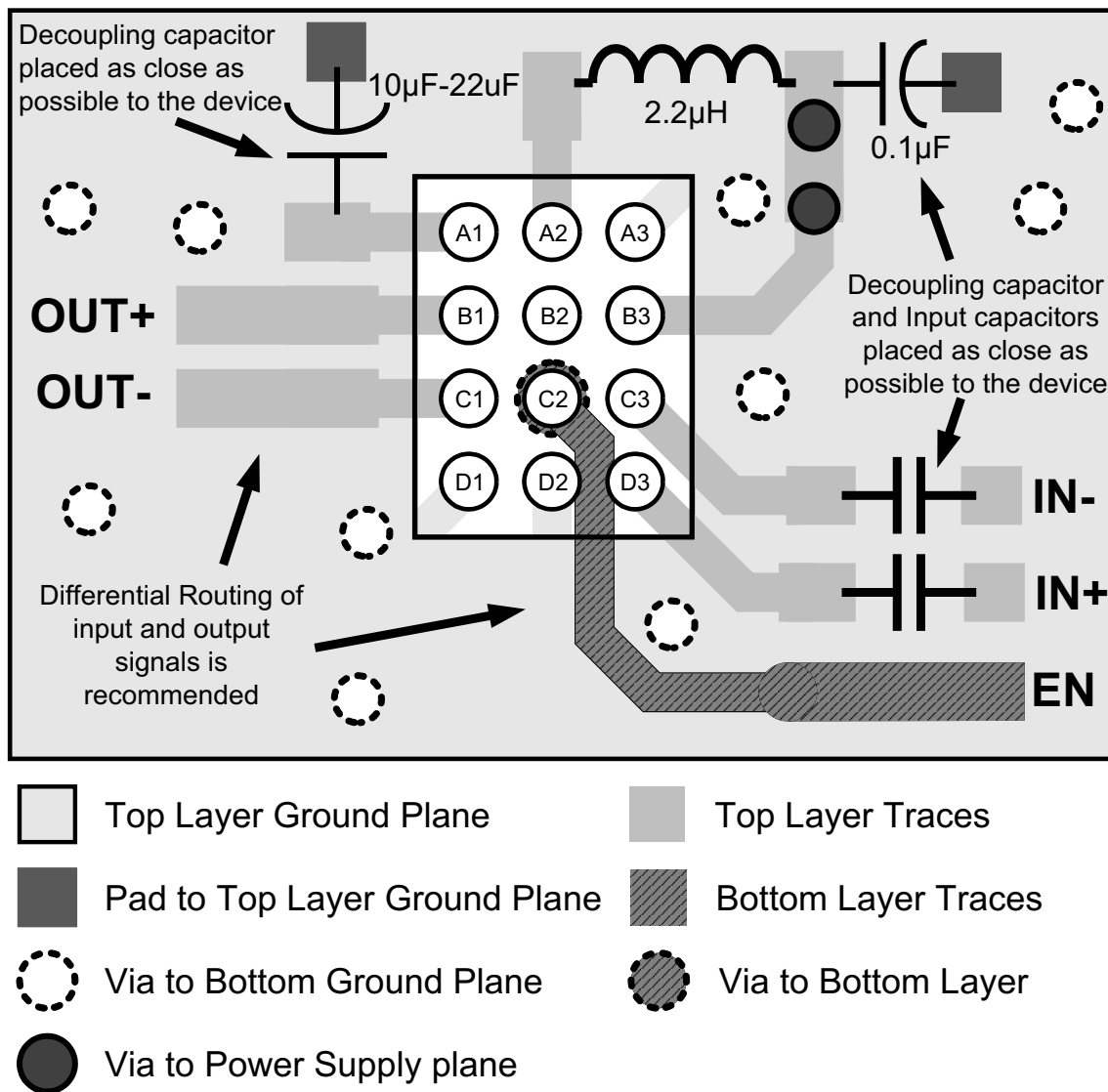

Figure 26. Layout Recommendation

13 Device and Documentation Support

13.1 Device Support

13.1.1 Third-Party Products Disclaimer

TI'S PUBLICATION OF INFORMATION REGARDING THIRD-PARTY PRODUCTS OR SERVICES DOES NOT CONSTITUTE AN ENDORSEMENT REGARDING THE SUITABILITY OF SUCH PRODUCTS OR SERVICES OR A WARRANTY, REPRESENTATION OR ENDORSEMENT OF SUCH PRODUCTS OR SERVICES, EITHER ALONE OR IN COMBINATION WITH ANY TI PRODUCT OR SERVICE.

13.1.2 Device Nomenclature

13.1.2.1 Boost Terms

The following is a list of terms and definitions used in the boost equations found in this document.

| | |
|--------------------|---|
| C | Minimum boost capacitance required for a given ripple voltage on PVDD. |
| L | Boost inductor |
| f_{BOOST} | Switching frequency of the boost converter. |
| I_{PVDD} | Current pulled by the Class-D amplifier from the boost converter. |
| I_L | Average current through the boost inductor. |
| PVDD | Supply voltage for the Class-D amplifier. (Voltage generated by the boost converter output) |
| VBAT | Supply voltage to the IC. |
| ΔI_L | Ripple current through the inductor. |
| ΔV | Ripple voltage on PVDD. |

13.2 Community Resources

The following links connect to TI community resources. Linked contents are provided "AS IS" by the respective contributors. They do not constitute TI specifications and do not necessarily reflect TI's views; see TI's [Terms of Use](#).

TI E2E™ Online Community *TI's Engineer-to-Engineer (E2E) Community*. Created to foster collaboration among engineers. At e2e.ti.com, you can ask questions, share knowledge, explore ideas and help solve problems with fellow engineers.

Design Support *TI's Design Support* Quickly find helpful E2E forums along with design support tools and contact information for technical support.

13.3 Trademarks

E2E is a trademark of Texas Instruments.
All other trademarks are the property of their respective owners.

13.4 Electrostatic Discharge Caution



These devices have limited built-in ESD protection. The leads should be shorted together or the device placed in conductive foam during storage or handling to prevent electrostatic damage to the MOS gates.

13.5 Glossary

[SLYZ022](#) — *TI Glossary*.

This glossary lists and explains terms, acronyms, and definitions.

14 Mechanical, Packaging, and Orderable Information

The following pages include mechanical, packaging, and orderable information. This information is the most current data available for the designated devices. This data is subject to change without notice and revision of this document. For browser-based versions of this data sheet, refer to the left-hand navigation.

14.1 Package Dimensions

The TPA2080D1 uses a 12-ball, 0.5-mm pitch WCSP package. The die length (D) and width (E) correspond to the package mechanical drawing at the end of the datasheet.

Table 8. TPA2080D1 YZG Package Dimensions

| DIMENSION | D | E |
|------------------|--------------------|--------------------|
| Max | 2012 μm | 1560 μm |
| Typ | 1982 μm | 1530 μm |
| Min | 1952 μm | 1500 μm |

PACKAGING INFORMATION

| Orderable Device | Status (1) | Package Type | Package Drawing | Pins | Package Qty | Eco Plan (2) | Lead finish/ Ball material (6) | MSL Peak Temp (3) | Op Temp (°C) | Device Marking (4/5) | Samples |
|------------------|---------------|--------------|-----------------|------|-------------|-----------------|--------------------------------------|----------------------|--------------|-------------------------|-------------------------|
| TPA2080D1YZGR | ACTIVE | DSBGA | YZG | 12 | 3000 | RoHS & Green | SNAGCU | Level-1-260C-UNLIM | -40 to 85 | TPA2080D1 | Samples |
| TPA2080D1YZGT | ACTIVE | DSBGA | YZG | 12 | 250 | RoHS & Green | SNAGCU | Level-1-260C-UNLIM | -40 to 85 | TPA2080D1 | Samples |

(1) The marketing status values are defined as follows:

ACTIVE: Product device recommended for new designs.

LIFEBUY: TI has announced that the device will be discontinued, and a lifetime-buy period is in effect.

NRND: Not recommended for new designs. Device is in production to support existing customers, but TI does not recommend using this part in a new design.

PREVIEW: Device has been announced but is not in production. Samples may or may not be available.

OBSELETE: TI has discontinued the production of the device.

(2) **RoHS:** TI defines "RoHS" to mean semiconductor products that are compliant with the current EU RoHS requirements for all 10 RoHS substances, including the requirement that RoHS substance do not exceed 0.1% by weight in homogeneous materials. Where designed to be soldered at high temperatures, "RoHS" products are suitable for use in specified lead-free processes. TI may reference these types of products as "Pb-Free".

RoHS Exempt: TI defines "RoHS Exempt" to mean products that contain lead but are compliant with EU RoHS pursuant to a specific EU RoHS exemption.

Green: TI defines "Green" to mean the content of Chlorine (Cl) and Bromine (Br) based flame retardants meet JS709B low halogen requirements of <=1000ppm threshold. Antimony trioxide based flame retardants must also meet the <=1000ppm threshold requirement.

(3) MSL, Peak Temp. - The Moisture Sensitivity Level rating according to the JEDEC industry standard classifications, and peak solder temperature.

(4) There may be additional marking, which relates to the logo, the lot trace code information, or the environmental category on the device.

(5) Multiple Device Markings will be inside parentheses. Only one Device Marking contained in parentheses and separated by a "~" will appear on a device. If a line is indented then it is a continuation of the previous line and the two combined represent the entire Device Marking for that device.

(6) Lead finish/Ball material - Orderable Devices may have multiple material finish options. Finish options are separated by a vertical ruled line. Lead finish/Ball material values may wrap to two lines if the finish value exceeds the maximum column width.

Important Information and Disclaimer:The information provided on this page represents TI's knowledge and belief as of the date that it is provided. TI bases its knowledge and belief on information provided by third parties, and makes no representation or warranty as to the accuracy of such information. Efforts are underway to better integrate information from third parties. TI has taken and continues to take reasonable steps to provide representative and accurate information but may not have conducted destructive testing or chemical analysis on incoming materials and chemicals. TI and TI suppliers consider certain information to be proprietary, and thus CAS numbers and other limited information may not be available for release.

In no event shall TI's liability arising out of such information exceed the total purchase price of the TI part(s) at issue in this document sold by TI to Customer on an annual basis.

TAPE AND REEL INFORMATION

QUADRANT ASSIGNMENTS FOR PIN 1 ORIENTATION IN TAPE

*All dimensions are nominal

| Device | Package Type | Package Drawing | Pins | SPQ | Reel Diameter (mm) | Reel Width W1 (mm) | A0 (mm) | B0 (mm) | K0 (mm) | P1 (mm) | W (mm) | Pin1 Quadrant |
|---------------|--------------|-----------------|------|------|--------------------|--------------------|---------|---------|---------|---------|--------|---------------|
| TPA2080D1YZGR | DSBGA | YZG | 12 | 3000 | 180.0 | 8.4 | 1.63 | 2.08 | 0.69 | 4.0 | 8.0 | Q1 |
| TPA2080D1YZGT | DSBGA | YZG | 12 | 250 | 180.0 | 8.4 | 1.63 | 2.08 | 0.69 | 4.0 | 8.0 | Q1 |

TAPE AND REEL BOX DIMENSIONS

*All dimensions are nominal

| Device | Package Type | Package Drawing | Pins | SPQ | Length (mm) | Width (mm) | Height (mm) |
|---------------|--------------|-----------------|------|------|-------------|------------|-------------|
| TPA2080D1YZGR | DSBGA | YZG | 12 | 3000 | 182.0 | 182.0 | 20.0 |
| TPA2080D1YZGT | DSBGA | YZG | 12 | 250 | 182.0 | 182.0 | 20.0 |

YZG (R-XBGA-N12)

DIE-SIZE BALL GRID ARRAY

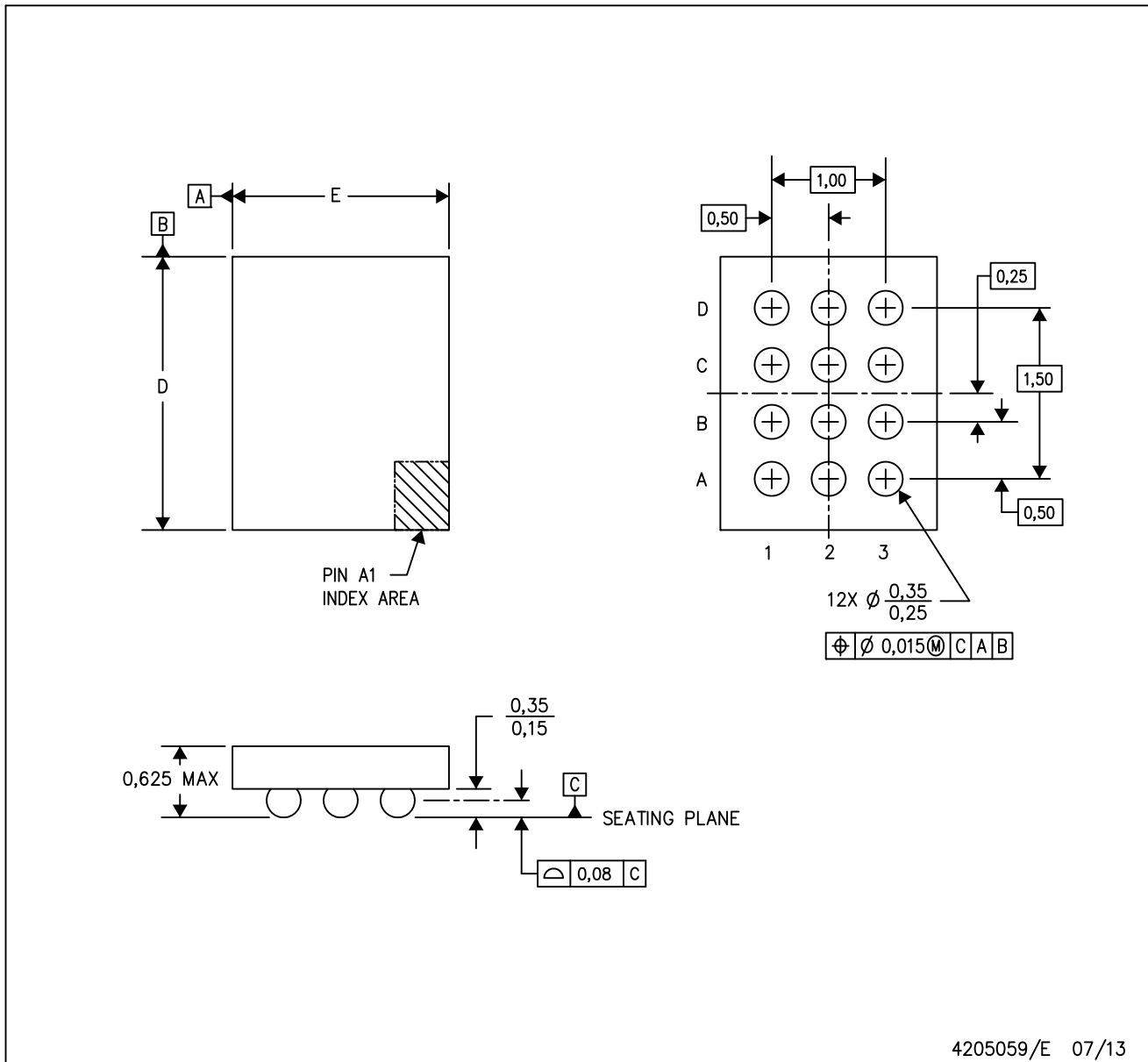

4205059/E 07/13

- NOTES: A. All linear dimensions are in millimeters. Dimensioning and tolerancing per ASME Y14.5M-1994.
 B. This drawing is subject to change without notice.
 C. NanoFree™ package configuration.

NanoFree is a trademark of Texas Instruments.

IMPORTANT NOTICE AND DISCLAIMER

TI PROVIDES TECHNICAL AND RELIABILITY DATA (INCLUDING DATASHEETS), DESIGN RESOURCES (INCLUDING REFERENCE DESIGNS), APPLICATION OR OTHER DESIGN ADVICE, WEB TOOLS, SAFETY INFORMATION, AND OTHER RESOURCES "AS IS" AND WITH ALL FAULTS, AND DISCLAIMS ALL WARRANTIES, EXPRESS AND IMPLIED, INCLUDING WITHOUT LIMITATION ANY IMPLIED WARRANTIES OF MERCHANTABILITY, FITNESS FOR A PARTICULAR PURPOSE OR NON-INFRINGEMENT OF THIRD PARTY INTELLECTUAL PROPERTY RIGHTS.

These resources are intended for skilled developers designing with TI products. You are solely responsible for (1) selecting the appropriate TI products for your application, (2) designing, validating and testing your application, and (3) ensuring your application meets applicable standards, and any other safety, security, or other requirements. These resources are subject to change without notice. TI grants you permission to use these resources only for development of an application that uses the TI products described in the resource. Other reproduction and display of these resources is prohibited. No license is granted to any other TI intellectual property right or to any third party intellectual property right. TI disclaims responsibility for, and you will fully indemnify TI and its representatives against, any claims, damages, costs, losses, and liabilities arising out of your use of these resources.

TI's products are provided subject to TI's Terms of Sale (<https://www.ti.com/legal/termsofsale.html>) or other applicable terms available either on [ti.com](https://www.ti.com) or provided in conjunction with such TI products. TI's provision of these resources does not expand or otherwise alter TI's applicable warranties or warranty disclaimers for TI products.

Mailing Address: Texas Instruments, Post Office Box 655303, Dallas, Texas 75265
Copyright © 2021, Texas Instruments Incorporated

Looking for pricing, stock, or lifecycle information?

Click below to explore more details on WIN SOURCE:

 [View TPA2080D1YZGT](#) on WIN SOURCE

 [Texas Instruments](#) Information

Optimize Your Supply Chain with WIN SOURCE Solutions

-  Global Sourcing Solution
-  Obsolete Management
-  Cost Control Management
-  Shortage Management
-  Alternative Solution
-  Excess Inventory Management