



**THE DATASHEET OF
TMS470R1A256PZ-T**



FEATURES

- High-Performance Static CMOS Technology
- TMS470R1x 16/32-Bit RISC Core (ARM7TDMI™)
 - 24-MHz System Clock (48-MHz Pipeline Mode)
 - Independent 16/32-Bit Instruction Set
 - Open Architecture With Third-Party Support
 - Built-In Debug Module
 - Big-Endian Format Utilized
- Integrated Memory
 - 256K-Byte Program Flash
 - One Bank With 14 Contiguous Sectors
 - Internal State Machine for Programming and Erase
 - 12K-Byte Static RAM (SRAM)
- Operating Features
 - Core Supply Voltage (V_{CC}): 1.81 V–2.05 V
 - I/O Supply Voltage (V_{CCIO}): 3.0 V–3.6 V
 - Low-Power Modes: STANDBY and HALT
 - Extended Industrial Temperature Ranges
- 470+ System Module
 - 32-Bit Address Space Decoding
 - Bus Supervision for Memory and Peripherals
 - Analog Watchdog (AWD) Timer
 - Real-Time Interrupt (RTI)
 - System Integrity and Failure Detection
- Zero-Pin Phase-Locked Loop (ZPLL)-Based Clock Module With Prescaler
 - Multiply-by-4 or -8 Internal ZPLL Option
 - ZPLL Bypass Mode
- Six Communication Interfaces:
 - Two Serial Peripheral Interfaces (SPIs)
 - 255 Programmable Baud Rates
 - Two Serial Communications Interfaces (SCIs)
 - 2^{24} Selectable Baud Rates
 - Asynchronous/Isosynchronous Modes
 - Standard CAN Controller (SCC)
 - 16-Mailbox Capacity
 - Fully Compliant With CAN Protocol, Version 2.0B
 - Class II Serial Interface (C2S1b)
 - Two Selectable Data Rates
 - Normal Mode 10.4 Kbps and 4X Mode 41.6 Kbps
- High-End Timer (HET)
 - 16 Programmable I/O Channels:
 - 14 High-Resolution Pins
 - 2 Standard-Resolution Pins
 - High-Resolution Share Feature (XOR)
 - High-End Timer RAM
 - 64-Instruction Capacity
- 10-Bit Multi-Buffered ADC (MibADC) 16-Channel
 - 64-Word FIFO Buffer
 - Single- or Continuous-Conversion Modes
 - 1.55 μ s Minimum Sample and Conversion Time
 - Calibration Mode and Self-Test Features
- 8 External Interrupts
- Flexible Interrupt Handling
- 11 Dedicated GIO Pins, 1 Input-Only GIO Pin, and 38 Additional Peripheral I/Os (A256)
- External Clock Prescale (ECP) Module
 - Programmable Low-Frequency External Clock (CLK)
- Compatible ROM Device
- On-Chip Scan-Base Emulation Logic, IEEE Standard 1149.1 (JTAG) Test-Access Port ⁽¹⁾
- 100-Pin Plastic Low-Profile Quad Flatpack (PZ Suffix)

(1) The test-access port is compatible with the IEEE Standard 1149.1-1990, IEEE Standard Test-Access Port and Boundary Scan Architecture. Boundary scan is not supported on this device.



Please be aware that an important notice concerning availability, standard warranty, and use in critical applications of Texas Instruments semiconductor products and disclaimers thereto appears at the end of this data sheet.

ARM7TDMI is a trademark of Advanced RISC Machines Limited (ARM).
All other trademarks are the property of their respective owners.

TMS470R1A256

16/32-Bit RISC Flash Microcontroller

SPNS100B–NOVEMBER 2004–REVISED AUGUST 2006

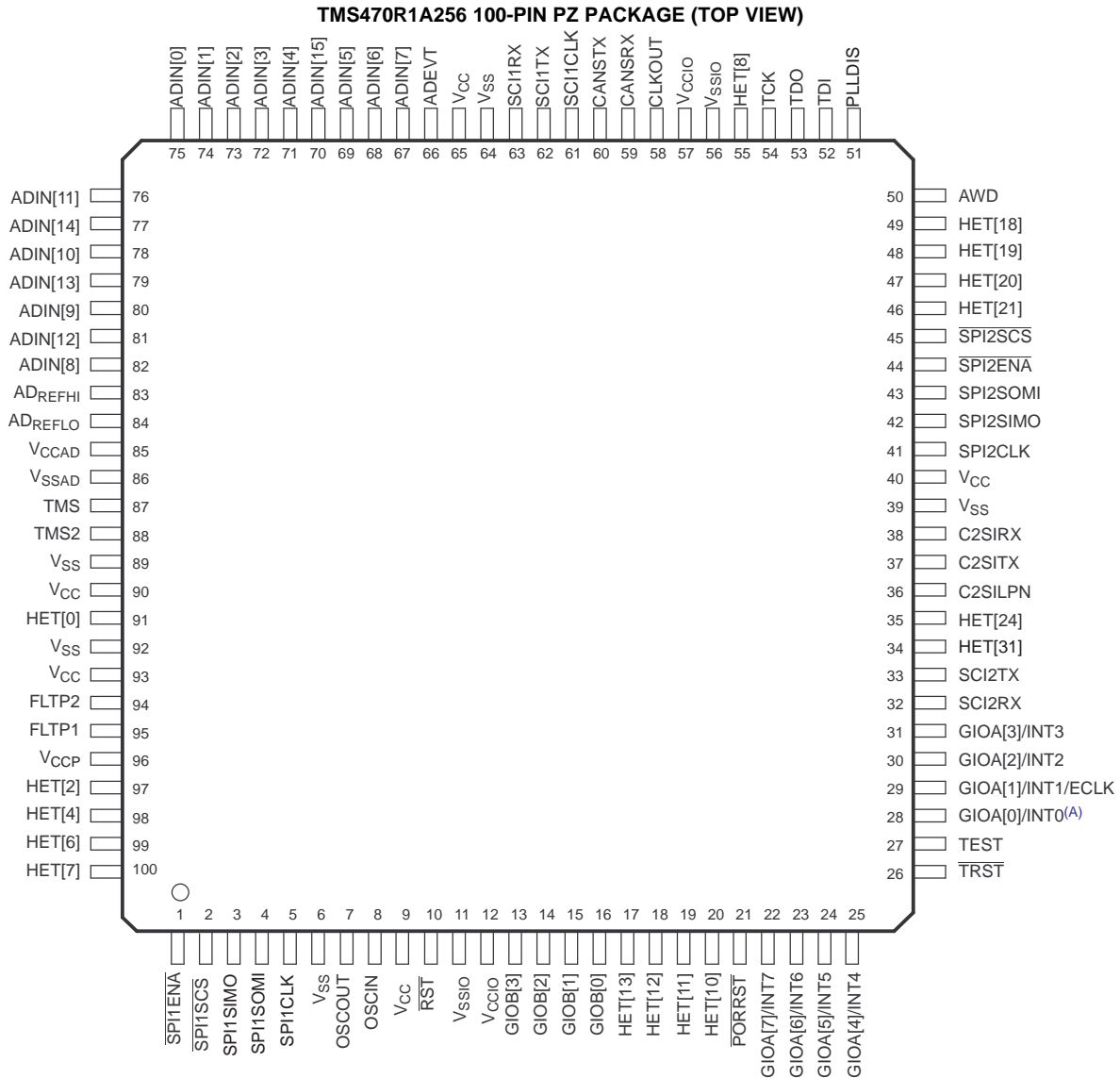

A. GIOA[0]/INT0 (pin 28) is an input-only GIO pin.

DESCRIPTION

The TMS470R1A256⁽²⁾ devices are members of the Texas Instruments TMS470R1x family of general-purpose 16/32-bit reduced instruction set computer (RISC) microcontrollers. The A256 microcontroller offers high performance utilizing the high-speed ARM7TDMI 16/32-bit RISC central processing unit (CPU), resulting in a high instruction throughput while maintaining greater code efficiency. The ARM7TDMI 16/32-bit RISC CPU views memory as a linear collection of bytes numbered upwards from 0. The TMS470R1A256 utilizes the big-endian format where the most significant byte of a word is stored at the lowest numbered byte and the least significant byte at the highest numbered byte.

High-end embedded control applications demand more performance from their controllers while maintaining low costs. The A256 RISC core architecture offers solutions to these performance and cost demands while maintaining low power consumption.

(2) Throughout the remainder of this document, the TMS470R1A256 device name will be referred to as either the full device name, TMS470R1A256, or as A256.

The A256 device contains the following:

- ARM7TDMI 16/32-Bit RISC CPU
- TMS470R1x system module (SYS) with 470+ enhancements
- 256K-byte flash
- 12K-byte SRAM
- Zero-pin phase-locked loop (ZPLL) clock module
- Analog watchdog (AWD) timer
- Real-time interrupt (RTI) module
- Two serial peripheral interface (SPI) modules
- Two serial communications interface (SCI) modules
- Standard CAN controller (SCC)
- Class II serial interface (C2S1b)
- 10-bit multi-buffered analog-to-digital converter (MibADC), 16-input channels
- High-end timer (HET) controlling 16 I/Os
- External clock prescale (ECP) module
- Up to 49 I/O pins and 1 input-only pin

The functions performed by the 470+ system module (SYS) include:

- Address decoding
- Memory protection
- Memory and peripherals bus supervision
- Reset and abort exception management
- Prioritization for all internal interrupt sources
- Device clock control
- Parallel signature analysis (PSA)
- This data sheet includes device-specific information such as memory and peripheral select assignment, interrupt priority, and a device memory map. For a more detailed functional description of the SYS module, see the *TMS470R1x System Module Reference Guide* (literature number SPNU189).

The A256 memory includes general-purpose SRAM supporting single-cycle read/write accesses in byte, half-word, and word modes.

The flash memory on this device is a nonvolatile, electrically erasable and programmable memory implemented with a 32-bit-wide data bus interface. In pipeline mode, the flash operates with a system clock frequency of up to 48 MHz. In normal mode, the flash operates with a system clock frequency of up to 24 MHz. For more detailed information on the flash, see the *F05 flash* section of this data sheet and the *TMS470R1x F05 Flash Reference Guide* (literature number SPNU213).

The A256 device has six communication interfaces: two SPIs, two SCIs, an SCC, and a C2S1b. The SPI provides a convenient method of serial interaction for high-speed communications between similar shift-register type devices. The SCI is a full-duplex, serial I/O interface intended for asynchronous communication between the CPU and other peripherals using the standard non-return-to-zero (NRZ) format. The SCC uses a serial, multimaster communication protocol that efficiently supports distributed real-time control with robust communication rates of up to 1 megabit per second (Mbps). The SCC is ideal for applications operating in noisy and harsh environments (e.g., industrial fields) that require reliable serial communication or multiplexed wiring. The C2S1b allows the A256 to transmit and receive messages on a class II network following an SAE J1850⁽³⁾ standard. For more detailed functional information on the SPI, SCI, and SCC peripherals, see the specific reference guides (literature numbers SPNU195, SPNU196, and SPNU197, respectively). For more detailed functional information on the C2S1b peripheral, see the *TMS470R1x Class II Serial Interface B (C2S1b) Reference Guide* (literature number SPNU214).

(3) SAE Standard J1850 Class B Data Communication Network Interface

The HET is an advanced intelligent timer that provides sophisticated timing functions for real-time applications. The timer is software-controlled, using a reduced instruction set, with a specialized timer micromachine and an attached I/O port. The HET can be used for compare, capture, or general-purpose I/O. It is especially well suited for applications requiring multiple sensor information and drive actuators with complex and accurate time pulses. For more detailed functional information on the HET, see the *TMS470R1x High-End Timer (HET) Reference Guide* (literature number SPNU199).

The A256 HET peripheral contains the XOR-share feature. This feature allows two adjacent HET high-resolution channels to be XORed together, making it possible to output smaller pulses than a standard HET. For more detailed information on the HET XOR-share feature, see the *TMS470R1x High-End Timer (HET) Reference Guide* (literature number SPNU199).

The A256 device has a 10-bit-resolution sample-and-hold MibADC. The MibADC channels can be converted individually or can be grouped by software for sequential conversion sequences. There are three separate groupings, two of which are triggerable by an external event. Each sequence can be converted once when triggered or configured for continuous conversion mode. For more detailed functional information on the MibADC, see the *TMS470R1x Multi-Buffered Analog-to-Digital Converter (MibADC) Reference Guide* (literature number SPNU206).

The zero-pin phase-locked loop (ZPLL) clock module contains a phase-locked loop, a clock-monitor circuit, a clock-enable circuit, and a prescaler (with prescale values of 1–8). The function of the ZPLL is to multiply the external frequency reference to a higher frequency for internal use. The ZPLL provides ACLK to the system (SYS) module. The SYS module subsequently provides the system clock (SYSCLK), real-time interrupt clock (RTICK), CPU clock (MCLK), and peripheral interface clock (ICK) to all other A256 device modules. For more detailed functional information on the ZPLL, see the *TMS470R1x Zero-Pin Phase Locked Loop (ZPLL) Clock Module Reference Guide* (literature number SPNU212).

NOTE:

ACLK should not be confused with the MibADC internal clock, ADCLK. ACLK is the continuous system clock from an external resonator/crystal reference.

The A256 device also has an external clock prescaler (ECP) module that when enabled, outputs a continuous external clock (ECLK) on a specified GIO pin. The ECLK frequency is a user-programmable ratio of the peripheral interface clock (ICK) frequency. For more detailed functional information on the ECP, see the *TMS470R1x External Clock Prescaler (ECP) Reference Guide* (literature number SPNU202).

Device Characteristics

The TMS470R1A256 device is a derivative of the F05 system emulation device SE470R1VB8AD. Table 1 identifies all the characteristics of the TMS470R1A256 device except the SYSTEM and CPU, which are generic.

Table 1. Device Characteristics

CHARACTERISTICS	DEVICE DESCRIPTION	COMMENTS
MEMORY		
For the number of memory selects on this device, see the "Memory Selection Assignment" table (Table 2).		
INTERNAL MEMORY	256K-Byte flash 12K-Byte SRAM	Flash is pipeline-capable. The A256 RAM is implemented in one 12K array selected by two memory-select signals (see the "Memory Selection Assignment" table, Table 2).
PERIPHERALS		
For the device-specific interrupt priority configurations, see the "Interrupt Priority" table (Table 4). For the 1K peripheral address ranges and their peripheral selects, see the "A256 Peripherals, System Module, and Flash Base Addresses" table (Table 3).		
CLOCK	ZPLL	Zero-pin PLL has no external loop filter pins.
GENERAL-PURPOSE I/Os	11 I/O 1 Input only	Port A has 8 external pins and Port B has 4 external pins.
ECP	YES	
C2S1b	1	
SCI	1 (3-pin) 1 (2-pin)	SCI2 has no external clock pin, only transmit/receive pins (SCI2TX and SCI2RX)
CAN (HECC and/or SCC)	1 SCC	Standard CAN controller
SPI (5-pin, 4-pin or 3-pin)	2 (5-pin)	
HET with XOR Share	16 I/O	The A256 devices have both the logic and registers for a full 32-I/O HET to be implemented, even though not all 32 pins are available externally. The high-resolution (HR) SHARE feature allows even HR pins to share the next higher odd-numbered HR pin structures. This HR sharing is independent of whether or not the odd pin is available externally. If an odd pin is available externally and shared, then the odd pin can only be used as a general-purpose I/O. For more information on HR SHARE, see the <i>TMS470R1x High-End Timer (HET) Reference Guide</i> (literature number SPNU199).
HET RAM	64-Instruction Capacity	
MibADC	10-bit, 16-channel 64-word FIFO	Both the logic and registers for a full 16-channel MibADC are present. The MibADC is capable of being event-triggered from a user-selectable event source.
CORE VOLTAGE	1.81–2.05 V	
I/O VOLTAGE	3.0–3.6 V	
PINS	100	
PACKAGE	PZ	

Functional Block Diagram

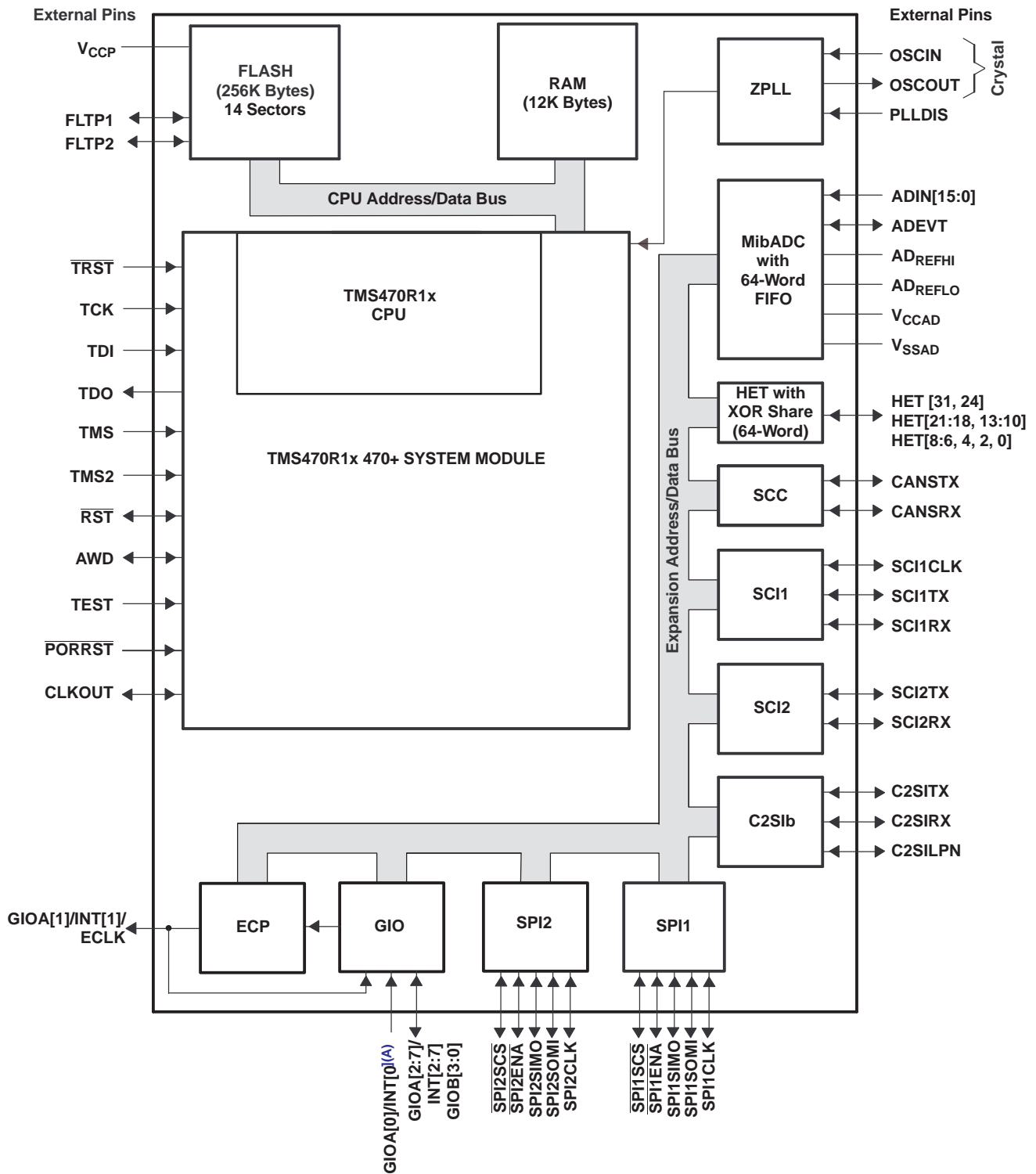

A. GIOA[0]/INT[0] is an input-only GIO pin.

Table 2. Terminal Functions

TERMINAL		TYPE ⁽¹⁾⁽²⁾	INTERNAL PULLUP/ PULLDOWN ⁽³⁾	DESCRIPTION			
NAME	PIN NUMBER						
HIGH-END TIMER (HET)							
HET[0]	91	3.3-V I/O	IPD	<p>The A256 devices have both the logic and registers for a full 32-I/O HET implemented, even though not all 32 pins are available externally</p> <p>Timer input capture or output compare. The HET[31:0] applicable pins can be programmed as general-purpose input/output (GIO) pins.</p> <p>HET[21:18, 13:10, 8:6, 4, 2, 0] are high-resolution pins and HET[31, 24] are standard-resolution pins for A256.</p> <p>The high-resolution (HR) SHARE feature allows even-numbered HR pins to share the next higher odd-numbered HR pin structures. This HR sharing is independent of whether or not the odd pin is available externally. If an odd pin is available externally and shared, then the odd pin can only be used as a general-purpose I/O. For more information on HR SHARE, see the <i>TMS470R1x High-End Timer (HET) Reference Guide</i> (literature number SPNU199).</p> <p>The HET[19] or HET[18] pins can also be used as a user-selectable event source to event trigger the MibADC event group or group1 if the associated register source bits are properly configured and defined. For the internal device connections, see the MibADC section of this data sheet. For more detailed information on the MibADC, see the <i>TMS470R1x Multi-Buffered Analog-to-Digital Converter (MibADC) Reference Guide</i> (literature number SPNU206).</p>			
HET[1]	-						
HET[2]	97						
HET[3]	-						
HET[4]	98						
HET[5]	-						
HET[6]	99						
HET[7]	100						
HET[8]	55						
HET[9]	-						
HET[10]	20						
HET[11]	19						
HET[12]	18						
HET[13]	17						
HET[14]	-						
HET[15]	-						
HET[16]	-						
HET[17]	-						
HET[18]	49						
HET[19]	48						
HET[20]	47						
HET[21]	46						
HET[22]	-						
HET[24]	35						
HET[28]	-						
HET[29]	-						
HET[30]	-						
HET[31]	34						
STANDARD CAN CONTROLLER (SCC)							
CANSRX	59				3.3-V I/O		SCC receive pin or GIO pin
CANSTX	60				3.3-V I/O	IPU	SCC transmit pin or GIO pin
CLASS II SERIAL INTERFACE (C2SIb)							
C2SILPN	36	3.3-V I/O	IPD	C2SIb module loopback enable pin or GIO pin			
C2SIRX	38	3.3-V I/O		C2SIb module receive data input pin or GIO pin			
C2SITX	37	3.3-V I/O	IPD	C2SIb module transmit data output pin or GIO pin			

(1) I = input, O = output, PWR = power, GND = ground, REF = reference voltage, NC = no connect

(2) All I/O pins, except \overline{RST} , are configured as inputs while \overline{PORRST} is low and immediately after \overline{PORRST} goes high.

(3) IPD = internal pulldown, IPU = internal pullup (all internal pullups and pulldowns are active on input pins, independent of the \overline{PORRST} state.)

Table 2. Terminal Functions (continued)

TERMINAL		TYPE ⁽¹⁾⁽²⁾	INTERNAL PULLUP/ PULLDOWN ⁽³⁾	DESCRIPTION			
NAME	PIN NUMBER						
GENERAL-PURPOSE I/O (GIO)							
GIOA[0]/INT0	28	3.3-V I	IPD	<p>General-purpose input/output pins.</p> <p>GIOA[0]/INT[0] is an input-only pin. GIOA[7:0]/INT[7:0] are interrupt-capable pins.</p> <p>GIOA[1]/INT[1]/ECLK pin is multiplexed with the external clock-out function of the external clock prescale (ECP) module.</p>			
GIOA[1]/INT1/ ECLK	29	3.3-V I/O					
GIOA[2]/INT2	30						
GIOA[3]/INT3	31						
GIOA[4]/INT4	25						
GIOA[5]/INT5	24						
GIOA[6]/INT6	23						
GIOA[7]/INT7	22						
GIOB[0]	16						
GIOB[1]	15						
GIOB[2]	14						
GIOB[3]	13						
MULTI-BUFFERED ANALOG-TO-DIGITAL CONVERTER (MibADC)							
ADEVT	66				3.3-V I/O	IPD	<p>MibADC event input. ADEVT can be programmed as a GIO pin. The ADEVT pin can also be used as a user-selectable event source to event trigger the MibADC event group or group1 if the associated register source bits are properly configured and defined. For the internal device connections, see the MibADC section of this data sheet.</p> <p>MibADC analog input pins</p>
ADIN[0]	75	3.3-V I					
ADIN[1]	74						
ADIN[2]	73						
ADIN[3]	72						
ADIN[4]	71						
ADIN[5]	69						
ADIN[6]	68						
ADIN[7]	67						
ADIN[8]	82						
ADIN[9]	80						
ADIN[10]	78						
ADIN[11]	76						
ADIN[12]	81						
ADIN[13]	79						
ADIN[14]	77						
ADIN[15]	70						
AD _{REFHI}	83	3.3-V REF I		MibADC module high-voltage reference input			
AD _{REFLO}	84	GND REF I		MibADC module low-voltage reference input			
V _{CCAD}	85	3.3-V PWR		MibADC analog supply voltage			
V _{SSAD}	86	GND		MibADC analog ground reference.			

Table 2. Terminal Functions (continued)

TERMINAL		TYPE ⁽¹⁾⁽²⁾	INTERNAL PULLUP/ PULLDOWN ⁽³⁾	DESCRIPTION
NAME	PIN NUMBER			
SERIAL PERIPHERAL INTERFACE 1 (SPI1)				
SPI1CLK	5	3.3-V I/O	IPD	SPI1 clock. SPI1CLK can be programmed as a GIO pin.
SPI1ENA	1			SPI1 chip enable. $\overline{\text{SPI1ENA}}$ can be programmed as a GIO pin.
SPI1SCS	2			SPI1 slave chip select. $\overline{\text{SPI1SCS}}$ can be programmed as a GIO pin.
SPI1SIMO	3			SPI1 data stream. Slave in/master out. SPI1SIMO can be programmed as a GIO pin.
SPI1SOMI	4			SPI1 data stream. Slave out/master in. SPI1SOMI can be programmed as a GIO pin.
SERIAL PERIPHERAL INTERFACE 2 (SPI2)				
SPI2CLK	41	3.3-V I/O	IPD	SPI2 clock. SPI2CLK can be programmed as a GIO pin.
SPI2ENA	44			SPI2 chip enable. $\overline{\text{SPI2ENA}}$ can be programmed as a GIO pin.
SPI2SCS	45			SPI2 slave chip select. $\overline{\text{SPI2SCS}}$ can be programmed as a GIO pin.
SPI2SIMO	42			SPI2 data stream. Slave in/master out. SPI2SIMO can be programmed as a GIO pin.
SPI2SOMI	43			SPI2 data stream. Slave out/master in. SPI2SOMI can be programmed as a GIO pin.
ZERO-PIN PHASE-LOCKED LOOP (ZPLL)				
OSCIN	8	1.8-V I		Crystal connection pin or external clock input
OSCOU	7	1.8-V O		External crystal connection pin
PLLDIS	51	3.3-V I	IPD	Enable/disable the ZPLL. The ZPLL can be bypassed and the oscillator becomes the system clock. If not in bypass mode, TI recommends that PLLDIS be connected to ground or pulled down to ground by an external resistor.
SERIAL COMMUNICATIONS INTERFACE 1 (SCI1)				
SCI1CLK	61	3.3-V I/O	IPD	SCI1 clock. SCI1CLK can be programmed as a GIO pin.
SCI1RX	63	3.3-V I/O	IPU	SCI1 data receive. SCI1RX can be programmed as a GIO pin.
SCI1TX	62	3.3-V I/O	IPU	SCI1 data transmit. SCI1TX can be programmed as a GIO pin.
SERIAL COMMUNICATIONS INTERFACE 2 (SCI2)				
SCI2RX	32	3.3-V I/O	IPU	SCI2 data receive. SCI2RX can be programmed as a GIO pin.
SCI2TX	33	3.3-V I/O	IPU	SCI2 data transmit. SCI2TX can be programmed as a GIO pin.
SYSTEM MODULE (SYS)				
CLKOUT	58	3.3-V I/O	IPD	Bidirectional pin. CLKOUT can be programmed as a GIO pin or the output of SYSCLK, ICLK, or MCLK.
$\overline{\text{PORRST}}$	21	3.3-V I	IPD	Input master chip power-up reset. External V_{CC} monitor circuitry must assert a power-on reset.
$\overline{\text{RST}}$	10	3.3-V I/O	IPU	Bidirectional reset. The internal circuitry can assert a reset, and an external system reset can assert a device reset. On $\overline{\text{RST}}$, the output buffer is implemented as an open drain (drives low only). To ensure an external reset is not arbitrarily generated, TI recommends that an external pullup resistor be connected to $\overline{\text{RST}}$.
WATCHDOG/REAL-TIME INTERRUPT (WD/RTI)				
AWD	50	3.3-V I/O	IPD	<p>Analog watchdog reset. The AWD pin provides a system reset if the WD KEY is not written in time by the system, providing an external RC network circuit is connected. If the user is not using AWD, TI recommends that AWD be connected to ground or pulled down to ground by an external resistor.</p> <p>For more details on the external RC network circuit, see the <i>TMS470R1x System Module Reference Guide</i> (literature number SPNU189) and the application note <i>Analog Watchdog Resistor, Capacitor and Discharge Interval Selection Constraints</i> (literature number SPNA005).</p>

Table 2. Terminal Functions (continued)

TERMINAL		TYPE ⁽¹⁾⁽²⁾	INTERNAL PULLUP/ PULLDOWN ⁽³⁾	DESCRIPTION
NAME	PIN NUMBER			
TEST/DEBUG (T/D)				
TCK	54	3.3-V I	IPD	Test clock. TCK controls the test hardware (JTAG)
TDI	52	3.3-V I	IPU	Test data in. TDI inputs serial data to the test instruction register, test data register, and programmable test address (JTAG).
TDO	53	3.3-V O	IPD	Test data out. TDO outputs serial data from the test instruction register, test data register, identification register, and programmable test address (JTAG).
TEST	27	3.3-V I	IPD	Test enable. Reserved for internal use only. TI recommends that TEST be connected to ground or pulled down to ground by an external resistor.
TMS	87	3.3-V I	IPU	Serial input for controlling the state of the CPU test access port (TAP) controller (JTAG)
TMS2	88	3.3-V I	IPU	Serial input for controlling the second TAP. TI recommends that TMS2 be connected to VCCIO or pulled up to VCCIO by an external resistor.
TRST	26	3.3-V I	IPD	Test hardware reset to TAP1 and TAP2. IEEE Standard 1149-1 (JTAG) Boundary-Scan Logic. TI recommends that TRST be pulled down to ground by an external resistor.
FLASH				
FLTP1	95	NC		Flash test pads 1 and 2. For proper operation, these pins must not be connected (no connect [NC]).
FLTP2	94			
V _{CCP}	96	3.3-V PWR		Flash external pump voltage (3.3 V)
SUPPLY VOLTAGE CORE (1.8 V)				
V _{CC}	9	1.8-V PWR		Core logic supply voltage
	40			
	65			
	90			
	93			
SUPPLY VOLTAGE DIGITAL I/O (3.3 V)				
V _{CCIO}	12	3.3-V PWR		Digital I/O supply voltage
	57			
SUPPLY GROUND CORE				
V _{SS}	6	GND		Core supply ground reference
	39			
	64			
	89			
	92			
SUPPLY GROUND DIGITAL I/O				
V _{SSIO}	11	GND		Digital I/O supply ground reference
	56			

A256 DEVICE-SPECIFIC INFORMATION

Memory

Figure 1 shows the memory map of the A256 device.

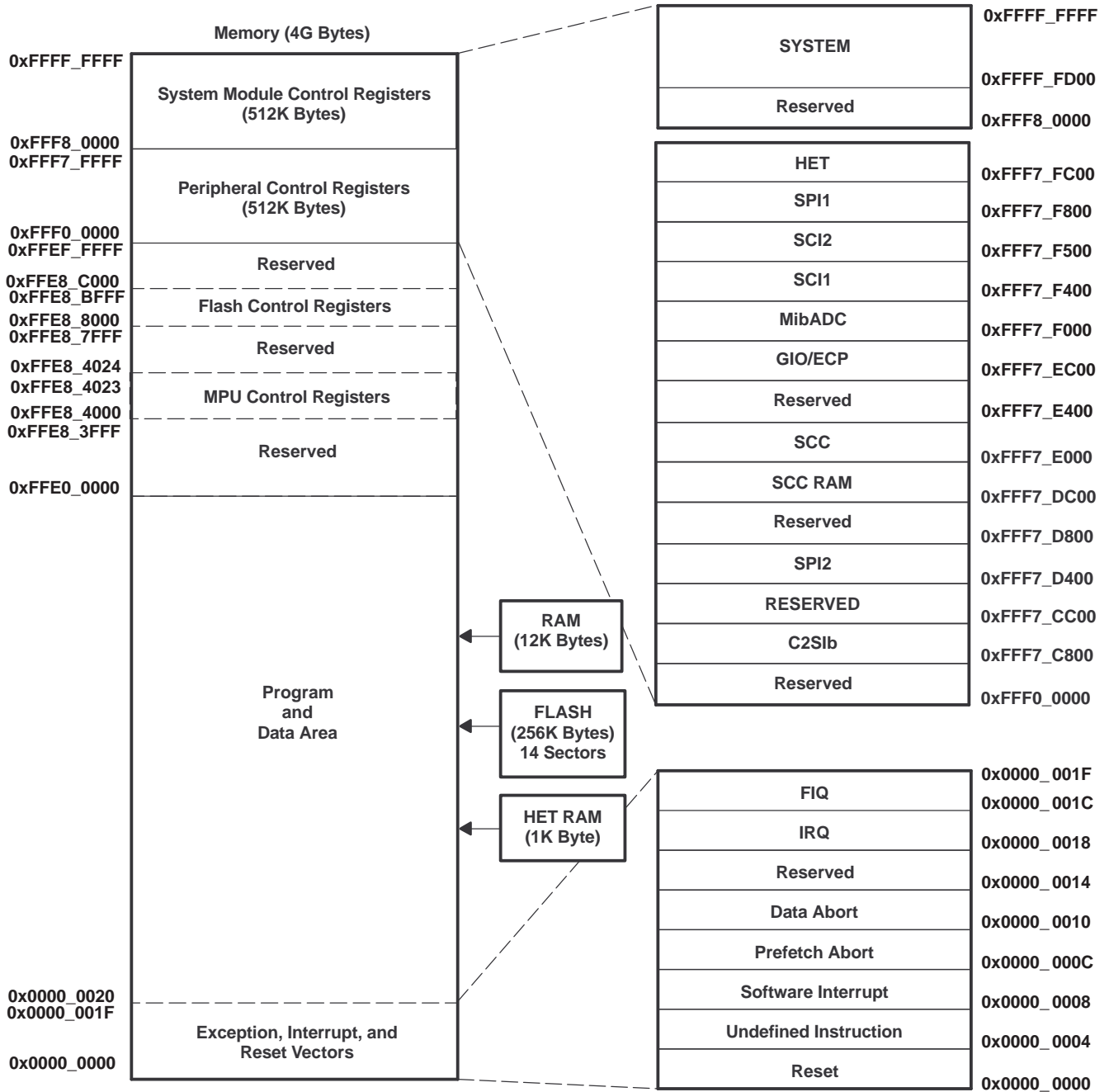

- A. Memory addresses are configurable by the system (SYS) module within the range of 0x0000_0000 to 0xFFE0_0000.
- B. The CPU registers are not part of the memory map.

Figure 1. Memory Map

Memory Selects

Memory selects allow the user to address memory arrays (i.e., flash, RAM, and HET RAM) at user-defined addresses. Each memory select has its own set (low and high) of memory base address registers (MFBAHRx and MFBALRx) that together define the array's starting (base) address, block size, and protection.

The base address of each memory select is configurable to any memory address boundary that is a multiple of the decoded block size. For more information on how to control and configure these memory select registers, see the bus structure and memory sections of the *TMS470R1x System Module Reference Guide* (literature number SPNU189).

For the memory selection assignments and the memory selected, see [Table 3](#).

Table 3. Memory Selection Assignment

MEMORY SELECT	MEMORY SELECTED (ALL INTERNAL)	MEMORY SIZE	MPU	MEMORY BASE ADDRESS REGISTER	STATIC MEM CTL REGISTER
0 (fine)	FLASH	256K	NO	MFBAHR0 and MFBALR0	
1 (fine)	FLASH		NO	MFBAHR1 and MFBALR1	
2 (fine)	RAM	12K ⁽¹⁾	YES	MFBAHR2 and MFBALR2	
3 (fine)	RAM		YES	MFBAHR3 and MFBALR3	
4 (fine)	HET RAM	1K		MFBAHR4 and MFBALR4	SMCR1

(1) The starting addresses for both RAM memory-select signals cannot be offset from each other by a multiple of the user-defined block size in the memory-base address register.

RAM

The A256 device contains 12K bytes of internal static RAM configurable by the SYS module to be addressed within the range of 0x0000_0000 to 0xFFE0_0000. This RAM is implemented in one 12K-byte array selected by two memory-select signals. This configuration imposes an additional constraint on the memory map for RAM; the starting addresses for both RAM memory selects cannot be offset from each other by the multiples of the size of the physical RAM (i.e., 12K bytes for the A256 device). The RAM is addressed through memory selects 2 and 3.

The RAM can be protected by the memory protection unit (MPU) portion of the SYS module, allowing the user finer blocks of memory protection than is allowed by the memory selects. The MPU is ideal for protecting an operating system while allowing access to the current task. For more detailed information on the MPU portion of the SYS module and memory protection, see the memory section of the *TMS470R1x System Module Reference Guide* (literature number SPNU189).

F05 flash

The F05 flash memory is a nonvolatile electrically erasable, and programmable memory implemented with a 32-bit-wide data bus interface. The F05 flash has an external state machine for programming and erase functions. See the flash read and flash program and erase sections of this document.

flash protection keys

The A256 device provides flash protection keys. These four 32-bit protection keys prevent program/erase/compaction operations from occurring until after the four protection keys have been matched by the CPU loading the correct user keys into the FMPKEY control register. The protection keys on the A256 are located in the last 4 words of the first 8K sector. For more detailed information on the flash protection keys and the FMPKEY control register, see the protection keys portions of the *TMS470R1x F05 Flash Reference Guide* (literature number SPNU213).

flash read

The A256 flash memory is configurable by the SYS module to be addressed within the range of 0x0000_0000 to 0xFFE0_0000. The flash is addressed through memory selects 0 and 1.

NOTE:

The flash external pump voltage (V_{CCP}) is required for all operations (program, erase, and read).

flash pipeline mode

When in pipeline mode, the flash operates with a system clock frequency of up to 48 MHz. In normal mode, it operates with a system clock frequency of up to 24 MHz. Flash in pipeline mode is capable of accessing 64-bit words and provides two 32-bit pipelined words to the CPU. Also in pipeline mode, the flash can be read with no wait states when memory addresses are contiguous (after the initial 1-or 2-wait-state reads).

NOTE:

After a system reset, pipeline mode is disabled (ENPIPE bit FMREGOPT[0] = 0). In other words, the A256 device powers up and comes out of reset in non-pipeline mode. Furthermore, setting the flash configuration mode bit (GLBCTRL[4]) will override pipeline mode.

flash program and erase

The A256 device flash has one 256K-byte bank that consists of 14 sectors. These 14 sectors are sized as follows:

SECTOR NO.	SEGMENT	LOW ADDRESS	HIGH ADDRESS
0	8K Bytes	0x00000000	0x00001FFF
1	8K Bytes	0x00002000	0x00003FFF
2	8K Bytes	0x00004000	0x00005FFF
3	8K Bytes	0x00006000	0x00007FFF
4	32K Bytes	0x00008000	0x0000FFFF
5	32K Bytes	0x00010000	0x00017FFF
6	32K Bytes	0x00018000	0x0001FFFF
7	32K Bytes	0x00020000	0x00027FFF
8	32K Bytes	0x00028000	0x0002FFFF
9	32K Bytes	0x00030000	0x00037FFF
10	8K Bytes	0x00038000	0x00039FFF
11	8K Bytes	0x0003A000	0x0003BFFF
12	8K Bytes	0x0003C000	0x0003DFFF
13	8K Bytes	0x0003E000	0x0003FFFF

The minimum size for an erase operation is one sector. The maximum size for a program operation is one 16-bit word.

NOTE:

The flash external pump voltage (V_{CCP}) is required for all operations (program, erase, and read).

For more detailed information on flash program and erase operations, see the *TMS470R1x F05 Flash Reference Guide* (literature number SPNU213).

HET RAM

The A256 device contains HET RAM. The HET RAM has a 64-instruction capability. The HET RAM is configurable by the SYS module to be addressed within the range of 0x0000_0000 to 0xFFE0_0000. The HET RAM is addressed through memory select 4.

Peripheral Selects and Base Addresses

The A256 device uses 10 of the 16 peripheral selects to decode the base addresses of the peripherals. These peripheral selects are fixed and transparent to the user since they are part of the decoding scheme used by the SYS module.

Control registers for the peripherals, SYS module, and flash begin at the base addresses shown in [Table 4](#).

Table 4. A256 Peripherals, System Module, and Flash Base Addresses

CONNECTING MODULE	ADDRESS RANGE		PERIPHERAL SELECTS
	BASE ADDRESS	ENDING ADDRESS	
SYSTEM	0xFFFF_FD00	0xFFFF_FFFF	N/A
RESERVED	0xFFF8_0000	0xFFFF_FCFF	N/A
HET	0xFFF7_FC00	0xFFF7_FFFF	PS[0]
SPI1	0xFFF7_F800	0xFFF7_FBFF	PS[1]
SCI2	0xFFF7_F500	0xFFF7_F7FF	PS[2]
SCI1	0xFFF7_F400	0xFFF7_F4FF	
ADC	0xFFF7_F000	0xFFF7_F3FF	PS[3]
GIO/ECP	0xFFF7_EC00	0xFFF7_EFFF	PS[4]
RESERVED	0xFFF7_E400	0xFFF7_EBFF	PS[5] – PS[6]
SCC	0xFFF7_E000	0xFFF7_E3FF	PS[7]
SCC RAM	0xFFF7_DC00	0xFFF7_DFFF	PS[8]
RESERVED	0xFFF7_D800	0xFFF7_DBFF	PS[9]
SPI2	0xFFF7_D400	0xFFF7_D7FF	PS[10]
RESERVED	0xFFF7_CC00	0xFFF7_D3FF	PS[11] – PS[12]
C2S1b	0xFFF7_C800	0xFFF7_CBFF	PS[13]
RESERVED	0xFFF7_C000	0xFFF7_C7FF	PS[14] – PS[15]
RESERVED	0xFFF0_0000	0xFFF7_BFFF	N/A
FLASH CONTROL REGISTERS	0xFFE8_8000	0xFFE8_BFFF	N/A
MPU CONTROL REGISTERS	0xFFE8_4000	0xFFE8_4023	N/A

Interrupt Priority

The central interrupt manager (CIM) portion of the SYS module manages the interrupt requests from the device modules (i.e., SPI1 or SPI2, SCI1 or SCI2, and RTI, etc.).

Although the CIM can accept up to 32 interrupt request signals, the A256 device only uses 21 of those interrupt request signals. The request channels are maskable so that individual channels can be selectively disabled. All interrupt requests can be programmed in the CIM to be of either type:

- Fast interrupt request (FIQ)
- Normal interrupt request (IRQ)

The precedences of request channels decrease with ascending channel order in the CIM (0 [highest] and 31 [lowest] priority). For these channel priorities and the associated modules, see [Table 5](#).

Table 5. Interrupt Priority

MODULES	INTERRUPT SOURCES	INTERRUPT LEVEL/CHANNEL
SPI1	SPI1 end-transfer/overrun	0
RTI	COMP2 interrupt	1
RTI	COMP1 interrupt	2
RTI	TAP interrupt	3
SPI2	SPI2 end-transfer/overrun	4
GIO	Interrupt A	5
RESERVED		6
HET	Interrupt 1	7
RESERVED		8
SCI1/SCI2	SCI1/SCI2 error interrupt	9
SCI1	SCI1 receive interrupt	10
C2Sib	C2Sib interrupt	11
RESERVED		12
RESERVED		13
SCC	Interrupt A	14
RESERVED		15
MibADC	End event conversion	16
SCI2	SCI2 receive interrupt	17
RESERVED		18
RESERVED		19
SCI1	SCI1 transmit interrupt	20
System	SW interrupt (SSI)	21
RESERVED		22
HET	Interrupt 2	23
RESERVED		24
SCC	Interrupt B	25
SCI2	SCI2 transmit interrupt	26
MibADC	End Group 1 conversion	27
RESERVED		28
GIO	Interrupt B	29
MibADC	End Group 2 conversion	30
RESERVED		31

MibADC

The multi-buffered analog-to-digital converter (MibADC) accepts an analog signal and converts the signal to a 10-bit digital value.

The A256 MibADC module can function in two modes: compatibility mode, where its programmer's model is compatible with the TMS470R1x ADC module and its digital results are stored in digital result registers; or in buffered mode, where the digital result registers are replaced with three FIFO buffers, one for each conversion group (event, group1 [G1], and group2 [G2]). In buffered mode, the MibADC buffers can be serviced by interrupts.

MibADC event trigger enhancements

The MibADC includes two major enhancements over the event-triggering capability of the TMS470R1x ADC.

- Both group1 and the event group can be configured for event-triggered operation, providing up to two event-triggered groups.
- The trigger source and polarity can be selected individually for both group 1 and the event group from the three options identified in [Table 6](#).

Table 6. MibADC Event Hookup Configuration

EVENT #	SOURCE SELECT BITS for G1 or EVENT (G1SRC[1:0] or EVSRC[1:0])	SIGNAL PIN NAME
EVENT1	00	ADEVT
EVENT2	01	HET18
EVENT3	10	HET19
EVENT4	11	RESERVED

For group 1, these event-triggered selections are configured through the group 1 source select bits (G1SRC[1:0]) in the AD event source register (ADEVTSRC[5:4]). For the event group, these event-triggered selections are configured through the event group source select bits (EVSRC[1:0]) in the AD event source register (ADEVTSRC[1:0]).

For more detailed functional information on the MibADC, see the *TMS470R1x Multi-Buffered Analog-to-Digital Converter (MibADC) Reference Guide* (literature number SPNU206).

Documentation Support

Extensive documentation supports all of the TMS470 microcontroller family generation of devices. The types of documentation available include: data sheets with design specifications; complete user's guides; and errata sheets. Useful reference documentation includes:

- Bulletin
 - *TMS470 Microcontroller Family Product Bulletin* (literature number SPNB086)
- User's Guides
 - *TMS470R1x System Module Reference Guide* (literature number SPNU189)
 - *TMS470R1x General Purpose Input/Output (GPIO) Reference Guide* (literature number SPNU192)
 - *TMS470R1x Direct Memory Access (DMA) Controller Reference Guide* (literature number SPNU194)
 - *TMS470R1x Serial Peripheral Interface (SPI) Reference Guide* (literature number SPNU195)
 - *TMS470R1x Serial Communication Interface (SCI) Reference Guide* (literature number SPNU196)
 - *TMS470R1x Controller Area Network (CAN) Reference Guide* (literature number SPNU197)
 - *TMS470R1x High End Timer (HET) Reference Guide* (literature number SPNU199)
 - *TMS470R1x External Clock Prescale (ECP) Reference Guide* (literature number SPNU202)
 - *TMS470R1x MultiBuffered Analog to Digital (MibADC) Reference Guide* (literature number SPNU206)
 - *TMS470R1x ZeroPin Phase Locked Loop (ZPLL) Clock Module Reference Guide* (literature number SPNU212)
 - *TMS470R1x F05 Flash Reference Guide* (literature number SPNU213)
 - *TMS470R1x Class II Serial Interface B (C2SIb) Reference Guide* (literature number SPNU214)
 - *TMS470R1x Class II Serial Interface A (C2SIa) Reference Guide* (literature number SPNU218)
 - *TMS470R1x Inter-Integrated Circuit (I2C) Reference Guide* (literature number SPNU223)
 - *TMS470 Peripherals Overview Reference Guide* (literature number SPNU248)
- Errata Sheet:
 - *TMS470R1A256 TMS470 Microcontrollers Silicon Errata* (literature number SPNZ133)

Device and Development-Support Tool Nomenclature

To designate the stages in the product development cycle, TI assigns prefixes to the part numbers of all DSP devices and support tools. Each DSP commercial family member has one of three prefixes: TMX, TMP, or TMS (e.g., **TMS470R1A256**). Texas Instruments recommends two of three possible prefix designators for its support tools: TMDX and TMDS. These prefixes represent evolutionary stages of product development from engineering prototypes (TMX/TMDX) through fully qualified production devices/tools (TMS/TMDS).

Device development evolutionary flow:

TMX Experimental device that is not necessarily representative of the final device's electrical specifications

TMP Final silicon die that conforms to the device's electrical specifications but has not completed quality and reliability verification

TMS Fully qualified production device

Support tool development evolutionary flow:

TMDX Development-support product that has not yet completed Texas Instruments internal qualification testing.

TMDS Fully qualified development-support product

TMX and TMP devices and TMDX development-support tools are shipped against the following disclaimer:

"Developmental product is intended for internal evaluation purposes."

TMS devices and TMDS development-support tools have been characterized fully, and the quality and reliability of the device have been demonstrated fully. TI's standard warranty applies.

Predictions show that prototype devices (TMX or TMP) have a greater failure rate than the standard production devices. Texas Instruments recommends that these devices not be used in any production system because their expected end-use failure rate still is undefined. Only qualified production devices are to be used.

[Figure 2](#) illustrates the numbering and symbol nomenclature for the TMS470R1x family.

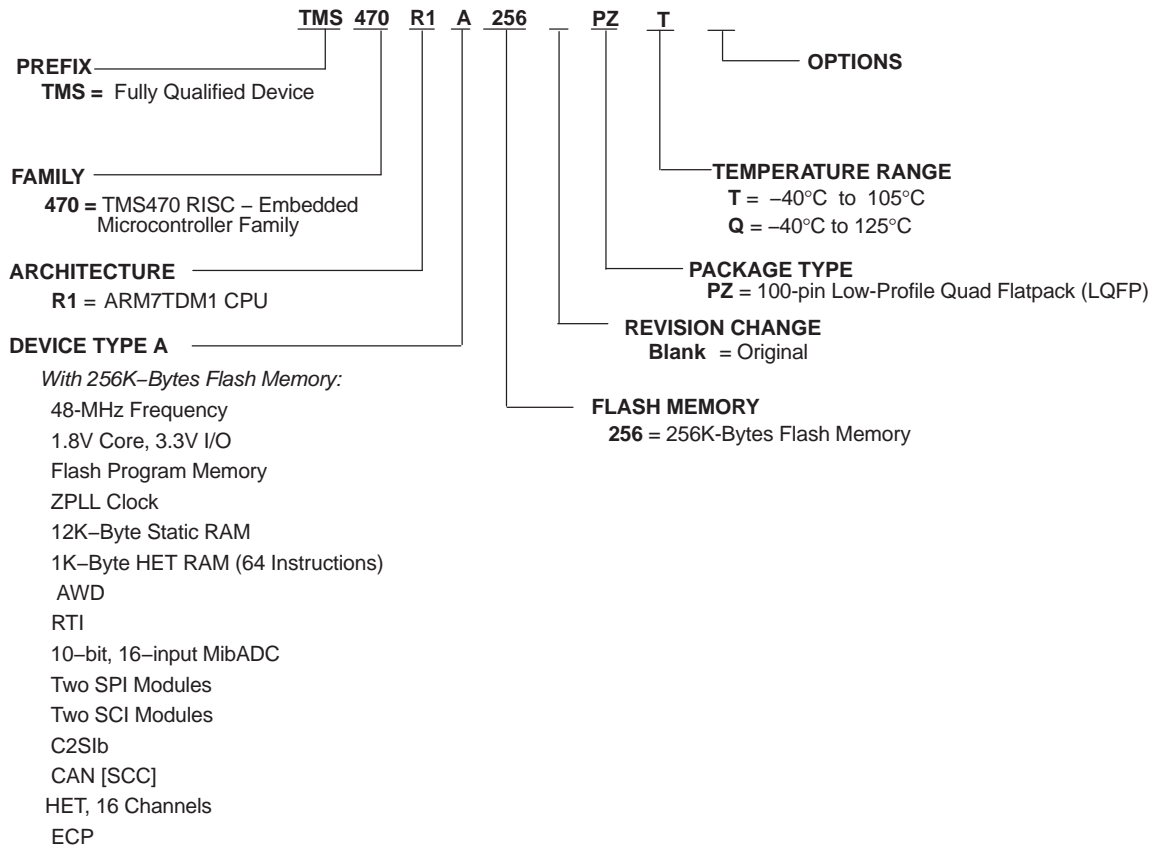
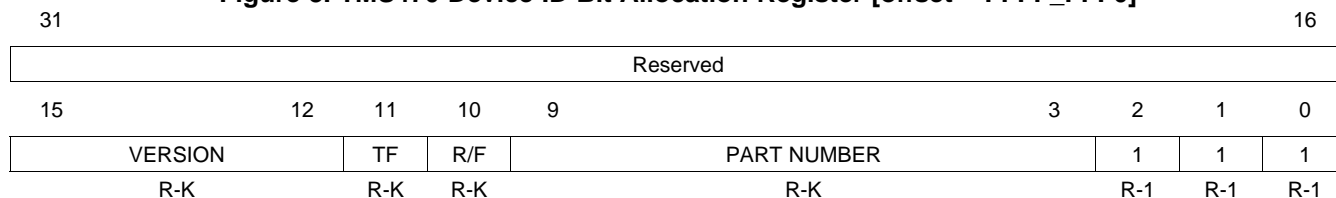

Figure 2. TMS470R1x Family Nomenclature

Device Identification Code Register

The device identification code register identifies the silicon version, the technology family (TF), a ROM or flash device, and an assigned device-specific part number (see [Figure 3](#)). The A256 device identification code register value is 0x0857.

Figure 3. TMS470 Device ID Bit Allocation Register [offset = FFFF_FFF0]



LEGEND: R = Read only; -K = value constant after $\overline{\text{RESET}}$; -n = value after $\overline{\text{RESET}}$

TMS470 Device ID Bit Allocation Register Description

BIT	NAME	Value	DESCRIPTION
31-16	Reserved		Reads are undefined and writes have no effect.
15-12	VERSION		Silicon version (revision) bits These bits identify what version of silicon the device is. Initial device version numbers start at 0000.
11	TF	0 1	Technology Family (TF) This bit distinguishes the technology family core power supply. 3.3 V for F10/C10 devices 1.8 V for F05/C05 devices
10	R/F	0 1	ROM/flash This bit distinguishes between ROM and flash devices: Flash device ROM device
9-3	PART NUMBER		Device-specific part number These bits identify the assigned device-specific part number. The assigned device-specific part number for the A256 device is 0001010.
2-0	1		Mandatory High Bits 2, 1, and 0 are tied high by default.

DEVICE ELECTRICAL SPECIFICATIONS AND TIMING PARAMETERS

Absolute Maximum Ratings

over operating free-air temperature range, T version (unless otherwise noted)⁽¹⁾

Supply voltage ranges:	V_{CC}, V_{CCF} ⁽²⁾	-0.3 V to 2.5
Supply voltage ranges:	$V_{CCIO}, V_{CCAD}, V_{CCP}$ (flash pump) ⁽²⁾	-0.3 V to 4.1V
Input voltage range:	All input pins	-0.3 V to 4.1
Input clamp current:	$I_{IK} (V_I < 0 \text{ or } V_I > V_{CCIO})$	
	All pins except ADIN[0:15], \overline{PORRST} , \overline{TRST} , TEST and TCK	±20 mA
	$I_{IK} (V_I < 0 \text{ or } V_I > V_{CCAD})$	
	ADIN[0:11]	±10 mA
Operating free-air temperature ranges, T_A :	T version	-40°C to 105°C
	Q version	-40°C to 125°C
Operating junction temperature range, T_J		-40°C to 150°C
Storage temperature range, T_{stg}		-65°C to 150°C

(1) Stresses beyond those listed under "absolute maximum ratings" may cause permanent damage to the device. These are stress ratings only, and functional operation of the device at these or any other conditions beyond those indicated under "recommended operating conditions" is not implied. Exposure to absolute-maximum-rated conditions for extended periods may affect device reliability.

(2) All voltage values are with respect to their associated grounds.

Device Recommended Operating Conditions⁽¹⁾

			MIN	NOM	MAX	UNIT
V_{CC}	Digital logic and flash supply voltage (Core)		1.81		2.06	V
V_{CCIO}	Digital logic supply voltage (I/O)		3	3.3	3.6	V
V_{CCAD}	ADC supply voltage		3	3.3	3.6	V
V_{CCP}	Flash pump supply voltage		3	3.3	3.6	V
V_{SS}	Digital logic supply ground			0		V
V_{SSAD}	ADC supply ground		-0.1		0.1	V
T_A	Operating free-air temperature	T version	-40		105	°C
		Q version	-40		125	
T_J	Operating junction temperature		-40		150	°C

(1) All voltages are with respect to VSS, except VCCAD, which is with respect to VSSAD.

Electrical Characteristics over Recommended Operating Free-Air Temperature Range⁽¹⁾

PARAMETER		TEST CONDITIONS	MIN	TYP	MAX	UNIT
V _{hys}	Input hysteresis		0.15			V
V _{IL}	Low-level input voltage	All inputs ⁽²⁾ except OSCIN	-0.3		0.8	V
		OSCIN only	-0.3		0.35 V _{CC}	
V _{IH}	High-level input voltage	All inputs except OSCIN	2		V _{CCIO} + 0.3	V
		OSCIN only	0.65 V _{CC}		V _{CC} + 0.3	
V _{th}	Input threshold voltage	AWD only	1.35		1.8	V
RDS _{ON}	Drain to source on resistance	AWD only ⁽³⁾	VOL = 0.35 V @ I _{OL} = 8mA		45	Ω
V _{OL}	Low-level output voltage ⁽⁴⁾	I _{OL} = I _{OL} MAX			0.2 V _{CCIO}	V
		I _{OL} = 50 μA			0.2	
V _{OH}	High-level output voltage ⁽⁴⁾	I _{OH} = I _{OH} MIN	0.8 V _{CCIO}			V
		I _{OH} = 50 μA	V _{CCIO} - 0.2			
I _{IC}	Input clamp current (I/O pins) ⁽⁵⁾	V _I < V _{SSIO} - 0.3 or V _I > V _{CCIO} + 0.3	-2		2	mA
I _I	Input current (I/O pins)	I _{IL} Pulldown	V _I = V _{SS}	-1	1	μA
		I _{IH} Pulldown	V _I = V _{CCIO}	5	40	
		I _{IL} Pullup	V _I = V _{SS}	-40	-5	
		I _{IH} Pullup	V _I = V _{CCIO}	-1	1	
		All other pins	No pullup or pulldown	-1	1	
I _{OL}	Low-level output current	CLKOUT, AWD, TDO	V _{OL} = V _{OL} MAX		8	mA
		RST, SPI1CLK, SPI1SIMO, SPI1SOMI, SPI2CLK, SPI2SIMO, SPI2SOMI	V _{OL} = V _{OL} MAX		4	
		All other output pins ⁽⁶⁾	V _{OL} = V _{OL} MAX		2	
I _{OH}	High-level output current	CLKOUT, TDO	V _{OH} = V _{OH} MIN	-8		mA
		SPI1CLK, SPI1SIMO, SPI1SOMI, SPI2CLK, SPI2SIMO, SPI2SOMI	V _{OH} = V _{OH} MIN	-4		
		All other output pins ⁽⁶⁾	V _{OH} = V _{OH} MIN	-2		
I _{CC}	V _{CC} digital supply current (operating mode)	SYSCLK = 48 MHz, ICLK = 24 MHz, V _{CC} = 2.06 V			70	mA
		SYSCLK = 24 MHz, ICLK = 12 MHz, V _{CC} = 2.06 V			50	mA
	V _{CC} digital supply current (standby mode) ⁽⁷⁾	OSCIN = 6 MHz, V _{CC} = 2.06 V			3.0	mA
	V _{CC} digital supply current (halt mode) ⁽⁷⁾	All frequencies, V _{CC} = 2.06 V			1.0	mA

- (1) Source currents (out of the device) are negative while sink currents (into the device) are positive.
- (2) This does not apply to the PORRST pin. For PORRST exceptions, see the RST and PORRST timings section.
- (3) These values help to determine the external RC network circuit. For more details, see the *TMS470R1x System Module Reference Guide* (literature number SPNU189).
- (4) V_{OL} and V_{OH} are linear with respect to the amount of load current (I_{OL}/I_{OH}) applied.
- (5) Parameter does not apply to input-only or output-only pins.
- (6) The 2 mA buffers on this device are called zero-dominant buffers. If two of these buffers are shorted together and one is outputting a low level and the other is outputting a high level, the resulting value will always be low.
- (7) For flash pumps/banks in sleep mode.

Electrical Characteristics over Recommended Operating Free-Air Temperature Range (continued)

PARAMETER		TEST CONDITIONS	MIN	TYP	MAX	UNIT
I _{CCIO}	V _{CCIO} digital supply current (operating mode)	No DC load, V _{CCIO} = 3.6 V ⁽⁸⁾			10	mA
	V _{CCIO} digital supply current (standby mode)	No DC load, V _{CCIO} = 3.6 V ⁽⁸⁾			300	μA
	V _{CCIO} digital supply current (halt mode)	No DC load, V _{CCIO} = 3.6 V ⁽⁸⁾			300	μA
I _{CCAD}	V _{CCAD} supply current (operating mode)	All frequencies, V _{CCAD} = 3.6 V			15	mA
	V _{CCAD} supply current (standby mode)	All frequencies, V _{CCAD} = 3.6 V			20	μA
	V _{CCAD} supply current (halt mode)	All frequencies, V _{CCAD} = 3.6 V			20	μA
I _{CCP}	V _{CCP} pump supply current	V _{CCP} = 3.6 V read operation			45	mA
		V _{CCP} = 3.6 V program and erase			70	mA
		V _{CCP} = 3.6 V standby mode operation ⁽⁷⁾			20	μA
		V _{CCP} = 3.6 V halt mode operation ⁽⁷⁾			20	μA
C _I	Input capacitance			2		pF
C _O	Output capacitance			3		pF

(8) I/O pins configured as inputs or outputs with no load. All pulldown inputs ≥ 0.2 V. All pullup inputs ≥ V_{CCIO} - 0.2 V.

Parameter Measurement Information

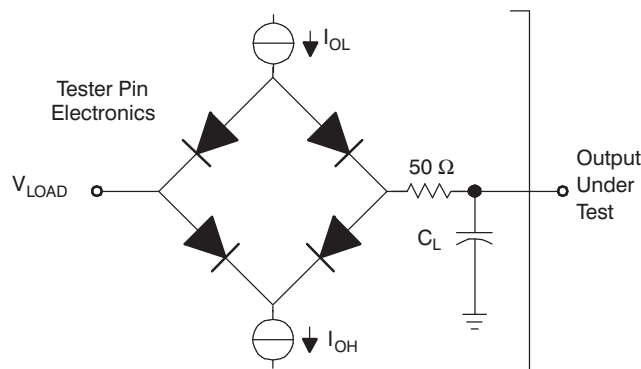

Where: I_{OL} = I_{OL} MAX for the respective pin^(A)
 I_{OH} = I_{OH} MIN for the respective pin^(A)
 V_{LOAD} = 1.5 V
 C_L = 150-pF typical load-circuit capacitance^(B)

- A. For these values, see the "Electrical Characteristics over Recommended Operating Free-Air Temperature Range" table.
- B. All timing parameters measured using an external load capacitance of 150 pF unless otherwise noted.

Figure 4. Test Load Circuit

Timing Parameter Symbology

Timing parameter symbols have been created in accordance with JEDEC Standard 100. To shorten the symbols, some of the pin names and other related terminology have been abbreviated as follows:

CM	Compaction, CMPCT	RD	Read
CO	CLKOUT	RST	Reset, $\overline{\text{RST}}$
ER	Erase	RX	SCInRX
ICLK	Interface clock	S	Slave mode
M	Master mode	SCC	SCInCLK
OSC, OSC1	OSCIN	SIMO	SPInSIMO
OSCO	OSCOOUT	SOMI	SPInSOMI
P	Program, PROG	SPC	SPInCLK
R	Ready	SYS	System clock
R0	Read margin 0, RDMRGN0	TX	SCInTX
R1	Read margin 1, RDMRGN1		

Lowercase subscripts and their meanings are:

a	access time	r	rise time
c	cycle time (period)	su	setup time
d	delay time	t	transition time
f	fall time	v	valid time
h	hold time	w	pulse duration (width)

The following additional letters are used with these meanings:

H	High	X	Unknown, changing, or don't care level
L	Low	Z	High impedance
V	Valid		

External Reference Resonator/Crystal Oscillator Clock Option

The oscillator is enabled by connecting the appropriate fundamental 4–20 MHz resonator/crystal and load capacitors across the external OSCIN and OSCOUT pins as shown in Figure 5a. The oscillator is a single-stage inverter held in bias by an integrated bias resistor. This resistor is disabled during leakage test measurement and HALT mode. **TI strongly encourages each customer to submit samples of the device to the resonator/crystal vendors for validation.** The vendors are equipped to determine what load capacitors will best tune their resonator/crystal to the microcontroller device for optimum start-up and operation over temperature/voltage extremes.

An external oscillator source can be used by connecting a 1.8-V clock signal to the OSCIN pin and leaving the OSCOUT pin unconnected (open) as shown in Figure 5b.

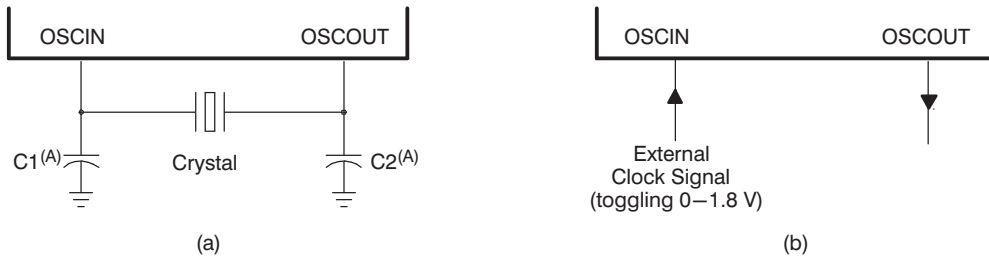

A. The values of C1 and C2 should be provided by the resonator/crystal vendor.

Figure 5. Crystal/Clock Connection

ZPLL AND CLOCK SPECIFICATIONS

Timing Requirements for ZPLL Circuits Enabled or Disabled

		MIN	MAX	UNIT
$f_{(OSC)}$	Input clock frequency	4	20	MHz
$t_{c(O SC)}$	Cycle time, OSCIN	50		ns
$t_{w(O SCIL)}$	Pulse duration, OSCIN low	15		ns
$t_{w(O SCIH)}$	Pulse duration, OSCIN high	15		ns
$f_{(OSCRST)}$	OSC FAIL frequency ⁽¹⁾		53	kHz

(1) Causes a device reset (specifically a clock reset) by setting the RST OSC FAIL (GLBCTRL.15) and the OSC FAIL flag (GLBSTAT.1) bits equal to 1. For more detailed information on these bits and device resets, see the *TMS470R1x System Module Reference Guide* (literature number SPNU189).

Switching Characteristics over Recommended Operating Conditions for Clocks⁽¹⁾⁽²⁾

PARAMETER		TEST CONDITION ⁽³⁾	MIN	MAX	UNIT
$f_{(SYS)}$	System clock frequency ⁽⁴⁾	Pipeline mode enabled		48	MHz
		Pipeline mode disabled		24	
$f_{(CONFIG)}$	System clock frequency - flash config mode			24	MHz
$f_{(ICLK)}$	Interface clock frequency	Pipeline mode enabled		25	MHz
		Pipeline mode disabled		24	
$f_{(ECLK)}$	External clock output frequency for ECP Module	Pipeline mode enabled		25	MHz
		Pipeline mode disabled		24	
$t_{c(SYS)}$	Cycle time, system clock	Pipeline mode enabled	20.8		ns
		Pipeline mode disabled	41.6		
$t_{c(CONFIG)}$	Cycle time, system clock - flash config mode		41.6		ns
$t_{c(ICLK)}$	Cycle time, interface clock	Pipeline mode enabled	40		ns
		Pipeline mode disabled	41.6		
$t_{c(ECLK)}$	Cycle time, ECP module external clock output	Pipeline mode enabled	40		ns
		Pipeline mode disabled	41.6		

(1) $f_{(SYS)} = M \times f_{(OSC)} / R$, where $M = \{4 \text{ or } 8\}$, $R = \{1, 2, 3, 4, 5, 6, 7, 8\}$ when PLLDIS = 0. R is the system-clock divider determined by the CLKDIVPRE [2:0] bits in the global control register (GLBCTRL[2:0]) and M is the PLL multiplier determined by the MULT4 bit, also in the GLBCTRL register (GLBCTRL.3).

$f_{(SYS)} = f_{(OSC)} / R$, where $R = \{1, 2, 3, 4, 5, 6, 7, 8\}$ when PLLDIS = 1.

$f_{(ICLK)} = f_{(SYS)} / X$, where $X = \{1, 2, 3, 4, 5, 6, 7, 8, 9, 10, 11, 12, 13, 14, 15, 16\}$. X is the interface clock divider ratio determined by the PCR0[4:1] bits in the SYS module.

(2) $f_{(ECLK)} = f_{(ICLK)} / N$, where $N = \{1 \text{ to } 256\}$. N is the ECP prescale value defined by the ECPCTRL[7:0] register bits in the ECP module

(3) Pipeline mode enabled or disabled is determined by the ENPIPE bit (FMREGOPT.0).

(4) Flash Vread must be set to 5 V to achieve maximum system clock frequency.

Switching Characteristics over Recommended Operating Conditions for External Clocks⁽¹⁾⁽²⁾⁽³⁾

(see Figure 6 and Figure 7)

PARAMETER	TEST CONDITION	MIN	MAX	UNIT
$t_{w(COL)}$	Pulse duration, CLKOUT low	SYSCLK or MCLK ⁽⁴⁾	$0.5t_{c(SYS)} - t_f$	ns
		ICLK, X is even or 1 ⁽⁵⁾	$0.5t_{c(ICK)} - t_f$	
		ICLK, X is odd and not 1 ⁽⁵⁾	$0.5t_{c(ICK)} + 0.5t_{c(SYS)} - t_f$	
$t_{w(COH)}$	Pulse duration, CLKOUT high	SYSCLK or MCLK ⁽⁴⁾	$0.5t_{c(SYS)} - t_f$	ns
		ICLK, X is even or 1 ⁽⁵⁾	$0.5t_{c(ICK)} - t_f$	
		ICLK, X is odd and not 1 ⁽⁵⁾	$0.5t_{c(ICK)} - 0.5t_{c(SYS)} - t_f$	
$t_{w(EOL)}$	Pulse duration, ECLK low	N is even and X is even or odd	$0.5t_{c(ECLK)} - t_f$	ns
		N is odd and X is even	$0.5t_{c(ECLK)} - t_f$	
		N is odd and X is odd and not 1	$0.5t_{c(ECLK)} + 0.5t_{c(SYS)} - t_f$	
$t_{w(EOH)}$	Pulse duration, ECLK high	N is even and X is even or odd	$0.5t_{c(ECLK)} - t_f$	ns
		N is odd and X is even	$0.5t_{c(ECLK)} - t_f$	
		N is odd and X is odd and not 1	$0.5t_{c(ECLK)} - 0.5t_{c(SYS)} - t_f$	

- (1) X = {1,2,3,4,5,6,7,8,9,10,11,12,13,14,15,16}. X is the interface clock divider ratio determined by the PCR0[4:1] bits in the SYS module.
- (2) N = {1 to 256}. N is the ECP prescale value defined by the ECPCTRL[7:0] register bits in the ECP module.
- (3) CLKOUT/ECLK pulse durations (low/high) are a function of the OSCIN pulse durations when PLLDIS is active.
- (4) Clock source bits selected as either SYSCLK (CLKCNTL[6:5] = 11 binary) or MCLK (CLKCNTL[6:5] = 10 binary).
- (5) Clock source bits selected as ICLK (CLKCNTL[6:5] = 01 binary).

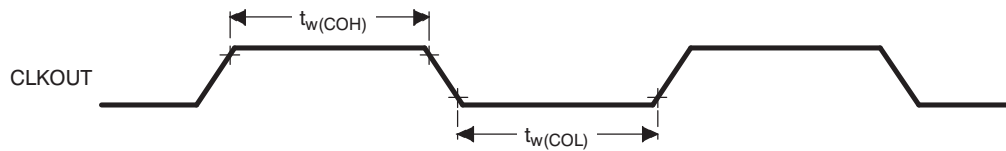

Figure 6. CLKOUT Timing Diagram

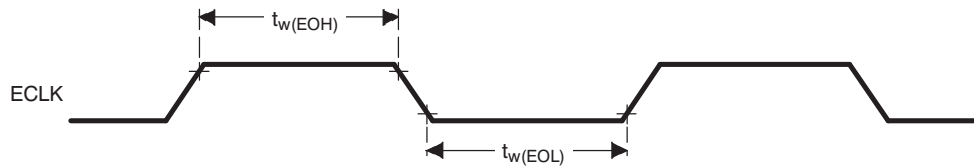

Figure 7. ECLK Timing Diagram

RST AND PORRST TIMINGS

Timing Requirements for PORRST

(see Figure 8)

		MIN	MAX	UNIT
V_{CCPORL}	V_{CC} low supply level when \overline{PORRST} must be active during power up		0.6	V
V_{CCPORH}	V_{CC} high supply level when \overline{PORRST} must remain active during power up and become active during power down	1.5		V
$V_{CCIOPORL}$	V_{CCIO} low supply level when \overline{PORRST} must be active during power up		1.1	V
$V_{CCIOPORH}$	V_{CCIO} high supply level when \overline{PORRST} must remain active during power up and become active during power down	2.75		V
V_{IL}	Low-level input voltage after $V_{CCIO} > V_{CCIOPORH}$		$0.2 V_{CCIO}$	V
$V_{IL(PORRST)}$	Low-level input voltage of \overline{PORRST} before $V_{CCIO} > V_{CCIOPORL}$		0.5	V
$t_{su(PORRST)r}$	Setup time, \overline{PORRST} active before $V_{CCIO} > V_{CCIOPORL}$ during power up	0		ms
$t_{su(VCCIO)r}$	Setup time, $V_{CCIO} > V_{CCIOPORL}$ before $V_{CC} > V_{CCPORL}$	0		ms
$t_{h(PORRST)r}$	Hold time, \overline{PORRST} active after $V_{CC} > V_{CCPORH}$	1		ms
$t_{su(PORRST)f}$	Setup time, \overline{PORRST} active before $V_{CC} \leq V_{CCPORH}$ during power down	8		ms
$t_{h(PORRST)rio}$	Hold time, \overline{PORRST} active after $V_{CC} > V_{CCIOPORH}$	1		ms
$t_{h(PORRST)d}$	Hold time, \overline{PORRST} active after $V_{CC} < V_{CCPORL}$	0		ms
$t_{su(PORRST)fo}$	Setup time, \overline{PORRST} active before $V_{CC} \leq V_{CCIOPORH}$ during power down	0		ms
$t_{su(VCCIO)f}$	Setup time, $V_{CC} < V_{CCPORL}$ before $V_{CCIO} < V_{CCIOPORL}$	0		ms

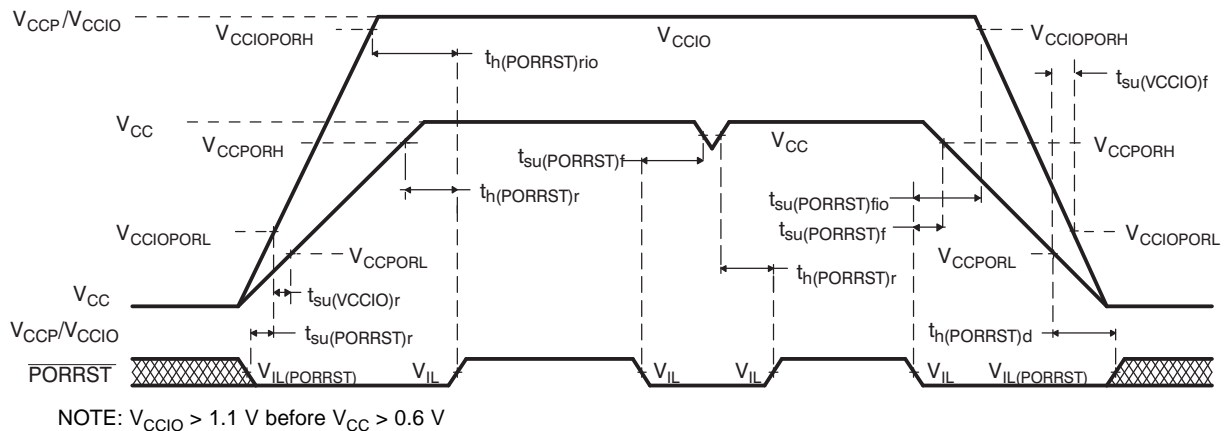

Figure 8. \overline{PORRST} Timing Diagram

Switching Characteristics over Recommended Operating Conditions for $\overline{RST}^{(1)}$

PARAMETER		MIN	MAX	UNIT
$t_{v(RST)}$	Valid time, \overline{RST} active after PORRST inactive	$4112t_{c(OSC)}$		ns
	Valid time, \overline{RST} active (all others)	$8t_{c(SYS)}$		
T_{fsu}	Flash start-up time, from \overline{RST} inactive to fetch of first instruction from flash (flash pump stabilization time)	$456t_{c(OSC)}$		ns

(1) Specified values do NOT include rise/fall times. For rise and fall timings, see the "Switching Characteristics for Output Timings versus Load Capacitance" table.

JTAG SCAN INTERFACE TIMING

(JTAG clock specification 10-MHz and 50-pF load on TDO output) (see [Figure 9](#))

		MIN	MAX	UNIT
$t_{c(JTAG)}$	Cycle time, JTAG low and high period	50		ns
$t_{su(TDI/TMS - TCKr)}$	Setup time, TDI, TMS before TCK rise (TCKr)	15		ns
$t_{h(TCKr - TDI/TMS)}$	Hold time, TDI, TMS after TCKr	15		ns
$t_{h(TCKf - TDO)}$	Hold time, TDO after TCKf	10		ns
$t_{d(TCKf - TDO)}$	Delay time, TDO valid after TCK fall (TCKf)		45	ns

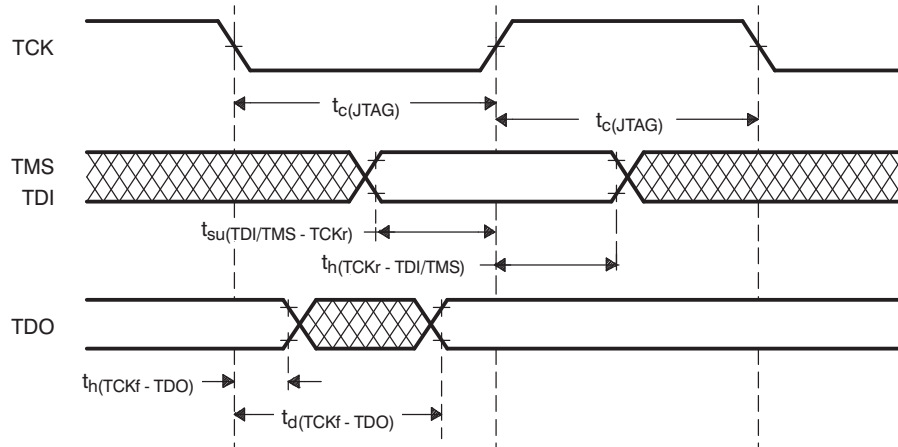

Figure 9. JTAG Scan Timings

OUTPUT TIMINGS

Switching Characteristics for Output Timings versus Load Capacitance (C_L)

(see Figure 10)

PARAMETER		MIN	MAX	UNIT	
t_r	Rise time, CLKOUT, AWD, TDO	$C_L = 15\text{ pF}$	0.5	2.50	ns
		$C_L = 50\text{ pF}$	1.5	5	
		$C_L = 100\text{ pF}$	3	9	
		$C_L = 150\text{ pF}$	4.5	12.5	
t_f	Fall time, CLKOUT, AWD, TDO	$C_L = 15\text{ pF}$	0.5	2.5	ns
		$C_L = 50\text{ pF}$	1.5	5	
		$C_L = 100\text{ pF}$	3	9	
		$C_L = 150\text{ pF}$	4.5	12.5	
t_r	Rise time, SPInCLK, SPInSOMI, SPInSIMO ⁽¹⁾	$C_L = 15\text{ pF}$	2.5	8	ns
		$C_L = 50\text{ pF}$	5	14	
		$C_L = 100\text{ pF}$	9	23	
		$C_L = 150\text{ pF}$	13	32	
t_f	Fall time, $\overline{\text{RST}}$, SPInCLK, SPInSOMI, SPInSIMO ⁽¹⁾	$C_L = 15\text{ pF}$	2.5	8	ns
		$C_L = 50\text{ pF}$	5	14	
		$C_L = 100\text{ pF}$	9	23	
		$C_L = 150\text{ pF}$	13	32	
t_r	Rise time, all other output pins	$C_L = 15\text{ pF}$	2.5	10	ns
		$C_L = 50\text{ pF}$	6.0	25	
		$C_L = 100\text{ pF}$	12	45	
		$C_L = 150\text{ pF}$	18	65	
t_f	Fall time, all other output pins	$C_L = 15\text{ pF}$	3	10	ns
		$C_L = 50\text{ pF}$	8.5	25	
		$C_L = 100\text{ pF}$	16	45	
		$C_L = 150\text{ pF}$	23	65	

(1) Where n = 1 and 2

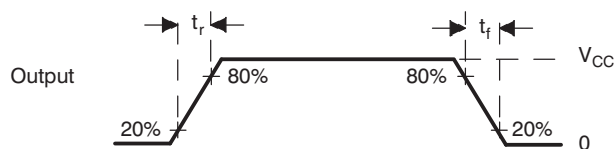

Figure 10. CMOS-Level Outputs

INPUT TIMINGS

Timing Requirements for Input Timings⁽¹⁾

(see Figure 11)

		MIN	MAX	UNIT
t_{pw}	Input minimum pulse width	$t_{c(ICKL)} + 10$		ns

(1) $t_{c(ICKL)}$ = interface clock cycle time = $1 / f_{(ICKL)}$

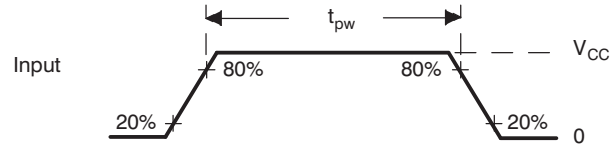

Figure 11. CMOS-Level Inputs

FLASH TIMINGS

Timing Requirements for Program Flash⁽¹⁾

		MIN	TYP	MAX	UNIT
$t_{prog(16-bit)}$	Half word (16-bit) programming time	4	16	200	μ s
$t_{prog(Total)}$	256K-byte programming time ⁽²⁾		2	8	s
$t_{erase(sector)}$	Sector erase time		1.7		s
t_{wec}	Write/erase cycles at $T_A = -40^\circ\text{C}$ to 125°C	50000			cycles
$t_{fp(\overline{RST})}$	Flash pump settling time from \overline{RST} to SLEEP		$167t_{c(SYS)}$		ns
$t_{fp(SLEEP)}$	Initial flash pump settling time from SLEEP to STANDBY		$167t_{c(SYS)}$		ns
$t_{fp(STANDBY)}$	Initial flash pump settling time from STANDBY to ACTIVE		$84t_{c(SYS)}$		ns

- (1) For more detailed information on the flash core sectors, see the flash program and erase section of this data sheet.
 (2) The 256K-byte programming times include overhead of state machine.

SPIn MASTER MODE TIMING PARAMETERS

SPIn Master Mode External Timing Parameters

(CLOCK PHASE = 0, SPInCLK = output, SPInSIMO = output, and SPInSOMI = input)⁽¹⁾⁽²⁾⁽³⁾ (see Figure 12)

NO.			MIN	MAX	UNIT
1	$t_{c(SPC)M}$	Cycle time, SPInCLK ⁽⁴⁾	100	$256t_{c(ICK)K}$	ns
2 ⁽⁵⁾	$t_{w(SPCH)M}$	Pulse duration, SPInCLK high (clock polarity = 0)	$0.5t_{c(SPC)M} - t_f$	$0.5t_{c(SPC)M} + 5$	ns
	$t_{w(SPCL)M}$	Pulse duration, SPInCLK low (clock polarity = 1)	$0.5t_{c(SPC)M} - t_f$	$0.5t_{c(SPC)M} + 5$	
3 ⁽⁵⁾	$t_{w(SPCL)M}$	Pulse duration, SPInCLK low (clock polarity = 0)	$0.5t_{c(SPC)M} - t_f$	$0.5t_{c(SPC)M} + 5$	ns
	$t_{w(SPCH)M}$	Pulse duration, SPInCLK high (clock polarity = 1)	$0.5t_{c(SPC)M} - t_f$	$0.5t_{c(SPC)M} + 5$	
4 ⁽⁵⁾	$t_{d(SPCH-SIMO)M}$	Delay time, SPInCLK high to SPInSIMO valid (clock polarity = 0)		10	ns
	$t_{d(SPCL-SIMO)M}$	Delay time, SPInCLK low to SPInSIMO valid (clock polarity = 1)		10	
5 ⁽⁵⁾	$t_{v(SPCL-SIMO)M}$	Valid time, SPInSIMO data valid after SPInCLK low (clock polarity = 0)	$t_{c(SPC)M} - 5 - t_f$		ns
	$t_{v(SPCH-SIMO)M}$	Valid time, SPInSIMO data valid after SPInCLK high (clock polarity = 1)	$t_{c(SPC)M} - 5 - t_f$		
6 ⁽⁵⁾	$t_{su(SOMI-SPCL)M}$	Setup time, SPInSOMI before SPInCLK low (clock polarity = 0)	6		ns
	$t_{su(SOMI-SPCH)M}$	Setup time, SPInSOMI before SPInCLK high (clock polarity = 1)	6		
7 ⁽⁵⁾	$t_{v(SPCL-SOMI)M}$	Valid time, SPInSOMI data valid after SPInCLK low (clock polarity = 0)	4		ns
	$t_{v(SPCH-SOMI)M}$	Valid time, SPInSOMI data valid after SPInCLK high (clock polarity = 1)	4		

- (1) The MASTER bit (SPInCTRL2.3) is set and the CLOCK PHASE bit (SPInCTRL2[1]) is cleared.
- (2) $t_{c(ICK)K}$ = interface clock cycle time = $1 / f_{(ICK)K}$
- (3) For rise and fall timings, see the "Switching Characteristics for Output Timings versus Load Capacitance" table.
- (4) When the SPI is in master mode, the following must be true:
For PS values from 1 to 255: $t_{c(SPC)M} \geq (PS + 1)t_{c(ICK)K} \geq 100$ ns, where PS is the prescale value set in the SPInCTL1[12:5] register bits.
For PS values of 0: $t_{c(SPC)M} = 2t_{c(ICK)K} \geq 100$ ns.
- (5) The active edge of the SPInCLK signal referenced is controlled by the CLOCK POLARITY bit (SPInCTRL2[1]).

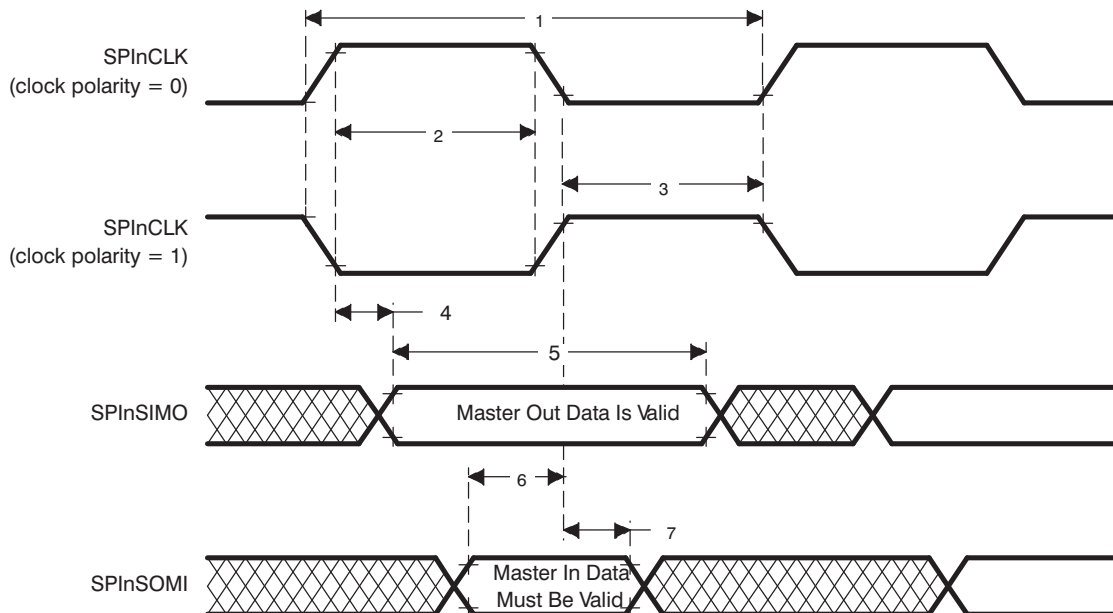

Figure 12. SPIn Master Mode External Timing (CLOCK PHASE = 0)

SPIn Master Mode External Timing Parameters

(CLOCK PHASE = 1, SPInCLK = output, SPInSIMO = output, and SPInSOMI = input)⁽¹⁾⁽²⁾⁽³⁾ (see Figure 13)

NO.			MIN	MAX	UNIT
1	$t_{c(SPC)M}$	Cycle time, SPInCLK ⁽⁴⁾	100	$256t_{c(I)CLK}$	ns
2 ⁽⁵⁾	$t_{w(SPCH)M}$	Pulse duration, SPInCLK high (clock polarity = 0)	$0.5t_{c(SPC)M} - t_f$	$0.5t_{c(SPC)M} + 5$	ns
	$t_{w(SPCL)M}$	Pulse duration, SPInCLK low (clock polarity = 1)	$0.5t_{c(SPC)M} - t_f$	$0.5t_{c(SPC)M} + 5$	
3 ⁽⁵⁾	$t_{w(SPCL)M}$	Pulse duration, SPInCLK low (clock polarity = 0)	$0.5t_{c(SPC)M} - t_f$	$0.5t_{c(SPC)M} + 5$	ns
	$t_{w(SPCH)M}$	Pulse duration, SPInCLK high (clock polarity = 1)	$0.5t_{c(SPC)M} - t_f$	$0.5t_{c(SPC)M} + 5$	
4 ⁽⁵⁾	$t_{v(SIMO-SPCH)M}$	Valid time, SPInCLK high after SPInSIMO data valid (clock polarity = 0)	$0.5t_{c(SPC)M} - 10$		ns
	$t_{v(SIMO-SPCL)M}$	Valid time, SPInCLK low after SPInSIMO data valid (clock polarity = 1)	$0.5t_{c(SPC)M} - 10$		
5 ⁽⁶⁾	$t_{v(SPCH-SIMO)M}$	Valid time, SPInSIMO data valid after SPInCLK high (clock polarity = 0)	$t_{c(SPC)M} - 5 - t_f$		ns
	$t_{v(SPCL-SIMO)M}$	Valid time, SPInSIMO data valid after SPInCLK low (clock polarity = 1)	$t_{c(SPC)M} - 5 - t_f$		
6 ⁽⁶⁾	$t_{su(SOMI-SPCH)M}$	Setup time, SPInSOMI before SPInCLK high (clock polarity = 0)	6		ns
	$t_{su(SOMI-SPCL)M}$	Setup time, SPInSOMI before SPInCLK low (clock polarity = 1)	6		
7 ⁽⁵⁾	$t_{v(SPCH-SOMI)M}$	Valid time, SPInSOMI data valid after SPInCLK high (clock polarity = 0)	4		ns
	$t_{v(SPCL-SOMI)M}$	Valid time, SPInSOMI data valid after SPInCLK low (clock polarity = 1)	4		

- (1) The MASTER bit (SPInCTRL2.3) is set and the CLOCK PHASE bit (SPInCTRL2[1]) is set.
- (2) $t_{c(I)CLK}$ = interface clock cycle time = $1 / f_{(I)CLK}$
- (3) For rise and fall timings, see the "Switching Characteristics for Output Timings versus Load Capacitance" table.
- (4) When the SPI is in master mode, the following must be true:
For PS values from 1 to 255: $t_{c(SPC)M} \geq (PS + 1)t_{c(I)CLK} \geq 100$ ns, where PS is the prescale value set in the SPInCTL1[12:5] register bits.
For PS values of 0: $t_{c(SPC)M} = 2t_{c(I)CLK} \geq 100$ ns.
- (5) The active edge of the SPInCLK signal referenced is controlled by the CLOCK POLARITY bit (SPInCTRL2[1]).
- (6) The active edge of the SPInCLK signal referenced is controlled by the CLOCK POLARITY bit (SPInCTRL2[1]).

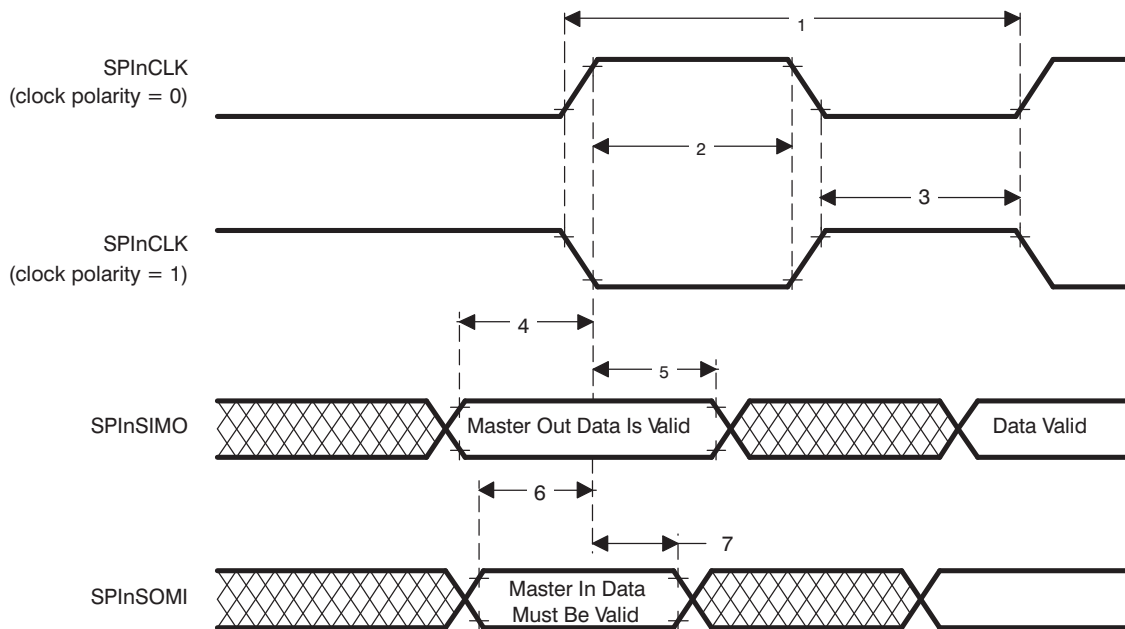

Figure 13. SPIn Master Mode External Timing (CLOCK PHASE = 1)

SPI Slave Mode Timing Parameters

SPI Slave Mode External Timing Parameters

(CLOCK PHASE = 0, SPInCLK = input, SPInSIMO = input, and SPInSOMI = output)⁽¹⁾⁽²⁾⁽³⁾⁽⁴⁾ (see Figure 14)

NO.			MIN	MAX	UNIT
1	$t_{c(SPC)}S$	Cycle time, SPInCLK ⁽⁵⁾	100	$256t_{c(ICLK)}$	ns
2 ⁽⁶⁾	$t_{w(SPCH)}S$	Pulse duration, SPInCLK high (clock polarity = 0)	$0.5t_{c(SPC)}S - 0.25t_{c(ICLK)}$	$0.5t_{c(SPC)}S + 0.25t_{c(ICLK)}$	ns
	$t_{w(SPCL)}S$	Pulse duration, SPInCLK low (clock polarity = 1)	$0.5t_{c(SPC)}S - 0.25t_{c(ICLK)}$	$0.5t_{c(SPC)}S + 0.25t_{c(ICLK)}$	
3 ⁽⁶⁾	$t_{w(SPCL)}S$	Pulse duration, SPInCLK low (clock polarity = 0)	$0.5t_{c(SPC)}S - 0.25t_{c(ICLK)}$	$0.5t_{c(SPC)}S + 0.25t_{c(ICLK)}$	ns
	$t_{w(SPCH)}S$	Pulse duration, SPInCLK high (clock polarity = 1)	$0.5t_{c(SPC)}S - 0.25t_{c(ICLK)}$	$0.5t_{c(SPC)}S + 0.25t_{c(ICLK)}$	
4 ⁽⁶⁾	$t_{d(SPCH-SOMI)}S$	Delay time, SPInCLK high to SPInSOMI valid (clock polarity = 0)		$6 + t_f$	ns
	$t_{d(SPCL-SOMI)}S$	Delay time, SPInCLK low to SPInSOMI valid (clock polarity = 1)		$6 + t_f$	
5 ⁽⁶⁾	$t_{v(SPCH-SOMI)}S$	Valid time, SPInSOMI data valid after SPInCLK high (clock polarity = 0)	$t_{c(SPC)}S - 6 - t_r$		ns
	$t_{v(SPCL-SOMI)}S$	Valid time, SPInSOMI data valid after SPInCLK low (clock polarity = 1)	$t_{c(SPC)}S - 6 - t_f$		
6 ⁽⁶⁾	$t_{su(SIMO-SPCL)}S$	Setup time, SPInSIMO before SPInCLK low (clock polarity = 0)	6		ns
	$t_{su(SIMO-SPCH)}S$	Setup time, SPInSIMO before SPInCLK high (clock polarity = 1)	6		
7 ⁽⁶⁾	$t_{v(SPCL-SIMO)}S$	Valid time, SPInSIMO data valid after SPInCLK low (clock polarity = 0)	6		ns
	$t_{v(SPCH-SIMO)}S$	Valid time, SPInSIMO data valid after SPInCLK high (clock polarity = 1)	6		

- (1) The MASTER bit (SPInCTRL2.3) is cleared and the CLOCK PHASE bit (SPInCTRL2[1]) is cleared.
- (2) If the SPI is in slave mode, the following must be true: $t_{c(SPC)}S \geq (PS + 1)t_{c(ICLK)}$, where PS = prescale value set in SPInCTL1[12:5].
- (3) For rise and fall timings, see the "Switching Characteristics for Output Timings versus Load Capacitance" table.
- (4) $t_{c(ICLK)}$ = interface clock cycle time = $1/f_{(ICLK)}$
- (5) When the SPIn is in slave mode, the following must be true:
 For PS values from 1 to 255: $t_{c(SPC)}S \geq (PS + 1)t_{c(ICLK)} \geq 100$ ns, where PS is the prescale value set in the SPInCTL1[12:5] register bits.
 For PS values of 0: $t_{c(SPC)}S = 2t_{c(ICLK)} \geq 100$ ns.
- (6) The active edge of the SPInCLK signal referenced is controlled by the CLOCK POLARITY bit (SPInCTRL2[1]).

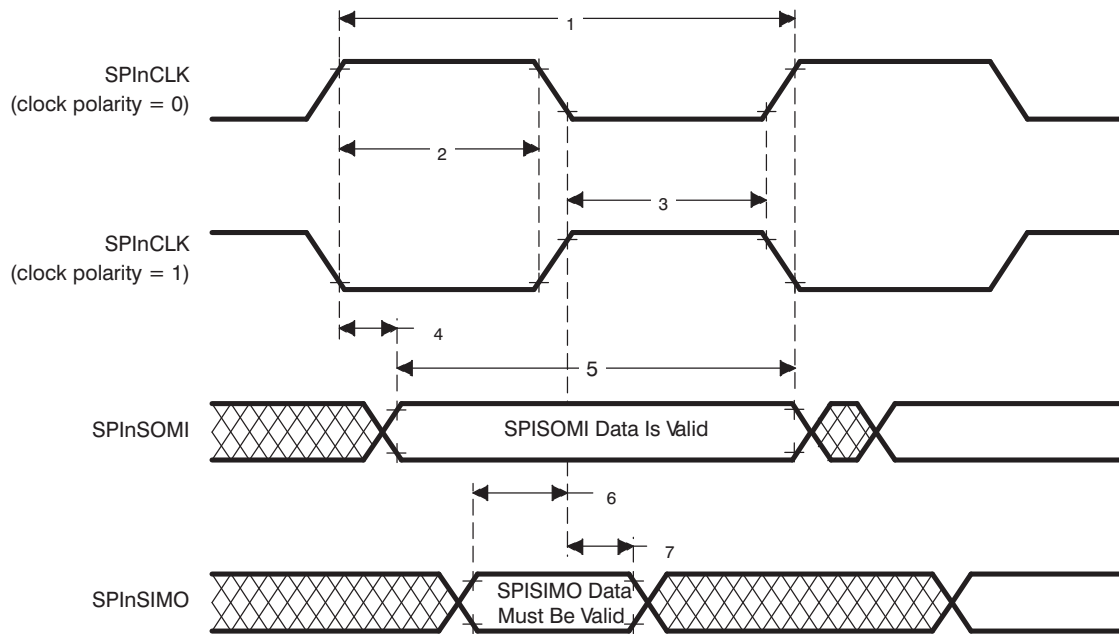

Figure 14. SPIn Slave Mode External Timing (CLOCK PHASE = 0)

SPI Slave Mode External Timing Parameters

(CLOCK PHASE = 1, SPInCLK = input, SPInSIMO = input, and SPInSOMI = output)⁽¹⁾⁽²⁾⁽³⁾⁽⁴⁾ (see Figure 15)

NO.			MIN	MAX	UNIT
1	$t_{c(SPC)S}$	Cycle time, SPInCLK ⁽⁵⁾	100	$256t_{c(ICLK)}$	ns
2 ⁽⁶⁾	$t_{w(SPCH)S}$	Pulse duration, SPInCLK high (clock polarity = 0)	$0.5t_{c(SPC)S} - 0.25t_{c(ICLK)}$	$0.5t_{c(SPC)S} + 0.25t_{c(ICLK)}$	ns
	$t_{w(SPCL)S}$	Pulse duration, SPInCLK low (clock polarity = 1)	$0.5t_{c(SPC)S} - 0.25t_{c(ICLK)}$	$0.5t_{c(SPC)S} + 0.25t_{c(ICLK)}$	
3 ⁽⁶⁾	$t_{w(SPCL)S}$	Pulse duration, SPInCLK low (clock polarity = 0)	$0.5t_{c(SPC)S} - 0.25t_{c(ICLK)}$	$0.5t_{c(SPC)S} + 0.25t_{c(ICLK)}$	ns
	$t_{w(SPCH)S}$	Pulse duration, SPInCLK high (clock polarity = 1)	$0.5t_{c(SPC)S} - 0.25t_{c(ICLK)}$	$0.5t_{c(SPC)S} + 0.25t_{c(ICLK)}$	
4 ⁽⁶⁾	$t_{v(SOMI-SPCH)S}$	Valid time, SPInCLK high after SPInSOMI data valid (clock polarity = 0)	$0.5t_{c(SPC)S} - 6 - t_r$		ns
	$t_{v(SOMI-SPCL)S}$	Valid time, SPInCLK low after SPInSOMI data valid (clock polarity = 1)	$0.5t_{c(SPC)S} - 6 - t_f$		
5 ⁽⁶⁾	$t_{v(SPCH-SOMI)S}$	Valid time, SPInSOMI data valid after SPInCLK high (clock polarity = 0)	$0.5t_{c(SPC)S} - 6 - t_r$		ns
	$t_{v(SPCL-SOMI)S}$	Valid time, SPInSOMI data valid after SPInCLK low (clock polarity = 1)	$0.5t_{c(SPC)S} - 6 - t_f$		
6 ⁽⁶⁾	$t_{su(SIMO-SPCH)S}$	Setup time, SPInSIMO before SPInCLK high (clock polarity = 0)	6		ns
	$t_{su(SIMO-SPCL)S}$	Setup time, SPInSIMO before SPInCLK low (clock polarity = 1)	6		
7 ⁽⁶⁾	$t_{v(SPCH-SIMO)S}$	Valid time, SPInSIMO data valid after SPInCLK high (clock polarity = 0)	6		ns
	$t_{v(SPCL-SIMO)S}$	Valid time, SPInSIMO data valid after SPInCLK low (clock polarity = 1)	6		

(1) The MASTER bit (SPInCTRL2.3) is cleared and the CLOCK PHASE bit (SPInCTRL2[1]) is set.

(2) If the SPI is in slave mode, the following must be true: $t_{c(SPC)S} \geq (PS + 1) t_{c(ICLK)}$, where PS = prescale value set in SPInCTL1[12:5].

(3) For rise and fall timings, see the "Switching Characteristics for Output Timings versus Load Capacitance" table.

(4) $t_{c(ICLK)}$ = interface clock cycle time = $1 / f_{(ICLK)}$

(5) When the SPI is in slave mode, the following must be true:

For PS values from 1 to 255: $t_{c(SPC)S} \geq (PS + 1)t_{c(ICLK)} \geq 100$ ns, where PS is the prescale value set in the SPInCTL1[12:5] register bits.

For PS values of 0: $t_{c(SPC)S} = 2t_{c(ICLK)} \geq 100$ ns.

(6) The active edge of the SPInCLK signal referenced is controlled by the CLOCK POLARITY bit (SPInCTRL2[1]).

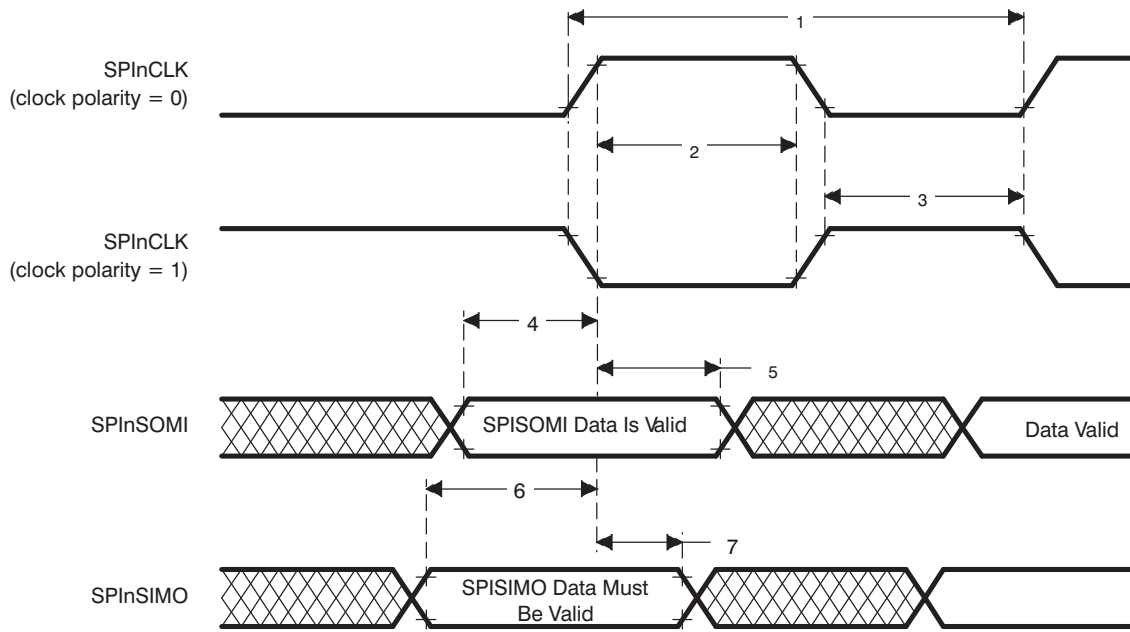

Figure 15. SPIn Slave Mode External Timing (CLOCK PHASE = 1)

SCI_n ISOSYNCHRONOUS MODE TIMINGS INTERNAL CLOCK

Timing Requirements for Internal Clock SCI_n Isosynchronous Mode⁽¹⁾⁽²⁾⁽³⁾

(see Figure 16)

		(BAUD + 1) IS EVEN OR BAUD = 0		(BAUD + 1) IS ODD AND BAUD ≠ 0		UNIT
		MIN	MAX	MIN	MAX	
$t_{c(SCC)}$	Cycle time, SCI _n CLK	$2t_{c(ICKL)}$	$2^{24}t_{c(ICKL)}$	$3t_{c(ICKL)}$	$(2^{24} - 1)t_{c(ICKL)}$	ns
$t_w(SCCL)$	Pulse duration, SCI _n CLK low	$0.5t_{c(SCC)} - t_f$	$0.5t_{c(SCC)} + 5$	$0.5t_{c(SCC)} + 0.5t_{c(ICKL)} - t_f$	$0.5t_{c(SCC)} + 0.5t_{c(ICKL)}$	ns
$t_w(SCCH)$	Pulse duration, SCI _n CLK high	$0.5t_{c(SCC)} - t_r$	$0.5t_{c(SCC)} + 5$	$0.5t_{c(SCC)} - 0.5t_{c(ICKL)} - t_r$	$0.5t_{c(SCC)} - 0.5t_{c(ICKL)}$	ns
$t_d(SCCH-TXV)$	Delay time, SCI _n CLK high to SCI _n TX valid		10		10	ns
$t_v(TX)$	Valid time, SCI _n TX data after SCI _n CLK low	$t_{c(SCC)} - 10$		$t_{c(SCC)} - 10$		ns
$t_{su}(RX-SCCL)$	Setup time, SCI _n RX before SCI _n CLK low	$t_{c(ICKL)} + t_f + 20$		$t_{c(ICKL)} + t_f + 20$		ns
$t_v(SCCL-RX)$	Valid time, SCI _n RX data after SCI _n CLK low	$-t_{c(ICKL)} + t_f + 20$		$-t_{c(ICKL)} + t_f + 20$		ns

(1) BAUD = 24-bit concatenated value formed by the SCI[H,M,L]BAUD registers.

(2) $t_{c(ICKL)}$ = interface clock cycle time = $1 / f_{(ICKL)}$

(3) For rise and fall timings, see the "Switching Characteristics for Output Timings versus Load Capacitance" table.

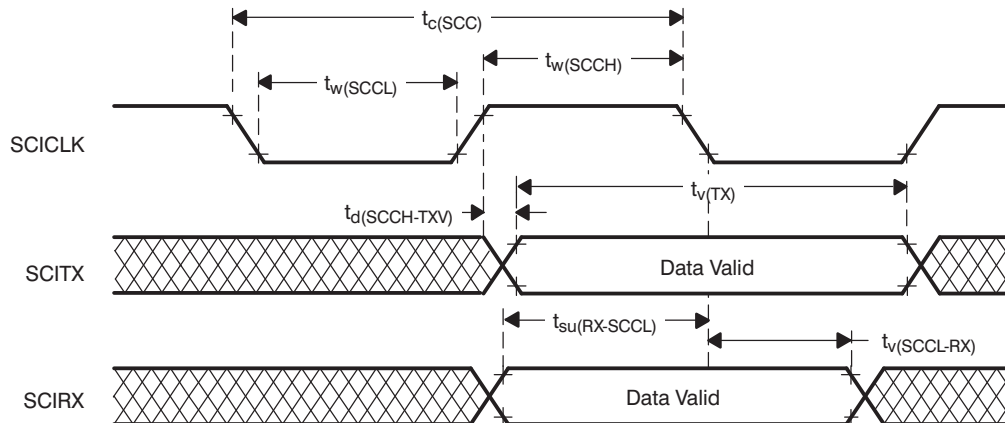

A. Data transmission/reception characteristics for isosynchronous mode with internal clocking are similar to the asynchronous mode. Data transmission occurs on the SCI_nCLK rising edge, and data reception occurs on the SCI_nCLK falling edge.

Figure 16. SCI_n Isosynchronous Mode Timing Diagram for Internal Clock

SCIn ISOSYNCHRONOUS MODE TIMINGS EXTERNAL CLOCK

Timing Requirements for External Clock SCIn Isosynchronous Mode⁽¹⁾⁽²⁾

(see Figure 17)

		MIN	MAX	UNIT
$t_{c(SCC)}$	Cycle time, SCInCLK ⁽³⁾	$8t_{c(ICLK)}$		ns
$t_w(SCCH)$	Pulse duration, SCInCLK high	$0.5t_{c(SCC)} - 0.25t_{c(ICLK)}$	$0.5t_{c(SCC)} + 0.25t_{c(ICLK)}$	ns
$t_w(SCCL)$	Pulse duration, SCInCLK low	$0.5t_{c(SCC)} - 0.25t_{c(ICLK)}$	$0.5t_{c(SCC)} + 0.25t_{c(ICLK)}$	ns
$t_d(SCCH-TXV)$	Delay time, SCInCLK high to SCInTX valid	$2t_{c(ICLK)} + 12 + t_r$		ns
$t_v(TX)$	Valid time, SCInTX data after SCInCLK low	$2t_{c(SCC)} - 10$		ns
$t_{su}(RX-SCCL)$	Setup time, SCInRX before SCInCLK low	0		ns
$t_v(SCCL-RX)$	Valid time, SCInRX data after SCInCLK low	$2t_{c(ICLK)} + 10$		ns

(1) $t_{c(ICLK)}$ = interface clock cycle time = $1 / f_{(ICLK)}$

(2) For rise and fall timings, see the "Switching Characteristics for Output Timings versus Load Capacitance" table.

(3) When driving an external SCInCLK, the following must be true: $t_{c(SCC)} \geq 8t_{c(ICLK)}$

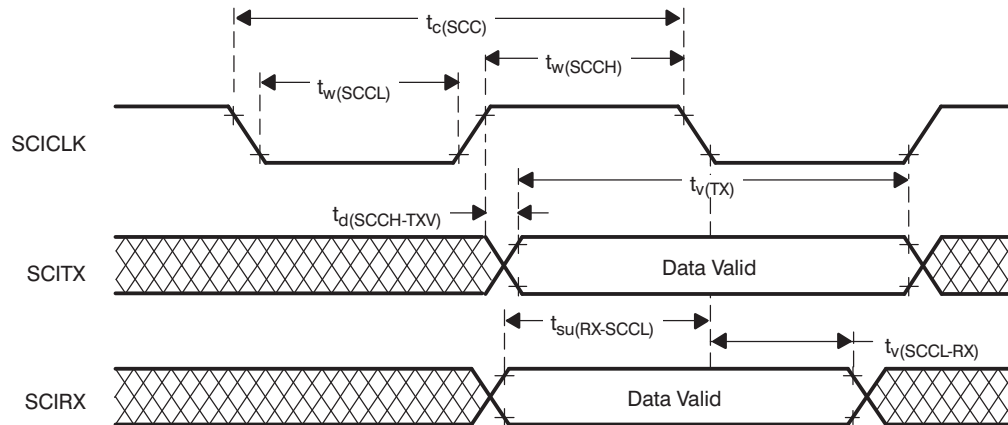

- A. Data transmission / reception characteristics for isosynchronous mode with external clocking are similar to the asynchronous mode. Data transmission occurs on the SCICLK rising edge, and data reception occurs on the SCICLK falling edge.

Figure 17. SCIn Isosynchronous Mode Timing Diagram for External Clock

HIGH-END TIMER (HET) TIMINGS

Minimum PWM Output Pulse Width:

This is equal to one high resolution clock period (HRP). The HRP is defined by the 6-bit high resolution prescale factor (hr), which is user defined, giving prescale factors of 1 to 64, with a linear increment of codes.

Therefore, the minimum PWM output pulse width = $HRP(\min) = hr(\min)/SYSCLK = 1/SYSCLK$

For example, for a SYSCLK of 30 MHz, the minimum PWM output pulse width = $1/30 = 33.33\text{ns}$

Minimum Input Pulses that Can Be Captured:

The input pulse width must be greater or equal to the low resolution clock period (LRP), i.e., the HET loop (the HET program must fit within the LRP). The LRP is defined by the 3-bit loop-resolution prescale factor (lr), which is user defined, with a power of 2 increment of codes. That is, the value of lr can be 1, 2, 4, 8, 16, or 32.

Therefore, the minimum input pulse width = $LRP(\min) = hr(\min) * lr(\min)/SYSCLK = 1 * 1/SYSCLK$

For example, with a SYSCLK of 30 MHz, the minimum input pulse width = $1 * 1/30 = 33.33 \text{ ns}$

NOTE:

Once the input pulse width is greater than LRP, the resolution of the measurement is still HRP. (That is, the captured value gives the number of HRP clocks inside the pulse.)

Abbreviations:

hr = HET high resolution divide rate = 1, 2, 3,...63, 64

lr = HET low resolution divide rate = 1, 2, 4, 8, 16, 32

High resolution clock period = $HRP = hr/SYSCLK$

Loop resolution clock period = $LRP = hr*lr/SYSCLK$

STANDARD CAN CONTROLLER (SCC) MODE TIMINGS

Dynamic Characteristics for the CANSTX and CANSRX Pins

PARAMETER		MIN	MAX	UNIT
$t_d(\text{CANSTX})$	Delay time, transmit shift register to CANSTX pin ⁽¹⁾		15	ns
$t_d(\text{CANSRX})$	Delay time, CANSRX pin to receive shift register		5	ns

(1) These values do not include the rise/fall times of the output buffer.

MULTI-BUFFERED A-TO-D CONVERTER (MibADC)

The multi-buffered A-to-D converter (MibADC) has a separate power bus for its analog circuitry. This power bus enhances the A-to-D performance by preventing digital switching noise on the logic circuitry which could be present on VSS and VCC from coupling into the A-to-D analog stage. All A-to-D specifications are given with respect to ADREFLO unless otherwise noted.

Resolution	10 bits (1024 values)
Monotonic	Assured
Output conversion code	00h to 3FFh [00 for $V_{AI} \leq AD_{REFLO}$; 3FF for $V_{AI} \geq AD_{REFHI}$]

Table 17. MibADC Recommended Operating Conditions⁽¹⁾

		MIN	MAX	UNIT
AD _{REFHI}	A-to-D high-voltage reference source	V _{SSAD}	V _{CCAD}	V
AD _{REFLO}	A-to-D low-voltage reference source	V _{SSAD}	V _{CCAD}	V
V _{AI}	Analog input voltage	V _{SSAD} - 0.3	V _{CCAD} + 0.3	V
I _{AIC}	Analog input clamp current ⁽²⁾ (V _{AI} < V _{SSAD} - 0.3 or V _{AI} > V _{CCAD} + 0.3)	-2	2	mA

- (1) For V_{CCAD} and V_{SSAD} recommended operating conditions, see the "Device Recommended Operating Conditions" table.
 (2) Input currents into any ADC input channel outside the specified limits could affect conversion results of other channels.

Table 18. Operating Characteristics over Full Ranges of Recommended Operating Conditions⁽¹⁾⁽²⁾

PARAMETER		DESCRIPTION/CONDITIONS	MIN	TYP	MAX	UNIT
R _i	Analog input resistance	See Figure 18.		250	500	Ω
C _i	Analog input capacitance	See Figure 18.			10	pF
			Conversion			30
I _{AIL}	Analog input leakage current	See Figure 18.	-1		1	μA
I _{ADREFHI}	AD _{REFHI} input current	AD _{REFHI} = 3.6 V, AD _{REFLO} = V _{SSAD}			5	mA
CR	Conversion range over which specified accuracy is maintained	AD _{REFHI} - AD _{REFLO}	3		3.6	V
E _{DNL}	Differential nonlinearity error	Difference between the actual step width and the ideal value after offset correction. See Figure 19.			±2	LSB
E _{INL}	Integral nonlinearity error	Maximum deviation from the best straight line through the MibADC. MibADC transfer characteristics, excluding the quantization error after offset correction. See Figure 20.			±2	LSB
E _{TOT}	Total error/Absolute accuracy	Maximum value of the difference between an analog value and the ideal midstep value. See Figure 21.			±2	LSB

- (1) V_{CCIO} = V_{CCAD} = AD_{REFHI}
 (2) 1 LSB = (AD_{REFHI} - AD_{REFLO}) / 2¹⁰ for the MibADC

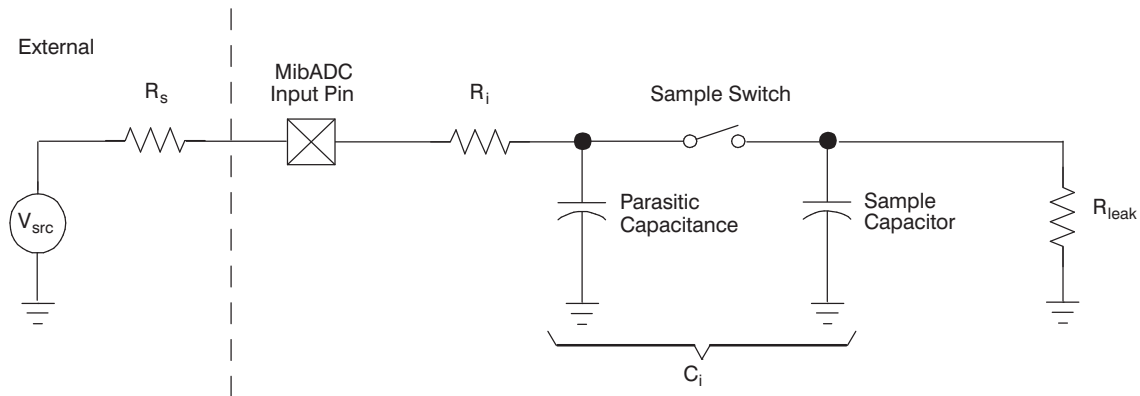

Figure 18. MibADC Input Equivalent Circuit

Table 19. Multi-Buffer ADC Timing Requirements

		MIN	MAX	UNIT
$t_{c(ADCLK)}$	Cycle time, MibADC clock	0.05		μs
$t_{d(SH)}$	Delay time, sample and hold time	1		μs
$t_{d(C)}$	Delay time, conversion time	0.55		μs
$t_{d(SHC)}^{(1)}$	Delay time, total sample/hold and conversion time	1.55		μs

(1) This is the minimum sample/hold and conversion time that can be achieved. These parameters are dependent on many factors for more detail; see the *TMS470R1x Multi-Buffered Analog-to-Digital Converter (MibADC) Reference Guide* (literature number SPNU206).

The differential nonlinearity error shown in Figure 19 (sometimes referred to as differential linearity) is the difference between an actual step width and the ideal value of 1 LSB.

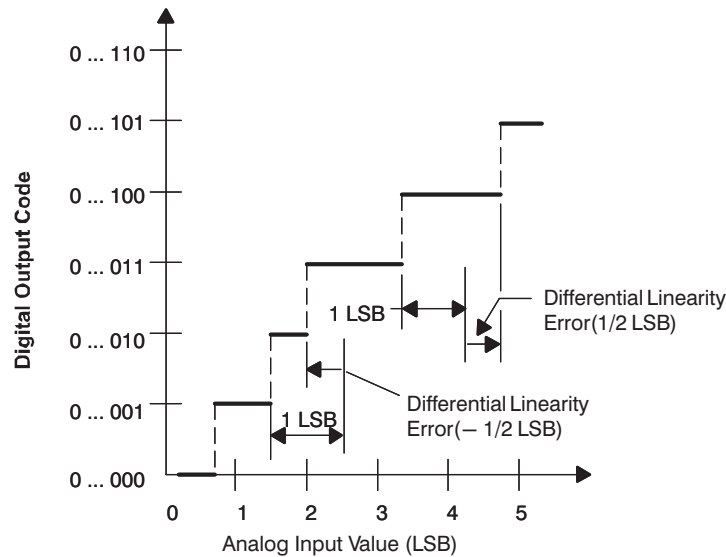

A. $1 \text{ LSB} = (AD_{REFHI} - AD_{REFLO})/2^{10}$

Figure 19. Differential Nonlinearity (DNL)

The integral nonlinearity error shown in Figure 20 (sometimes referred to as linearity error) is the deviation of the values on the actual transfer function from a straight line.

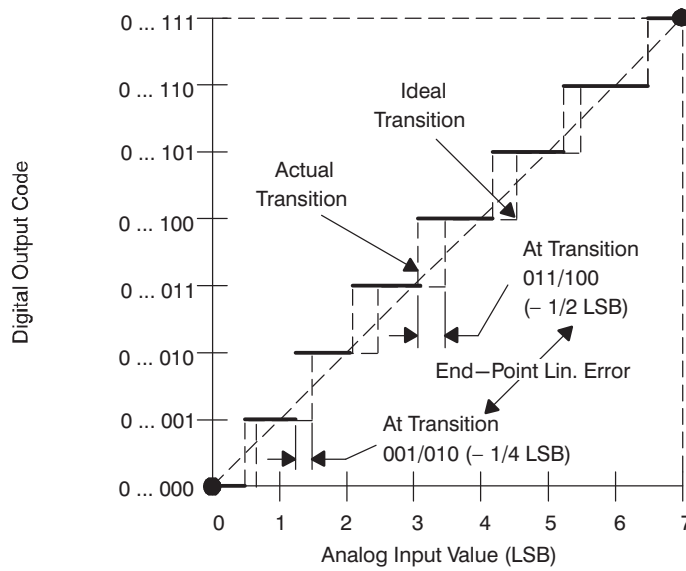

A. $1 \text{ LSB} = (AD_{\text{REFHI}} - AD_{\text{REFLO}})/2^{10}$

Figure 20. Integral Nonlinearity (INL) Error

The absolute accuracy or total error of an MibADC as shown in Figure 21 is the maximum value of the difference between an analog value and the ideal midstep value.

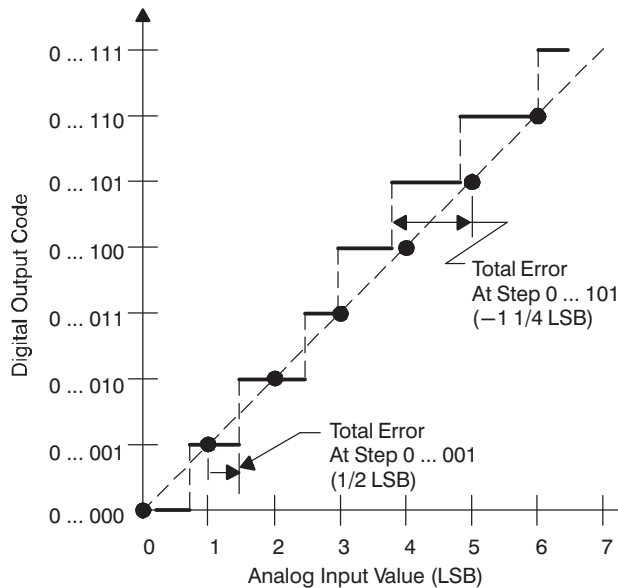

A. $1 \text{ LSB} = (AD_{\text{REFHI}} - AD_{\text{REFLO}})/2^{10}$

Figure 21. Absolute Accuracy (Total) Error

TMS470R1A256
16/32-Bit RISC Flash Microcontroller

SPNS100B–NOVEMBER 2004–REVISED AUGUST 2006

THERMAL CHARACTERISTICS

PARAMETER	°C/W
$R_{\theta JA}$	51
$R_{\theta JC}$	5

REVISION HISTORY

This revision history highlights the changes made to the device-specific datasheet SPNS100.

Table 7. Revision History

SPNS100A to SPNS100B
Revised the Family Nomenclature drawing, Figure 2 , to add Q version of the temperature range.
Revised "Absolute Maximum Ratings" table to add Q version of the temperature range.
Revised "Device Recommended Operating Conditions" table to add Q version of the temperature range.
Added note to $\overline{\text{PORRST}}$ Timing Diagram.
Changed T_A range to -40°C to 125°C on t_{wec} in "Timing Requirements for Program Flash" table.
Added t_{wec} MIN value of 50000 and deleted MAX value in "Timing Requirements for Program Flash" table.
Changed $t_{\text{erase(sector)}}$ TYP value to 1.7 and removed MAX value in "Timing Requirements for Program Flash" table.
SPNS100 to SPNS100A
Changed Figure 2 , the Family Nomenclature drawing, to reflect T version of the temperature range.
Revised "Absolute Maximum Ratings over Operating Free-Air Temperature Range" table to show T version of the temperature range.
Revised "Device Recommended Operating Conditions" table to show T version of the temperature range.
Added "Device and Development-Support Tool Nomenclature" information.
Changed VCC to 2.06 V in the ICC in the "Electrical Characteristics over Recommended Operating Free-Air Temperature Range" table.
Changed the max for the I_{CC} Digital supply current (operating mode) at SYSCLK = 48 MHz from 75 to 70 mA.
Corrected V_{CCP0RE} to V_{CCP0RL} in "Timing Requirements for $\overline{\text{PORRST}}$ " table.
Moved 2.75 from Max to Min column for V_{CCP0PORH} in "Timing Requirements for $\overline{\text{PORRST}}$ " table.
Added row for T_{fsu} to "Switching Characteristics over Recommended Operating Conditions for $\overline{\text{RST}}$ " table.
Added rows for $T_{\text{fp(RST)}}$, $T_{\text{fp(SLEEP)}}$, and $T_{\text{fp(STANDBY)}}$ to "Flash Timings" table.

PACKAGING INFORMATION

Orderable Device	Status (1)	Package Type	Package Drawing	Pins	Package Qty	Eco Plan (2)	Lead finish/ Ball material (6)	MSL Peak Temp (3)	Op Temp (°C)	Device Marking (4/5)	Samples
TMS470R1A256PZ-T	NRND	LQFP	PZ	100	90	RoHS & Green	NIPDAU	Level-3-260C-168 HR		470R1A256PZ-T TMS	

(1) The marketing status values are defined as follows:

ACTIVE: Product device recommended for new designs.

LIFEBUY: TI has announced that the device will be discontinued, and a lifetime-buy period is in effect.

NRND: Not recommended for new designs. Device is in production to support existing customers, but TI does not recommend using this part in a new design.

PREVIEW: Device has been announced but is not in production. Samples may or may not be available.

OBSOLETE: TI has discontinued the production of the device.

(2) **RoHS:** TI defines "RoHS" to mean semiconductor products that are compliant with the current EU RoHS requirements for all 10 RoHS substances, including the requirement that RoHS substance do not exceed 0.1% by weight in homogeneous materials. Where designed to be soldered at high temperatures, "RoHS" products are suitable for use in specified lead-free processes. TI may reference these types of products as "Pb-Free".

RoHS Exempt: TI defines "RoHS Exempt" to mean products that contain lead but are compliant with EU RoHS pursuant to a specific EU RoHS exemption.

Green: TI defines "Green" to mean the content of Chlorine (Cl) and Bromine (Br) based flame retardants meet JS709B low halogen requirements of <=100ppm threshold. Antimony trioxide based flame retardants must also meet the <=1000ppm threshold requirement.

(3) MSL, Peak Temp. - The Moisture Sensitivity Level rating according to the JEDEC industry standard classifications, and peak solder temperature.

(4) There may be additional marking, which relates to the logo, the lot trace code information, or the environmental category on the device.

(5) Multiple Device Markings will be inside parentheses. Only one Device Marking contained in parentheses and separated by a "~" will appear on a device. If a line is indented then it is a continuation of the previous line and the two combined represent the entire Device Marking for that device.

(6) Lead finish/Ball material - Orderable Devices may have multiple material finish options. Finish options are separated by a vertical ruled line. Lead finish/Ball material values may wrap to two lines if the finish value exceeds the maximum column width.

Important Information and Disclaimer:The information provided on this page represents TI's knowledge and belief as of the date that it is provided. TI bases its knowledge and belief on information provided by third parties, and makes no representation or warranty as to the accuracy of such information. Efforts are underway to better integrate information from third parties. TI has taken and continues to take reasonable steps to provide representative and accurate information but may not have conducted destructive testing or chemical analysis on incoming materials and chemicals. TI and TI suppliers consider certain information to be proprietary, and thus CAS numbers and other limited information may not be available for release.

In no event shall TI's liability arising out of such information exceed the total purchase price of the TI part(s) at issue in this document sold by TI to Customer on an annual basis.

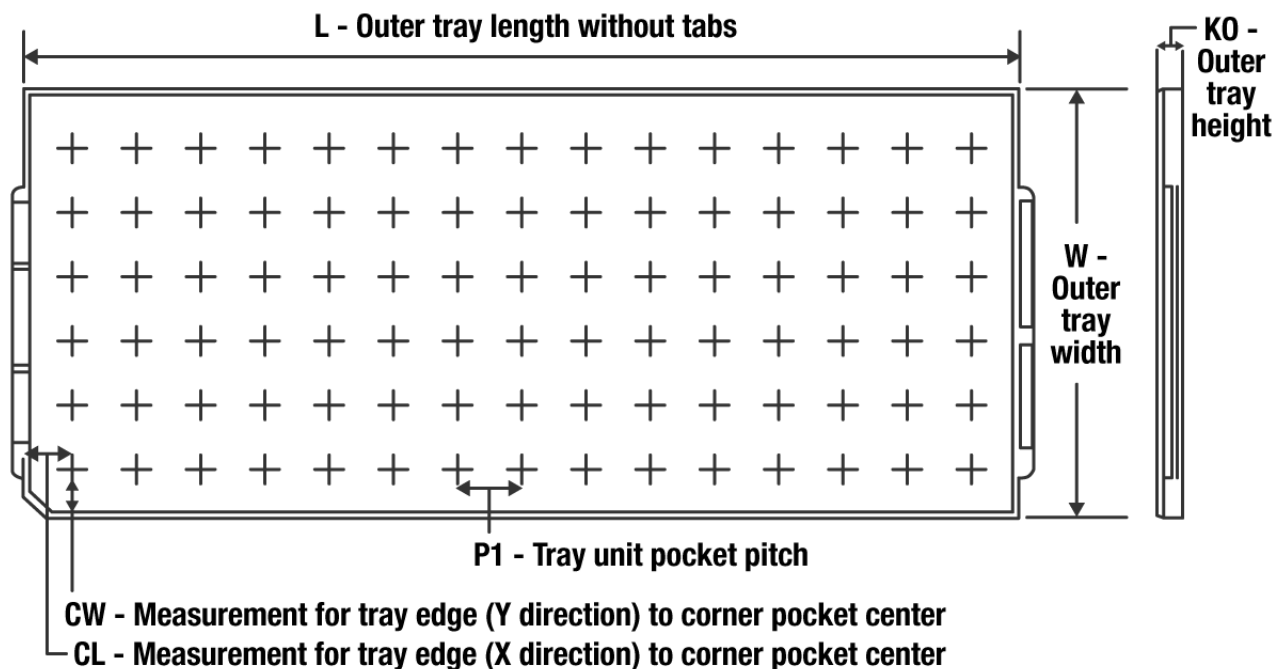
TRAY

Chamfer on Tray corner indicates Pin 1 orientation of packed units.

*All dimensions are nominal

Device	Package Name	Package Type	Pins	SPQ	Unit array matrix	Max temperature (°C)	L (mm)	W (mm)	K0 (µm)	P1 (mm)	CL (mm)	CW (mm)
TMS470R1A256PZ-T	PZ	LQFP	100	90	6 x 15	150	315	135.9	7620	20.3	15.4	15.4

PZ (S-PQFP-G100)

PLASTIC QUAD FLAT PACK

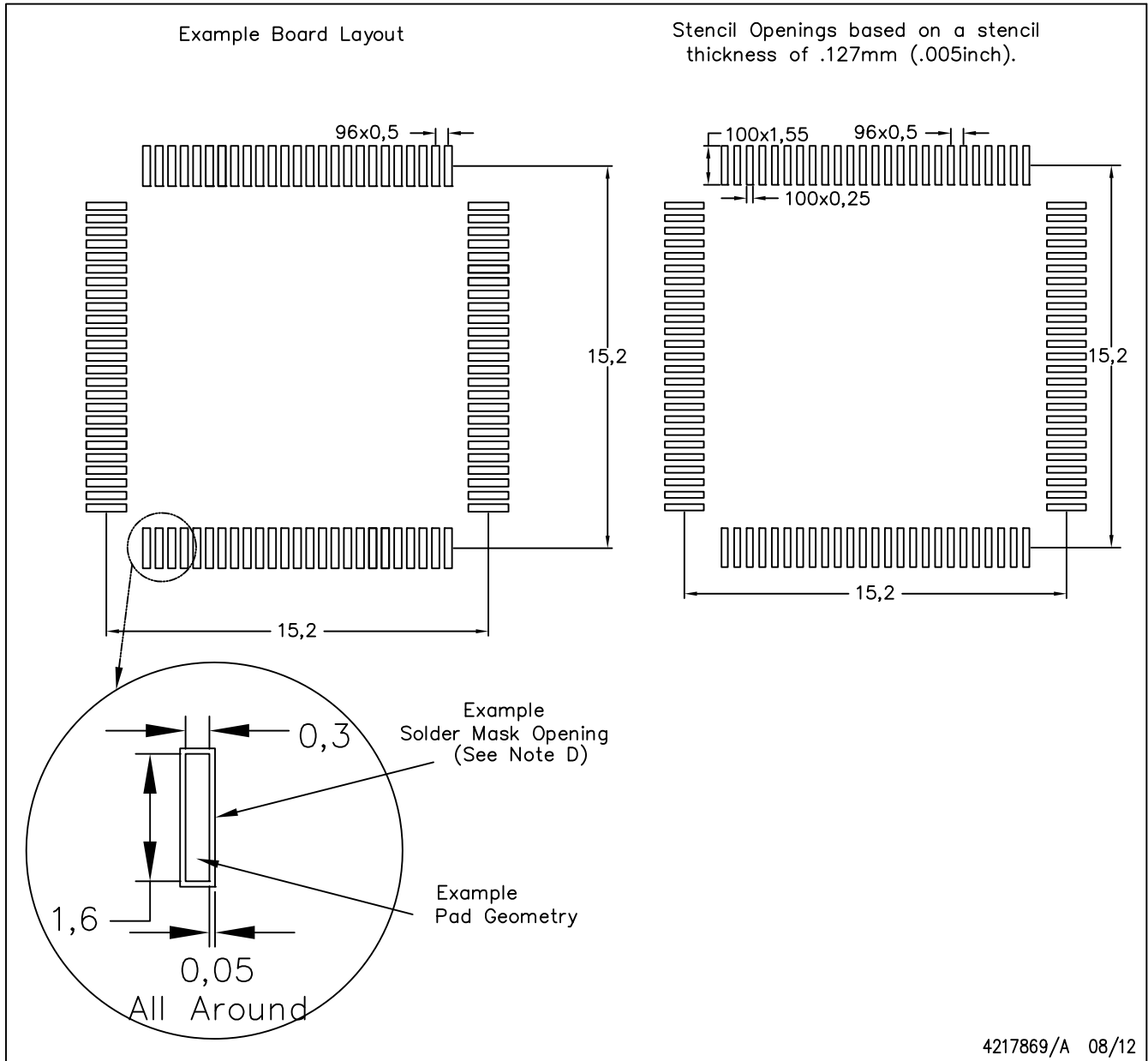

NOTES:

- A. All linear dimensions are in millimeters.
- B. This drawing is subject to change without notice.
- C. Laser cutting apertures with trapezoidal walls and also rounding corners will offer better paste release. Customers should contact their board assembly site for stencil design recommendations. Example stencil design based on a 50% volumetric metal load solder paste. Refer to IPC-7525 for other stencil recommendations.
- D. Customers should contact their board fabrication site for solder mask tolerances between and around signal pads.

IMPORTANT NOTICE AND DISCLAIMER

TI PROVIDES TECHNICAL AND RELIABILITY DATA (INCLUDING DATA SHEETS), DESIGN RESOURCES (INCLUDING REFERENCE DESIGNS), APPLICATION OR OTHER DESIGN ADVICE, WEB TOOLS, SAFETY INFORMATION, AND OTHER RESOURCES "AS IS" AND WITH ALL FAULTS, AND DISCLAIMS ALL WARRANTIES, EXPRESS AND IMPLIED, INCLUDING WITHOUT LIMITATION ANY IMPLIED WARRANTIES OF MERCHANTABILITY, FITNESS FOR A PARTICULAR PURPOSE OR NON-INFRINGEMENT OF THIRD PARTY INTELLECTUAL PROPERTY RIGHTS.

These resources are intended for skilled developers designing with TI products. You are solely responsible for (1) selecting the appropriate TI products for your application, (2) designing, validating and testing your application, and (3) ensuring your application meets applicable standards, and any other safety, security, regulatory or other requirements.

These resources are subject to change without notice. TI grants you permission to use these resources only for development of an application that uses the TI products described in the resource. Other reproduction and display of these resources is prohibited. No license is granted to any other TI intellectual property right or to any third party intellectual property right. TI disclaims responsibility for, and you will fully indemnify TI and its representatives against, any claims, damages, costs, losses, and liabilities arising out of your use of these resources.

TI's products are provided subject to [TI's Terms of Sale](#) or other applicable terms available either on ti.com or provided in conjunction with such TI products. TI's provision of these resources does not expand or otherwise alter TI's applicable warranties or warranty disclaimers for TI products.

TI objects to and rejects any additional or different terms you may have proposed.

Mailing Address: Texas Instruments, Post Office Box 655303, Dallas, Texas 75265
Copyright © 2022, Texas Instruments Incorporated

Looking for pricing, stock, or lifecycle information?

Click below to explore more details on WIN SOURCE:

 [View TMS470R1A256PZ-T on WIN SOURCE](#)

 [Texas Instruments](#) Information

Optimize Your Supply Chain with WIN SOURCE Solutions

-  Global Sourcing Solution
-  Obsolete Management
-  Cost Control Management
-  Shortage Management
-  Alternative Solution
-  Excess Inventory Management