



**THE DATASHEET OF
TMP86PH06UG(C,KJZ)**



CMOS 8-Bit Microcontroller

TMP86PH06N / TMP86PH06U

The TMP86PH06 is a OTP type MCU which includes 16 Kbyte One-time PROM. It is a pin compatible with a mask ROM product of the TMP86CH06. Writing the program to built-in PROM, the TMP86PH06 operates as the same way as the TMP86CH06. Using the Adapter socket, you can write and verify the data for the TMP86PH06 with a general-purpose PROM programmer same as TC57100D/AD.

Part No.	OTP	RAM	Package	Adapter Socket
TMP86PH06N	16 K × 8 bit	512 × 8 bit	P-SDIP42-600-1.78	BM11155
TMP86PH06U	16 K × 8 bit	512 × 8 bit	P-QFP44-1010-0.80	BM11156

P-SDIP42-600-1.78

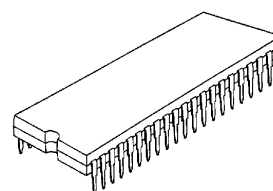

TMP86PH06N

P-QFP44-1010-0.80

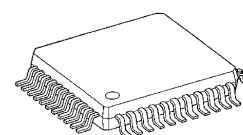

TMP86PH06U

980910EBP1

- For a discussion of how the reliability of microcontrollers can be predicted, please refer to Section 1.3 of the chapter entitled Quality and Reliability Assurance/Handling Precautions.
- TOSHIBA is continually working to improve the quality and the reliability of its products. Nevertheless, semiconductor devices in general can malfunction or fail due to their inherent electrical sensitivity and vulnerability to physical stress. It is the responsibility of the buyer, when utilizing TOSHIBA products, to observe standards of safety, and to avoid situations in which a malfunction or failure of a TOSHIBA product could cause loss of human life, bodily injury or damage to property. In developing your designs, please ensure that TOSHIBA products are used within specified operating ranges as set forth in the most recent products specifications. Also, please keep in mind the precautions and conditions set forth in the TOSHIBA Semiconductor Reliability Handbook.
- The products described in this document are subject to the foreign exchange and foreign trade laws.
- The information contained herein is presented only as a guide for the applications of our products. No responsibility is assumed by TOSHIBA CORPORATION for any infringements of intellectual property or other rights of the third parties which may result from its use. No license is granted by implication or otherwise under any intellectual property or other rights of TOSHIBA CORPORATION or others.
- The information contained herein is subject to change without notice.

Pin Assignments (Top View)

P-SDIP42-600-1.78

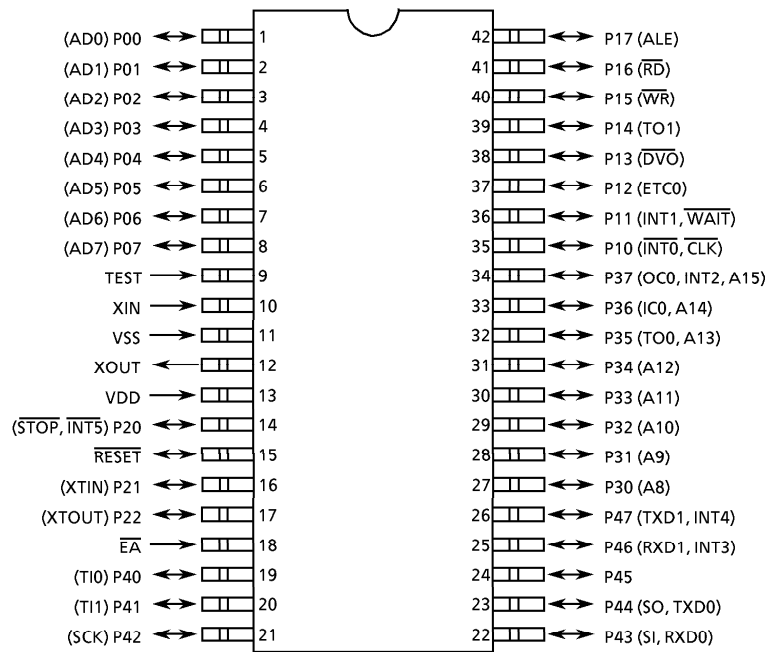

P-QFP44-1010-0.80

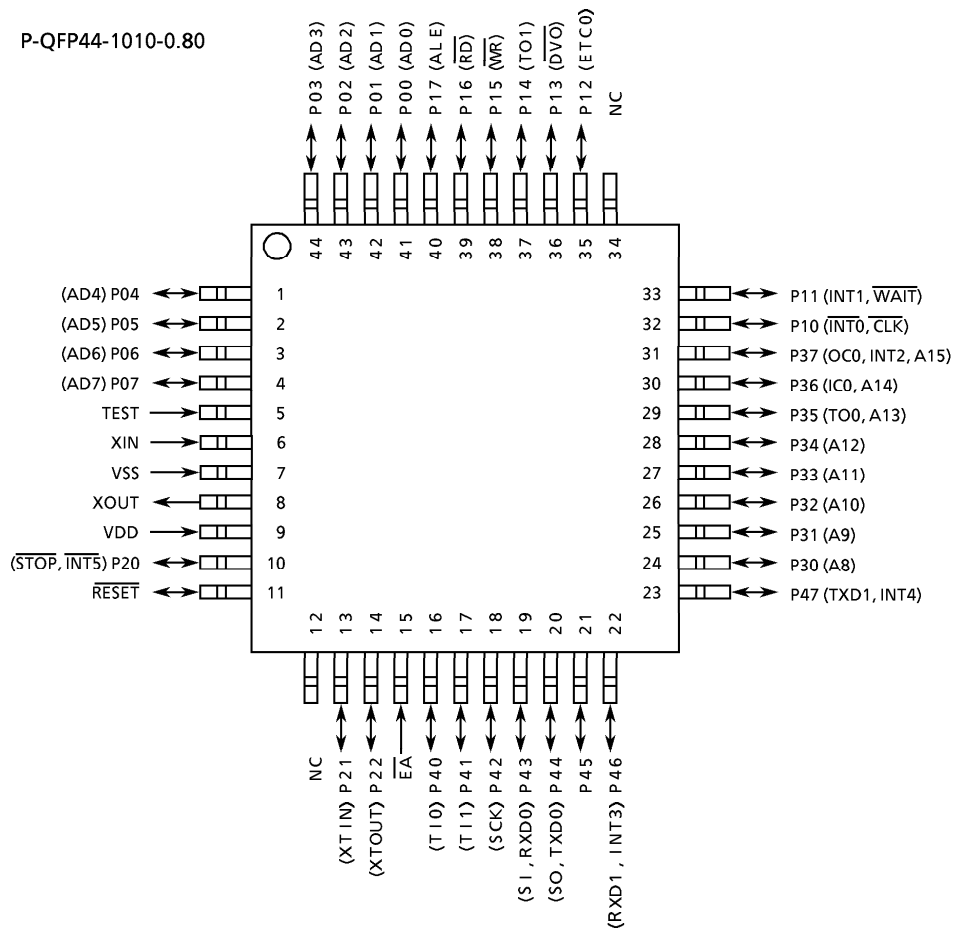

Pin Function

The TMP86PH06 has MCU mode and PROM mode.

(1) MCU mode

In the MCU mode, the TMP86PH06 is a pin compatible with the TMP86CH06 (Make sure to fix the TEST pin to low level).

(2) PROM mode

Pin Name (PROM mode)	Input/Output	Functions	Pin Name (MCU mode)
A15 to A8	Input	Input of Memory address for program	P30 to P37
A7 to A0			P40 to P47
D7 to D0	I/O	Input/Output of Memory data for program	P00 to P07
$\overline{\text{CE}}$	Input	Chip enable	P13
$\overline{\text{OE}}$		Output enable	P14
$\overline{\text{PGM}}$		Program control	P15
VPP	Power supply	+ 12.75 V / 5 V (Power supply of program)	TEST
VCC		+ 6.25 V / 5 V	VDD
GND		0 V	VSS
$\overline{\text{EA}}$, P11, P21	I/O	PROM mode setting pin. Fix to high.	
P12, P10, P22, P20		PROM mode setting pin. Fix to low.	
$\overline{\text{RESET}}$			
P16, P17	Output	Output pin for PROM operation test. Open or release.	
XIN	Input	Self oscillation with resonator (8 MHz).	
XOUT	Output		

Note: No pin is applied to A16 input.

Operational Description

This section describes the functions and basic operational blocks of TMP86PH06.

The TMP86PH06 has PROM in place of the mask ROM which is included in the TMP86CH06. The configuration and function are the same as the TMP86CH06. For the functions of TMP86PH06 in details, see the section of TMP86CH06.

In addition, TMP86PH06 operates as the single clock mode when releasing reset.

When using the dual clock mode, oscillate a low-frequency clock by SET. XTEN command at the beginning of program.

1. Operating Mode

The TMP86PH06 has MCU mode and PROM mode.

1.1 MCU mode

The MCU mode is set by fixing the TEST/VPP pin to the low level.

In the MCU mode, the operation is the same as the TMP86CH06 (TEST/VPP pin cannot be used open because it has no built-in pull-down resistor).

1.1.1 Program Memory

The TMP86PH06 has a 16-Kbyte built-in one time PROM (addresses C000 to 3FFF_H in the MCU mode, addresses 0000 to 3FFF_H in the PROM mode).

When using TMP86PH06 for evaluation of TMP86CH06, the program is written in the program storing area shown in Figure 1-1.

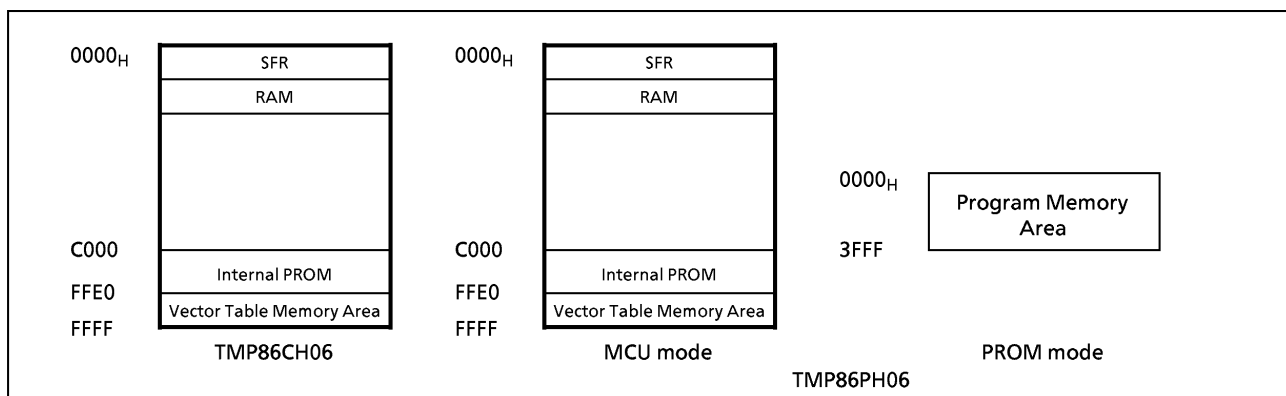

Figure 1-1. Program Memory Area

Note: The area that is not in use should be set data to FFH, or a general-purpose PROM programmer should be set only in the program memory area to access.

1.1.2 Data Memory

TMP86PH06 has a built-in 512-byte Data memory (static RAM).

1.1.3 Input/Output Circuitry

(1) Control pins

The control pins of the TMP86PH06 are the same as those of the TMP86CH06 except that the TEST pin does not have a built-in pull-down resistor.

(2) I/O ports

The I/O circuitries of TMP86PH06 I/O ports are the same as the those of TMP86CH06.

EPROM Adapter socket (TC571000 · 1MbitEPROM)

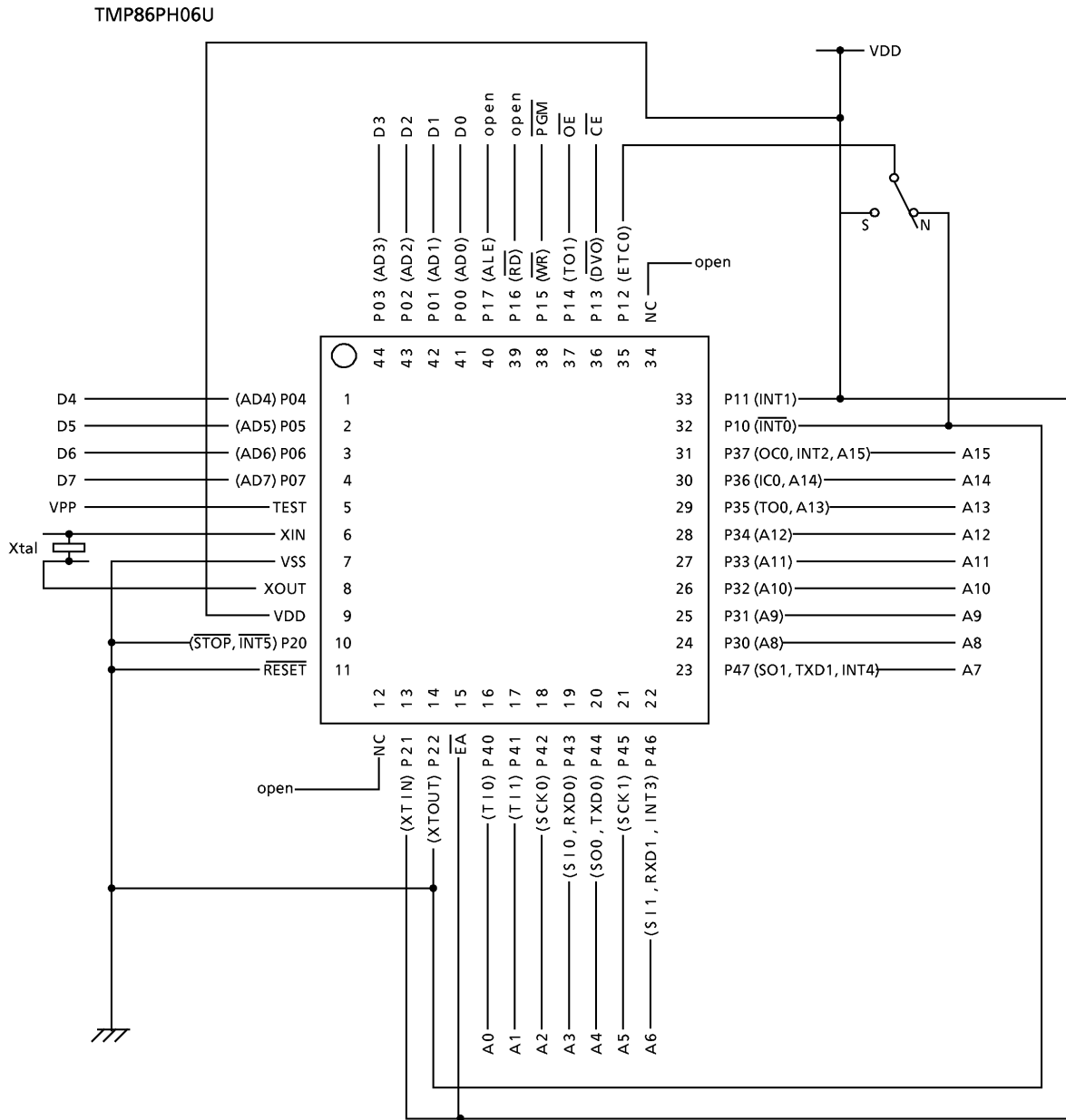

Inside pin name for 86PH06 (TOP VIEW)

Outside pin name for EPROM.

No pin is applied to A16 pin of TC571000 (open).

Figure 1-2 (b). PROM Mode Setting

1.2.1 Programming Flowchart (High-speed Program Writing)

The high-speed programming mode is set by applying 12.75 V (programming voltage) to the V_{PP} pin when the V_{CC} is 6.25 V. After the address and data are fixed, the data in the address is written by applying 0.1ms of low level program pulse to $\overline{\text{PGM}}$ pin. Then verify if the data is written.

If the programmed data is incorrect, another 0.1ms pulse is applied to $\overline{\text{PGM}}$ pin.

This programming procedure is repeated until correct data is read from the address (maximum of 25 times).

Subsequently, all data are programmed in all addresses.

When all data were written, verify all address under the condition of V_{CC} = V_{PP} = 5 V.

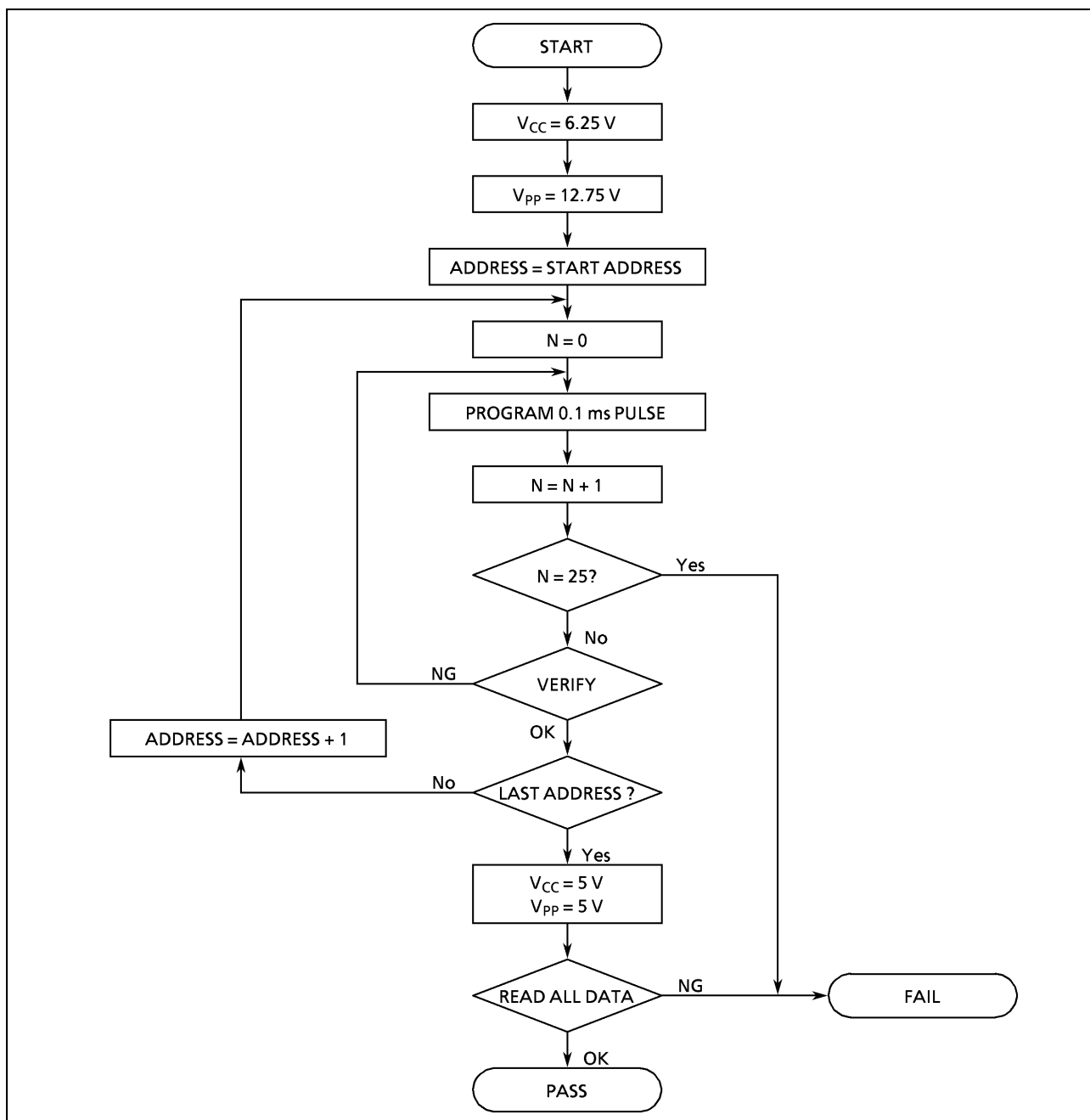

Figure 1-3. Programming Flow Chart

1.2.2 Program Writing using a general-purpose PROM programmer

(1) Recommended OTP Adapter

BM11155 : for TMP86PH06N

BM11156 : for TMP86PH06U

(2) Setting of OTP Adapter

Set the switch (SW1) to N side.

(3) Setting of PROM programmer

i) Set PROM type to TC571000D/AD.
VPP: 12.75 V (high-speed program writing)

ii) Data transmission (Note 1)

The PROM of TMP86PH06 is located on different addresses; it depends on operating modes: MCU mode and PROM mode. When you write the data of ROM for TMP86CH06, the data should be transferred from the address for MCU mode to that for PROM mode before writing operation is executed. For the applicable program areas of MCU mode and PROM mode are different, refer to Figure 1-1 Program Memory Area.

Example: Execute block Transferring on PROM programmer.

ROM (16 KB): 0C000 to 0FFFF_H → 00000 to 03FFF_H

iii) Setting of the program address (Note 1)

Start address: 00000_H

End address: 03FFF_H

(4) Writing program

Write and verify according to the above mentioned "Setting of PROM programmer."

Note 1: For the setting method, refer to each description of PROM programmer.

Make sure to set the data of address area that is not in used to FF_H.

Note 2: When setting MCU to the adapter or when setting the adapter to the PROM programmer, set the first pin of the adapter and that of PROM programmer socket matched. If the first pin is conversely set, MCU or adapter or programmer would be damaged.

Note 3: The TMP86PH06 does not support the electric signature mode.

If PROM programmer uses the signature, the device would be damaged because of applying voltage of 12 ± 0.5 V to pin 9 (A9) of the address.

Do not use the signature.

Electrical Characteristics

Absolute Maximum Rating

 $(V_{SS} = 0\text{ V})$

Parameter	Symbol	Pins	Rating	Unit
Supply Voltage	V_{DD}		- 0.3 to 6.5	V
Input Voltage	V_{IN}		- 0.3 to $V_{DD} + 0.3$	
Output Voltage	V_{OUT}		- 0.3 to $V_{DD} + 0.3$	
Output Current	I_{OUT1}	P1 to P4	3.2	mA
	I_{OUT3}	P0	30	
Output Current	ΣI_{OUT1}		80	
	ΣI_{OUT3}		120	
Power Dissipation ($T_{opr} = 85^\circ\text{C}$)	PD		330	mW
Soldering Temperature (Time)	T_{sld}		260 (10 s)	$^\circ\text{C}$
Storage Temperature	T_{stg}		- 55 to 125	
Operating Temperature	T_{opr}		- 40 to 85	

Note: The absolute maximum ratings are rated values which must not be exceeded during operation, even for an instant. Any one of the ratings must not be exceeded. If any absolute maximum rating is exceeded, a device may break down or its performance may be degraded, causing it to catch fire or explode resulting in injury to the user. Thus, when designing products which include this device, ensure that no absolute maximum rating value will ever be exceeded.

Recommended Operating Conditions

 $(V_{SS} = 0\text{ V}, T_{opr} = -40\text{ to }85^{\circ}\text{C})$

Parameter	Symbol	Pins	Conditions	Min	Max	Unit	
Supply Voltage	V_{DD}		$f_c = 16\text{ MHz}$	NORMAL1, 2 mode	4.5	5.5	V
				IDLE0, 1, 2 mode			
			$f_c = 4.2\text{ MHz}$	NORMAL1, 2 mode	1.8		
				IDLE0, 1, 2 mode			
			$f_s = 32.768\text{ kHz}$	SLOW1, 2 mode	1.8		
SLEEP0, 1, 2 mode							
	STOP mode	1.8					
Input High Voltage	V_{IH1}	Except hysteresis and TTL input	$V_{DD} \geq 4.5\text{ V}$	$V_{DD} \times 0.70$	V_{DD}	V	
	V_{IH2}	Hysteresis input		$V_{DD} \times 0.75$			
	V_{IH3}	Except TTL input	$V_{DD} < 4.5\text{ V}$	$V_{DD} \times 0.90$			
	V_{IH4}	TTL input (Data bus)	$V_{DD} = 5\text{ V}$	2.2			
	V_{IH5}		$V_{DD} = 3\text{ V}$	$V_{DD} - 0.2$			
Input Low Voltage	V_{IL1}	Except hysteresis and TTL input	$V_{DD} \geq 4.5\text{ V}$	0	$V_{DD} \times 0.30$	V	
	V_{IL2}	Hysteresis input			$V_{DD} \times 0.25$		
	V_{IL3}	Except TLL input	$V_{DD} < 4.5\text{ V}$		$V_{DD} \times 0.10$		
	V_{IL4}	TTL input (Data bus)	$V_{DD} = 5\text{ V}$		0.8		
			$V_{DD} = 3\text{ V}$		0.2		
V_{IL5}		$V_{DD} = 1.8\text{ V}$	TBD				
Clock Frequency	f_c	XIN, XOUT	$V_{DD} = 4.5\text{ V to }5.5\text{ V}$	1.0	16	MHz	
			$V_{DD} = 1.8\text{ V to }5.5\text{ V}$		4.2		
	f_s	XTIN, XTOUT		30.0	34.0	kHz	

Note 1: The recommended operating conditions for a device are operating conditions under which it can be guaranteed that the device will operate as specified. If the device is used under operating conditions other than the recommended operating conditions (supply voltage, operating temperature range, specified AC/DC values etc.), malfunction may occur. Thus, when designing products which include this device, ensure that the recommended operating conditions for the device are always adhered to.

Note 2: Clock Frequency f_c ; The condition of supply voltage range is the value under NORMAL and IDLE mode.

Note 3: The minimum f_c with clock gear is calculated as following formula with the ratio on divider n .

$$(\text{Min } f_c) = (\text{ratio on divider } n) \times 1 [\text{MHz}]$$

DC Characteristics

(V_{SS} = 0 V, T_{opr} = -40 to 85°C)

Parameter	Symbol	Pins	Conditions	Min	Typ.	Max	Unit
Hysteresis Voltage	V _{HS}	Hysteresis input		-	0.9	-	V
Input Current	I _{IN1}	TEST, \overline{EA}	V _{DD} = 5.5 V V _{IN} = 5.5 V / 0 V	-	-	± 2	μA
	I _{IN2}	Sink Open Drain, Tri-state Port					
	I _{IN3}	RESET, \overline{STOP}					
Input Resistance	R _{IN2}	RESET		100	220	450	kΩ
	R _{IN3}	TEST		-	70	-	
OSC. Feedback Resistance	R _{fx}	XIN-XOUT		-	1.2	-	MΩ
	R _{fxT}	XTIN-XTOUT		-	6	-	
Output Leakage Current	I _{LO1}	Sink Open Drain Port	V _{DD} = 5.5 V, V _{OUT} = 5.5 V	-	-	2	μA
	I _{LO2}	Tri-state Port	V _{DD} = 5.5 V, V _{OUT} = 5.5 V / 0 V	-	-	± 2	
"H" Output Voltage	V _{OH2}	Tri-state Port	V _{DD} = 4.5 V, I _{OH} = -0.7 mA	4.1	-	-	V
	V _{OH3}	P0	V _{DD} = 4.5 V, I _{OH} = -0.7 mA	4.1	-	-	
"L" Output Voltage	V _{OL3}	P0	V _{DD} = 4.5 V, I _{OL} = 1.6 mA	-	-	0.4	V
"L" Output Current	I _{OL1}	Except P0 and XOUT	V _{DD} = 4.5 V, V _{OL} = 0.4 V	-	1.6	-	mA
	I _{OL3}	P0	V _{DD} = 4.5 V, V _{OL} = 1.0 V	-	20	-	
Supply Current under NORMAL1, 2 mode	I _{DD}		V _{DD} = 5.5 V V _{IN} = 5.3 V / 0.2 V f _c = 16 MHz f _s = 32.768 kHz	-	5.5	7	mA
Supply Current under IDLE1, 2 mode				-	2.8	3.5	
Supply Current under SLOW1 mode			V _{DD} = 3.0 V V _{IN} = 2.8 V / 0.2 V f _s = 32.768 kHz	-	14	25	μA
Supply Current under SLEEP1 mode				-	7	15	μA
Supply Current under SLEEP0 mode				-	6	15	μA
Supply Current under STOP mode			V _{DD} = 5.5 V V _{IN} = 5.3 V / 0.2 V	-	0.5	10	μA

Note 1: Typical values are shown under T_{opr} = 25°C, V_{DD} = 5 V, while conditions are not stated.

Note 2: Input current I_{IN1}, I_{IN3}: The current through pull-up or pull-down resistor is not included.

A.C. Characteristics

(1) (V_{SS} = 0 V, V_{DD} = 4.5 to 5.5 V, T_{opr} = -40 to 85°C)

① CLOCK

Parameter	Symbol	Conditions	Min	Typ.	Max	Unit
Machine Cycle Time	t _{cy}	NORMAL1, 2 mode	0.25	-	10	μs
		IDLE0, 1, 2 mode				
		SLOW1, 2 mode	117.6	-	133.3	
		SLEEP0, 1, 2 mode				
High Level Clock Pulse Width	t _{WCH}	External clock operation (XIN input)	50	-	-	ns
Low Level Clock Pulse Width	t _{WCL}	f _c = 16 MHz				
High Level Clock Pulse Width	t _{WSH}	External clock operation (XTIN input)	14.7	-	-	μs
Low Level Clock Pulse Width	t _{WSL}	f _s = 32.768 kHz				

② External Memory Interface (Multiplexed Bus) at $V_{DD} = 4.5$ to 5.5

No.	Symbol	Parameter	Variable		16 MHz		Unit
			Min	Max	Min	Max	
1	t_{AL}	A7 to 0 effective \rightarrow ALE	$0.5t - 15$		16		ns
2	t_{LA}	ALE fall \rightarrow A7 to 0 hold	$0.5t - 20$		11		ns
3	t_{LL}	ALE pulse width	$t - 40$		22		ns
4	t_{LC}	ALE fall \rightarrow \overline{RD} , \overline{WR} fall	$0.5t - 25$		6		ns
5	t_{CL}	\overline{RD} , \overline{WR} rise \rightarrow ALE rise	$0.5t - 20$		11		ns
6	t_{ACL}	A7 to 0 effective \rightarrow \overline{RD} , \overline{WR} fall	$t - 25$		37		ns
7	t_{ACH}	A15 to 8 effective \rightarrow \overline{RD} , \overline{WR} fall	$1.5t - 25$		68		ns
8	t_{CA}	\overline{RD} , \overline{WR} rise \rightarrow A15 to 8 hold	$0.5t - 20$		11		ns
9	t_{ADL}	A7 to 0 effective \rightarrow D7 to 0 input		$3t - 55$		132	ns
10	t_{ADH}	A15 to 8 effective \rightarrow D7 to 0 input		$3.5t - 65$		153	ns
11	t_{RD}	\overline{RD} fall \rightarrow D7 to 0 input		$2t - 60$		65	ns
12	t_{RR}	\overline{RD} pulse width	$2t - 40$		85		ns
13	t_{HR}	\overline{RD} rise \rightarrow D7 to 0 hold	0		0		ns
14	t_{RAE}	\overline{RD} rise \rightarrow A7 to 0 effective	$t - 15$		47		ns
15	t_{WW}	\overline{WR} pulse width	$2t - 40$		85		ns
16	t_{DW}	D7 to 0 effective \rightarrow \overline{WR} rise	$2t - 40$		85		ns
17	t_{WD}	\overline{WR} rise \rightarrow D7 to 0 hold	$0.5t - 15$		16		ns

Note: $t = t_{cy}/4$ ($t = 62.5$ ns at $f_{cck} = 16$ MHz)

A.C. Measurement Condition

Output Level: High 2.2 V / Low 8.0V, CL = 50 pF

Input Level: High 2.4 V / Low 0.4 V (D7 to D0)

High 0.8 VDD / Low 0.2 VDD (Except D7 to D0)

Read Cycle

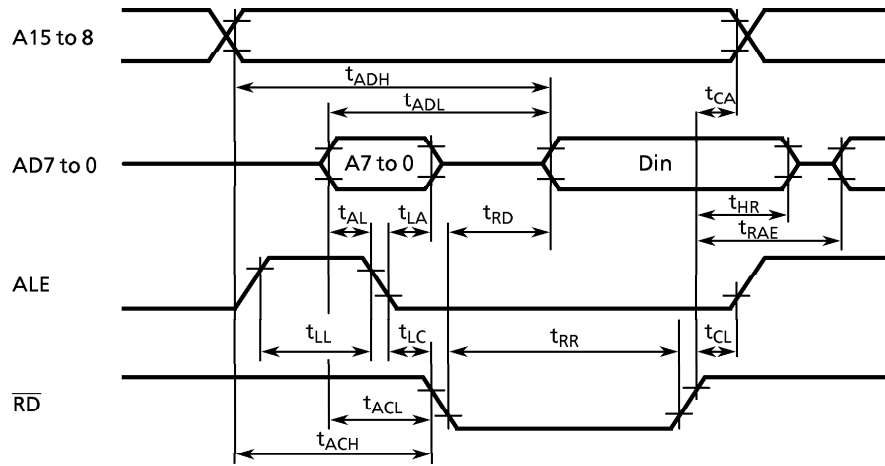

Write Cycle

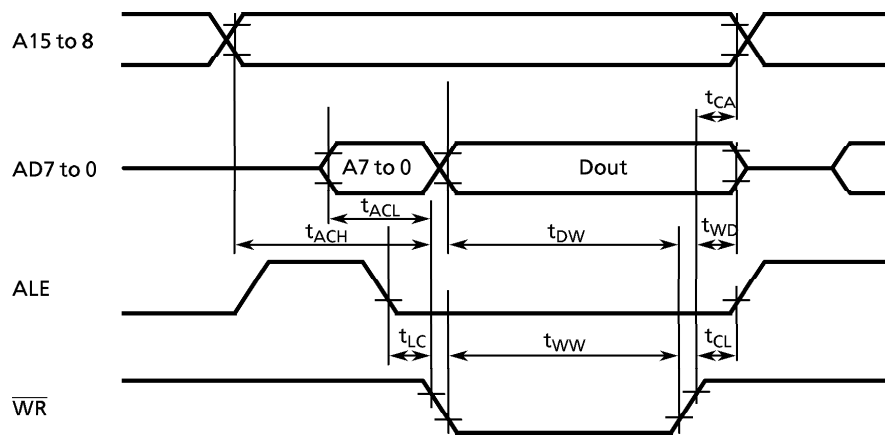

TC0, 1: External Input ($V_{cc} = 4.5$ to 5.5)

Unit: [ns]

Operating Mode	twh	twl
NORMAL	$8f_c + 25$	$8f_c + 25$
SLOW	$8f_s + 25$	$8f_s + 25$

TIn input

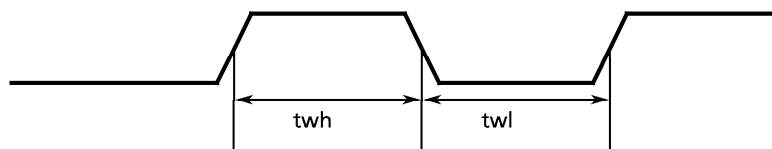

DC Characteristics, AC Characteristics (PROM mode) ($V_{SS} = 0\text{ V}$, $T_{opr} = -30\text{ to }70^\circ\text{C}$)

(1) Read operation in PROM mode

Parameter	Symbol	Conditions	Min	Typ.	Max	Unit
High level input voltage (TTL)	V_{IH4}		2.2	–	V_{CC}	V
Low level input voltage (TTL)	V_{IL4}		0	–	0.8	V
Power supply	V_{CC}		4.75	5.0	5.25	V
Power supply of program	V_{PP}					V
Address access time	t_{ACC}	$V_{CC} = 5.0 \pm 0.25\text{ V}$	–	$1.5\text{ }t_{cyc} + 300$	–	ns

Note: $t_{cyc} = 500\text{ ns}$ at 8 MHz

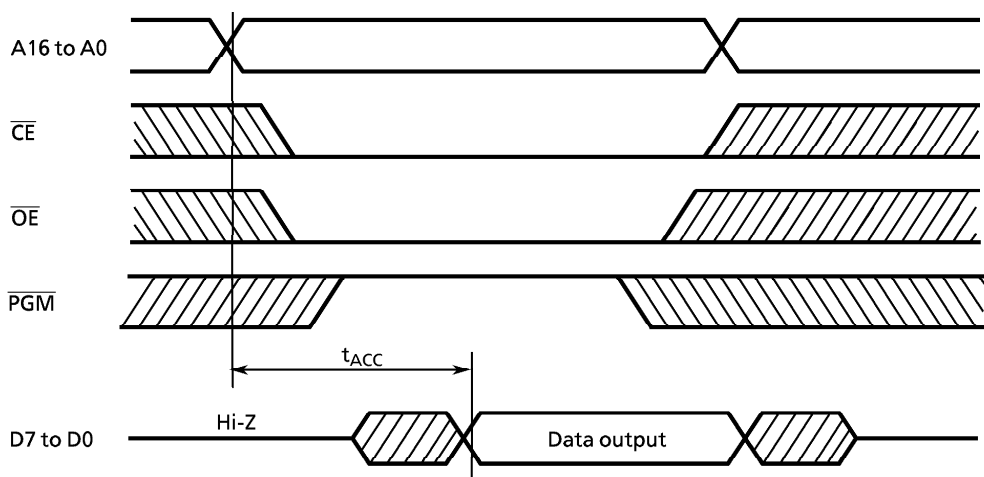

(2) Program operation (High-speed) ($T_{opr} = 25 \pm 5^\circ\text{C}$)

Parameter	Symbol	Conditions	Min	Typ.	Max	Unit
High level input voltage (TTL)	V_{IH4}		2.2	–	V_{CC}	V
Low level input voltage (TTL)	V_{IL4}		0	–	0.8	V
Power supply	V_{CC}		6.0	6.25	6.5	V
Power supply of program	V_{PP}		12.5	12.75	13.0	V
Pulse width of initializing program	t_{PW}	$V_{CC} = 6.0\text{ V}$	0.095	0.1	0.105	ms

High-speed program writing

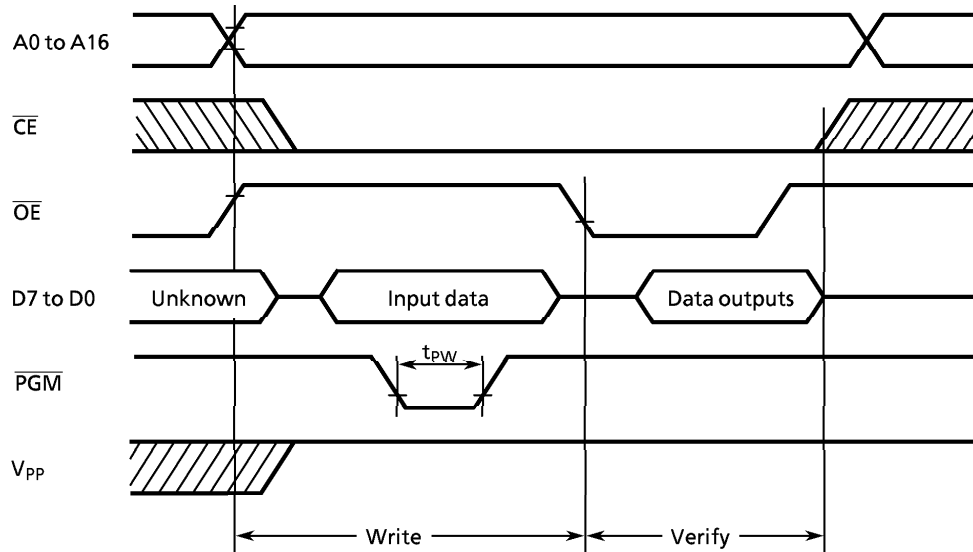

- Note 1:** The power supply of V_{pp} (12.75 V) must be set power-on at the same time or the later time for a power supply of V_{CC} and must be clear power-on at the same time or early time for a power supply of V_{CC} .
- Note 2:** The pulling up/down device on the condition of $V_{pp} = 12.75 V \pm 0.25 V$ causes a damage for the device. Do not pull up/down at programming.
- Note 3:** Use the recommended adapter (see 1.2.2 (1)) and mode (see 1.2.2 (3) i). Using other than the above condition may cause the trouble of the writing.

Looking for pricing, stock, or lifecycle information?

Click below to explore more details on WIN SOURCE:

- ⊖ [View TMP86PH06UG\(C,KJZ\) on WIN SOURCE](#)
- ⊖ [Toshiba Semiconductor and Storage Information](#)

Optimize Your Supply Chain with WIN SOURCE Solutions

- ✓ Global Sourcing Solution
- ✓ Obsolete Management
- ✓ Cost Control Management
- ✓ Shortage Management
- ✓ Alternative Solution
- ✓ Excess Inventory Management