



**THE DATASHEET OF
TLV5619QDWREP**



TLV5619-EP

2.7 V TO 5.5 V 12-BIT PARALLEL DIGITAL-TO-ANALOG CONVERTER WITH POWER DOWN

SGLS124A – JULY 2002 – REVISED DECEMBER 2003

- **Controlled Baseline**
 - One Assembly/Test Site, One Fabrication Site
- **Extended Temperature Performance of –40°C to 125°C**
- **Enhanced Diminishing Manufacturing Sources (DMS) Support**
- **Enhanced Product Change Notification**
- **Qualification Pedigree†**
- **Single Supply 2.7-V to 5.5-V Operation**
- **±0.4 LSB Differential Nonlinearity (DNL), ±1.5 LSB Integral Nonlinearity (INL)**
- **12-Bit Parallel Interface**
- **Compatible With TMS320 DSP**
- **Internal Power On Reset**
- **Settling Time 1 μs Typ**
- **Low Power Consumption:**
 - 8 mW for 5-V Supply
 - 4.3 mW for 3-V Supply
- **Reference Input Buffers**
- **Voltage Output**
- **Monotonic Over Temperature**
- **Asynchronous Update**

applications

- **Battery Powered Test Instruments**
- **Digital Offset and Gain Adjustment**
- **Battery Operated/Remote Industrial Controls**
- **Machine and Motion Control Devices**
- **Cordless and Wireless Telephones**
- **Speech Synthesis**
- **Communication Modulators**
- **Arbitrary Waveform Generation**

† Component qualification in accordance with JEDEC and industry standards to ensure reliable operation over an extended temperature range. This includes, but is not limited to, Highly Accelerated Stress Test (HAST) or biased 85/85, temperature cycle, autoclave or unbiased HAST, electromigration, bond intermetallic life, and mold compound life. Such qualification testing should not be viewed as justifying use of this component beyond specified performance and environmental limits.

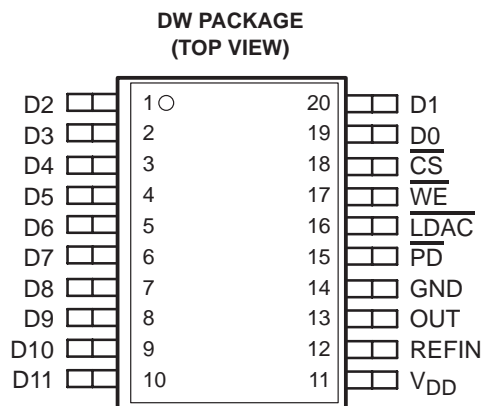

description

The TLV5619 is a 12-bit voltage output DAC with a microprocessor and TMS320 compatible parallel interface. The 12 data bits are double buffered so that the output can be updated asynchronously using the $\overline{\text{LDAC}}$ pin. During normal operation, the device dissipates 8 mW at a 5-V supply and 4.3 mW at a 3-V supply. The power consumption can be lowered to 50 nW by setting the DAC to power-down mode.

The output voltage is buffered by a $\times 2$ gain rail-to-rail amplifier, which features a Class A output stage to improve stability and reduce settling time.

ORDERING INFORMATION

T _A	PACKAGE‡		ORDERABLE PART NUMBER	TOP-SIDE MARKING
–40°C to 125°C	SOP – DW	Tape and reel	TLV5619QDWREP	TLV5619QEP

‡ Package drawings, standard packing quantities, thermal data, symbolization, and PCB design guidelines are available at www.ti.com/sc/package.



Please be aware that an important notice concerning availability, standard warranty, and use in critical applications of Texas Instruments semiconductor products and disclaimers thereto appears at the end of this data sheet.

PRODUCTION DATA information is current as of publication date. Products conform to specifications per the terms of Texas Instruments standard warranty. Production processing does not necessarily include testing of all parameters.



POST OFFICE BOX 655303 • DALLAS, TEXAS 75265

Copyright © 2002 – 2003, Texas Instruments Incorporated

TLV5619-EP

2.7 V TO 5.5 V 12-BIT PARALLEL DIGITAL-TO-ANALOG CONVERTER WITH POWER DOWN

SGLS124A – JULY 2002 – REVISED DECEMBER 2003

absolute maximum ratings over operating free-air temperature range (unless otherwise noted)†

Supply voltage (V_{DD} to GND)	7 V
Analog input voltage range	– 0.3 V to $V_{DD} + 0.3$ V
Reference input voltage	$V_{DD} + 0.3$ V
Digital input voltage range to GND	– 0.3 V to $V_{DD} + 0.3$ V
Operating free-air temperature range, T_A :	–40°C to 125°C
Storage temperature range, T_{stg}	–65°C to 150°C
Lead temperature 1,6 mm (1/16 inch) from case for 10 seconds	260°C

† Stresses beyond those listed under “absolute maximum ratings” may cause permanent damage to the device. These are stress ratings only, and functional operation of the device at these or any other conditions beyond those indicated under “recommended operating conditions” is not implied. Exposure to absolute-maximum-rated conditions for extended periods may affect device reliability.

recommended operating conditions

	MIN	NOM	MAX	UNIT
Supply voltage, V_{DD} (5-V Supply)	4.5	5	5.5	V
Supply voltage, V_{DD} (3-V Supply)	2.7	3	3.3	V
High-level digital input voltage, V_{IH}	$V_{DD} = 2.7$ V			V
	$V_{DD} = 5.5$ V			
Low-level digital input voltage, V_{IL}	$V_{DD} = 2.7$ V			V
	$V_{DD} = 5.5$ V			
Reference voltage, V_{ref} to REFIN terminal (5-V Supply)	0	2.048	$V_{DD} - 1.5$	V
Reference voltage, V_{ref} to REFIN terminal (3-V Supply)	0	1.024	$V_{DD} - 1.5$	V
Load resistance, R_L	2	10		k Ω
Load capacitance, C_L			100	pF
Operating free-air temperature, T_A	–40		125	°C

- NOTES: 1. The recommended operating levels for both V_{IH} and V_{IL} apply to all valid values of V_{DD} .
 2. Reference input voltages greater than $V_{DD}/2$ will cause output saturation for large DAC codes.



TLV5619-EP

2.7 V TO 5.5 V 12-BIT PARALLEL DIGITAL-TO-ANALOG CONVERTER WITH POWER DOWN

SGLS124A – JULY 2002 – REVISED DECEMBER 2003

electrical characteristics over recommended operating free-air temperature range, supply voltages, and reference voltages (unless otherwise noted)

static DAC specifications

PARAMETER		TEST CONDITIONS	MIN	TYP	MAX	UNIT
Resolution		$V_{ref}(REFIN) = 2.048\text{ V at } 5\text{ V,}$ $1.024\text{ V at } 3\text{ V}$	12			bits
Integral nonlinearity (INL)		$V_{ref}(REFIN) = 2.048\text{ V at } 5\text{ V,}$ $1.024\text{ V at } 3\text{ V,}$ See Note 3		±1.5	±4	LSB
Differential nonlinearity (DNL)		$V_{ref}(REFIN) = 2.048\text{ V at } 5\text{ V,}$ $1.024\text{ V at } 3\text{ V,}$ See Note 4		±0.4	±1	LSB
EZS	Zero-scale error (offset error at zero scale)	$V_{ref}(REFIN) = 2.048\text{ V at } 5\text{ V,}$ $1.024\text{ V at } 3\text{ V,}$ See Note 5		±3	±20	mV
Zero-scale-error temperature coefficient		$V_{ref}(REFIN) = 2.048\text{ V at } 5\text{ V,}$ $1.024\text{ V at } 3\text{ V,}$ See Note 6		3		ppm/°C
EG	Gain error	$V_{ref}(REFIN) = 2.048\text{ V at } 5\text{ V,}$ $1.024\text{ V at } 3\text{ V,}$ See Note 7		±0.25	±0.5	% of FS voltage
Gain error temperature coefficient		$V_{ref}(REFIN) = 2.048\text{ V at } 5\text{ V,}$ $1.024\text{ V at } 3\text{ V,}$ See Note 8		1		ppm/°C
PSRR	Power-supply rejection ratio	See Notes 9 and 10		65		dB
	Zero scale			65		
	Gain			65		

- NOTES:
- The relative accuracy or integral nonlinearity (INL), sometimes referred to as linearity error, is the maximum deviation of the output from the line between zero and full scale excluding the effects of zero code and full-scale errors.
 - The differential nonlinearity (DNL), sometimes referred to as differential error, is the difference between the measured and ideal 1 LSB amplitude change of any two adjacent codes. Monotonic means the output voltage changes in the same direction (or remains constant) as a change in the digital input code.
 - Zero-scale error is the deviation from zero voltage output when the digital input code is zero.
 - Zero-scale-error temperature coefficient is given by: $E_{ZS} TC = [E_{ZS}(T_{max}) - E_{ZS}(T_{min})]/V_{ref} \times 10^6/(T_{max} - T_{min})$.
 - Gain error is the deviation from the ideal output ($2 \times V_{ref} - 1$ LSB) with an output load of 10 kΩ excluding the effects of the zero-error.
 - Gain temperature coefficient is given by: $E_G TC = [E_G(T_{max}) - E_G(T_{min})]/V_{ref} \times 10^6/(T_{max} - T_{min})$.
 - Zero-scale-error rejection ratio (EZS-RR) is measured by varying the V_{DD} from 4.5 V to 5.5 V dc and measuring the proportion of this signal imposed on the zero-code output voltage.
 - Gain-error rejection ratio (EG-RR) is measured by varying the V_{DD} from 4.5 V to 5.5 V dc and measuring the proportion of this signal imposed on the full-scale output voltage after subtracting the zero scale change.

output specifications

PARAMETER		TEST CONDITIONS	MIN	TYP	MAX	UNIT
V_O	Voltage output range	$R_L = 10\text{ k}\Omega$	0		$V_{DD}-0.4$	V
Output load regulation accuracy		$V_O(OUT) = 4.096\text{ V,}$ 2.048 V $R_L = 2\text{ k}\Omega$		0.1	0.29	% of FS voltage
$I_{OSC(source)}$	Output short circuit source current	$V_O(OUT) = 0\text{ V,}$ Full scale code	5-V Supply	100		mA
			3-V Supply	25		
$I_O(source)$	Output source current	$R_L = 100\ \Omega$	5-V Supply	10		mA
			3-V Supply	10		



TLV5619-EP
2.7 V TO 5.5 V 12-BIT PARALLEL DIGITAL-TO-ANALOG CONVERTER
WITH POWER DOWN

SGLS124A – JULY 2002 – REVISED DECEMBER 2003

electrical characteristics over recommended operating free-air temperature range, supply voltages, and reference voltages (unless otherwise noted)

reference input (REFIN)

PARAMETER	TEST CONDITIONS	MIN	TYP	MAX	UNIT
V _{ref} Reference input voltage	See Note 11	0		V _{DD} -1.5	V
R _i Reference input resistance			10		MΩ
C _i Reference input capacitance			5		pF
Reference feed through	REFIN = 1 V _{pp} at 1 kHz + 1.024 V dc (see Note 12)		-60		dB
Reference input bandwidth	REFIN = 0.2 V _{pp} + 1.024 V dc at -3 dB		1.4		MHz

NOTES: 11. Reference input voltages greater than V_{DD}/2 will cause output saturation for large DAC codes.

12. Reference feedthrough is measured at the DAC output with an input code = 0x000 and a V_{ref}(REFIN) input = 1.024 V dc + 1 V_{pp} at 1 kHz.

digital inputs (D0 – D11, \overline{CS} , \overline{WE} , \overline{LDAC} , \overline{PD})

PARAMETER	TEST CONDITIONS	MIN	TYP	MAX	UNIT
I _{IH} High-level digital input current	V _I = V _{DD}			1	μA
I _{IL} Low-level digital input current	V _I = 0 V			-1	μA
C _i Input capacitance			8		pF

power supply

PARAMETER	TEST CONDITIONS	MIN	TYP	MAX	UNIT	
I _{DD} Power supply current	No load, All inputs 0 V or V _{DD}		5-V Supply	1.6	3	mA
			3-V Supply	1.44	2.7	
Power down supply current			0.01	10	μA	



TLV5619-EP

2.7 V TO 5.5 V 12-BIT PARALLEL DIGITAL-TO-ANALOG CONVERTER WITH POWER DOWN

SGLS124A – JULY 2002 – REVISED DECEMBER 2003

operating characteristics over recommended operating free-air temperature range, supply voltages, and reference voltages (unless otherwise noted)

analog output dynamic performance

PARAMETER		TEST CONDITIONS		MIN	TYP	MAX	UNIT
SR	Slew rate	C _L = 100 pF, R _L = 10 kΩ, Code 32 to code 4095, Code 4095 to code 32,	V _{ref} (REFIN) = 2.048 V, 1.024 V, V _O from 10% to 90% 90% to 10%	5-V Supply	8	12	V/μs
				3-V Supply	6	9	V/μs
t _s	Output settling time (full scale)	To ±0.5 LSB, R _L = 10 kΩ,	C _L = 100 pF, See Note 13		1	3	μs
	Glitch energy	DIN = all 0s to all 1s			5		nV-s
S/N	Signal to noise	f _s = 480 kSPS, BW = 20 kHz, C _L = 100 pF,	f _{OUT} = 1 kHz, R _L = 10 kΩ, T _A = 25°C, See Note 14	5-V Supply	65	78	dB
S/(N+D)	Signal to noise + distortion	f _s = 480 kSPS, BW = 20 kHz, C _L = 100 pF,	f _{OUT} = 1 kHz, R _L = 10 kΩ, T _A = 25°C, See Note 14	5-V Supply	58	67	
				3-V Supply	58	69	
	Total harmonic distortion	f _s = 480 kSPS, BW = 20 kHz, C _L = 100 pF,	f _{OUT} = 1 kHz, R _L = 10 kΩ, T _A = 25°C, See Note 14		-68	-60	
	Spurious free dynamic range	f _s = 480 kSPS, BW = 20 kHz, C _L = 100 pF,	f _{OUT} = 1 kHz, R _L = 10 kΩ, T _A = 25°C, See Note 14		60	72	

NOTES: 13. Settling time is the time for the output signal to remain within ±0.5 LSB of the final measured value for a digital input code change of 0x020 to 0x3DF or 0x3DF to 0x020. Limits are ensured by design and characterization, but are not production tested.

14. 1 kHz sinewave generated by DAC, reference voltage = 1.024 V at 3 V and 2.048 V at 5 V.

timing requirement

digital inputs

		MIN	NOM	MAX	UNIT
t _{su} (CS-WE)	Setup time, $\overline{\text{CS}}$ low before positive $\overline{\text{WE}}$ edge	13			ns
t _{su} (D)	Setup time, data ready before positive $\overline{\text{WE}}$ edge	9			ns
t _h (D)	Hold time, data held after positive $\overline{\text{WE}}$ edge	0			ns
t _{su} (WE-LD)	Setup time, positive $\overline{\text{WE}}$ edge before $\overline{\text{LDAC}}$ low	0			ns
t _{wh} (WE)	Pulse width, $\overline{\text{WE}}$ high	25			ns
t _w (LD)	Pulse width, $\overline{\text{LDAC}}$ low	25			ns



TLV5619-EP
2.7 V TO 5.5 V 12-BIT PARALLEL DIGITAL-TO-ANALOG CONVERTER
WITH POWER DOWN

SGLS124A – JULY 2002 – REVISED DECEMBER 2003

PARAMETER MEASUREMENT INFORMATION

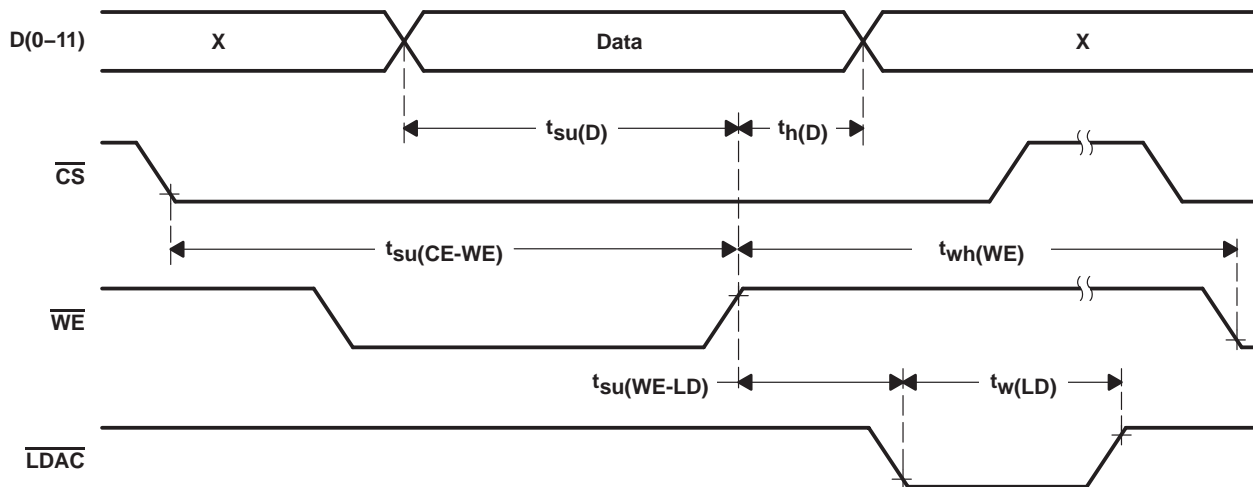

Figure 1. Timing Diagram

TLV5619-EP
2.7 V TO 5.5 V 12-BIT PARALLEL DIGITAL-TO-ANALOG CONVERTER
WITH POWER DOWN

SGLS124A – JULY 2002 – REVISED DECEMBER 2003

TYPICAL CHARACTERISTICS

**MAXIMUM OUTPUT VOLTAGE
vs
LOAD**

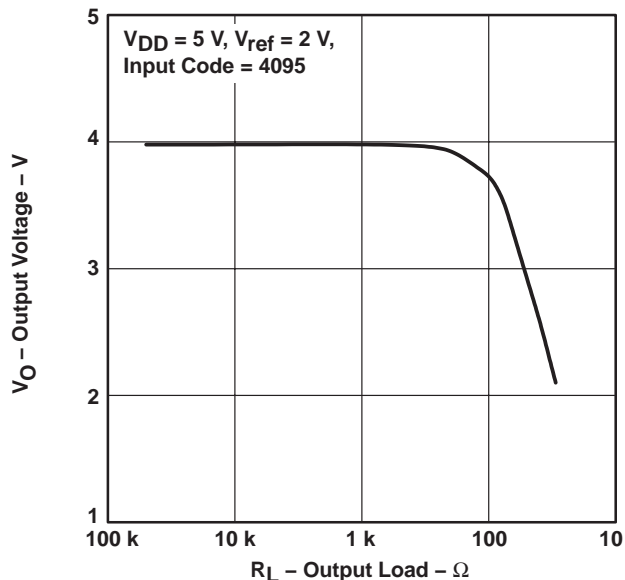

Figure 2

**MAXIMUM OUTPUT VOLTAGE
vs
LOAD**

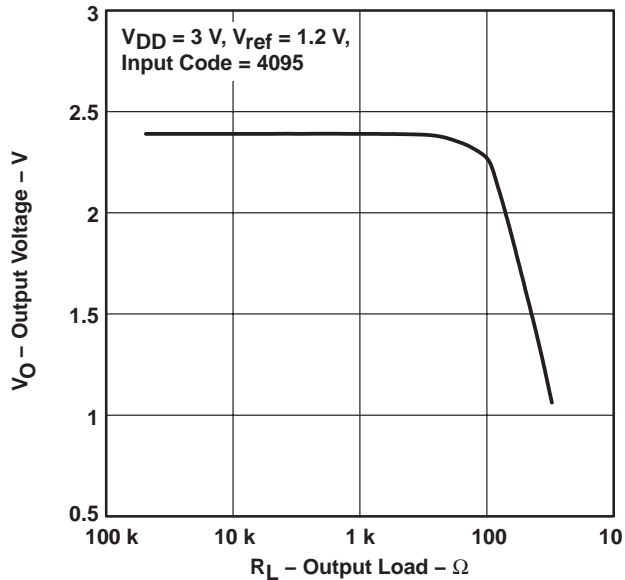

Figure 3

**TOTAL HARMONIC DISTORTION
vs
LOAD**

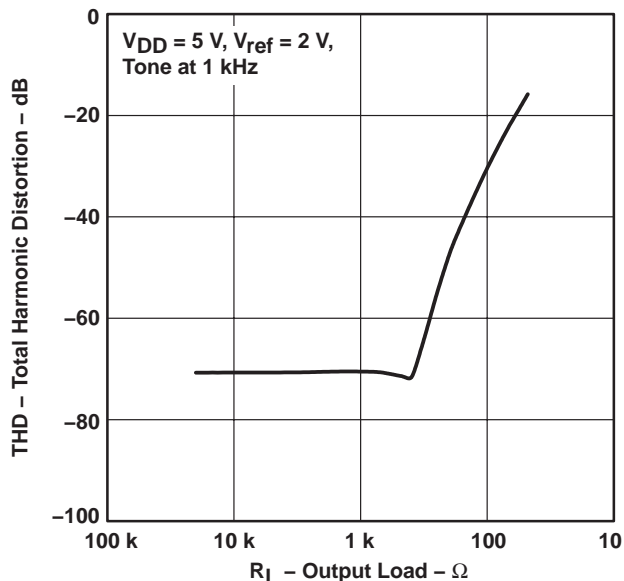

Figure 4

**TOTAL HARMONIC DISTORTION
vs
FREQUENCY**

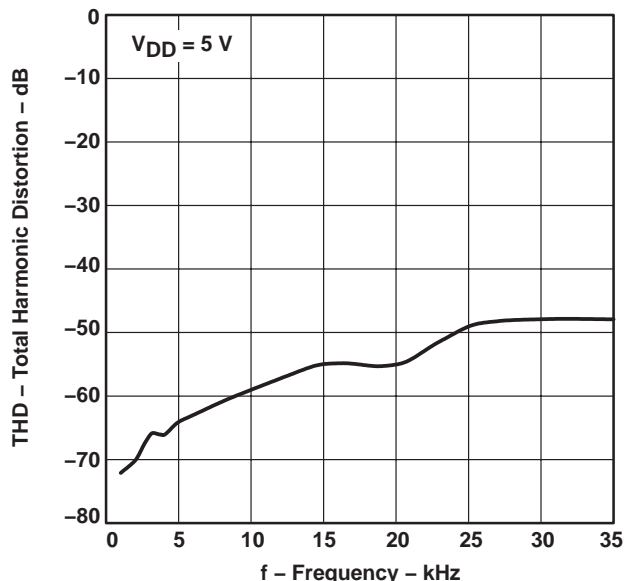

Figure 5



TLV5619-EP
2.7 V TO 5.5 V 12-BIT PARALLEL DIGITAL-TO-ANALOG CONVERTER
WITH POWER DOWN

SGLS124A – JULY 2002 – REVISED DECEMBER 2003

TYPICAL CHARACTERISTICS

SIGNAL-TO-NOISE + DISTORTION
VS
FREQUENCY

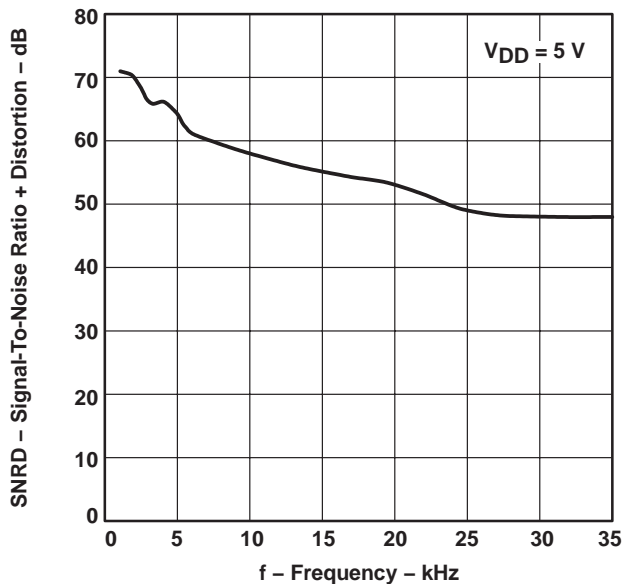

Figure 6

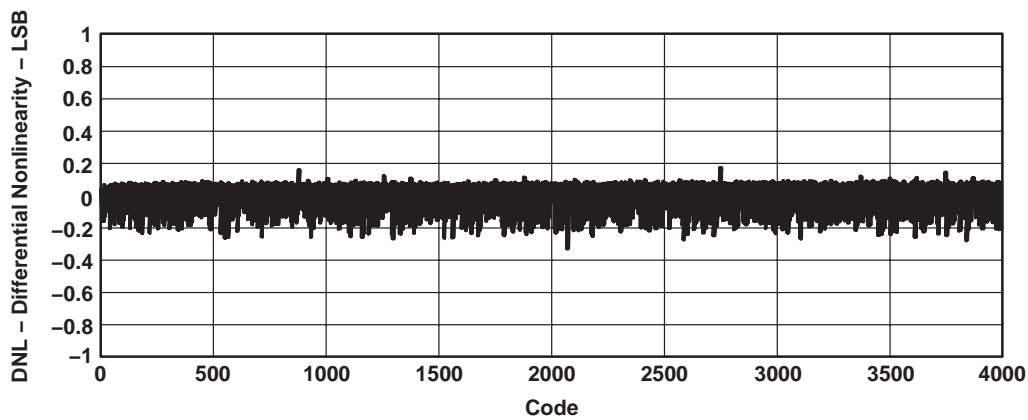

Figure 7. Differential Nonlinearity

TLV5619-EP
2.7 V TO 5.5 V 12-BIT PARALLEL DIGITAL-TO-ANALOG CONVERTER
WITH POWER DOWN

SGLS124A – JULY 2002 – REVISED DECEMBER 2003

TYPICAL CHARACTERISTICS

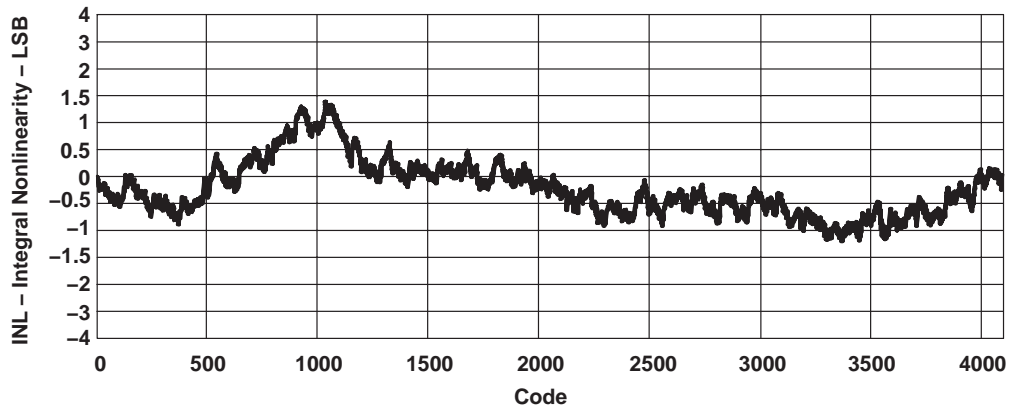

Figure 8. Integral Nonlinearity

POWER DOWN SUPPLY CURRENT
VS
TIME

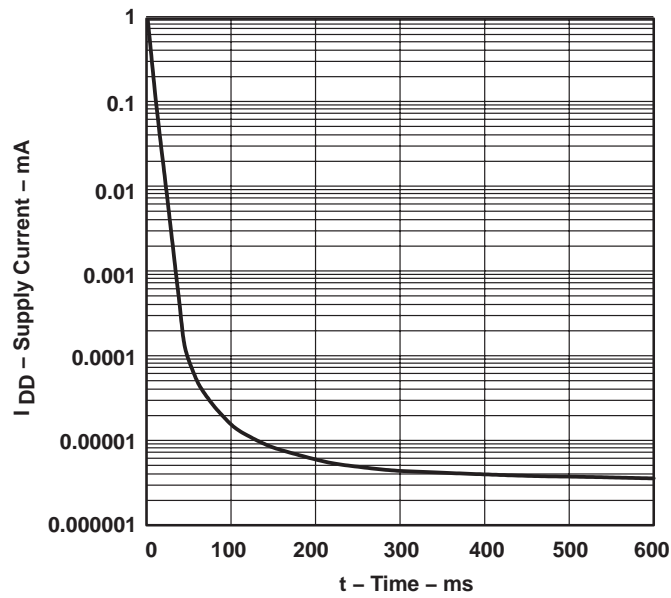

Figure 9

APPLICATION INFORMATION

definitions of specifications and terminology

integral nonlinearity (INL)

The relative accuracy or integral nonlinearity (INL), sometimes referred to as linearity error, is the maximum deviation of the output from the line between zero and full scale excluding the effects of zero code and full-scale errors.

differential nonlinearity (DNL)

The differential nonlinearity (DNL), sometimes referred to as differential error, is the difference between the measured and ideal 1 LSB amplitude change of any two adjacent codes. Monotonic means the output voltage changes in the same direction (or remains constant) as a change in the digital input code.

zero-scale error (E_{ZS})

Zero-scale error is defined as the deviation of the output from 0 V at a digital input value of 0.

gain error (E_G)

Gain error is the error in slope of the DAC transfer function.

signal-to-noise ratio + distortion (S/N+D)

S/N+D is the ratio of the rms value of the output signal to the rms sum of all other spectral components below the Nyquist frequency, including harmonics but excluding dc. The value for S/N+D is expressed in decibels.

spurious free dynamic range (SFDR)

SFDR is the difference between the rms value of the output signal and the rms value of the largest spurious signal within a specified bandwidth. The value for SFDR is expressed in decibels.

total harmonic distortion (THD)

THD is the ratio of the rms sum of the first six harmonic components to the rms value of the fundamental signal and is expressed in decibels.

TLV5619-EP

2.7 V TO 5.5 V 12-BIT PARALLEL DIGITAL-TO-ANALOG CONVERTER WITH POWER DOWN

SGLS124A – JULY 2002 – REVISED DECEMBER 2003

APPLICATION INFORMATION

linearity, offset, and gain error using single end supplies

When an amplifier is operated from a single supply, the voltage offset can still be either positive or negative. With a positive offset, the output voltage changes on the first code change. With a negative offset the output voltage may not change with the first code depending on the magnitude of the offset voltage.

The output amplifier attempts to drive the output to a negative voltage. However, because the most negative supply rail is ground, the output cannot drive below ground and clamps the output at 0 V.

The output voltage remains at zero until the input code value produces a sufficient positive output voltage to overcome the negative offset voltage, resulting in the transfer function shown in Figure 10.

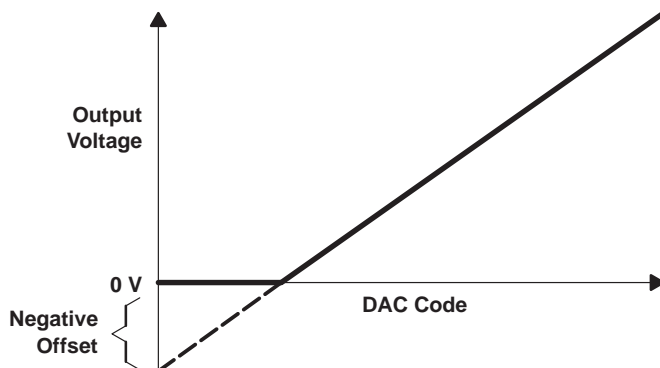

Figure 10. Effect of Negative Offset (Single Supply)

This offset error, not the linearity error, produces this breakpoint. The transfer function would have followed the dotted line if the output buffer could drive below the ground rail.

For a DAC, linearity is measured between zero input code (all inputs 0) and full scale code (all inputs 1) after offset and full scale are adjusted out or accounted for in some way. However, single supply operation does not allow for adjustment when the offset is negative due to the breakpoint in the transfer function. So the linearity is measured between full scale code and the lowest code that produces a positive output voltage.

general function

The TLV5619 is a 12-bit, single supply DAC, based on a resistor string architecture. It consists of a parallel interface, a power down control logic, a resistor string, and a rail-to-rail output buffer. The output voltage (full scale determined by reference) is given by:

$$2 \text{ REF} \frac{\text{CODE}}{0x1000} \text{ [V]}$$

Where REF is the reference voltage and CODE is the digital input value, range 0x000 to 0xFFF. A power on reset initially puts the internal latches to a defined state (all bits zero).

APPLICATION INFORMATION

parallel interface

The device latches data on the positive edge of \overline{WE} . It must be enabled with \overline{CS} low. \overline{LDAC} low updates the DAC with the value in the holding latch. \overline{LDAC} is an asynchronous input and can be held low, if a separate update is not necessary. However, to control the DAC using the load feature, \overline{LDAC} can be driven low after the positive \overline{WE} edge.

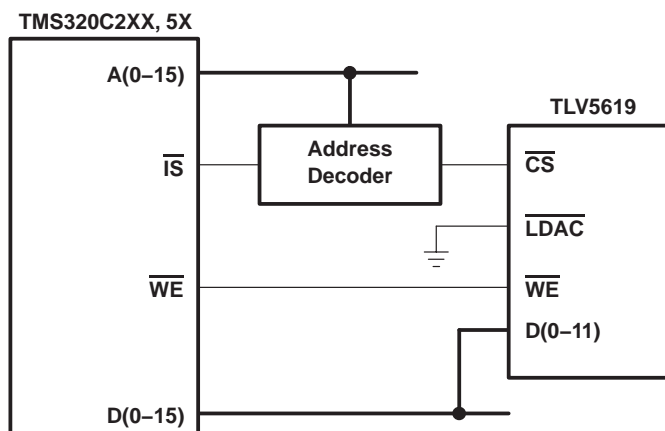

Figure 11. Proposed Interface Between TLV5619 and TMS320C2XX, 5X DSPs

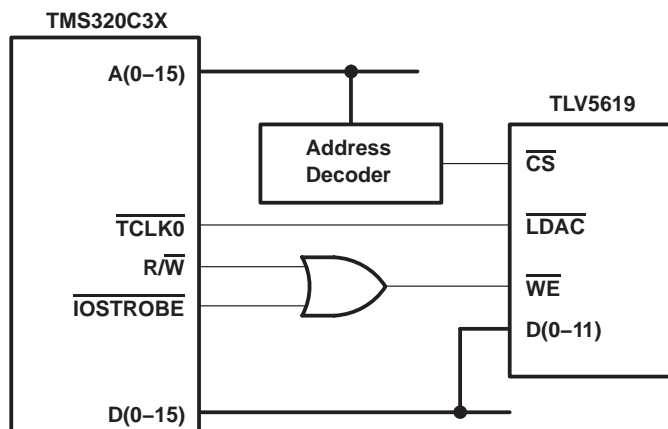

Figure 12. Proposed Interface Between TLV5619 and TMS320C3X DSPs

TLV5619-EP

2.7 V TO 5.5 V 12-BIT PARALLEL DIGITAL-TO-ANALOG CONVERTER WITH POWER DOWN

SGLS124A – JULY 2002 – REVISED DECEMBER 2003

APPLICATION INFORMATION

TLV5619 interfaced to TMS320C203 DSP

hardware interface

Figure 13 shows an example of the connection between the TLV5619 and the TMS320C203 DSP. The only other device that is needed in addition to the DSP and the DAC is the 74AC138 address decoding circuit. Using this configuration, the DAC address is 0x0084 within the I/O memory space of the TMS320C203.

$\overline{\text{LDAC}}$ is held low so that the output voltage is updated with the rising $\overline{\text{WE}}$ edge. The power down mode is deactivated permanently by pulling $\overline{\text{PD}}$ to V_{DD} .

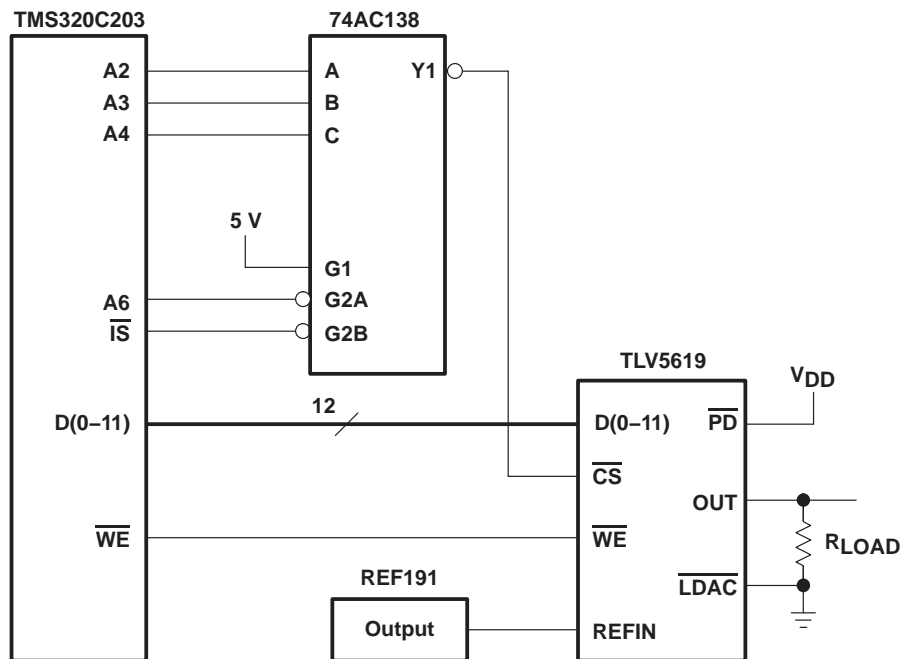

Figure 13. TLV5619 to TMS320C203 DSP Interface Connection

software

No setup procedure is needed to access the TLV5619. The output voltage can be set using one command:

```
out data_addr, DAC_addr
```

Where `data_addr` points to the address location (in this example 0x0060) holding the new output voltage data and `DAC_addr` is the I/O space address of the TLV5619 (in this example 0x0084).

The following code shows, how to use the timer of the TMS320C203 as a time base to generate a voltage ramp with the TLV5619. A timer interrupt is generated every 205 μs . The corresponding interrupt service routine increments the output code (stored at 0x0060) for the DAC and writes the new code to the TLV5619. Only the 12 LSBs of the data in 0x0060 are used by the DAC, so that the resulting period of the saw waveform is:

$$\tau = 4096 \times 205 \text{ E-6 s} = 0.84 \text{ s}$$

APPLICATION INFORMATION

software listing

```

; File: ramp.asm
; Description: This program generates a ramp.

;----- I/O and memory mapped regs -----
        .include "regs.asm"
TLV5619 .equ  0084h
;----- vectors -----
        .ps    0h
        b     start
        b     INT1
        b     INT23
        b     TIM_ISR

*****
* Main Program
*****

        .ps    1000h
        .entry

start:
        ldp   #0      ; set data page to 0
; disable interrupts
        setc  INTM    ; disable maskable interrupts
        splk #0ffffh, IFR
        splk #0004h,  IMR

; set up the timer
        splk #0000h,  60h
        splk #0042h,  61h
        out  61h, PRD
        out  60h, TIM
        splk #0c2fh,  62h
        out  62h,   TCR

; enable interrupts
        clrc  INTM    ; enable maskable interrupts

; loop forever!
next    idle          ; wait for interrupt

        b     next
; all else fails stop here
done    b           done ; hang there

*****
* Interrupt Service Routines
*****

INT1:   ret           ; do nothing and return
INT23:  ret           ; do nothing and return

TIM_ISR:
; useful code
        add   #1h    ; increment accumulator
        sacl 60h
        out  60h, TLV5619 ; write to DAC
        clrc intm ; re-enable interrupts
        ret           ; return from interrupt
        .end

```

PACKAGING INFORMATION

Orderable Device	Status ⁽¹⁾	Package Type	Package Drawing	Pins	Package Qty	Eco Plan ⁽²⁾	Lead/Ball Finish	MSL Peak Temp ⁽³⁾
TLV5619QDWREP	ACTIVE	SOIC	DW	20	2000	Green (RoHS & no Sb/Br)	CU NIPDAU	Level-1-260C-UNLIM
V62/03615-01XE	ACTIVE	SOIC	DW	20	2000	Green (RoHS & no Sb/Br)	CU NIPDAU	Level-1-260C-UNLIM

⁽¹⁾ The marketing status values are defined as follows:

ACTIVE: Product device recommended for new designs.

LIFEBUY: TI has announced that the device will be discontinued, and a lifetime-buy period is in effect.

NRND: Not recommended for new designs. Device is in production to support existing customers, but TI does not recommend using this part in a new design.

PREVIEW: Device has been announced but is not in production. Samples may or may not be available.

OBsolete: TI has discontinued the production of the device.

⁽²⁾ Eco Plan - The planned eco-friendly classification: Pb-Free (RoHS), Pb-Free (RoHS Exempt), or Green (RoHS & no Sb/Br) - please check <http://www.ti.com/productcontent> for the latest availability information and additional product content details.

TBD: The Pb-Free/Green conversion plan has not been defined.

Pb-Free (RoHS): TI's terms "Lead-Free" or "Pb-Free" mean semiconductor products that are compatible with the current RoHS requirements for all 6 substances, including the requirement that lead not exceed 0.1% by weight in homogeneous materials. Where designed to be soldered at high temperatures, TI Pb-Free products are suitable for use in specified lead-free processes.

Pb-Free (RoHS Exempt): This component has a RoHS exemption for either 1) lead-based flip-chip solder bumps used between the die and package, or 2) lead-based die adhesive used between the die and leadframe. The component is otherwise considered Pb-Free (RoHS compatible) as defined above.

Green (RoHS & no Sb/Br): TI defines "Green" to mean Pb-Free (RoHS compatible), and free of Bromine (Br) and Antimony (Sb) based flame retardants (Br or Sb do not exceed 0.1% by weight in homogeneous material)

⁽³⁾ MSL, Peak Temp. -- The Moisture Sensitivity Level rating according to the JEDEC industry standard classifications, and peak solder temperature.

Important Information and Disclaimer:The information provided on this page represents TI's knowledge and belief as of the date that it is provided. TI bases its knowledge and belief on information provided by third parties, and makes no representation or warranty as to the accuracy of such information. Efforts are underway to better integrate information from third parties. TI has taken and continues to take reasonable steps to provide representative and accurate information but may not have conducted destructive testing or chemical analysis on incoming materials and chemicals. TI and TI suppliers consider certain information to be proprietary, and thus CAS numbers and other limited information may not be available for release.

In no event shall TI's liability arising out of such information exceed the total purchase price of the TI part(s) at issue in this document sold by TI to Customer on an annual basis.

OTHER QUALIFIED VERSIONS OF TLV5619-EP :

- Catalog: [TLV5619](#)

NOTE: Qualified Version Definitions:

- Catalog - TI's standard catalog product

TAPE AND REEL INFORMATION

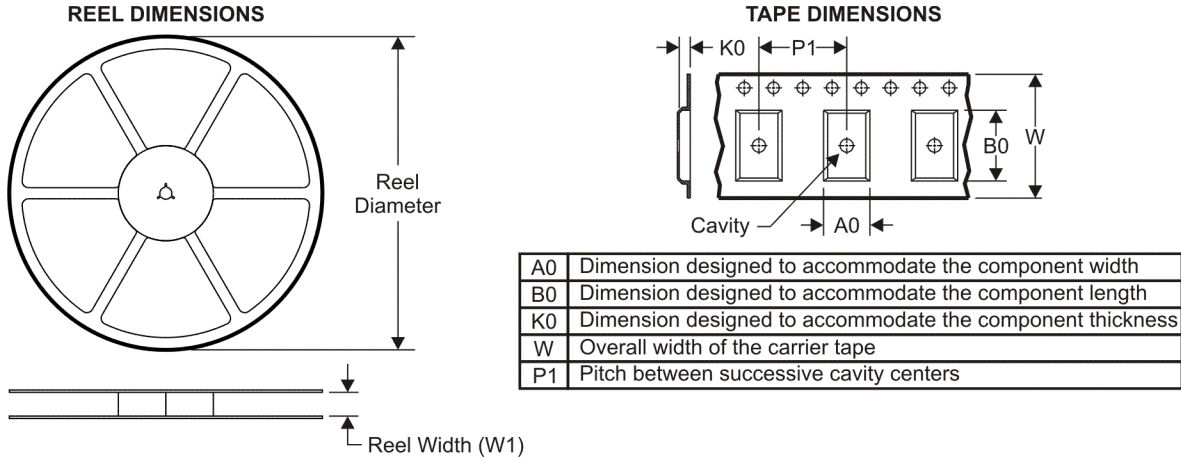

QUADRANT ASSIGNMENTS FOR PIN 1 ORIENTATION IN TAPE

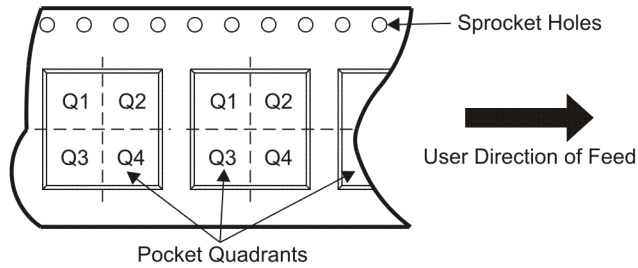

*All dimensions are nominal

Device	Package Type	Package Drawing	Pins	SPQ	Reel Diameter (mm)	Reel Width W1 (mm)	A0 (mm)	B0 (mm)	K0 (mm)	P1 (mm)	W (mm)	Pin1 Quadrant
TLV5619QDWREP	SOIC	DW	20	2000	330.0	24.4	10.8	13.1	2.65	12.0	24.0	Q1

TAPE AND REEL BOX DIMENSIONS

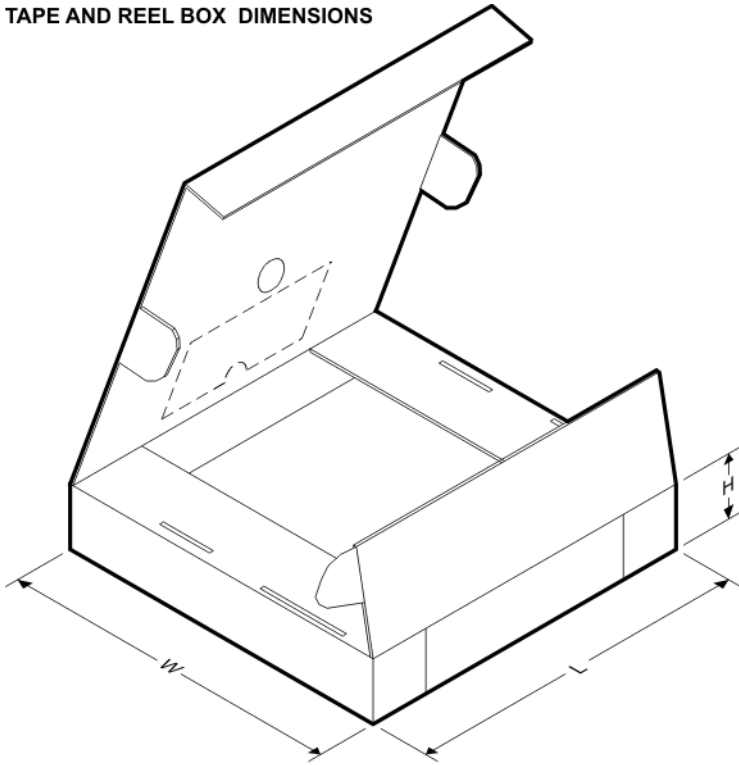

*All dimensions are nominal

Device	Package Type	Package Drawing	Pins	SPQ	Length (mm)	Width (mm)	Height (mm)
TLV5619QDWREP	SOIC	DW	20	2000	346.0	346.0	41.0

DW (R-PDSO-G20)

PLASTIC SMALL-OUTLINE PACKAGE

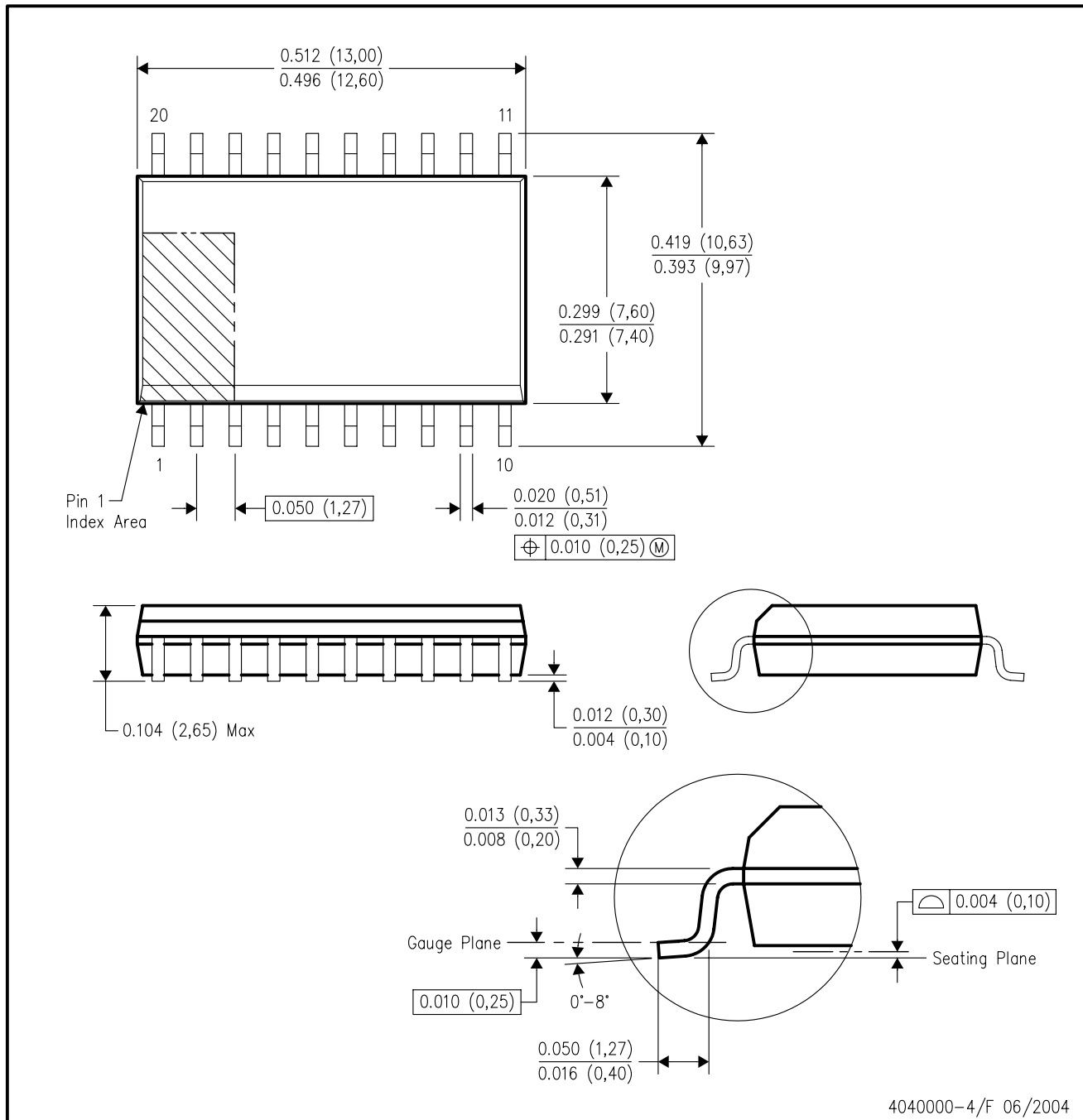

- NOTES:
- A. All linear dimensions are in inches (millimeters).
 - B. This drawing is subject to change without notice.
 - C. Body dimensions do not include mold flash or protrusion not to exceed 0.006 (0,15).
 - D. Falls within JEDEC MS-013 variation AC.

PACKAGING INFORMATION

Orderable Device	Status (1)	Package Type	Package Drawing	Pins	Package Qty	Eco Plan (2)	Lead finish/ Ball material (6)	MSL Peak Temp (3)	Op Temp (°C)	Device Marking (4/5)	Samples
TLV5619QDWREP	ACTIVE	SOIC	DW	20	2000	RoHS & Green	NIPDAU	Level-1-260C-UNLIM	-40 to 125	TLV5619QEP	Samples
V62/03615-01XE	ACTIVE	SOIC	DW	20	2000	RoHS & Green	NIPDAU	Level-1-260C-UNLIM	-40 to 125	TLV5619QEP	Samples

(1) The marketing status values are defined as follows:

ACTIVE: Product device recommended for new designs.

LIFEBUY: TI has announced that the device will be discontinued, and a lifetime-buy period is in effect.

NRND: Not recommended for new designs. Device is in production to support existing customers, but TI does not recommend using this part in a new design.

PREVIEW: Device has been announced but is not in production. Samples may or may not be available.

OBSOLETE: TI has discontinued the production of the device.

(2) **RoHS:** TI defines "RoHS" to mean semiconductor products that are compliant with the current EU RoHS requirements for all 10 RoHS substances, including the requirement that RoHS substance do not exceed 0.1% by weight in homogeneous materials. Where designed to be soldered at high temperatures, "RoHS" products are suitable for use in specified lead-free processes. TI may reference these types of products as "Pb-Free".

RoHS Exempt: TI defines "RoHS Exempt" to mean products that contain lead but are compliant with EU RoHS pursuant to a specific EU RoHS exemption.

Green: TI defines "Green" to mean the content of Chlorine (Cl) and Bromine (Br) based flame retardants meet JS709B low halogen requirements of <=1000ppm threshold. Antimony trioxide based flame retardants must also meet the <=1000ppm threshold requirement.

(3) MSL, Peak Temp. - The Moisture Sensitivity Level rating according to the JEDEC industry standard classifications, and peak solder temperature.

(4) There may be additional marking, which relates to the logo, the lot trace code information, or the environmental category on the device.

(5) Multiple Device Markings will be inside parentheses. Only one Device Marking contained in parentheses and separated by a "~" will appear on a device. If a line is indented then it is a continuation of the previous line and the two combined represent the entire Device Marking for that device.

(6) Lead finish/Ball material - Orderable Devices may have multiple material finish options. Finish options are separated by a vertical ruled line. Lead finish/Ball material values may wrap to two lines if the finish value exceeds the maximum column width.

Important Information and Disclaimer:The information provided on this page represents TI's knowledge and belief as of the date that it is provided. TI bases its knowledge and belief on information provided by third parties, and makes no representation or warranty as to the accuracy of such information. Efforts are underway to better integrate information from third parties. TI has taken and continues to take reasonable steps to provide representative and accurate information but may not have conducted destructive testing or chemical analysis on incoming materials and chemicals. TI and TI suppliers consider certain information to be proprietary, and thus CAS numbers and other limited information may not be available for release.

In no event shall TI's liability arising out of such information exceed the total purchase price of the TI part(s) at issue in this document sold by TI to Customer on an annual basis.

OTHER QUALIFIED VERSIONS OF TLV5619-EP :

- Catalog: [TLV5619](#)

NOTE: Qualified Version Definitions:

- Catalog - TI's standard catalog product

TAPE AND REEL INFORMATION

QUADRANT ASSIGNMENTS FOR PIN 1 ORIENTATION IN TAPE

*All dimensions are nominal

Device	Package Type	Package Drawing	Pins	SPQ	Reel Diameter (mm)	Reel Width W1 (mm)	A0 (mm)	B0 (mm)	K0 (mm)	P1 (mm)	W (mm)	Pin1 Quadrant
TLV5619QDWREP	SOIC	DW	20	2000	330.0	24.4	10.8	13.3	2.7	12.0	24.0	Q1

TAPE AND REEL BOX DIMENSIONS

*All dimensions are nominal

Device	Package Type	Package Drawing	Pins	SPQ	Length (mm)	Width (mm)	Height (mm)
TLV5619QDWREP	SOIC	DW	20	2000	350.0	350.0	43.0

DW0020A



PACKAGE OUTLINE

SOIC - 2.65 mm max height

SOIC



4220724/A 05/2016

NOTES:

1. All linear dimensions are in millimeters. Dimensions in parenthesis are for reference only. Dimensioning and tolerancing per ASME Y14.5M.
2. This drawing is subject to change without notice.
3. This dimension does not include mold flash, protrusions, or gate burrs. Mold flash, protrusions, or gate burrs shall not exceed 0.15 mm per side.
4. This dimension does not include interlead flash. Interlead flash shall not exceed 0.43 mm per side.
5. Reference JEDEC registration MS-013.

EXAMPLE BOARD LAYOUT

DW0020A

SOIC - 2.65 mm max height

SOIC



LAND PATTERN EXAMPLE
SCALE:6X



SOLDER MASK DETAILS

4220724/A 05/2016

NOTES: (continued)

- 6. Publication IPC-7351 may have alternate designs.
- 7. Solder mask tolerances between and around signal pads can vary based on board fabrication site.

EXAMPLE STENCIL DESIGN

DW0020A

SOIC - 2.65 mm max height

SOIC



SOLDER PASTE EXAMPLE
BASED ON 0.125 mm THICK STENCIL
SCALE:6X

4220724/A 05/2016

NOTES: (continued)

8. Laser cutting apertures with trapezoidal walls and rounded corners may offer better paste release. IPC-7525 may have alternate design recommendations.
9. Board assembly site may have different recommendations for stencil design.

IMPORTANT NOTICE AND DISCLAIMER

TI PROVIDES TECHNICAL AND RELIABILITY DATA (INCLUDING DATA SHEETS), DESIGN RESOURCES (INCLUDING REFERENCE DESIGNS), APPLICATION OR OTHER DESIGN ADVICE, WEB TOOLS, SAFETY INFORMATION, AND OTHER RESOURCES "AS IS" AND WITH ALL FAULTS, AND DISCLAIMS ALL WARRANTIES, EXPRESS AND IMPLIED, INCLUDING WITHOUT LIMITATION ANY IMPLIED WARRANTIES OF MERCHANTABILITY, FITNESS FOR A PARTICULAR PURPOSE OR NON-INFRINGEMENT OF THIRD PARTY INTELLECTUAL PROPERTY RIGHTS.

These resources are intended for skilled developers designing with TI products. You are solely responsible for (1) selecting the appropriate TI products for your application, (2) designing, validating and testing your application, and (3) ensuring your application meets applicable standards, and any other safety, security, regulatory or other requirements.

These resources are subject to change without notice. TI grants you permission to use these resources only for development of an application that uses the TI products described in the resource. Other reproduction and display of these resources is prohibited. No license is granted to any other TI intellectual property right or to any third party intellectual property right. TI disclaims responsibility for, and you will fully indemnify TI and its representatives against, any claims, damages, costs, losses, and liabilities arising out of your use of these resources.

TI's products are provided subject to [TI's Terms of Sale](#) or other applicable terms available either on [ti.com](https://www.ti.com) or provided in conjunction with such TI products. TI's provision of these resources does not expand or otherwise alter TI's applicable warranties or warranty disclaimers for TI products.

TI objects to and rejects any additional or different terms you may have proposed.

Mailing Address: Texas Instruments, Post Office Box 655303, Dallas, Texas 75265
Copyright © 2023, Texas Instruments Incorporated

Looking for pricing, stock, or lifecycle information?

Click below to explore more details on WIN SOURCE:

 [View TLV5619QDWREP on WIN SOURCE](#)

 [Texas Instruments](#) Information

Optimize Your Supply Chain with WIN SOURCE Solutions

-  Global Sourcing Solution
-  Obsolete Management
-  Cost Control Management
-  Shortage Management
-  Alternative Solution
-  Excess Inventory Management