



# THE DATASHEET OF TLC59283RGET



# 16-Channel, Constant-Current LED Driver With Pre-Charge FET

## 1 Features

- 16-channel, constant-current sink output with on and off control
- Constant-current sink capability: 35mA ( $V_{CC} \leq 3.6V$ ), 45mA ( $V_{CC} > 3.6V$ )
- LED power-supply voltage: up to 10V
- $V_{CC} = 3V$  to 5.5V
- Constant-current accuracy:
  - Channel-to-channel:  $\pm 1.4\%$  (typ),  $\pm 3\%$  (max)
  - Device-to-device:  $\pm 2\%$  (typ),  $\pm 4\%$  (max)
- CMOS logic level I/O
- Data transfer rate: 35MHz
- BLANK pulse width: 50ns
- Pre-charge FET for ghosting reduction
- Grouped switching delay for noise reduction
- Operating temperature:  $-40^{\circ}C$  to  $+85^{\circ}C$

## 2 Applications

- Video displays
- Message boards

## 3 Description

The TLC59283 is a 16-channel, constant-current sink light-emitting diode (LED) driver. Each channel can be individually controlled with a simple serial communications protocol that is compatible with 3.3V or 5V CMOS logic levels, depending on the operating VCC. When the serial data buffer is loaded, a LAT rising edge transfers the data to the  $OUT_n$  outputs. The BLANK pin can be used to turn off all  $OUT_n$  outputs during power-on and output data latching to prevent unwanted image displays during these times. The constant-current value of all 16 channels is set by a single external resistor.

Each constant-current output has a pre-charge field-effect transistor (FET) that can reduce ghosting on the multiplexing (dynamic) drive LED display. Multiple TLC59283s can be cascaded together to control additional LEDs from the same processor.

### Package Information

PART NUMBER	PACKAGE <sup>(1)</sup>
TLC59283	DB (SSOP, 24)
	DBQ (QSOP, 24)
TLC59283	RGE (QFN, 24)

(1) For more information, see [Section 12](#).

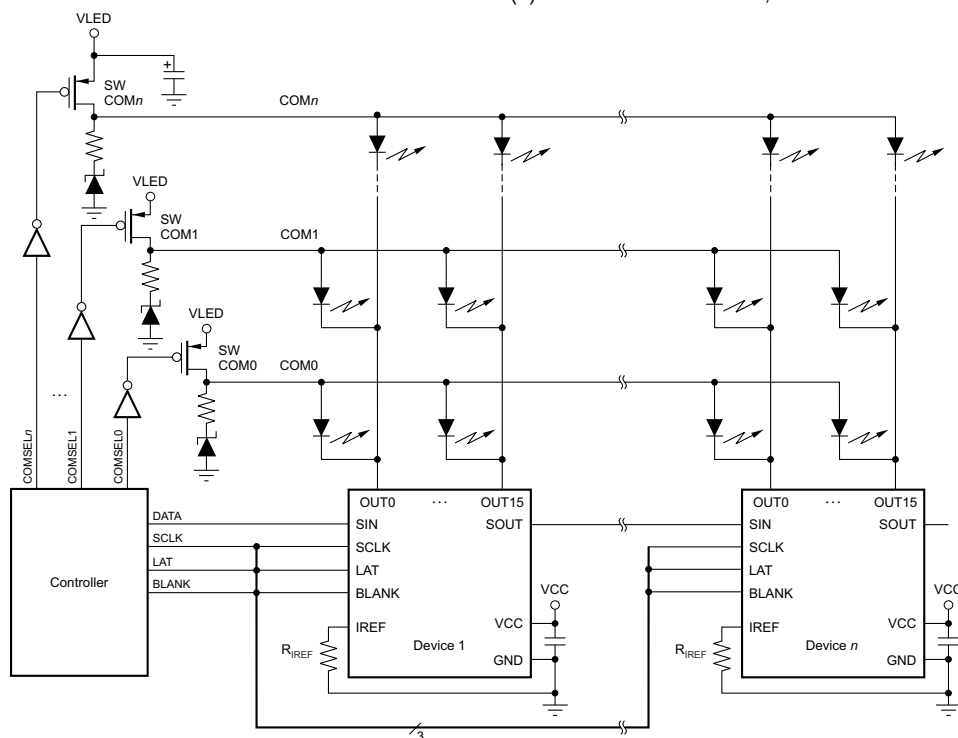

**Typical Application Circuit (Multiple Daisy-Chained TLC59283s)**



## Table of Contents

<b>1 Features</b> .....	1	7.2 Functional Block Diagram.....	15
<b>2 Applications</b> .....	1	7.3 Feature Description.....	16
<b>3 Description</b> .....	1	<b>8 Register Configuration</b> .....	19
<b>4 Pin Configurations</b> .....	3	<b>9 Application and Implementation</b> .....	21
<b>5 Specifications</b> .....	5	9.1 Application Information.....	21
5.1 Absolute Maximum Ratings.....	5	9.2 Typical Application.....	21
5.2 Storage Conditions.....	5	9.3 Power Supply Recommendations.....	24
5.3 ESD Ratings.....	5	9.4 Layout.....	24
5.4 Recommended Operating Conditions.....	6	<b>10 Device and Documentation Support</b> .....	25
5.5 Thermal Information.....	6	10.1 Third-Party Products Disclaimer.....	25
5.6 Electrical Characteristics.....	7	10.2 Documentation Support.....	25
5.7 Timing Characteristics.....	8	10.3 Receiving Notification of Documentation Updates..	25
5.8 Timing Diagrams.....	9	10.4 Support Resources.....	25
5.9 Typical Characteristics.....	11	10.5 Trademarks.....	25
<b>6 Parameter Measurement Information</b> .....	13	10.6 Electrostatic Discharge Caution.....	25
6.1 Pin-equivalent Input and Output Schematic Diagrams.....	13	10.7 Glossary.....	25
6.2 Test Circuits.....	14	<b>11 Revision History</b> .....	26
<b>7 Detailed Description</b> .....	15	<b>12 Mechanical, Packaging, and Orderable Information</b> .....	27
7.1 Overview.....	15		

## 4 Pin Configurations

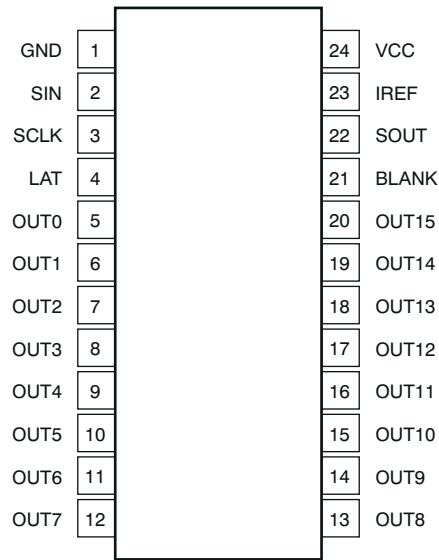

**Figure 4-1. DBQ Package SSOP-24 and QSOP-24 (top view)**

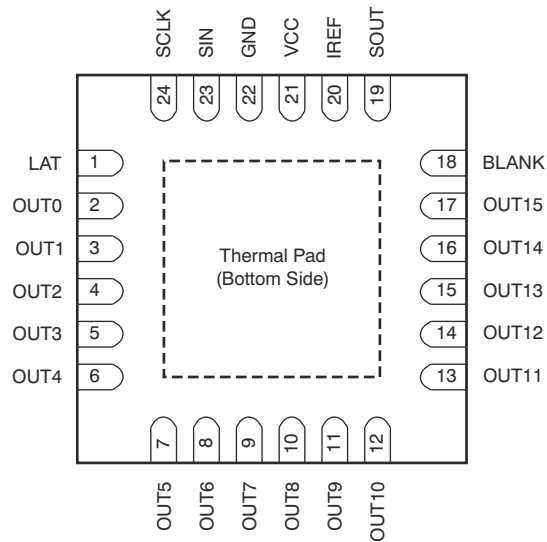

**Figure 4-2. RGE Package QFN-24 (top view)**

NOTE: Thermal pad is not connected to GND internally. The thermal pad must be connected to GND with the printed circuit board (PCB) pattern.

**Table 4-1. Pin Functions**

NAME	PIN		I/O	DESCRIPTION
	NUMBER			
	DBQ	RGE		
BLANK	21	18	I	All outputs empty (blank); Schmitt buffer input. When BLANK is high, all constant-current outputs (OUT0 to OUT15) are forced off and all pre-charge FETs are turned on. When BLANK is low, all constant-current outputs are controlled by the data in the output on or off data latch and all pre-charge FETs are turned off. This pin is internally pulled up to $V_{CC}$ with a 500k $\Omega$ (typ) resistor.
GND	1	22	—	Power ground
IREF	23	20	I/O	Constant-current value setting, the OUT0 to OUT15 sink constant-current outputs are set to the desired values by connecting an external resistor between IREF and GND.
LAT	4	1	I	Level-triggered latch; Schmitt buffer input. The data in the 16-bit shift register continue to transfer to the output on or off data latch while LAT is high. Therefore, if the data in the 16-bit shift register are changed when LAT is high, the data in the data latch are also changed. The data in the data latch are held when LAT is low. This pin is internally pulled down to GND with a 500k $\Omega$ (typ) resistor.
OUT0	5	2	O	Constant-current output. Each output can be tied together with others to increase the constant-current. Different voltages can be applied to each output.
OUT1	6	3	O	Constant-current output
OUT2	7	4	O	Constant-current output
OUT3	8	5	O	Constant-current output
OUT4	9	6	O	Constant-current output
OUT5	10	7	O	Constant-current output
OUT6	11	8	O	Constant-current output
OUT7	12	9	O	Constant-current output
OUT8	13	10	O	Constant-current output
OUT9	14	11	O	Constant-current output
OUT10	15	12	O	Constant-current output
OUT11	16	13	O	Constant-current output
OUT12	17	14	O	Constant-current output
OUT13	18	15	O	Constant-current output
OUT14	19	16	O	Constant-current output
OUT15	20	17	O	Constant-current output
SCLK	3	24	I	Serial data shift clock; Schmitt buffer input. All data in the 16-bit shift register are shifted toward the MSB by a 1-bit SCLK synchronization.
SIN	2	23	I	Serial data input for driver on or off control; Schmitt buffer input. When SIN is high, the LSB is set to '1' for only one SCLK input rising edge. If two SCLK rising edges are input while SIN is high, then the 16-bit shift register LSB and LSB+1 are set to '1'. When SIN is low, the LSB is set to '0' at the SCLK input rising edge.
SOUT	22	19	O	Serial data output. This output is connected to the 16-bit shift register MSB. SOUT data changes at the SCLK rising edge.
VCC	24	21	—	Power-supply voltage

## 5 Specifications

### 5.1 Absolute Maximum Ratings

Over operating free-air temperature range, unless otherwise noted.<sup>(1)</sup>

			VALUE		UNIT <sup>(2)</sup>
			MIN	MAX	
Voltage	V <sub>CC</sub>	Supply	-0.3	+6	V
	V <sub>IN</sub>	Input range, SIN, SCLK, LAT, BLANK, IREF	-0.3	V <sub>CC</sub> + 0.3	V
	V <sub>OUT</sub>	Output range, SOUT	-0.3	V <sub>CC</sub> + 0.3	V
		Output range, OUT0 to OUT15	-0.3	+11	V
Current	I <sub>OUT</sub>	Output (dc), OUT0 to OUT15		+50	mA
Temperature	T <sub>J(MAX)</sub>	Operating junction		+150	°C
	T <sub>stg</sub>	Storage range		-55	+150

- (1) Operation outside the Absolute Maximum Ratings may cause permanent device damage. Absolute Maximum Ratings do not imply functional operation of the device at these or any other conditions beyond those listed under Recommended Operating Conditions. If used outside the Recommended Operating Conditions but within the Absolute Maximum Ratings, the device may not be fully functional, and this may affect device reliability, functionality, performance, and shorten the device lifetime.
- (2) All voltage values are with respect to network ground terminal.

### 5.2 Storage Conditions

applicable before the DMD is installed in the final product

		MIN	MAX	UNIT
T <sub>stg</sub>	DMD storage temperature	-55	+150	°C

### 5.3 ESD Ratings

			VALUE	UNIT
V <sub>(ESD)</sub>	Electrostatic discharge	Human-body model (HBM), per ANSI/ESDA/JEDEC JS-001 <sup>1</sup>	±3000	V
		Charged device model (CDM), per ANSI/ESDA/JEDEC JS-002 <sup>2</sup>	±2000	

## 5.4 Recommended Operating Conditions

At  $T_A = -40^\circ\text{C}$  to  $+85^\circ\text{C}$ , unless otherwise noted.

PARAMETER			TEST CONDITIONS	TLC59283		UNIT
				MIN	MAX	
<b>DC CHARACTERISTICS (<math>V_{CC} = 3\text{ V to }5.5\text{ V}</math>)</b>						
$V_{CC}$	Supply voltage			3	5.5	V
$V_O$	Voltage applied to output		OUT0 to OUT15		10	V
$V_{IH}$	Input voltage	High	SIN, SCLK, LAT, BLANK	$0.7 \times V_{CC}$	$V_{CC}$	V
$V_{IL}$		Low	SIN, SCLK, LAT, BLANK	GND	$0.3 \times V_{CC}$	V
$I_{OH}$	Output current	High	SOUT		-2	mA
$I_{OL}$		Low	SOUT		2	mA
$I_{OLC}$	Constant output sink current		OUT0 to OUT15, $3\text{ V} \leq V_{CC} \leq 3.6\text{ V}$	2	35	mA
			OUT0 to OUT15, $3.6\text{ V} < V_{CC} \leq 5.5\text{ V}$	2	45	mA
$T_A$	Temperature range	Operating free-air		-40	+85	$^\circ\text{C}$
$T_J$		Operating junction		-40	+125	$^\circ\text{C}$
<b>AC CHARACTERISTICS (<math>V_{CC} = 3\text{ V to }5.5\text{ V}</math>)</b>						
$f_{CLK}$ (SCLK)	Data shift clock frequency		SCLK		35	MHz
$t_{WH0}$	Pulse duration		SCLK	10		ns
$t_{WL0}$			SCLK	10		ns
$t_{WH1}$			LAT	20		ns
$t_{WH2}$			BLANK	100		ns
$t_{WL2}$			BLANK	50		ns
$t_{SU0}$	Setup time		SIN $\uparrow$ – SCLK $\uparrow$	4		ns
$t_{SU1}$			LAT $\downarrow$ – SCLK $\uparrow$	10		ns
$t_{H0}$	Hold time		SIN $\uparrow$ – SCLK $\uparrow$	4		ns
$t_{H1}$			LAT $\downarrow$ – SCLK $\uparrow$	10		ns

## 5.5 Thermal Information

THERMAL METRIC			TLC59283		UNITS
			DBQ	RGE	
			24 PINS	24 PINS	
$\theta_{JA}$	Junction-to-ambient thermal resistance		91.5	42.9	$^\circ\text{C/W}$
$\theta_{Jc\text{top}}$	Junction-to-case (top) thermal resistance		55.2	55.3	
$\theta_{JB}$	Junction-to-board thermal resistance		44.9	21.7	
$\psi_{JT}$	Junction-to-top characterization parameter		16.8	1.9	
$\psi_{JB}$	Junction-to-board characterization parameter		44.5	21.8	
$\theta_{Jc\text{bot}}$	Junction-to-case (bottom) thermal resistance		N/A	8.8	

## 5.6 Electrical Characteristics

All minimum and maximum specifications are at  $T_A = -40^\circ\text{C}$  to  $+85^\circ\text{C}$  and  $V_{CC} = 3\text{V}$  to  $5.5\text{V}$ , unless otherwise noted. Typical specifications are at  $T_A = +25^\circ\text{C}$  and  $V_{CC} = 3.3\text{V}$ .

PARAMETER			TEST CONDITIONS	TLC59283			UNIT		
				MIN	TYP	MAX			
$V_{OH}$	Output voltage	High	$I_{OH} = -2\text{mA}$ at SOUT	$V_{CC} - 0.4$		$V_{CC}$	V		
$V_{OL}$		Low	$I_{OL} = 2\text{mA}$ at SOUT			0.4	V		
$V_{PCHG}$	Pre-charged voltage		$I_O = -10\mu\text{A}$	$V_{CC} - 2.0$	$V_{CC} - 1.4$	$V_{CC} - 0.8$	V		
$V_{IREF}$	Reference voltage output		$R_{IREF} = 1.5\text{k}\Omega$ , $T_A = +25^\circ\text{C}$		1.208		V		
$I_{IN}$	Input current		$V_{IN} = V_{CC}$ or GND at SIN and SCLK	-1		1	$\mu\text{A}$		
$I_{CC0}$	Supply current ( $V_{CC}$ )		SIN, SCLK, LAT = GND, BLANK = $V_{OUTn} = V_{CC}$ , $R_{IREF} = \text{open}$		1	2	mA		
$I_{CC1}$			SIN, SCLK, LAT = GND, BLANK = $V_{OUTn} = V_{CC}$ , $R_{IREF} = 3\text{k}\Omega$ ( $I_{OUT} = 17.6\text{mA}$ target)		3	4	mA		
$I_{CC2}$			All $OUTn = \text{ON}$ , SIN, SCLK, LAT, BLANK = GND, $V_{OUTn} = 0.8\text{V}$ , $R_{IREF} = 3\text{k}\Omega$		7	9	mA		
$I_{CC3}$			All $OUTn = \text{ON}$ , SIN, SCLK, LAT, BLANK = GND, $V_{OUTn} = 0.8\text{V}$ , $R_{IREF} = 1.5\text{k}\Omega$ ( $I_{OUT} = 35.3\text{mA}$ target)		8	11	mA		
$I_{OLC}$	Constant output current		All $OUTn = \text{ON}$ , $V_{OUTn} = V_{OUTfix} = 0.8\text{V}$ , $R_{IREF} = 1.5\text{k}\Omega$ , $T_A = +25^\circ\text{C}$ (see <a href="#">Figure 6-8</a> )	32.9	35.3	37.7	mA		
$I_{OLKG0}$	Output leakage current		All $OUTn = \text{OFF}$ , $V_{OUTn} = V_{OUTfix} = 10\text{V}$ , BLANK = $V_{CC}$ , $R_{IREF} = 1.5\text{k}\Omega$ (see <a href="#">Figure 6-8</a> )				0.1	$\mu\text{A}$	
				$T_J = +25^\circ\text{C}$				0.2	$\mu\text{A}$
				$T_J = +85^\circ\text{C}$				0.07	0.5
$\Delta I_{OLC0}$	Constant-current error	Channel-to-channel <sup>(1)</sup>	All $OUTn = \text{ON}$ , $V_{OUTn} = V_{OUTfix} = 0.8\text{V}$ , $R_{IREF} = 1.5\text{k}\Omega$ , $T_A = +25^\circ\text{C}$ (see <a href="#">Figure 6-8</a> )		$\pm 1.4$		$\pm 3$	%	
		Device-to-device <sup>(2)</sup>	All $OUTn = \text{ON}$ , $V_{OUTn} = V_{OUTfix} = 0.8\text{V}$ , $R_{IREF} = 1.5\text{k}\Omega$ , $T_A = +25^\circ\text{C}$ (see <a href="#">Figure 6-8</a> )		$\pm 2$		$\pm 4$	%	
$\Delta I_{OLC2}$	Line regulation <sup>(3)</sup>		All $OUTn = \text{ON}$ , $V_{OUTn} = V_{OUTfix} = 0.8\text{V}$ , $R_{IREF} = 1.5\text{k}\Omega$ , $V_{CC} = 3\text{V}$ to $5.5\text{V}$		$\pm 0.05$		$\pm 1$	%/V	
$\Delta I_{OLC3}$	Load regulation <sup>(4)</sup>		All $OUTn = \text{ON}$ , $V_{OUTn} = 0.8\text{V}$ to $3\text{V}$ , $V_{OUTfix} = 0.8\text{V}$ , $R_{IREF} = 1.5\text{k}\Omega$		$\pm 0.5$		$\pm 1$	%/V	
$R_{PUP}$	Resistor	Pull-up	BLANK	250	500	750	k $\Omega$		
$R_{PDWN}$		Pull-down	LAT	250	500	750	k $\Omega$		
$R_{PCHG}$	Pre-charge FET on-resistance		$V_{CC} = 5.0\text{V}$ , $V_{OUTn} = 0\text{V}$ , OUT0 to OUT15, BLANK = $V_{CC}$ , $T_A = +25^\circ\text{C}$		3	6	k $\Omega$		

- (1) The deviation of each output from the average of OUT0 to OUT15 constant-current. Deviation is calculated by the formula:

$$\Delta (\%) = \left[ \frac{I_{OUTn}}{\frac{(I_{OUT0} + I_{OUT1} + \dots + I_{OUT14} + I_{OUT15})}{16}} - 1 \right] \times 100$$

- (2) The deviation of the OUT0 to OUT15 constant-current average from the ideal constant-current value. Deviation is calculated by the following formula:

$$\Delta (\%) = \left[ \frac{\frac{(I_{OUT0} + I_{OUT1} + \dots + I_{OUT14} + I_{OUT15})}{16} - (\text{Ideal Output Current})}{\text{Ideal Output Current}} \right] \times 100$$

Ideal current is calculated by the formula:

$$I_{OUT(\text{IDEAL})} = 43.8 \times \left[ \frac{1.208\text{V}}{R_{IREF}} \right]$$

- (3) Line regulation is calculated by this equation:

$$\Delta (\%/V) = \left[ \frac{(I_{OUTn} \text{ at } V_{CC} = 5.5\text{V}) - (I_{OUTn} \text{ at } V_{CC} = 3\text{V})}{(I_{OUTn} \text{ at } V_{CC} = 3\text{V})} \right] \times \frac{100}{5.5\text{V} - 3\text{V}}$$

- (4) Load regulation is calculated by the equation:

$$\Delta (\%/V) = \left[ \frac{(I_{OUTn} \text{ at } V_{OUTn} = 3\text{V}) - (I_{OUTn} \text{ at } V_{OUTn} = 1\text{V})}{(I_{OUTn} \text{ at } V_{OUTn} = 1\text{V})} \right] \times \frac{100}{3\text{V} - 1\text{V}}$$

## 5.7 Timing Characteristics

All minimum and maximum specifications are at  $T_A = -40^\circ\text{C}$  to  $+85^\circ\text{C}$ ,  $V_{CC} = 3\text{V}$  to  $5.5\text{V}$ ,  $C_L = 15\text{pF}$ ,  $R_L = 110\Omega$ ,  $R_{IREF} = 1.5\text{k}\Omega$ , and  $V_{LED} = 5.0\text{V}$ , unless otherwise noted. Typical values are at  $T_A = +25^\circ\text{C}$  and  $V_{CC} = 3.3\text{V}$ .

PARAMETER		TEST CONDITIONS	TLC59283			UNIT
			MIN	TYP	MAX	
$t_{R0}$	Rise time	SOUT (see Figure 6-7)		3	10	ns
$t_{R1}$		OUT $n$ (see Figure 6-6)		44		ns
$t_{F0}$	Fall time	SOUT (see Figure 6-7)		3	10	ns
$t_{F1}$		OUT $n$ (see Figure 6-6)		44		ns
$t_{D0}$	Propagation delay time	SCLK $\uparrow$ to SOUT $\uparrow\downarrow$		11	20	ns
$t_{D1}$		LAT $\uparrow$ or BLANK $\uparrow\downarrow$ to OUT0 on or off, $T_A = +25^\circ\text{C}$		60	100	ns
$t_{D2}$		Grouped OUT $n$ on or off to next group on or off, $T_A = +25^\circ\text{C}$		2		ns
$t_{ON\_ERR}$	Output on-time error <sup>(1)</sup>	Output on or off latch data = all '1', 50ns BLANK GND level pulse, $V_{CC} = 3.3\text{V}$ , $T_A = +25^\circ\text{C}$		-45	45	ns

- (1) Output on-time error ( $t_{ON\_ERR}$ ) is calculated by the formula:  $t_{ON\_ERR}$  (ns) =  $t_{OUT\_ON}$  – BLANK low level one-shot pulse width ( $t_{WL2}$ ).  $t_{OUT\_ON}$  indicates the actual on-time of the constant-current output.

### 5.8 Timing Diagrams

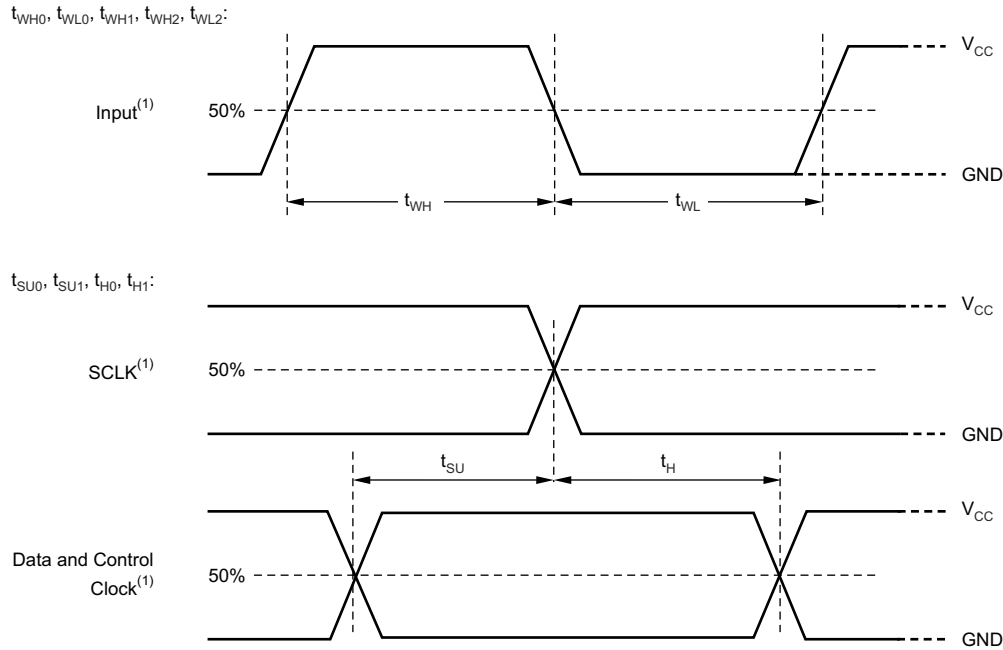

A. Input pulse rise and fall time is 1ns to 3ns.

**Figure 5-1. Input Timing Diagram**

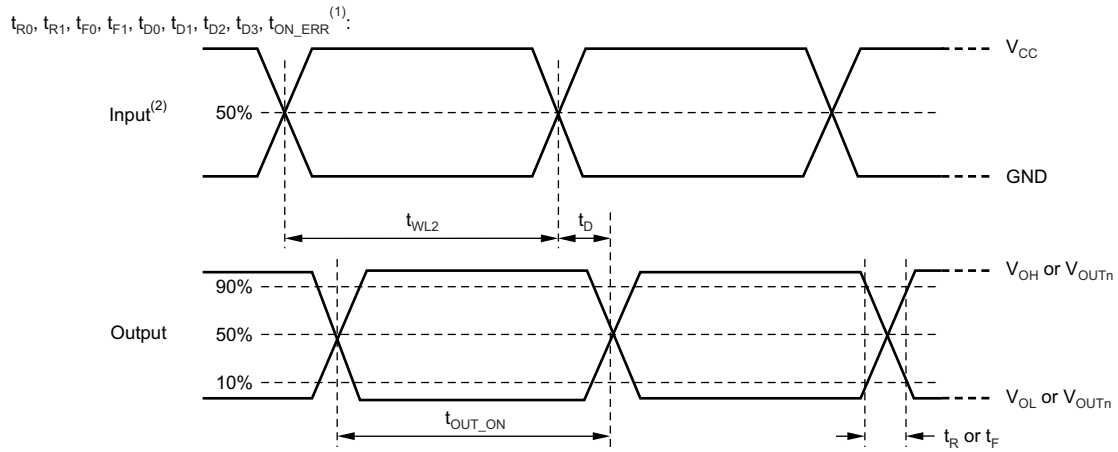

A.  $t_{ON\_ERR}$  is calculated by  $t_{OUTON} - t_{WL2}$ .

B. Input pulse rise and fall time is 1ns to 3ns.

**Figure 5-2. Output Timing Diagram**

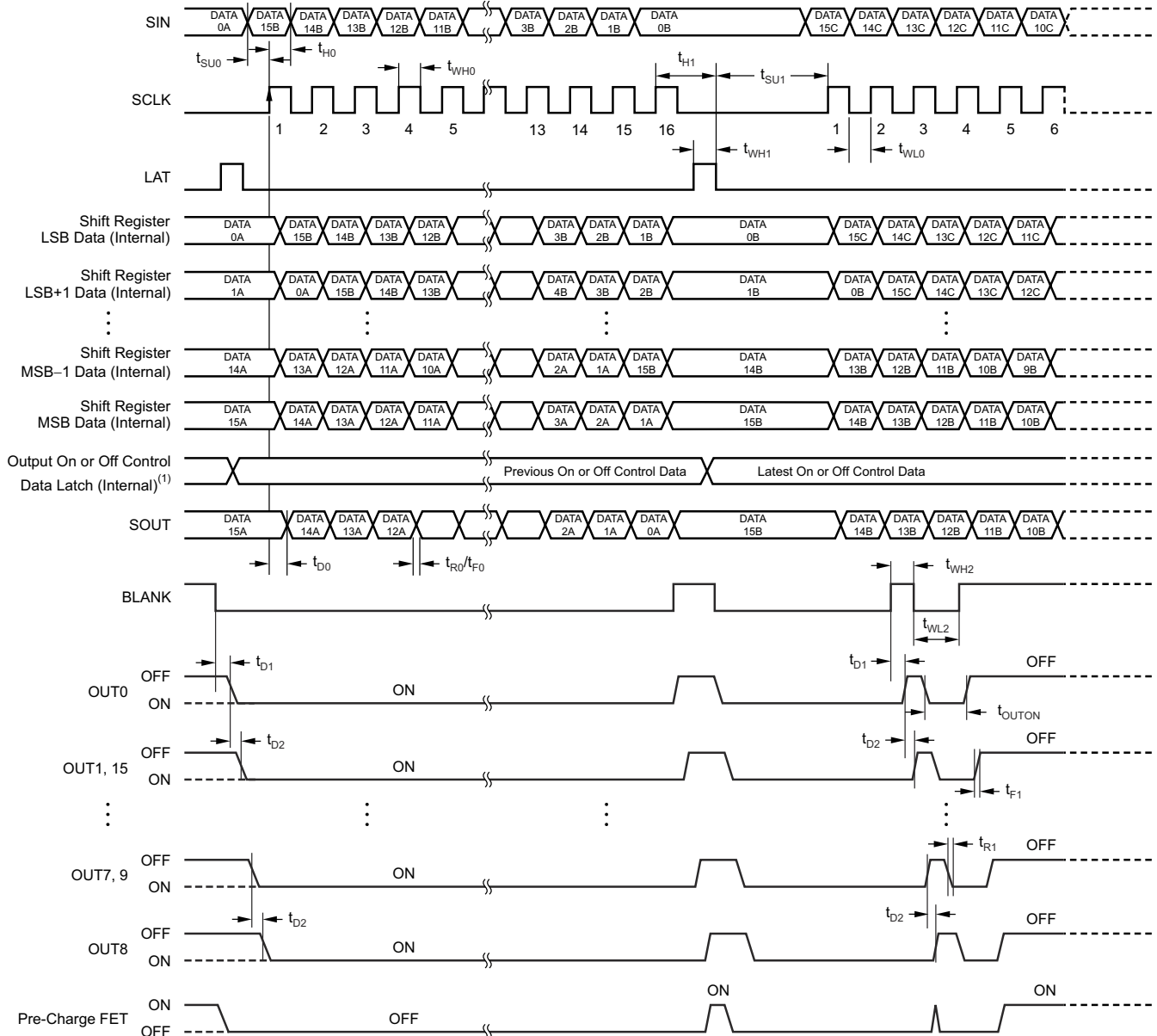

A. Output on or off data = FFFFh.

B.  $t_{ON\_ERR} = t_{OUTON} - t_{WL2}$ .

Figure 5-3. Data Write and Output On or Off Timing Diagram

### 5.9 Typical Characteristics

At  $T_A = +25^\circ\text{C}$  and  $V_{CC} = 3.3\text{V}$ , unless otherwise noted.

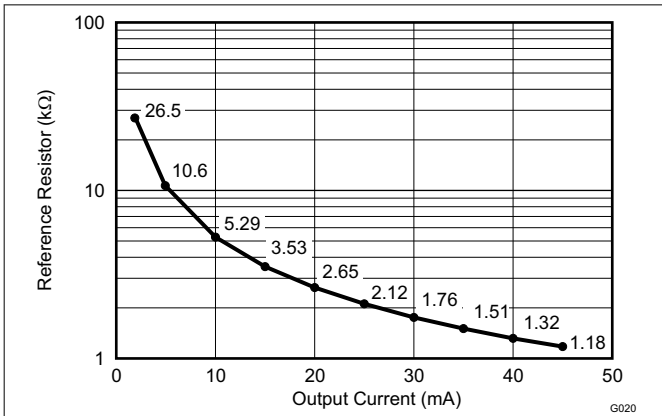

Figure 5-4. Reference Resistor vs Output Current

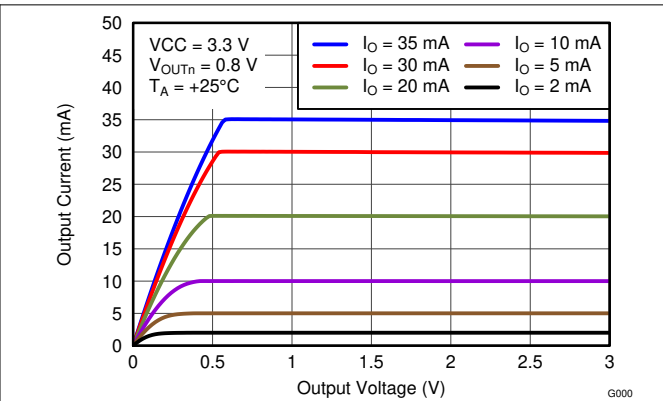

Figure 5-5. Output Current vs Output Voltage ( $V_{CC} = 3.3\text{V}$ )

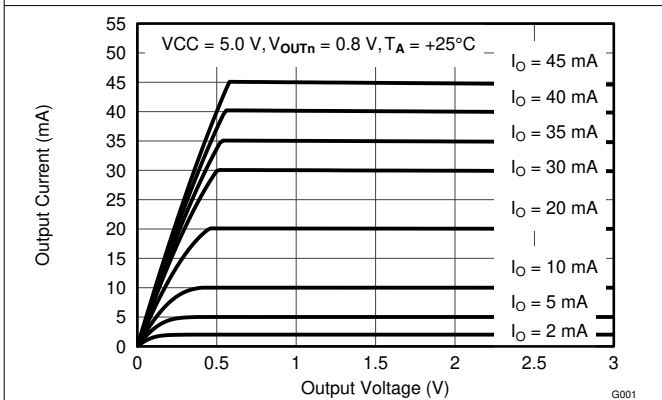

Figure 5-6. Output Current vs Output Voltage ( $V_{CC} = 5.0\text{V}$ )

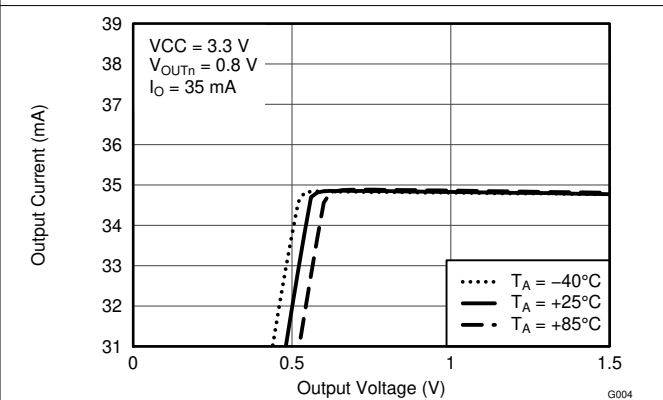

Figure 5-7. Output Current vs Output Voltage ( $V_{CC} = 3.3\text{V}$ , Magnified)

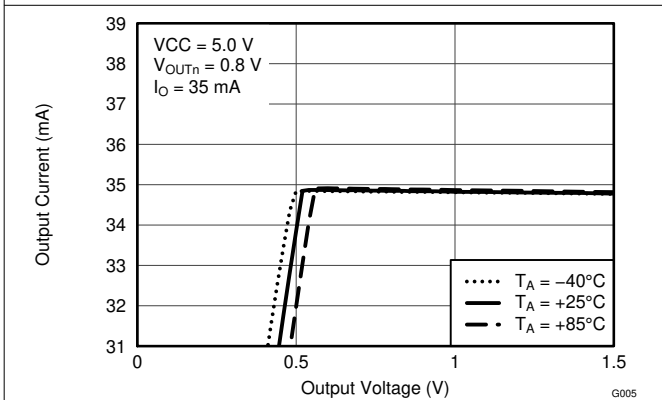

Figure 5-8. Output Current vs Output Voltage ( $V_{CC} = 5.0\text{V}$ , Magnified)

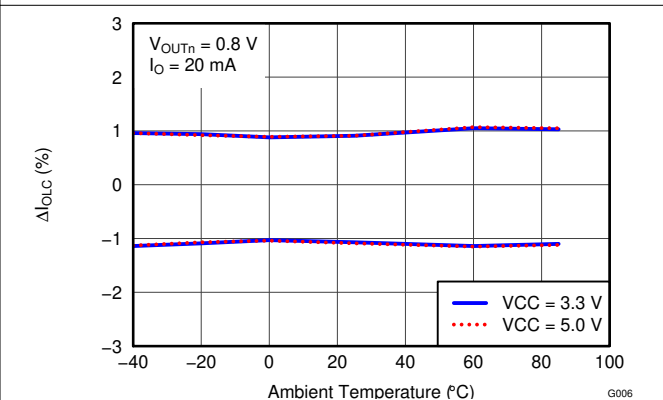
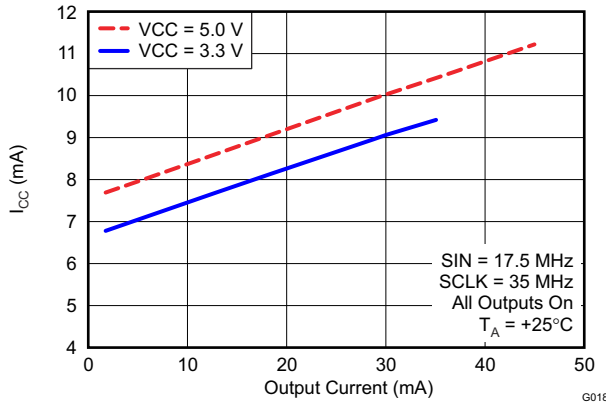
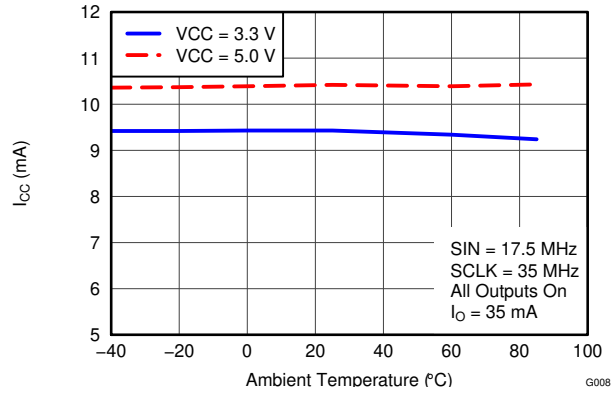

Figure 5-9.  $\Delta I_{OLC}$  vs Ambient Temperature



**Figure 5-10. Supply Current vs Output Current**



**Figure 5-11. Supply Current vs Ambient Temperature**

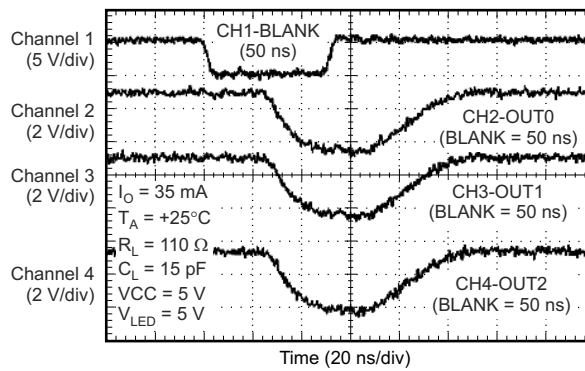

**Figure 5-12. Constant-current Output Voltage Waveform**

## 6 Parameter Measurement Information

### 6.1 Pin-equivalent Input and Output Schematic Diagrams

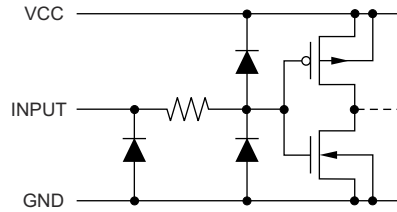

**Figure 6-1. SIN and SCLK**

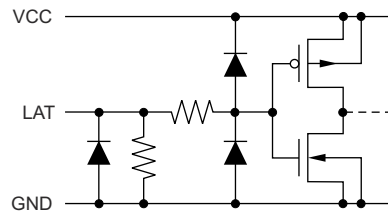

**Figure 6-2. LAT**

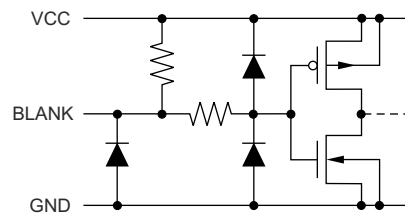

**Figure 6-3. BLANK**

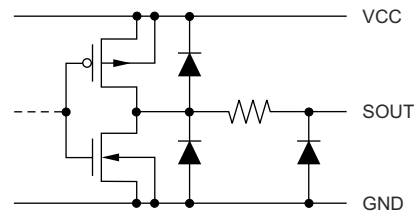

**Figure 6-4. SOUT**

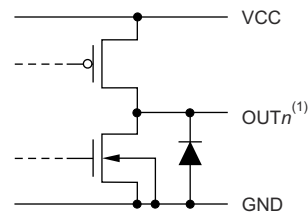

A.  $n = 0$  to 15.

**Figure 6-5. OUT0 Through OUT15**

## 6.2 Test Circuits

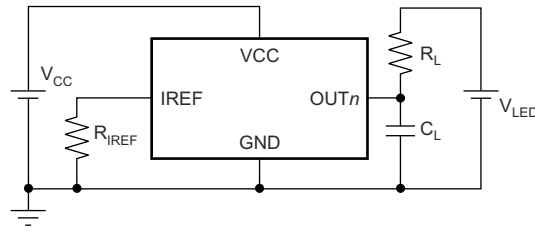

**Figure 6-6. OUT $n$  Rise and Fall Time Test Circuit**

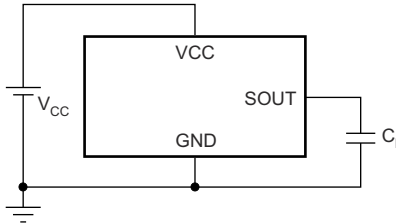

**Figure 6-7. SOUT Rise and Fall Time Test Circuit**

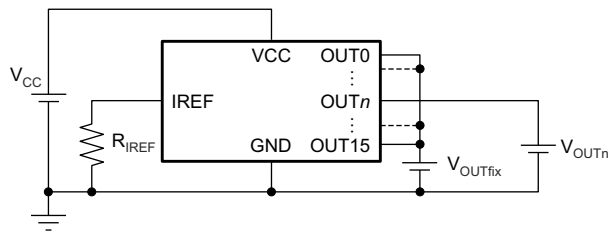

**Figure 6-8. OUT $n$  Constant-current Test Circuit**

## 7 Detailed Description

### 7.1 Overview

The TLC59283 is a 16-channel, constant-current sink light-emitting diode (LED) driver. Each channel can be individually controlled with a simple serial communications protocol that is compatible with 3.3V or 5V CMOS logic levels, depending on the operating VCC. When the serial data buffer is loaded, a LAT rising edge transfers the data to the OUTn outputs. The BLANK pin can be used to turn off all OUTn outputs during power-on and output data latching to prevent unwanted image displays during these times. The constant-current value of all 16 channels is set by a single external resistor.

Each constant-current output has a pre-charge field effect transistor (FET) that can reduce ghosting on the multiplexing (dynamic) drive LED display. Multiple TLC59283s can be cascaded together to control additional LEDs from the same processor.

### 7.2 Functional Block Diagram

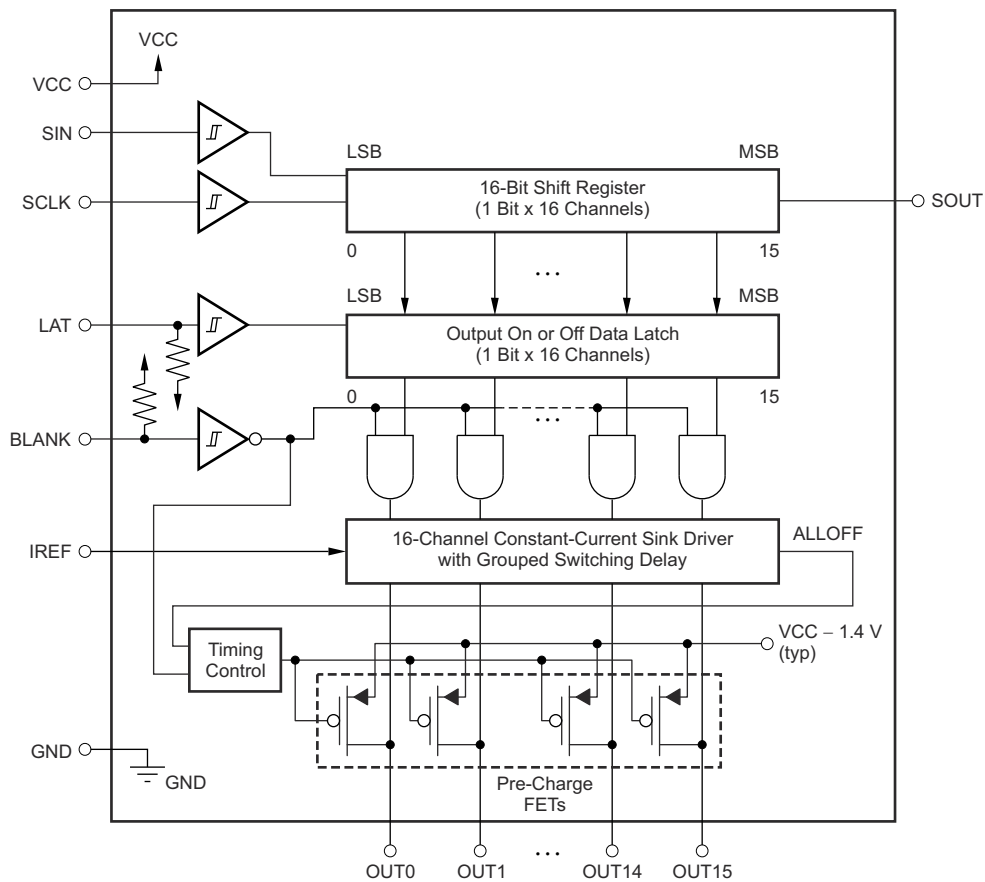

## 7.3 Feature Description

### 7.3.1 Constant Sink Current Value Setting

The constant-current values are determined by an external resistor ( $R_{IREF}$ ) placed between IREF and GND. The resistor ( $R_{IREF}$ ) value is calculated by [Equation 1](#).

$$R_{IREF} \text{ (k}\Omega\text{)} = \frac{V_{IREF} \text{ (V)}}{I_{OLC} \text{ (mA)}} \times 43.8 \quad (1)$$

Where:

$V_{IREF}$  = the internal reference voltage on the IREF pin (typically 1.208V)

$I_{OLC}$  must be set in the range of 2mA to 35mA when  $V_{CC}$  is less than 3.6V. Also, when  $V_{CC}$  is equal to 3.6V or greater,  $I_{OLC}$  must be set in the range of 2mA to 45mA. The constant sink current characteristic for the external resistor value is illustrated in [Figure 5-4](#). [Table 7-1](#) describes the constant-current output versus external resistor value.

**Table 7-1. Constant-current Output Versus External Resistor Value**

$I_{OLC}$ (mA)	$R_{IREF}$ (k $\Omega$ , Typical)
45 ( $V_{CC} > 3.6V$ only)	1.18
40 ( $V_{CC} > 3.6V$ only)	1.32
35	1.51
30	1.76
25	2.12
20	2.65
15	3.53
10	5.29
5	10.6
2	26.5

### 7.3.2 Constant-current Driver On or Off Control

When BLANK is low, the corresponding output is turned on if the data in the on or off control data latch are '1' and remains off if the data are '0'. When BLANK is high, all outputs are forced off. This control is shown in [Table 7-2](#).

**Table 7-2. Output On or Off Control Data Truth Table**

OUTPUT ON OR OFF DATA	CONSTANT-CURRENT OUTPUT STATUS
0	Off
1	On

When the device is initially powered on, the data in the 16-bit shift register and output on or off data latch are not set to default values. Therefore, the output on or off data must be written to the data latch before turning the constant-current output on. **BLANK should be high when powered on because the constant-current may be turned on as a result of random data in the output on or off data latch.**

### 7.3.3 Noise Reduction

Large surge currents can flow through the device and board if all 16 outputs turn on or off simultaneously. These large current surges can induce detrimental noise and electromagnetic interference (EMI) into other circuits. The TLC59283 independently turns on or off the outputs for each group with a 1ns (typ) delay time; see Figure 5-3. The 16 outputs are grouped into nine groups of either one or two outputs: group 1 (OUT0), group 2 (OUT1 and OUT15), group 3 (OUT2 and OUT14), group 4 (OUT3 and OUT13), group 5 (OUT4 and OUT12), group 6 (OUT5 and OUT11), group 7 (OUT6 and OUT10), group 8 (OUT7 and OUT9), and group 9 (OUT9). Both turn-on and turn-off times are delayed when BLANK transitions from low to high or high to low. Also when output-on and -off data are changed at the LAT rising edge while BLANK is low, both turn-on and turn-off times are delayed. However, the state of each output is controlled by the data in the output on or off data latch and the BLANK level.

#### 7.3.3.1 Internal Pre-Charge FET

The internal pre-charge FET prevents ghosting of multiplexed LED modules. One cause of this phenomenon is the parasitic capacitance charging current of the constant-current outputs (OUT<sub>n</sub>) and PCB wiring connected to OUT<sub>n</sub> through the LED. One of the mechanisms is shown in Figure 7-1.

In Figure 7-1, the constant-current driver turns LED0-0 on at (1) and off at (2). After LED0-0 is turned off, the OUT0 voltage is pulled up to V<sub>CHG</sub> by LED0-0. This OUT0 node has some parasitic capacitance (such as the constant-current driver output capacitance and the board layout capacitance shown as C0-2). After LED0-0 turns off, SWPMOS0 is turned off, SWNMOS0 is turned on for COM0, and COM0 is pulled down to GND. Because there is a parasitic capacitance between COM0 and OUT0, the OUT0 voltage is also pulled down to GND. Afterwards, SWPMOS1 is turned on for the next common line (COM1). When SWPMOS1 turns on, the OUT0 voltage is pulled up from the ground voltage to V<sub>LED</sub> - V<sub>F</sub>. The charge current (I<sub>CHRG</sub>) flows to the parasitic capacitor (C0) through LED1-0, causing the LED to briefly turn on and creating a ghosting effect of LED1-0.

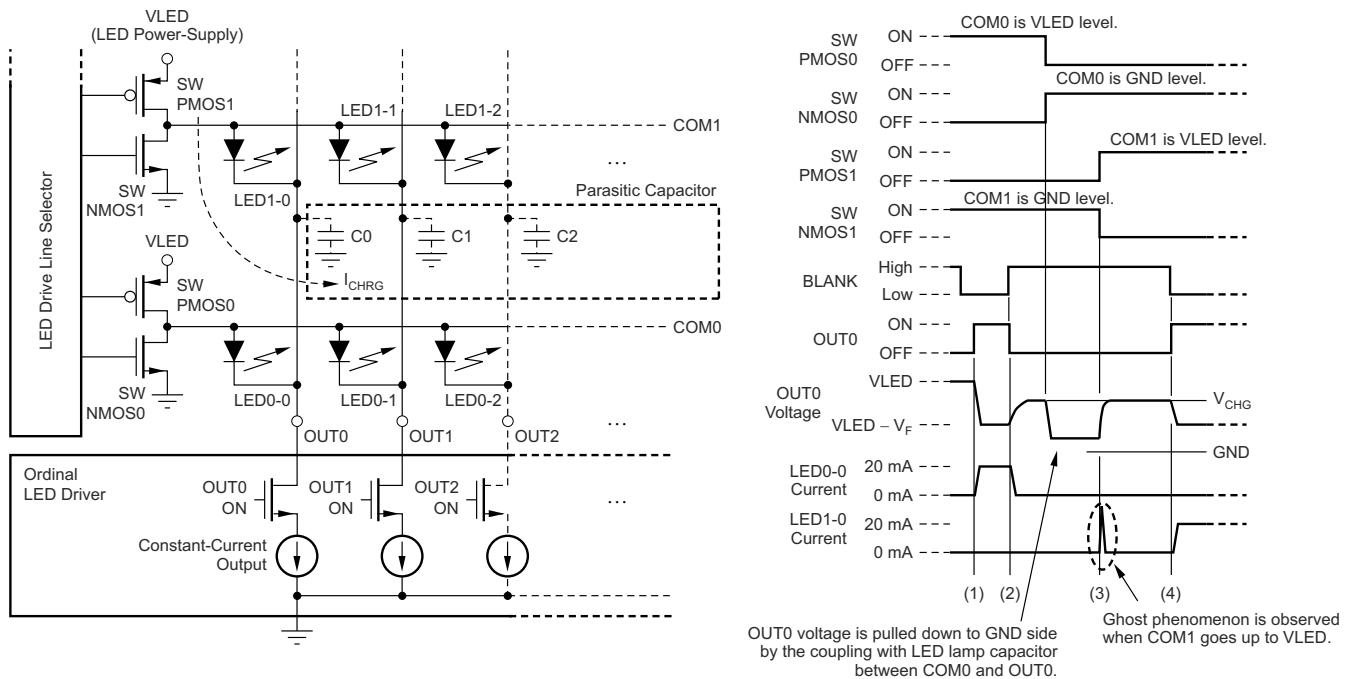

Figure 7-1. LED Ghost-Lighting Phenomenon Mechanism

The TLC59283 has an internal pre-charge FET to prevent ghosting, as shown in Figure 7-2. When a small delay after PWM control for a single common line completes, the FET pulls  $OUT_n$  up to  $V_{CC}$ . The charge current does not flow to  $C_0$  through LED1-0 when SWMOS1 is turned on and the ghosting is eliminated at (3). However, depending on the LED anode voltage, the number of LEDs in series, the LED forward voltage, and the TLC59283  $V_{CC}$  supply voltage, there may not be a great enough ghost-canceling effect.

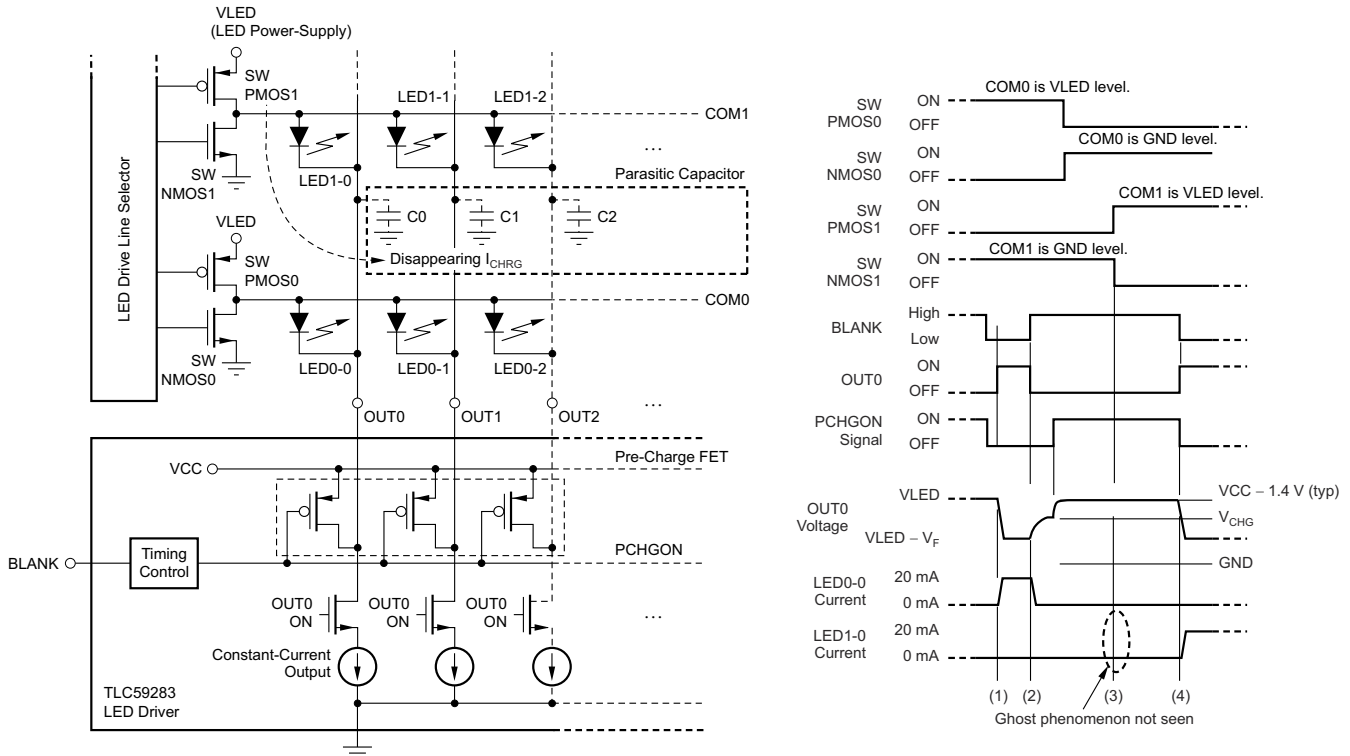

Figure 7-2. LED Ghost-lighting Mechanism by Pre-charge FET

### 7.3.3.2 Improve Output Control Loop Stability

Large parasitic inductances associated with the outputs of the TLC59283 have the potential of causing current loop instability that can manifest as spurious oscillations. Those parasitic inductances are most commonly associated with long traces or with the use of connectors between boards. The Application Note [Improve TLC59283 Control Loop Stability for Appliance Application \(SLVAFP4\)](#) describes how to minimize instability by compensating the feedback loop with small RC circuits.

## 8 Register Configuration

The TLC59283 has a 16-bit shift register and an output on or off data latch. Both the shift register and data latch are 16 bits long and are used to turn the constant-current outputs on and off. [Figure 8-1](#) shows the shift register and data latch configuration. The data at the SIN pin are shifted into the 16-bit shift register LSB at the rising edge of the SCLK pin; SOUT data change at the SCLK rising edge.

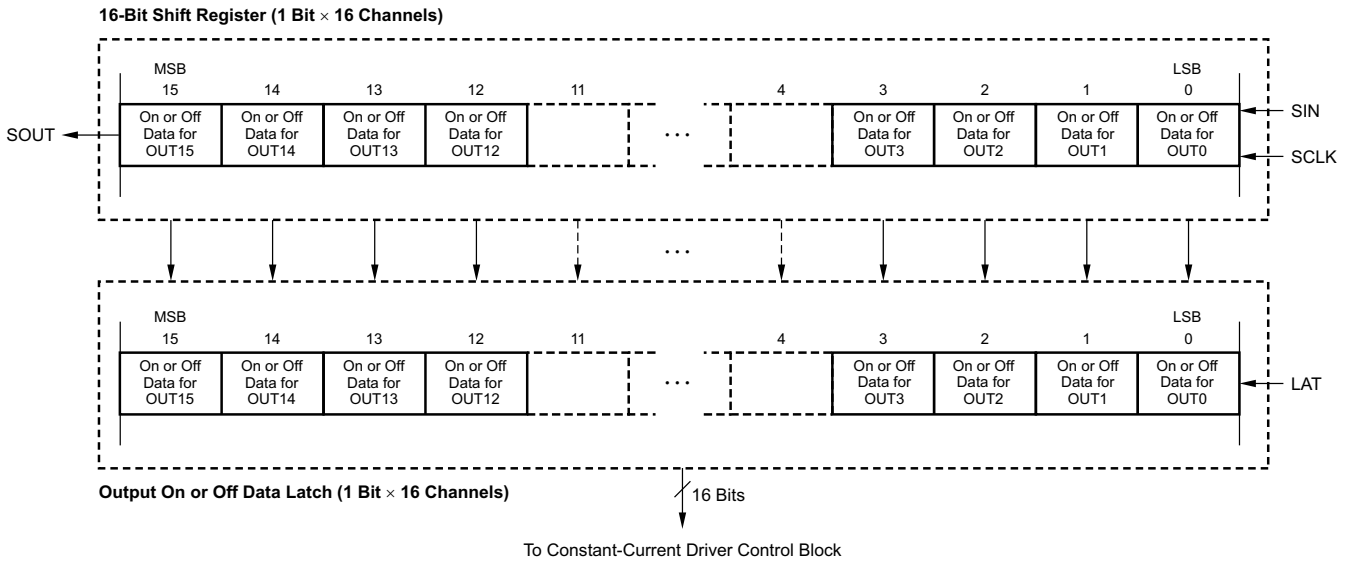

**Figure 8-1. 16-Bit Shift Register and Output On or Off Data Latch Configuration**

The output on or off data in the 16-bit shift register continue to transfer to the output on or off data latch while LAT is high. Therefore, if the data in the 16-bit shift register are changed when LAT is high, the data in the data latch are also changed. The data in the data latch are held when LAT is low. When the device initially powers on, the data in the output on or off shift register and latch are not set to default values; on or off control data must be written to the on or off control data latch before turning the constant-current output on. All constant-current outputs are forced off when BLANK is high. The  $OUT_n$  on or off outputs are controlled by the data in the output on or off data latch. The writing data truth table and timing diagram are shown in [Table 8-1](#) and [Figure 8-2](#), respectively.

**Table 8-1. Truth Table in Operation**

SCLK	LAT	BLANK	SIN	OUT0...OUT7...OUT15	SOUT
↑	High	Low	$D_n$	$D_n \dots D_n - 7 \dots D_n - 15$	$D_n - 15$
↑	Low	Low	$D_n + 1$	No change	$D_n - 14$
↑	High	Low	$D_n + 2$	$D_n + 2 \dots D_n - 5 \dots D_n - 13$	$D_n - 13$
↓	—	Low	$D_n + 3$	$D_n + 2 \dots D_n - 5 \dots D_n - 13$	$D_n - 13$
↓	—	High	$D_n + 3$	Off	$D_n - 13$

**TLC59283**

SBVS199C – JUNE 2012 – REVISED JANUARY 2024

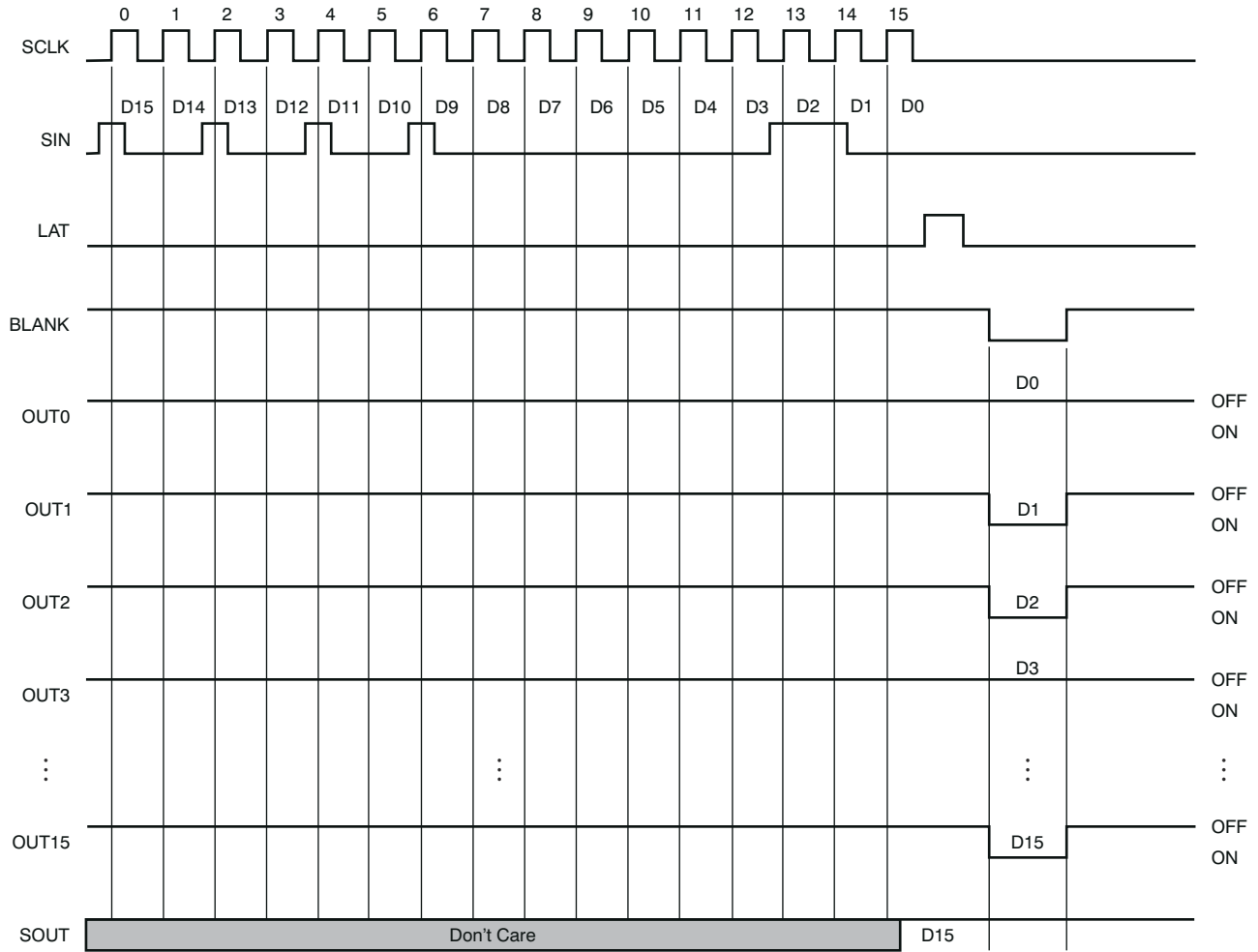

**Figure 8-2. Operation Timing Diagram**

## 9 Application and Implementation

### Note

Information in the following applications sections is not part of the TI component specification, and TI does not warrant its accuracy or completeness. TI's customers are responsible for determining suitability of components for their purposes, as well as validating and testing their design implementation to confirm system functionality.

### 9.1 Application Information

With the blossoming of AI (Artificial Intelligence) and IoT (Internet of Things), more and more end equipments use larger quantities of LEDs to show different statuses or functions. From the HMI (Human Machine Interface) perspective, LED indication, including LED-based seven-segment, dot-matrix displays, and a large quantity of LED indicators are bringing new dimensions of versatility and eye-pleasing visual effects to a growing number of applications. This application report showcases how to use the TLC59283 to drive seven-segment, dot-matrix displays or a large quantity of LEDs with the advantages of better brightness uniformity, smaller size, and ghosting elimination over current solutions. For additional details see [Use TLC59283 for LED Indication with Better Brightness Uniformity, Smaller Size, and Ghosting Elimination](#)

### 9.2 Typical Application

[Typical Application Circuit \(Multiple Daisy-Chained TLC59283s\)](#) shows the typical application schematic for the TLC59283.

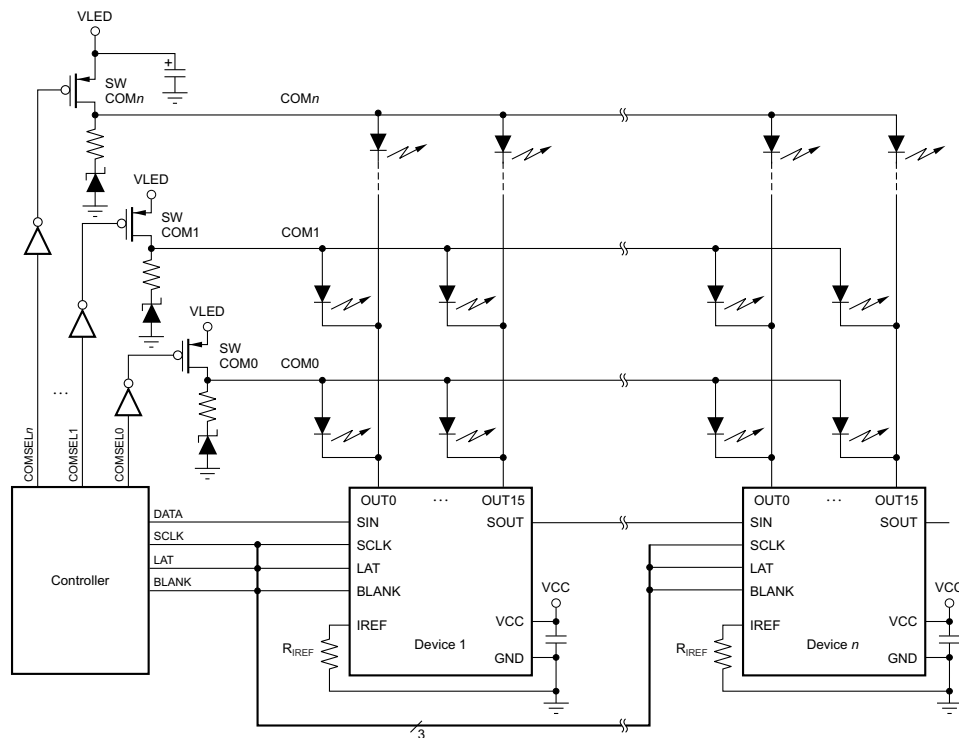

**Typical Application Circuit (Multiple Daisy-Chained TLC59283s)**

### 9.2.1 Design Requirements

**Table 9-1. Design Parameters**

PARAMETER	VALUE
Supply Voltage	3~5.5V
Output Voltage	<10V
Output Current	<45mA
Dimming Option	No dimming option

### 9.2.2 Detailed Design Procedure

This section show how to use the TLC59283 to drive the LED matrix using time-multiplexing topology. To form a time-multiplexing topology, it is necessary to add external switching MOSFETs or transistors. If there is enough I/Os in the system to control the transistors, a block diagram like [Figure 8-1](#) can be used to drive 64 LEDs.

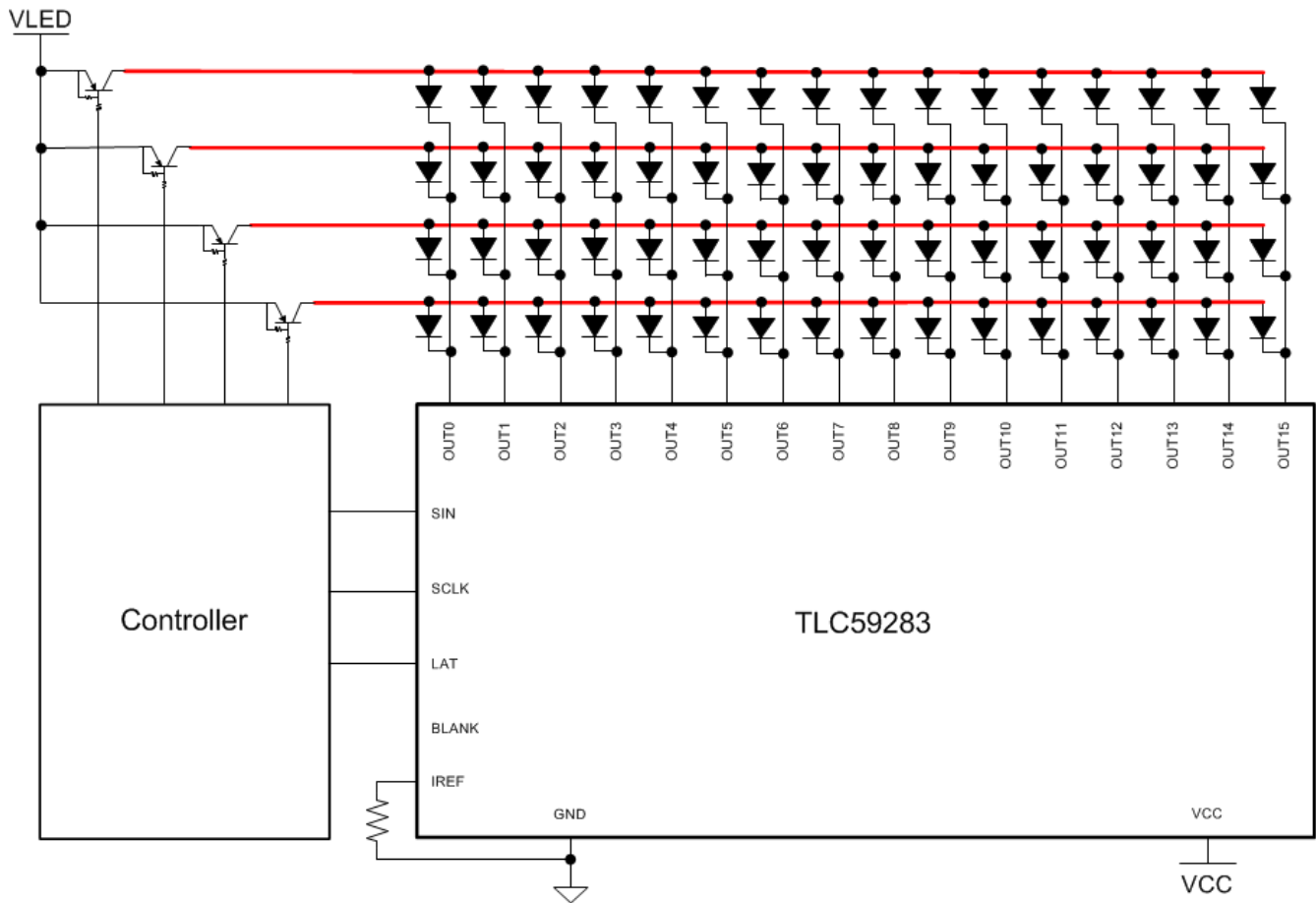

**Figure 9-1. Time-multiplexing Circuit Using TLC59283 and Enough I/Os**

If there are not enough I/Os in the system to control the transistors, a block diagram like [Figure 8-2](#) can be used to drive 64 LEDs.

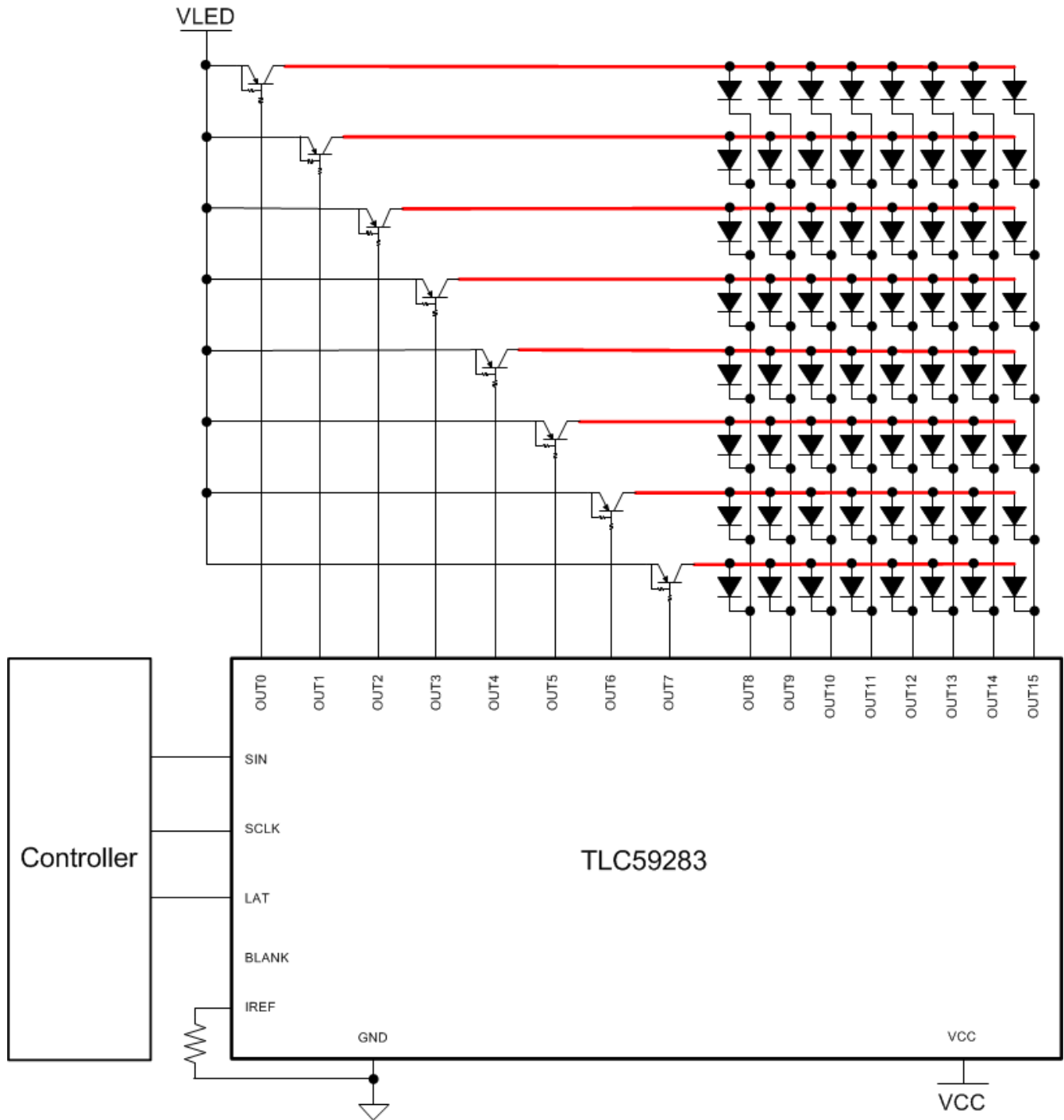

**Figure 9-2. Time-multiplexing Circuit Using TLC59283 and Less I/Os**

### 9.2.3 Application Performance Plots

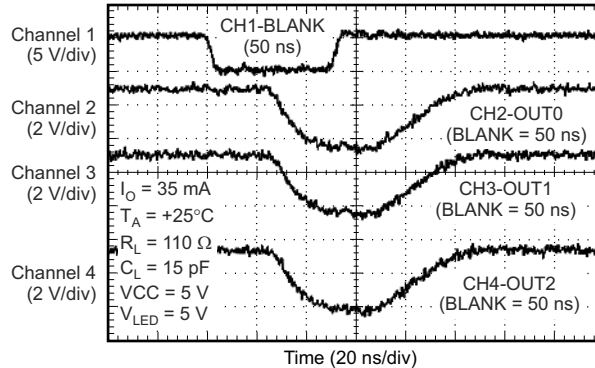

G021

**Figure 9-3. Constant-current Output Voltage Waveform**

## 9.3 Power Supply Recommendations

The device is designed to operate from an input voltage supply range from 3V to 5.5V. This input supply must be well regulated. If the input supply is located more than a few inches from the converter, additional bulk capacitance is required near to the ceramic bypass capacitors. A typical choice is a tantalum or aluminum electrolytic capacitor with a value of 1 $\mu$ F.

## 9.4 Layout

### 9.4.1 Layout Guidelines

The input capacitor needs not only to be close to the VIN pin, but also to the GND pin in order to reduce input supply ripple. For OUTx, path outputs must be short and wide and avoid parallel wiring and narrow trace. For better thermal performance, TI suggest to make copper polygon connected with each pin bigger.

### 9.4.2 Layout Example

One TLC59283 can drive up to 16 LEDs directly, so it can replace two 74HC595 and the current limit resistors if driving two seven segment displays. The below figure makes a simple comparison and the PCB size is 65% smaller using the TLC59283. If you are using the QFN package, the size is even smaller.

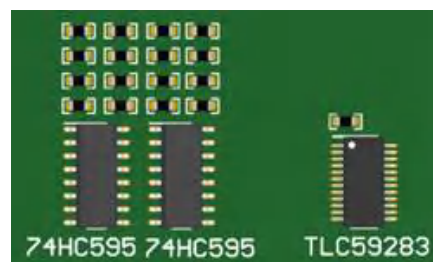

**Figure 9-4. TLC59283 Layout Example**

## 10 Device and Documentation Support

TI offers an extensive line of development tools. Tools and software to evaluate the performance of the device, generate code, and develop solutions are listed below.

### 10.1 Third-Party Products Disclaimer

TI'S PUBLICATION OF INFORMATION REGARDING THIRD-PARTY PRODUCTS OR SERVICES DOES NOT CONSTITUTE AN ENDORSEMENT REGARDING THE SUITABILITY OF SUCH PRODUCTS OR SERVICES OR A WARRANTY, REPRESENTATION OR ENDORSEMENT OF SUCH PRODUCTS OR SERVICES, EITHER ALONE OR IN COMBINATION WITH ANY TI PRODUCT OR SERVICE.

### 10.2 Documentation Support

#### 10.2.1 Related Documentation

- [TLC59282 Evaluation Module](#)
- [Use TLC59283 for LED Indication with Better Brightness Uniformity, Smaller Size, and Ghosting Elimination](#)
- [Improve TLC59283 Control Loop Stability for Appliance Application](#)

### 10.3 Receiving Notification of Documentation Updates

To receive notification of documentation updates, navigate to the device product folder on [ti.com](#). Click on *Notifications* to register and receive a weekly digest of any product information that has changed. For change details, review the revision history included in any revised document.

### 10.4 Support Resources

[TI E2E™ support forums](#) are an engineer's go-to source for fast, verified answers and design help — straight from the experts. Search existing answers or ask your own question to get the quick design help you need.

Linked content is provided "AS IS" by the respective contributors. They do not constitute TI specifications and do not necessarily reflect TI's views; see TI's [Terms of Use](#).

### 10.5 Trademarks

TI E2E™ is a trademark of Texas Instruments.  
All trademarks are the property of their respective owners.

### 10.6 Electrostatic Discharge Caution



This integrated circuit can be damaged by ESD. Texas Instruments recommends that all integrated circuits be handled with appropriate precautions. Failure to observe proper handling and installation procedures can cause damage.

ESD damage can range from subtle performance degradation to complete device failure. Precision integrated circuits may be more susceptible to damage because very small parametric changes could cause the device not to meet its published specifications.

### 10.7 Glossary

[TI Glossary](#) This glossary lists and explains terms, acronyms, and definitions.

## 11 Revision History

NOTE: Page numbers for previous revisions may differ from page numbers in the current version.

<b>Changes from Revision B (October 2012) to Revision C (January 2024)</b>	<b>Page</b>
• Updated the numbering format for tables, figures, and cross-references throughout the document.....	1
• Added Improve TLC59283 Control Loop Stability for Appliance Application (SLVAFP4) .pdf link.....	18

---

<b>Changes from Revision A (June 2012) to Revision B (October 2012)</b>	<b>Page</b>
• Changed HBM ESD rating maximum specification in the Absolute Maximum Ratings table.....	5
• Changed I <sub>CC2</sub> typical and maximum specifications in Electrical Characteristics table.....	7
• Changed I <sub>CC3</sub> typical specification in Electrical Characteristics table.....	7

---

## 12 Mechanical, Packaging, and Orderable Information

The following pages include mechanical, packaging, and orderable information. This information is the most current data available for the designated devices. This data is subject to change without notice and revision of this document. For browser-based versions of this data sheet, refer to the left-hand navigation.

**PACKAGING INFORMATION**

Orderable Device	Status (1)	Package Type	Package Drawing	Pins	Package Qty	Eco Plan (2)	Lead finish/ Ball material (6)	MSL Peak Temp (3)	Op Temp (°C)	Device Marking (4/5)	Samples
TLC59283DBQ	ACTIVE	SSOP	DBQ	24	50	RoHS & Green	NIPDAU	Level-2-260C-1 YEAR	-40 to 85	TLC59283	<a href="#">Samples</a>
TLC59283DBQR	ACTIVE	SSOP	DBQ	24	2500	RoHS & Green	NIPDAU	Level-2-260C-1 YEAR	-40 to 85	TLC59283	<a href="#">Samples</a>
TLC59283RGER	ACTIVE	VQFN	RGE	24	3000	RoHS & Green	NIPDAU	Level-2-260C-1 YEAR	-40 to 85	TLC 59283	<a href="#">Samples</a>
TLC59283RGET	ACTIVE	VQFN	RGE	24	250	RoHS & Green	NIPDAU	Level-2-260C-1 YEAR	-40 to 85	TLC 59283	<a href="#">Samples</a>

(1) The marketing status values are defined as follows:

**ACTIVE:** Product device recommended for new designs.

**LIFEBUY:** TI has announced that the device will be discontinued, and a lifetime-buy period is in effect.

**NRND:** Not recommended for new designs. Device is in production to support existing customers, but TI does not recommend using this part in a new design.

**PREVIEW:** Device has been announced but is not in production. Samples may or may not be available.

**OBSELETE:** TI has discontinued the production of the device.

(2) **RoHS:** TI defines "RoHS" to mean semiconductor products that are compliant with the current EU RoHS requirements for all 10 RoHS substances, including the requirement that RoHS substance do not exceed 0.1% by weight in homogeneous materials. Where designed to be soldered at high temperatures, "RoHS" products are suitable for use in specified lead-free processes. TI may reference these types of products as "Pb-Free".

**RoHS Exempt:** TI defines "RoHS Exempt" to mean products that contain lead but are compliant with EU RoHS pursuant to a specific EU RoHS exemption.

**Green:** TI defines "Green" to mean the content of Chlorine (Cl) and Bromine (Br) based flame retardants meet JS709B low halogen requirements of <=1000ppm threshold. Antimony trioxide based flame retardants must also meet the <=1000ppm threshold requirement.

(3) MSL, Peak Temp. - The Moisture Sensitivity Level rating according to the JEDEC industry standard classifications, and peak solder temperature.

(4) There may be additional marking, which relates to the logo, the lot trace code information, or the environmental category on the device.

(5) Multiple Device Markings will be inside parentheses. Only one Device Marking contained in parentheses and separated by a "~" will appear on a device. If a line is indented then it is a continuation of the previous line and the two combined represent the entire Device Marking for that device.

(6) Lead finish/Ball material - Orderable Devices may have multiple material finish options. Finish options are separated by a vertical ruled line. Lead finish/Ball material values may wrap to two lines if the finish value exceeds the maximum column width.

**Important Information and Disclaimer:**The information provided on this page represents TI's knowledge and belief as of the date that it is provided. TI bases its knowledge and belief on information provided by third parties, and makes no representation or warranty as to the accuracy of such information. Efforts are underway to better integrate information from third parties. TI has taken and

continues to take reasonable steps to provide representative and accurate information but may not have conducted destructive testing or chemical analysis on incoming materials and chemicals. TI and TI suppliers consider certain information to be proprietary, and thus CAS numbers and other limited information may not be available for release.

In no event shall TI's liability arising out of such information exceed the total purchase price of the TI part(s) at issue in this document sold by TI to Customer on an annual basis.

**TAPE AND REEL INFORMATION**

**QUADRANT ASSIGNMENTS FOR PIN 1 ORIENTATION IN TAPE**



\*All dimensions are nominal

Device	Package Type	Package Drawing	Pins	SPQ	Reel Diameter (mm)	Reel Width W1 (mm)	A0 (mm)	B0 (mm)	K0 (mm)	P1 (mm)	W (mm)	Pin1 Quadrant
TLC59283DBQR	SSOP	DBQ	24	2500	330.0	16.4	6.5	9.0	2.1	8.0	16.0	Q1
TLC59283RGER	VQFN	RGE	24	3000	330.0	12.4	4.25	4.25	1.15	8.0	12.0	Q2
TLC59283RGET	VQFN	RGE	24	250	180.0	12.4	4.25	4.25	1.15	8.0	12.0	Q2

**TAPE AND REEL BOX DIMENSIONS**

\*All dimensions are nominal

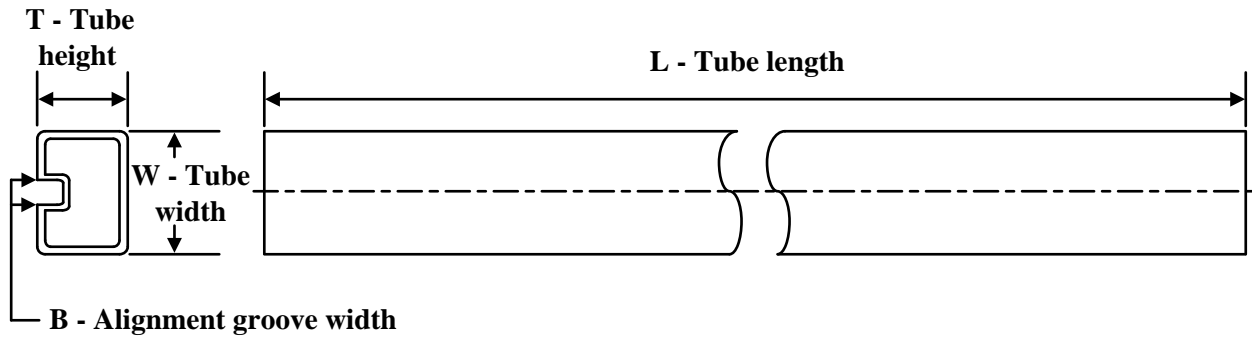
Device	Package Type	Package Drawing	Pins	SPQ	Length (mm)	Width (mm)	Height (mm)
TLC59283DBQR	SSOP	DBQ	24	2500	356.0	356.0	35.0
TLC59283RGER	VQFN	RGE	24	3000	346.0	346.0	33.0
TLC59283RGET	VQFN	RGE	24	250	210.0	185.0	35.0

**TUBE**

\*All dimensions are nominal

Device	Package Name	Package Type	Pins	SPQ	L (mm)	W (mm)	T (μm)	B (mm)
TLC59283DBQ	DBQ	SSOP	24	50	506.6	8	3940	4.32

## GENERIC PACKAGE VIEW

RGE 24

VQFN - 1 mm max height

PLASTIC QUAD FLATPACK - NO LEAD



Images above are just a representation of the package family, actual package may vary.  
Refer to the product data sheet for package details.

4204104/H



## IMPORTANT NOTICE AND DISCLAIMER

TI PROVIDES TECHNICAL AND RELIABILITY DATA (INCLUDING DATA SHEETS), DESIGN RESOURCES (INCLUDING REFERENCE DESIGNS), APPLICATION OR OTHER DESIGN ADVICE, WEB TOOLS, SAFETY INFORMATION, AND OTHER RESOURCES "AS IS" AND WITH ALL FAULTS, AND DISCLAIMS ALL WARRANTIES, EXPRESS AND IMPLIED, INCLUDING WITHOUT LIMITATION ANY IMPLIED WARRANTIES OF MERCHANTABILITY, FITNESS FOR A PARTICULAR PURPOSE OR NON-INFRINGEMENT OF THIRD PARTY INTELLECTUAL PROPERTY RIGHTS.

These resources are intended for skilled developers designing with TI products. You are solely responsible for (1) selecting the appropriate TI products for your application, (2) designing, validating and testing your application, and (3) ensuring your application meets applicable standards, and any other safety, security, regulatory or other requirements.

These resources are subject to change without notice. TI grants you permission to use these resources only for development of an application that uses the TI products described in the resource. Other reproduction and display of these resources is prohibited. No license is granted to any other TI intellectual property right or to any third party intellectual property right. TI disclaims responsibility for, and you will fully indemnify TI and its representatives against, any claims, damages, costs, losses, and liabilities arising out of your use of these resources.

TI's products are provided subject to [TI's Terms of Sale](#) or other applicable terms available either on [ti.com](https://www.ti.com) or provided in conjunction with such TI products. TI's provision of these resources does not expand or otherwise alter TI's applicable warranties or warranty disclaimers for TI products.

TI objects to and rejects any additional or different terms you may have proposed.

Mailing Address: Texas Instruments, Post Office Box 655303, Dallas, Texas 75265  
Copyright © 2024, Texas Instruments Incorporated

## Looking for pricing, stock, or lifecycle information?

Click below to explore more details on WIN SOURCE:

 [View TLC59283RGET on WIN SOURCE](#)

 [Texas Instruments](#) Information

## Optimize Your Supply Chain with WIN SOURCE Solutions

-  Global Sourcing Solution
-  Obsolete Management
-  Cost Control Management
-  Shortage Management
-  Alternative Solution
-  Excess Inventory Management