

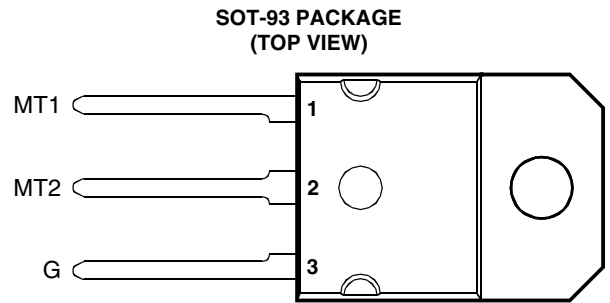

# THE DATASHEET OF TIC263M-S



- High Current Triacs
- 25 A RMS
- Glass Passivated Wafer
- 400 V to 800 V Off-State Voltage
- 175 A Peak Current
- Max  $I_{GT}$  of 50 mA (Quadrants 1 - 3)



Pin 2 is in electrical contact with the mounting base.

MDC2ADA

**absolute maximum ratings over operating case temperature (unless otherwise noted)**

RATING		SYMBOL	VALUE	UNIT
Repetitive peak off-state voltage (see Note 1)	TIC263D	$V_{DRM}$	400	V
	TIC263M		600	
	TIC263S		700	
	TIC263N		800	
Full-cycle RMS on-state current at (or below) 60°C case temperature (see Note 2)		$I_{T(RMS)}$	25	A
Peak on-state surge current full-sine-wave at (or below) 25°C case temperature (see Note 3)		$I_{TSM}$	175	A
Peak gate current		$I_{GM}$	±1	A
Operating case temperature range		$T_C$	-40 to +110	°C
Storage temperature range		$T_{stg}$	-40 to +125	°C
Lead temperature 1.6 mm from case for 10 seconds		$T_L$	230	°C

- NOTES: 1. These values apply bidirectionally for any value of resistance between the gate and Main Terminal 1.  
 2. This value applies for 50-Hz full-sine-wave operation with resistive load. Above 60°C derate linearly to 110°C case temperature at the rate of 500mA/°C.  
 3. This value applies for one 50-Hz full-sine-wave when the device is operating at (or below) the rated value of peak reverse voltage and on-state current. Surge may be repeated after the device has returned to original thermal equilibrium.

**electrical characteristics at 25°C case temperature (unless otherwise noted)**

PARAMETER		TEST CONDITIONS			MIN	TYP	MAX	UNIT
$I_{DRM}$	Repetitive peak off-state current	$V_D = \text{Rated } V_{DRM}$	$I_G = 0$	$T_C = 110^\circ\text{C}$			±2	mA
$I_{GT}$	Gate trigger current	$V_{supply} = +12\text{ V}†$	$R_L = 10\ \Omega$	$t_{p(g)} > 20\ \mu\text{s}$		15	50	mA
		$V_{supply} = +12\text{ V}†$	$R_L = 10\ \Omega$	$t_{p(g)} > 20\ \mu\text{s}$		-30	-50	
		$V_{supply} = -12\text{ V}†$	$R_L = 10\ \Omega$	$t_{p(g)} > 20\ \mu\text{s}$		-20	-50	
		$V_{supply} = -12\text{ V}†$	$R_L = 10\ \Omega$	$t_{p(g)} > 20\ \mu\text{s}$		32		
$V_{GT}$	Gate trigger voltage	$V_{supply} = +12\text{ V}†$	$R_L = 10\ \Omega$	$t_{p(g)} > 20\ \mu\text{s}$		0.8	2	V
		$V_{supply} = +12\text{ V}†$	$R_L = 10\ \Omega$	$t_{p(g)} > 20\ \mu\text{s}$		-0.8	-2	
		$V_{supply} = -12\text{ V}†$	$R_L = 10\ \Omega$	$t_{p(g)} > 20\ \mu\text{s}$		-0.8	-2	
		$V_{supply} = -12\text{ V}†$	$R_L = 10\ \Omega$	$t_{p(g)} > 20\ \mu\text{s}$		0.8	2	
$V_T$	On-state voltage	$I_T = \pm 35.2\text{ A}$	$I_G = 50\text{ mA}$	(see Note 4)		±1.5	±1.7	V

† All voltages are with respect to Main Terminal 1.

NOTE 4: This parameter must be measured using pulse techniques,  $t_p \leq 1\text{ ms}$ , duty cycle  $\leq 2\%$ . Voltage-sensing contacts separate from the current carrying contacts are located within 3.2 mm from the device body.

**PRODUCT INFORMATION**

DECEMBER 1971 - REVISED SEPTEMBER 2002  
 Specifications are subject to change without notice.

electrical characteristics at 25°C case temperature (unless otherwise noted) (continued)

PARAMETER	TEST CONDITIONS			MIN	TYP	MAX	UNIT
$I_H$ Holding current	$V_{supply} = +12 V \dagger$ $V_{supply} = -12 V \dagger$	$I_G = 0$ $I_G = 0$	Init' $I_T = 100 \text{ mA}$ Init' $I_T = -100 \text{ mA}$		20 -10	40 -40	mA
$I_L$ Latching current	$V_{supply} = +12 V \dagger$ $V_{supply} = -12 V \dagger$	(see Note 5)			20 -20		mA
dv/dt Critical rate of rise of off-state voltage	$V_D = \text{Rated } V_D$	$I_G = 0$	$T_C = 110^\circ\text{C}$		$\pm 450$		V/ $\mu\text{s}$
dv/dt <sub>(c)</sub> Critical rise of commutation voltage	$V_D = \text{Rated } V_D$ di/dt = 0.5 $I_{T(RMS)}/\text{ms}$		$T_C = 80^\circ\text{C}$ $I_T = 1.4 I_{T(RMS)}$		$\pm 1$		V/ $\mu\text{s}$
di/dt Critical rate of rise of on-state current	$V_D = \text{Rated } V_D$ di <sub>G</sub> /dt = 50 mA/ $\mu\text{s}$	$I_{GT} = 50 \text{ mA}$	$T_C = 110^\circ\text{C}$		$\pm 100$		A/ $\mu\text{s}$

† All voltages are with respect to Main Terminal 1.

NOTE 5: The triacs are triggered by a 15-V (open-circuit amplitude) pulse supplied by a generator with the following characteristics:  
 $R_G = 100 \Omega$ ,  $t_{p(g)} = 20 \mu\text{s}$ ,  $t_r \leq 15 \text{ ns}$ ,  $f = 1 \text{ kHz}$ .

thermal characteristics

PARAMETER	MIN	TYP	MAX	UNIT
$R_{\theta JC}$ Junction to case thermal resistance			1.52	$^\circ\text{C}/\text{W}$
$R_{\theta JA}$ Junction to free air thermal resistance			36	$^\circ\text{C}/\text{W}$

TYPICAL CHARACTERISTICS

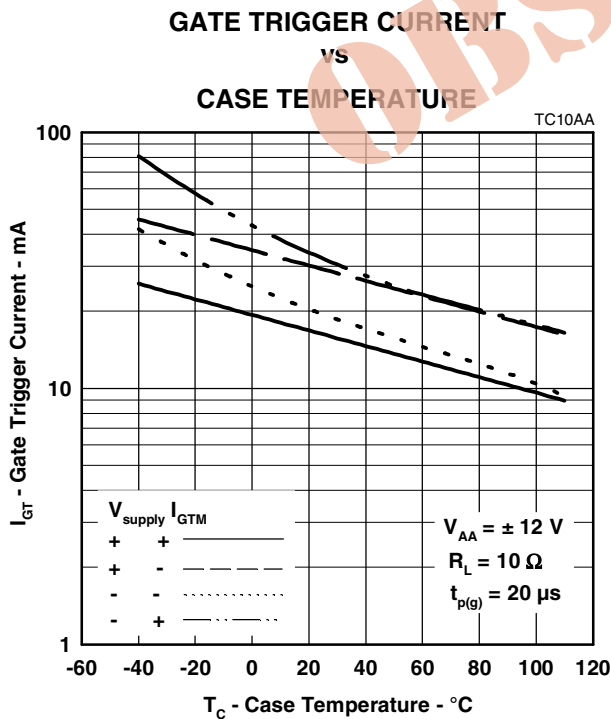

Figure 1.

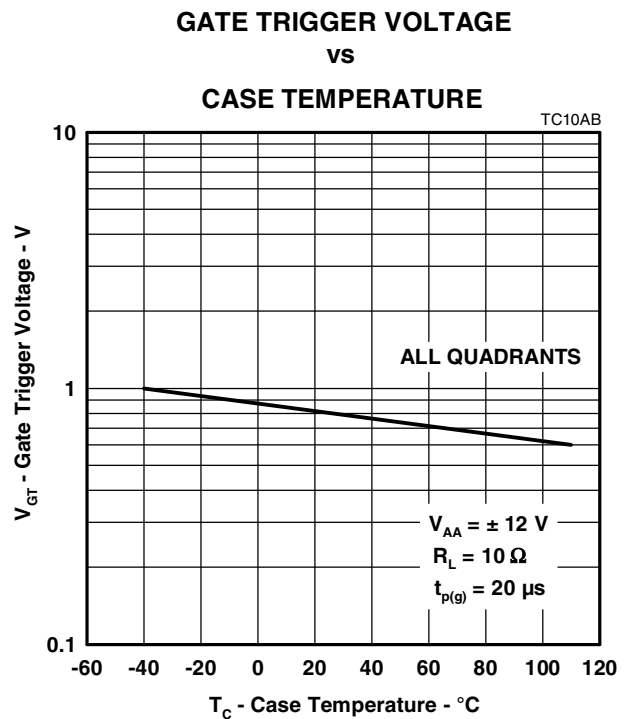
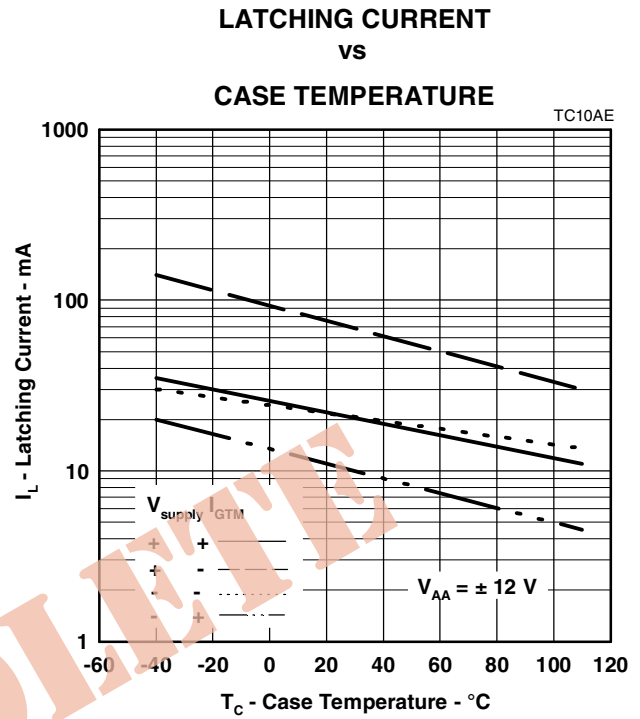
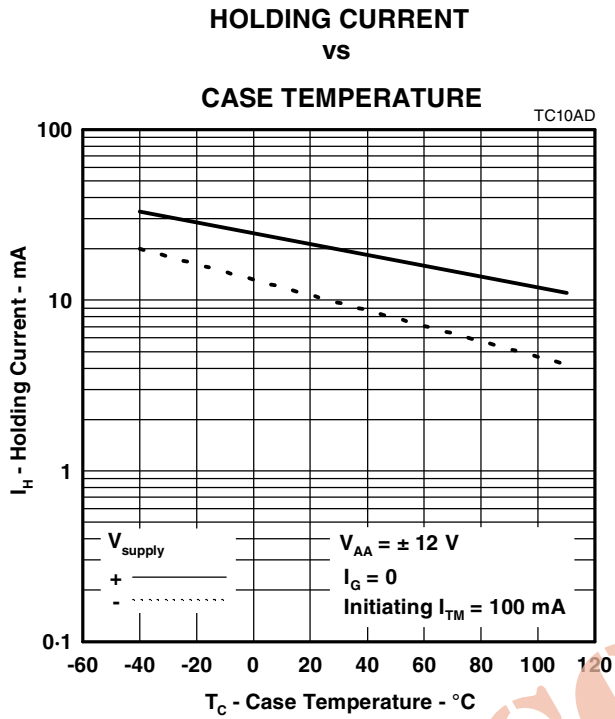

Figure 2.

**PRODUCT INFORMATION**

DECEMBER 1971 - REVISED SEPTEMBER 2002  
Specifications are subject to change without notice.

TYPICAL CHARACTERISTICS



**PRODUCT INFORMATION**

DECEMBER 1971 - REVISED SEPTEMBER 2002  
Specifications are subject to change without notice.

## Looking for pricing, stock, or lifecycle information?

Click below to explore more details on WIN SOURCE:

 [View TIC263M-S on WIN SOURCE](#)

 [Bourns Inc. Information](#)

## Optimize Your Supply Chain with WIN SOURCE Solutions

-  Global Sourcing Solution
-  Obsolete Management
-  Cost Control Management
-  Shortage Management
-  Alternative Solution
-  Excess Inventory Management