

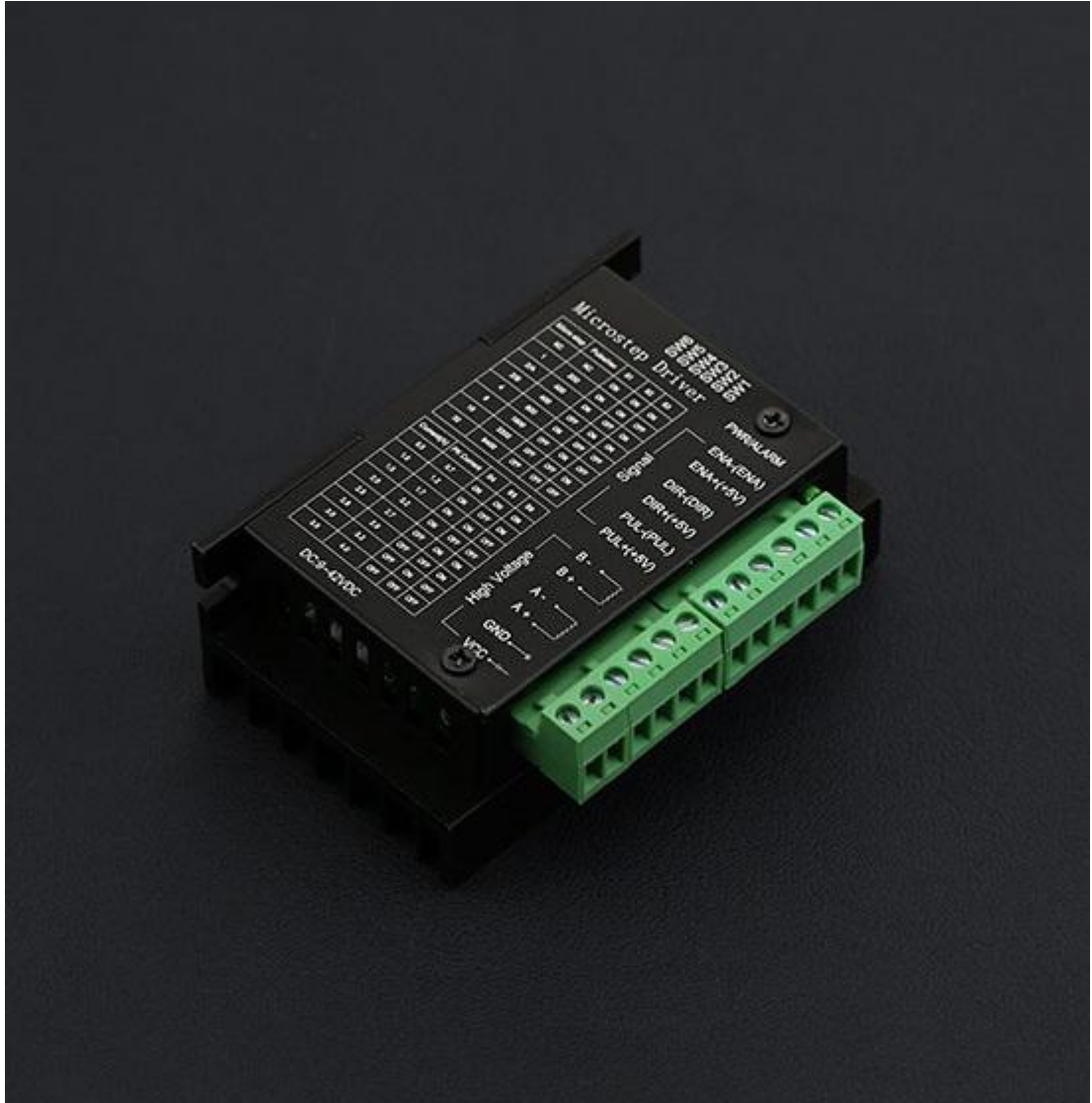

**THE DATASHEET OF  
DRI0043**



# TB6600 Stepper Motor Driver User Guide



Version: V1.2

# Contents

1. Introduction.....	1
Features:.....	1
Electric Specification:.....	1
INPUT & OUTPUT:.....	2
2. Stepper Motor Wiring:.....	4
3. Microcontroller Connection Diagram:.....	5
4. DIP Switch.....	6
Micro Step Setting.....	6
Current Control Setting.....	6
5. Off-line Function (EN Terminal):.....	7
6. FAQ.....	7
7. Dimension (96*56*33).....	8

Safety Precautions:

- Before using this product, please read this instruction manual carefully
- Keep this manual in a safe place for future reference
- The appearance of the picture is just for reference, please prevail in kind
- ❖ This device is driven by DC power supply, make sure the power positive and negative before you power it.
- ❖ Please do not electrified plug
- ❖ Please do not mix conductive foreign matter such as screws or metal
- ❖ Please keep it dry, and pay attention to moisture-proof
- ❖ The equipment should be clean and well ventilated.

# 1. Introduction

This is a professional two-phase stepper motor driver. It supports speed and direction control. You can set its micro step and output current with 6 DIP switch. There are 7 kinds of micro steps (1, 2 / A, 2 / B, 4, 8, 16, 32) and 8 kinds of current control (0.5A, 1A, 1.5A, 2A, 2.5A, 2.8A, 3.0A, 3.5A) in all. And all signal terminals adopt high-speed optocoupler isolation, enhancing its anti-high-frequency interference ability.

## Features:

- ※ Support 8 kinds of current control
- ※ Support 7 kinds of micro steps adjustable
- ※ The interfaces adopt high-speed optocoupler isolation
- ※ Automatic semi-flow to reduce heat
- ※ Large area heat sink
- ※ Anti-high-frequency interference ability
- ※ Input anti-reverse protection
- ※ Overheat, over current and short circuit protection

## Electrical Specification:

Input Current	0~5.0A
Output Current	0.5-4.0A
Power (MAX)	160W
Micro Step	1, 2/A, 2/B, 4, 8, 16, 32
Temperature	-10 ~ 45°C
Humidity	No Condensation
Weight	0.2 kg
Dimension	96*56*33 mm

## INPUT & OUTPUT:

- **Signal Input:**

PUL+	Pulse +
PUL-	Pulse -
DIR+	Direction +
DIR-	Direction -
EN+	Off-line Control Enable +
EN-	Off-line Control Enable -

- **Motor Machine Winding:**

A+	Stepper motor A+
A-	Stepper motor A-
B+	Stepper motor B+
B-	Stepper motor B-

- **Power Supply:**

VCC	VCC (DC9-42V)
GND	GND

- **Wiring instructions**

There are three input signals in all: ① Step pulse signal PUL +, PUL-; ② Direction signal DIR +, DIR-; ③ off-line signal EN +, EN-. The driver supports common-cathode and common-anode circuit, you can select one according to your demand.

**Common-Anode Connection:**

Connect PUL +, DIR + and EN + to the power supply of the control system. If the power supply is + 5V, it can be directly connected. If the power supply is more than + 5V, the current limiting resistor R must be added externally. To ensure that the controller pin can output 8 ~ 15mA current to drive the internal optocoupler chip. Pulse signal connects to PUL-; direction signal connects to Dir- ; Enable signal connects to EN-. As shown below:

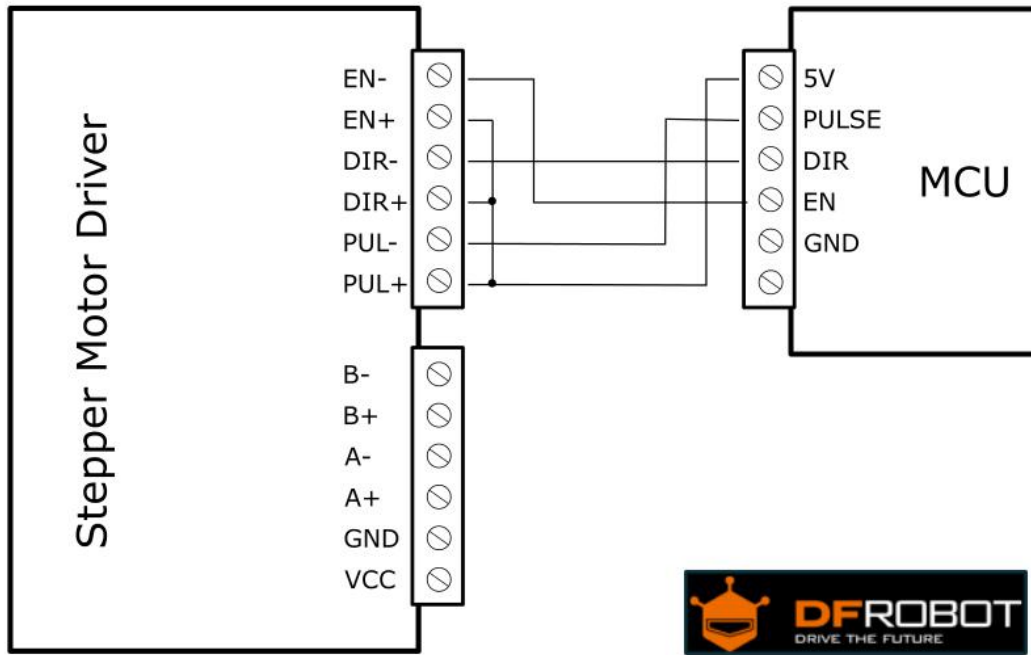

**Common-Cathode Connection:**

Connect PUL -, DIR - and EN - to the ground terminal of the control system. Pulse signal connects to PUL-; direction signal connects to Dir- ; Enable signal connects to EN-. As shown below:

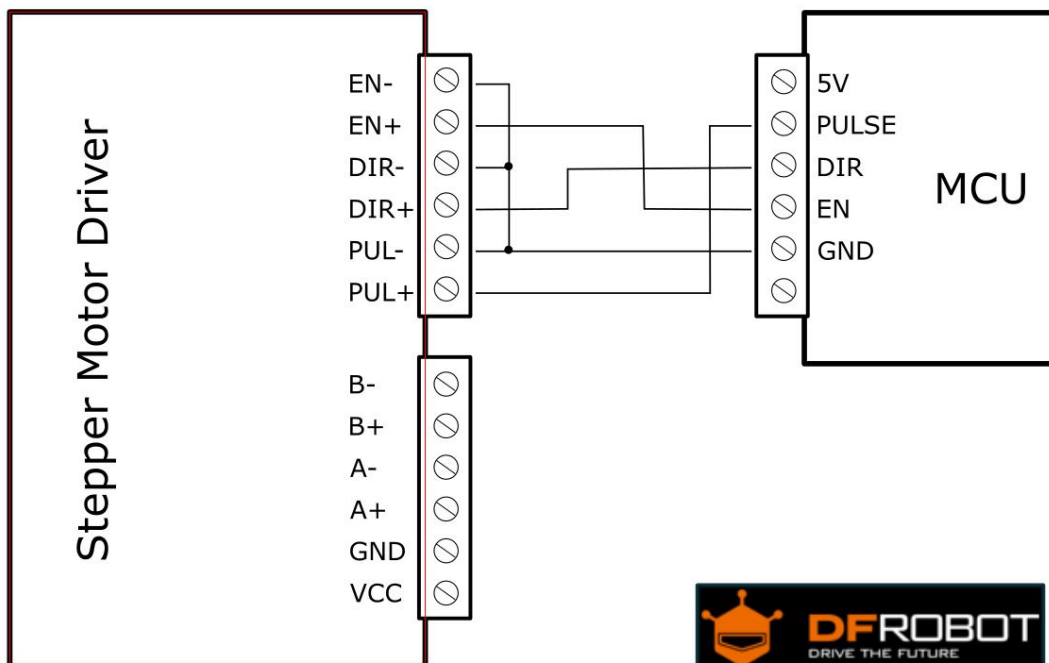

Note: When "EN" is in the valid state, the motor is in a free states (Off-line mode). In this mode, you can adjust the motor shaft position manually. When "EN" is in the invalid state, the motor will be in an automatic control mode.

## 2. Stepper Motor Wiring:

Two-phase 4-wire, 6-wire, 8-wire motor wiring, as shown below:

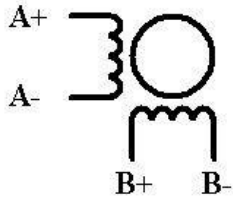

四线电机接线方法

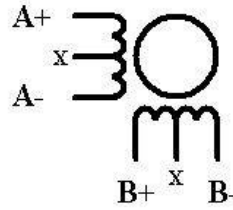

六线电机接线方法  
高力矩输出

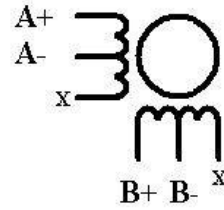

六线电机接线方法  
高速度输出

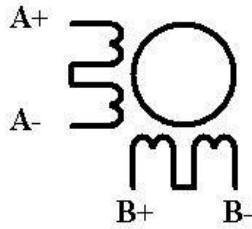

八线电机接线方法  
高力矩输出

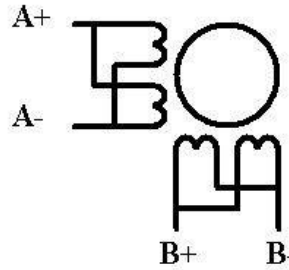

八线电机接线方法  
高速度输出

### 3. Microcontroller Connection Diagram:

This is an example for the common-anode connection. ( "EN" not connected )

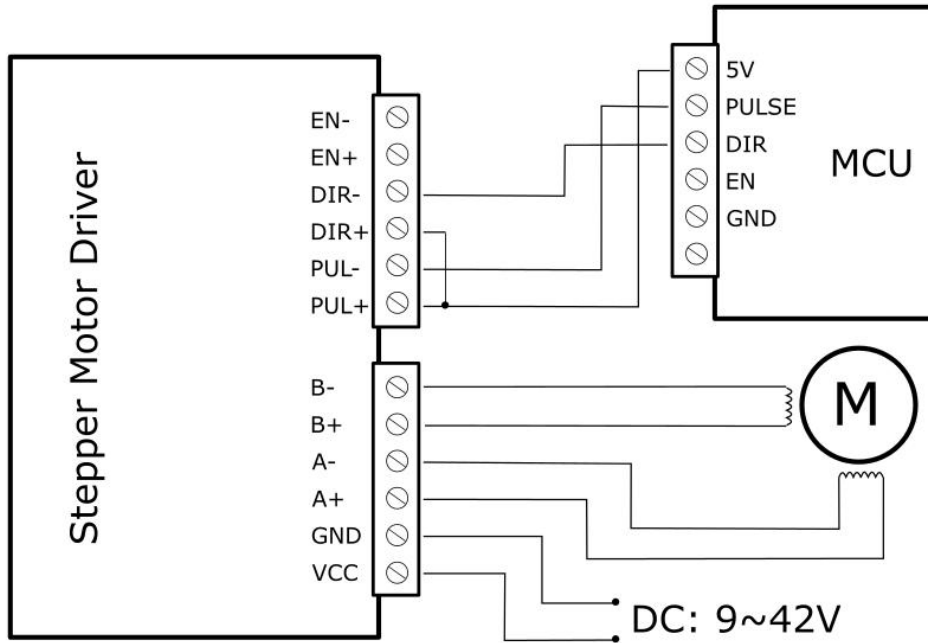

Note: Please cut off the power when you connect the system, and ensure the power polar is correct. Or it will damage the controller.

## 4. DIP Switch

### Micro Step Setting

The follow tablet shows the driver Micro step. You can set the motor micro step via the first three DIP switch.

$$\text{Step Angle} = \text{Motor Step Angle} / \text{Micro Step}$$

E.g. An stepper motor with 1.8° step angle , the finial step angle under “Micro step 4” will be  $1.8^\circ/4=0.45^\circ$

Micro Step	Pulse/Rev	S1	S2	S3
NC	NC	ON	ON	ON
1	200	ON	ON	OFF
2/A	400	ON	OFF	ON
2/B	400	OFF	ON	ON
4	800	ON	OFF	OFF
8	1600	OFF	ON	OFF
16	3200	OFF	OFF	ON
32	6400	OFF	OFF	OFF

### Current Control Setting

Current (A)	S4	S5	S6
0.5	ON	ON	ON
1.0	ON	OFF	ON
1.5	ON	ON	OFF
2.0	ON	OFF	OFF
2.5	OFF	ON	ON
2.8	OFF	OFF	ON
3.0	OFF	ON	OFF
3.5	OFF	OFF	OFF

## 5. Off-line Function (EN Terminal):

If you turn on the Off-line function, the motor will enter a free state. You can adjust the motor shaft freely, and the pulse signal will be no response. If you turn it off, it will be back into automatic control mode

**Note: Generally, EN terminal is not connected.**

## 6. FAQ

1. Q: If the control signal is higher than 5V, how do I connect?

A: You need add a resistor in series

2. Q: After connected the power, why the motor doesn't work? The PWR Led has been ON.

A: Please check the power supply, it must higher than 9V. And make sure the I/O limited current is higher than 5mA

3. Q: How do we know the right order of the stepper motor?

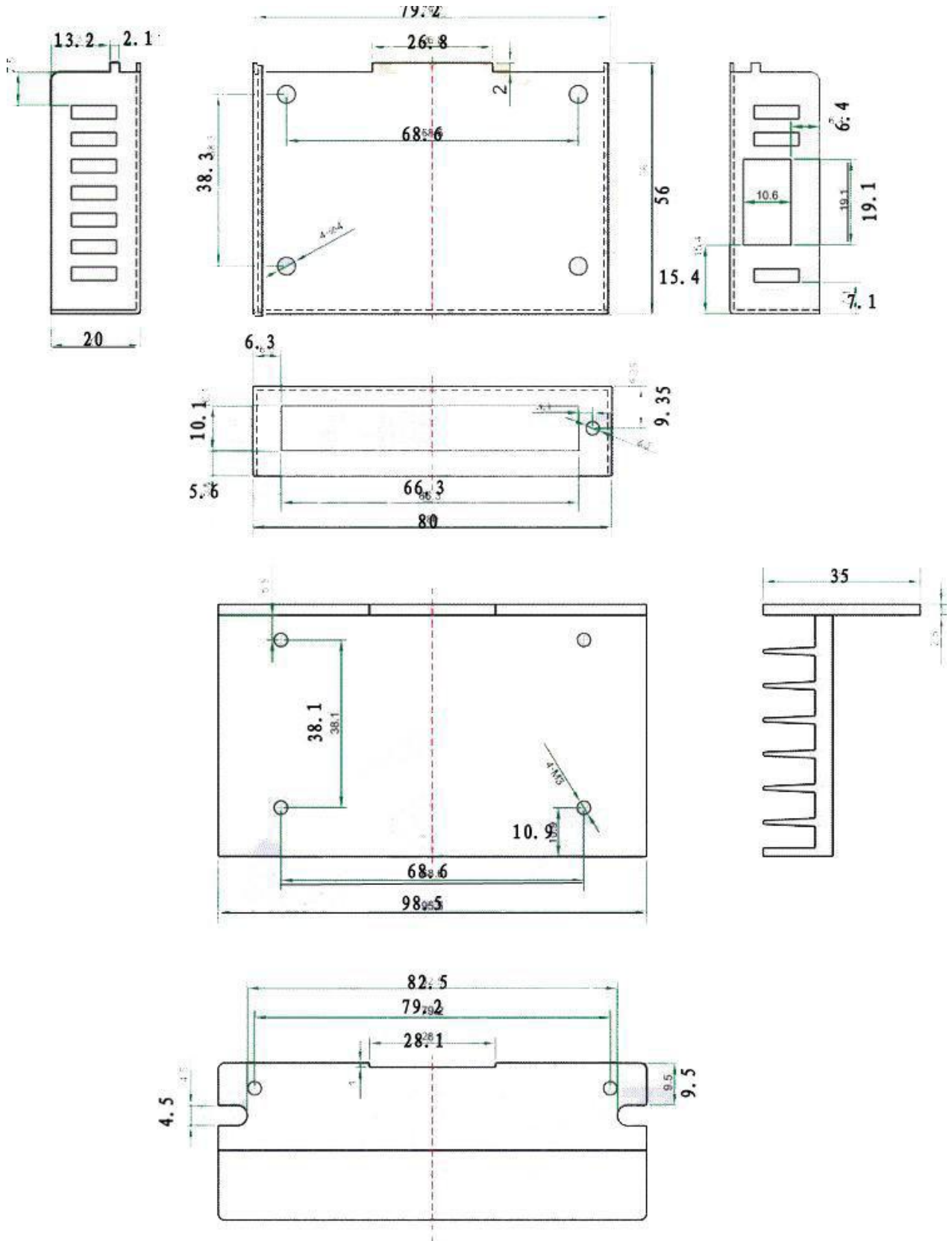

A: Please check the motor specification, it show you the right order. Or you can measure it with a multimeter.

## 7. Dimension (96\*56\*33)









## Looking for pricing, stock, or lifecycle information?

Click below to explore more details on WIN SOURCE:

-  [View DRI0043 on WIN SOURCE](#)
-  [DFRobot Information](#)

## Optimize Your Supply Chain with WIN SOURCE Solutions

-  Global Sourcing Solution
-  Obsolete Management
-  Cost Control Management
-  Shortage Management
-  Alternative Solution
-  Excess Inventory Management