



# THE DATASHEET OF TAS5731EVM



## 2 x 20-W DIGITAL AUDIO POWER AMPLIFIER WITH DSP AND 2.1 MODE

Check for Samples: [TAS5731](#)

### FEATURES

- 2-Ch I<sup>2</sup>S Input; 8-kHz to 48-kHz  $f_s$
- 20-W Stereo, 8  $\Omega$ /18 V (THD+N = 10%)
- Up to 90% Efficient Operation
- Wide 8-V to- 21-V Supply Range;  
3.3-V Digital Supply
- Single-Device 2.1 Support (2 x SE + 1 x BTL)
- 70-m $\Omega$   $R_{DS(on)}$  Device That Can Support 2- $\Omega$  SE and 4- $\Omega$  BTL Modes
  - 12 V / 2  $\Omega$  / 8 W With SE mode
  - 12 V / 4  $\Omega$  / 15 W With BTL mode
- Speaker EQ (8 BQ per Channel), 2x DRCs
- P2P Compatible With the TAS5727
- Benefits
  - Direct Connect to Digital Processor
  - High Output Power From a Standard Supply
  - Eliminates Need for Heat Sink
  - Advanced Processing Improves Audio Experience

### APPLICATIONS

- LCD TV
- LED TV
- Sound Bar

### DESCRIPTION

The TAS5731 is a 20-W, efficient, digital-audio stereo power amplifier for driving stereo bridge-tied speakers. One serial data input allows processing of up to two discrete audio channels and seamless integration to most digital audio processors and MPEG decoders. The device accepts a wide range of input data and data rates. A fully programmable data path routes these channels to the internal speaker drivers.

The TAS5731 is a slave-only device receiving all clocks from external sources. The TAS5731 operates with a PWM carrier between a 384-kHz switching rate and a 352-kHz switching rate, depending on the input sample rate. Oversampling combined with a fourth-order noise shaper provides a flat noise floor and excellent dynamic range from 20 Hz to 20 kHz.



Please be aware that an important notice concerning availability, standard warranty, and use in critical applications of Texas Instruments semiconductor products and disclaimers thereto appears at the end of this data sheet.



These devices have limited built-in ESD protection. The leads should be shorted together or the device placed in conductive foam during storage or handling to prevent electrostatic damage to the MOS gates.

### SIMPLIFIED 2.1 APPLICATION DIAGRAM

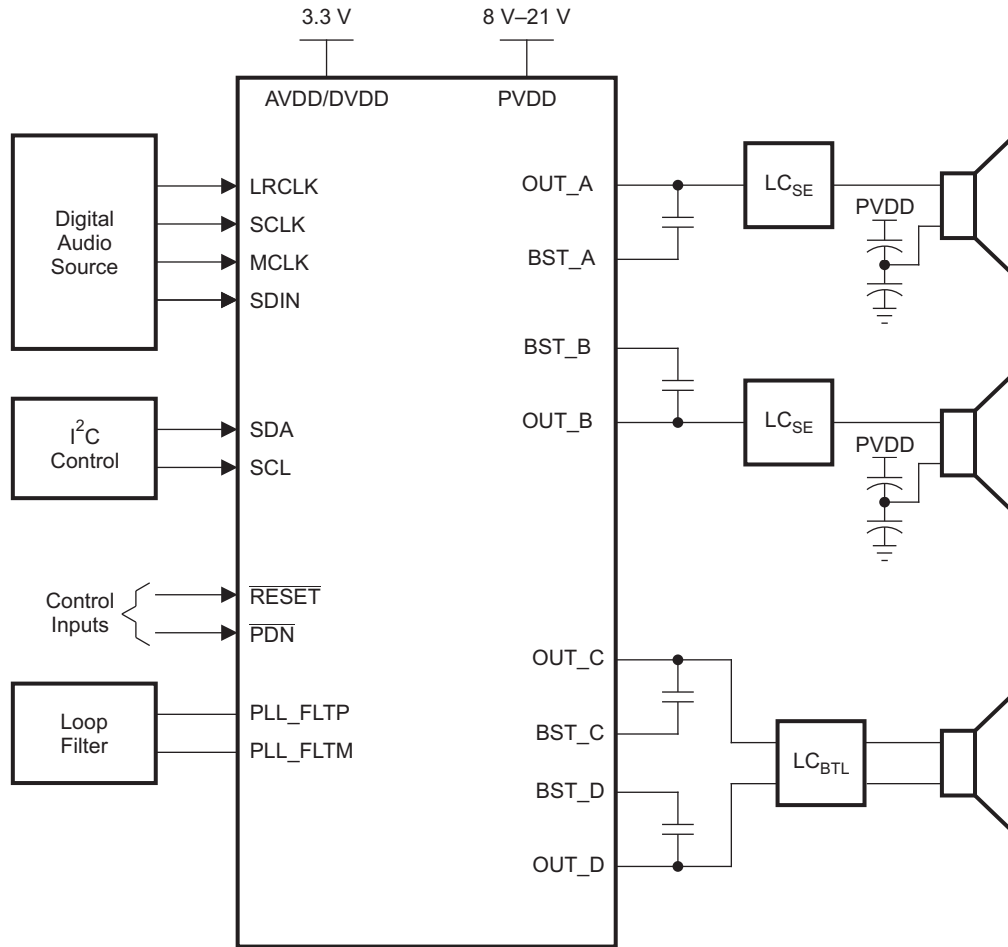

B0264-25

FUNCTIONAL VIEW

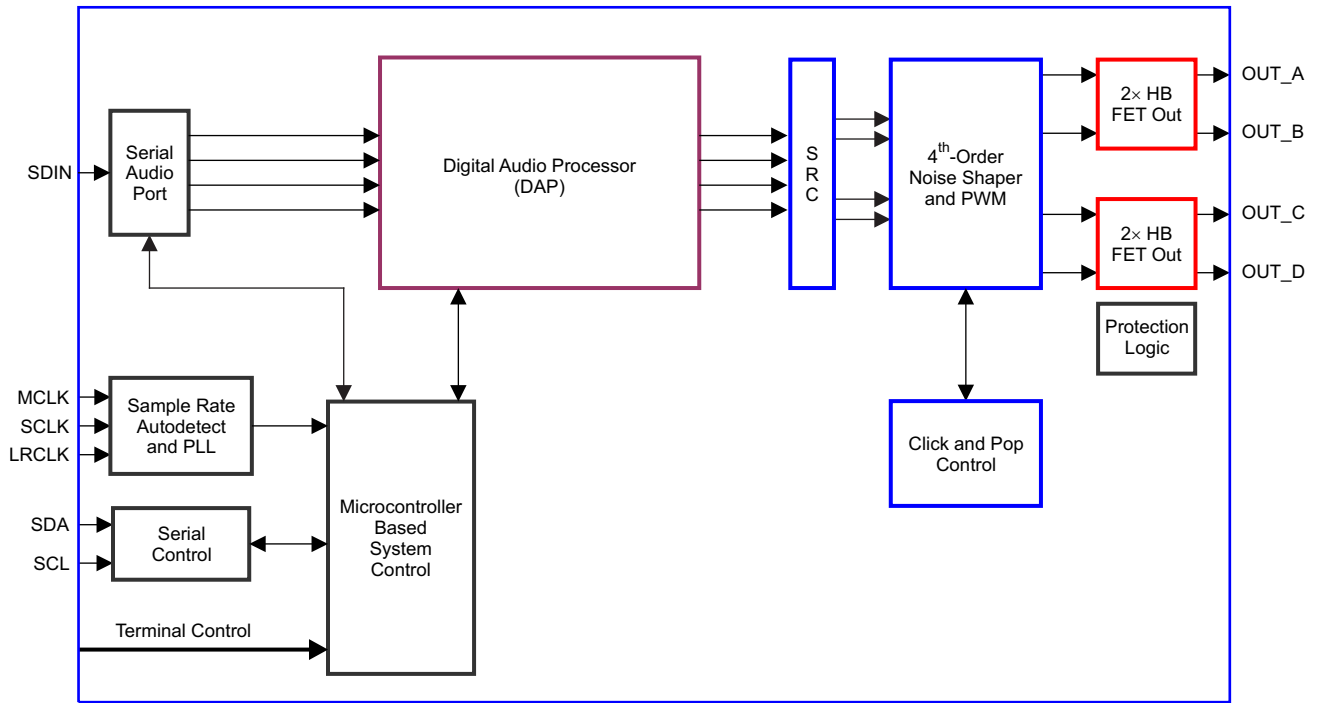

B0262-14

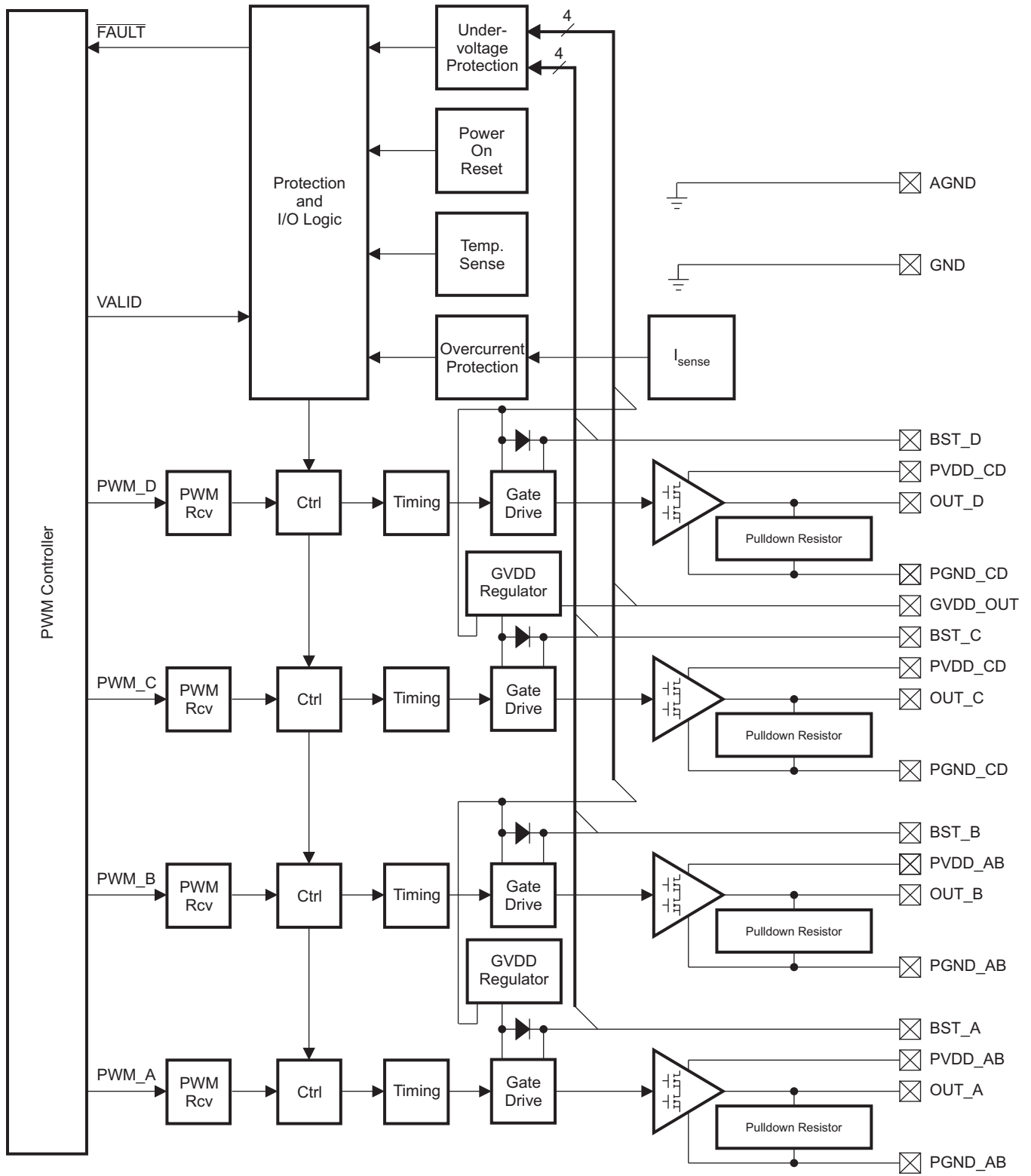

B0034-08

Figure 1. Power-Stage Functional Block Diagram



### DEVICE INFORMATION

PHP Package  
(Top View)

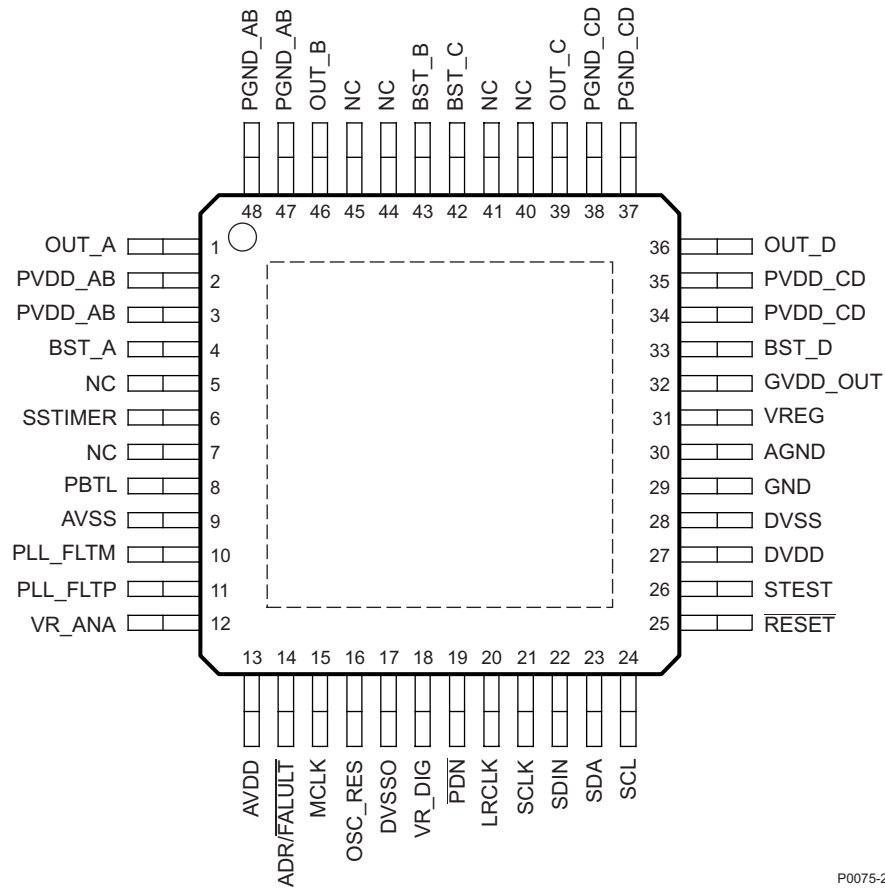

P0075-25

### PIN FUNCTIONS

PIN		TYPE <sup>(1)</sup>	5-V TOLERANT	TERMINATION <sup>(2)</sup>	DESCRIPTION
NAME	NO.				
AGND	30	P			Local analog ground for power stage, which should be connected to the system ground.
ADR/FAULT	14	DIO			Dual function terminal which sets the LSB of the 7-bit I <sup>2</sup> C address to "0" if pulled to GND and to "1" if pulled to DVDD. If configured to be a fault output by the methods described in <a href="#">I<sup>2</sup>C Address Selection and Fault Output</a> , this terminal is pulled low when an internal fault occurs. A pull-up or pull-down resistor is required, as is shown in the Typical Application Circuit Diagrams. If pulled high (to DVDD), a 15kΩ resistor should be used to minimize in-rush current at power up and to isolate the net if the pin is used as a fault output, as described above.
AVDD	13	P			3.3-V analog power supply
AVSS	9	P			Analog 3.3-V supply ground
BST_A	4	P			High-side bootstrap supply for half-bridge A
BST_B	43	P			High-side bootstrap supply for half-bridge B

(1) TYPE: A = analog; D = 3.3-V digital; P = power/ground/decoupling; I = input; O = output

(2) All pullups are 20-μA weak pullups and all pulldowns are 20-μA weak pulldowns. The pullups and pulldowns are included to assure proper input logic levels if the terminals are left unconnected (pull-ups → logic 1 input; pulldowns → logic 0 input). Devices that drive inputs with pullups must be able to sink 20 μA while maintaining a logic-0 drive level. Devices that drive inputs with pulldowns must be able to source 20 μA while maintaining a logic-1 drive level.

**PIN FUNCTIONS (continued)**

PIN		TYPE <sup>(1)</sup>	5-V TOLERANT	TERMINATION <sup>(2)</sup>	DESCRIPTION
NAME	NO.				
BST_C	42	P			High-side bootstrap supply for half-bridge C
BST_D	33	P			High-side bootstrap supply for half-bridge D
DVDD	27	P			3.3-V digital power supply
DVSS	28	P			Digital ground
DVSSO	17	P			Oscillator ground
GND	29	P			Analog ground for power stage
GVDD_OUT	32	P			Gate drive internal regulator output
LRCLK	20	DI	5-V	Pulldown	Input serial audio data left/right clock (sample-rate clock)
MCLK	15	DI	5-V	Pulldown	Master clock input
NC	5, 7, 40, 41, 44, 45	–			No connect
OSC_RES	16	AO			Oscillator trim resistor. Connect an 18.2-kΩ, 1% resistor to DVSSO.
OUT_A	1	O			Output, half-bridge A
OUT_B	46	O			Output, half-bridge B
OUT_C	39	O			Output, half-bridge C
OUT_D	36	O			Output, half-bridge D
PBTL	8	DI		Pulldown	Low means BTL mode; high means PBTL mode. Information goes directly to power stage.
$\overline{\text{PDN}}$	19	DI	5-V	Pullup	Power down, active-low. $\overline{\text{PDN}}$ prepares the device for loss of power supplies by shutting down the noise shaper and initiating the PWM stop sequence.
PGND_AB	47, 48	P			Power ground for half-bridges A and B
PGND_CD	37, 38	P			Power ground for half-bridges C and D
PLL_FLTM	10	AO			PLL negative loop-filter terminal
PLL_FLTP	11	AO			PLL positive loop-filter terminal
PVDD_AB	2, 3	P			Power-supply input for half-bridge output A and B
PVDD_CD	34, 35	P			Power-supply input for half-bridge output C and D
$\overline{\text{RESET}}$	25	DI	5-V	Pullup	Reset, active-low. A system reset is generated by applying a logic low to this pin. RESET is an asynchronous control signal that restores the DAP to its default conditions and places the PWM in the hard-mute (high-impedance) state.
SCL	24	DI	5-V		I <sup>2</sup> C serial control clock input
SCLK	21	DI	5-V	Pulldown	Serial audio-data clock (shift clock). SCLK is the serial-audio-port input-data bit clock.
SDA	23	DIO	5-V		I <sup>2</sup> C serial control data interface input/output
SDIN	22	DI	5-V	Pulldown	Serial audio data input. SDIN supports three discrete (stereo) data formats.
SSTIMER	6	AI			Controls ramp time of OUT_x to minimize pop. Leave this pin floating for BD mode. Requires capacitor of 2.2 nF to GND in AD mode. The capacitor determines the ramp time.
STEST	26	DI			Factory test pin. Connect directly to DVSS.
VR_ANA	12	P			Internally regulated 1.8-V analog supply voltage. This pin must not be used to power external devices.
VR_DIG	18	P			Internally regulated 1.8-V digital supply voltage. This pin must not be used to power external devices.
VREG	31	P			Digital regulator output. Not to be used for powering external circuitry.

## ABSOLUTE MAXIMUM RATINGS

over operating free-air temperature range (unless otherwise noted) <sup>(1)</sup>

		VALUE	UNIT
Supply voltage	DVDD, AVDD	-0.3 to 3.6	V
	PVDD_x	-0.3 to 30	V
Input voltage	3.3-V digital input	-0.5 to DVDD + 0.5	V
	5-V tolerant <sup>(2)</sup> digital input (except MCLK)	-0.5 to DVDD + 2.5 <sup>(3)</sup>	
	5-V tolerant MCLK input	-0.5 to AVDD + 2.5 <sup>(3)</sup>	
OUT_x to PGND_x		27 <sup>(4)</sup>	V
BST_x to PGND_x		34 <sup>(4)</sup>	V
Input clamp current, I <sub>IK</sub>		±20	mA
Output clamp current, I <sub>OK</sub>		±20	mA
Operating free-air temperature		0 to 85	°C
Operating junction temperature range		0 to 150	°C
Storage temperature range, T <sub>stg</sub>		-40 to 125	°C

- (1) Stresses beyond those listed under *Absolute Maximum Ratings* may cause permanent damage to the device. These are stress ratings only and functional operation of the device at these or any other conditions beyond those indicated under *Recommended Operating Conditions* is not implied. Exposure to absolute-maximum conditions for extended periods may affect device reliability.
- (2) 5-V tolerant inputs are PDN, RESET, SCLK, LRCLK, MCLK, SDIN, SDA, and SCL.
- (3) Maximum pin voltage should not exceed 6 V.
- (4) DC voltage + peak ac waveform measured at the pin should be below the allowed limit for all conditions.

## THERMAL INFORMATION

THERMAL METRIC <sup>(1)</sup>		TAS5731	UNIT
		PHP (48 PINS)	
$\theta_{JA}$	Junction-to-ambient thermal resistance	27.9	°C/W
$\theta_{JB}$	Junction-to-board thermal resistance	13	°C/W
$\theta_{JC(bottom)}$	Junction-to-case (bottom) thermal resistance	1.1	°C/W
$\theta_{JC(top)}$	Junction-to-case (top) thermal resistance	20.7	°C/W
$\psi_{JT}$	Junction-to-top characterization parameter	0.3	°C/W
$\psi_{JB}$	Junction-to-board characterization parameter	6.7	°C/W

- (1) For more information about traditional and new thermal metrics, see the *IC Package Thermal Metrics* application report, [SPRA953](#).

## RECOMMENDED OPERATING CONDITIONS

		MIN	NOM	MAX	UNIT	
	Digital/analog supply voltage	DVDD, AVDD	3	3.3	3.6	V
	Half-bridge supply voltage	PVDD_x	8	21.5 <sup>(1)</sup>		V
V <sub>IH</sub>	High-level input voltage	5-V tolerant	2			V
V <sub>IL</sub>	Low-level input voltage	5-V tolerant		0.8		V
T <sub>A</sub>	Operating ambient temperature range		0	85		°C
T <sub>J</sub> <sup>(2)</sup>	Operating junction temperature range		0	125		°C
R <sub>L</sub> (PBTL)	Load impedance	Output filter: L = 15 $\mu$ H, C = 680 nF, PVDD_x $\leq$ 13 V	3			$\Omega$
		Output filter: L = 15 $\mu$ H, C = 680 nF, PVDD_x > 13 V	4			
R <sub>L</sub> (BTL)	Load impedance	Output filter: L = 15 $\mu$ H, C = 680 nF	4			$\Omega$
R <sub>L</sub> (SE)	Load impedance	Output filter: L = 15 $\mu$ H, C = 680 nF, PVDD_x $\leq$ 13 V	2			$\Omega$
		Output filter: L = 15 $\mu$ H, C = 680 nF, PVDD_x > 13 V	4			

- (1) For operation at PVDD\_x levels greater than 18V, the modulation limit must be set to 93.8% via the control port register 0x10.

- (2) Continuous operation above the recommended junction temperature may result in reduced reliability and/or lifetime of the device.

**RECOMMENDED OPERATING CONDITIONS (continued)**

		MIN	NOM	MAX	UNIT
$L_O$	Output-filter inductance	Minimum output inductance under short-circuit condition			$\mu\text{H}$
		10			

**PWM OPERATION AT RECOMMENDED OPERATING CONDITIONS**

PARAMETER	TEST CONDITIONS	VALUE	UNIT
Output PWM switch frequency	11.025/22.05/44.1-kHz data rate $\pm 2\%$	352.8	kHz
	48/24/12/8/16/32-kHz data rate $\pm 2\%$	384	

**PLL INPUT PARAMETERS AND EXTERNAL FILTER COMPONENTS**

PARAMETER	TEST CONDITIONS	MIN	TYP	MAX	UNIT
$f_{\text{MCLKI}}$ MCLK frequency		2.8224		24.576	MHz
MCLK duty cycle		40%	50%	60%	
$t_r / t_f$ / $t_{f(\text{MCLK})}$ Rise/fall time for MCLK				5	ns
LRCLK allowable drift before LRCLK reset				4	MCLKs
External PLL filter capacitor C1	SMD 0603 X7R		47		nF
External PLL filter capacitor C2	SMD 0603 X7R		4.7		nF
External PLL filter resistor R	SMD 0603, metal film		470		$\Omega$

**ELECTRICAL CHARACTERISTICS**
**DC Characteristics**
 $T_A = 25^\circ$ ,  $PVCC\_X = 18\text{ V}$ ,  $DVDD = AVDD = 3.3\text{ V}$ ,  $R_L = 8\ \Omega$ , BTL AD mode,  $f_s = 48\text{ kHz}$  (unless otherwise noted)

PARAMETER	TEST CONDITIONS	MIN	TYP	MAX	UNIT
$V_{OH}$ High-level output voltage	ADR/ $\overline{\text{FAULT}}$ and SDA $I_{OH} = -4\text{ mA}$ DVDD = 3 V	2.4			V
$V_{OL}$ Low-level output voltage	ADR/ $\overline{\text{FAULT}}$ and SDA $I_{OL} = 4\text{ mA}$ DVDD = 3 V			0.5	V
$I_{IL}$ Low-level input current	$V_I < V_{IL}$ ; DVDD = AVDD = 3.6V			75	$\mu\text{A}$
$I_{IH}$ High-level input current	$V_I > V_{IH}$ ; DVDD = AVDD = 3.6V			75 <sup>(1)</sup>	$\mu\text{A}$
$I_{DD}$ 3.3 V supply current	3.3 V supply voltage (DVDD, AVDD)	Normal mode	49	68	mA
		Reset ( $\overline{\text{RESET}} = \text{low}$ , PDN = high)	23	38	
$I_{PVDD}$ Supply current	No load (PVDD_x)	Normal mode	32	50	mA
		Reset ( $\overline{\text{RESET}} = \text{low}$ , PDN = high)	3	8	
$r_{DS(on)}$ <sup>(2)</sup>	Drain-to-source resistance, LS	$T_J = 25^\circ\text{C}$ , includes metallization resistance			m $\Omega$
	Drain-to-source resistance, HS	$T_J = 25^\circ\text{C}$ , includes metallization resistance			
<b>I/O Protection</b>					
$V_{uvp}$ Undervoltage protection limit	PVDD falling		6.4		V
$V_{uvp,hyst}$ Undervoltage protection limit	PVDD rising		7.1		V
OTE <sup>(3)</sup> Overtemperature error			150		$^\circ\text{C}$
OTE <sub>HYST</sub> <sup>(3)</sup> Extra temperature drop required to recover from error			30		$^\circ\text{C}$
$I_{OC}$ Overcurrent limit protection	Output to output short in BTL mode		4.5		A
$I_{OCT}$ Overcurrent response time			150		ns

(1)  $I_{IH}$  for the PBTL pin has a maximum limit of 200  $\mu\text{A}$  due to an internal pulldown on the pin.

(2) This does not include bond-wire or pin resistance.

(3) Specified by design

## AC Characteristics (BTL, PBTL)

PVDD<sub>x</sub> = 18 V, BTL AD mode,  $f_s = 48$  KHz,  $R_L = 8 \Omega$ ,  $C_{BST} = 33$  nF, audio frequency = 1 kHz, AES17 filter,  $f_{PWM} = 384$  kHz,  $T_A = 25^\circ\text{C}$  (unless otherwise specified). All performance is in accordance with recommended operating conditions (unless otherwise specified).

PARAMETER		TEST CONDITIONS	MIN	TYP	MAX	UNIT
P <sub>O</sub>	Power output per channel	BTL mode, PVDD = 8 V, 7% THD		4		W
		BTL mode, PVDD = 8 V, 10% THD		4.2		
		BTL mode, PVDD = 12 V, 7% THD		9.1		
		BTL mode, PVDD = 12 V, 10% THD		9.6		
		BTL mode, PVDD = 18 V, 7% THD		19.8		
		BTL mode, PVDD = 18 V, 10% THD		20.9		
		PBTL mode, PVDD = 12 V, $R_L = 4 \Omega$ , 7% THD		17.7		
		PBTL mode, PVDD = 12 V, $R_L = 4 \Omega$ , 10% THD		18.7		
		PBTL mode, PVDD = 18 V, $R_L = 4 \Omega$ , 7% THD		39		
		PBTL mode, PVDD = 18 V, $R_L = 4 \Omega$ , 10% THD		41.5		
		SE Mode, PVDD = 12 V, $R_L = 4 \Omega$ , 7% THD		4.3		
		SE Mode, PVDD = 12 V, $R_L = 4 \Omega$ , 10% THD		4.6		
		SE Mode, PVDD = 18 V, $R_L = 4 \Omega$ , 7% THD		16.8		
		SE Mode, PVDD = 18 V, $R_L = 4 \Omega$ , 10% THD		17.8		
THD+N	Total harmonic distortion + noise	PVDD = 8 V, P <sub>O</sub> = 1 W		0.1		%
		PVDD = 12 V, P <sub>O</sub> = 1 W		0.07		
		PVDD = 18 V, P <sub>O</sub> = 1 W		0.03		
V <sub>n</sub>	Output integrated noise (rms)	A-weighted		56		$\mu\text{V}$
	Cross-talk	P <sub>O</sub> = 0.25 W, f = 1 kHz (AD Mode)		-69		dB
SNR	Signal-to-noise ratio <sup>(1)</sup>	A-weighted, f = 1 kHz, maximum power at THD < 1%		106		dB

(1) SNR is calculated relative to 0-dBFS input level.

## SERIAL AUDIO PORTS SLAVE MODE

over recommended operating conditions (unless otherwise noted)

PARAMETER		TEST CONDITIONS	MIN	TYP	MAX	UNIT
$f_{SCLKIN}$	Frequency, SCLK $32 \times f_S$ , $48 \times f_S$ , $64 \times f_S$	$C_L = 30 \text{ pF}$	1.024		12.288	MHz
$t_{su1}$	Setup time, LRCLK to SCLK rising edge		10			ns
$t_{h1}$	Hold time, LRCLK from SCLK rising edge		10			ns
$t_{su2}$	Setup time, SDIN to SCLK rising edge		10			ns
$t_{h2}$	Hold time, SDIN from SCLK rising edge		10			ns
	LRCLK frequency		8	48	48	kHz
	SCLK duty cycle		40%	50%	60%	
	LRCLK duty cycle		40%	50%	60%	
	SCLK rising edges between LRCLK rising edges		32		64	SCLK edges
$t_{(edge)}$	LRCLK clock edge with respect to the falling edge of SCLK		-1/4		1/4	SCLK period
$t_r/t_f$	Rise/fall time for SCLK/LRCLK				8	ns

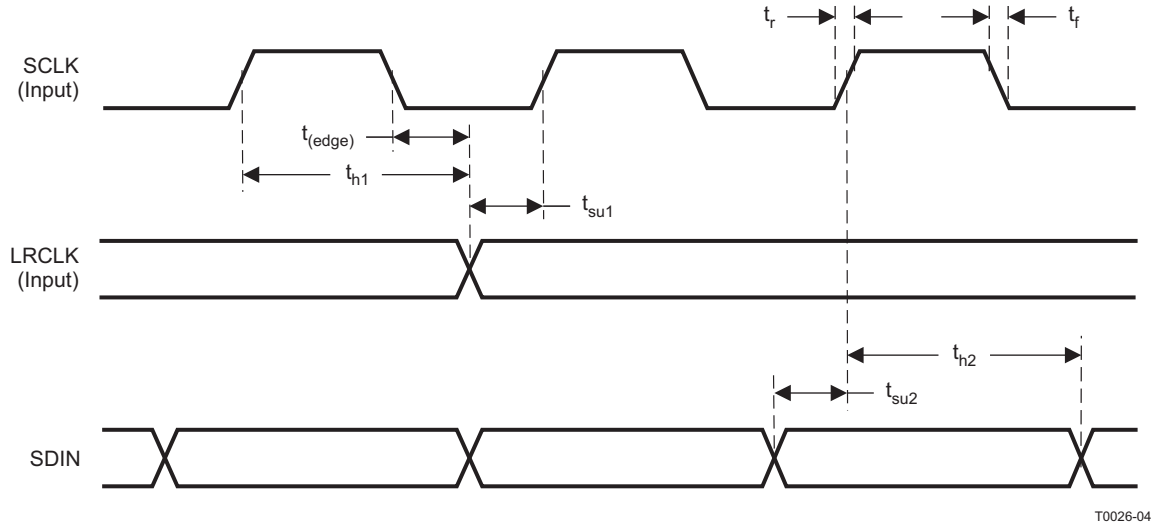

Figure 2. Slave-Mode Serial Data-Interface Timing

## I<sup>2</sup>C SERIAL CONTROL PORT OPERATION

Timing characteristics for I<sup>2</sup>C Interface signals over recommended operating conditions (unless otherwise noted)

PARAMETER		TEST CONDITIONS	MIN	MAX	UNIT
f <sub>SCL</sub>	Frequency, SCL	No wait states		400	kHz
t <sub>w(H)</sub>	Pulse duration, SCL high		0.6		μs
t <sub>w(L)</sub>	Pulse duration, SCL low		1.3		μs
t <sub>r</sub>	Rise time, SCL and SDA			300	ns
t <sub>f</sub>	Fall time, SCL and SDA			300	ns
t <sub>su1</sub>	Setup time, SDA to SCL		100		ns
t <sub>h1</sub>	Hold time, SCL to SDA		0		ns
t <sub>(buf)</sub>	Bus free time between stop and start conditions		1.3		μs
t <sub>su2</sub>	Setup time, SCL to start condition		0.6		μs
t <sub>h2</sub>	Hold time, start condition to SCL		0.6		μs
t <sub>su3</sub>	Setup time, SCL to stop condition		0.6		μs
C <sub>L</sub>	Load capacitance for each bus line			400	pF

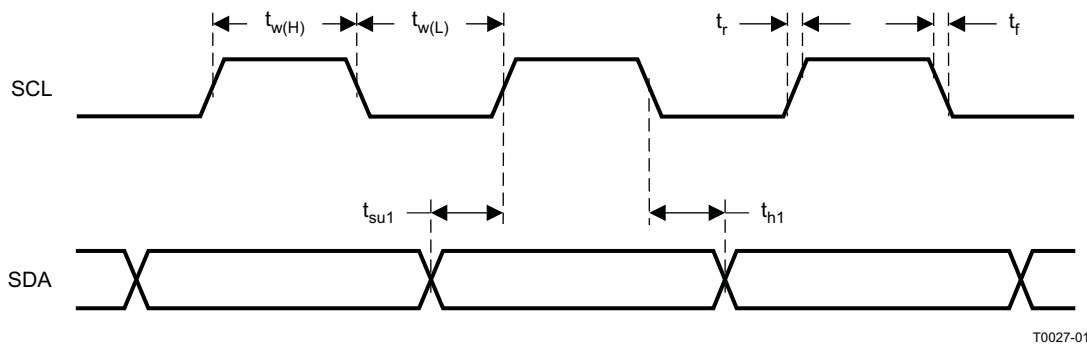

Figure 3. SCL and SDA Timing

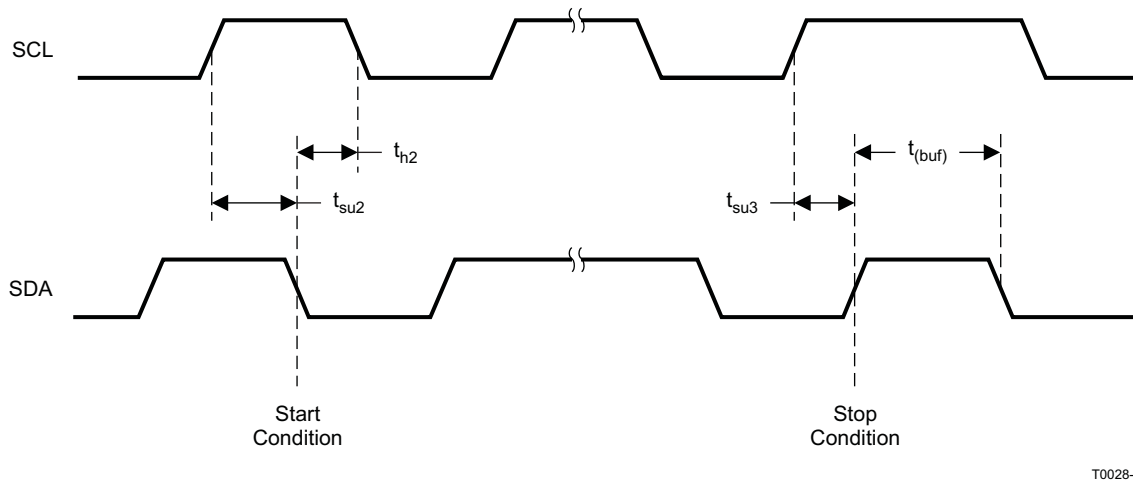
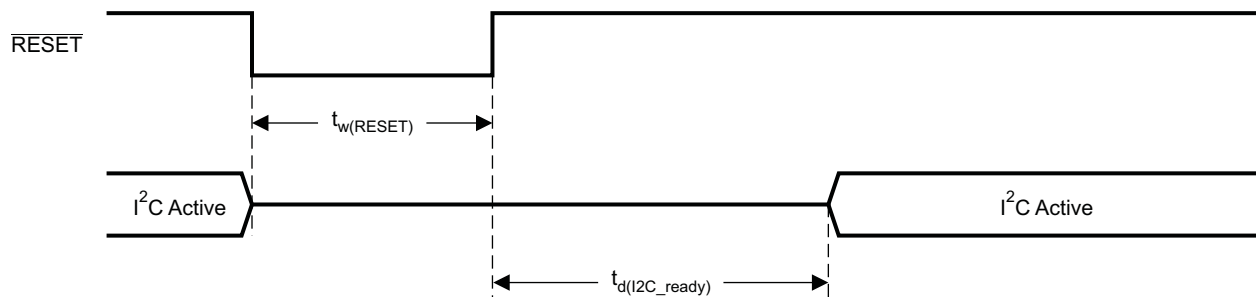

Figure 4. Start and Stop Conditions Timing

## RESET TIMING ( $\overline{\text{RESET}}$ )

Control signal parameters over recommended operating conditions (unless otherwise noted). Please refer to Recommended Use Model section on usage of all terminals.

PARAMETER		MIN	TYP	MAX	UNIT
$t_w(\overline{\text{RESET}})$	Pulse duration, $\overline{\text{RESET}}$ active	100			$\mu\text{s}$
$t_d(\text{I}^2\text{C\_ready})$	Time to enable I <sup>2</sup> C			12	ms



System Initialization.  
Enable via I<sup>2</sup>C.

T0421-01

NOTES: On power up, it is recommended that the TAS5731  $\overline{\text{RESET}}$  be held LOW for at least 100  $\mu\text{s}$  after DVDD has reached 3 V.

If  $\overline{\text{RESET}}$  is asserted LOW while  $\overline{\text{PDN}}$  is LOW, then  $\overline{\text{RESET}}$  must continue to be held LOW for at least 100  $\mu\text{s}$  after  $\overline{\text{PDN}}$  is deasserted (HIGH).

Figure 5. Reset Timing

**TYPICAL CHARACTERISTICS, SE CONFIGURATION, 4 Ω**

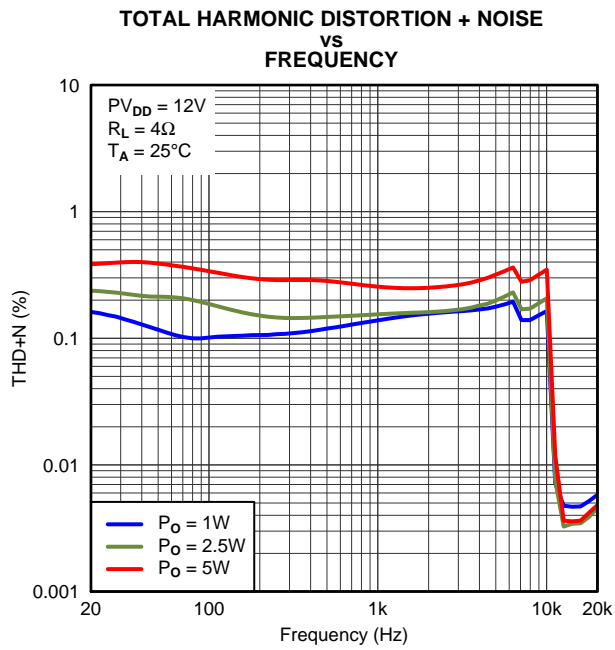

Figure 6.

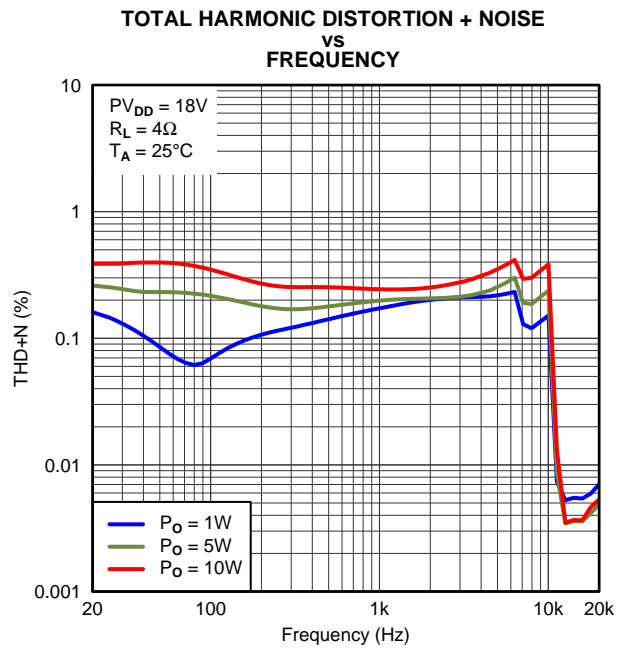

Figure 7.

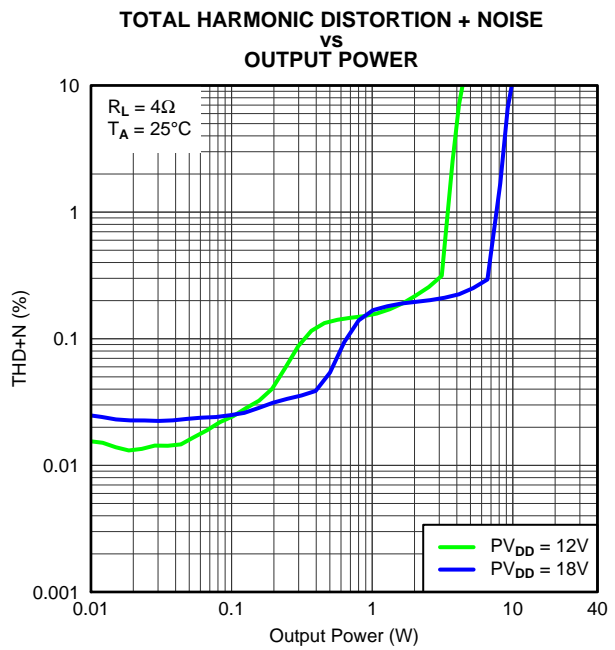

Figure 8.

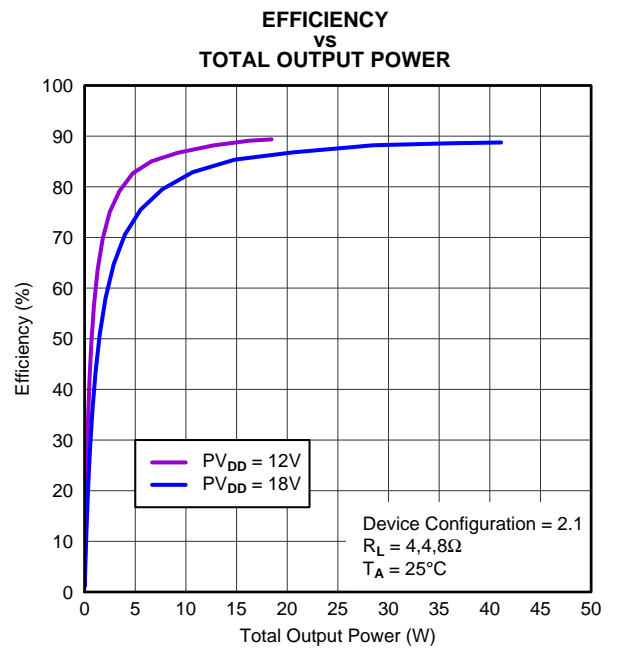

Figure 9.

TYPICAL CHARACTERISTICS, BTL CONFIGURATION, 8 Ω

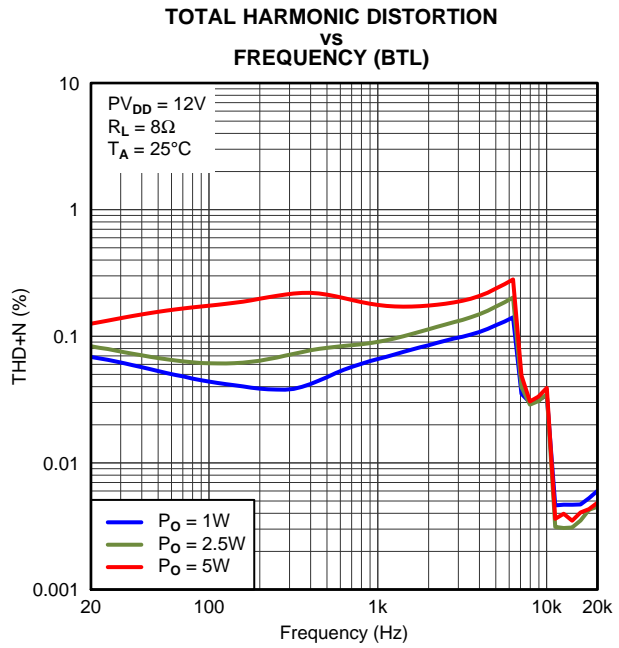

Figure 10.

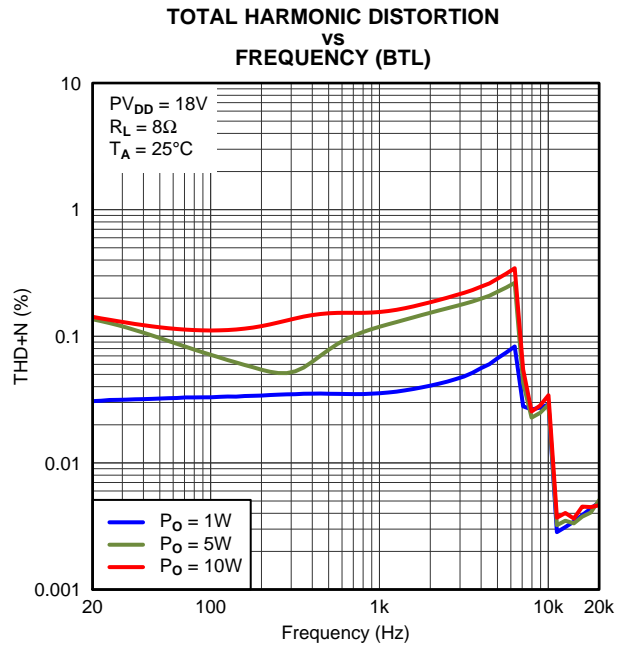

Figure 11.

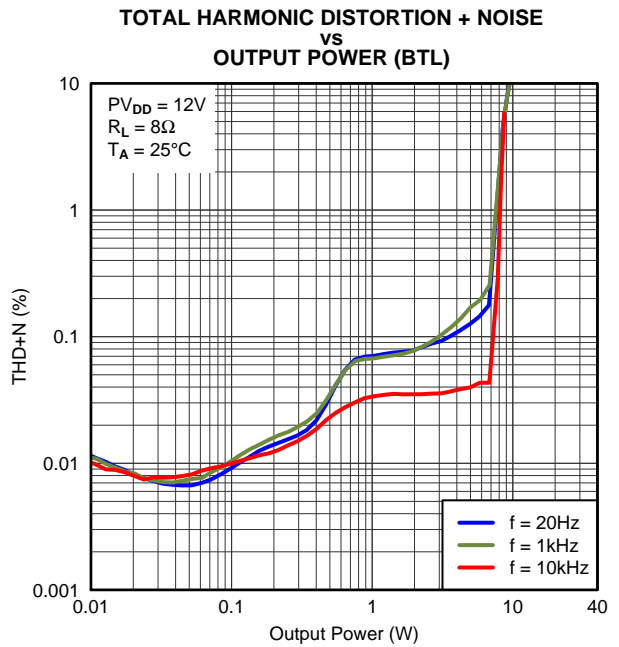

Figure 12.

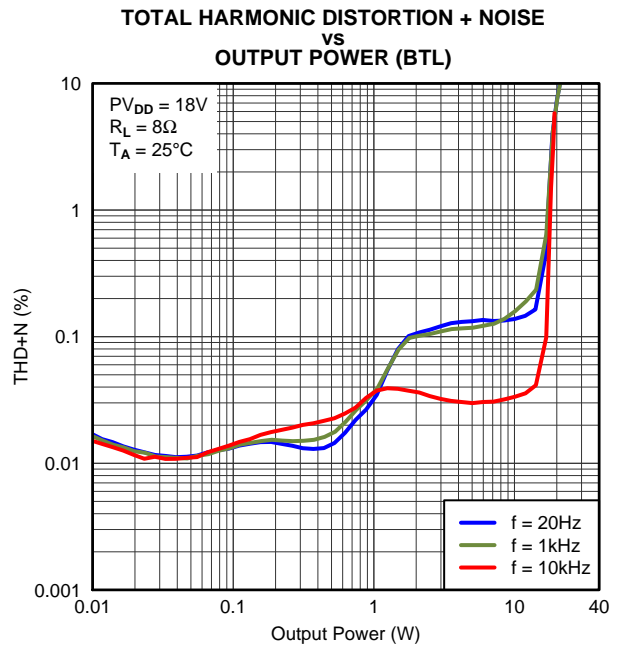

Figure 13.

**TYPICAL CHARACTERISTICS, BTL CONFIGURATION, 8 Ω (continued)**

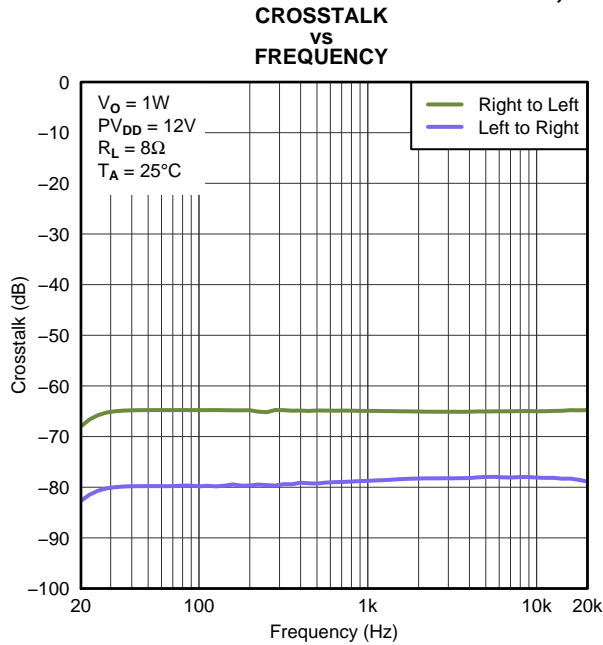

Figure 14.

G007

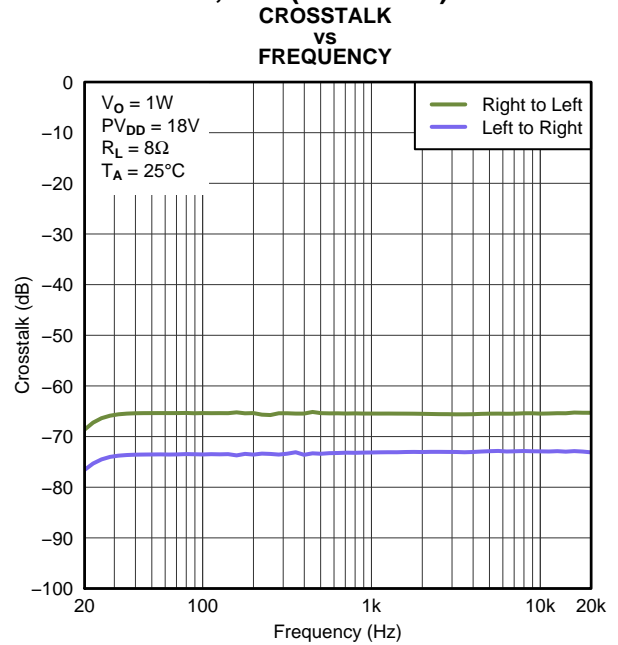

Figure 15.

G008

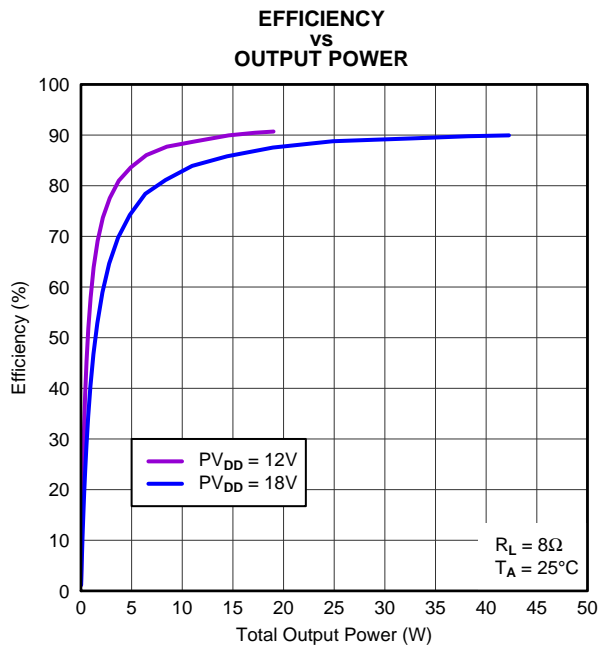

Figure 16.

G010

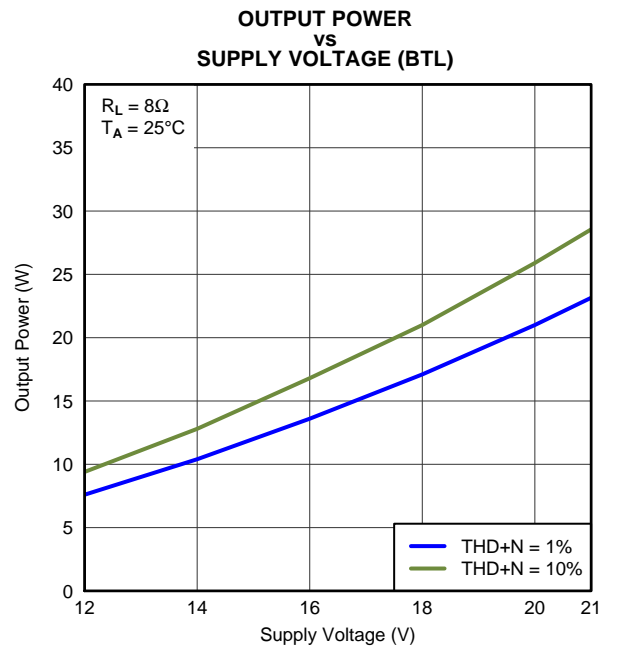

Figure 17.

G011

**DETAILED DESCRIPTION**

**POWER SUPPLY**

To facilitate system design, the TAS5731 needs only a 3.3-V supply in addition to the (typical) 18-V power-stage supply. An internal voltage regulator provides suitable voltage levels for the gate drive circuitry. Additionally, all circuitry requiring a floating voltage supply, e.g., the high-side gate drive, is accommodated by built-in bootstrap circuitry requiring only a few external capacitors.

In order to provide good electrical and acoustical characteristics, the PWM signal path for the output stage is designed as identical, independent half-bridges. For this reason, each half-bridge has separate bootstrap pins (BST\_x), and power-stage supply pins (PVDD\_x). The gate-drive voltage (GVDD\_OUT) is derived from the PVDD voltage. Special attention should be paid to placing all decoupling capacitors as close to their associated pins as possible. Inductance between the power-supply pins and decoupling capacitors must be avoided.

For a properly functioning bootstrap circuit, a small ceramic capacitor must be connected from each bootstrap pin (BST\_x) to the power-stage output pin (OUT\_x). When the power-stage output is low, the bootstrap capacitor is charged through an internal diode connected between the gate-drive regulator output pin (GVDD\_OUT) and the bootstrap pin. When the power-stage output is high, the bootstrap capacitor potential is shifted above the output potential and thus provides a suitable voltage supply for the high-side gate driver. In an application with PWM switching frequencies in the range from 288 kHz to 384 kHz, it is recommended to use 33-nF, X7R ceramic capacitors, size 0603 or 0805, for the bootstrap supply. These 33-nF capacitors ensure sufficient energy storage, even during minimal PWM duty cycles, to keep the high-side power-stage FET (LDMOS) fully turned on during the remaining part of the PWM cycle.

Special attention should be paid to the power-stage power supply; this includes component selection, PCB placement, and routing. As indicated, each half-bridge has independent power-stage supply pins (PVDD\_x). For optimal electrical performance, EMI compliance, and system reliability, it is important that each PVDD\_x pin is decoupled with a 100-nF, X7R ceramic capacitor placed as close as possible to each supply pin.

The TAS5731 is fully protected against erroneous power-stage turnon due to parasitic gate charging.

## I<sup>2</sup>C Address Selection and Fault Output

ADR/ $\overline{\text{FAULT}}$  is an input pin during power up. It can be pulled HIGH or LOW through a resistor as shown in the Typical Application Circuit section in order to set the I<sup>2</sup>C address. Pulling this pin HIGH through the resistor results in setting the I<sup>2</sup>C 7-bit address to 0011011 (0x36), and pulling it LOW through the resistor results in setting the address to 0011010 (0x34).

During power up, the address of the device is latched in, freeing up the ADR/ $\overline{\text{FAULT}}$  pin to be used as a fault notification output. When configured as a fault output, the pin will go low when a fault occurs and will return to its default state when register 0x02 is cleared. The behavior of the pin in response to a fault condition is to be pulled low immediately upon an error. The device then waits for a period of time determined by BKND\_ERR Register (0x1C) before attempting to resume playback. If the error has been cleared when the device attempts to resume playback, playback will resume, the ADR/ $\overline{\text{FAULT}}$  pin will remain high, and normal operation will resume. If the error has not been removed, then the device will immediately re-enter the protected state and wait again for the predetermined period of time to pass. The device will pull the fault pin low for over-current, over-temperature, and under-voltage lock-out.

## SINGLE-FILTER PBTL MODE

The TAS5731 supports parallel BTL (PBTL) mode with OUT\_A/OUT\_B (and OUT\_C/OUT\_D) connected before the LC filter. In order to put the part in PBTL configuration, drive PBTL (pin 8) HIGH. This synchronizes the turnoff of half-bridges A and B (and similarly C/D) if an overcurrent condition is detected in either half-bridge. There is a pulldown resistor on the PBTL pin that configures the part in BTL mode if the pin is left floating.

PWM output multiplexers should be updated to set the device in PBTL mode. Output Mux Register (0x25) should be written with a value of 0x0110 3245.

## DEVICE PROTECTION SYSTEM

### Overcurrent (OC) Protection With Current Limiting

The device has independent, fast-reacting current detectors on all high-side and low-side power-stage FETs. The detector outputs are closely monitored by a protection system. If the high-current condition situation persists, i.e., the power stage is being overloaded, a protection system triggers a latching shutdown, resulting in the power stage being set in the high-impedance (Hi-Z) state. The device returns to normal operation once the fault condition (i.e., a short circuit on the output) is removed. Current-limiting and overcurrent protection are not independent for half-bridges. That is, if the bridge-tied load between half-bridges A and B causes an overcurrent fault, half-bridges A, B, C, and D are shut down.

## Overtemperature Protection

The TAS5731 has an overtemperature-protection system. If the device junction temperature exceeds 150°C (nominal), the device is put into thermal shutdown, resulting in all half-bridge outputs being set in the high-impedance (Hi-Z) state. The TAS5731 recovers automatically once the temperature drops approximately 30°C.

## Undervoltage Protection (UVP) and Power-On Reset (POR)

The UVP and POR circuits of the TAS5731 fully protect the device in any power-up/down and brownout situation. While powering up, the POR circuit resets the overload circuit (OLP) and ensures that all circuits are fully operational when the PVDD and AVDD supply voltages reach 7.6 V and 2.7 V, respectively. Although PVDD and AVDD are independently monitored, a supply-voltage drop below the UVP threshold on AVDD or either PVDD pin results in all half-bridge outputs immediately being set in the high-impedance (Hi-Z) state.

## SSTIMER FUNCTIONALITY

The SSTIMER pin uses a capacitor connected between this pin and ground to control the output duty cycle when exiting all-channel shutdown. The capacitor on the SSTIMER pin is slowly charged through an internal current source, and the charge time determines the rate at which the output transitions from a near-zero duty cycle to the desired duty cycle. This allows for a smooth transition that minimizes audible pops and clicks. When the part is shut down, the drivers are placed in the high-impedance state and transition slowly down through a 3-k $\Omega$  resistor, similarly minimizing pops and clicks. The shutdown transition time is independent of the SSTIMER pin capacitance. Larger capacitors increase the start-up time, while capacitors smaller than 2.2 nF decrease the start-up time. The SSTIMER pin should be left floating for BD modulation.

## CLOCK, AUTODETECTION, AND PLL

The TAS5731 is an I<sup>2</sup>S slave device. It accepts MCLK, SCLK, and LRCLK. The digital audio processor (DAP) supports all the sample rates and MCLK rates that are defined in the [clock control register](#).

The TAS5731 checks to verify that SCLK is a specific value of 32 f<sub>S</sub>, 48 f<sub>S</sub>, or 64 f<sub>S</sub>. The DAP only supports a 1 × f<sub>S</sub> LRCLK. The timing relationship of these clocks to SDIN is shown in subsequent sections. The clock section uses MCLK or the internal oscillator clock (when MCLK is unstable, out of range, or absent) to produce the internal clock (DCLK) running at 512 times the PWM switching frequency.

The DAP can autodetect and set the internal clock control logic to the appropriate settings for all supported clock rates as defined in the clock-control register.

The TAS5731 has robust clock error handling that uses the built-in trimmed oscillator clock to quickly detect changes/errors. Once the system detects a clock change/error, it mutes the audio (through a single-step mute) and then forces PLL to limp using the internal oscillator as a reference clock. Once the clocks are stable, the system autodetects the new rate and reverts to normal operation. During this process, the default volume is restored in a single step (also called hard unmute). The ramp process can be programmed to ramp back slowly (also called soft unmute) as defined in volume register (0x0E).

## SERIAL DATA INTERFACE

Serial data is input on SDIN. The PWM outputs are derived from SDIN. The TAS5731 DAP accepts serial data in 16-, 20-, or 24-bit left-justified, right-justified, and I<sup>2</sup>S serial data formats.

## PWM SECTION

The TAS5731 DAP device uses noise-shaping and customized nonlinear correction algorithms to achieve high power efficiency and high-performance digital audio reproduction. The DAP uses a fourth-order noise shaper to increase dynamic range and SNR in the audio band. The PWM section accepts 24-bit PCM data from the DAP and outputs two BTL PWM audio output channels.

The PWM section has individual-channel dc-blocking filters that can be enabled and disabled. The filter cutoff frequency is less than 1 Hz. Individual-channel de-emphasis filters for 44.1 kHz and 48 kHz are included and can be enabled and disabled.

Finally, the PWM section has an adjustable maximum modulation limit of 93.8% to 99.2%.

For a detailed description of using audio processing features like DRC and EQ, see the User's Guide and TAS570X GDE software development tool documentation.

## SERIAL INTERFACE CONTROL AND TIMING

### I<sup>2</sup>S Timing

I<sup>2</sup>S timing uses LRCLK to define when the data being transmitted is for the left channel and when it is for the right channel. LRCLK is low for the left channel and high for the right channel. A bit clock running at  $32, 48, \text{ or } 64 \times f_s$  is used to clock in the data. There is a delay of one bit clock from the time the LRCLK signal changes state to the first bit of data on the data lines. The data is written MSB-first and is valid on the rising edge of bit clock. The DAP masks unused trailing data bit positions.

2-Channel I<sup>2</sup>S (Philips Format) Stereo Input

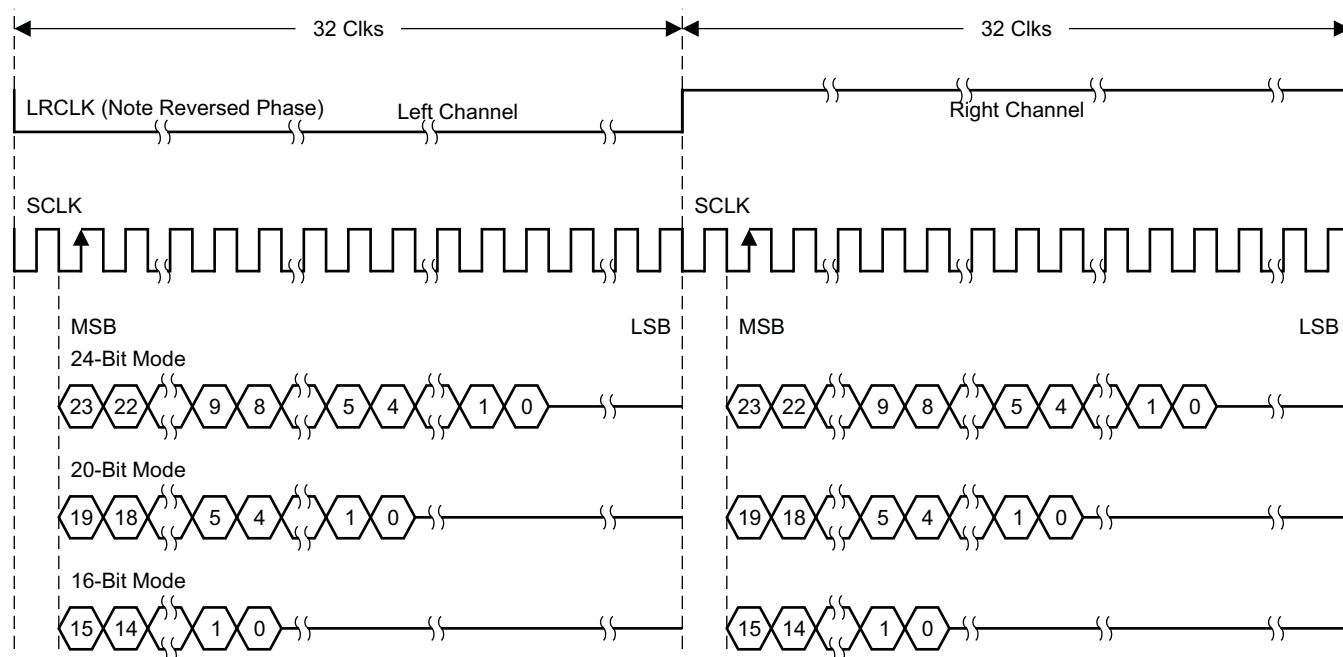

T0034-01

NOTE: All data presented in 2s-complement form with MSB first.

Figure 18. I<sup>2</sup>S 64-f<sub>s</sub> Format

2-Channel I<sup>2</sup>S (Philips Format) Stereo Input/Output (24-Bit Transfer Word Size)

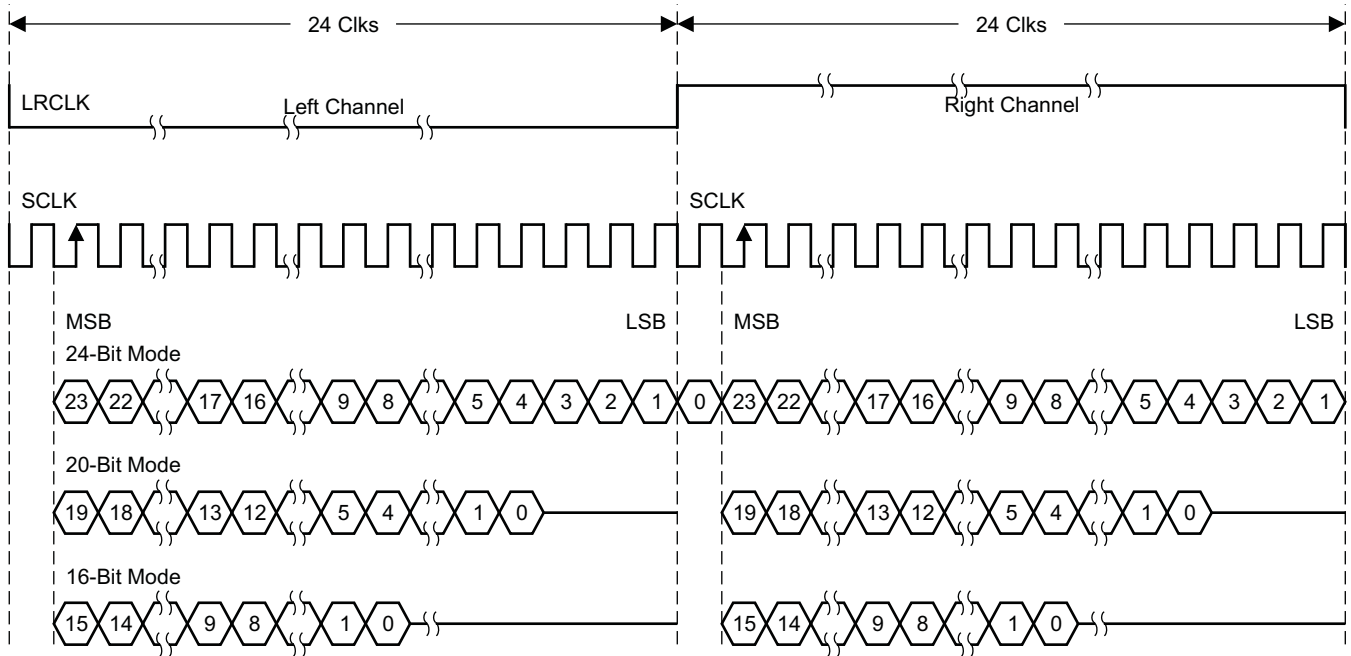

T0092-01

NOTE: All data presented in 2s-complement form with MSB first.

**Figure 19. I<sup>2</sup>S 48-f<sub>s</sub> Format**

2-Channel I<sup>2</sup>S (Philips Format) Stereo Input

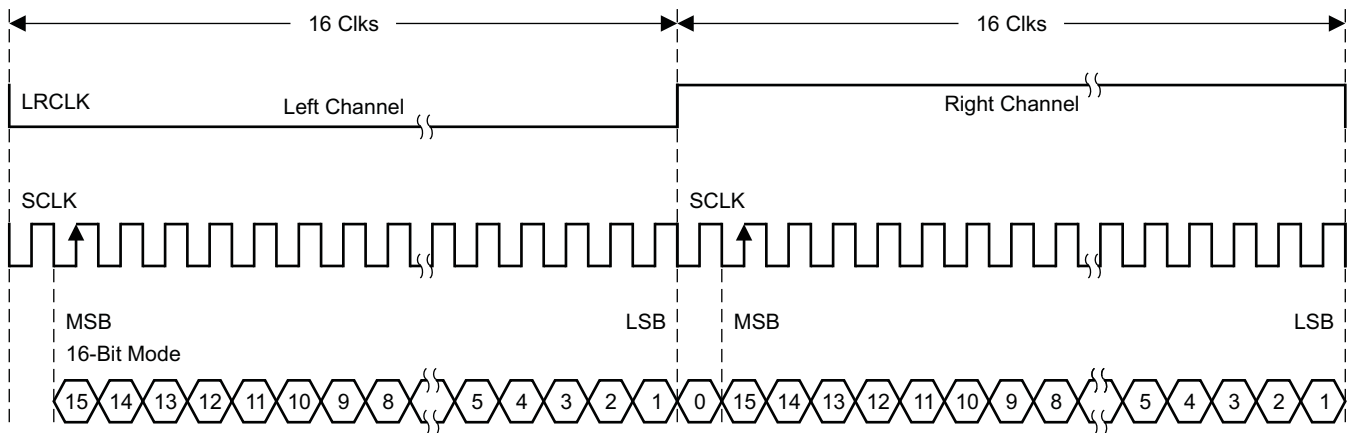

T0266-01

NOTE: All data presented in 2s-complement form with MSB first.

**Figure 20. I<sup>2</sup>S 32-f<sub>s</sub> Format**

**Left-Justified**

Left-justified (LJ) timing uses LRCLK to define when the data being transmitted is for the left channel and when it is for the right channel. LRCLK is high for the left channel and low for the right channel. A bit clock running at 32, 48, or 64 × f<sub>s</sub> is used to clock in the data. The first bit of data appears on the data lines at the same time LRCLK toggles. The data is written MSB-first and is valid on the rising edge of the bit clock. The DAP masks unused trailing data bit positions.

2-Channel Left-Justified Stereo Input

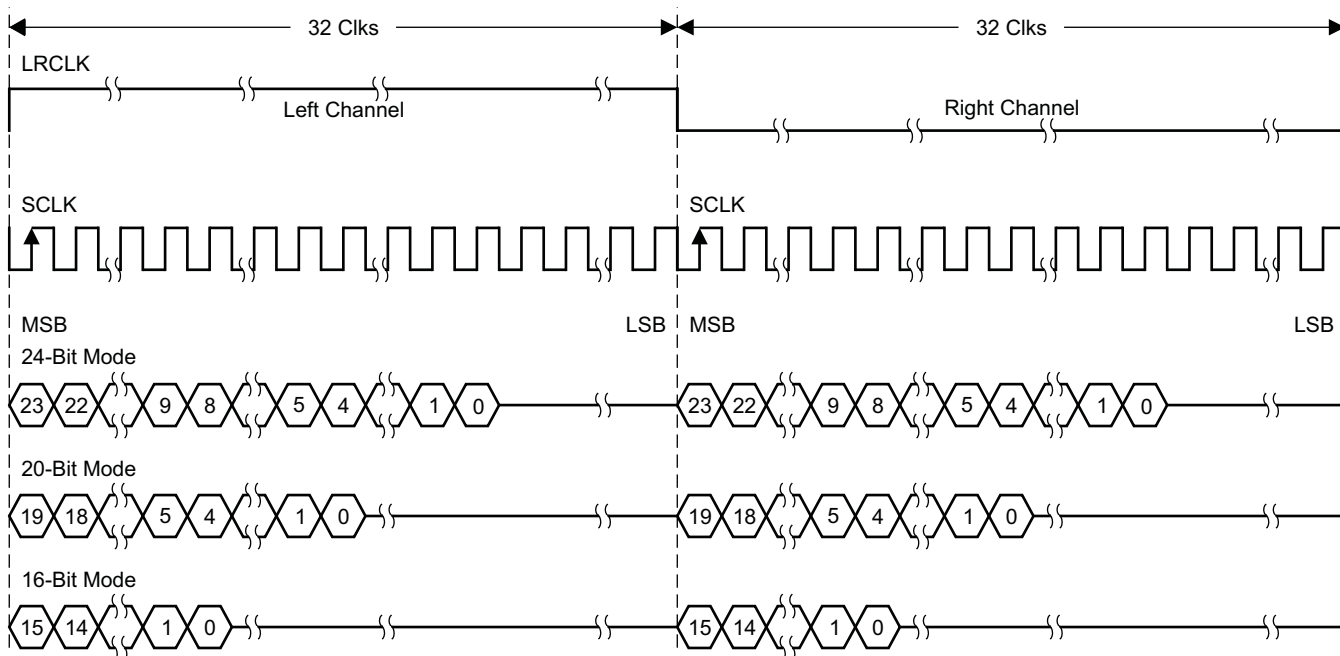

T0034-02

NOTE: All data presented in 2s-complement form with MSB first.

Figure 21. Left-Justified 64-f<sub>s</sub> Format

2-Channel Left-Justified Stereo Input (24-Bit Transfer Word Size)

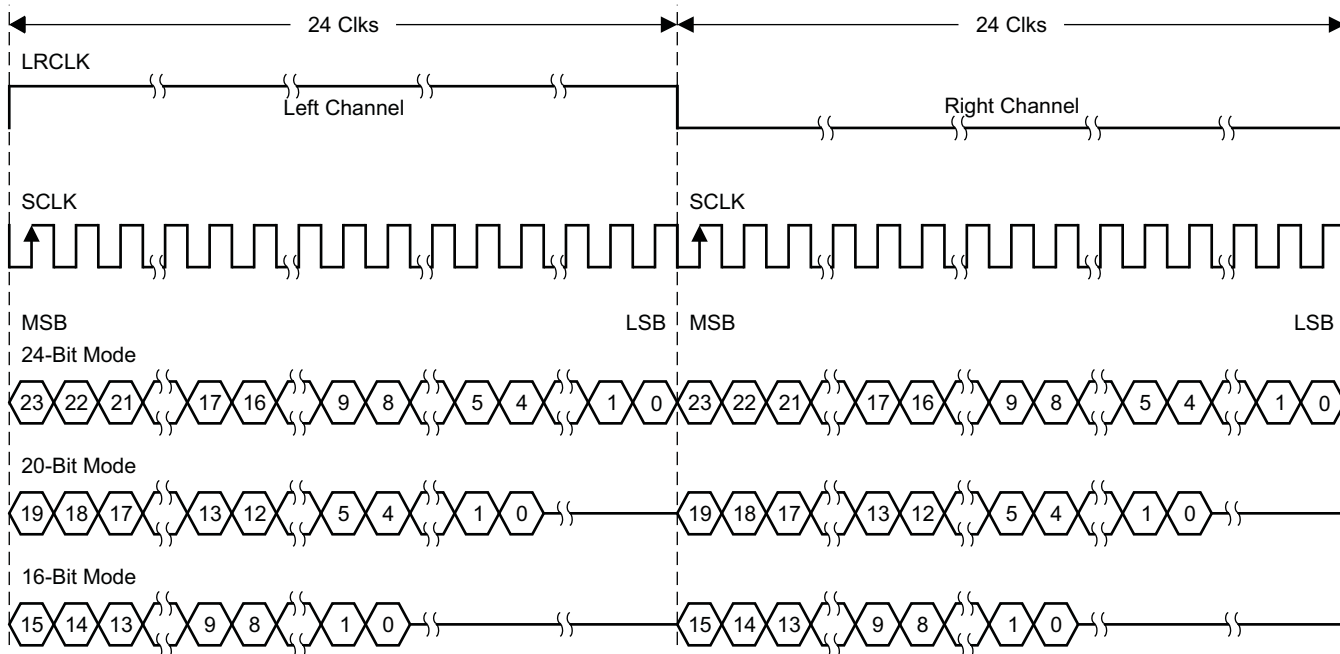

T0092-02

NOTE: All data presented in 2s-complement form with MSB first.

Figure 22. Left-Justified 48-f<sub>s</sub> Format

2-Channel Left-Justified Stereo Input

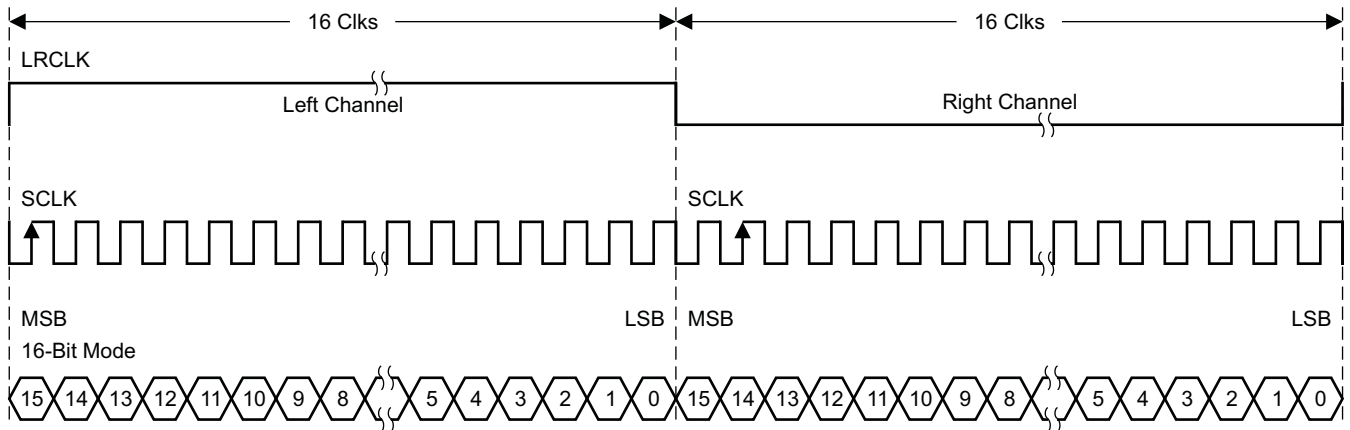

T0266-02

NOTE: All data presented in 2s-complement form with MSB first.

**Figure 23. Left-Justified 32- $f_s$  Format**

**Right-Justified**

Right-justified (RJ) timing uses LRCLK to define when the data being transmitted is for the left channel and when it is for the right channel. LRCLK is high for the left channel and low for the right channel. A bit clock running at  $32, 48, \text{ or } 64 \times f_s$  is used to clock in the data. The first bit of data appears on the data 8 bit-clock periods (for 24-bit data) after LRCLK toggles. In RJ mode, the LSB of data is always clocked by the last bit clock before LRCLK transitions. The data is written MSB-first and is valid on the rising edge of bit clock. The DAP masks unused leading data bit positions.

2-Channel Right-Justified (Sony Format) Stereo Input

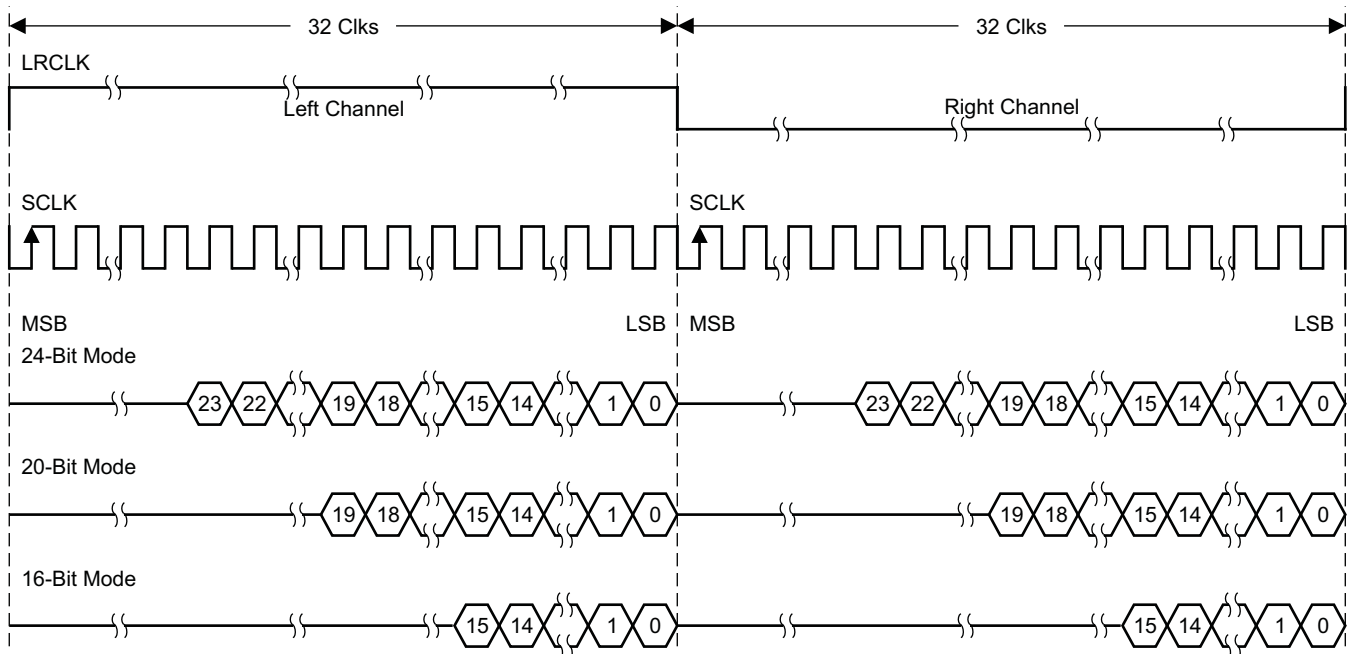

T0034-03

**Figure 24. Right-Justified 64- $f_s$  Format**

2-Channel Right-Justified Stereo Input (24-Bit Transfer Word Size)

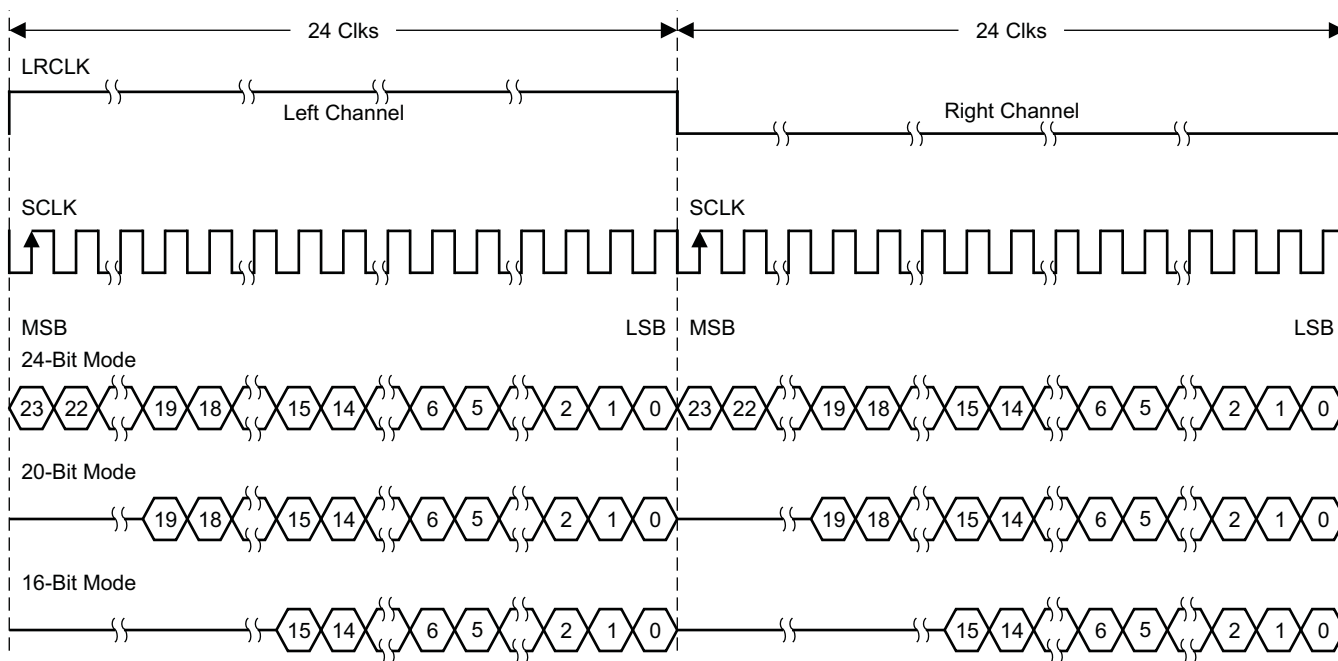

T0092-03

Figure 25. Right-Justified 48-f<sub>s</sub> Format

2-Channel Right-Justified (Sony Format) Stereo Input

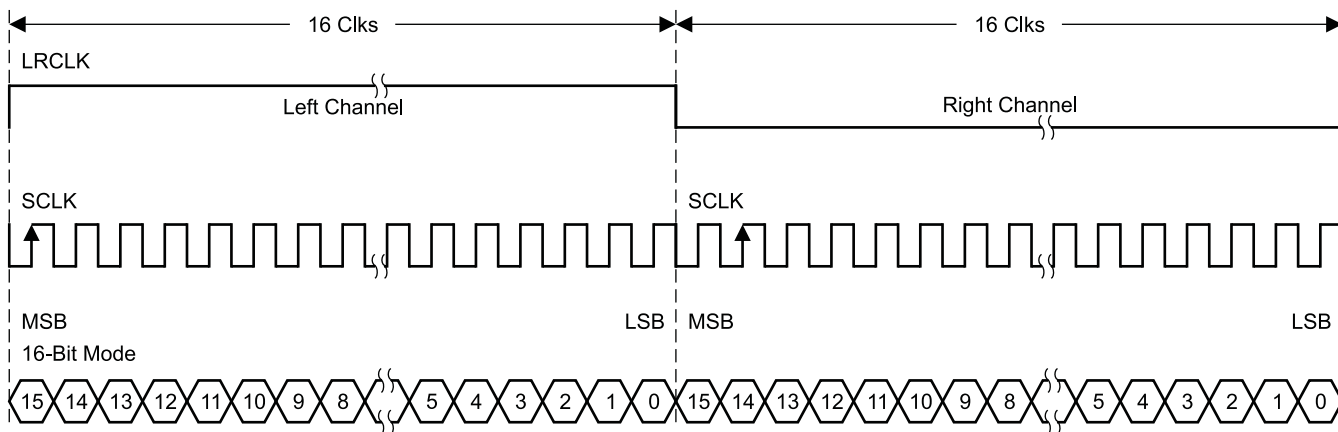

T0266-03

Figure 26. Right-Justified 32-f<sub>s</sub> Format

## I<sup>2</sup>C SERIAL CONTROL INTERFACE

The TAS5731 DAP has a bidirectional I<sup>2</sup>C interface that is compatible with the Inter IC (I<sup>2</sup>C) bus protocol and supports both 100-kHz and 400-kHz data transfer rates for single- and multiple-byte write and read operations. This is a slave-only device that does not support a multimaster bus environment or wait-state insertion. The control interface is used to program the registers of the device and to read device status.

The DAP supports the standard-mode I<sup>2</sup>C bus operation (100 kHz maximum) and the fast I<sup>2</sup>C bus operation (400 kHz maximum). The DAP performs all I<sup>2</sup>C operations without I<sup>2</sup>C wait cycles.

### General I<sup>2</sup>C Operation

The I<sup>2</sup>C bus employs two signals, SDA (data) and SCL (clock), to communicate between integrated circuits in a system. Data is transferred on the bus serially, one bit at a time. The address and data can be transferred in byte (8-bit) format, with the most-significant bit (MSB) transferred first. In addition, each byte transferred on the bus is acknowledged by the receiving device with an acknowledge bit. Each transfer operation begins with the master device driving a start condition on the bus and ends with the master device driving a stop condition on the bus. The bus uses transitions on the data pin (SDA) while the clock is high to indicate start and stop conditions. A high-to-low transition on SDA indicates a start and a low-to-high transition indicates a stop. Normal data-bit transitions must occur within the low time of the clock period. These conditions are shown in Figure 27. The master generates the 7-bit slave address and the read/write (R/W) bit to open communication with another device and then waits for an acknowledge condition. The TAS5731 holds SDA low during the acknowledge clock period to indicate an acknowledgment. When this occurs, the master transmits the next byte of the sequence. Each device is addressed by a unique 7-bit slave address plus R/W bit (1 byte). All compatible devices share the same signals via a bidirectional bus using a wired-AND connection. An external pullup resistor must be used for the SDA and SCL signals to set the high level for the bus.

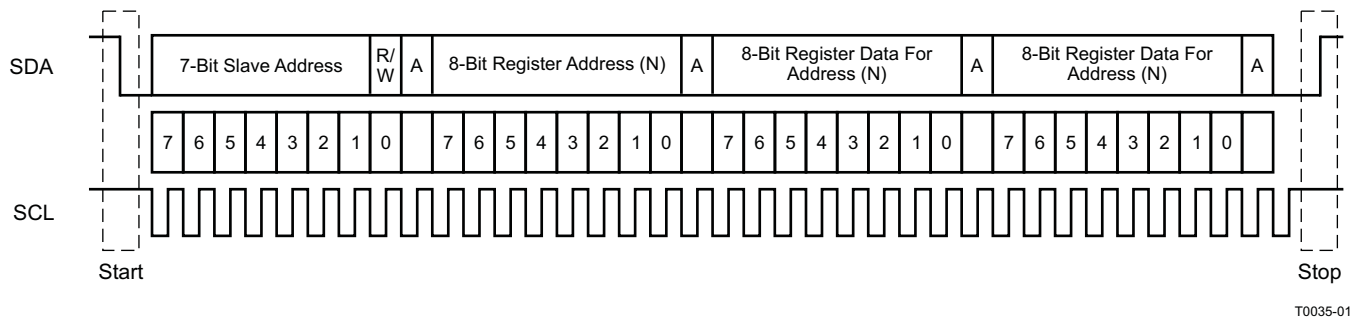

**Figure 27. Typical I<sup>2</sup>C Sequence**

There is no limit on the number of bytes that can be transmitted between start and stop conditions. When the last word transfers, the master generates a stop condition to release the bus. A generic data transfer sequence is shown in Figure 27.

The 7-bit address for TAS5731 is 0011 011 (0x36).

### Single- and Multiple-Byte Transfers

The serial control interface supports both single-byte and multiple-byte read/write operations for subaddresses 0x00 to 0x1F. However, for the subaddresses 0x20 to 0xFF, the serial control interface supports only multiple-byte read/write operations (in multiples of 4 bytes).

During multiple-byte read operations, the DAP responds with data, a byte at a time, starting at the subaddress assigned, as long as the master device continues to respond with acknowledges. If a particular subaddress does not contain 32 bits, the unused bits are read as logic 0.

During multiple-byte write operations, the DAP compares the number of bytes transmitted to the number of bytes that are required for each specific subaddress. For example, if a write command is received for a biquad subaddress, the DAP must receive five 32-bit words. If fewer than five 32-bit data words have been received when a stop command (or another start command) is received, the received data is discarded.

Supplying a subaddress for each subaddress transaction is referred to as random I<sup>2</sup>C addressing. The TAS5731 also supports sequential I<sup>2</sup>C addressing. For write transactions, if a subaddress is issued followed by data for that subaddress and the 15 subaddresses that follow, a sequential I<sup>2</sup>C write transaction has taken place, and the data for all 16 subaddresses is successfully received by the TAS5731. For I<sup>2</sup>C sequential-write transactions, the subaddress then serves as the start address, and the amount of data subsequently transmitted, before a stop or start is transmitted, determines how many subaddresses are written. As was true for random addressing, sequential addressing requires that a complete set of data be transmitted. If only a partial set of data is written to the last subaddress, the data for the last subaddress is discarded. However, all other data written is accepted; only the incomplete data is discarded.

### Single-Byte Write

As shown in Figure 28, a single-byte data-write transfer begins with the master device transmitting a start condition followed by the I<sup>2</sup>C device address and the read/write bit. The read/write bit determines the direction of the data transfer. For a data-write transfer, the read/write bit is a 0. After receiving the correct I<sup>2</sup>C device address and the read/write bit, the DAP responds with an acknowledge bit. Next, the master transmits the address byte or bytes corresponding to the TAS5731 internal memory address being accessed. After receiving the address byte, the TAS5731 again responds with an acknowledge bit. Next, the master device transmits the data byte to be written to the memory address being accessed. After receiving the data byte, the TAS5731 again responds with an acknowledge bit. Finally, the master device transmits a stop condition to complete the single-byte data-write transfer.

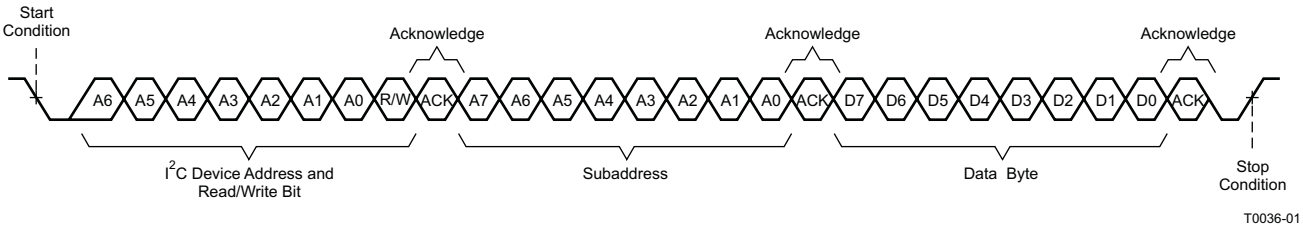

Figure 28. Single-Byte Write Transfer

### Multiple-Byte Write

A multiple-byte data-write transfer is identical to a single-byte data-write transfer except that multiple data bytes are transmitted by the master device to the DAP as shown in Figure 29. After receiving each data byte, the TAS5731 responds with an acknowledge bit.

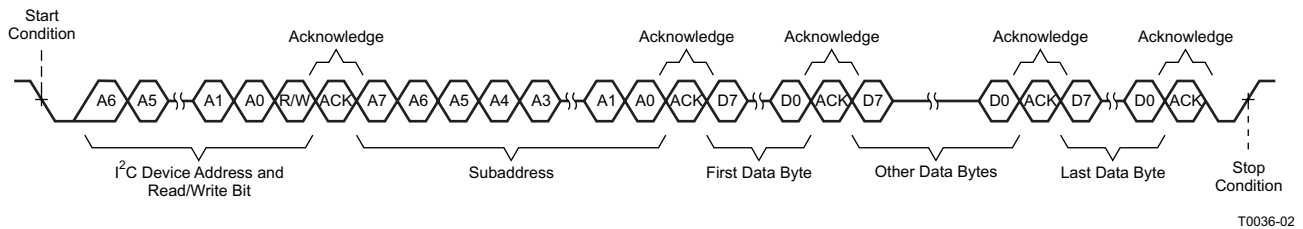
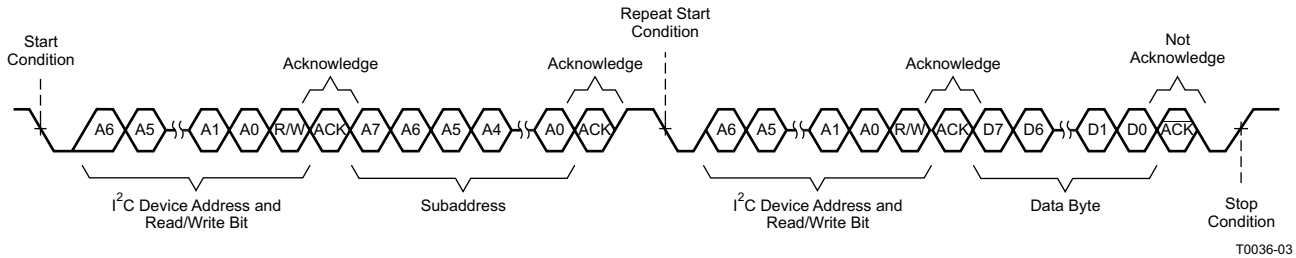

Figure 29. Multiple-Byte Write Transfer

### Single-Byte Read

As shown in [Figure 30](#), a single-byte data-read transfer begins with the master device transmitting a start condition, followed by the I<sup>2</sup>C device address and the read/write bit. For the data read transfer, both a write followed by a read are actually done. Initially, a write is done to transfer the address byte or bytes of the internal memory address to be read. As a result, the read/write bit becomes a 0. After receiving the TAS5731 address and the read/write bit, TAS5731 responds with an acknowledge bit. In addition, after sending the internal memory address byte or bytes, the master device transmits another start condition followed by the TAS5731 address and the read/write bit again. This time, the read/write bit becomes a 1, indicating a read transfer. After receiving the address and the read/write bit, the TAS5731 again responds with an acknowledge bit. Next, the TAS5731 transmits the data byte from the memory address being read. After receiving the data byte, the master device transmits a not-acknowledge followed by a stop condition to complete the single-byte data-read transfer.



**Figure 30. Single-Byte Read Transfer**

### Multiple-Byte Read

A multiple-byte data-read transfer is identical to a single-byte data-read transfer except that multiple data bytes are transmitted by the TAS5731 to the master device as shown in [Figure 31](#). Except for the last data byte, the master device responds with an acknowledge bit after receiving each data byte.

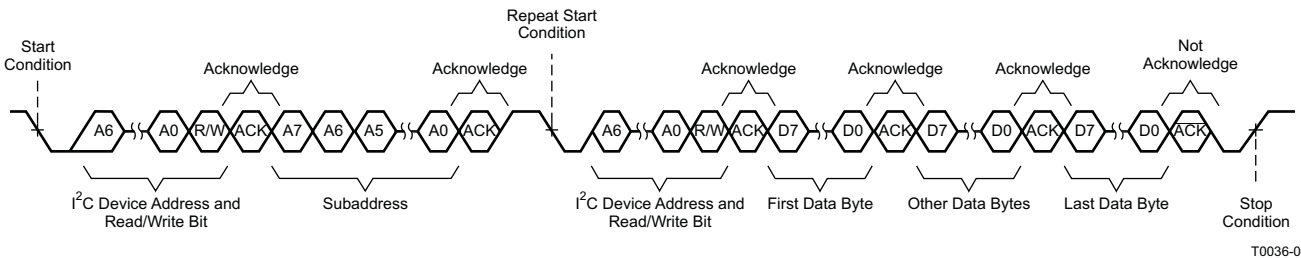
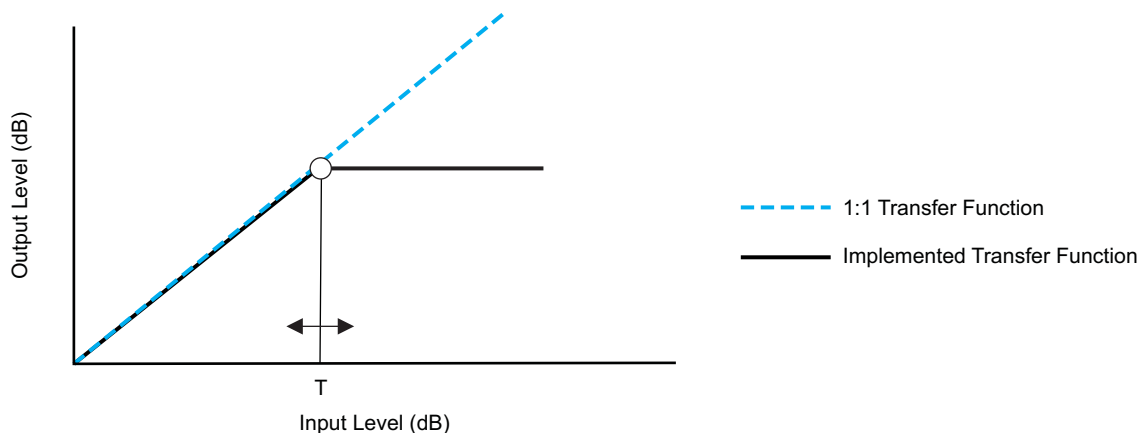

**Figure 31. Multiple-Byte Read Transfer**

### Dynamic Range Control (DRC)

The DRC scheme has two DRC blocks. There is one ganged DRC for the high-band left/right channels and one DRC for the low-band left/right channels.

The DRC input/output diagram is shown in Figure 32.



M0091-04

Professional-quality dynamic range compression automatically adjusts volume to flatten volume level.

- Each DRC has adjustable threshold levels.
- Programmable attack and decay time constants
- *Transparent compression*: compressors can attack fast enough to avoid apparent clipping before engaging, and decay times can be set slow enough to avoid pumping.

Figure 32. Dynamic Range Control

	$\alpha, \omega$	T	$\alpha_a, \omega_a / \alpha_d, \omega_d$
DRC1	0x3C	0x3B	0x40
DRC2	0x3F	0x3E	0x43

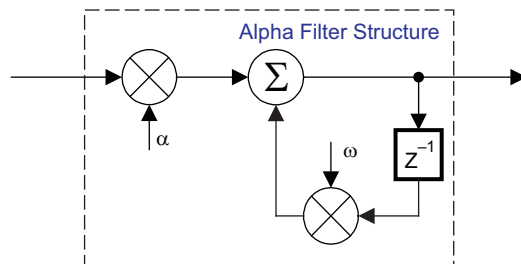

B0265-04

T = 9.23 format, all other DRC coefficients are 3.23 format

Figure 33. DRC Structure

## PWM LEVEL METER

### 26-Bit 3.23 Number Format

All mixer gain coefficients are 26-bit coefficients using a 3.23 number format. Numbers formatted as 3.23 numbers means that there are 3 bits to the left of the binary point and 23 bits to the right of the binary point. This is shown in [Figure 34](#).

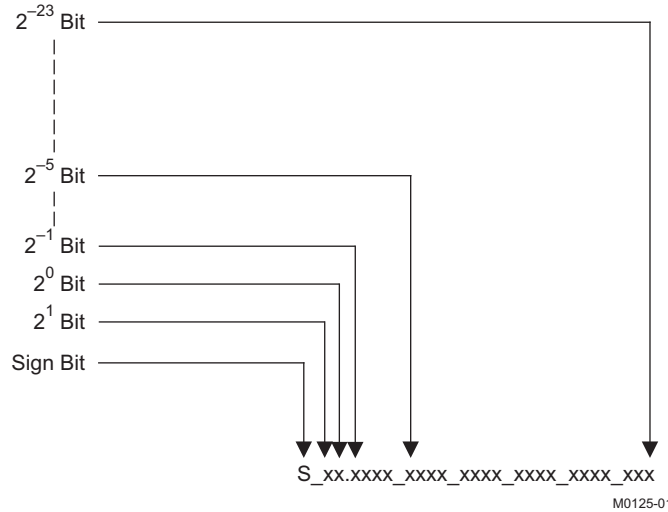

**Figure 34. 3.23 Format**

The decimal value of a 3.23 format number can be found by following the weighting shown in [Figure 34](#). If the most significant bit is logic 0, the number is a positive number, and the weighting shown yields the correct number. If the most significant bit is a logic 1, then the number is a negative number. In this case every bit must be inverted, a 1 added to the result, and then the weighting shown in [Figure 35](#) applied to obtain the magnitude of the negative number.

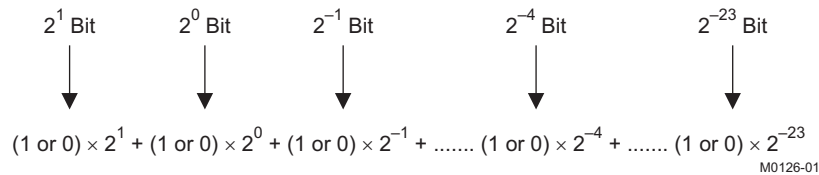

**Figure 35. Conversion Weighting Factors—3.23 Format to Floating Point**

Gain coefficients, entered via the I<sup>2</sup>C bus, must be entered as 32-bit binary numbers. The format of the 32-bit number (4-byte or 8-digit hexadecimal number) is shown in [Figure 36](#).

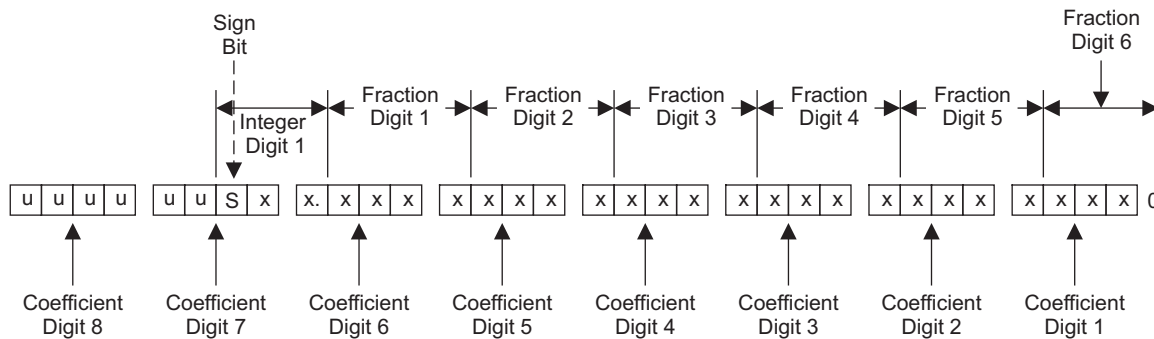

u = unused or don't care bits  
Digit = hexadecimal digit

M0127-01

Figure 36. Alignment of 3.23 Coefficient in 32-Bit I²C Word

Table 1. Sample Calculation for 3.23 Format

db	Linear	Decimal	Hex (3.23 Format)
0	1	8,388,608	80 0000
5	1.77	14,917,288	00E3 9EA8
-5	0.56	4,717,260	0047 FACC
X	$L = 10^{(X/20)}$	$D = 8,388,608 \times L$	$H = \text{dec2hex}(D, 8)$

Table 2. Sample Calculation for 9.17 Format

db	Linear	Decimal	Hex (9.17 Format)
0	1	131,072	2 0000
5	1.77	231,997	3 8A3D
-5	0.56	73,400	1 1EB8
X	$L = 10^{(X/20)}$	$D = 131,072 \times L$	$H = \text{dec2hex}(D, 8)$

Recommended Use Model

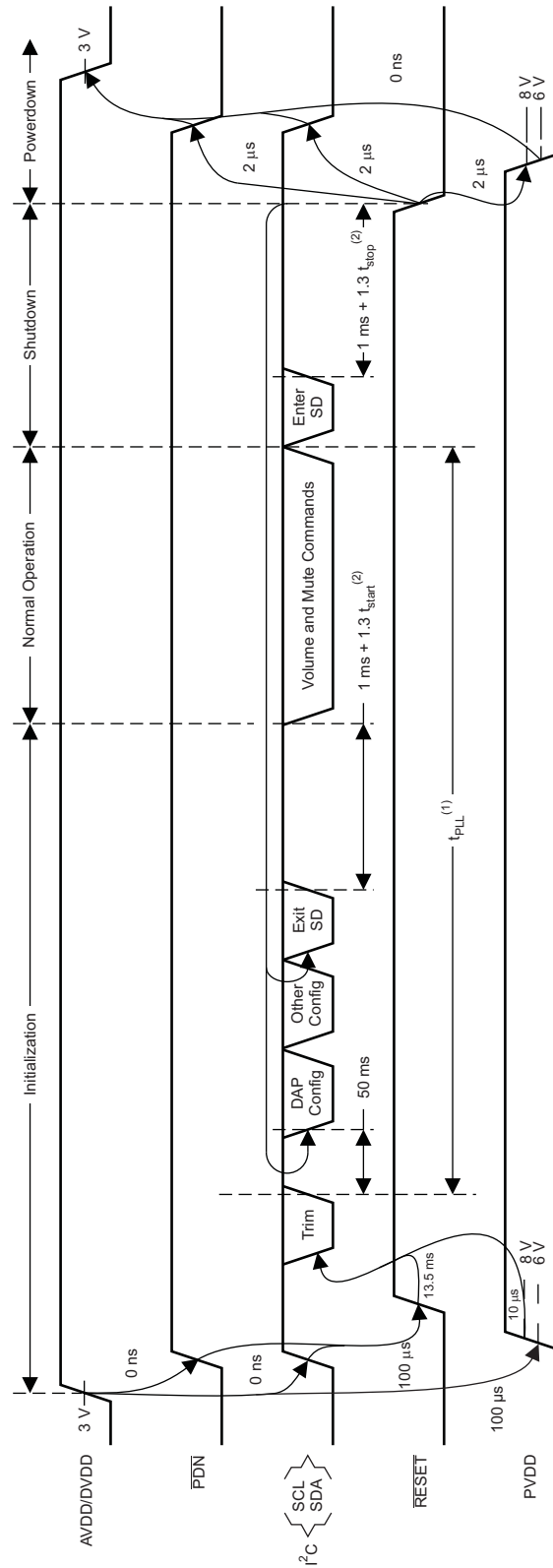

(1)  $t_{PLL}$  has to be greater than  $240 \text{ ms} + 1.3 t_{start}$ .  
 This constraint only applies to the first trim command following AVDD/DVDD power-up.  
 It does not apply to trim commands following subsequent resets.  
 (2)  $t_{start}/t_{stop}$  = PWM start/stop time as defined in register 0X1A

T0419-06

Figure 37. Recommended Command Sequence

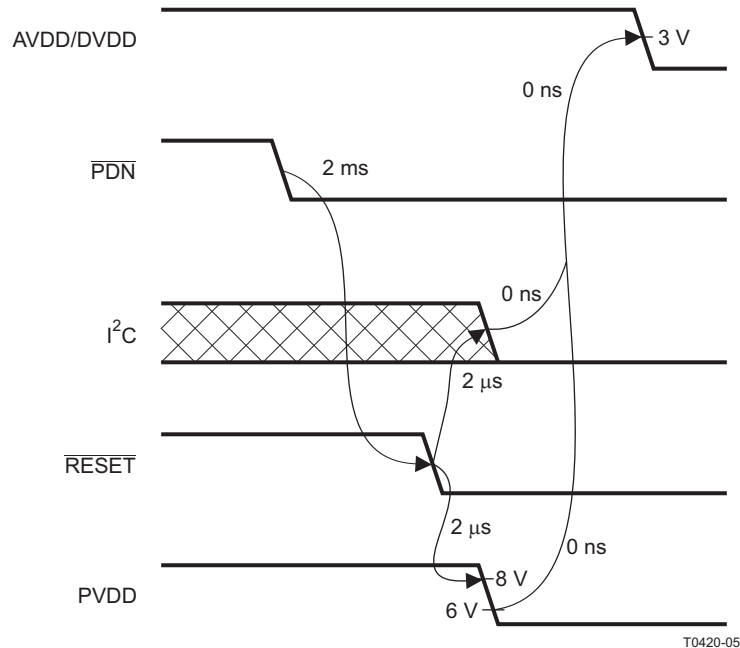

**Figure 38. Power-Loss Sequence**

### Initialization Sequence

Use the following sequence to power up and initialize the device:

1. Hold all digital inputs low and ramp up AVDD/DVDD to at least 3 V.
2. Initialize digital inputs and PVDD supply as follows:
  - Drive  $\overline{\text{RESET}} = 0$ ,  $\overline{\text{PDN}} = 1$ , and other digital inputs to their desired state while ensuring that all are never more than 2.5 V above AVDD/DVDD. Wait at least 100 μs, drive  $\overline{\text{RESET}} = 1$ , and wait at least another 13.5 ms.
  - Ramp up PVDD to at least 8 V while ensuring that it remains below 6 V for at least 100 μs after AVDD/DVDD reaches 3 V. Then wait at least another 10 μs.
3. Trim oscillator (write 0x00 to register 0x1B) and wait at least 50 ms.
4. Configure the DAP via I<sup>2</sup>C (see User's Guide for typical values).
5. Configure remaining registers.
6. Exit shutdown (sequence defined below).

### Normal Operation

The following are the only events supported during normal operation:

1. Writes to master/channel volume registers
2. Writes to soft-mute register
3. Enter and exit shutdown (sequence defined below)

**Note:** Event 3 is not supported for 240 ms + 1.3 × t<sub>start</sub> after trim following AVDD/DVDD power-up ramp (where t<sub>start</sub> is specified by register 0x1A).

### Shutdown Sequence

Enter:

1. Write 0x40 to register 0x05.
2. Wait at least  $1 \text{ ms} + 1.3 \times t_{\text{stop}}$  (where  $t_{\text{stop}}$  is specified by register 0x1A).
3. If desired, reconfigure by returning to step 4 of initialization sequence.

Exit:

1. Write 0x00 to register 0x05 (exit shutdown command may not be serviced for as much as 240 ms after trim following AVDD/DVDD power-up ramp).
2. Wait at least  $1 \text{ ms} + 1.3 \times t_{\text{start}}$  (where  $t_{\text{start}}$  is specified by register 0x1A).
3. Proceed with normal operation.

### Power-Down Sequence

Use the following sequence to power down the device and its supplies:

1. If time permits, enter shutdown (sequence defined above); else, in case of sudden power loss, assert  $\overline{\text{PDN}} = 0$  and wait at least 2 ms.
2. Assert  $\overline{\text{RESET}} = 0$ .
3. Drive digital inputs low and ramp down PVDD supply as follows:
  - Drive all digital inputs low after  $\overline{\text{RESET}}$  has been low for at least 2  $\mu\text{s}$ .
  - Ramp down PVDD while ensuring that it remains above 8 V until  $\overline{\text{RESET}}$  has been low for at least 2  $\mu\text{s}$ .
4. Ramp down AVDD/DVDD while ensuring that it remains above 3 V until PVDD is below 6 V and that it is never more than 2.5 V below the digital inputs.

**Table 3. Serial Control Interface Register Summary**

SUBADDRESS	REGISTER NAME	NO. OF BYTES	CONTENTS	INITIALIZATION VALUE
			A u indicates unused bits.	
0x00	Clock control register	1	Description shown in subsequent section	0x6C
0x01	Device ID register	1	Description shown in subsequent section	0x00
0x02	Error status register	1	Description shown in subsequent section	0x00
0x03	System control register 1	1	Description shown in subsequent section	0xA0
0x04	Serial data interface register	1	Description shown in subsequent section	0x05
0x05	System control register 2	1	Description shown in subsequent section	0x40
0x06	Soft mute register	1	Description shown in subsequent section	0x00
0x07	Master volume	1	Description shown in subsequent section	0xFF (mute)
0x08	Channel 1 vol	1	Description shown in subsequent section	0x30 (0 dB)
0x09	Channel 2 vol	1	Description shown in subsequent section	0x30 (0 dB)
0x0A	Channel 3 vol	1	Description shown in subsequent section	0x30 (0 dB)
0x0B–0x0D		1	Reserved <sup>(1)</sup>	
0x0E	Volume configuration register	1	Description shown in subsequent section	0x91
0x0F		1	Reserved <sup>(1)</sup>	
0x10	Modulation limit register	1	Description shown in subsequent section	0x02
0x11	IC delay channel 1	1	Description shown in subsequent section	0xAC
0x12	IC delay channel 2	1	Description shown in subsequent section	0x54
0x13	IC delay channel 3	1	Description shown in subsequent section	0xAC
0x14	IC delay channel 4	1	Description shown in subsequent section	0x54
0x15–0x18		1	Reserved <sup>(1)</sup>	
0x19	PWM channel shutdown group register	1	Description shown in subsequent section	0x30
0x1A	Start/stop period register	1		0x0F
0x1B	Oscillator trim register	1		0x82
0x1C	BKND_ERR register	1		0x02
0x1D–0x1F		1	Reserved <sup>(1)</sup>	
0x20	Input MUX register	4	Description shown in subsequent section	0x0001 7772
0x21	Ch 4 source select register	4	Description shown in subsequent section	0x0000 4303
0x22–0x24		4	Reserved <sup>(1)</sup>	
0x25	PWM MUX register	4	Description shown in subsequent section	0x0102 1345
0x26–0x28		4	Reserved <sup>(1)</sup>	
0x29	ch1_bq[0]	20	u[31:26], b0[25:0]	0x0080 0000
			u[31:26], b1[25:0]	0x0000 0000
			u[31:26], b2[25:0]	0x0000 0000
			u[31:26], a1[25:0]	0x0000 0000
			u[31:26], a2[25:0]	0x0000 0000
0x2A	ch1_bq[1]	20	u[31:26], b0[25:0]	0x0080 0000
			u[31:26], b1[25:0]	0x0000 0000
			u[31:26], b2[25:0]	0x0000 0000
			u[31:26], a1[25:0]	0x0000 0000
			u[31:26], a2[25:0]	0x0000 0000

(1) Reserved registers should not be accessed.

**Table 3. Serial Control Interface Register Summary (continued)**

SUBADDRESS	REGISTER NAME	NO. OF BYTES	CONTENTS	INITIALIZATION VALUE
0x2B	ch1_bq[2]	20	u[31:26], b0[25:0]	0x0080 0000
			u[31:26], b1[25:0]	0x0000 0000
			u[31:26], b2[25:0]	0x0000 0000
			u[31:26], a1[25:0]	0x0000 0000
			u[31:26], a2[25:0]	0x0000 0000
0x2C	ch1_bq[3]	20	u[31:26], b0[25:0]	0x0080 0000
			u[31:26], b1[25:0]	0x0000 0000
			u[31:26], b2[25:0]	0x0000 0000
			u[31:26], a1[25:0]	0x0000 0000
			u[31:26], a2[25:0]	0x0000 0000
0x2D	ch1_bq[4]	20	u[31:26], b0[25:0]	0x0080 0000
			u[31:26], b1[25:0]	0x0000 0000
			u[31:26], b2[25:0]	0x0000 0000
			u[31:26], a1[25:0]	0x0000 0000
			u[31:26], a2[25:0]	0x0000 0000
0x2E	ch1_bq[5]	20	u[31:26], b0[25:0]	0x0080 0000
			u[31:26], b1[25:0]	0x0000 0000
			u[31:26], b2[25:0]	0x0000 0000
			u[31:26], a1[25:0]	0x0000 0000
			u[31:26], a2[25:0]	0x0000 0000
0x2F	ch1_bq[6]	20	u[31:26], b0[25:0]	0x0080 0000
			u[31:26], b1[25:0]	0x0000 0000
			u[31:26], b2[25:0]	0x0000 0000
			u[31:26], a1[25:0]	0x0000 0000
			u[31:26], a2[25:0]	0x0000 0000
0x30	ch2_bq[0]	20	u[31:26], b0[25:0]	0x0080 0000
			u[31:26], b1[25:0]	0x0000 0000
			u[31:26], b2[25:0]	0x0000 0000
			u[31:26], a1[25:0]	0x0000 0000
			u[31:26], a2[25:0]	0x0000 0000
0x31	ch2_bq[1]	20	u[31:26], b0[25:0]	0x0080 0000
			u[31:26], b1[25:0]	0x0000 0000
			u[31:26], b2[25:0]	0x0000 0000
			u[31:26], a1[25:0]	0x0000 0000
			u[31:26], a2[25:0]	0x0000 0000
0x32	ch2_bq[2]	20	u[31:26], b0[25:0]	0x0080 0000
			u[31:26], b1[25:0]	0x0000 0000
			u[31:26], b2[25:0]	0x0000 0000
			u[31:26], a1[25:0]	0x0000 0000
			u[31:26], a2[25:0]	0x0000 0000
0x33	ch2_bq[3]	20	u[31:26], b0[25:0]	0x0080 0000
			u[31:26], b1[25:0]	0x0000 0000
			u[31:26], b2[25:0]	0x0000 0000
			u[31:26], a1[25:0]	0x0000 0000
			u[31:26], a2[25:0]	0x0000 0000

**Table 3. Serial Control Interface Register Summary (continued)**

SUBADDRESS	REGISTER NAME	NO. OF BYTES	CONTENTS	INITIALIZATION VALUE
0x34	ch2_bq[4]	20	u[31:26], b0[25:0]	0x0080 0000
			u[31:26], b1[25:0]	0x0000 0000
			u[31:26], b2[25:0]	0x0000 0000
			u[31:26], a1[25:0]	0x0000 0000
			u[31:26], a2[25:0]	0x0000 0000
0x35	ch2_bq[5]	20	u[31:26], b0[25:0]	0x0080 0000
			u[31:26], b1[25:0]	0x0000 0000
			u[31:26], b2[25:0]	0x0000 0000
			u[31:26], a1[25:0]	0x0000 0000
			u[31:26], a2[25:0]	0x0000 0000
0x36	ch2_bq[6]	20	u[31:26], b0[25:0]	0x0080 0000
			u[31:26], b1[25:0]	0x0000 0000
			u[31:26], b2[25:0]	0x0000 0000
			u[31:26], a1[25:0]	0x0000 0000
			u[31:26], a2[25:0]	0x0000 0000
0x37 - 0x39		4	Reserved <sup>(2)</sup>	
0x3A	DRC1 ae <sup>(3)</sup>	8	u[31:26], ae[25:0]	0x0080 0000
	DRC1 (1 – ae)		u[31:26], (1 – ae)[25:0]	0x0000 0000
0x3B	DRC1 aa	8	u[31:26], aa[25:0]	0x0080 0000
	DRC1 (1 – aa)		u[31:26], (1 – aa)[25:0]	0x0000 0000
0x3C	DRC1 ad	8	u[31:26], ad[25:0]	0x0080 0000
	DRC1 (1 – ad)		u[31:26], (1 – ad)[25:0]	0x0000 0000
0x3D	DRC2 ae	8	u[31:26], ae[25:0]	0x0080 0000
	DRC 2 (1 – ae)		u[31:26], (1 – ae)[25:0]	0x0000 0000
0x3E	DRC2 aa	8	u[31:26], aa[25:0]	0x0080 0000
	DRC2 (1 – aa)		u[31:26], (1 – aa)[25:0]	0x0000 0000
0x3F	DRC2 ad	8	u[31:26], ad[25:0]	0x0080 0000
	DRC2 (1 – ad)		u[31:26], (1 – ad)[25:0]	0x0000 0000
0x40	DRC1-T	4	T1[31:0] (9.23 format)	0xFDA2 1490
0x41	DRC1-K	4	u[31:26], K1[25:0]	0x0384 2109
0x42	DRC1-O	4	u[31:26], O1[25:0]	0x0008 4210
0x43	DRC2-T	4	T2[31:0] (9.23 format)	0xFDA2 1490
0x44	DRC2-K	4	u[31:26], K2[25:0]	0x0384 2109
0x45	DRC2-O	4	u[31:26], O2[25:0]	0x0008 4210
0x46	DRC control	4	Description shown in subsequent section	0x0000 0000
0x47–0x4F		4	Reserved <sup>(2)</sup>	
0x50	Bank switch control	4	Description shown in subsequent section	0x0F70 8000
0x51	Ch 1 output mixer	12	Ch 1 output mix1[2]	0x0080 0000
			Ch 1 output mix1[1]	0x0000 0000
			Ch 1 output mix1[0]	0x0000 0000
0x52	Ch 2 output mixer	12	Ch 2 output mix2[2]	0x0080 0000
			Ch 2 output mix2[1]	0x0000 0000
			Ch 2 output mix2[0]	0x0000 0000

(2) Reserved registers should not be accessed.

(3) "ae" stands for  $\alpha$  of energy filter, "aa" stands for  $\alpha$  of attack filter and "ad" stands for  $\alpha$  of decay filter and  $1 - \alpha = \omega$ .

**Table 3. Serial Control Interface Register Summary (continued)**

SUBADDRESS	REGISTER NAME	NO. OF BYTES	CONTENTS	INITIALIZATION VALUE
0x53	Ch 1 input mixer	16	Ch 1 input mixer[3]	0x0080 0000
			Ch 1 input mixer[2]	0x0000 0000
			Ch 1 input mixer[1]	0x0000 0000
			Ch 1 input mixer[0]	0x0080 0000
0x54	Ch 2 input mixer	16	Ch 2 input mixer[3]	0x0080 0000
			Ch 2 input mixer[2]	0x0000 0000
			Ch 2 input mixer[1]	0x0000 0000
			Ch 2 input mixer[0]	0x0080 0000
0x55	Channel 3 input mixer	12	Channel 3 input mixer [2]	0x0080 0000
			Channel 3 input mixer [1]	0x0000 0000
			Channel 3 input mixer [0]	0x0000 0000
0x56	Output post-scale	4	u[31:26], post[25:0]	0x0080 0000
0x57	Output pre-scale	4	u[31:26], pre[25:0] (9.17 format)	0x0002 0000
0x58	ch1 BQ[7]	20	u[31:26], b0[25:0]	0x0080 0000
			u[31:26], b1[25:0]	0x0000 0000
			u[31:26], b2[25:0]	0x0000 0000
			u[31:26], a1[25:0]	0x0000 0000
			u[31:26], a2[25:0]	0x0000 0000
0x59	ch1 BQ[8]	20	u[31:26], b0[25:0]	0x0080 0000
			u[31:26], b1[25:0]	0x0000 0000
			u[31:26], b2[25:0]	0x0000 0000
			u[31:26], a1[25:0]	0x0000 0000
			u[31:26], a2[25:0]	0x0000 0000
0x5A	Subchannel BQ[0]	20	u[31:26], b0[25:0]	0x0080 0000
			u[31:26], b1[25:0]	0x0000 0000
			u[31:26], b2[25:0]	0x0000 0000
			u[31:26], a1[25:0]	0x0000 0000
			u[31:26], a2[25:0]	0x0000 0000
0x5B	Subchannel BQ[1]	20	u[31:26], b0[25:0]	0x0080 0000
			u[31:26], b1[25:0]	0x0000 0000
			u[31:26], b2[25:0]	0x0000 0000
			u[31:26], a1[25:0]	0x0000 0000
			u[31:26], a2[25:0]	0x0000 0000
0x5C	ch2 BQ[7]	20	u[31:26], b0[25:0]	0x0080 0000
			u[31:26], b1[25:0]	0x0000 0000
			u[31:26], b2[25:0]	0x0000 0000
			u[31:26], a1[25:0]	0x0000 0000
			u[31:26], a2[25:0]	0x0000 0000
0x5D	ch2 BQ[8]	20	u[31:26], b0[25:0]	0x0080 0000
			u[31:26], b1[25:0]	0x0000 0000
			u[31:26], b2[25:0]	0x0000 0000
			u[31:26], a1[25:0]	0x0000 0000
			u[31:26], a2[25:0]	0x0000 0000

**Table 3. Serial Control Interface Register Summary (continued)**

SUBADDRESS	REGISTER NAME	NO. OF BYTES	CONTENTS	INITIALIZATION VALUE
0x5E	pseudo_ch2 BQ[0]	20	u[31:26], b0[25:0]	0x0080 0000
			u[31:26], b1[25:0]	0x0000 0000
			u[31:26], b2[25:0]	0x0000 0000
			u[31:26], a1[25:0]	0x0000 0000
			u[31:26], a2[25:0]	0x0000 0000
0x5F		4	Reserved <sup>(4)</sup>	
0x60	Channel 4 (subchannel) output mixer	8	Ch 4 output mixer[1]	0x0000 0000
			Ch 4 output mixer[0]	0x0080 0000
0x61	Channel 4 (subchannel) input mixer	8	Ch 4 input mixer[1]	0x0040 0000
			Ch 4 input mixer[0]	0x0040 0000
0x62	IDF post scale	4	Post-IDF attenuation register	0x0000 0080
0x63–0xF7			Reserved <sup>(4)</sup>	0x0000 0000
0xF8	Device address enable register	4	Write F9 A5 A5 A5 in this register to enable write to device address update (0xF9)	0x0000 0000
0xF9	Device address Update Register	4	u[31:8], New Dev Id[7:1] , ZERO[0] (New Dev Id (7:1) defines the new device address	0X0000 0036
0xFA–0xFF		4	Reserved <sup>(4)</sup>	0x0000 0000

(4) Reserved registers should not be accessed.

All DAP coefficients are 3.23 format unless specified otherwise.

## CLOCK CONTROL REGISTER (0x00)

The clocks and data rates are automatically determined by the TAS5731. The clock control register contains the auto-detected clock status. Bits D7–D5 reflect the sample rate. Bits D4–D2 reflect the MCLK frequency. The device accepts a  $64 f_S$  or  $32 f_S$  SCLK rate for all MCLK ratios, but accepts a  $48 f_S$  SCLK rate for MCLK ratios of  $192 f_S$  and  $384 f_S$  only.

**Table 4. Clock Control Register (0x00)**

D7	D6	D5	D4	D3	D2	D1	D0	FUNCTION
0	0	0	–	–	–	–	–	$f_S = 32\text{-kHz}$ sample rate
0	0	1	–	–	–	–	–	Reserved <sup>(1)</sup>
0	1	0	–	–	–	–	–	Reserved <sup>(1)</sup>
<b>0</b>	<b>1</b>	<b>1</b>	–	–	–	–	–	<b><math>f_S = 44.1/48\text{-kHz}</math> sample rate</b> <sup>(2)</sup>
1	0	0	–	–	–	–	–	$f_S = 16\text{-kHz}$ sample rate
1	0	1	–	–	–	–	–	$f_S = 22.05/24\text{-kHz}$ sample rate
1	1	0	–	–	–	–	–	$f_S = 8\text{-kHz}$ sample rate
1	1	1	–	–	–	–	–	$f_S = 11.025/12\text{-kHz}$ sample rate
–	–	–	0	0	0	–	–	MCLK frequency = $64 \times f_S$ <sup>(3)</sup>
–	–	–	0	0	1	–	–	MCLK frequency = $128 \times f_S$ <sup>(3)</sup>
–	–	–	0	1	0	–	–	MCLK frequency = $192 \times f_S$ <sup>(4)</sup>
–	–	–	<b>0</b>	<b>1</b>	<b>1</b>	–	–	<b>MCLK frequency = <math>256 \times f_S</math></b> <sup>(2) (5)</sup>
–	–	–	1	0	0	–	–	MCLK frequency = $384 \times f_S$
–	–	–	1	0	1	–	–	MCLK frequency = $512 \times f_S$
–	–	–	1	1	0	–	–	Reserved <sup>(1)</sup>
–	–	–	1	1	1	–	–	Reserved <sup>(1)</sup>
–	–	–	–	–	–	<b>0</b>	–	<b>Reserved<sup>(1) (2)</sup></b>
–	–	–	–	–	–	–	<b>0</b>	<b>Reserved<sup>(1) (2)</sup></b>

(1) Reserved registers should not be accessed.

(2) Default values are in **bold**.

(3) Only available for 44.1-kHz and 48-kHz rates

(4) Rate only available for 32/44.1/48-KHz sample rates

(5) Not available at 8 kHz

## DEVICE ID REGISTER (0x01)

The device ID register contains the ID code for the firmware revision.

**Table 5. General Status Register (0x01)**

D7	D6	D5	D4	D3	D2	D1	D0	FUNCTION
<b>0</b>	<b>0</b>	<b>0</b>	<b>0</b>	<b>0</b>	<b>0</b>	<b>0</b>	<b>0</b>	<b>Identification code</b>

## ERROR STATUS REGISTER (0x02)

The error bits are sticky and are not cleared by the hardware. This means that the software must clear the register (write zeroes) and then read them to determine if they are persistent errors.

Error Definitions:

- MCLK Error : MCLK frequency is changing. The number of MCLKs per LRCLK is changing.
- SCLK Error: The number of SCLKs per LRCLK is changing.
- LRCLK Error: LRCLK frequency is changing.
- Frame Slip: LRCLK phase is drifting with respect to internal Frame Sync.

**Table 6. Error Status Register (0x02)**

D7	D6	D5	D4	D3	D2	D1	D0	FUNCTION
1	-	-	-	-	-	-	-	MCLK error
-	1	-	-	-	-	-	-	PLL autolock error
-	-	1	-	-	-	-	-	SCLK error
-	-	-	1	-	-	-	-	LRCLK error
-	-	-	-	1	-	-	-	Frame slip
-	-	-	-	-	1	-	-	Clip indicator
-	-	-	-	-	-	1	-	Overcurrent, overtemperature, or undervoltage errors
-	-	-	-	-	-	-	<b>0</b>	<b>Reserved</b>
<b>0</b>	<b>0</b>	<b>0</b>	<b>0</b>	<b>0</b>	<b>0</b>	<b>0</b>	-	<b>No errors <sup>(1)</sup></b>

(1) Default values are in **bold**.

## SYSTEM CONTROL REGISTER 1 (0x03)

The system control register 1 has several functions:

Bit D7: If 0, the dc-blocking filter for each channel is disabled.

If 1, the dc-blocking filter (-3 dB cutoff <1 Hz) for each channel is enabled (default).

Bit D5: If 0, use soft unmute on recovery from clock error. This is a slow recovery. Unmute takes the same time as the volume ramp defined in register 0x0E.

If 1, use hard unmute on recovery from clock error (default). This is a fast recovery, a single step volume ramp

Bits D1–D0: Select de-emphasis

**Table 7. System Control Register 1 (0x03)**

D7	D6	D5	D4	D3	D2	D1	D0	FUNCTION
0	-	-	-	-	-	-	-	PWM high-pass (dc blocking) disabled
1	-	-	-	-	-	-	-	<b>PWM high-pass (dc blocking) enabled <sup>(1)</sup></b>
-	<b>0</b>	-	-	-	-	-	-	<b>Reserved <sup>(1)</sup></b>
-	-	0	-	-	-	-	-	Soft unmute on recovery from clock error
-	-	<b>1</b>	-	-	-	-	-	<b>Hard unmute on recovery from clock error <sup>(1)</sup></b>
-	-	-	<b>0</b>	-	-	-	-	<b>Reserved <sup>(1)</sup></b>
-	-	-	-	<b>0</b>	-	-	-	<b>Reserved <sup>(1)</sup></b>
-	-	-	-	-	<b>0</b>	-	-	<b>Reserved <sup>(1)</sup></b>
-	-	-	-	-	-	<b>0</b>	<b>0</b>	<b>No de-emphasis <sup>(1)</sup></b>
-	-	-	-	-	-	0	1	De-emphasis for $f_S = 32$ kHz
-	-	-	-	-	-	1	0	De-emphasis for $f_S = 44.1$ kHz
-	-	-	-	-	-	1	1	De-emphasis for $f_S = 48$ kHz

(1) Default values are in **bold**.

## SERIAL DATA INTERFACE REGISTER (0x04)

As shown in [Table 8](#), the TAS5731 supports 9 serial data modes. The default is 24-bit, I<sup>2</sup>S mode,

**Table 8. Serial Data Interface Control Register (0x04) Format**

RECEIVE SERIAL DATA INTERFACE FORMAT	WORD LENGTH	D7–D4	D3	D2	D1	D0
Right-justified	16	0000	0	0	0	0
Right-justified	20	0000	0	0	0	1
Right-justified	24	0000	0	0	1	0
I <sup>2</sup> S	16	000	0	0	1	1
I <sup>2</sup> S	20	0000	0	1	0	0
<b>I<sup>2</sup>S</b> <sup>(1)</sup>	<b>24</b>	<b>0000</b>	<b>0</b>	<b>1</b>	<b>0</b>	<b>1</b>
Left-justified	16	0000	0	1	1	0
Left-justified	20	0000	0	1	1	1
Left-justified	24	0000	1	0	0	0
Reserved		0000	1	0	0	1
Reserved		0000	1	0	1	0
Reserved		0000	1	0	1	1
Reserved		0000	1	1	0	0
Reserved		0000	1	1	0	1
Reserved		0000	1	1	1	0
Reserved		0000	1	1	1	1

(1) Default values are in **bold**.

## SYSTEM CONTROL REGISTER 2 (0x05)

When bit D6 is set low, the system exits all channel shutdown and starts playing audio; otherwise, the outputs are shut down (hard mute).

**Table 9. System Control Register 2 (0x05)**

D7	D6	D5	D4	D3	D2	D1	D0	FUNCTION
<b>0</b>	–	–	–	–	–	–	–	<b>Mid-Z ramp disabled</b> <sup>(1)</sup>
<b>1</b>	–	–	–	–	–	–	–	Mid-Z ramp enabled
–	<b>0</b>	–	–	–	–	–	–	Exit all-channel shutdown (normal operation)
–	<b>1</b>	–	–	–	–	–	–	<b>Enter all-channel shutdown (hard mute)</b> <sup>(1)</sup>
				<b>0</b>				<b>Sub-channel in AD Mode</b>
				1				Sub-channel in BD Mode
–	–	–	–	–	<b>0</b>	–	–	<b>2.0 mode [2.0 BTL]</b> <sup>(1)</sup>
–	–	–	–	–	1	–	–	2.1 mode [2 SE + 1 BTL]
–	–	–	–	–	–	<b>0</b>	–	<b>ADR/<math>\overline{\text{FAULT}}</math> pin is configured as to serve as an address input only</b> <sup>(1)</sup>
–	–	–	–	–	–	1	–	ADR/ $\overline{\text{FAULT}}$ pin is configured as fault output
–	–	<b>0</b>	<b>0</b>	–	–	–	<b>0</b>	<b>Reserved</b> <sup>(1)</sup>

(1) Default values are in **bold**.

## SOFT MUTE REGISTER (0x06)

Writing a 1 to any of the following bits sets the output of the respective channel to 50% duty cycle (soft mute).

**Table 10. Soft Mute Register (0x06)**

D7	D6	D5	D4	D3	D2	D1	D0	FUNCTION
<b>0</b>	<b>0</b>	<b>0</b>	<b>0</b>	<b>0</b>	–	–	–	<b>Reserved</b> <sup>(1)</sup>
–	–	–	–	–	<b>0</b>	–	–	<b>Soft unmute channel 3</b> <sup>(1)</sup>
–	–	–	–	–	1	–	–	Soft mute channel 3
–	–	–	–	–	–	<b>0</b>	–	<b>Soft unmute channel 2</b> <sup>(1)</sup>
–	–	–	–	–	–	1	–	Soft mute channel 2
–	–	–	–	–	–	–	<b>0</b>	<b>Soft unmute channel 1</b> <sup>(1)</sup>
–	–	–	–	–	–	–	1	Soft mute channel 1

(1) Default values are in **bold**.

## VOLUME REGISTERS (0x07, 0x08, 0x09, 0x0A)

Step size is 0.5 dB.

Master volume	– 0x07 (default is mute)
Channel-1 volume	– 0x08 (default is 0 dB)
Channel-2 volume	– 0x09 (default is 0 dB)
Channel-3 volume	– 0x0A (default is 0 dB)

**Table 11. Volume Registers (0x07, 0x08, 0x09, 0x0A)**

D7	D6	D5	D4	D3	D2	D1	D0	FUNCTION
0	0	0	0	0	0	0	0	24 dB
<b>0</b>	<b>0</b>	<b>1</b>	<b>1</b>	<b>0</b>	<b>0</b>	<b>0</b>	<b>0</b>	<b>0 dB (default for individual channel volume) <sup>(1)</sup></b>
1	1	1	1	1	1	1	0	–103 dB
1	1	1	1	1	1	1	1	Soft mute

(1) Default values are in **bold**.

## VOLUME CONFIGURATION REGISTER (0x0E)

Bits D2–D0: Volume slew rate (Used to control volume change and MUTE ramp rates). These bits control the number of steps in a volume ramp. Volume steps occur at a rate that depends on the sample rate of the I2S data as follows

Sample Rate (KHz)	Approximate Ramp Rate
8/16/32	125 us/step
11.025/22.05/44.1	90.7 us/step
12/24/48	83.3 us/step

**Table 12. Volume Control Register (0x0E)**

D7	D6	D5	D4	D3	D2	D1	D0	FUNCTION
<b>1</b>	–	–	<b>1</b>	<b>0</b>	–	–	–	<b>Reserved <sup>(1)</sup></b>
–	<b>0</b>	–	–	–	–	–	–	<b>Subchannel (ch4) volume = ch1 volume <sup>(2)(1)</sup></b>
–	1	–	–	–	–	–	–	Subchannel volume = register 0x0A <sup>(2)</sup>
–	–	<b>0</b>	–	–	–	–	–	<b>Ch3 volume = ch2 volume <sup>(1)</sup></b>
–	–	1	–	–	–	–	–	Ch3 volume = register 0x0A
–	–	–	–	–	0	0	0	Volume slew 512 steps (43-ms volume ramp time at 48 kHz)
–	–	–	–	–	<b>0</b>	<b>0</b>	<b>1</b>	<b>Volume slew 1024 steps (85-ms volume ramp time at 48 kHz) <sup>(1)</sup></b>
–	–	–	–	–	0	1	0	Volume slew 2048 steps (171- ms volume ramp time at 48 kHz)
–	–	–	–	–	0	1	1	Volume slew 256 steps (21-ms volume ramp time at 48 kHz)
–	–	–	–	–	1	X	X	Reserved

(1) Default values are in **bold**.

(2) Bits 6:5 can be changed only when volume is in MUTE [master volume = MUTE (register 0x07 = 0xFF)].

## MODULATION LIMIT REGISTER (0x10)

The modulation limit is the maximum duty cycle of the PWM output waveform.

**Table 13. Modulation Limit Register (0x10)**

D7	D6	D5	D4	D3	D2	D1	D0	MODULATION LIMIT
–	–	–	–	–	0	0	0	99.2%
–	–	–	–	–	0	0	1	98.4%
–	–	–	–	–	<b>0</b>	<b>1</b>	<b>0</b>	<b>97.7%</b> <sup>(1)</sup>
–	–	–	–	–	0	1	1	96.9%
–	–	–	–	–	1	0	0	96.1%
–	–	–	–	–	1	0	1	95.3%
–	–	–	–	–	1	1	0	94.5%
–	–	–	–	–	1	1	1	93.8%
0	0	0	0	0	–	–	–	RESERVED

(1) Default values are in **bold**.

## INTERCHANNEL DELAY REGISTERS (0x11, 0x12, 0x13, and 0x14)

Internal PWM Channels 1, 2,  $\bar{1}$ , and  $\bar{2}$  are mapped into registers 0x11, 0x12, 0x13, and 0x14.

**Table 14. Channel Interchannel Delay Register Format**

BITS DEFINITION	D7	D6	D5	D4	D3	D2	D1	D0	FUNCTION
	0	0	0	0	0	0	–	–	Minimum absolute delay, 0 DCLK cycles
	0	1	1	1	1	1	–	–	Maximum positive delay, 31 × 4 DCLK cycles
	1	0	0	0	0	0	–	–	Maximum negative delay, –32 × 4 DCLK cycles
							0	0	RESERVED
SUBADDRESS	D7	D6	D5	D4	D3	D2	D1	D0	Delay = (value) × 4 DCLKs
<b>0x11</b>	<b>1</b>	<b>0</b>	<b>1</b>	<b>0</b>	<b>1</b>	<b>1</b>	–	–	<b>Default value for channel 1</b> <sup>(1)</sup>
<b>0x12</b>	<b>0</b>	<b>1</b>	<b>0</b>	<b>1</b>	<b>0</b>	<b>1</b>	–	–	<b>Default value for channel 2</b> <sup>(1)</sup>
<b>0x13</b>	<b>1</b>	<b>0</b>	<b>1</b>	<b>0</b>	<b>1</b>	<b>1</b>	–	–	<b>Default value for channel <math>\bar{1}</math></b> <sup>(1)</sup>
<b>0x14</b>	<b>0</b>	<b>1</b>	<b>0</b>	<b>1</b>	<b>0</b>	<b>1</b>	–	–	<b>Default value for channel <math>\bar{2}</math></b> <sup>(1)</sup>

(1) Default values are in **bold**.

ICD settings have high impact on audio performance (e.g., dynamic range, THD, crosstalk etc.). Therefore, appropriate ICD settings must be used. By default, the device has ICD settings for AD mode. If used in BD mode, then update these registers before coming out of all-channel shutdown.

REGISTER	AD MODE	BD MODE
0x11	AC	B8
0x12	54	60
0x13	AC	A0
0x14	54	48

## PWM SHUTDOWN GROUP REGISTER (0x19)

Settings of this register determine which PWM channels are active. The value should be 0x30 for BTL mode and 0x3A for PBT mode. The default value of this register is 0x30. The functionality of this register is tied to the state of bit D5 in the system control register.

This register defines which channels belong to the shutdown group (SDG). If a 1 is set in the shutdown group register, that particular channel is **not** started following an exit *out of all-channel shutdown* command (if bit D5 is set to 0 in system control register 2, 0x05).

**Table 15. Shutdown Group Register**

D7	D6	D5	D4	D3	D2	D1	D0	FUNCTION
<b>0</b>	–	–	–	–	–	–	–	Reserved <sup>(1)</sup>
–	<b>0</b>	–	–	–	–	–	–	Reserved <sup>(1)</sup>
–	–	<b>1</b>	–	–	–	–	–	Reserved <sup>(1)</sup>
–	–	–	<b>1</b>	–	–	–	–	Reserved <sup>(1)</sup>
–	–	–	–	<b>0</b>	–	–	–	PWM channel 4 does not belong to shutdown group. <sup>(1)</sup>
–	–	–	–	1	–	–	–	PWM channel 4 belongs to shutdown group.
–	–	–	–	–	<b>0</b>	–	–	PWM channel 3 does not belong to shutdown group. <sup>(1)</sup>
–	–	–	–	–	1	–	–	PWM channel 3 belongs to shutdown group.
–	–	–	–	–	–	<b>0</b>	–	PWM channel 2 does not belong to shutdown group. <sup>(1)</sup>
–	–	–	–	–	–	1	–	PWM channel 2 belongs to shutdown group.
–	–	–	–	–	–	–	<b>0</b>	PWM channel 1 does not belong to shutdown group. <sup>(1)</sup>
–	–	–	–	–	–	–	1	PWM channel 1 belongs to shutdown group.

(1) Default values are in **bold**.

## START/STOP PERIOD REGISTER (0x1A)

This register is used to control the soft-start and soft-stop period following an enter/exit all channel shut down command or change in the PDN state. This helps reduce pops and clicks at start-up and shutdown. The times are only approximate and vary depending on device activity level and I2S clock stability.

**Table 16. Start/Stop Period Register (0x1A)**

D7	D6	D5	D4	D3	D2	D1	D0	FUNCTION
<b>0</b>	–	–	–	–	–	–	–	<b>SSTIMER enabled<sup>(1)</sup></b>
1	–	–	–	–	–	–	–	SSTIMER disabled
–	<b>0</b>	<b>0</b>	–	–	–	–	–	<b>Reserved<sup>(1)</sup></b>
–	–	–	0	0	–	–	–	No 50% duty cycle start/stop period
–	–	–	0	1	0	0	0	16.5-ms 50% duty cycle start/stop period
–	–	–	0	1	0	0	1	23.9-ms 50% duty cycle start/stop period
–	–	–	0	1	0	1	0	31.4-ms 50% duty cycle start/stop period
–	–	–	0	1	0	1	1	40.4-ms 50% duty cycle start/stop period
–	–	–	0	1	1	0	0	53.9-ms 50% duty cycle start/stop period
–	–	–	0	1	1	0	1	70.3-ms 50% duty cycle start/stop period
–	–	–	0	1	1	1	0	94.2-ms 50% duty cycle start/stop period
–	–	–	<b>0</b>	<b>1</b>	<b>1</b>	<b>1</b>	<b>1</b>	<b>125.7-ms 50% duty cycle start/stop period<sup>(1)</sup></b>
–	–	–	1	0	0	0	0	164.6-ms 50% duty cycle start/stop period
–	–	–	1	0	0	0	1	239.4-ms 50% duty cycle start/stop period
–	–	–	1	0	0	1	0	314.2-ms 50% duty cycle start/stop period
–	–	–	1	0	0	1	1	403.9-ms 50% duty cycle start/stop period
–	–	–	1	0	1	0	0	538.6-ms 50% duty cycle start/stop period
–	–	–	1	0	1	0	1	703.1-ms 50% duty cycle start/stop period
–	–	–	1	0	1	1	0	942.5-ms 50% duty cycle start/stop period
–	–	–	1	0	1	1	1	1256.6-ms 50% duty cycle start/stop period
–	–	–	1	1	0	0	0	1728.1-ms 50% duty cycle start/stop period
–	–	–	1	1	0	0	1	2513.6-ms 50% duty cycle start/stop period
–	–	–	1	1	0	1	0	3299.1-ms 50% duty cycle start/stop period
–	–	–	1	1	0	1	1	4241.7-ms 50% duty cycle start/stop period
–	–	–	1	1	1	0	0	5655.6-ms 50% duty cycle start/stop period
–	–	–	1	1	1	0	1	7383.7-ms 50% duty cycle start/stop period
–	–	–	1	1	1	1	0	9897.3-ms 50% duty cycle start/stop period
–	–	–	1	1	1	1	1	13,196.4-ms 50% duty cycle start/stop period

(1) Default values are in **bold**.

## OSCILLATOR TRIM REGISTER (0x1B)

The TAS5731 PWM processor contains an internal oscillator to support autodetect of I<sup>2</sup>S clock rates. This reduces system cost because an external reference is not required. Currently, TI recommends a reference resistor value of 18.2 kΩ (1%). This should be connected between OSC\_RES and DVSSO.

Writing 0x00 to register 0x1B enables the trim that was programmed at the factory.

Note that trim must always be run following reset of the device.

**Table 17. Oscillator Trim Register (0x1B)**

D7	D6	D5	D4	D3	D2	D1	D0	FUNCTION
<b>1</b>	–	–	–	–	–	–	–	Reserved <sup>(1)</sup>
–	<b>0</b>	–	–	–	–	–	–	Oscillator trim not done (read-only) <sup>(1)</sup>
–	1	–	–	–	–	–	–	Oscillator trim done (read only)
–	–	<b>0</b>	<b>0</b>	<b>0</b>	<b>0</b>	–	–	Reserved <sup>(1)</sup>
–	–	–	–	–	–	0	–	Select factory trim (Write a 0 to select factory trim; default is 1.)
–	–	–	–	–	–	1	–	Factory trim disabled <sup>(1)</sup>
–	–	–	–	–	–	–	<b>0</b>	Reserved <sup>(1)</sup>

(1) Default values are in **bold**.

## BKND\_ERR REGISTER (0x1C)

When a back-end error signal is received from the internal power stage, the power stage is reset stopping all PWM activity. Subsequently, the modulator waits approximately for the time listed in [Table 18](#) before attempting to re-start the power stage.

**Table 18. BKND\_ERR Register (0x1C)<sup>(1)</sup>**

D7	D6	D5	D4	D3	D2	D1	D0	FUNCTION
0	0	0	0	0	0	0	X	Reserved
–	–	–	–	<b>0</b>	<b>0</b>	<b>1</b>	<b>0</b>	Set back-end reset period to 299 ms <sup>(2)</sup>
–	–	–	–	0	0	1	1	Set back-end reset period to 449 ms
–	–	–	–	0	1	0	0	Set back-end reset period to 598 ms
–	–	–	–	0	1	0	1	Set back-end reset period to 748 ms
–	–	–	–	0	1	1	0	Set back-end reset period to 898 ms
–	–	–	–	0	1	1	1	Set back-end reset period to 1047 ms
–	–	–	–	1	0	0	0	Set back-end reset period to 1197 ms
–	–	–	–	1	0	0	1	Set back-end reset period to 1346 ms
–	–	–	–	1	0	1	X	Set back-end reset period to 1496 ms
–	–	–	–	1	1	X	X	Set back-end reset period to 1496 ms

(1) This register can be written only with a "non-Reserved" value. Also this register can be written once after the reset.

(2) Default values are in **bold**.

**INPUT MULTIPLEXER REGISTER (0x20)**

This register controls the modulation scheme (AD or BD mode) as well as the routing of I2S audio to the internal channels.

**Table 19. Input Multiplexer Register (0x20)**

D31	D30	D29	D28	D27	D26	D25	D24	FUNCTION
0	0	0	0	0	0	0	0	Reserved <sup>(1)</sup>
D23	D22	D21	D20	D19	D18	D17	D16	FUNCTION
0	–	–	–	–	–	–	–	<b>Channel-1 AD mode</b> <sup>(1)</sup>
1	–	–	–	–	–	–	–	Channel-1 BD mode
–	<b>0</b>	<b>0</b>	<b>0</b>	–	–	–	–	<b>SDIN-L to channel 1</b> <sup>(1)</sup>
–	0	0	1	–	–	–	–	SDIN-R to channel 1
–	0	1	0	–	–	–	–	Reserved
–	0	1	1	–	–	–	–	Reserved
–	1	0	0	–	–	–	–	Reserved
–	1	0	1	–	–	–	–	Reserved
–	1	1	0	–	–	–	–	Ground (0) to channel 1
–	1	1	1	–	–	–	–	Reserved
–	–	–	–	<b>0</b>	–	–	–	<b>Channel 2 AD mode</b> <sup>(1)</sup>
–	–	–	–	1	–	–	–	Channel 2 BD mode
–	–	–	–	–	0	0	0	SDIN-L to channel 2
–	–	–	–	–	<b>0</b>	<b>0</b>	<b>1</b>	<b>SDIN-R to channel 2</b> <sup>(1)</sup>
–	–	–	–	–	0	1	0	Reserved
–	–	–	–	–	0	1	1	Reserved
–	–	–	–	–	1	0	0	Reserved
–	–	–	–	–	1	0	1	Reserved
–	–	–	–	–	1	1	0	Ground (0) to channel 2
–	–	–	–	–	1	1	1	Reserved
D15	D14	D13	D12	D11	D10	D9	D8	FUNCTION
0	1	1	1	0	1	1	1	Reserved <sup>(1)</sup>
D7	D6	D5	D4	D3	D2	D1	D0	FUNCTION
0	1	1	1	0	0	1	0	Reserved <sup>(1)</sup>

(1) Default values are in **bold**.

## CHANNEL 4 SOURCE SELECT REGISTER (0x21)

This register selects the channel 4 source.

**Table 20. Subchannel Control Register (0x21)**

D31	D30	D29	D28	D27	D26	D25	D24	FUNCTION
<b>0</b>	<b>0</b>	<b>0</b>	<b>0</b>	<b>0</b>	<b>0</b>	<b>0</b>	<b>0</b>	Reserved <sup>(1)</sup>
D23	D22	D21	D20	D19	D18	D17	D16	FUNCTION
<b>0</b>	<b>0</b>	<b>0</b>	<b>0</b>	<b>0</b>	<b>0</b>	<b>0</b>	<b>0</b>	Reserved <sup>(1)</sup>
D15	D14	D13	D12	D11	D10	D9	D8	FUNCTION
<b>0</b>	<b>1</b>	<b>0</b>	<b>0</b>	<b>0</b>	<b>0</b>	<b>1</b>	<b>1</b>	Select SDIN path (third path), not available in TAS5731 <sup>(1)</sup>
–	–	–	–	–	–	–	0	(L + R)/2
–	–	–	–	–	–	0	1	Left-channel post-BQ <sup>(1)</sup>
D7	D6	D5	D4	D3	D2	D1	D0	FUNCTION
<b>0</b>	<b>0</b>	<b>0</b>	<b>0</b>	<b>0</b>	<b>0</b>	<b>1</b>	<b>1</b>	Reserved <sup>(1)</sup>

(1) Default values are in **bold**.

## PWM OUTPUT MUX REGISTER (0x25)

This DAP output mux selects which internal PWM channel is output to the external pins. Any channel can be output to any external output pin.

Bits D21–D20: Selects which PWM channel is output to OUT\_A

Bits D17–D16: Selects which PWM channel is output to OUT\_B

Bits D13–D12: Selects which PWM channel is output to OUT\_C

Bits D09–D08: Selects which PWM channel is output to OUT\_D

Note that channels are encoded so that channel 1 = 0x00, channel 2 = 0x01, ..., channel 4 = 0x03.

**Table 21. PWM Output Mux Register (0x25)**

D31	D30	D29	D28	D27	D26	D25	D24	FUNCTION
<b>0</b>	<b>0</b>	<b>0</b>	<b>0</b>	<b>0</b>	<b>0</b>	<b>0</b>	<b>1</b>	Reserved <sup>(1)</sup>
D23	D22	D21	D20	D19	D18	D17	D16	FUNCTION
<b>0</b>	<b>0</b>	–	–	–	–	–	–	Reserved <sup>(1)</sup>
–	–	<b>0</b>	<b>0</b>	–	–	–	–	Multiplex PWM 1 to OUT_A <sup>(1)</sup>
–	–	0	1	–	–	–	–	Multiplex PWM 2 to OUT_A
–	–	1	0	–	–	–	–	Multiplex PWM 3 to OUT_A
–	–	1	1	–	–	–	–	Multiplex PWM 4 to OUT_A
–	–	–	–	<b>0</b>	<b>0</b>	–	–	Reserved <sup>(1)</sup>
–	–	–	–	–	–	0	0	Multiplex PWM 1 to OUT_B
–	–	–	–	–	–	0	1	Multiplex PWM 2 to OUT_B
–	–	–	–	–	–	<b>1</b>	<b>0</b>	Multiplex PWM 3 to OUT_B <sup>(1)</sup>
–	–	–	–	–	–	1	1	Multiplex PWM 4 to OUT_B
D15	D14	D13	D12	D11	D10	D9	D8	FUNCTION
<b>0</b>	<b>0</b>	–	–	–	–	–	–	Reserved <sup>(1)</sup>
–	–	0	0	–	–	–	–	Multiplex PWM 1 to OUT_C
–	–	<b>0</b>	<b>1</b>	–	–	–	–	Multiplex PWM 2 to OUT_C <sup>(1)</sup>

(1) Default values are in **bold**.

**Table 21. PWM Output Mux Register (0x25) (continued)**

–	–	1	0	–	–	–	–	Multiplex PWM 3 to OUT_C
–	–	1	1	–	–	–	–	Multiplex PWM 4 to OUT_C
–	–	–	–	<b>0</b>	<b>0</b>	–	–	<b>Reserved</b> <sup>(1)</sup>
–	–	–	–	–	–	0	0	Multiplex PWM 1 to OUT_D
–	–	–	–	–	–	0	1	Multiplex PWM 2 to OUT_D
–	–	–	–	–	–	1	0	Multiplex PWM 3 to OUT_D
–	–	–	–	–	–	<b>1</b>	<b>1</b>	<b>Multiplex PWM 4 to OUT_D</b> <sup>(1)</sup>
<b>D7</b>	<b>D6</b>	<b>D5</b>	<b>D4</b>	<b>D3</b>	<b>D2</b>	<b>D1</b>	<b>D0</b>	<b>FUNCTION</b>
<b>0</b>	<b>1</b>	<b>0</b>	<b>0</b>	<b>0</b>	<b>1</b>	<b>0</b>	<b>1</b>	<b>Reserved</b> <sup>(1)</sup>

**DRC CONTROL (0x46)**

Each DRC can be enabled independently using the DRC control register. The DRCs are disabled by default.

**Table 22. DRC Control Register**

<b>D31</b>	<b>D30</b>	<b>D29</b>	<b>D28</b>	<b>D27</b>	<b>D26</b>	<b>D25</b>	<b>D24</b>	<b>FUNCTION</b>
<b>0</b>	<b>0</b>	<b>0</b>	<b>0</b>	<b>0</b>	<b>0</b>	<b>0</b>	<b>0</b>	<b>Reserved</b> <sup>(1)</sup>
<b>D23</b>	<b>D22</b>	<b>D21</b>	<b>D20</b>	<b>D19</b>	<b>D18</b>	<b>D17</b>	<b>D16</b>	<b>FUNCTION</b>
<b>0</b>	<b>0</b>	<b>0</b>	<b>0</b>	<b>0</b>	<b>0</b>	<b>0</b>	<b>0</b>	<b>Reserved</b> <sup>(1)</sup>
<b>D15</b>	<b>D14</b>	<b>D13</b>	<b>D12</b>	<b>D11</b>	<b>D10</b>	<b>D9</b>	<b>D8</b>	<b>FUNCTION</b>
<b>0</b>	<b>0</b>	<b>0</b>	<b>0</b>	<b>0</b>	<b>0</b>	<b>0</b>	<b>0</b>	<b>Reserved</b> <sup>(1)</sup>
<b>D7</b>	<b>D6</b>	<b>D5</b>	<b>D4</b>	<b>D3</b>	<b>D2</b>	<b>D1</b>	<b>D0</b>	<b>FUNCTION</b>
<b>0</b>	<b>0</b>	–	–	–	–	–	–	<b>Reserved</b> <sup>(1)</sup>
–	–	0	–	–	–	–	–	Disable complementary (1 - H) low-pass filter generation
–	–	1	–	–	–	–	–	Enable complementary (1 - H) low-pass filter generation
–	–	–	<b>0</b>	–	–	–	–	
–	–	–	1	–	–	–	–	
				<b>0</b>	<b>0</b>			<b>Reserved</b> <sup>(1)</sup>
–	–	–	–	–	–	<b>0</b>	–	<b>DRC2 turned OFF</b> <sup>(1)</sup>
–	–	–	–	–	–	1	–	DRC2 turned ON
–	–	–	–	–	–	–	<b>0</b>	<b>DRC1 turned OFF</b> <sup>(1)</sup>
–	–	–	–	–	–	–	1	DRC1 turned ON

(1) Default values are in **bold**.

**BANK SWITCH AND EQ CONTROL (0x50)****Table 23. Bank Switching Command**

D31	D30	D29	D28	D27	D26	D25	D24	FUNCTION
<b>0</b>	–	–	–	–	–	–	–	<b>32 kHz, does not use bank 3</b> <sup>(1)</sup>
1	–	–	–	–	–	–	–	32 kHz, uses bank 3
–	<b>0</b>	–	–	–	–	–	–	<b>Reserved</b> <sup>(1)</sup>
–	–	<b>0</b>	–	–	–	–	–	<b>Reserved</b> <sup>(1)</sup>
–	–	–	<b>0</b>	–	–	–	–	<b>44.1/48 kHz, does not use bank 3</b> <sup>(1)</sup>
–	–	–	1	–	–	–	–	44.1/48 kHz, uses bank 3
–	–	–	–	0	–	–	–	16 kHz, does not use bank 3
–	–	–	–	<b>1</b>	–	–	–	<b>16 kHz, uses bank 3</b> <sup>(1)</sup>
–	–	–	–	–	0	–	–	22.025/24 kHz, does not use bank 3
–	–	–	–	–	<b>1</b>	–	–	<b>22.025/24 kHz, uses bank 3</b> <sup>(1)</sup>
–	–	–	–	–	–	0	–	8 kHz, does not use bank 3
–	–	–	–	–	–	<b>1</b>	–	<b>8 kHz, uses bank 3</b> <sup>(1)</sup>
–	–	–	–	–	–	–	0	11.025 kHz/12, does not use bank 3
–	–	–	–	–	–	–	<b>1</b>	<b>11.025/12 kHz, uses bank 3</b> <sup>(1)</sup>
D23	D22	D21	D20	D19	D18	D17	D16	FUNCTION
<b>0</b>	–	–	–	–	–	–	–	<b>32 kHz, does not use bank 2</b> <sup>(1)</sup>
1	–	–	–	–	–	–	–	32 kHz, uses bank 2
–	<b>1</b>	–	–	–	–	–	–	<b>Reserved</b> <sup>(1)</sup>
–	–	<b>1</b>	–	–	–	–	–	<b>Reserved</b> <sup>(1)</sup>
–	–	–	0	–	–	–	–	44.1/48 kHz, does not use bank 2
–	–	–	<b>1</b>	–	–	–	–	<b>44.1/48 kHz, uses bank 2</b> <sup>(1)</sup>
–	–	–	–	<b>0</b>	–	–	–	<b>16 kHz, does not use bank 2</b> <sup>(1)</sup>
–	–	–	–	1	–	–	–	16 kHz, uses bank 2
–	–	–	–	–	<b>0</b>	–	–	<b>22.025/24 kHz, does not use bank 2</b> <sup>(1)</sup>
–	–	–	–	–	1	–	–	22.025/24 kHz, uses bank 2
–	–	–	–	–	–	<b>0</b>	–	<b>8 kHz, does not use bank 2</b> <sup>(1)</sup>
–	–	–	–	–	–	1	–	8 kHz, uses bank 2
–	–	–	–	–	–	–	<b>0</b>	<b>11.025/12 kHz, does not use bank 2</b> <sup>(1)</sup>
–	–	–	–	–	–	–	1	11.025/12 kHz, uses bank 2
D15	D14	D13	D12	D11	D10	D9	D8	FUNCTION
<b>0</b>	–	–	–	–	–	–	–	32 kHz, does not use bank 1
1	–	–	–	–	–	–	–	<b>32 kHz, uses bank 1</b> <sup>(1)</sup>
–	<b>0</b>	–	–	–	–	–	–	<b>Reserved</b> <sup>(1)</sup>
–	–	<b>0</b>	–	–	–	–	–	<b>Reserved</b> <sup>(1)</sup>
–	–	–	<b>0</b>	–	–	–	–	<b>44.1/48 kHz, does not use bank 1</b> <sup>(1)</sup>
–	–	–	1	–	–	–	–	44.1/48 kHz, uses bank 1
–	–	–	–	<b>0</b>	–	–	–	<b>16 kHz, does not use bank 1</b> <sup>(1)</sup>
–	–	–	–	1	–	–	–	16 kHz, uses bank 1
–	–	–	–	–	<b>0</b>	–	–	<b>22.025/24 kHz, does not use bank 1</b> <sup>(1)</sup>
–	–	–	–	–	1	–	–	22.025/24 kHz, uses bank 1
–	–	–	–	–	–	<b>0</b>	–	<b>8 kHz, does not use bank 1</b> <sup>(1)</sup>
–	–	–	–	–	–	1	–	8 kHz, uses bank 1
–	–	–	–	–	–	–	<b>0</b>	<b>11.025/12 kHz, does not use bank 1</b> <sup>(1)</sup>
–	–	–	–	–	–	–	1	11.025/12 kHz, uses bank 1

(1) Default values are in **bold**.

**Table 23. Bank Switching Command (continued)**

D7	D6	D5	D4	D3	D2	D1	D0	FUNCTION
<b>0</b>								<b>EQ ON</b>
1	–	–	–	–	–	–	–	EQ OFF (bypass BQ 0-7 of channels 1 and 2)
–	<b>0</b>	–	–	–	–	–	–	<b>Reserved</b> <sup>(2)</sup>
–	–	<b>0</b>	–	–	–	–	–	<b>Ignore bank-mapping in bits D31–D8. Use default mapping.</b> <sup>(2)</sup>
		1						Use bank-mapping in bits D31–D8.
–	–	–	<b>0</b>	–	–	–	–	<b>L and R can be written independently.</b> <sup>(2)</sup>
–	–	–	1	–	–	–	–	L and R are ganged for EQ biquads; a write to left-channel BQ is also written to right-channel BQ. (0x29–0x2F is ganged to 0x30–0x36. Also 0x58–0x59 is ganged to 0x5C–0x5D)
–	–	–	–	<b>0</b>	–	–	–	<b>Reserved</b> <sup>(2)</sup>
–	–	–	–	–	<b>0</b>	<b>0</b>	<b>0</b>	<b>No bank switching. All updates to DAP</b> <sup>(2)</sup>
–	–	–	–	–	0	0	1	Configure bank 1 (32 kHz by default)
–	–	–	–	–	0	1	0	Configure bank 2 (44.1/48 kHz by default)
–	–	–	–	–	0	1	1	Configure bank 3 (other sample rates by default)
–	–	–	–	–	1	0	0	Automatic bank selection
–	–	–	–	–	1	0	1	Reserved
–	–	–	–	–	1	1	X	Reserved

(2) Default values are in **bold**.

## REVISION HISTORY

Changes from Original (December 2011) to Revision A	Page
• Changed pin 14 From: A_SEL To: ADR/ $\overline{\text{FALUT}}$ in the Pinout image and PIN FUNCTIONS table .....	6
• Changed Note 2 of the PIN FUNCTIONS table .....	6
• Changed the ROC - Half-bridge supply voltage MAX value From 21 To: 21.5 .....	8
• Changed $R_L$ (PBLT) in the ROC table .....	8
• Changed $V_{\text{uvp,hyst}}$ From: 5.4V To: 7.1V in the DC Characteristics table .....	9
• Changed the AC Characteristics (BTL, PBTL) table .....	10
• Deleted 0x63 and 0x64 from <a href="#">Table 3</a> .....	37
• Changed 0x65–0xF7 To: 0x63–0xF7 in <a href="#">Table 3</a> .....	37
• Changed From: BQ.(0x29–0x2F is ganged to 0x30–0x36. Also 0x58–0x5B is ganged to 0x5C–0x5F) To: BQ. (0x29–0x2F is ganged to 0x30–0x36. Also 0x58–0x59 is ganged to 0x5C–0x5D) in the EQ ON section of <a href="#">Table 23</a> .....	51

**PACKAGING INFORMATION**

Orderable Device	Status (1)	Package Type	Package Drawing	Pins	Package Qty	Eco Plan (2)	Lead finish/ Ball material (6)	MSL Peak Temp (3)	Op Temp (°C)	Device Marking (4/5)	Samples
TAS5731PHP	ACTIVE	HTQFP	PHP	48	250	RoHS & Green	NIPDAU	Level-3-260C-168 HR	-40 to 85	TAS5731	<b>Samples</b>
TAS5731PHPR	ACTIVE	HTQFP	PHP	48	1000	RoHS & Green	NIPDAU	Level-3-260C-168 HR	-40 to 85	TAS5731	<b>Samples</b>

(1) The marketing status values are defined as follows:

**ACTIVE:** Product device recommended for new designs.

**LIFEBUY:** TI has announced that the device will be discontinued, and a lifetime-buy period is in effect.

**NRND:** Not recommended for new designs. Device is in production to support existing customers, but TI does not recommend using this part in a new design.

**PREVIEW:** Device has been announced but is not in production. Samples may or may not be available.

**OBSELETE:** TI has discontinued the production of the device.

(2) **RoHS:** TI defines "RoHS" to mean semiconductor products that are compliant with the current EU RoHS requirements for all 10 RoHS substances, including the requirement that RoHS substance do not exceed 0.1% by weight in homogeneous materials. Where designed to be soldered at high temperatures, "RoHS" products are suitable for use in specified lead-free processes. TI may reference these types of products as "Pb-Free".

**RoHS Exempt:** TI defines "RoHS Exempt" to mean products that contain lead but are compliant with EU RoHS pursuant to a specific EU RoHS exemption.

**Green:** TI defines "Green" to mean the content of Chlorine (Cl) and Bromine (Br) based flame retardants meet JS709B low halogen requirements of <=1000ppm threshold. Antimony trioxide based flame retardants must also meet the <=1000ppm threshold requirement.

(3) MSL, Peak Temp. - The Moisture Sensitivity Level rating according to the JEDEC industry standard classifications, and peak solder temperature.

(4) There may be additional marking, which relates to the logo, the lot trace code information, or the environmental category on the device.

(5) Multiple Device Markings will be inside parentheses. Only one Device Marking contained in parentheses and separated by a "~" will appear on a device. If a line is indented then it is a continuation of the previous line and the two combined represent the entire Device Marking for that device.

(6) Lead finish/Ball material - Orderable Devices may have multiple material finish options. Finish options are separated by a vertical ruled line. Lead finish/Ball material values may wrap to two lines if the finish value exceeds the maximum column width.

**Important Information and Disclaimer:**The information provided on this page represents TI's knowledge and belief as of the date that it is provided. TI bases its knowledge and belief on information provided by third parties, and makes no representation or warranty as to the accuracy of such information. Efforts are underway to better integrate information from third parties. TI has taken and continues to take reasonable steps to provide representative and accurate information but may not have conducted destructive testing or chemical analysis on incoming materials and chemicals. TI and TI suppliers consider certain information to be proprietary, and thus CAS numbers and other limited information may not be available for release.

In no event shall TI's liability arising out of such information exceed the total purchase price of the TI part(s) at issue in this document sold by TI to Customer on an annual basis.

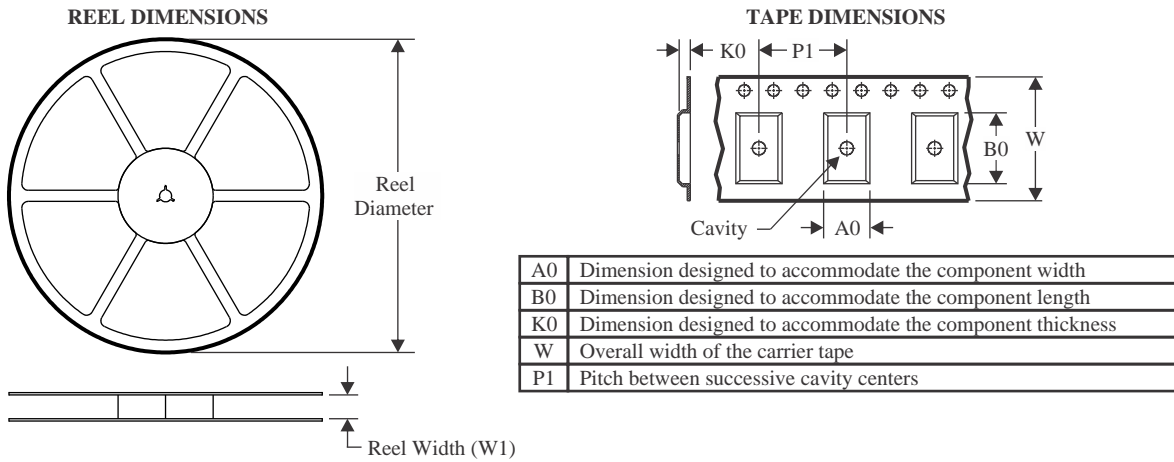
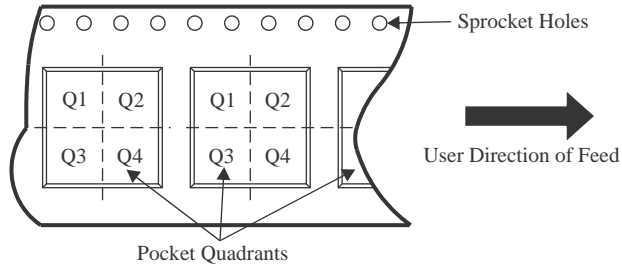

**TAPE AND REEL INFORMATION**

**QUADRANT ASSIGNMENTS FOR PIN 1 ORIENTATION IN TAPE**

\*All dimensions are nominal

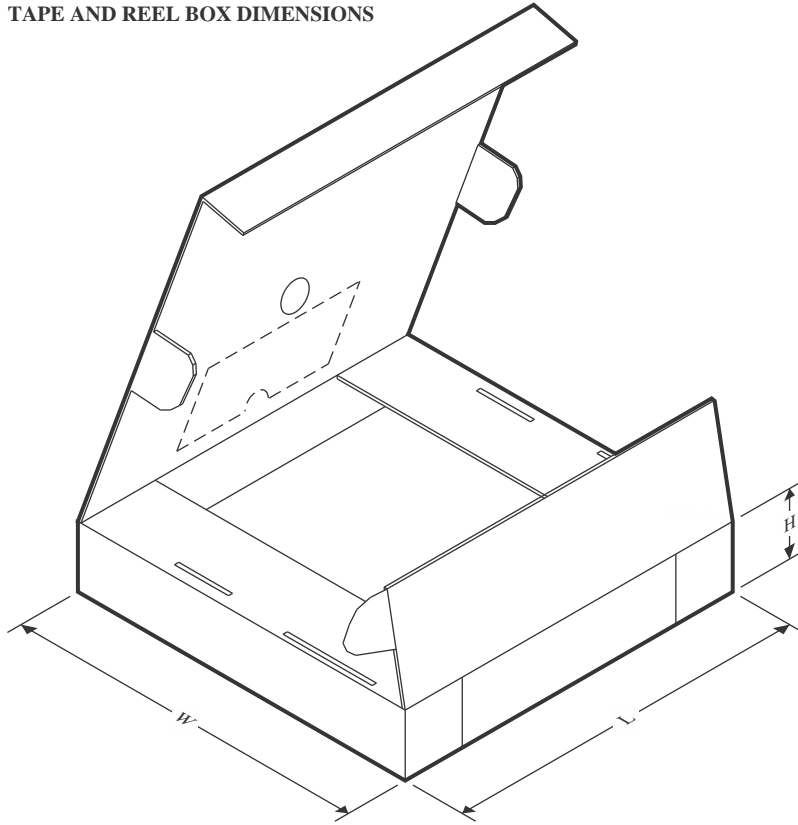
Device	Package Type	Package Drawing	Pins	SPQ	Reel Diameter (mm)	Reel Width W1 (mm)	A0 (mm)	B0 (mm)	K0 (mm)	P1 (mm)	W (mm)	Pin1 Quadrant
TAS5731PHPR	HTQFP	PHP	48	1000	330.0	16.4	9.6	9.6	1.5	12.0	16.0	Q2

**TAPE AND REEL BOX DIMENSIONS**

\*All dimensions are nominal

Device	Package Type	Package Drawing	Pins	SPQ	Length (mm)	Width (mm)	Height (mm)
TAS5731PHPR	HTQFP	PHP	48	1000	350.0	350.0	43.0

**TRAY**

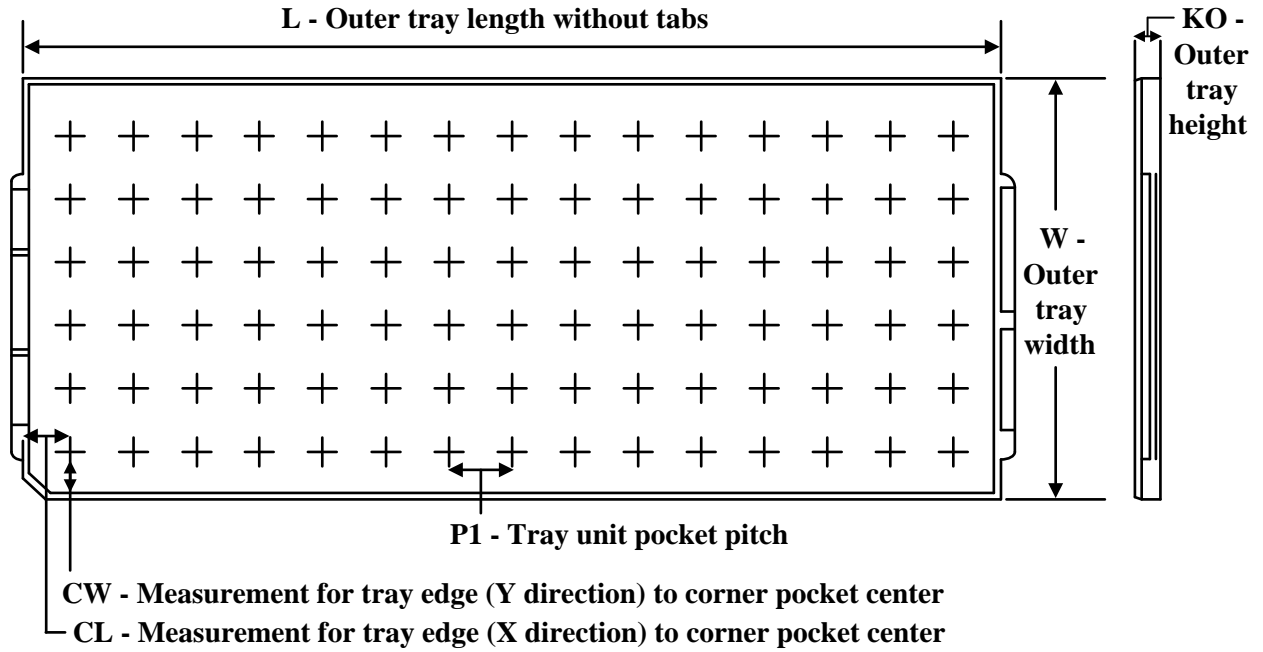

Chamfer on Tray corner indicates Pin 1 orientation of packed units.

\*All dimensions are nominal

Device	Package Name	Package Type	Pins	SPQ	Unit array matrix	Max temperature (°C)	L (mm)	W (mm)	K0 (µm)	P1 (mm)	CL (mm)	CW (mm)
TAS5731PHP	PHP	HTQFP	48	250	10 x 25	150	315	135.9	7620	12.2	11.1	11.25

## GENERIC PACKAGE VIEW

**PHP 48**

**TQFP - 1.2 mm max height**

7 x 7, 0.5 mm pitch

QUAD FLATPACK

This image is a representation of the package family, actual package may vary.  
Refer to the product data sheet for package details.

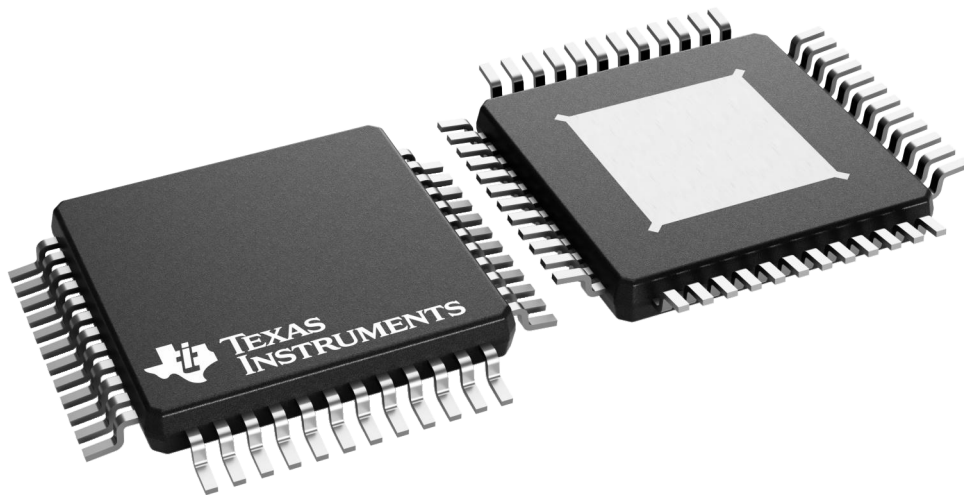

4226443/A

PHP (S-PQFP-G48)

PowerPAD™ PLASTIC QUAD FLATPACK

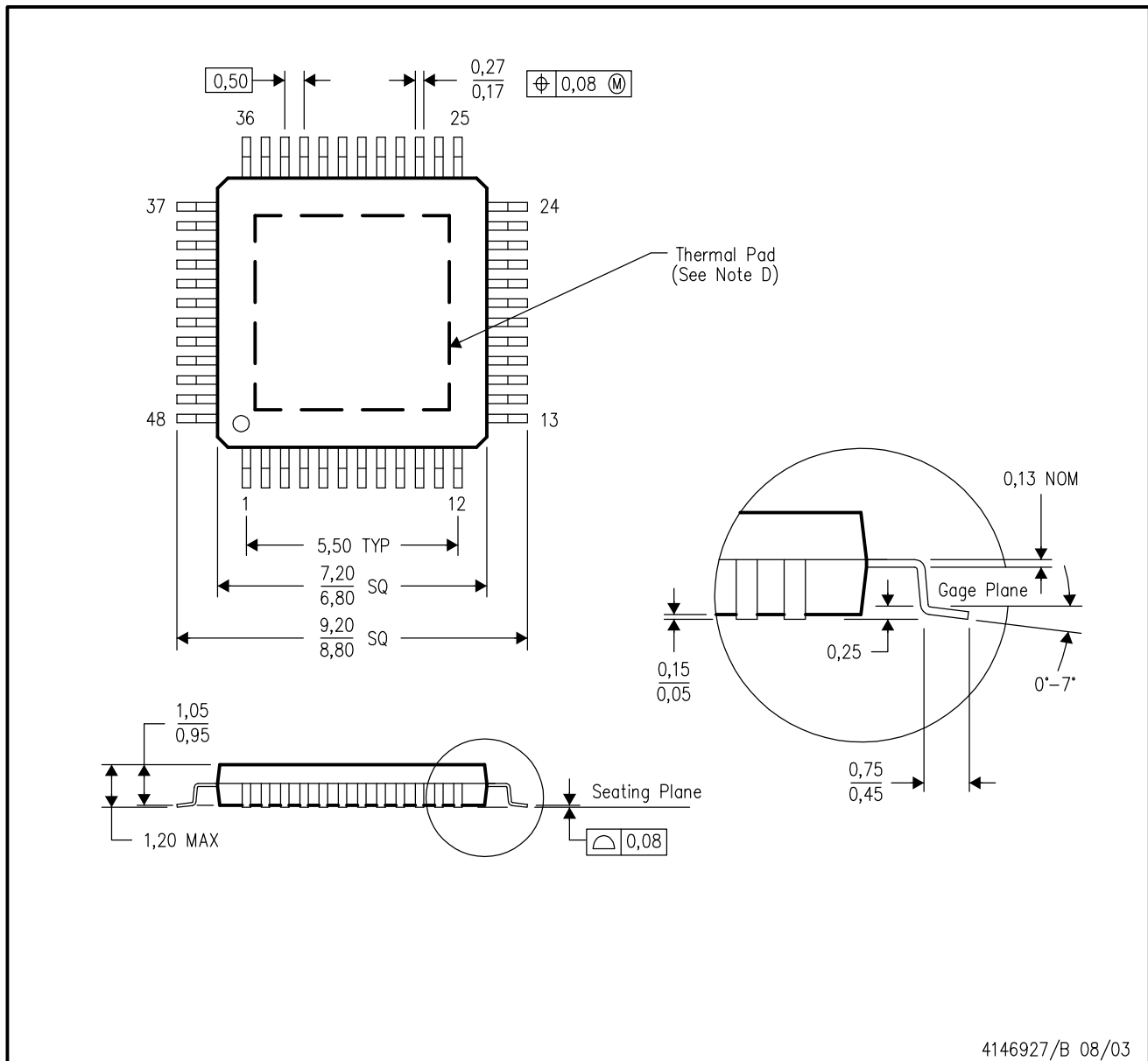

- NOTES:
- All linear dimensions are in millimeters.
  - This drawing is subject to change without notice.
  - Body dimensions do not include mold flash or protrusion.
  - This package is designed to be soldered to a thermal pad on the board. Refer to Technical Brief, PowerPad Thermally Enhanced Package, Texas Instruments Literature No. SLMA002 for information regarding recommended board layout. This document is available at [www.ti.com](http://www.ti.com) <<http://www.ti.com>>.
  - Falls within JEDEC MS-026

PowerPAD is a trademark of Texas Instruments.

# THERMAL PAD MECHANICAL DATA

PHP (S-PQFP-G48)

PowerPAD™ PLASTIC QUAD FLATPACK

## THERMAL INFORMATION

This PowerPAD™ package incorporates an exposed thermal pad that is designed to be attached to a printed circuit board (PCB). The thermal pad must be soldered directly to the PCB. After soldering, the PCB can be used as a heatsink. In addition, through the use of thermal vias, the thermal pad can be attached directly to the appropriate copper plane shown in the electrical schematic for the device, or alternatively, can be attached to a special heatsink structure designed into the PCB. This design optimizes the heat transfer from the integrated circuit (IC).

For additional information on the PowerPAD package and how to take advantage of its heat dissipating abilities, refer to Technical Brief, PowerPAD Thermally Enhanced Package, Texas Instruments Literature No. SLMA002 and Application Brief, PowerPAD Made Easy, Texas Instruments Literature No. SLMA004. Both documents are available at [www.ti.com](http://www.ti.com).

The exposed thermal pad dimensions for this package are shown in the following illustration.

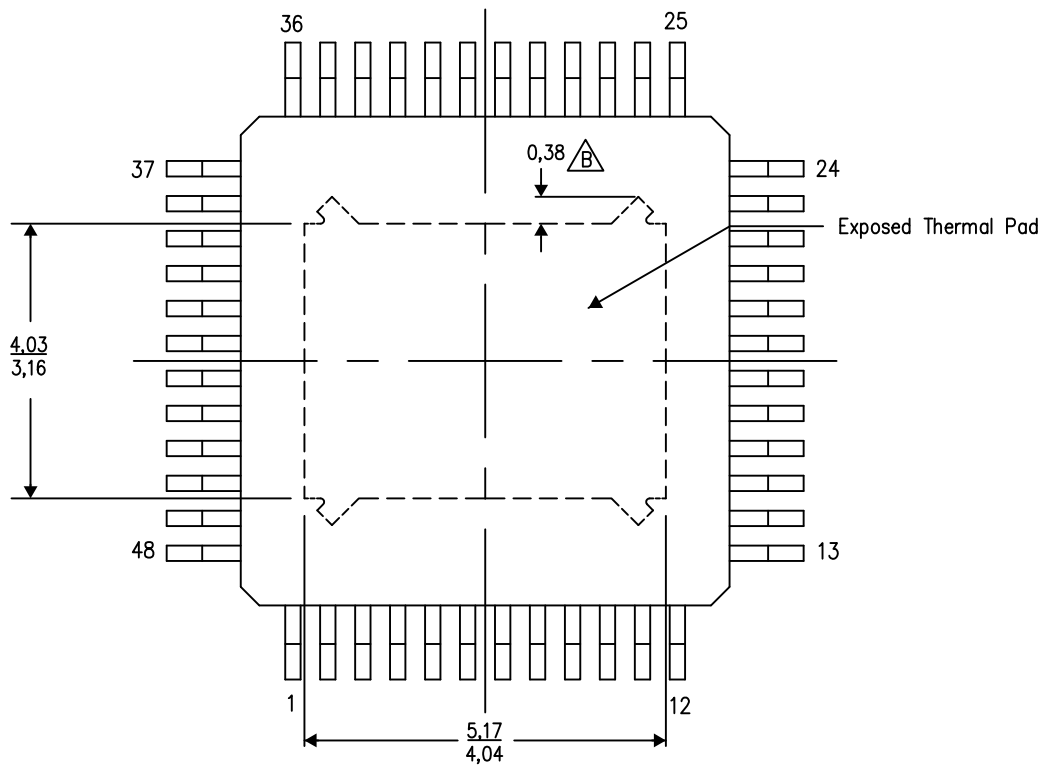

Exposed Thermal Pad Dimensions

4206329-18/P 03/15

NOTE: A. All linear dimensions are in millimeters

 Tie strap features may not be present.

PowerPAD is a trademark of Texas Instruments

PHP (S-PQFP-G48)

PowerPAD™ PLASTIC QUAD FLATPACK

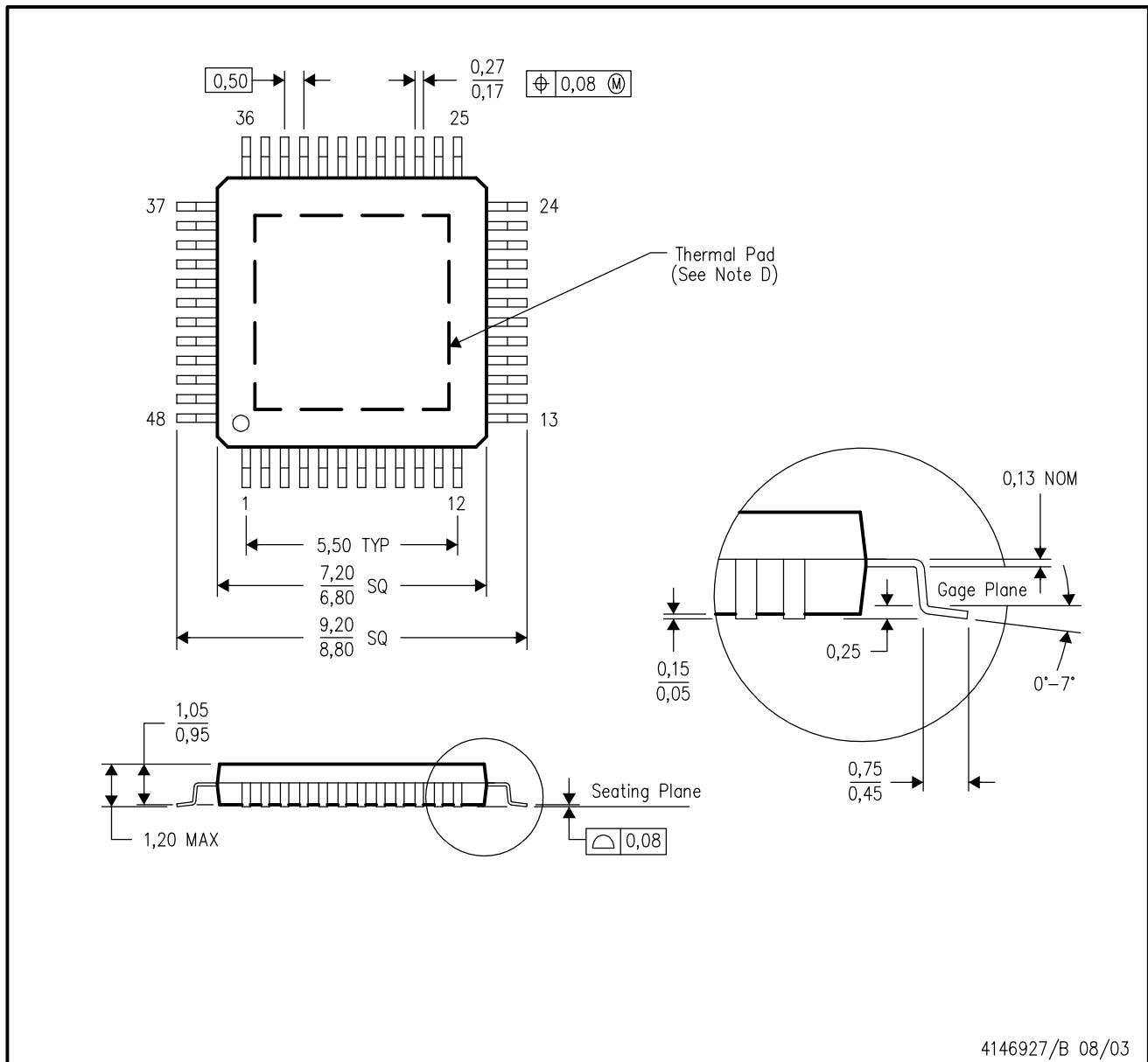

- NOTES:
- All linear dimensions are in millimeters.
  - This drawing is subject to change without notice.
  - Body dimensions do not include mold flash or protrusion.
  - This package is designed to be soldered to a thermal pad on the board. Refer to Technical Brief, PowerPad Thermally Enhanced Package, Texas Instruments Literature No. SLMA002 for information regarding recommended board layout. This document is available at [www.ti.com](http://www.ti.com) <<http://www.ti.com>>.
  - Falls within JEDEC MS-026

PowerPAD is a trademark of Texas Instruments.

# THERMAL PAD MECHANICAL DATA

PHP (S-PQFP-G48)

PowerPAD™ PLASTIC QUAD FLATPACK

## THERMAL INFORMATION

This PowerPAD™ package incorporates an exposed thermal pad that is designed to be attached to a printed circuit board (PCB). The thermal pad must be soldered directly to the PCB. After soldering, the PCB can be used as a heatsink. In addition, through the use of thermal vias, the thermal pad can be attached directly to the appropriate copper plane shown in the electrical schematic for the device, or alternatively, can be attached to a special heatsink structure designed into the PCB. This design optimizes the heat transfer from the integrated circuit (IC).

For additional information on the PowerPAD package and how to take advantage of its heat dissipating abilities, refer to Technical Brief, PowerPAD Thermally Enhanced Package, Texas Instruments Literature No. SLMA002 and Application Brief, PowerPAD Made Easy, Texas Instruments Literature No. SLMA004. Both documents are available at [www.ti.com](http://www.ti.com).

The exposed thermal pad dimensions for this package are shown in the following illustration.

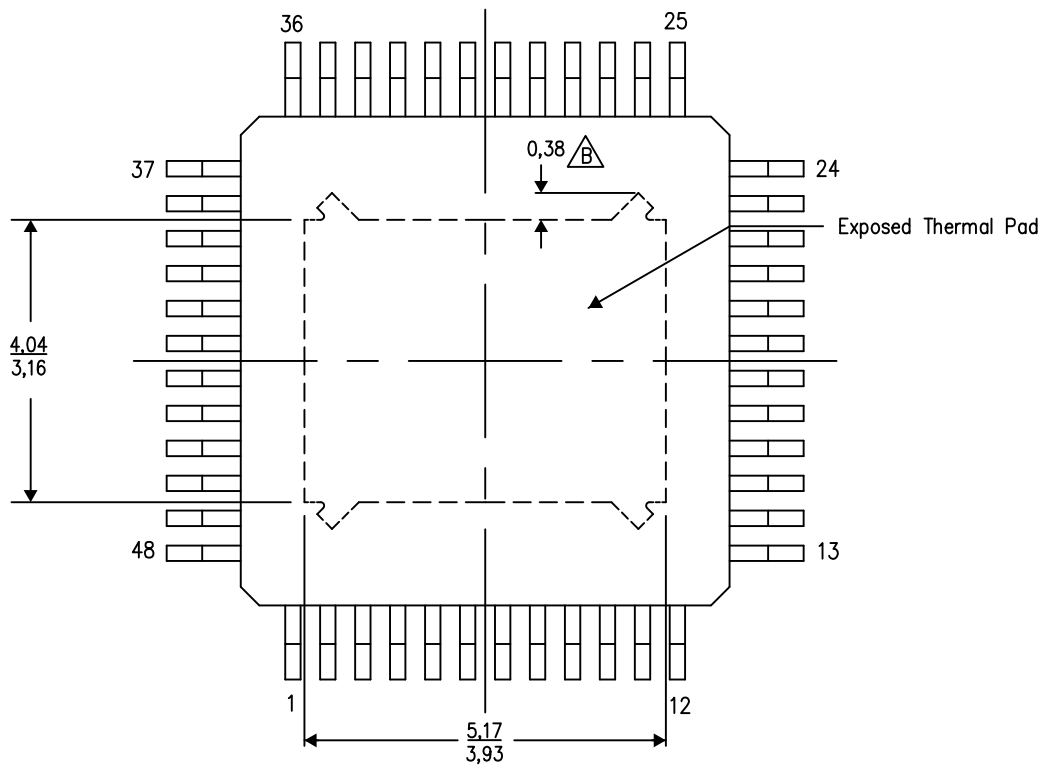

Top View

Exposed Thermal Pad Dimensions

4206329-9/P 03/15

NOTE: A. All linear dimensions are in millimeters

 Tie strap features may not be present.

PowerPAD is a trademark of Texas Instruments

PHP (S-PQFP-G48)

PowerPAD™ PLASTIC QUAD FLATPACK

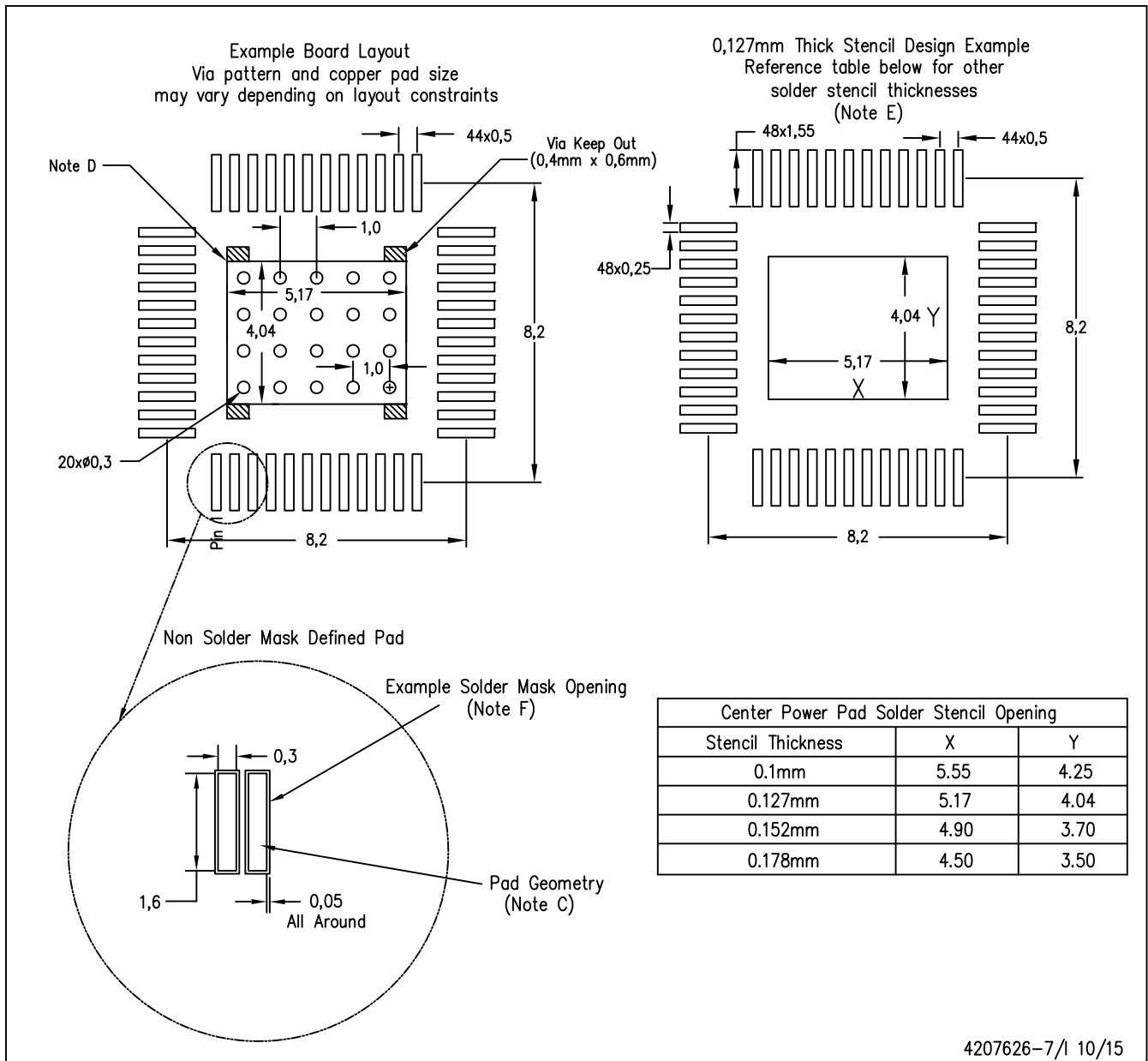

4207626-7/1 10/15

- NOTES:
- All linear dimensions are in millimeters.
  - This drawing is subject to change without notice.
  - Publication IPC-7351 is recommended for alternate designs.
  - This package is designed to be soldered to a thermal pad on the board. Refer to Technical Brief, PowerPAD Thermally Enhanced Package, Texas Instruments Literature No. SLMA002, SLMA004, and also the Product Data Sheets for specific thermal information, via requirements, and recommended board layout. These documents are available at [www.ti.com](http://www.ti.com) <<http://www.ti.com>>.
  - Laser cutting apertures with trapezoidal walls and also rounding corners will offer better paste release. Customers should contact their board assembly site for stencil design recommendations. Refer to IPC 7525 for stencil design considerations.
  - Customers should contact their board fabrication site for recommended solder mask tolerances and via tenting options for vias placed in the thermal pad.

PowerPAD is a trademark of Texas Instruments

## IMPORTANT NOTICE AND DISCLAIMER

TI PROVIDES TECHNICAL AND RELIABILITY DATA (INCLUDING DATA SHEETS), DESIGN RESOURCES (INCLUDING REFERENCE DESIGNS), APPLICATION OR OTHER DESIGN ADVICE, WEB TOOLS, SAFETY INFORMATION, AND OTHER RESOURCES "AS IS" AND WITH ALL FAULTS, AND DISCLAIMS ALL WARRANTIES, EXPRESS AND IMPLIED, INCLUDING WITHOUT LIMITATION ANY IMPLIED WARRANTIES OF MERCHANTABILITY, FITNESS FOR A PARTICULAR PURPOSE OR NON-INFRINGEMENT OF THIRD PARTY INTELLECTUAL PROPERTY RIGHTS.

These resources are intended for skilled developers designing with TI products. You are solely responsible for (1) selecting the appropriate TI products for your application, (2) designing, validating and testing your application, and (3) ensuring your application meets applicable standards, and any other safety, security, regulatory or other requirements.

These resources are subject to change without notice. TI grants you permission to use these resources only for development of an application that uses the TI products described in the resource. Other reproduction and display of these resources is prohibited. No license is granted to any other TI intellectual property right or to any third party intellectual property right. TI disclaims responsibility for, and you will fully indemnify TI and its representatives against, any claims, damages, costs, losses, and liabilities arising out of your use of these resources.

TI's products are provided subject to [TI's Terms of Sale](#) or other applicable terms available either on [ti.com](https://www.ti.com) or provided in conjunction with such TI products. TI's provision of these resources does not expand or otherwise alter TI's applicable warranties or warranty disclaimers for TI products.

TI objects to and rejects any additional or different terms you may have proposed.

Mailing Address: Texas Instruments, Post Office Box 655303, Dallas, Texas 75265  
Copyright © 2023, Texas Instruments Incorporated

## Looking for pricing, stock, or lifecycle information?

Click below to explore more details on WIN SOURCE:

 [View TAS5731EVM on WIN SOURCE](#)

 [Texas Instruments](#) Information

## Optimize Your Supply Chain with WIN SOURCE Solutions

-  Global Sourcing Solution
-  Obsolete Management
-  Cost Control Management
-  Shortage Management
-  Alternative Solution
-  Excess Inventory Management