



**THE DATASHEET OF
TAS5631DKDR**



300-W STEREO / 600-W MONO PurePath™ HD DIGITAL-INPUT POWER STAGE

 Check for Samples: [TAS5631](#)

FEATURES

- **PurePath™ HD Enabled Integrated Feedback Provides:**
 - Signal Bandwidth up to 80 kHz for High-Frequency Content From HD Sources
 - Ultralow 0.03% THD at 1 W Into 4 Ω
 - Flat THD at All Frequencies for Natural Sound
 - 80-dB PSRR (BTL, No Input Signal)
 - >100-dB (A-weighted) SNR
 - Click- and Pop-Free Start-Up
- **Multiple Configurations Possible on the Same PCB With Stuffing Options:**
 - Mono Parallel Bridge-Tied Load (PBTL)
 - Stereo Bridge-Tied Load (BTL)
 - 2.1 Single-Ended Stereo Pair and Bridge-Tied Load Subwoofer
 - Quad Single-Ended Outputs
- **Total Output Power at 10% THD+N**
 - 600 W in Mono PBTL Configuration
 - 300 W per Channel in Stereo BTL Configuration
 - 145 W per Channel in Quad Single-Ended Configuration
- **High-Efficiency Power Stage (>88%) With 60-mΩ Output MOSFETs**
- **Two Thermally Enhanced Package Options:**
 - PHD (64-Pin QFP)
 - DKD (44-Pin PSOP3)
- **Self-Protection Design (Including Undervoltage, Overtemperature, Clipping, and Short-Circuit Protection) With Error Reporting**
- **EMI Compliant When Used With Recommended System Design**

APPLICATIONS

- Mini Combo System
- AV Receivers
- DVD Receivers
- Active Speakers

DESCRIPTION

The TAS5631 is a high-performance PWM input class-D amplifier with integrated closed-loop feedback technology (known as PurePath HD technology) with the ability to drive up to 300 W ⁽¹⁾ stereo into 4-Ω to 8-Ω speakers from a single 50-V supply.

PurePath HD technology enables traditional AB-amplifier performance (<0.03% THD) levels while providing the power efficiency of traditional class-D amplifiers.

Unlike traditional class-D amplifiers, the distortion curve only increases once the output levels move into clipping.

PurePath HD technology enables lower idle losses, making the device even more efficient.

Note 1. Achievable output power levels are dependent on the thermal configuration of the target application. A high-performance thermal interface material between the package exposed heat slug and the heat sink should be used to achieve high output-power levels.

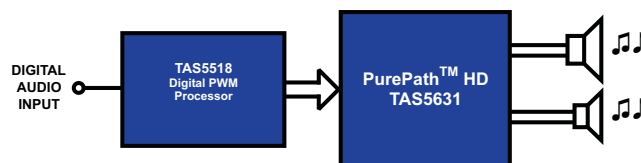

Please be aware that an important notice concerning availability, standard warranty, and use in critical applications of Texas Instruments semiconductor products and disclaimers thereto appears at the end of this data sheet.

PurePath HD is a trademark of Texas Instruments.
All other trademarks are the property of their respective owners.



These devices have limited built-in ESD protection. The leads should be shorted together or the device placed in conductive foam during storage or handling to prevent electrostatic damage to the MOS gates.

DEVICE INFORMATION

Terminal Assignment

Both package types contains a heat slug that is located on the top side of the device for convenient thermal coupling to the heat sink.

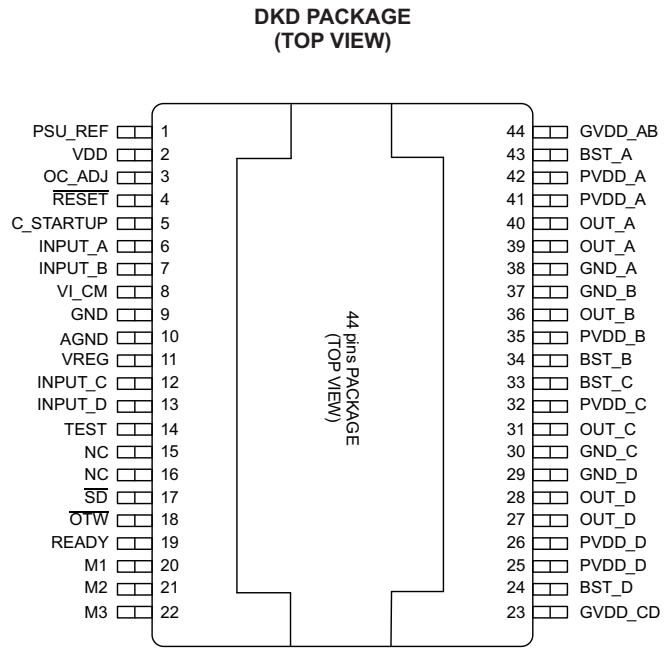
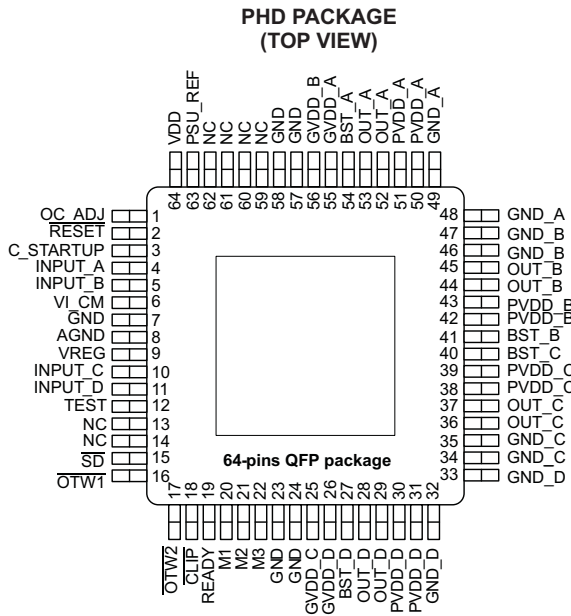

PIN ONE LOCATION PHD PACKAGE

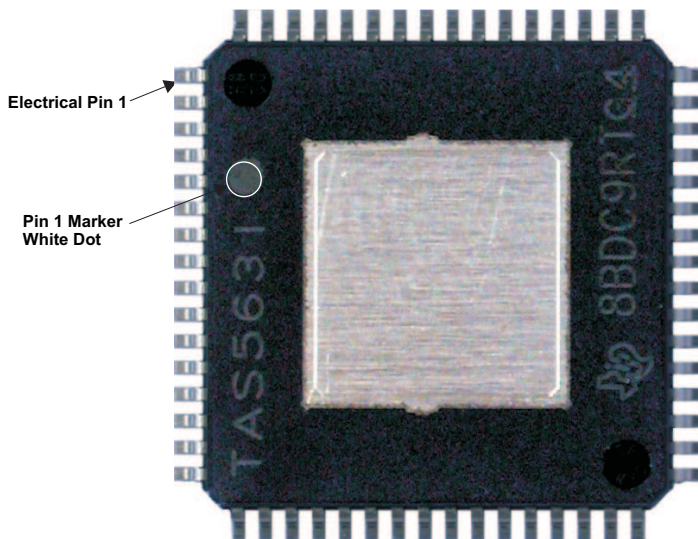

MODE SELECTION PINS

MODE PINS			PWM INPUT ⁽¹⁾	OUTPUT CONFIGURATION	DESCRIPTION		
M3	M2	M1					
0	0	0	2N	2 × BTL	AD mode		
0	0	1	—	—	Reserved		
0	1	0	2N	2 × BTL	BD mode		
0	1	1	1N	1 × BTL +2 × SE	AD mode		
1	0	0	1N	4 × SE	AD mode		
1	0	1	2N 1N	1 × PBTL	INPUT_C⁽²⁾	INPUT_D⁽²⁾	
					0	0	AD mode
					1	0	BD mode
1	1	0	Reserved				
1	1	1					

- (1) The 1N and 2N naming convention is used to indicate the number of PWM lines to the power stage per channel in a specific mode.
 (2) INPUT_C and INPUT_D are used to select between a subset of AD and BD mode operations in PBTL mode.

PACKAGE HEAT DISSIPATION RATINGS⁽¹⁾

PARAMETER	TAS5631PHD	TAS5631DKD
$R_{\theta JC}$ (°C/W) – 2 BTL or 4 SE channels	2.63	14
$R_{\theta JC}$ (°C/W) – 1 BTL or 2 SE channel(s)	4.13	2.04
$R_{\theta JC}$ (°C/W) – 1 SE channel	6.45	3.45
Pad area ⁽²⁾	64 mm ²	80 mm ²

- (1) $R_{\theta JC}$ is junction-to-case; $R_{\theta CH}$ is case-to-heatsink.
 (2) $R_{\theta CH}$ is an important consideration. Assume a 2-mil (0.051-mm) thickness of thermal grease with a thermal conductivity of 2.5 W/mK between the pad area and the heat sink and both channels active. The $R_{\theta CH}$ with this condition is 1.1°C/W for the PHD package and 0.44°C/W for the DKD package.

Table 1. ORDERING INFORMATION⁽¹⁾

T _A	PACKAGE	DESCRIPTION
0°C–70°C	TAS5631PHD	64-pin HTQFP
0°C–70°C	TAS5631DKD	44-pin PSOP3

- (1) For the most current package and ordering information, see the Package Option Addendum at the end of this document, or see the TI Web site at www.ti.com.

ABSOLUTE MAXIMUM RATINGS

over operating free-air temperature range unless otherwise noted ⁽¹⁾

TAS5631		UNIT	
VDD to AGND	-0.3 to 13.2	V	
GVDD to AGND	-0.3 to 13.2	V	
PVDD_X to GND_X ⁽²⁾	-0.3 to 69	V	
OUT_X to GND_X ⁽²⁾	-0.3 to 69	V	
BST_X to GND_X ⁽²⁾	-0.3 to 82.2	V	
BST_X to GVDD_X ⁽²⁾	-0.3 to 69	V	
VREG to AGND	-0.3 to 4.2	V	
GND_X to GND	-0.3 to 0.3	V	
GND_X to AGND	-0.3 to 0.3	V	
GND to AGND	-0.3 to 0.3	V	
INPUT_X, OC_ADJ, M1, M2, M3, OSC_IO+, OSC_IO-, FREQ_ADJ, VI_CM, C_STARTUP, PSU_REF to AGND	-0.3 to 4.2	V	
RESET, SD, OTW1, OTW2, CLIP, READY to AGND	-0.3 to 7	V	
Maximum continuous sink current (SD, OTW1, OTW2, CLIP, READY)	9	mA	
Maximum operating junction temperature range, T _J	0 to 150	°C	
Storage temperature, T _{stg}	-40 to 150	°C	
Electrostatic discharge	Human-body model ⁽³⁾ (all pins)	±2	kV
	Charged-device model ⁽³⁾ (all pins)	±500	V

- (1) Stresses beyond those listed under *Absolute Maximum Ratings* may cause permanent damage to the device. These are stress ratings only, and functional operation of the device at these or any other conditions beyond those indicated under *Recommended Operating Conditions* is not implied. Exposure to absolute-maximum-rated conditions for extended periods may affect device reliability.
- (2) These voltages represents the dc voltage + peak ac waveform measured at the terminal of the device in all conditions.
- (3) Failure to follow good anti-static ESD handling during manufacture and rework contributes to device malfunction. Make sure the operators handling the device are adequately grounded through the use of ground straps or alternative ESD protection.

RECOMMENDED OPERATING CONDITIONS

over operating free-air temperature range (unless otherwise noted)

			MIN	NOM	MAX	UNIT
PVDD_x	Half-bridge supply	DC supply voltage	25	50	52.5	V
GVDD_x	Supply for logic regulators and gate-drive circuitry	DC supply voltage	10.8	12	13.2	V
VDD	Digital regulator supply voltage	DC supply voltage	10.8	12	13.2	V
R _L (BTL)	Load impedance	Output filter according to schematics in the application information section.	3.5	4		Ω
R _L (SE)			1.8	2		
R _L (PBTL)			1.6	2		
L _{OUTPUT} (BTL)	Output filter inductance	Minimum output inductance at I _{OC}	7	10		μH
L _{OUTPUT} (SE)			7	15		
L _{OUTPUT} (PBTL)			7	10		
f _{PWM}	PWM frame rate		352	384	500	kHz
T _J	Junction temperature		0		150	°C

TERMINAL FUNCTIONS

TERMINAL			Function ⁽¹⁾	DESCRIPTION
NAME	PHD NO.	DKD NO.		
AGND	8	10	P	Analog ground
BST_A	54	43	P	HS bootstrap supply (BST); external 0.033-μF capacitor to OUT_A required
BST_B	41	34	P	HS bootstrap supply (BST); external 0.033-μF capacitor to OUT_B required

(1) I = Input, O = Output, P = Power

TERMINAL FUNCTIONS (continued)

TERMINAL			Function ⁽¹⁾	DESCRIPTION
NAME	PHD NO.	DKD NO.		
BST_C	40	33	P	HS bootstrap supply (BST); external 0.033- μ F capacitor to OUT_C required
BST_D	27	24	P	HS bootstrap supply (BST); external 0.033- μ F capacitor to OUT_D required
$\overline{\text{CLIP}}$	18	—	O	Clipping warning; open drain; active-low
C_STARTUP	3	5	O	Start-up ramp requires a charging capacitor of 4.7 nF to AGND.
TEST	12	14	I	Connect to VREG node
GND	7, 23, 24, 57, 58	9	P	Ground
GND_A	48, 49	38	P	Power ground for half-bridge A
GND_B	46, 47	37	P	Power ground for half-bridge B
GND_C	34, 35	30	P	Power ground for half-bridge C
GND_D	32, 33	29	P	Power ground for half-bridge D
GVDD_A	55	—	P	Gate drive voltage supply requires 0.1- μ F capacitor to AGND.
GVDD_B	56	—	P	Gate drive voltage supply requires 0.1- μ F capacitor to AGND.
GVDD_C	25	—	P	Gate drive voltage supply requires 0.1- μ F capacitor to AGND.
GVDD_D	26	—	P	Gate drive voltage supply requires 0.1- μ F capacitor to AGND.
GVDD_AB	—	44	P	Gate drive voltage supply requires 0.22- μ F capacitor to AGND.
GVDD_CD	—	23	P	Gate drive voltage supply requires 0.22- μ F capacitor to AGND.
INPUT_A	4	6	I	Input signal for half-bridge A
INPUT_B	5	7	I	Input signal for half-bridge B
INPUT_C	10	12	I	Input signal for half-bridge C
INPUT_D	11	13	I	Input signal for half-bridge D
M1	20	20	I	Mode selection
M2	21	21	I	Mode selection
M3	22	22	I	Mode selection
NC	59–62	—	—	No connect; pins may be grounded.
NC	13, 14	15, 16	—	No connect; pins may be grounded.
OC_ADJ	1	3	O	Analog overcurrent programming pin requires resistor to ground.
$\overline{\text{OTW}}$	—	18	O	Overtemperature warning signal, open-drain, active-low
$\overline{\text{OTW1}}$	16	—	O	Overtemperature warning signal, open-drain, active-low
$\overline{\text{OTW2}}$	17	—	O	Overtemperature warning signal, open-drain, active-low
OUT_A	52, 53	39, 40	O	Output, half-bridge A
OUT_B	44, 45	36	O	Output, half-bridge B
OUT_C	36, 37	31	O	Output, half-bridge C
OUT_D	28, 29	27, 28	O	Output, half-bridge D
PSU_REF	63	1	P	PSU reference requires close decoupling of 4.7 μ F to AGND.
PVDD_A	50, 51	41, 42	P	Power-supply input for half-bridge A requires close decoupling of 0.01- μ F capacitor in parallel with 1- μ F capacitor to GND_A.
PVDD_B	42, 43	35	P	Power-supply input for half-bridge B requires close decoupling of 0.01- μ F capacitor in parallel with 1- μ F capacitor to GND_B.
PVDD_C	38, 39	32	P	Power-supply input for half-bridge C requires close decoupling of 0.01- μ F capacitor in parallel with 1- μ F capacitor to GND_C.
PVDD_D	30, 31	25, 26	P	Power-supply input for half-bridge D requires close decoupling of 0.01- μ F capacitor in parallel with 1- μ F capacitor to GND_D.
READY	19	19	O	Normal operation; open-drain; active-high
$\overline{\text{RESET}}$	2	4	I	Device reset input; active-low
$\overline{\text{SD}}$	15	17	O	Shutdown signal; open-drain, active-low
VDD	64	2	P	Power supply for digital voltage regulator requires a 47- μ F capacitor in parallel with a 0.1- μ F capacitor to GND for decoupling.
VI_CM	6	8	O	Analog comparator reference node requires close decoupling of 4.7 μ F to AGND.
VREG	9	11	P	Digital regulator supply filter pin requires 0.1- μ F capacitor to AGND.

TYPICAL SYSTEM BLOCK DIAGRAM

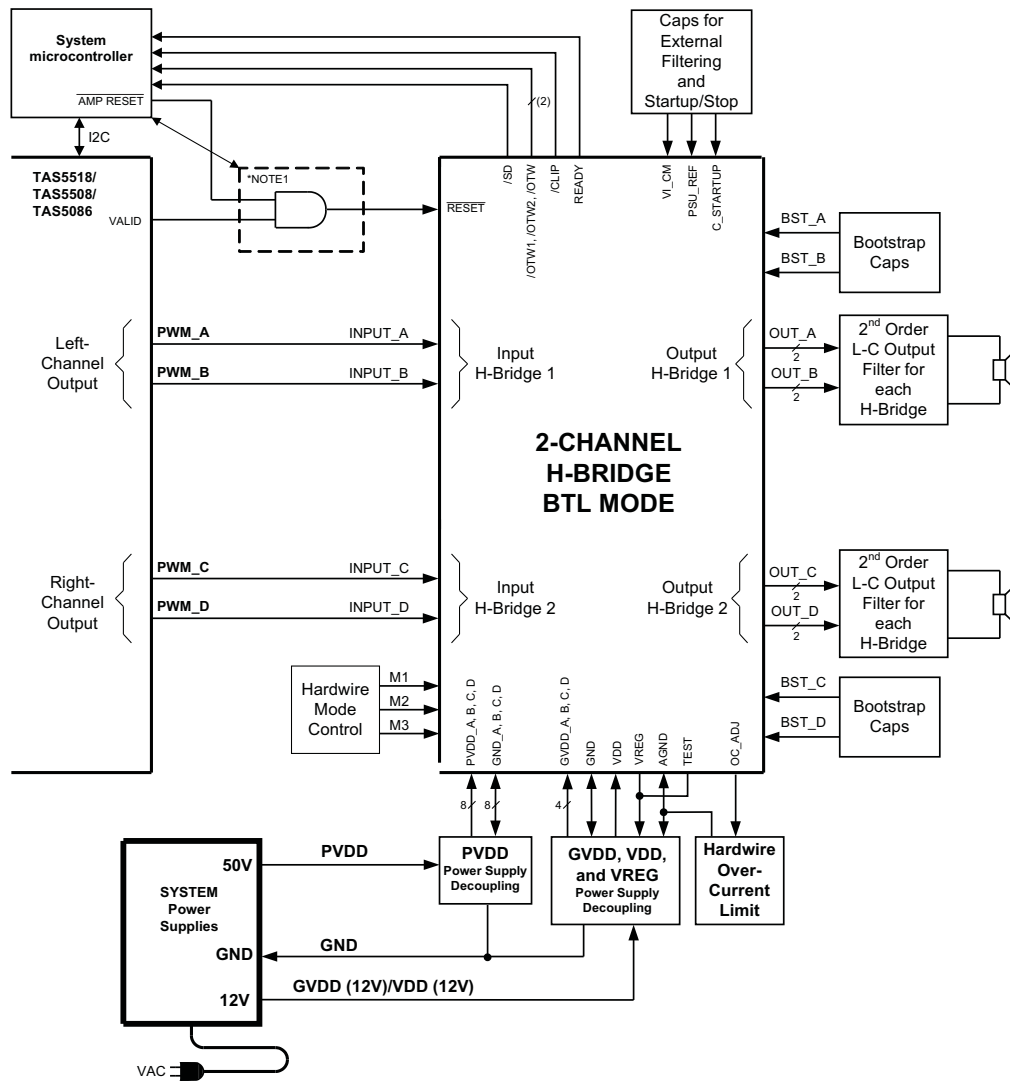

(1) Logic AND is inside or outside the microcontroller.

FUNCTIONAL BLOCK DIAGRAM

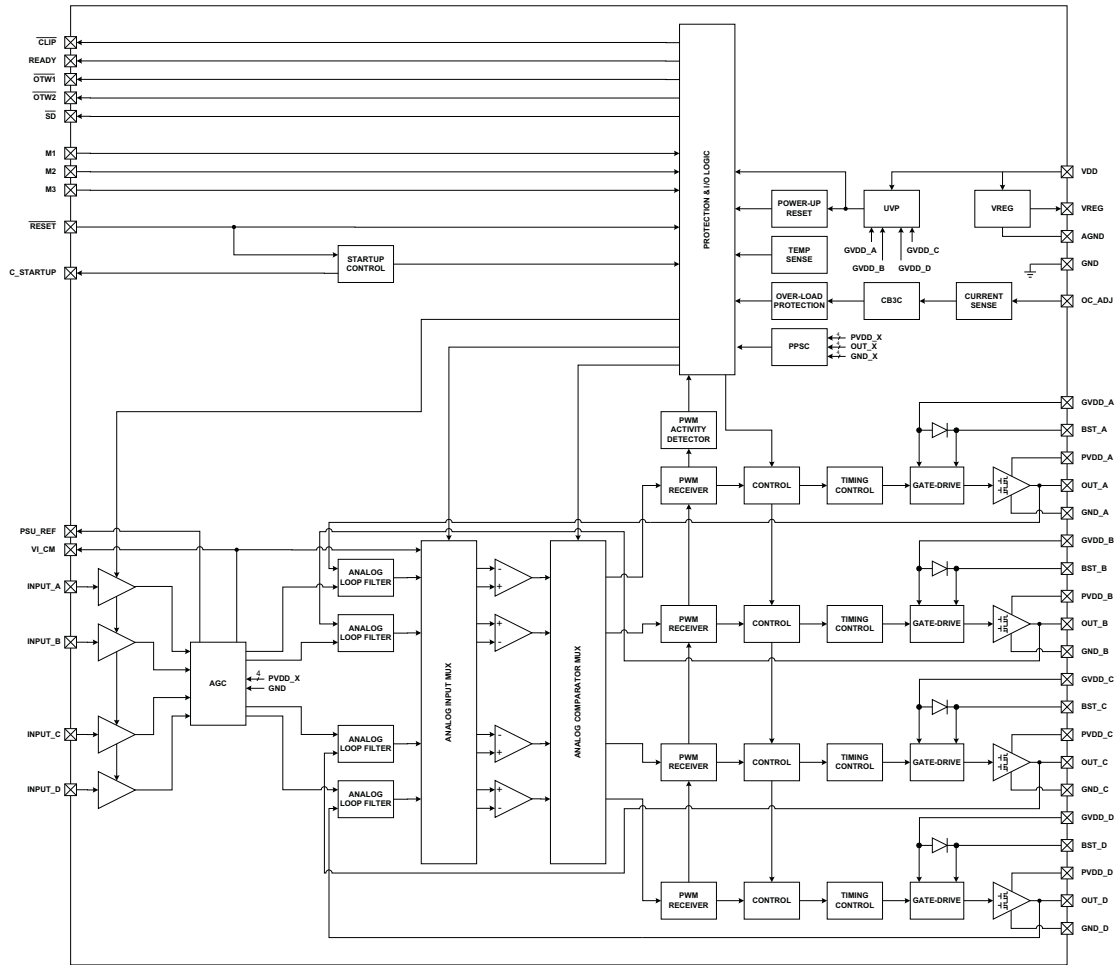

AUDIO CHARACTERISTICS (BTL)

Audio performance is recorded as a chipset consisting of a TAS5518 PWM processor (modulation index limited to 97.7%) and a TAS5631 power stage. PCB and system configurations are in accordance with recommended guidelines. Audio frequency = 1 kHz, PVDD_X = 50 V, GVDD_X = 12 V, R_L = 4 Ω, f_s = 384 kHz, R_{OC} = 22 kΩ, T_C = 75°C; output filter: L_{DEM} = 7 μH, C_{DEM} = 680 nF, MODE = 000, unless otherwise noted.

PARAMETER	TEST CONDITIONS	MIN	TYP	MAX	UNIT
P _O Power output per channel	R _L = 4 Ω, 10% THD+N, clipped input signal		300		W
	R _L = 6 Ω, 10% THD+N, clipped input signal		210		
	R _L = 8 Ω, 10% THD+N, clipped input signal		160		
	R _L = 4 Ω, 1% THD+N, unclipped input signal		240		
	R _L = 6 Ω, 1% THD+N, unclipped input signal		160		
	R _L = 8 Ω, 1% THD+N, unclipped input signal		125		
THD+N Total harmonic distortion + noise	1 W		0.03%		
V _n Output integrated noise	A-weighted, TAS5518 modulator		180		μV
V _{OS} Output offset voltage	No signal		40	150	mV
SNR Signal-to-noise ratio ⁽¹⁾	A-weighted, TAS5518 modulator		103		dB
DNR Dynamic range	A-weighted, input level –60 dBFS using TAS5518 modulator		103		dB
P _{idle} Power dissipation due to idle losses (I _{PVDD_X})	P _O = 0, four channels switching ⁽²⁾		3.9		W

(1) SNR is calculated relative to 1% THD-N output level.

(2) Actual system idle losses also are affected by core losses of output inductors.

AUDIO SPECIFICATION (Single-Ended Output)

Audio performance is recorded as a chipset consisting of a TAS5086 PWM processor (modulation index limited to 97.7%) and a TAS5631 power stage. PCB and system configurations are in accordance with recommended guidelines. Audio frequency = 1 kHz, PVDD_X = 50 V, GVDD_X = 12 V, R_L = 2 Ω, f_s = 384 kHz, R_{OC} = 22 kΩ, T_C = 75°C; output filter: L_{DEM} = 7 μH, C_{DEM} = 470 nF, MODE = 100, unless otherwise noted.

PARAMETER	TEST CONDITIONS	MIN	TYP	MAX	UNIT
P _O Power output per channel	R _L = 2 Ω, 10%, THD+N, clipped input signal		145		W
	R _L = 3 Ω, 10%, THD+N, clipped input signal		100		
	R _L = 4 Ω, 10%, THD+N, clipped input signal		75		
	R _L = 2 Ω, 1% THD+N, unclipped input signal		110		
	R _L = 3 Ω, 1% THD+N, unclipped input signal		75		
	R _L = 4 Ω, 1% THD+N, unclipped input signal		55		
THD+N Total harmonic distortion + noise	1 W		0.04%		
V _n Output integrated noise	A-weighted, TAS5086 modulator		140		μV
SNR Signal-to-noise ratio ⁽¹⁾	A-weighted, TAS5086 modulator		100		dB
DNR Dynamic range	A-weighted, input level –60 dBFS using TAS5086 modulator		100		dB
P _{idle} Power dissipation due to idle losses (I _{PVDD_X})	P _O = 0, 4 channels switching ⁽²⁾		3		W

(1) SNR is calculated relative to 1% THD-N output level.

(2) Actual system idle losses are affected by core losses of output inductors.

AUDIO SPECIFICATION (PBTL)

Audio performance is recorded as a chipset consisting of a TAS5518 PWM processor (modulation index limited to 97.7%) and a TAS5631 power stage. PCB and system configurations are in accordance with recommended guidelines. Audio frequency = 1 kHz, PVDD_X = 50 V, GVDD_X = 12 V, R_L = 2 Ω, f_s = 384 kHz, R_{OC} = 22 kΩ, T_C = 75°C; output filter: L_{DEM} = 7 μH, C_{DEM} = 1 μF, MODE = 101-00, unless otherwise noted.

PARAMETER		TEST CONDITIONS	MIN	TYP	MAX	UNIT
P _O	Power output per channel	R _L = 2 Ω, 10%, THD+N, clipped input signal		600		W
		R _L = 3 Ω, 10%, THD+N, clipped input signal		400		
		R _L = 4 Ω, 10%, THD+N, unclipped input signal		300		
		R _L = 2 Ω, 1% THD+N, unclipped input signal		480		
		R _L = 3 Ω, 1% THD+N, unclipped input signal		310		
		R _L = 4 Ω, 1% THD+N, unclipped input signal		230		
THD+N	Total harmonic distortion + noise	1 W		0.03%		
V _n	Output integrated noise	A-weighted, TAS5518 modulator		170		μV
SNR	Signal-to-noise ratio ⁽¹⁾	A-weighted, TAS5518 modulator		103		dB
DNR	Dynamic range	A-weighted, input level –60 dBFS using TAS5518 modulator		103		dB
P _{idle}	Power dissipation due to idle losses (I _{PVDD_X})	P _O = 0, 4 channels switching ⁽²⁾		3.7		W

(1) SNR is calculated relative to 1% THD-N output level.

(2) Actual system idle losses are affected by core losses of output inductors.

ELECTRICAL CHARACTERISTICS

PVDD_X = 50V, GVDD_X = 12 V, VDD = 12V, T_C (case temperature) = 75°C, f_s = 384 kHz, unless otherwise specified.

PARAMETER		TEST CONDITIONS	MIN	TYP	MAX	UNIT
INTERNAL VOLTAGE REGULATOR AND CURRENT CONSUMPTION						
VREG	Voltage regulator, only used as reference node, VREG	VDD = 12 V	3	3.3	3.6	V
VI_CM	Analog comparator reference node, VI_CM		1.5	1.75	1.9	V
I _{VDD}	VDD supply current	Operating, 50% duty cycle		22.5		mA
		Idle, reset mode		22.5		
I _{GVDD_x}	Gate-supply current per half-bridge	50% duty cycle		12.5		mA
		Reset mode		1.5		
I _{PVDD_x}	Half-bridge idle current	50% duty cycle without output filter or load		19.5		mA
		Reset mode, no switching		750		
OUTPUT-STAGE MOSFETS						
R _{DS(on)}	Drain-to-source resistance, low side (LS)	T _J = 25°C, excludes metallization resistance, GVDD = 12 V		60	100	mΩ
	Drain-to-source resistance, high side (HS)			60	100	mΩ

ELECTRICAL CHARACTERISTICS (continued)

PVDD_X = 50V, GVDD_X = 12 V, VDD = 12V, T_C (case temperature) = 75°C, f_s = 384 kHz, unless otherwise specified.

PARAMETER		TEST CONDITIONS	MIN	TYP	MAX	UNIT
I/O PROTECTION						
V _{uvp,G}	Undervoltage protection limit, GVDD_X			10		V
V _{uvp,hyst} ⁽¹⁾				0.6		V
OTW1 ⁽¹⁾	Overtemperature warning 1		95	100	105	°C
OTW2 ⁽¹⁾	Overtemperature warning 2		115	125	135	°C
OTW _{hyst} ⁽¹⁾	Temperature drop needed below OTW temperature for OTW to be inactive after OTW event			25		°C
OTE ⁽¹⁾	Overtemperature error		145	155	165	°C
	OTE-OTW differential			30		°C
OTE _{HYST} ⁽¹⁾	A reset must occur for \overline{SD} to be released following an OTE event			25		°C
OLPC	Overload protection counter	f _{PWM} = 384 kHz		2.6		ms
I _{OC}	Overcurrent limit response	Resistor – programmable, nominal peak current in 1-Ω load, 64-pin QFP package (PHD) R _{OCP} = 22 kΩ		19		A
		Resistor – programmable, nominal peak current in 1-Ω load, 44-pin PSOP3 package (DKD) R _{OCP} = 24 kΩ		19		A
	Overcurrent response time, latched	Resistor – programmable, nominal peak current in 1-Ω load, R _{OCP} = 47 kΩ		19		A
I _{OCT}	Overcurrent response time	Time from application of short condition to Hi-Z of affected half-bridge		150		ns
I _{PD}	Internal pulldown resistor at output of each half-bridge	Connected when \overline{RESET} is active to provide bootstrap charge. Not used in SE mode.		3		mA
STATIC DIGITAL SPECIFICATIONS						
V _{IH}	High-level input voltage	INPUT_X, M1, M2, M3, RESET	1.9			V
V _{IL}	Low-level input voltage				1.45	V
I _{ikg}	Input leakage current				100	μA
OTW/SHUTDOWN (SD)						
R _{INT_PU}	Internal pullup resistance, $\overline{OTW1}$ to VREG, $\overline{OTW2}$ to VREG, \overline{SD} to VREG		20	26	33	kΩ
V _{OH}	High-level output voltage	Internal pullup resistor	3	3.3	3.6	V
		External pullup of 4.7 kΩ to 5 V	4.5		5	
V _{OL}	Low-level output voltage	I _O = 4 mA		200	500	mV
FANOUT	Device fanout $\overline{OTW1}$, $\overline{OTW2}$, \overline{SD} , \overline{CLIP} , \overline{READY}	No external pullup		30		devices

(1) Specified by design

TYPICAL CHARACTERISTICS, BTL CONFIGURATION

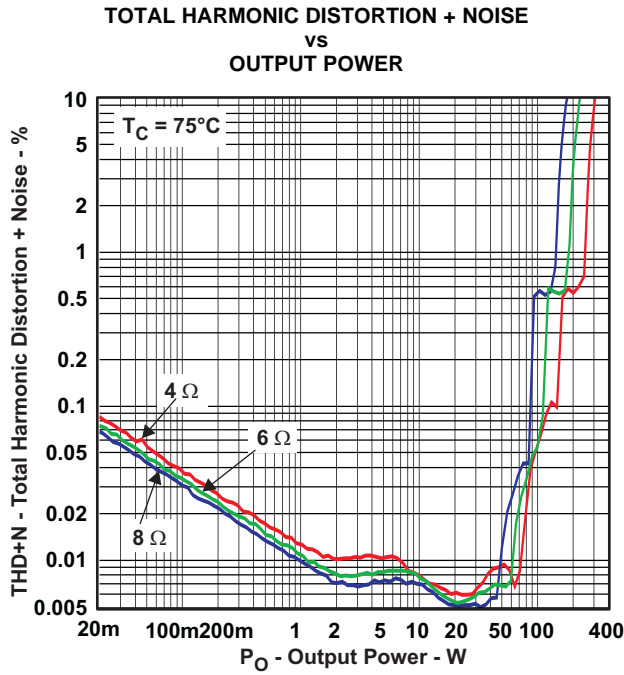

Figure 1.

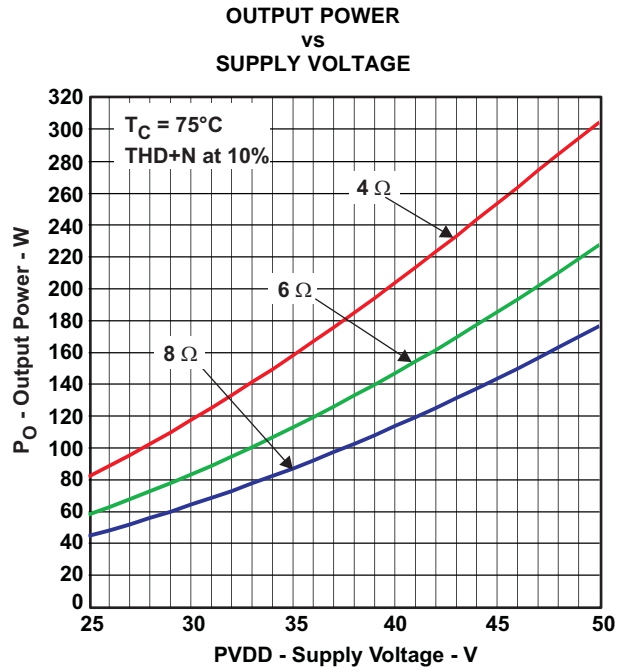

Figure 2.

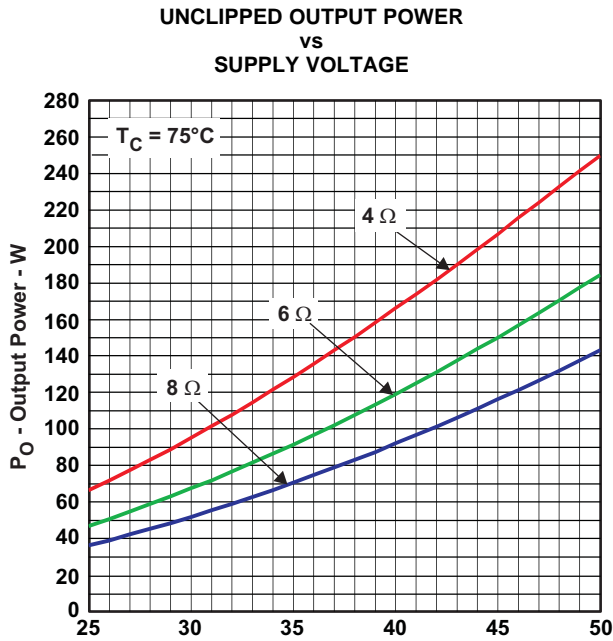

Figure 3.

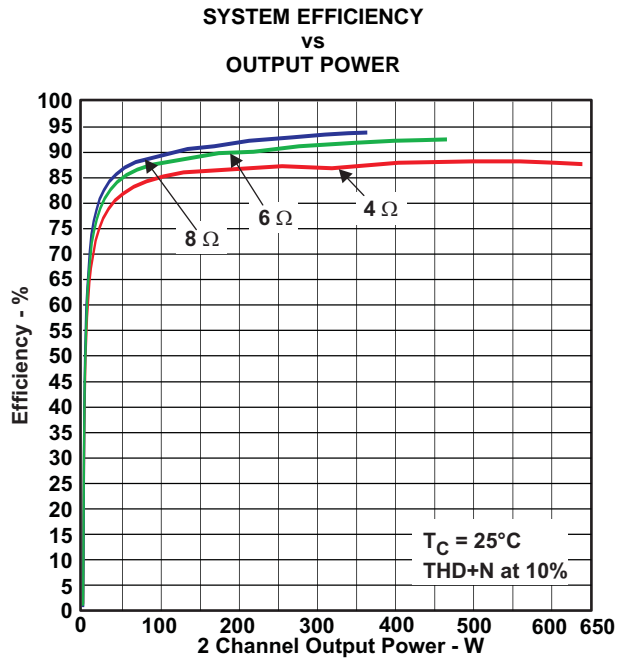

Figure 4.

TYPICAL CHARACTERISTICS, BTL CONFIGURATION (continued)

**SYSTEMS POWER LOSS
VS
OUTPUT POWER**

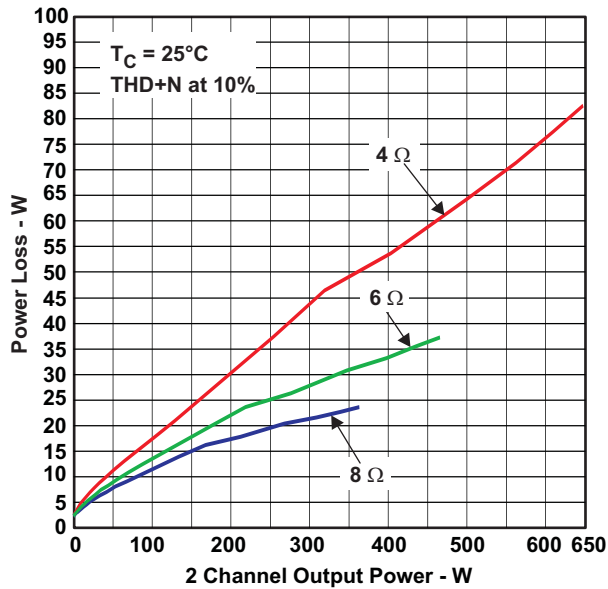

Figure 5.

**OUTPUT POWER
VS
CASE TEMPERATURE**

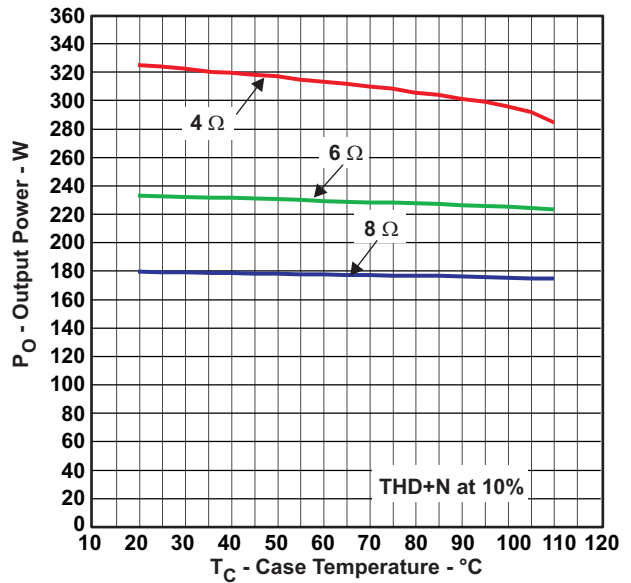

Figure 6.

**NOISE AMPLITUDE
VS
FREQUENCY**

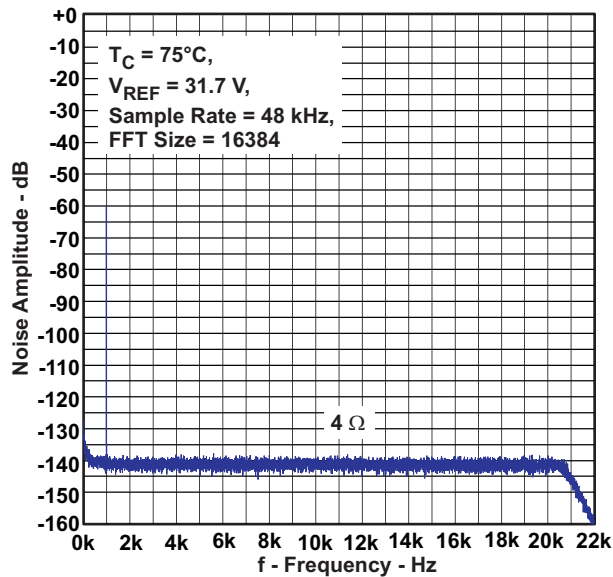

Figure 7.

TYPICAL CHARACTERISTICS, SE CONFIGURATION

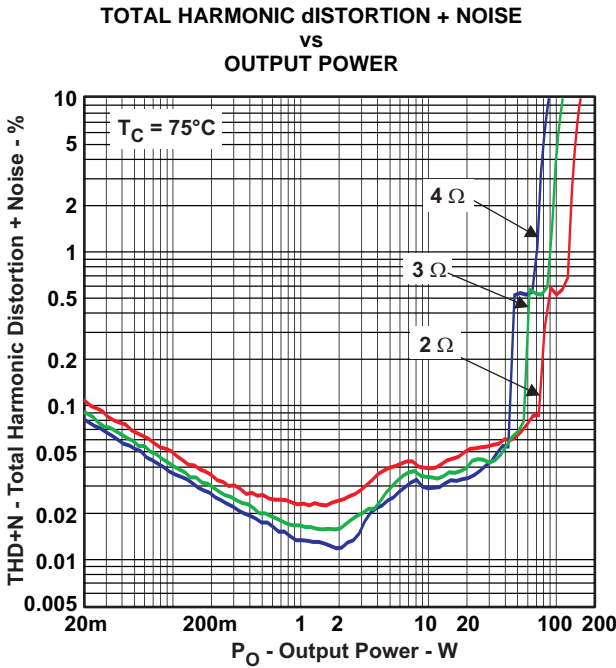

Figure 8.

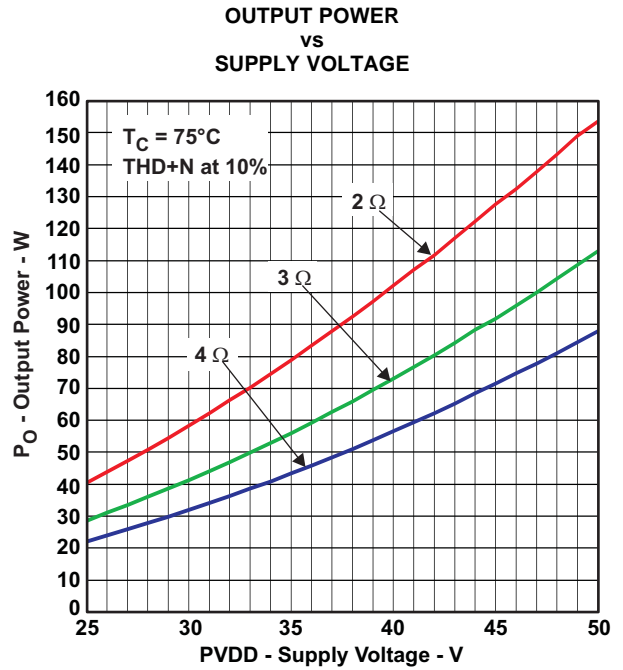

Figure 9.

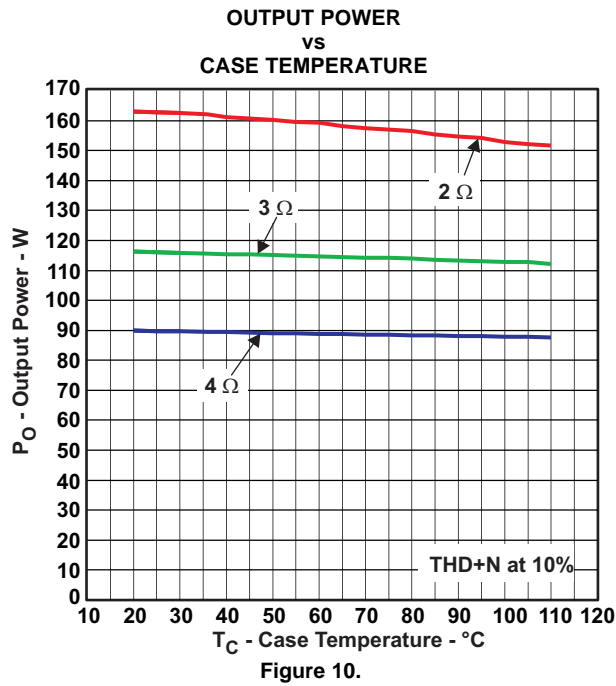

Figure 10.

TYPICAL CHARACTERISTICS, PBTL CONFIGURATION

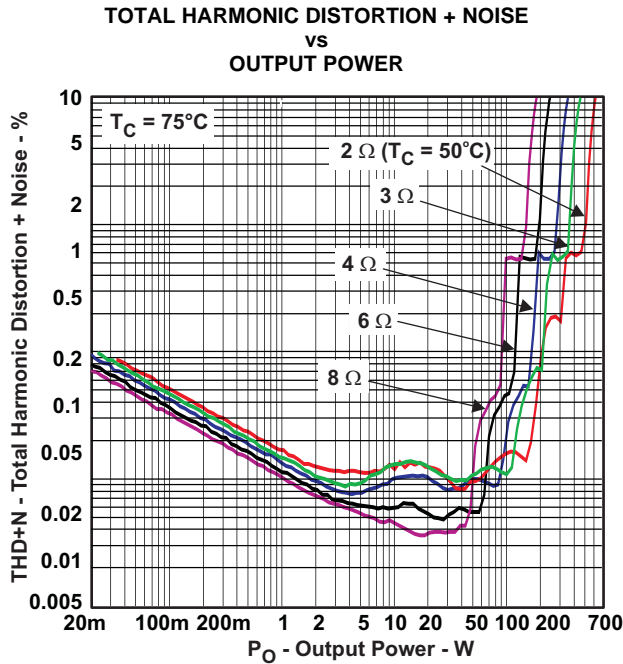

Figure 11.

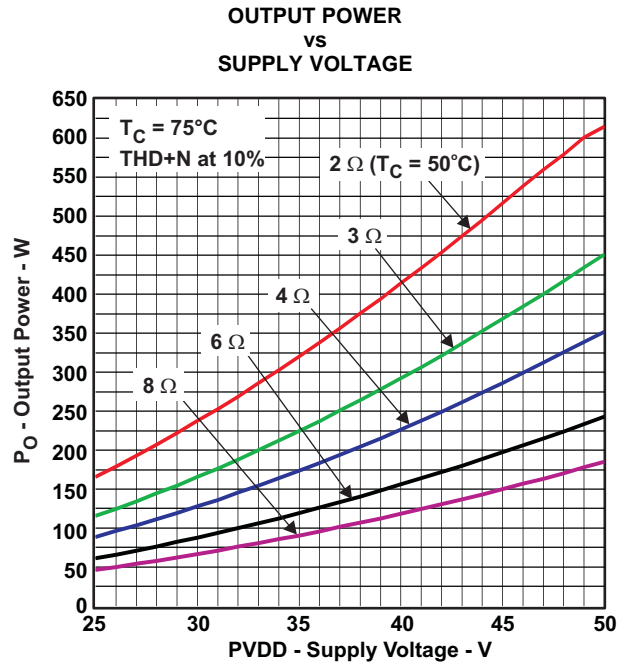

Figure 12.

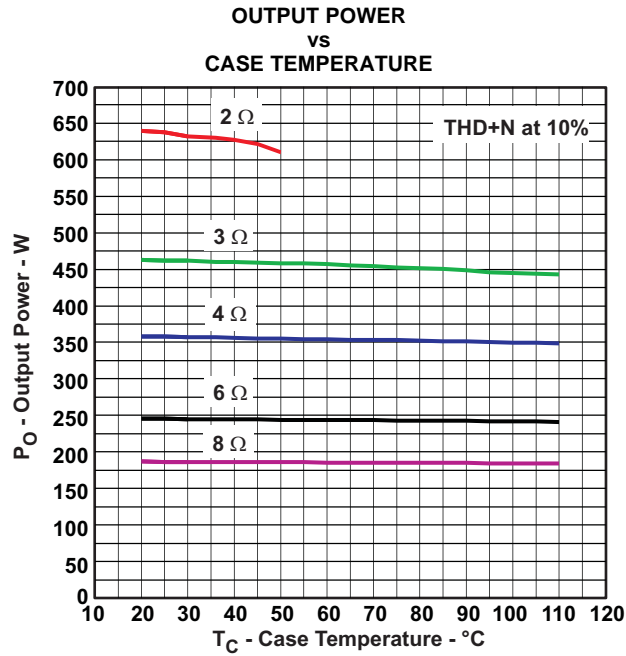

Figure 13.

APPLICATION INFORMATION

PCB MATERIAL RECOMMENDATION

FR-4 2-oz. (70 μm) glass epoxy material is recommended for use with the TAS5631. The use of this material can provide for higher power output, improved thermal performance, and better EMI margin (due to lower PCB trace inductance).

PVDD CAPACITOR RECOMMENDATION

The large capacitors used in conjunction with each full bridge are referred to as the PVDD capacitors. These capacitors should be selected for proper voltage margin and adequate capacitance to support the power requirements. In practice, with a well-designed system power supply, 1000 μF , 63 V support more applications. The PVDD capacitors should be the low-ESR type because they are used in a circuit associated with high-speed switching.

DECOUPLING CAPACITOR RECOMMENDATION

To design an amplifier that has robust performance, passes regulatory requirements, and exhibits good audio performance, good-quality decoupling capacitors should be used. In practice, X7R should be used in this application.

The voltage of the decoupling capacitors should be selected in accordance with good design practices. Temperature, ripple current, and voltage overshoot must be considered. This fact is particularly true in the selection of the 0.1- μF capacitor that is placed on the power supply to each half-bridge. It must withstand the voltage overshoot of the PWM switching, the heat generated by the amplifier during high power output, and the ripple current created by high power output. A minimum voltage rating of 63 V is required for use with a 50-V power supply.

SYSTEM DESIGN RECOMMENDATIONS

The following schematics and PCB layouts illustrate *best practices* in the use of the TAS5631.

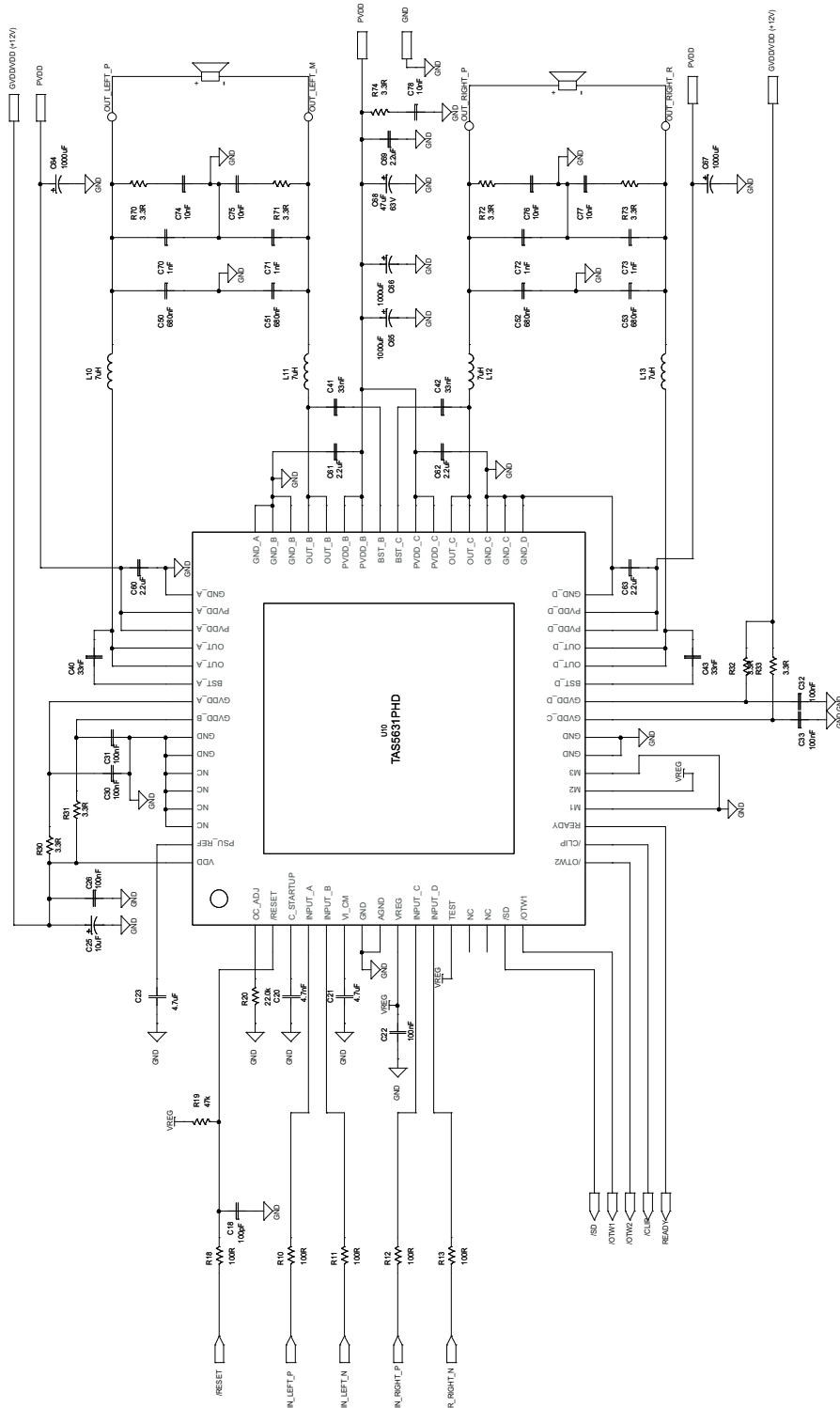

Figure 14. Typical Differential (2N) BTL Application With BD Modulation Filters

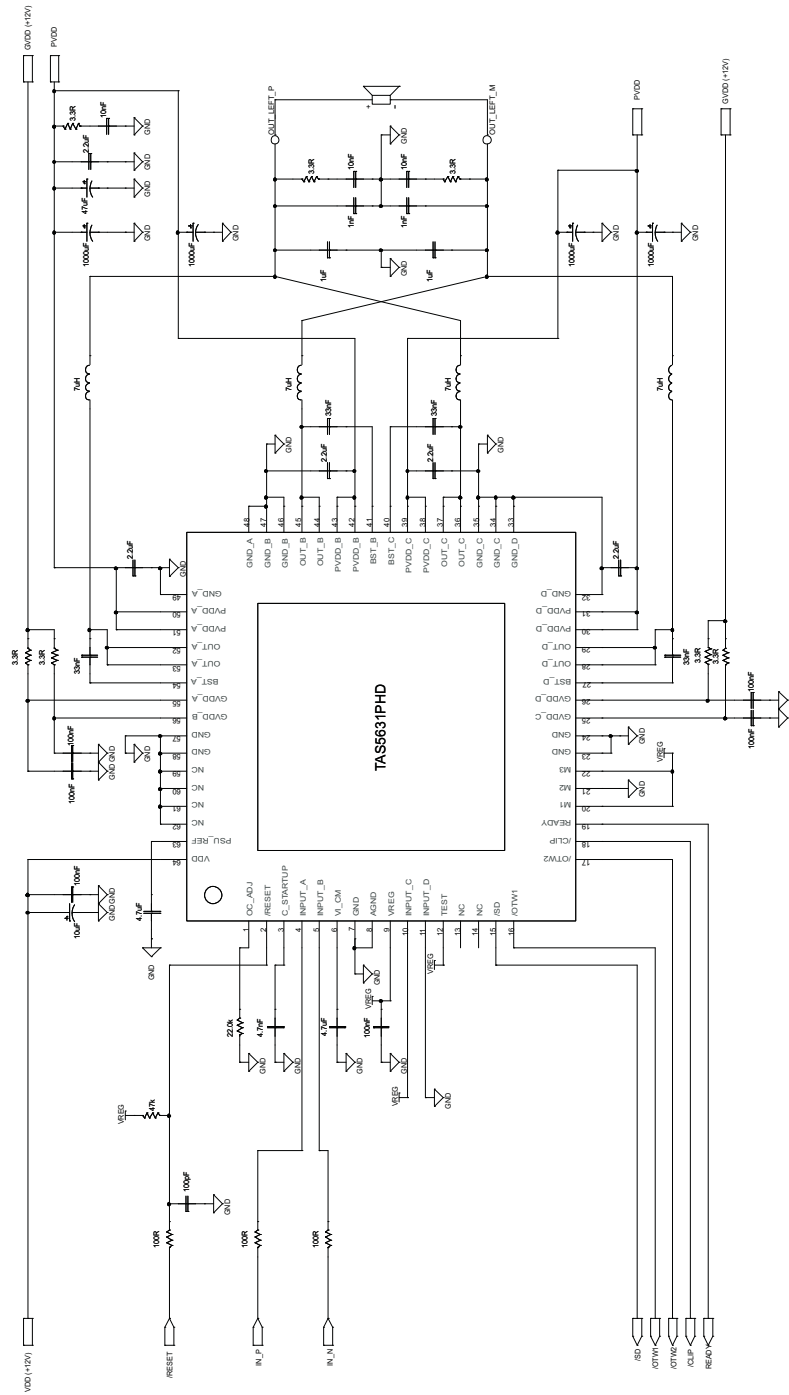

Figure 15. Typical (2N) PBTL Application With AD Modulation Filters

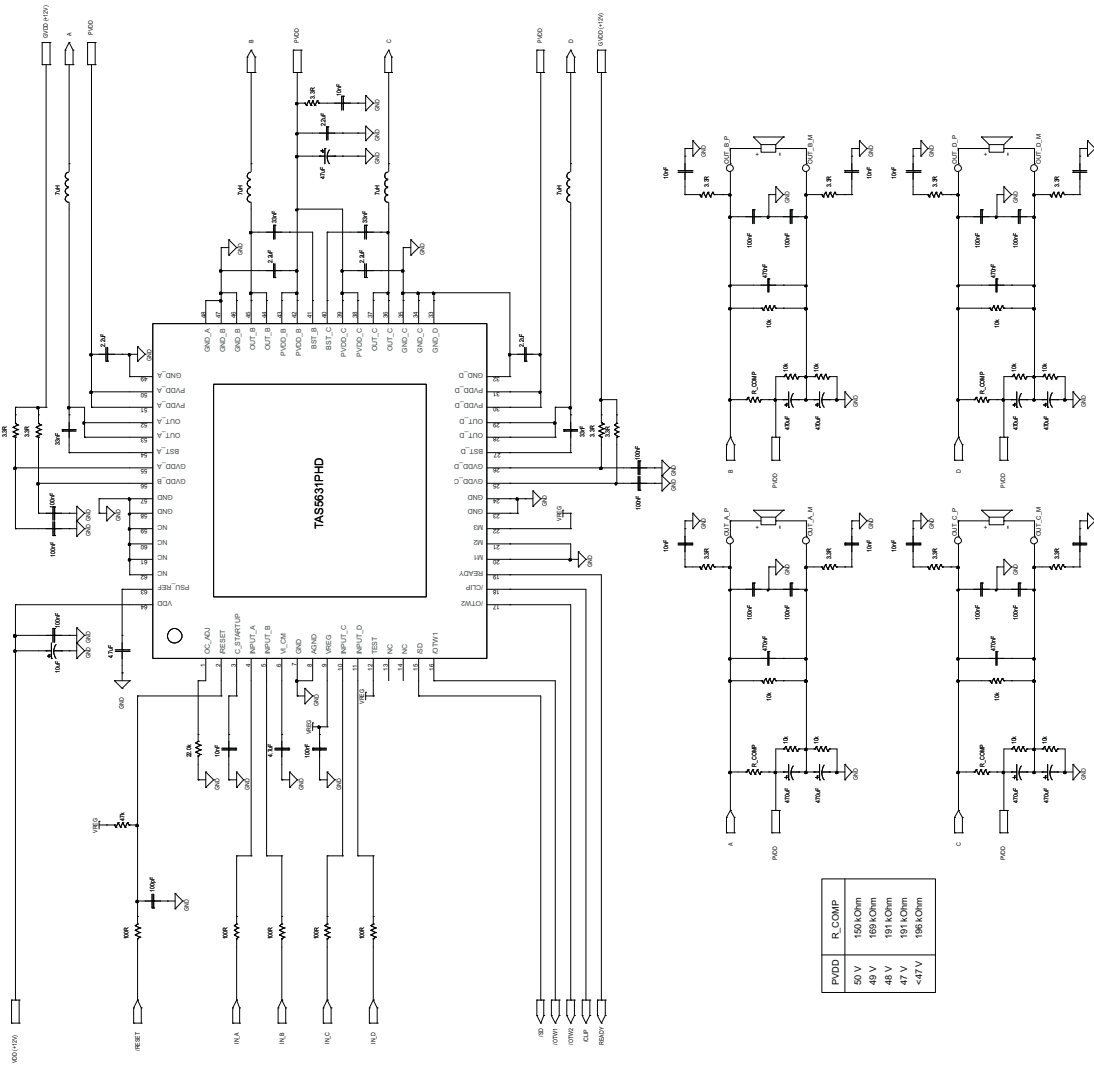

Figure 16. Typical SE Application

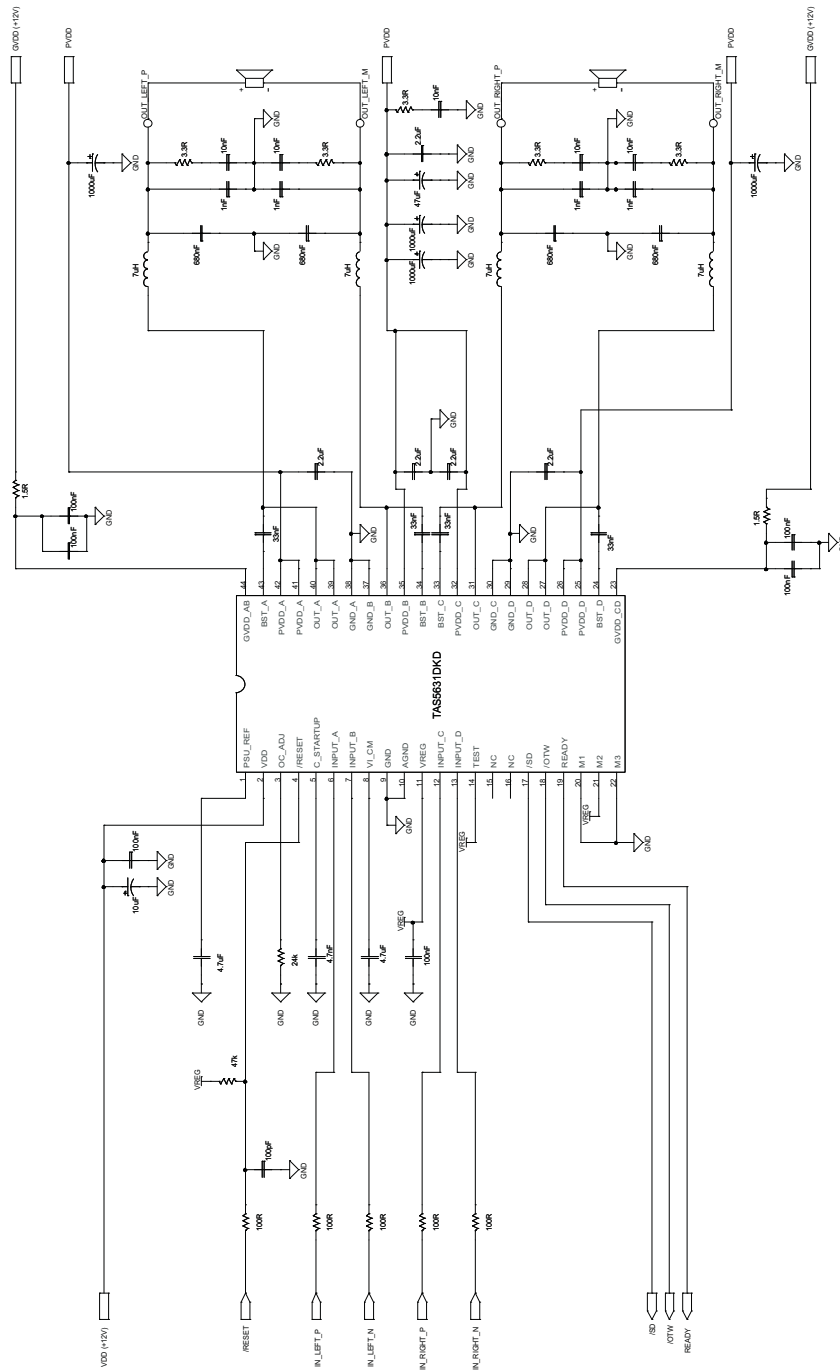

Figure 18. Typical Differential Input BTL Application With BD Modulation Filters, DKD Package

THEORY OF OPERATION

POWER SUPPLIES

To facilitate system design, the TAS5631 needs only a 12-V supply in addition to the (typical) 50-V power-stage supply. An internal voltage regulator provides suitable voltage levels for the digital and low-voltage analog circuitry. Additionally, all circuitry requiring a floating voltage supply, e.g., the high-side gate drive, is accommodated by built-in bootstrap circuitry requiring only an external capacitor for each half-bridge.

To provide outstanding electrical and acoustical characteristics, the PWM signal path, including gate drive and output stage, is designed as identical, independent half-bridges. For this reason, each half-bridge has separate gate-drive supply pins (GVDD_X), bootstrap pins (BST_X), and power-stage supply pins (PVDD_X). Furthermore, an additional pin (VDD) is provided as a supply for all common circuits. Although supplied from the same 12-V source, it is highly recommended to separate GVDD_A, GVDD_B, GVDD_C, GVDD_D, and VDD on the printed-circuit board (PCB) by RC filters (see application diagram for details). These RC filters provide the recommended high-frequency isolation. Special attention should be paid to placing all decoupling capacitors as close to their associated pins as possible. In general, inductance between the power supply pins and decoupling capacitors must be avoided. (See reference board documentation for additional information.)

For a properly functioning bootstrap circuit, a small ceramic capacitor must be connected from each bootstrap pin (BST_X) to the power-stage output pin (OUT_X). When the power-stage output is low, the bootstrap capacitor is charged through an internal diode connected between the gate-drive power-supply pin (GVDD_X) and the bootstrap pin. When the power-stage output is high, the bootstrap capacitor potential is shifted above the output potential and thus provides a suitable voltage supply for the high-side gate driver. In an application with PWM switching frequencies in the range from 300 kHz to 4000 kHz, it is recommended to use 33-nF ceramic capacitors, size 0603 or 0805, for the bootstrap supply. These 33-nF capacitors ensure sufficient energy storage, even during minimal PWM duty cycles, to keep the high-side power stage FET (LDMOS) fully turned on during the remaining part of the PWM cycle.

Special attention should be paid to the power-stage power supply; this includes component selection, PCB placement, and routing. As indicated, each half-bridge has independent power-stage supply pins (PVDD_X). For optimal electrical performance, EMI compliance, and system reliability, it is important that each PVDD_X pin is decoupled with a 2.2- μ F ceramic capacitor placed as close as possible to each supply pin. It is recommended to follow the PCB layout of the TAS5631 reference design. For additional information on recommended power supply and required components, see the application diagrams in this data sheet.

The 12-V supply should be from a low-noise, low-output-impedance voltage regulator. Likewise, the 50-V power-stage supply is assumed to have low output impedance and low noise. The power-supply sequence is not critical as facilitated by the internal power-on-reset circuit. Moreover, the TAS5631 is fully protected against erroneous power-stage turnon due to parasitic gate charging. Thus, voltage-supply ramp rates (dV/dt) are non-critical within the specified range (see the [Recommended Operating Conditions](#) table of this data sheet).

SYSTEM POWER-UP/POWER-DOWN SEQUENCE

Powering Up

The TAS5631 does not require a power-up sequence. The outputs of the H-bridges remain in a high-impedance state until the gate-drive supply voltage (GVDD_X) and VDD voltage are above the undervoltage protection (UVP) voltage threshold (see the [Electrical Characteristics](#) table of this data sheet). Although not specifically required, it is recommended to hold $\overline{\text{RESET}}$ in a low state while powering up the device. This allows an internal circuit to charge the external bootstrap capacitors by enabling a weak pulldown of the half-bridge output.

Powering Down

The TAS5631 does not require a power-down sequence. The device remains fully operational as long as the gate-drive supply (GVDD_X) voltage and VDD voltage are above the undervoltage protection (UVP) voltage threshold (see the [Electrical Characteristics](#) table of this data sheet). Although not specifically required, it is a good practice to hold $\overline{\text{RESET}}$ low during power down, thus preventing audible artifacts including pops or clicks.

ERROR REPORTING

The \overline{SD} , \overline{OTW} , $\overline{OTW1}$, and $\overline{OTW2}$ pins are active-low, open-drain outputs. Their function is for protection-mode signaling to a PWM controller or other system-control device.

Any fault resulting in device shutdown is signaled by the \overline{SD} pin going low. Likewise, \overline{OTW} and $\overline{OTW2}$ go low when the device junction temperature exceeds 125°C and $\overline{OTW1}$ goes low when the junction temperature exceeds 100°C (see the following table).

\overline{SD}	$\overline{OTW1}$	$\overline{OTW2}$, \overline{OTW}	DESCRIPTION
0	0	0	Overtemperature (OTE) or overload (OLP) or undervoltage (UVP)
0	0	1	Overload (OLP) or undervoltage (UVP). Junction temperature higher than 100°C (overtemperature warning)
0	1	1	Overload (OLP) or undervoltage (UVP)
1	0	0	Junction temperature higher than 125°C (overtemperature warning)
1	0	1	Junction temperature higher than 100°C (overtemperature warning)
1	1	1	Junction temperature lower than 100°C and no OLP or UVP faults (normal operation)

Note that asserting \overline{RESET} low forces the \overline{SD} signal high, independent of faults being present. TI recommends monitoring the \overline{OTW} signal using the system microcontroller and responding to an overtemperature warning signal by, e.g., turning down the volume to prevent further heating of the device resulting in device shutdown (OTE).

To reduce external component count, an internal pullup resistor to 3.3 V is provided on both \overline{SD} and \overline{OTW} outputs. Level compliance for 5-V logic can be obtained by adding external pullup resistors to 5 V (see the [Electrical Characteristics](#) table of this data sheet for further specifications).

DEVICE PROTECTION SYSTEM

The TAS5631 contains advanced protection circuitry carefully designed to facilitate system integration and ease of use, as well as to safeguard the device from permanent failure due to a wide range of fault conditions such as short circuits, overload, overtemperature, and undervoltage. The TAS5631 responds to a fault by immediately setting the power stage in a high-impedance (Hi-Z) state and asserting the \overline{SD} pin low. In situations other than overload and overtemperature error (OTE), the device automatically recovers when the fault condition has been removed, i.e., the supply voltage has increased.

The device functions on errors, as shown in the following table.

BTL Mode		PBTL Mode		SE Mode	
Local Error In	Turns Off	Local Error In	Turns Off	Local Error In	Turns Off
A	A + B	A	A + B + C + D	A	A + B
B		B		B	
C	C + D	C		C	C + D
D		D		D	

Bootstrap UVP does not shut down according to the table; it shuts down the respective half-bridge.

PIN-TO-PIN SHORT-CIRCUIT PROTECTION (PPSC)

The PPSC detection system protects the device from permanent damage if a power output pin (OUT_X) is shorted to GND_X or PVDD_X. For comparison, the OC protection system detects an overcurrent after the demodulation filter, whereas PPSC detects shorts directly at the pin before the filter. PPSC detection is performed at startup, i.e., when VDD is supplied; consequently, a short to either GND_X or PVDD_X after system startup does not activate the PPSC detection system. When PPSC detection is activated by a short on the output, all half-bridges are kept in a Hi-Z state until the short is removed; the device then continues the start-up sequence and starts switching. The detection is controlled globally by a two-step sequence. The first step ensures that there are no shorts from OUT_X to GND_X; the second step tests that there are no shorts from OUT_X to PVDD_X. The total duration of this process is roughly proportional to the capacitance of the

output LC filter. The typical duration is $<15 \text{ ms}/\mu\text{F}$. While the PPSC detection is in progress, $\overline{\text{SD}}$ is kept low, and the device does not react to changes applied to the $\overline{\text{RESET}}$ pin. If no shorts are present, the PPSC detection passes, and $\overline{\text{SD}}$ is released. A device reset does not start a new PPSC detection. PPSC detection is enabled in BTL and PBTL output configurations; the detection is not performed in SE mode. To make sure not to trip the PPSC detection system, it is recommended not to insert resistive load to GND_X or PVDD_X .

OVERTEMPERATURE PROTECTION

The two different package options have individual overtemperature protection schemes.

PHD Package

The TAS5631 PHD package option has a three-level temperature-protection system that asserts an active-low warning signal ($\overline{\text{OTW1}}$) when the device junction temperature exceeds 100°C (typical), ($\overline{\text{OTW2}}$) when the device junction temperature exceeds 125°C (typical) and, if the device junction temperature exceeds 155°C (typical), the device is put into thermal shutdown, resulting in all half-bridge outputs being set in the high-impedance (Hi-Z) state and $\overline{\text{SD}}$ being asserted low. OTE is latched in this case. To clear the OTE latch, $\overline{\text{RESET}}$ must be asserted. Thereafter, the device resumes normal operation.

DKD Package

The TAS5631 DKD package option has a two-level temperature-protection system that asserts an active-low warning signal ($\overline{\text{OTW}}$) when the device junction temperature exceeds 125°C (typical) and, if the device junction temperature exceeds 155°C (typical), the device is put into thermal shutdown, resulting in all half-bridge outputs being set in the high-impedance (Hi-Z) state and $\overline{\text{SD}}$ being asserted low. OTE is latched in this case. To clear the OTE latch, $\overline{\text{RESET}}$ must be asserted. Thereafter, the device resumes normal operation.

UNDERVOLTAGE PROTECTION (UVP) AND POWER-ON RESET (POR)

The UVP and POR circuits of the TAS5631 fully protect the device in any power-up/down and brownout situation. While powering up, the POR circuit resets the overload circuit (OLP) and ensures that all circuits are fully operational when the GVDD_X and VDD supply voltages reach values stated in the [Electrical Characteristics](#) table. Although GVDD_X and VDD are independently monitored, a supply-voltage drop below the UVP threshold on any VDD or GVDD_X pin results in all half-bridge outputs immediately being set in the high-impedance (Hi-Z) state and $\overline{\text{SD}}$ being asserted low. The device automatically resumes operation when all supply voltages have increased above the UVP threshold.

DEVICE RESET

When $\overline{\text{RESET}}$ is asserted low, all power-stage FETs in the four half-bridges are forced into a high-impedance (Hi-Z) state.

In BTL modes, to accommodate bootstrap charging prior to switching start, asserting the reset input low enables weak pulldown of the half-bridge outputs. In the SE mode, the output is forced into a high-impedance state when asserting the reset input low. Asserting the reset input low removes any fault information to be signaled on the $\overline{\text{SD}}$ output, i.e., $\overline{\text{SD}}$ is forced high. A rising-edge transition on the reset input allows the device to resume operation after an overload fault. To ensure thermal reliability, the rising edge of reset must occur no sooner than 4 ms after the falling edge of $\overline{\text{SD}}$.

SYSTEM DESIGN CONSIDERATIONS

A rising-edge transition on the reset input allows the device to execute the startup sequence and start switching.

Apply only audio when the state of $\overline{\text{READY}}$ is high; that starts and stops the amplifier without having audible artifacts that are heard in the output transducers. If an overcurrent protection event is introduced, the $\overline{\text{READY}}$ signal goes low; hence, filtering is needed if the signal is intended for audio muting in non-microcontroller systems.

The CLIP signal indicates that the output is approaching clipping. The signal can be used to either an audio volume decrease or intelligent power supply controlling a low and a high rail.

The device inverts the audio signal from input to output.

The $\overline{\text{VREG}}$ pin is not recommended to be used as a voltage source for external circuitry.

PRINTED CIRCUIT BOARD RECOMMENDATION

Use an unbroken ground plane to have good low-impedance and -inductance return path to the power supply for power and audio signals. PCB layout, audio performance and EMI are linked closely together. The circuit contains high, fast-switching currents; therefore, care must be taken to prevent damaging voltage spikes. Routing for the audio input should be kept short and together with the accompanying audio source ground. It is important to keep a solid local ground area underneath the device to minimize ground bounce.

Netlist for this printed circuit board is generated from the schematic in [Figure 14](#).

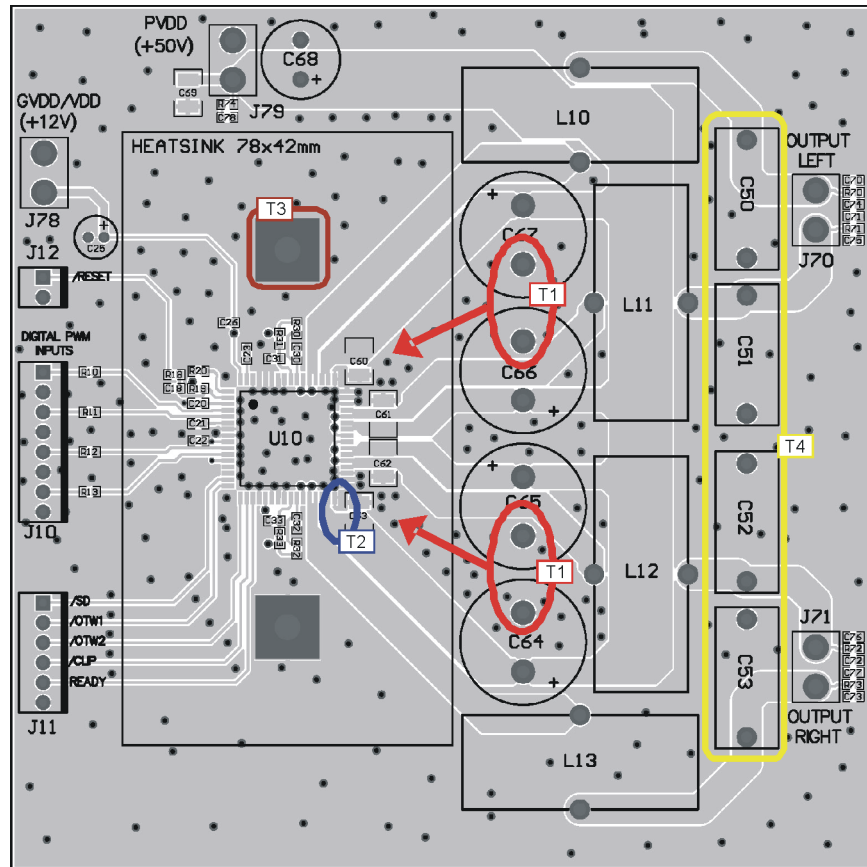

Note T1: PVDD decoupling bulk capacitors C60–C64 should be as close as possible to the PVDD and GND_X pins; the heat sink sets the distance. Wide traces should be routed on the top layer with direct connection to the pins and without going through vias. No vias or traces should be blocking the current path.

Note T2: Close decoupling of PVDD with low-impedance X7R ceramic capacitors is placed under the heat sink and close to the pins.

Note T3: Heat sink must have a good connection to PCB ground.

Note T4: Output filter capacitors must be linear in the applied voltage range, and preferably metal film types.

Figure 19. Printed Circuit Board – Top Layer

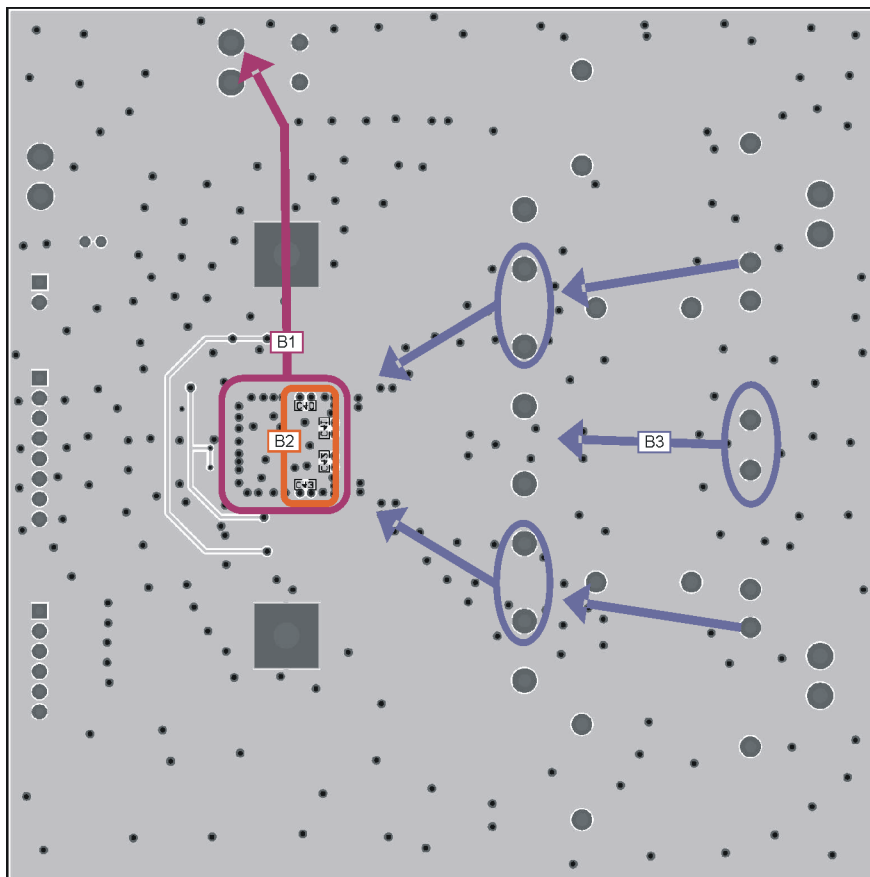

Note B1: It is important to have a direct, low-impedance return path for high current back to the power supply. Keep impedance low from top to bottom side of PCB through a lot of ground vias.

Note B2: Bootstrap low-impedance X7R ceramic capacitors placed on bottom side provide a short low-inductance current loop.

Note B3: Return currents from bulk capacitors and output filter capacitors

Figure 20. Printed Circuit Board – Bottom Layer

REVISION HISTORY

Changes from Original (July 2009) to Revision A	Page
Deleted Product Preview from the PHD package	3
Changes from Revision A (September 2009) to Revision B	Page
Changed OLPC - Overload protection counter TYP value From: 1.3 To: 2.6 ms	10
Changes from Revision B (January 2010) to Revision C	Page
Deleted text form the last paragraph of the DESCRIPTION: Coupled with TI's class-G power-supply reference design for TAS563x, industry-leading levels of efficiency can be achieved.	1
Changed the front page illustration	1
Changed Pin 41 From BST_C To BST_B in the PHD PACKAGE	2

PACKAGING INFORMATION

Orderable Device	Status (1)	Package Type	Package Drawing	Pins	Package Qty	Eco Plan (2)	Lead finish/ Ball material (6)	MSL Peak Temp (3)	Op Temp (°C)	Device Marking (4/5)	Samples
TAS5631PHD	NRND	HTQFP	PHD	64	90	RoHS & Green	NIPDAU	Level-5A-260C-24 HR	0 to 70	TAS5631	

(1) The marketing status values are defined as follows:

ACTIVE: Product device recommended for new designs.

LIFEBUY: TI has announced that the device will be discontinued, and a lifetime-buy period is in effect.

NRND: Not recommended for new designs. Device is in production to support existing customers, but TI does not recommend using this part in a new design.

PREVIEW: Device has been announced but is not in production. Samples may or may not be available.

OBSOLETE: TI has discontinued the production of the device.

(2) **RoHS:** TI defines "RoHS" to mean semiconductor products that are compliant with the current EU RoHS requirements for all 10 RoHS substances, including the requirement that RoHS substance do not exceed 0.1% by weight in homogeneous materials. Where designed to be soldered at high temperatures, "RoHS" products are suitable for use in specified lead-free processes. TI may reference these types of products as "Pb-Free".

RoHS Exempt: TI defines "RoHS Exempt" to mean products that contain lead but are compliant with EU RoHS pursuant to a specific EU RoHS exemption.

Green: TI defines "Green" to mean the content of Chlorine (Cl) and Bromine (Br) based flame retardants meet JS709B low halogen requirements of <=1000ppm threshold. Antimony trioxide based flame retardants must also meet the <=1000ppm threshold requirement.

(3) MSL, Peak Temp. - The Moisture Sensitivity Level rating according to the JEDEC industry standard classifications, and peak solder temperature.

(4) There may be additional marking, which relates to the logo, the lot trace code information, or the environmental category on the device.

(5) Multiple Device Markings will be inside parentheses. Only one Device Marking contained in parentheses and separated by a "-" will appear on a device. If a line is indented then it is a continuation of the previous line and the two combined represent the entire Device Marking for that device.

(6) Lead finish/Ball material - Orderable Devices may have multiple material finish options. Finish options are separated by a vertical ruled line. Lead finish/Ball material values may wrap to two lines if the finish value exceeds the maximum column width.

Important Information and Disclaimer:The information provided on this page represents TI's knowledge and belief as of the date that it is provided. TI bases its knowledge and belief on information provided by third parties, and makes no representation or warranty as to the accuracy of such information. Efforts are underway to better integrate information from third parties. TI has taken and continues to take reasonable steps to provide representative and accurate information but may not have conducted destructive testing or chemical analysis on incoming materials and chemicals. TI and TI suppliers consider certain information to be proprietary, and thus CAS numbers and other limited information may not be available for release.

In no event shall TI's liability arising out of such information exceed the total purchase price of the TI part(s) at issue in this document sold by TI to Customer on an annual basis.

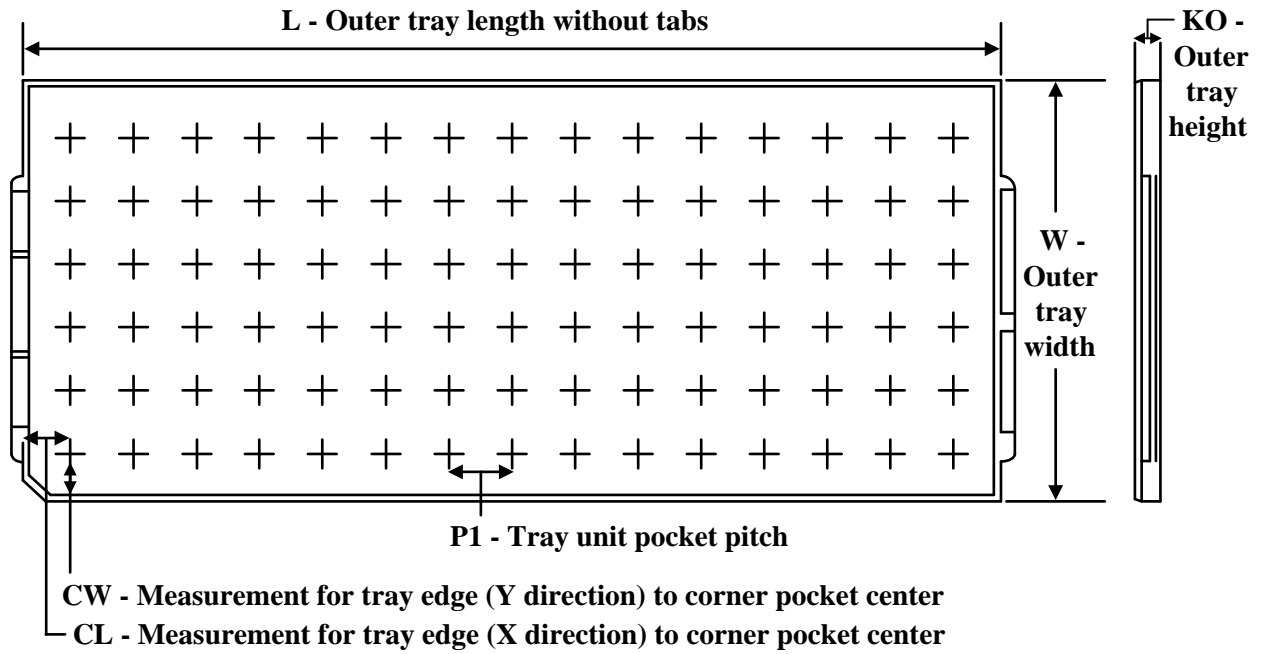
TRAY

Chamfer on Tray corner indicates Pin 1 orientation of packed units.

*All dimensions are nominal

Device	Package Name	Package Type	Pins	SPQ	Unit array matrix	Max temperature (°C)	L (mm)	W (mm)	K0 (µm)	P1 (mm)	CL (mm)	CW (mm)
TAS5631PHD	PHD	HTQFP	64	90	6 X 15	150	315	135.9	7620	20.3	15.4	15.45

GENERIC PACKAGE VIEW

PHD 64

HTQFP - 1.2 mm max height

14 x 14, 0.8 mm pitch

PLASTIC QUAD FLATPACK

This image is a representation of the package family, actual package may vary.
Refer to the product data sheet for package details.

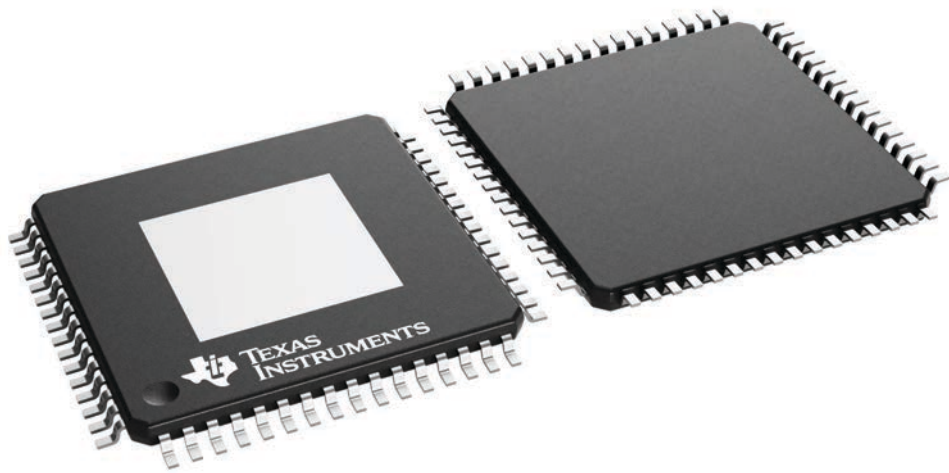

4224851/B

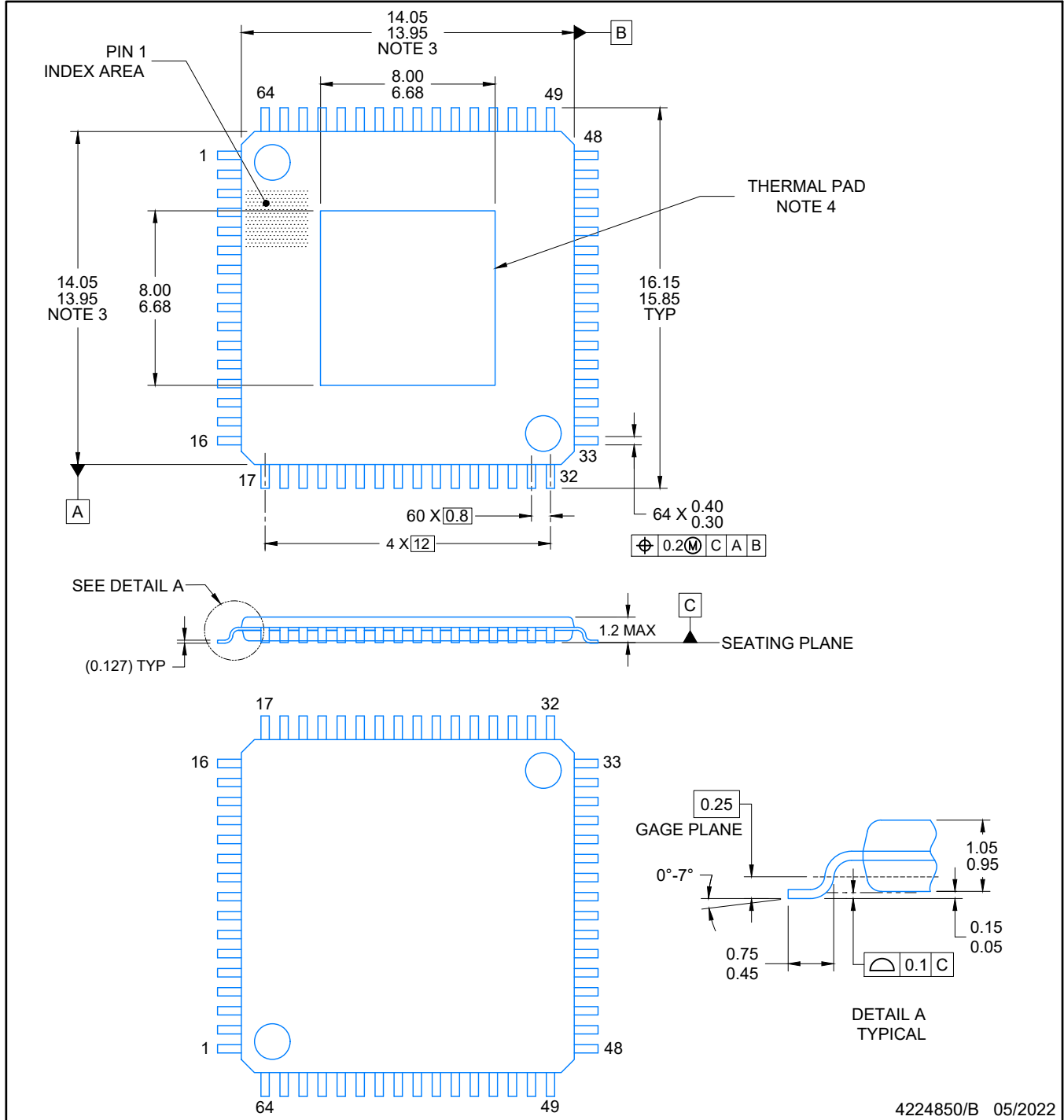

4224850/B 05/2022

NOTES:

1. All linear dimensions are in millimeters. Any dimensions in parenthesis are for reference only. Dimensioning and tolerancing per ASME Y14.5M.
2. This drawing is subject to change without notice.
3. This dimension does not include mold flash, protrusions, or gate burrs. Mold flash, protrusions, or gate burrs shall not exceed 0.15 per side.
4. See technical brief. PowerPad Thermally Enhanced Package, Texas Instruments Literature No. SLMA002 (www.ti.com/lit/slma002) and SLMA004 (www.ti.com/lit/slma004) for information regarding recommended board layout.

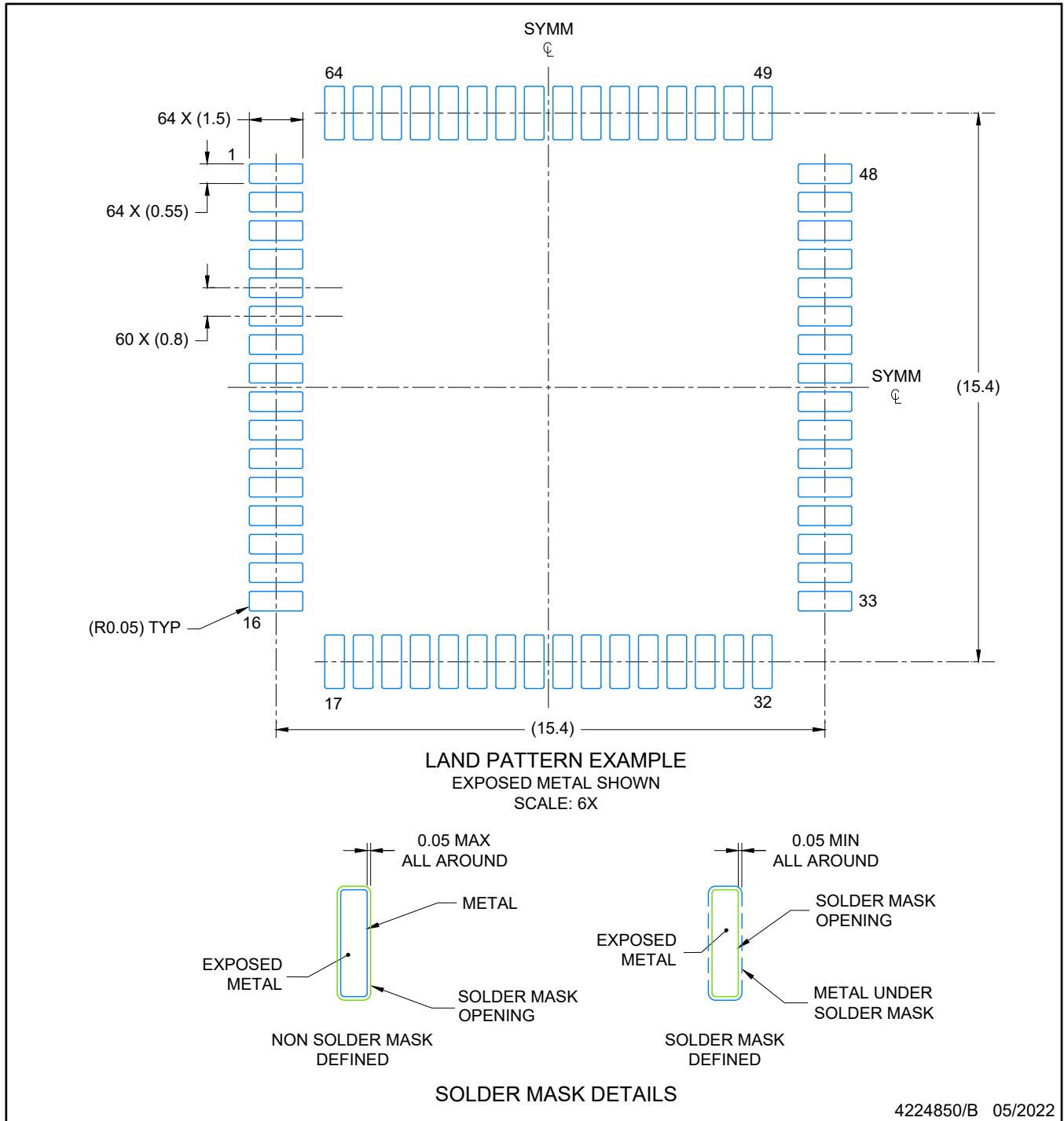

NOTES: (continued)

5. Publication IPC-7351 may have alternate designs.
6. Solder mask tolerances between and around signal pads can vary based on board fabrication site.
7. Vias are optional depending on application, refer to device data sheet. It is recommended that vias under paste be filled, plugged or tented.

EXAMPLE STENCIL DESIGN

HTQFP - 1.2 mm max height

PHD0064B

PLASTIC QUAD FLATPACK

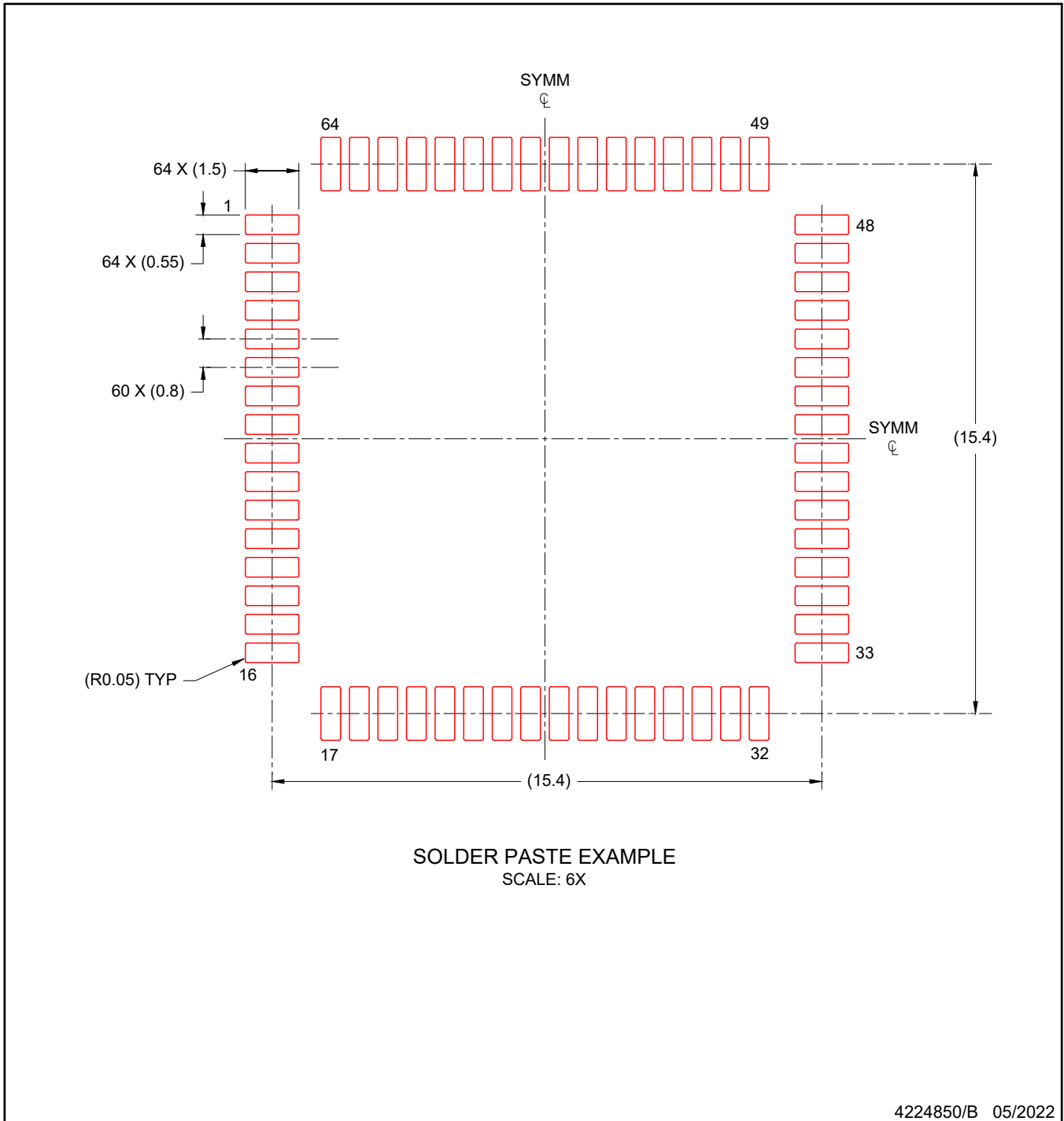

NOTES: (continued)

7. Laser cutting apertures with trapezoidal walls and rounded corners may offer better paste release. IPC-7525 may have alternate design recommendations.
8. Board assembly site may have different recommendations for stencil design.

IMPORTANT NOTICE AND DISCLAIMER

TI PROVIDES TECHNICAL AND RELIABILITY DATA (INCLUDING DATA SHEETS), DESIGN RESOURCES (INCLUDING REFERENCE DESIGNS), APPLICATION OR OTHER DESIGN ADVICE, WEB TOOLS, SAFETY INFORMATION, AND OTHER RESOURCES "AS IS" AND WITH ALL FAULTS, AND DISCLAIMS ALL WARRANTIES, EXPRESS AND IMPLIED, INCLUDING WITHOUT LIMITATION ANY IMPLIED WARRANTIES OF MERCHANTABILITY, FITNESS FOR A PARTICULAR PURPOSE OR NON-INFRINGEMENT OF THIRD PARTY INTELLECTUAL PROPERTY RIGHTS.

These resources are intended for skilled developers designing with TI products. You are solely responsible for (1) selecting the appropriate TI products for your application, (2) designing, validating and testing your application, and (3) ensuring your application meets applicable standards, and any other safety, security, regulatory or other requirements.

These resources are subject to change without notice. TI grants you permission to use these resources only for development of an application that uses the TI products described in the resource. Other reproduction and display of these resources is prohibited. No license is granted to any other TI intellectual property right or to any third party intellectual property right. TI disclaims responsibility for, and you will fully indemnify TI and its representatives against, any claims, damages, costs, losses, and liabilities arising out of your use of these resources.

TI's products are provided subject to [TI's Terms of Sale](#) or other applicable terms available either on [ti.com](https://www.ti.com) or provided in conjunction with such TI products. TI's provision of these resources does not expand or otherwise alter TI's applicable warranties or warranty disclaimers for TI products.

TI objects to and rejects any additional or different terms you may have proposed.

Mailing Address: Texas Instruments, Post Office Box 655303, Dallas, Texas 75265
Copyright © 2024, Texas Instruments Incorporated

Looking for pricing, stock, or lifecycle information?

Click below to explore more details on WIN SOURCE:

 [View TAS5631DKDR on WIN SOURCE](#)

 [Texas Instruments](#) Information

Optimize Your Supply Chain with WIN SOURCE Solutions

-  Global Sourcing Solution
-  Obsolete Management
-  Cost Control Management
-  Shortage Management
-  Alternative Solution
-  Excess Inventory Management