



THE DATASHEET OF TAS5342LDDV6EVM



100 W STEREO DIGITAL AMPLIFIER POWER STAGE

FEATURES

- **Total Power Output (Bridge Tied Load)**
 - 2 × 100 W at 10% THD+N Into 4 Ω
 - 2 × 80 W at 10% THD+N Into 6 Ω
 - 2 × 65 W at 10% THD+N Into 8 Ω
- **Total Power Output (Single Ended)**
 - 4 × 40 W at 10% THD+N Into 3 Ω
 - 4 × 30 W at 10% THD+N Into 4 Ω
- **Total Power Output (Parallel Mode)**
 - 1 × 200 W at 10% THD+N Into 2 Ω
 - 1 × 160 W at 10% THD+N Into 3 Ω
- >110 dB SNR (A-Weighted With TAS5518 Modulator)
- <0.1% THD+N (1 W, 1 kHz)
- Supports PWM Frame Rates of 192 kHz to 432 kHz
- Resistor-Programmable Current Limit
- Integrated Self-Protection Circuitry, Including:
 - Under Voltage Protection
 - Overtemperature Warning and Error
 - Overload Protection
 - Short-Circuit Protection
 - PWM Activity Detector
- Standalone Protection Recovery
- Power-On Reset (POR) to Eliminate System Power-Supply Sequencing
- High-Efficiency Power Stage (>90%) With 110-mΩ Output MOSFETs
- Thermally Enhanced Package 44-Pin HTSSOP (DDV)
- Error Reporting, 3.3-V and 5.0-V Compliant
- EMI Compliant When Used With Recommended System Design

APPLICATIONS

- Mini/Micro Audio System
- DVD Receiver
- Home Theater

DESCRIPTION

The TAS5342L is a high-performance, integrated stereo digital amplifier power stage designed to drive a 4-Ω bridge-tied load (BTL) at up to 100 W per channel with low harmonic distortion, low integrated noise, and low idle current.

The TAS5342L has a complete protection system integrated on-chip, safeguarding the device against a wide range of fault conditions that could damage the system. These protection features are short-circuit protection, over-current protection, under voltage protection, over temperature protection, and a loss of PWM signal (PWM activity detector).

A power-on-reset (POR) circuit is used to eliminate power-supply sequencing that is required for most power-stage designs.

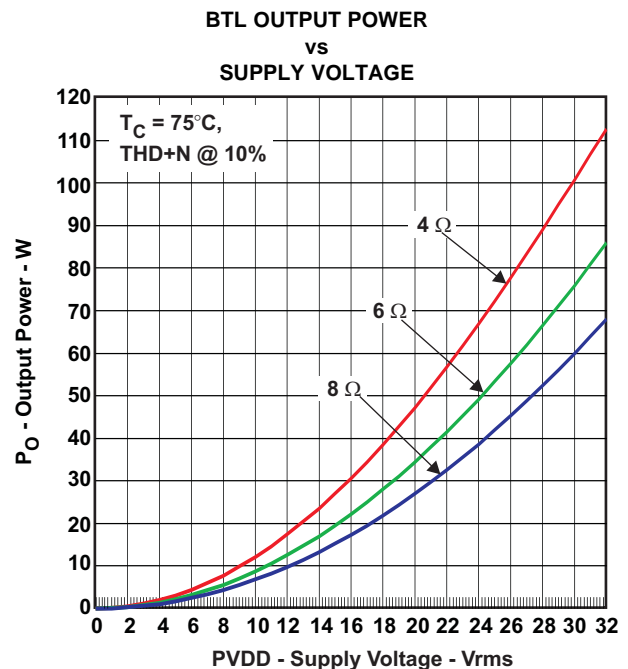

Please be aware that an important notice concerning availability, standard warranty, and use in critical applications of Texas Instruments semiconductor products and disclaimers thereto appears at the end of this data sheet.

PurePath Digital, PowerPad are trademarks of Texas Instruments.
All other trademarks are the property of their respective owners.



These devices have limited built-in ESD protection. The leads should be shorted together or the device placed in conductive foam during storage or handling to prevent electrostatic damage to the MOS gates.

GENERAL INFORMATION

Terminal Assignment

The TAS5342L is available in a thermally enhanced package 44-pin HTSSOP PowerPad™ package (DDV)

This package contains a thermal pad that is located on the top side of the device for convenient thermal coupling to the heatsink.

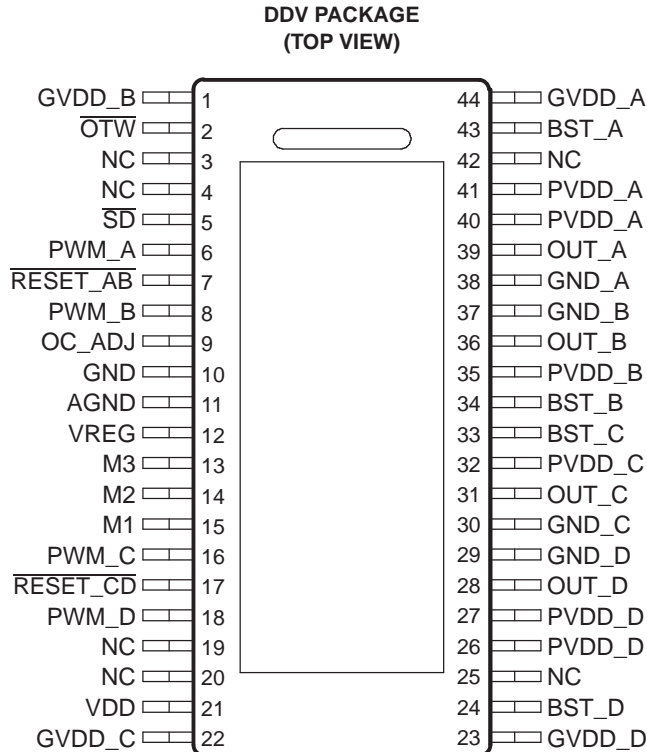

P0016-02

Protection MODE Selection Pins

Protection modes are selected by shorting M1, M2, and M3 to VREG or GND.

MODE PINS			Mode Name	PWM Input ⁽¹⁾	Description
M3	M2	M1			
0	0	0	BTL mode 1	2N	All protection systems enabled
0	0	1	BTL mode 2	2N	Latching shutdown on, PWM activity detector and OLP disabled
0	1	0	BTL mode 3	1N	All protection systems enabled
0	1	1	PBTL mode	1N / 2N ⁽²⁾	All protection systems enabled
1	0	0	SE mode 1	1N	All protection systems enabled ⁽³⁾
1	0	1	SE mode 2	1N	Latching shutdown on, PWM activity detector and OLP disabled ⁽³⁾
1	1	0	Reserved		
1	1	1			

- (1) The 1N and 2N naming convention is used to indicate the number of PWM lines to the power stage per channel in a specific mode.
- (2) PWM_D is used to select between the 1N and 2N interface in PBTL mode (Low = 1N; High = 2N). PWM_D is internally pulled low in PBTL mode. PWM_A is used as the PWM input in 1N mode and PWM_A and PWM_B are used as inputs for the 2N mode.
- (3) PPSC detection system disabled.

Package Heat Dissipation Ratings⁽¹⁾

PARAMETER	TAS5342LDDV
$R_{\theta JC}$ (°C/W)—2 BTL or 4 SE channels	1.8
$R_{\theta JC}$ (°C/W)—1 BTL or 2 SE channel(s)	3.6
$R_{\theta JC}$ (°C/W)—1 SE channel	7.2
Power Pad area ⁽²⁾	36 mm ²

- (1) JC is junction-to-case, CH is case-to-heat sink.
- (2) $R_{\theta CH}$ is an important consideration. Assume a 2-mil thickness of high performance grease with a thermal conductivity at 2.5W/m-K between the pad area and the heat sink. The $R_{\theta CH}$ with this condition is 0.6°C/W for the DDV package.

ABSOLUTE MAXIMUM RATINGSover operating free-air temperature range unless otherwise noted ⁽¹⁾

TAS5342L	
VDD to AGND	–0.3 V to 13.2 V
GVDD_X to AGND	–0.3 V to 13.2 V
PVDD_X to GND_X ⁽²⁾	–0.3 V to 46V
OUT_X to GND_X ⁽²⁾	–0.3 V to 46V
BST_X to GND_X ⁽²⁾	–0.3 V to 59.2 V
BST_X to GVDD_X ⁽²⁾	–0.3 V to 46V
VREG to AGND	–0.3 V to 4.2 V
GND_X to GND	–0.3 V to 0.3 V
GND_X to AGND	–0.3 V to 0.3 V
GND to AGND	–0.3 V to 0.3 V
PWM_X, OC_ADJ, M1, M2, M3 to AGND	–0.3 V to 4.2 V
RESET_X, \overline{SD} , \overline{OTW} to AGND	–0.3 V to 7 V
Maximum continuous sink current (\overline{SD} , \overline{OTW})	9 mA
Maximum operating junction temperature range, T _J	0°C to 125°C
Storage temperature	–40°C to 125°C
Lead temperature, 1,6 mm (1/16 inch) from case for 10 seconds	260°C
Minimum pulse duration, low	30 ns

- (1) Stresses beyond those listed under "absolute maximum ratings" may cause permanent damage to the device. These are stress ratings only, and functional operation of the device at these or any other conditions beyond those indicated under "recommended operating conditions" is not implied. Exposure to absolute-maximum-rated conditions for extended periods may affect device reliability.
- (2) These voltages represent the dc voltage + peak ac waveform measured at the terminal of the device in all conditions.

ORDERING INFORMATION⁽¹⁾

T _A	PACKAGE	DESCRIPTION
0°C to 70°C	TAS5342LDDV	44-pin HTSSOP

- (1) For the most current package and ordering information, see the Package Option Addendum at the end of this document, or see the TI website at www.ti.com.

Terminal Functions

TERMINAL		FUNCTION ⁽¹⁾	DESCRIPTION
NAME	DDV NO.		
AGND	11	P	Analog ground
BST_A	43	P	Bootstrap pin, A-Side
BST_B	34	P	Bootstrap pin, B-Side
BST_C	33	P	Bootstrap pin, C-Side
BST_D	24	P	Bootstrap pin, D-Side
GND	10	P	Ground
GND_A	38	P	Power ground for half-bridge A
GND_B	37	P	Power ground for half-bridge B
GND_C	30	P	Power ground for half-bridge C
GND_D	29	P	Power ground for half-bridge D
GVDD_A	44	P	Gate-drive voltage supply; A-Side
GVDD_B	1	P	Gate-drive voltage supply; B-Side
GVDD_C	22	P	Gate-drive voltage supply; C-Side
GVDD_D	23	P	Gate-drive voltage supply; D-Side
M1	15	I	Mode selection pin (LSB)
M2	14	I	Mode selection pin
M3	13	I	Mode selection pin (MSB)
NC	3, 4, 19, 20, 25, 42	–	No connect. Pins may be grounded.
OC_ADJ	9	O	Analog overcurrent programming pin
$\overline{\text{OTW}}$	2	O	Overtemperature warning signal, open-drain, active-low
OUT_A	39	O	Output, half-bridge A
OUT_B	36	O	Output, half-bridge B
OUT_C	31	O	Output, half-bridge C
OUT_D	28	O	Output, half-bridge D
PVDD_A	40, 41	P	Power supply input for half-bridge A
PVDD_B	35	P	Power supply input for half-bridge B
PVDD_C	32	P	Power supply input for half-bridge C
PVDD_D	26, 27	P	Power supply input for half-bridge D
PWM_A	6	I	PWM Input signal for half-bridge A
PWM_B	8	I	PWM Input signal for half-bridge B
PWM_C	16	I	PWM Input signal for half-bridge C
PWM_D	18	I	PWM Input signal for half-bridge D
$\overline{\text{RESET}}_{\text{AB}}$	7	I	Reset signal for half-bridge A and half-bridge B, active-low
$\overline{\text{RESET}}_{\text{CD}}$	17	I	Reset signal for half-bridge C and half-bridge D, active-low
$\overline{\text{SD}}$	5	O	Shutdown signal, open-drain, active-low
VDD	21	P	Input power supply
VREG	12	P	Internal voltage regulator

(1) I = input, O = output, P = power

TYPICAL SYSTEM BLOCK DIAGRAM

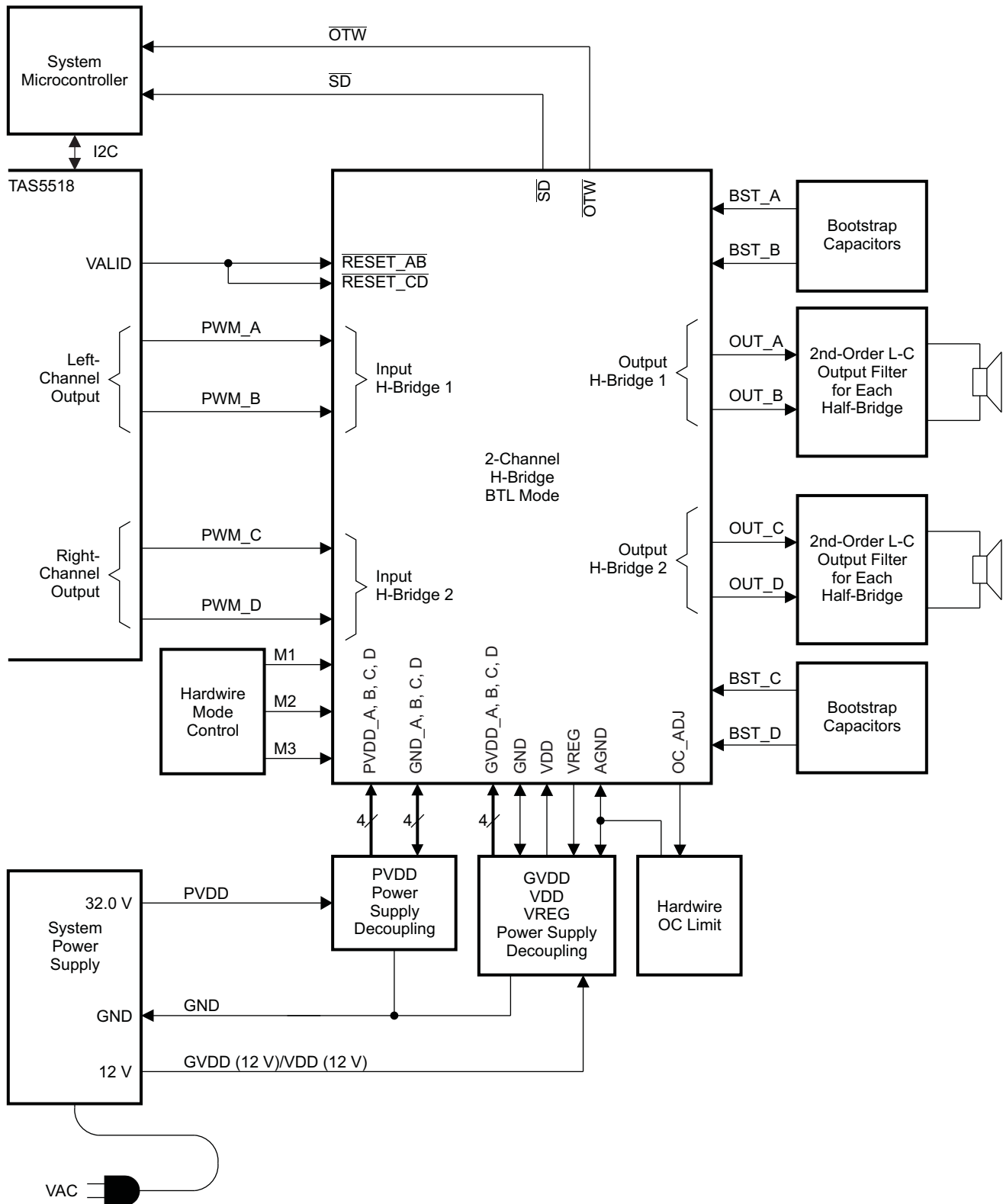

B0047-02

FUNCTIONAL BLOCK DIAGRAM

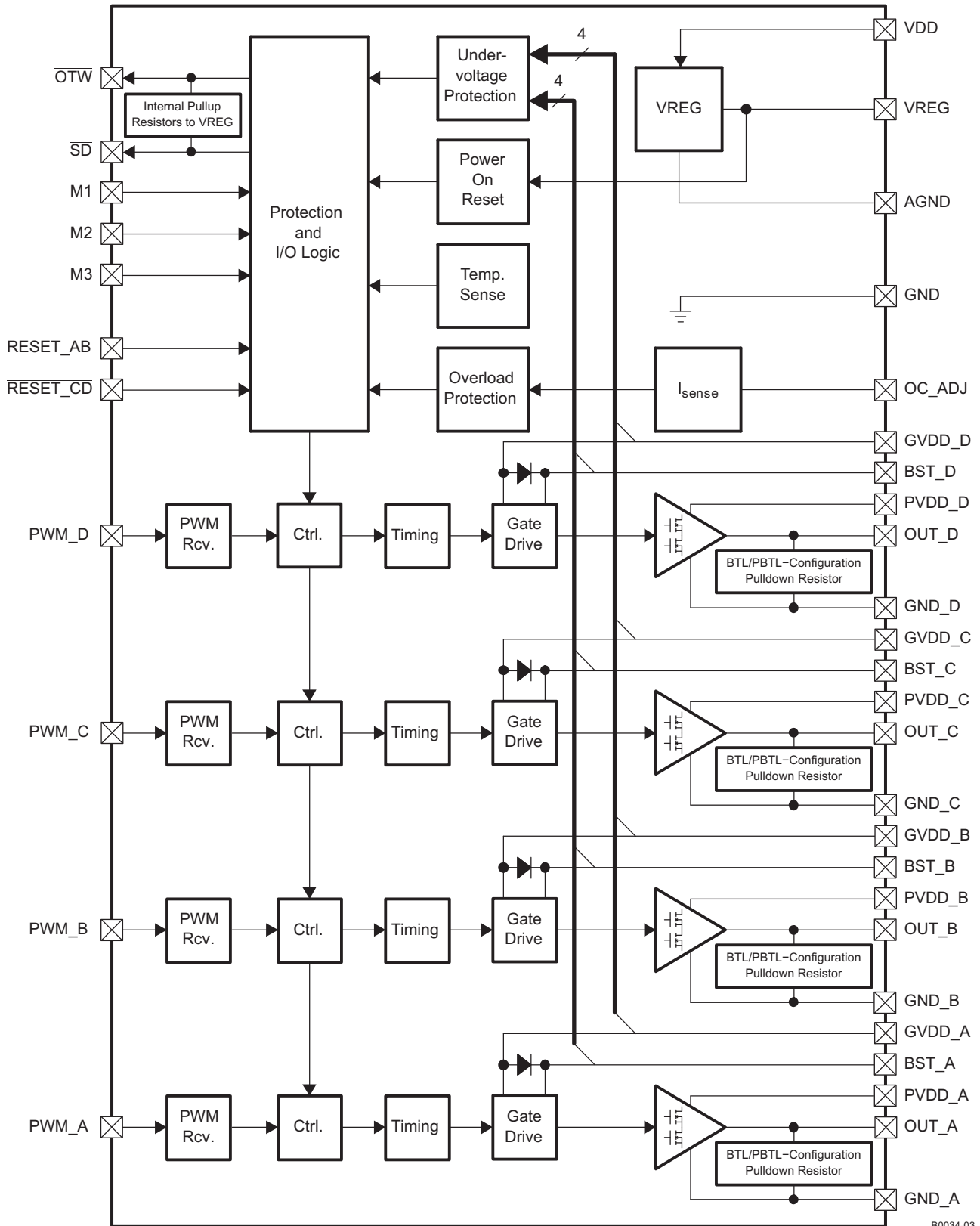

B0034-03

RECOMMENDED OPERATING CONDITIONS

		MIN	TYP	MAX	UNIT		
PVDD_X	Half-bridge supply voltage	0	32.0	34.0	V		
GVDD_X	Supply voltage for logic regulators and gate-drive circuitry	10.8	12	13.2	V		
VDD	Digital regulator supply voltage	10.8	12	13.2	V		
R _L (BTL)	Resistive load impedance (no Cycle-by-Cycle current control), recommended demodulation filter	3	4		Ω		
R _L (SE)		2.25	3				
R _L (PBTL)		1.5	2				
L _{Output} (BTL)	Output-filter inductance	5	10		μH		
L _{Output} (SE)		5	10				
L _{Output} (PBTL)		5	10				
f _S	PWM frame rate	192	384	432	kHz		
t _{LOW}	Minimum low-state pulse duration per PWM Frame, noise shaper enabled	30			nS		
C _{PVDD}	PVDD close decoupling capacitors		0.1		μF		
C _{BST}	Bootstrap capacitor, selected value supports PWM frame rates from 192 kHz to 432 kHz		33		nF		
R _{OC}	Over-current programming resistor	Resistor tolerance = 5%		22	22	47	kΩ
R _{EXT-PULLUP}	External pull-up resistor to +3.3V to +5.0V for \overline{SD} or \overline{OTW}	3.3	4.7			kΩ	
T _J	Junction temperature	0		125		°C	

AUDIO SPECIFICATIONS (BTL)

Audio performance is recorded as a chipset consisting of a TAS5518 pwm processor (modulation index limited to 97.7%) and a TAS5342L power stage. PCB and system configurator are in accordance with recommended guidelines. Audio frequency = 1 kHz, PVDD_x = 32.0 V, GVDD_x = 12 V, R_L = 4 Ω, f_S = 384 kHz, R_{OC} = 22 kΩ, T_C = 75°C, Output Filter: L_{DEM} = 10 μH, C_{DEM} = 470 nF, unless otherwise noted.

PARAMETER		TEST CONDITIONS	TAS5342L			UNIT
			MIN	TYP	MAX	
P _{OMAX}	Maximum Power Output	R _L = 4 Ω, 10% THD+N, clipped input signal		100		W
		R _L = 6 Ω, 10% THD+N, clipped input signal		80		
		R _L = 8 Ω, 10% THD+N, clipped input signal		65		
P _O	Unclipped Power Output	R _L = 4 Ω, 0 dBFS, unclipped input signal		80		
		R _L = 6 Ω, 0 dBFS, unclipped input signal		64		
		R _L = 8 Ω, 0 dBFS, unclipped input signal		50		
THD+N	Total harmonic distortion + noise	0 dBFS; AES17 filter		0.4%		
		1 W; AES17 filter		0.09%		
V _n	Output integrated noise	A-weighted, AES17 filter, Auto mute disabled		55		μV
SNR	Signal-to-noise ratio ⁽¹⁾	A-weighted, AES17 filter, Auto mute disabled		110		dB
DNR	Dynamic range	A-weighted, input level = -60 dBFS, AES17 filter		110		dB
DC Offset	Output offset voltage			+/- 15		mV
P _{idle}	Power dissipation due to idle losses (IPVDD_X)	P _O = 0 W, all halfbridges switching ⁽²⁾		3		W

(1) SNR is calculated relative to 0-dBFS input level.

(2) Actual system idle losses are affected by core losses of output inductors.

AUDIO SPECIFICATIONS (Single-Ended Output)

Audio performance is recorded as a chipset consisting of a TAS5086 pwm processor (modulation index limited to 97.7%) and a TAS5342L power stage. PCB and system configurator are in accordance with recommended guidelines. Audio frequency = 1 kHz, PVDD_x = 32.0 V, GVDD_x = 12 V, R_L = 4 Ω, f_s = 384 kHz, R_{OC} = 22 kΩ, T_C = 75°C, Output Filter: L_{DEM} = 20 μH, C_{DEM} = 1.0 μF, unless otherwise noted.

PARAMETER	TEST CONDITIONS	TAS5342L			UNIT
		MIN	TYP	MAX	
P _{OMAX}	R _L = 3 Ω, 10% THD+N, clipped input signal		40		W
	R _L = 4 Ω, 10% THD+N, clipped input signal		30		
P _O	R _L = 3 Ω, 0 dBFS, unclipped input signal		30		W
	R _L = 4 Ω, 0 dBFS, unclipped input signal		20		
THD+N	0 dBFS; AES17 filter		0.4%		
	1 W; AES17 filter		0.09%		
V _n	A-weighted, AES17 filter, Auto mute disabled		35		μV
SNR	A-weighted, AES17 filter, Auto mute disabled		109		dB
DNR	A-weighted, input level = -60 dBFS AES17 filter		109		dB
P _{idle}	P _O = 0 W, all half bridges switching ⁽²⁾		3		W

(1) SNR is calculated relative to 0-dBFS input level.

(2) Actual system idle losses are affected by core losses of output inductors.

AUDIO SPECIFICATIONS (PBTL)

Audio performance is recorded as a chipset consisting of a TAS5518 pwm processor (modulation index limited to 97.7%) and a TAS5342L power stage. PCB and system configurator are in accordance with recommended guidelines. Audio frequency = 1kHz, PVDD_x = 32.0 V, GVDD_x = 12 V, R_L = 3 Ω, f_s = 384 kHz, R_{OC} = 22 kΩ, T_C = 75°C, Output Filter: L_{DEM} = 10 μH, C_{DEM} = 1.0 uF, unless otherwise noted.

PARAMETER	TEST CONDITIONS	TAS5342L			UNIT
		MIN	TYP	MAX	
P _{OMAX}	R _L = 2 Ω, 10% THD+N, clipped input signal		200		W
	R _L = 3 Ω, 10% THD+N, clipped input signal		160		
P _O	R _L = 2 Ω, 0 dBFS, unclipped input signal		150		W
	R _L = 3 Ω, 0 dBFS, unclipped input signal		120		
THD+N	0 dBFS; AES17 filter		0.4%		
	1 W; AES17 filter		0.09%		
V _n	A-weighted, AES17 filter, Auto mute disabled		45		μV
SNR	A-weighted, AES17 filter, Auto mute disabled		110		dB
DNR	A-weighted, input level = -60 dBFS AES17 filter		110		dB
DC Offset	Output offset voltage		+/- 15		mV

(1) SNR is calculated relative to 0-dBFS input level.

AUDIO SPECIFICATIONS (PBTL) (continued)

Audio performance is recorded as a chipset consisting of a TAS5518 pwm processor (modulation index limited to 97.7%) and a TAS5342L power stage. PCB and system configuraton are in accordance with recommended guidelines. Audio frequency = 1kHz, PVDD_x = 32.0 V, GVDD_x = 12 V, R_L = 3 Ω, f_s = 384 kHz, R_{OC} = 22 kΩ, T_C = 75°C, Output Filter: L_{DEM} = 10 μH, C_{DEM} = 1.0 uF, unless otherwise noted.

PARAMETER	TEST CONDITIONS	TAS5342L			UNIT
		MIN	TYP	MAX	
P _{idle}	Power dissipation due to idle losses (IPVDD _X) P _O = 0 W, all half bridges switching ⁽²⁾		3		W

(2) Actual system idle losses are affected by core losses of output inductors.

ELECTRICAL CHARACTERISTICS

PVDD_x = 32.0 V, GVDD_x = 12 V, VDD = 12 V, T_C (Case temperature) = 25°C, f_s = 384 kHz, unless otherwise specified.

PARAMETER	TEST CONDITIONS	TAS5342L			UNIT		
		MIN	TYP	MAX			
Internal Voltage Regulator and Current Consumption							
VREG	Voltage regulator, only used as a reference node	VDD = 12 V	3	3.3	3.6	V	
IVDD	VDD supply current	Operating, 50% duty cycle		7.1	17	mA	
		Idle, reset mode		5.6	11		
IGVDD _X	Gate supply current per half-bridge	50% duty cycle		5.9	12	mA	
		Reset mode		1	1.8		
IPVDD _X	Half-bridge idle current	50% duty cycle, without output filter or load		10.5	20	mA	
		Reset mode, no switching		594	713		μA
Output Stage MOSFETs							
R _{DSon,LS}	Drain-to-source resistance, Low Side	T _J = 25°C, excludes metallization resistance,		110	125	mΩ	
R _{DSon,HS}	Drain-to-source resistance, High Side	T _J = 25°C, excludes metallization resistance,		110	125	mΩ	
I/O Protection							
V _{uvp,G}	Undervoltage protection limit, GVDD _X			9.5		V	
V _{uvp,hyst} ⁽¹⁾	Undervoltage protection limit, GVDD _X			250		mV	
BST _{uvpF}	Puts device into RESET when BST voltage falls below limit			6.11		V	
BST _{uvpR}	Brings device out of RESET when BST voltage rises above limit			7.25		V	
OTW ⁽¹⁾	Overtemperature warning			115	125	135	°C
OTW _{HYST} ⁽¹⁾	Temperature drop needed below OTW temp. for OTW to be inactive after the OTW event			25			°C
OTE ⁽¹⁾	Overtemperature error threshold			145	155	165	°C
OTE-OTW _{differential} ⁽¹⁾	OTE - OTW differential, temperature delta between OTW and OTE			30			°C
OLPC	Overload protection counter	f _s = 384 kHz		1.25			ms
I _{OC}	Overcurrent limit protection	Resistor—programmable, high-end, R _{OC} = 22 kΩ with 1 ms pulse, T _C = 75°C		7.9	8.4		A
I _{OCT}	Overcurrent response time			150			ns
t _{ACTIVITY DETECTOR}	Time for PWM activity detector to activate when no PWM is present	Lack of transision of any PWM input		13.2			μS

(1) Specified by design

ELECTRICAL CHARACTERISTICS (continued)

PVDD_x = 32.0 V, GVDD_X = 12 V, VDD = 12 V, T_C (Case temperature) = 25°C, f_s = 384 kHz, unless otherwise specified.

PARAMETER		TEST CONDITIONS	TAS5342L			UNIT	
			MIN	TYP	MAX		
I _{PD}	Output pulldown current of each half-bridge	Connected when $\overline{\text{RESET}}$ is active to provide bootstrap capacitor charge. Not used in SE mode.		3		mA	
Static Digital Specifications							
V _{IH}	High-level input voltage	PWM_A, PWM_B, PWM_C, PWM_D, M1, M2, M3, RESET_AB, RESET_CD	2			V	
V _{IL}	Low-level input voltage		0.8			V	
I _{Leakage}	Input leakage current		100			µA	
OTW/SHUTDOWN (SD)							
R _{INT_PU}	Internal pullup resistance, $\overline{\text{OTW}}$ to VREG, $\overline{\text{SD}}$ to VREG		20	26	32	kΩ	
V _{OH}	High-level output voltage	Internal pullup resistor	3	3.3	3.6	V	
		External pullup of 4.7 kΩ to 5 V	4.5				
V _{OL}	Low-level output voltage	I _O = 4 mA	0.2			0.4	V
FANOUT	Device fanout $\overline{\text{OTW}}$, $\overline{\text{SD}}$	No external pullup	30			Devices	

TYPICAL CHARACTERISTICS, BTL CONFIGURATION

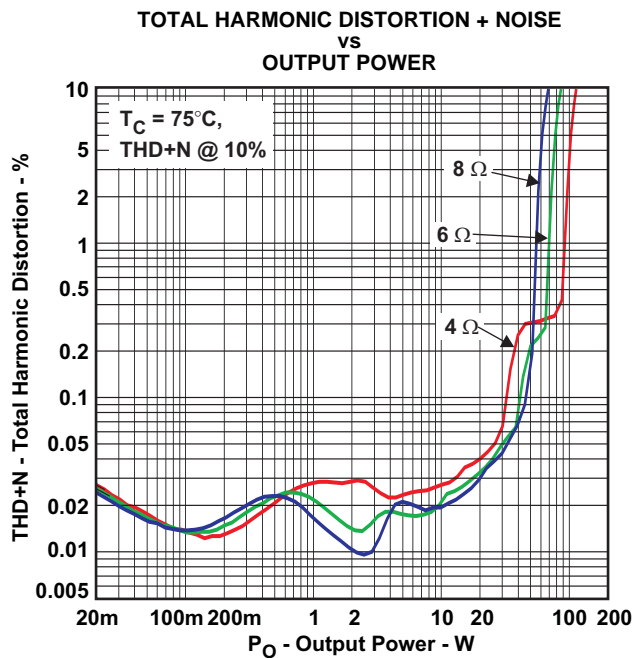

Figure 1.

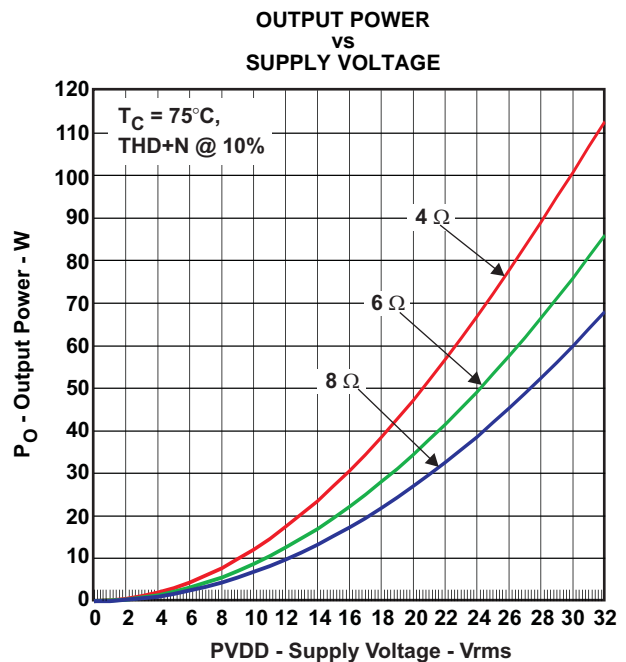

Figure 2.

TYPICAL CHARACTERISTICS, BTL CONFIGURATION (continued)

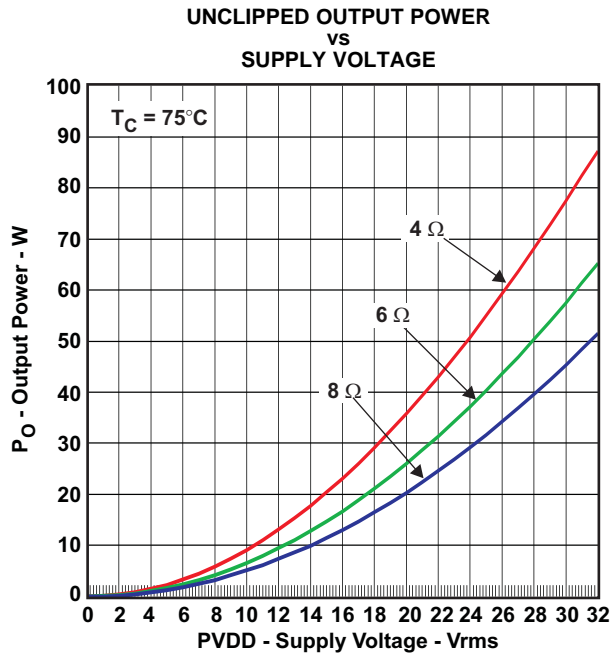

Figure 3.

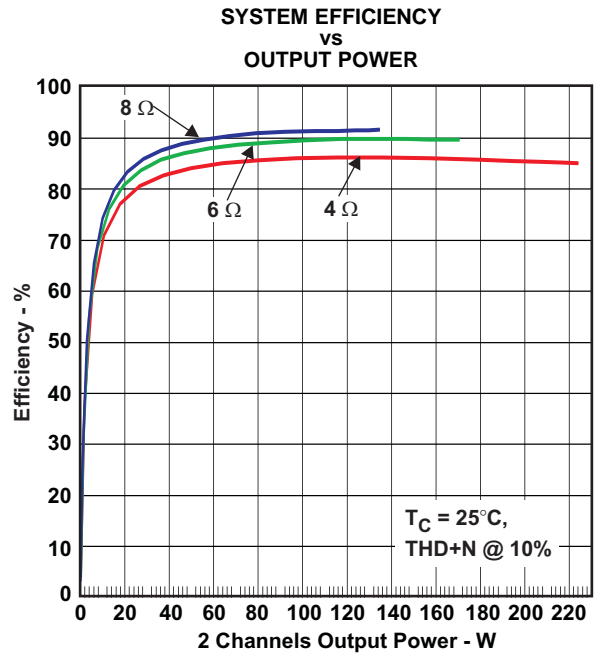

Figure 4.

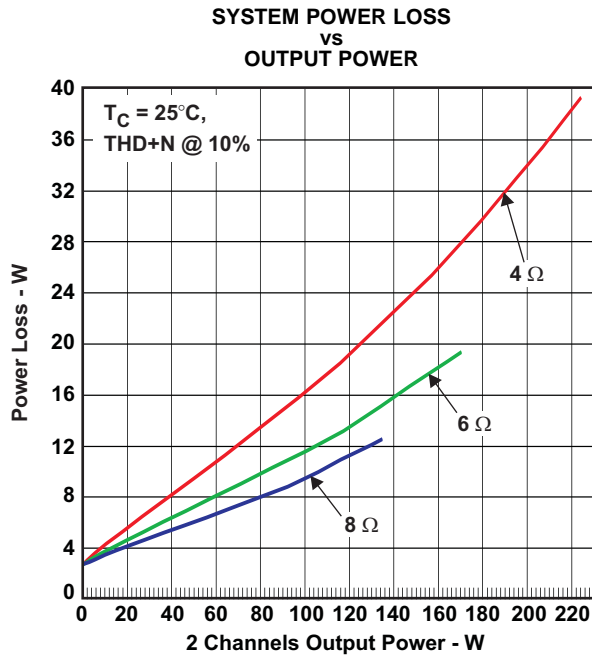

Figure 5.

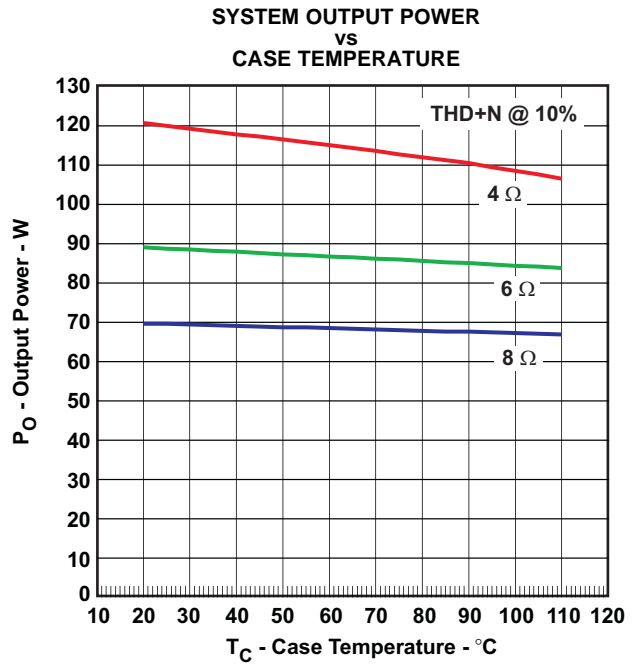
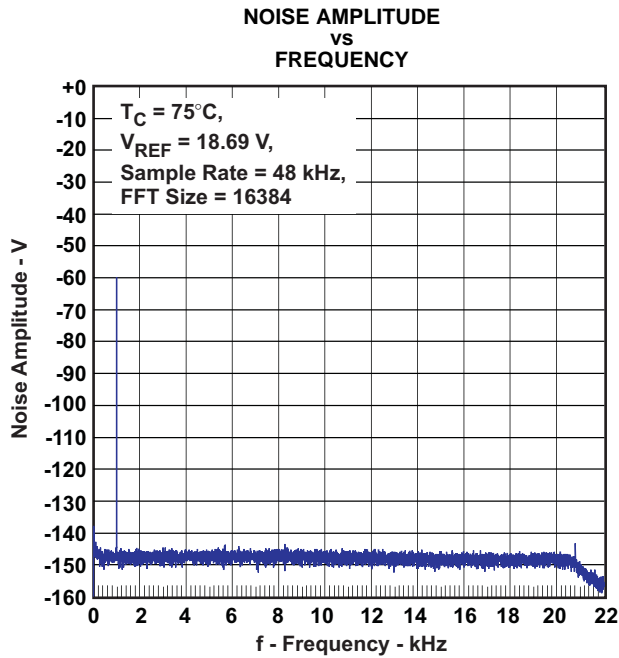
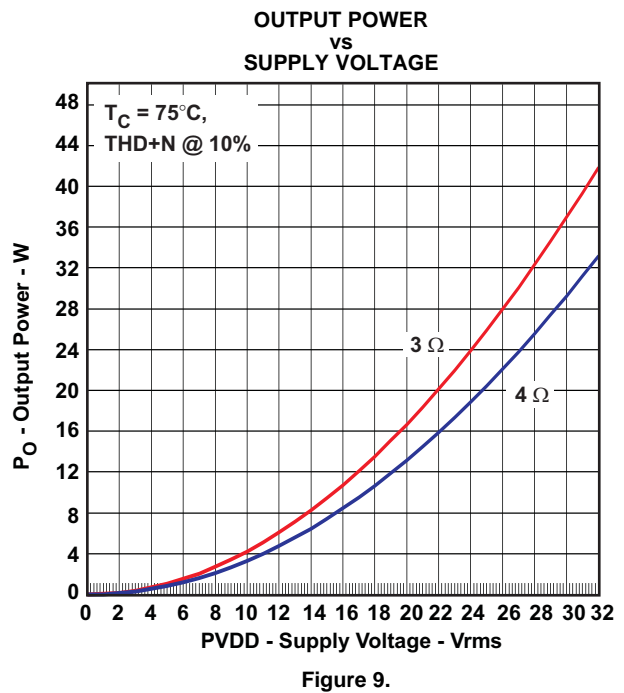
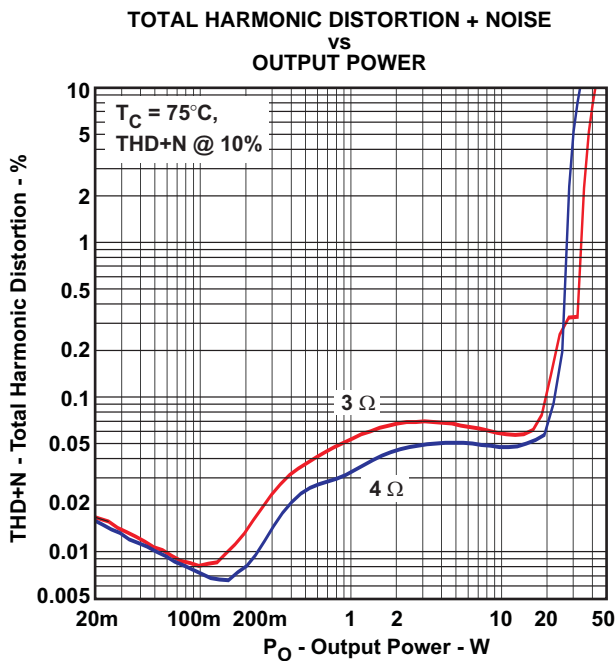

Figure 6.

TYPICAL CHARACTERISTICS, BTL CONFIGURATION (continued)



TYPICAL CHARACTERISTICS, SE CONFIGURATION



TYPICAL CHARACTERISTICS, SE CONFIGURATION (continued)

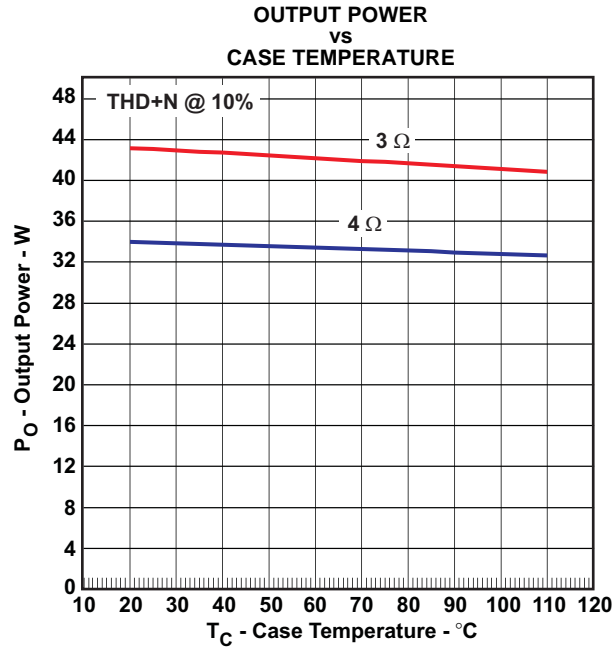

Figure 10.

TYPICAL CHARACTERISTICS, PBTL CONFIGURATION

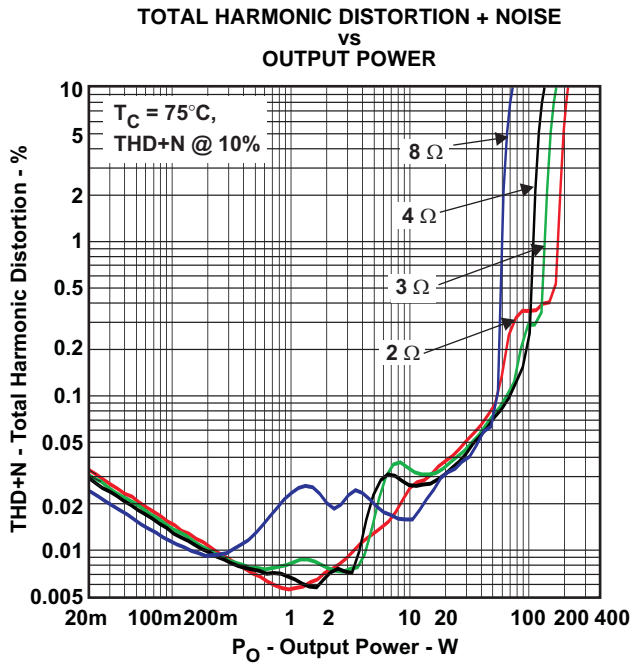

Figure 11.

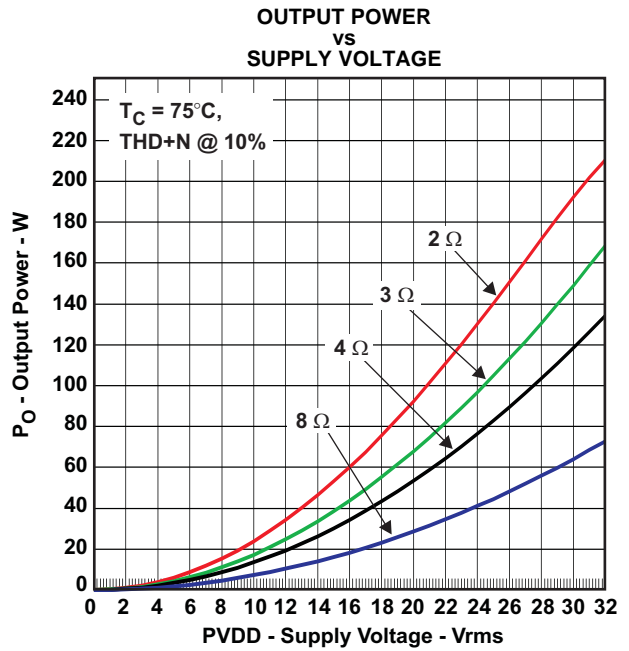

Figure 12.

TYPICAL CHARACTERISTICS, PBTL CONFIGURATION (continued)

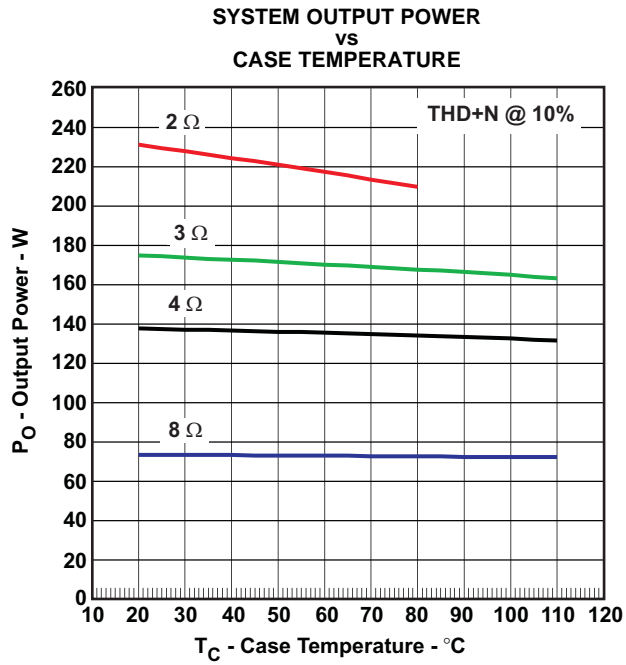

Figure 13.

APPLICATION INFORMATION

PCB Material Recommendation

FR-4 Glass Epoxy material with 2 oz. (70 μm) is recommended for use with the TAS5342L. The use of this material can provide for higher power output, improved thermal performance, and better EMI margin (due to lower PCB trace inductance).

PVDD Capacitor Recommendation

The large capacitors used in conjunction with each full-bridge, are referred to as the PVDD Capacitors. These capacitors should be selected for proper voltage margin and adequate capacitance to support the power requirements. In practice, with a well designed system power supply, 1000 μF , 50-V will support more applications. The PVDD capacitors should be low ESR type because they are used in a circuit associated with high-speed switching.

Decoupling Capacitor Recommendations

In order to design an amplifier that has robust performance, passes regulatory requirements, and exhibits good audio performance, good quality decoupling capacitors should be used. In practice, X7R should be used in this application.

The voltage of the decoupling capacitors should be selected in accordance with good design practices. Temperature, ripple current, and voltage overshoot must be considered. This fact is particularly true in the selection of the 0.1 μF that is placed on the power supply to each half-bridge. It must withstand the voltage overshoot of the PWM switching, the heat generated by the amplifier during high power output, and the ripple current created by high power power output. A minimum voltage rating of **50-V** is required for use with a 32.0 V power supply.

System Design Recommendations

The following schematics and PCB layouts illustrate "best practices" in the use of the TAS5342L.

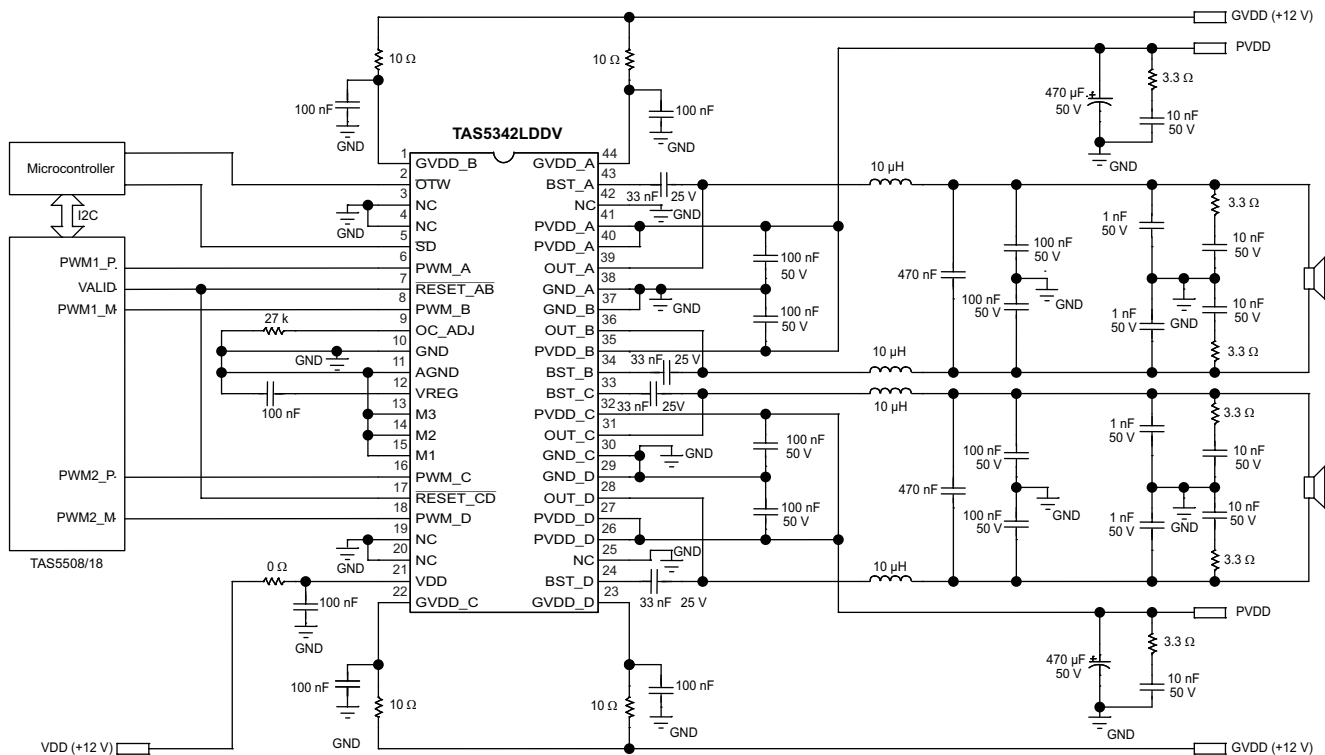

Figure 14. Typical Differential (2N) BTL Application With AD Modulation Filters

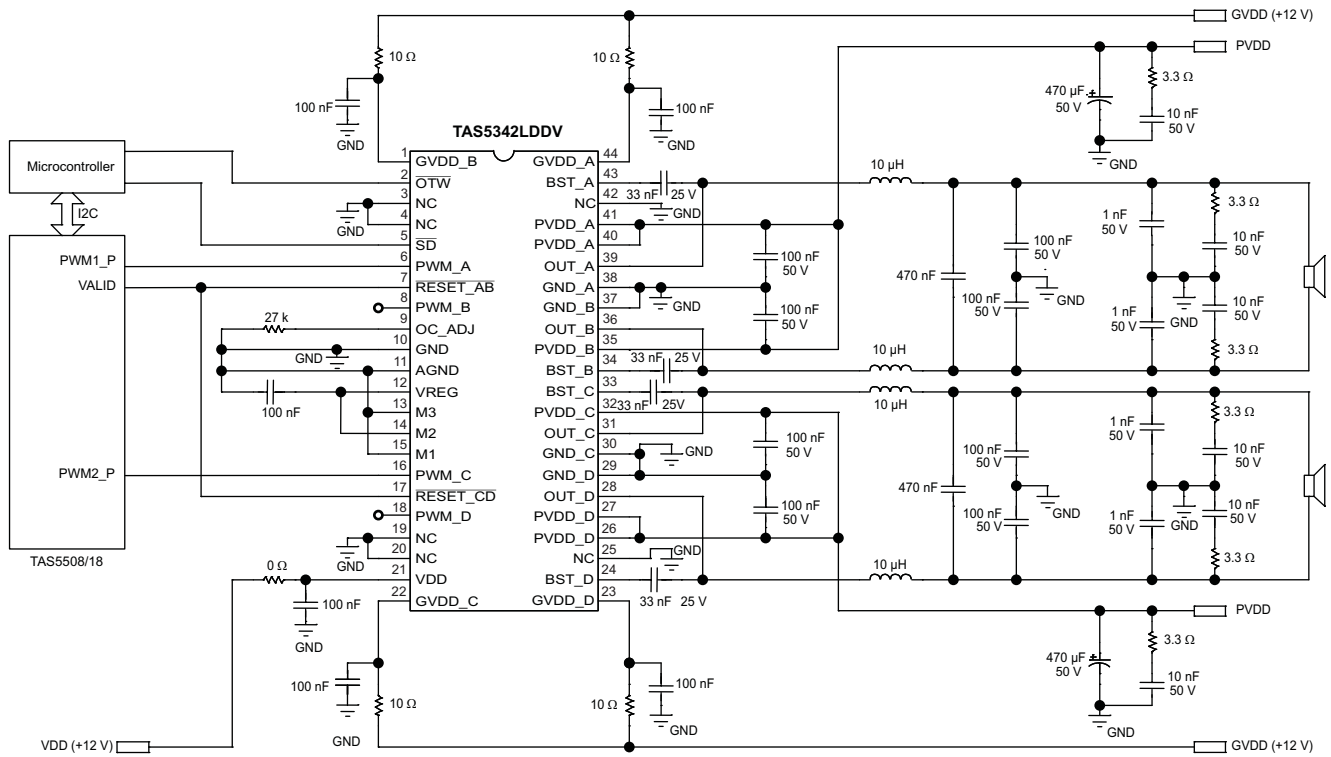

Figure 15. Typical Non-Differential (1N) BTL Application With AD Modulation Filters

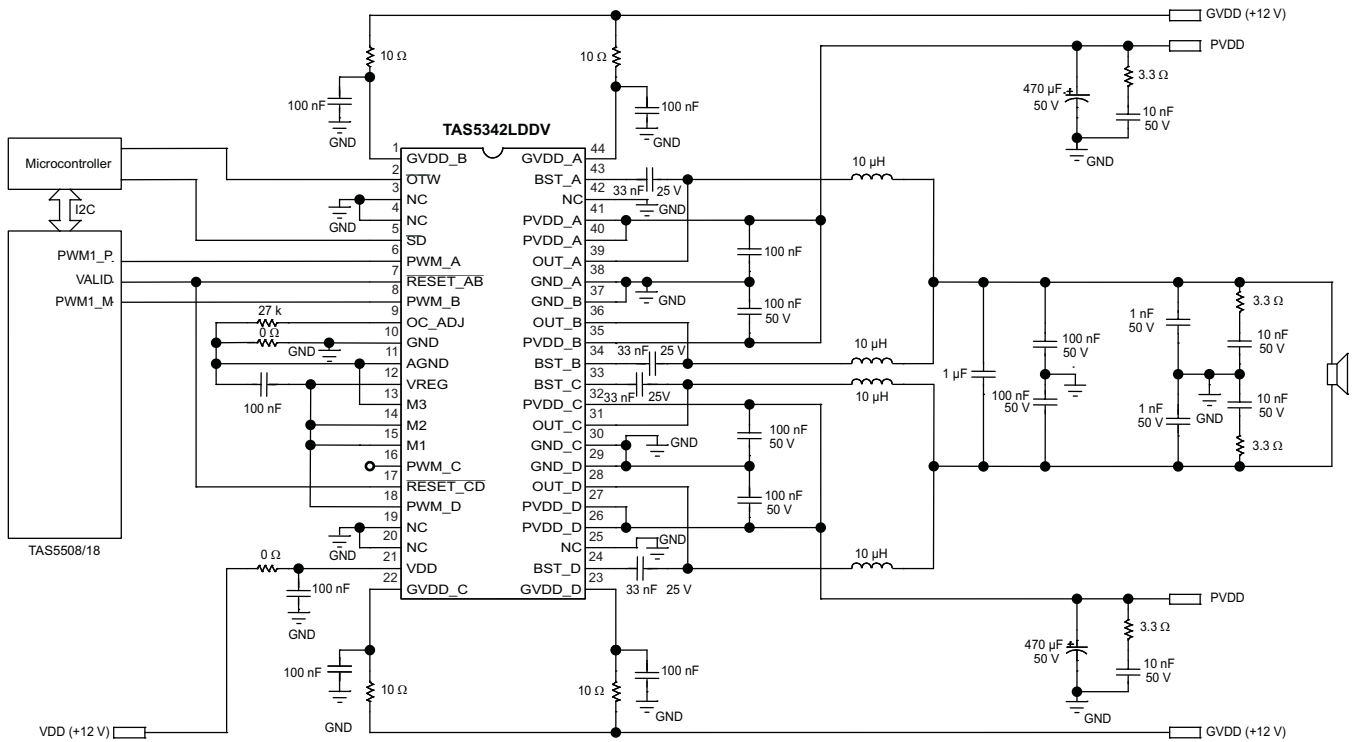

Figure 17. Typical Differential (2N) PBTB Application With AD Modulation Filters

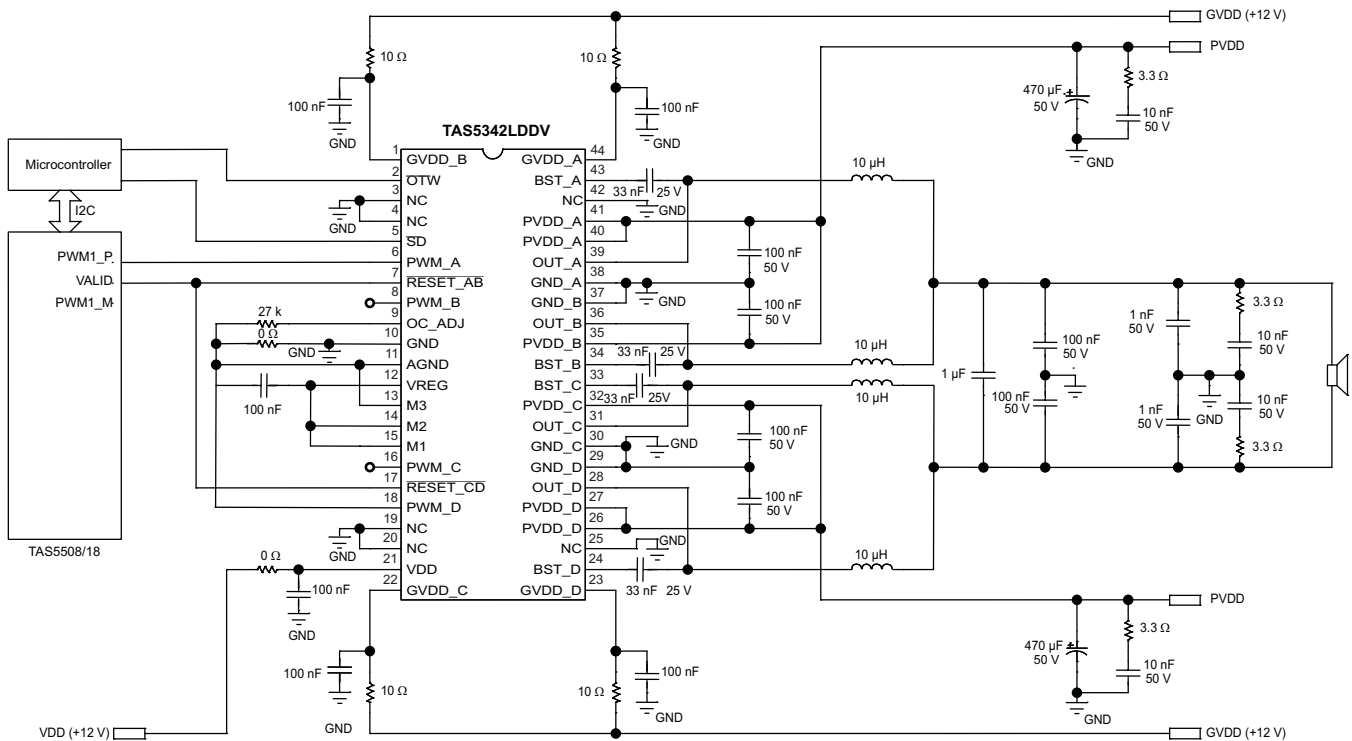

Figure 18. Typical Non-Differential (1N) PBTB Application

THEORY OF OPERATION

POWER SUPPLIES

To facilitate system design, the TAS5342L needs only a 12-V supply in addition to the (typical) 32.0-V power-stage supply. An internal voltage regulator provides suitable voltage levels for the digital and low-voltage analog circuitry. Additionally, all circuitry requiring a floating voltage supply, e.g., the high-side gate drive, is accommodated by built-in bootstrap circuitry requiring only an external capacitor for each half-bridge.

In order to provide outstanding electrical and acoustical characteristics, the PWM signal path including gate drive and output stage is designed as identical, independent half-bridges. For this reason, each half-bridge has separate gate drive supply (GVDD_X), bootstrap pins (BST_X), and power-stage supply pins (PVDD_X). Furthermore, an additional pin (VDD) is provided as supply for all common circuits. Although supplied from the same 12-V source, it is highly recommended to separate GVDD_A, GVDD_B, GVDD_C, GVDD_D, and VDD on the printed-circuit board (PCB) by RC filters (see application diagram for details). These RC filters provide the recommended high-frequency isolation. Special attention should be paid to placing all decoupling capacitors as close to their associated pins as possible. In general, inductance between the power supply pins and decoupling capacitors must be avoided. (See reference board documentation for additional information.)

For a properly functioning bootstrap circuit, a small ceramic capacitor must be connected from each bootstrap pin (BST_X) to the power-stage output pin (OUT_X). When the power-stage output is low, the bootstrap capacitor is charged through an internal diode connected between the gate-drive power-supply pin (GVDD_X) and the bootstrap pin. When the power-stage output is high, the bootstrap capacitor potential is shifted above the output potential and thus provides a suitable voltage supply for the high-side gate driver. In an application with PWM switching frequencies in the range from 352 kHz to 384 kHz, it is recommended to use 33-nF ceramic capacitors, size 0603 or 0805, for the bootstrap supply. These 33-nF capacitors ensure sufficient energy storage, even during minimal PWM duty cycles, to keep the high-side power stage FET (LDMOS) fully turned on during the remaining part of the PWM cycle. In an application running at a reduced switching frequency, generally 192 kHz, the bootstrap capacitor might need to be increased in value.

Special attention should be paid to the power-stage power supply; this includes component selection, PCB placement, and routing. As indicated, each half-bridge has independent power-stage supply pins (PVDD_X). For optimal electrical performance, EMI compliance, and system reliability, it is important that each PVDD_X pin is decoupled with a 100-nF ceramic capacitor placed as close as possible to each supply pin. It is recommended to follow the PCB layout of the TAS5342L reference design. For additional information on recommended power supply and required components, see the application diagrams given previously in this data sheet.

The 12-V supply should be from a low-noise, low-output-impedance voltage regulator. Likewise, the 32.0 V power-stage supply is assumed to have low output impedance and low noise. The power-supply sequence is not critical as facilitated by the internal power-on-reset circuit. Moreover, the TAS5342L is fully protected against erroneous power-stage turnon due to parasitic gate charging. Thus, voltage-supply ramp rates (dV/dt) are non-critical within the specified range (see the *Recommended Operating Conditions* section of this data sheet).

SYSTEM POWER-UP/POWER-DOWN SEQUENCE

Powering Up

The TAS5342L does not require a power-up sequence. The outputs of the H-bridges remain in a high-impedance state until the gate-drive supply voltage (GVDD_X) and VDD voltage are above the undervoltage protection (UVP) voltage threshold (see the *Electrical Characteristics* section of this data sheet). Although not specifically required, it is recommended to hold $\overline{\text{RESET_AB}}$ and $\overline{\text{RESET_CD}}$ in a low state while powering up the device. This allows an internal circuit to charge the external bootstrap capacitors by enabling a weak pulldown of the half-bridge output.

When the TAS5342L is being used with TI PWM modulators such as the TAS5518, no special attention to the state of $\overline{\text{RESET_AB}}$ and $\overline{\text{RESET_CD}}$ is required, provided that the chipset is configured as recommended.

Powering Down

The TAS5342L does not require a power-down sequence. The device remains fully operational as long as the gate-drive supply (GVDD_X) voltage and VDD voltage are above the undervoltage protection (UVP) voltage threshold (see the *Electrical*

Characteristics section of this data sheet). Although not specifically required, it is a good practice to hold $\overline{\text{RESET_AB}}$ and $\overline{\text{RESET_CD}}$ low during power down, thus preventing audible artifacts including pops or clicks.

When the TAS5342L is being used with TI PWM modulators such as the TAS5518, no special attention to the state of $\overline{\text{RESET_AB}}$ and $\overline{\text{RESET_CD}}$ is required, provided that the chipset is configured as recommended.

Mid Z Sequence Compatibility

The TAS5342L is compatible with the Mid Z sequence of the TAS5086 Modulator. The Mid Z Sequence is a series of pulses that is generated by the modulator. This sequence causes the power stage to slowly enable its outputs as it begins to switch.

By slowly starting the PWM switching, the impulse response created by the onset of switching is reduced. This impulse response is the acoustic artifact that is heard in the output transducers (loudspeakers) and is commonly termed "click" or "pop".

The low acoustic artifact noise of the TAS5342L will be further decreased when used in conjunction with the TAS5086 modulator with the Mid Z Sequence enabled.

The Mid Z sequence is primarily used for the single-ended output configuration. It facilitates a "softer" PWM output start after the split cap output configuration is charged.

ERROR REPORTING

The $\overline{\text{SD}}$ and $\overline{\text{OTW}}$ pins are both active-low, open-drain outputs. Their function is for protection-mode signaling to a PWM controller or other system-control device.

Any fault resulting in device shutdown is signaled by the $\overline{\text{SD}}$ pin going low. Likewise, $\overline{\text{OTW}}$ goes low when the device junction temperature exceeds 125°C (see the following table).

$\overline{\text{SD}}$	$\overline{\text{OTW}}$	DESCRIPTION
0	0	Overtemperature (OTE) or overload (OLP) or undervoltage (UVP)
0	1	Overload (OLP) or undervoltage (UVP)
1	0	Junction temperature higher than 125°C (overtemperature warning)
1	1	Junction temperature lower than 125°C and no OLP or UVP faults (normal operation)

Note that asserting either $\overline{\text{RESET_AB}}$ or $\overline{\text{RESET_CD}}$ low forces the $\overline{\text{SD}}$ signal high, independent of faults being present. TI recommends monitoring the $\overline{\text{OTW}}$

signal using the system microcontroller and responding to an overtemperature warning signal by, e.g., turning down the volume to prevent further heating of the device resulting in device shutdown (OTE).

To reduce external component count, an internal pullup resistor to 3.3 V is provided on both $\overline{\text{SD}}$ and $\overline{\text{OTW}}$ outputs. Level compliance for 5-V logic can be obtained by adding external pullup resistors to 5 V (see the *Electrical Characteristics* section of this data sheet for further specifications).

DEVICE PROTECTION SYSTEM

The TAS5342L contains advanced protection circuitry carefully designed to facilitate system integration and ease of use, as well as to safeguard the device from permanent failure due to a wide range of fault conditions such as short circuits, overload, overtemperature, and undervoltage. The TAS5342L responds to a fault by immediately setting the power stage in a high-impedance (Hi-Z) state and asserting the $\overline{\text{SD}}$ pin low. In situations other than overload and over-temperature error ($\overline{\text{OTE}}$), the device automatically recovers when the fault condition has been removed, i.e., the supply voltage has increased.

The device will function on errors, as shown in the following table.

BTL MODE		PBTL MODE		SE MODE	
Local Error In	Turns Off	Local Error In	Turns Off	Local Error In	Turns Off
A	A + B	A	A + B + C + D	A	A + B
B		B		B	
C	C	C			
D	C + D	D		D	C + D

Bootstrap UVP does not shutdown according to the table, it shutdowns the respective halfbridge.

Use of TAS5342L in High-Modulation-Index Capable Systems

This device requires at least 30 ns of low time on the output per 384-kHz PWM frame rate in order to keep the bootstrap capacitors charged. As an example, if the modulation index is set to 99.2% in the TAS5508, this setting allows PWM pulse durations down to 10 ns. This signal, which does not meet the 30-ns requirement, is sent to the PWM_X pin and this low-state pulse time does not allow the bootstrap capacitor to stay charged. The TAS5342L device requires limiting the TAS5508 modulation index to 97.7% to keep the bootstrap capacitor charged under all signals and loads.

The TAS5342L contains a bootstrap capacitor under voltage protection circuit (BST_UVP) that monitors the voltage on the bootstrap capacitors. When the

voltage on the bootstrap capacitors is less than required for proper control of the High-Side MOSFETs, the device will initiate bootstrap capacitor recharge sequences until the bootstrap capacitors are properly charged for robust operation. This function may be activated with PWM pulses less than 30 nS.

Therefore, TI strongly recommends using a TI PWM processor, such as TAS5518, TAS5086 or TAS5508, with the modulation index set at 97.7% to interface with TAS5342L.

Overcurrent (OC) Protection With Current Limiting and Overload Detection

The device has independent, fast-reacting current detectors with programmable trip threshold (OC threshold) on all high-side and low-side power-stage FETs. See the following table for OC-adjust resistor values. The detector outputs are closely monitored by two protection systems. The first protection system controls the power stage in order to prevent the output current from further increasing, i.e., it performs a current-limiting function rather than prematurely shutting down during combinations of high-level music transients and extreme speaker load impedance drops. If the high-current situation persists, i.e., the power stage is being overloaded, a second protection system triggers a latching shutdown, resulting in the power stage being set in the high-impedance (Hi-Z) state. Current limiting and overload protection are independent for half-bridges A and B and, respectively, C and D. That is, if the bridge-tied load between half-bridges A and B causes an overload fault, only half-bridges A and B are shut down.

- For the lowest-cost bill of materials in terms of component selection, the OC threshold measure should be limited, considering the power output requirement and minimum load impedance. Higher-impedance loads require a lower OC threshold.
- The demodulation-filter inductor must retain at least 5 μ H of inductance at twice the OC threshold setting.

Unfortunately, most inductors have decreasing inductance with increasing temperature and increasing current (saturation). To some degree, an increase in temperature naturally occurs when operating at high output currents, due to core losses and the dc resistance of the inductor's copper winding. A thorough analysis of inductor saturation and thermal properties is strongly recommended.

Setting the OC threshold too low might cause issues such as lack of enough output power and/or unexpected shutdowns due to too-sensitive overload detection.

In general, it is recommended to follow closely the external component selection and PCB layout as given in the *Application* section.

For added flexibility, the OC threshold is programmable within a limited range using a single external resistor connected between the OC_ADJ pin and AGND. (See the *Electrical Characteristics* section of this data sheet for information on the correlation between programming-resistor value and the OC threshold.) It should be noted that a properly functioning overcurrent detector assumes the presence of a properly designed demodulation filter at the power-stage output. Short-circuit protection is not provided directly at the output pins of the power stage but only on the speaker terminals (after the demodulation filter). It is required to follow certain guidelines when selecting the OC threshold and an appropriate demodulation inductor:

OC-Adjust Resistor Values (k Ω)	Max. Current Before OC Occurs (A), $T_C=75^\circ\text{C}$
22	8.4 A
33	6.8 A
47	5.3 A

The reported max peak current in the table above is measured with continuous current in 1 Ω , one channel active and the other one muted.

Pin-To-Pin Short Circuit Protection System (PPSC)

The PPSC detection system protects the device from permanent damage in the case that a power output pin (OUT_X) is shorted to GND_X or PVDD_X. For comparison the OC protection system detects an over current after the demodulation filter where PPSC detects shorts directly at the pin before the filter. PPSC detection is performed at startup i.e. when VDD is supplied, consequently a short to either GND_X or PVDD_X after system startup will not activate the PPSC detection system. When PPSC detection is activated by a short on the output, all half bridges are kept in a Hi-Z state until the short is removed, the device then continues the startup sequence and starts switching. The detection is controlled globally by a two step sequence. The first step ensures that there are no shorts from OUT_X to GND_X, the second step tests that there are no shorts from OUT_X to PVDD_X. The total duration of this process is roughly proportional to the capacitance of the output LC filter. The typical duration is < 15 ms/ μ F. While the PPSC detection is in progress, $\overline{\text{SD}}$ is kept low, and the device will not react to changes applied to the $\overline{\text{RESET}}$ pins. If no shorts are present the PPSC detection passes, and $\overline{\text{SD}}$ is released. A device reset will not start a new PPSC detection.

PPSC detection is enabled in BTL and PBTL output configurations, the detection is not performed in SE mode. To make sure not to trip the PPSC detection system it is recommended not to insert resistive load to GND_X or PVDD_X.

Overtemperature Protection

The TAS5342L has a two-level temperature-protection system that asserts an active-low warning signal (\overline{OTW}) when the device junction temperature exceeds 125°C (nominal) and, if the device junction temperature exceeds 155°C (nominal), the device is put into thermal shutdown, resulting in all half-bridge outputs being set in the high-impedance (Hi-Z) state and \overline{SD} being asserted low. OTE is latched in this case. To clear the OTE latch, either $\overline{RESET_AB}$ or $\overline{RESET_CD}$ must be asserted. Thereafter, the device resumes normal operation.

Undervoltage Protection (UVP) and Power-On Reset (POR)

The UVP and POR circuits of the TAS5342L fully protect the device in any power-up/down and brownout situation. While powering up, the POR circuit resets the overload circuit (OLP) and ensures that all circuits are fully operational when the GVDD_X and VDD supply voltages reach stated in the Electrical Characteristics Table. Although GVDD_X and VDD are independently monitored, a supply voltage drop below the UVP threshold on any

VDD or GVDD_X pin results in all half-bridge outputs immediately being set in the high-impedance (Hi-Z) state and \overline{SD} being asserted low. The device automatically resumes operation when all supply voltages have increased above the UVP threshold.

DEVICE RESET

Two reset pins are provided for independent control of half-bridges A/B and C/D. When $\overline{RESET_AB}$ is asserted low, all four power-stage FETs in half-bridges A and B are forced into a high-impedance (Hi-Z) state. Likewise, asserting $\overline{RESET_CD}$ low forces all four power-stage FETs in half-bridges C and D into a high-impedance state. Thus, both reset pins are well suited for hard-muting the power stage if needed.

In BTL modes, to accommodate bootstrap charging prior to switching start, asserting the reset inputs low enables weak pulldown of the half-bridge outputs. In the SE mode, the weak pulldowns are not enabled, and it is therefore recommended to ensure bootstrap capacitor charging by providing a low pulse on the PWM inputs when reset is asserted high.

Asserting either reset input low removes any fault information to be signalled on the \overline{SD} output, i.e., \overline{SD} is forced high.

A rising-edge transition on either reset input allows the device to resume operation after an overload fault. To ensure thermal reliability, the rising edge of reset must occur no sooner than 4ms after the falling edge of \overline{SD} .

PACKAGING INFORMATION

Orderable Device	Status (1)	Package Type	Package Drawing	Pins	Package Qty	Eco Plan (2)	Lead finish/ Ball material (6)	MSL Peak Temp (3)	Op Temp (°C)	Device Marking (4/5)	Samples
TAS5342LDDV	NRND	HTSSOP	DDV	44	35	RoHS & Green	NIPDAU	Level-3-260C-168 HR	0 to 70	TAS5342L	
TAS5342LDDVR	NRND	HTSSOP	DDV	44	2000	RoHS & Green	NIPDAU	Level-3-260C-168 HR	0 to 70	TAS5342L	

(1) The marketing status values are defined as follows:

ACTIVE: Product device recommended for new designs.

LIFEBUY: TI has announced that the device will be discontinued, and a lifetime-buy period is in effect.

NRND: Not recommended for new designs. Device is in production to support existing customers, but TI does not recommend using this part in a new design.

PREVIEW: Device has been announced but is not in production. Samples may or may not be available.

OBSELETE: TI has discontinued the production of the device.

(2) **RoHS:** TI defines "RoHS" to mean semiconductor products that are compliant with the current EU RoHS requirements for all 10 RoHS substances, including the requirement that RoHS substance do not exceed 0.1% by weight in homogeneous materials. Where designed to be soldered at high temperatures, "RoHS" products are suitable for use in specified lead-free processes. TI may reference these types of products as "Pb-Free".

RoHS Exempt: TI defines "RoHS Exempt" to mean products that contain lead but are compliant with EU RoHS pursuant to a specific EU RoHS exemption.

Green: TI defines "Green" to mean the content of Chlorine (Cl) and Bromine (Br) based flame retardants meet JS709B low halogen requirements of <=1000ppm threshold. Antimony trioxide based flame retardants must also meet the <=1000ppm threshold requirement.

(3) MSL, Peak Temp. - The Moisture Sensitivity Level rating according to the JEDEC industry standard classifications, and peak solder temperature.

(4) There may be additional marking, which relates to the logo, the lot trace code information, or the environmental category on the device.

(5) Multiple Device Markings will be inside parentheses. Only one Device Marking contained in parentheses and separated by a "~" will appear on a device. If a line is indented then it is a continuation of the previous line and the two combined represent the entire Device Marking for that device.

(6) Lead finish/Ball material - Orderable Devices may have multiple material finish options. Finish options are separated by a vertical ruled line. Lead finish/Ball material values may wrap to two lines if the finish value exceeds the maximum column width.

Important Information and Disclaimer:The information provided on this page represents TI's knowledge and belief as of the date that it is provided. TI bases its knowledge and belief on information provided by third parties, and makes no representation or warranty as to the accuracy of such information. Efforts are underway to better integrate information from third parties. TI has taken and continues to take reasonable steps to provide representative and accurate information but may not have conducted destructive testing or chemical analysis on incoming materials and chemicals. TI and TI suppliers consider certain information to be proprietary, and thus CAS numbers and other limited information may not be available for release.

In no event shall TI's liability arising out of such information exceed the total purchase price of the TI part(s) at issue in this document sold by TI to Customer on an annual basis.

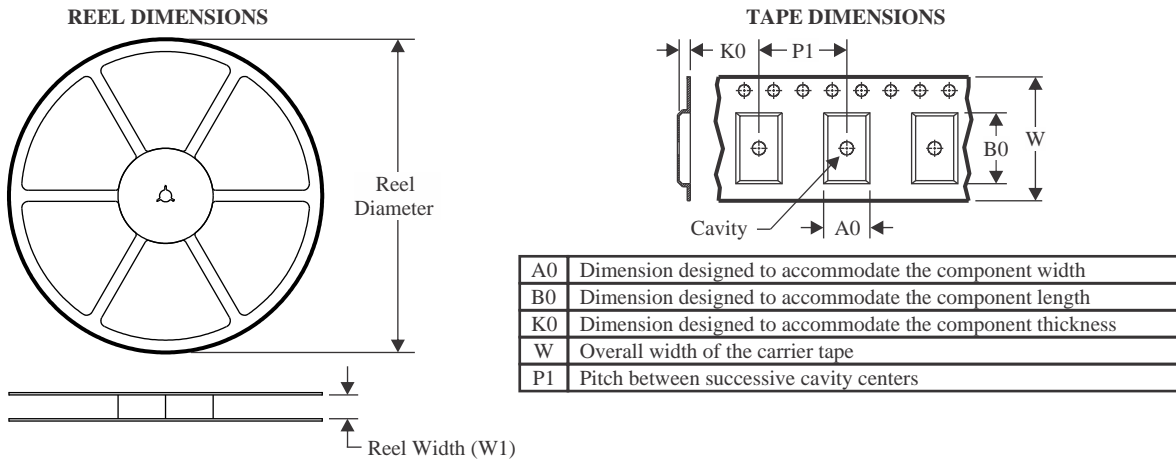
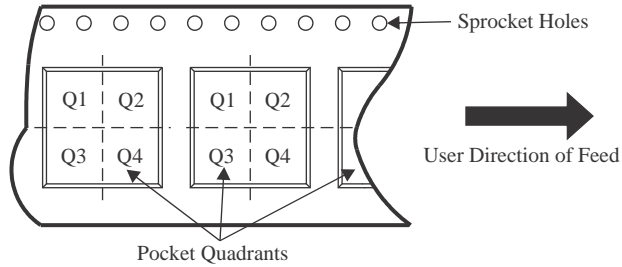
TAPE AND REEL INFORMATION

QUADRANT ASSIGNMENTS FOR PIN 1 ORIENTATION IN TAPE

*All dimensions are nominal

Device	Package Type	Package Drawing	Pins	SPQ	Reel Diameter (mm)	Reel Width W1 (mm)	A0 (mm)	B0 (mm)	K0 (mm)	P1 (mm)	W (mm)	Pin1 Quadrant
TAS5342LDDVR	HTSSOP	DDV	44	2000	330.0	24.4	8.6	15.6	1.8	12.0	24.0	Q1

TAPE AND REEL BOX DIMENSIONS

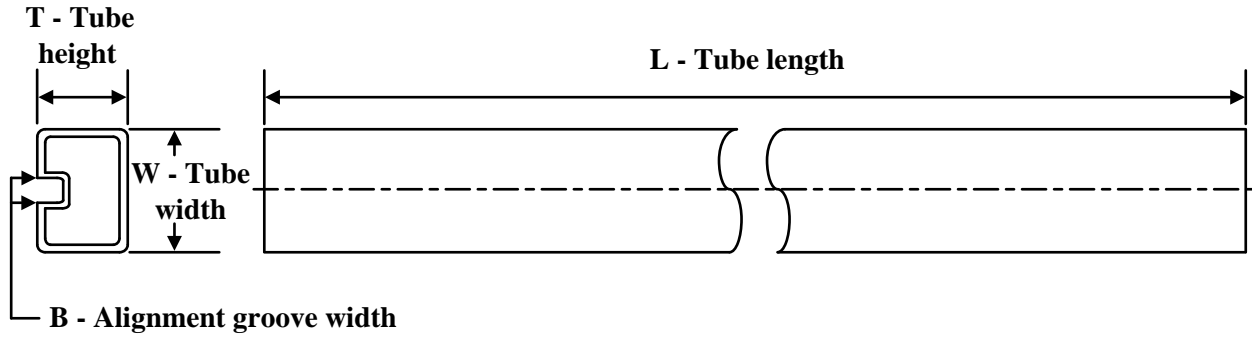

*All dimensions are nominal

Device	Package Type	Package Drawing	Pins	SPQ	Length (mm)	Width (mm)	Height (mm)
TAS5342LDDVR	HTSSOP	DDV	44	2000	350.0	350.0	43.0

TUBE

*All dimensions are nominal

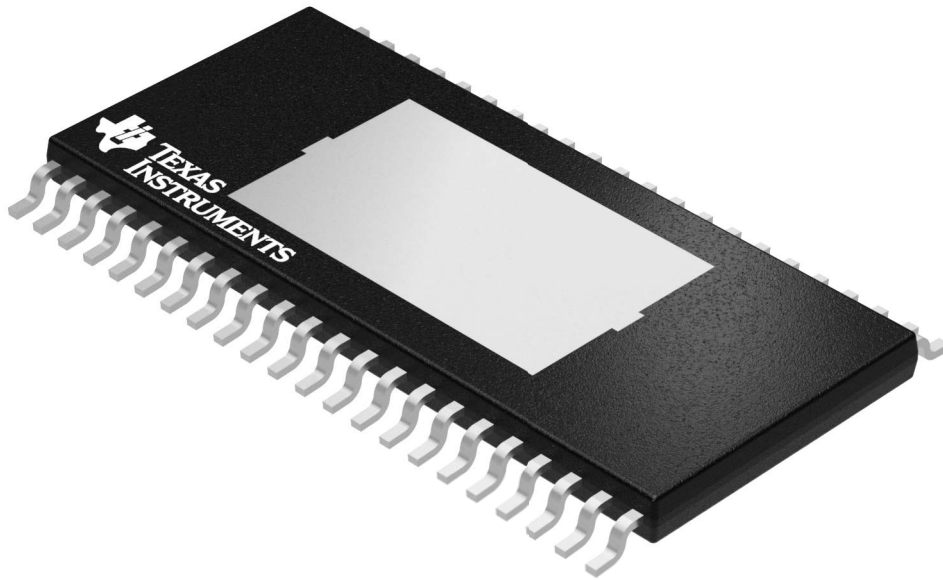
Device	Package Name	Package Type	Pins	SPQ	L (mm)	W (mm)	T (μm)	B (mm)
TAS5342LDDV	DDV	HTSSOP	44	35	530	11.89	3600	4.9



Images above are just a representation of the package family, actual package may vary.
Refer to the product data sheet for package details.

MECHANICAL DATA

DDV (R-PDSO-G44) PowerPAD™ PLASTIC SMALL OUTLINE PACKAGE (DIE DOWN)

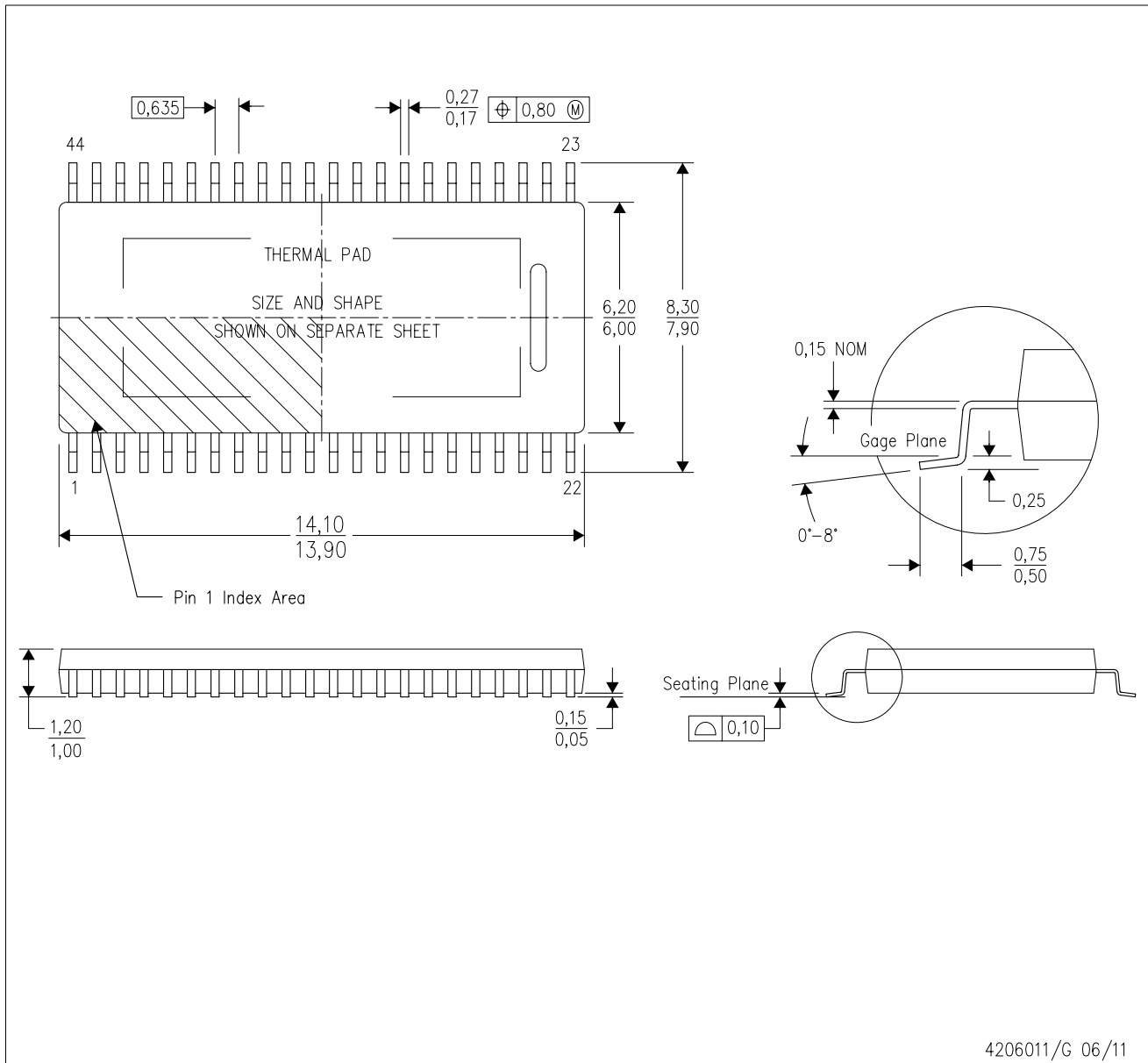

4206011/G 06/11

- NOTES:
- All linear dimensions are in millimeters. Dimensioning and tolerancing per ASME Y14.5M-1994.
 - This drawing is subject to change without notice.
 - Body dimensions do not include mold flash or protrusion not to exceed 0,15.
 - This package is designed to be attached directly to an external heatsink. Refer to Technical Brief, PowerPAD Thermally Enhanced Package, Texas Instruments Literature No. SLMA002 for information regarding recommended board layout. This document is available at www.ti.com <<http://www.ti.com>>. See the product data sheet for details regarding the exposed thermal pad dimensions.

PowerPAD is a trademark of Texas Instruments.

THERMAL PAD MECHANICAL DATA

DDV (R-PDSO-G44)

PowerPAD™ SMALL OUTLINE PACKAGE

THERMAL INFORMATION

This PowerPAD™ package incorporates an exposed thermal pad that is designed to be attached directly to an external heatsink. This design optimizes the heat transfer from the integrated circuit (IC).

For additional information on the PowerPAD package and how to take advantage of its heat dissipating abilities, refer to Technical Brief, PowerPAD Thermally Enhanced Package, Texas Instruments Literature No. SLMA002 and Application Brief, PowerPAD Made Easy, Texas Instruments Literature No. SLMA004. Both documents are available at www.ti.com.

The exposed thermal pad dimensions for this package are shown in the following illustration.

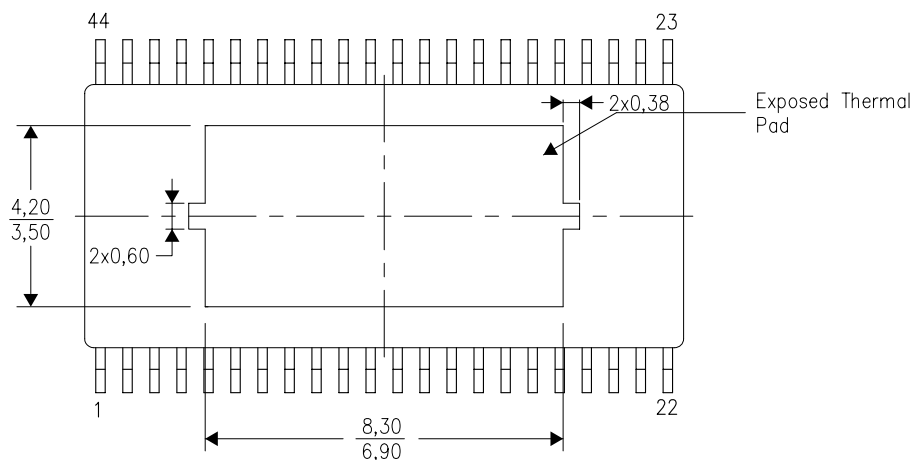

Top View

Exposed Thermal Pad Dimensions

4206975-2/D 07/11

NOTE: All linear dimensions are in millimeters

PowerPAD is a trademark of Texas Instruments

IMPORTANT NOTICE AND DISCLAIMER

TI PROVIDES TECHNICAL AND RELIABILITY DATA (INCLUDING DATA SHEETS), DESIGN RESOURCES (INCLUDING REFERENCE DESIGNS), APPLICATION OR OTHER DESIGN ADVICE, WEB TOOLS, SAFETY INFORMATION, AND OTHER RESOURCES "AS IS" AND WITH ALL FAULTS, AND DISCLAIMS ALL WARRANTIES, EXPRESS AND IMPLIED, INCLUDING WITHOUT LIMITATION ANY IMPLIED WARRANTIES OF MERCHANTABILITY, FITNESS FOR A PARTICULAR PURPOSE OR NON-INFRINGEMENT OF THIRD PARTY INTELLECTUAL PROPERTY RIGHTS.

These resources are intended for skilled developers designing with TI products. You are solely responsible for (1) selecting the appropriate TI products for your application, (2) designing, validating and testing your application, and (3) ensuring your application meets applicable standards, and any other safety, security, regulatory or other requirements.

These resources are subject to change without notice. TI grants you permission to use these resources only for development of an application that uses the TI products described in the resource. Other reproduction and display of these resources is prohibited. No license is granted to any other TI intellectual property right or to any third party intellectual property right. TI disclaims responsibility for, and you will fully indemnify TI and its representatives against, any claims, damages, costs, losses, and liabilities arising out of your use of these resources.

TI's products are provided subject to [TI's Terms of Sale](#) or other applicable terms available either on [ti.com](https://www.ti.com) or provided in conjunction with such TI products. TI's provision of these resources does not expand or otherwise alter TI's applicable warranties or warranty disclaimers for TI products.

TI objects to and rejects any additional or different terms you may have proposed.

Mailing Address: Texas Instruments, Post Office Box 655303, Dallas, Texas 75265
Copyright © 2023, Texas Instruments Incorporated

Looking for pricing, stock, or lifecycle information?

Click below to explore more details on WIN SOURCE:

⊖ [View TAS5342LDDV6EVM on WIN SOURCE](#)

⊖ [Texas Instruments](#) Information

Optimize Your Supply Chain with WIN SOURCE Solutions

- ✓ Global Sourcing Solution
- ✓ Obsolete Management
- ✓ Cost Control Management
- ✓ Shortage Management
- ✓ Alternative Solution
- ✓ Excess Inventory Management