



**THE DATASHEET OF
DA-REF105**



TAS3002

Digital Audio Processor With Codec

*Data
Manual*

1 Introduction

1.1 Description

The TAS3002 device is a system-on-a-chip that replaces conventional analog equalization to perform digital parametric equalization, dynamic range compression, and loudness contour. Additionally, this device provides high-quality, soft digital volume, bass, and treble control. All control parameters are uploaded from an outside MCU through the I²C slave port or from an external EEPROM through the I²C master port.

The TAS3002 device also has an integrated 24-bit stereo codec with two I²C-selectable, single-ended inputs per channel.

The digital parametric equalization consists of seven cascaded, independent biquad filters per channel. Each biquad filter has five 24-bit coefficients that can be configured into many different filter functions (such as band-pass, high-pass, and low-pass).

The internal loudness contour algorithm can be controlled and programmed with an I²C command.

Dynamic range compression/expansion (DRCE) is programmable through the I²C port. The system designer can set the threshold, energy estimation time constant, compression ratio, and attack and decay time constants.

The TAS3002 device supports 13 serial interface formats (I²S, left justified, right justified) with data word lengths of 16, 18, 20, or 24 bits. The sampling frequency (f_S) may be set to 32 kHz, 44.1 kHz, or 48 kHz. The 13 serial interface formats are listed and described in Section 2.1.

The TAS3002 device uses a system clock generated by the internal phase-locked loop (PLL). The reference clock for the PLL is provided by an external master clock (MCLK) of $256f_S$ or $512f_S$, or a $256f_S$ crystal.

The TAS3002 device has six internally configurable general-purpose input (GPI) terminals that control volume, bass, treble, and equalization. Each GPI terminal has a debounce algorithm that is programmed into the TAS3002 internal microcontroller.

1.2 Features

- Programmable seven-band parametric equalization
- Programmable digital volume control
- Programmable digital bass and treble control
- Programmable dynamic range compression/expansion (DRCE)
- Programmable loudness contour/dynamic bass control
- Configurable serial port for audio data
- Two input data channels that can be mixed with digital data from the analog-to-digital converter (ADC) of the codec (analog input). These channels are controlled by I²C commands.
- Three output data channels: Left and right data go through equalization; bass, treble, DRCE, and volume to SDOUT1; SDOUT2 mixes left and right data. SDOUT2 operates as a center channel or subwoofer channel. The output of the ADC is available for additional processing.
- Capability to digitally mix left and right input channels for a monaural output to facilitate subwoofer operation
- Serial I²C master/slave port that allows:
 - Downloading of control data to the device externally from the EEPROM or an I²C master
 - Controlling other I²C devices

- Two I²C-selectable, single-ended analog input stereo channels
- Equalization bypass mode
- Single 3.3-V power supply
- Power down without reloading the coefficients
- Sampling rates of 32 kHz, 44.1 kHz, or 48 kHz
- Master clock frequency of 256f_S or 512f_S
- Can have crystal input to replace MCLK. Crystal input frequency is 256f_S.
- Six GPI terminals for volume, bass, treble up/down control, mute, and selection of equalization filters

1.3 Functional Block Diagram

Figure 1–1 is a block diagram showing the major functions of the TAS3002.

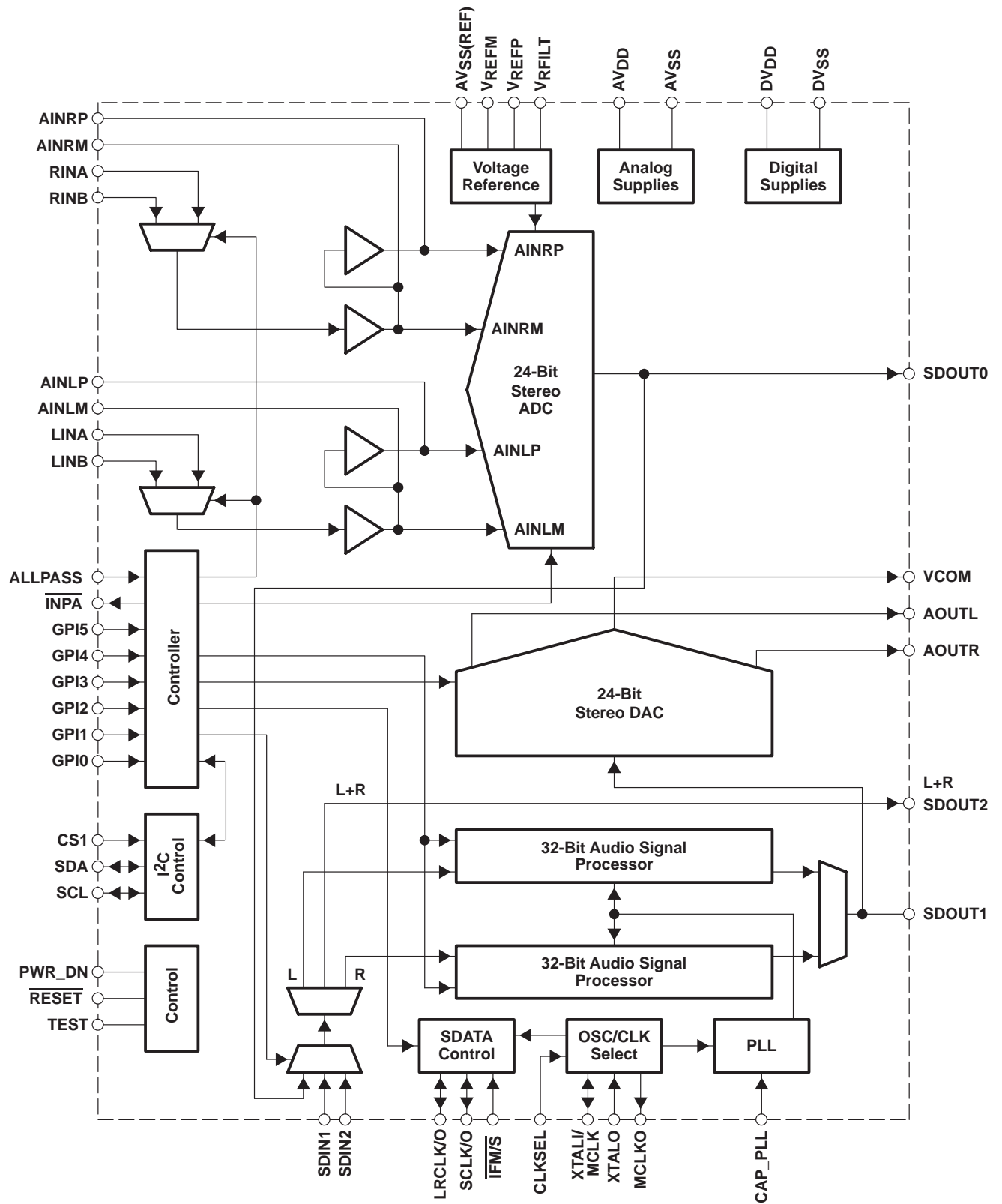

Figure 1-1. TAS3002 Block Diagram

1.4 Terminal Assignments

Figure 1–2 shows the terminal locations on the package outline, along with the signal name assigned to each terminal.

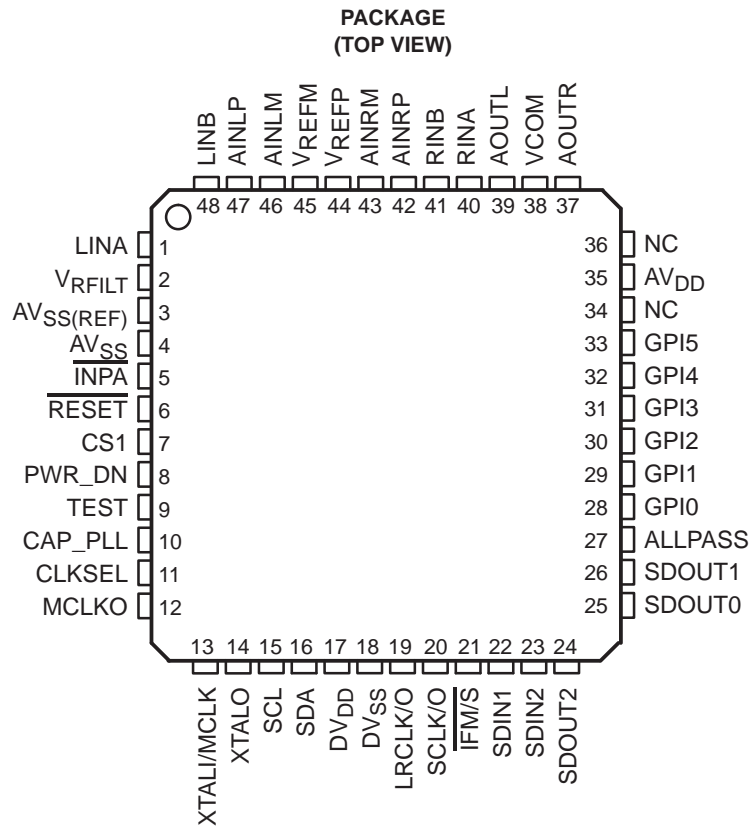

Figure 1–2. TAS3002 Terminal Assignments

1.5 Terminal Functions

Table 1–1 lists the terminals in alphanumeric order by signal name, along with the terminal number, terminal type, and a description of the terminal function.

Table 1–1. TAS3002 Terminal Functions

TERMINAL NAME	NO.	I/O	DESCRIPTION
AINLM	46	I	ADC left channel analog input (antialias capacitor)
AINLP	47	I	ADC left channel analog input (antialias capacitor)
AINRM	43	I	ADC right channel analog input (antialias capacitor)
AINRP	42	I	ADC right channel analog input (antialias capacitor)
ALLPASS	27	I	Logic high bypasses equalization filters
AOUTL	39	O	Left channel analog output
AOUTR	37	O	Right channel analog output
AVDD	35	I	Analog power supply (3.3 V)
AVSS	4	I	Analog voltage ground
AVSS(REF)	3	I	Analog ground voltage reference

Table 1–1. TAS3002 Terminal Functions (Continued)

TERMINAL NAME	NO.	I/O	DESCRIPTION
CAP_PLL	10	I	Loop filter for internal phase-locked loop (PLL)
CLKSEL	11	I	Logic low selects 256fs; logic high selects 512fs MCLK
CS1	7	I	I ² C address bit A0; low = 68h, high = 6Ah
DVDD	17	I	Digital power supply (3.3 V)
DVSS	18	I	Digital ground
GPI0 GPI1 GPI2 GPI3 GPI4 GPI5	28 29 30 31 32 33	I	Switch input terminals
IFM/S	21	I	Digital audio I/O control (low = input; high = output)
INPA	5	O	Low when analog input A is selected (will sink 4 mA)
LINA	1	I	Left channel analog input 1
LINB	48	I	Left channel analog input 2
LRCLK/O	19	I/O	Left/right clock input/output (output when IFM/S is high)
MCLKO	12	O	MCLK output for slave devices
NC	34		No connection; Can be used as a printed circuit board routing channel
NC	36		No connection; Can be used as a printed circuit board routing channel
PWR_DN	8	I	Logic high places the TAS3002 device in power-down mode
RESET	6	I	Logic low resets the TAS3002 device to the initial state
RINA	40	I	Right channel analog input 1
RINB	41	I	Right channel analog input 2
SCL	15	I/O	I ² C clock connection
SCLK/O	20	I/O	Shift (bit) clock input (output when IFM/S is high)
SDA	16	I/O	I ² C data connection
SDIN1	22	I	Serial data input 1
SDIN2	23	I	Serial data input 2
SDOUT0	25	O	Serial data output from ADC
SDOUT1	26	O	Serial data output (from internal audio processing)
SDOUT2	24	O	Serial data output (a monaural mix of left and right, before processing)
TEST	9	I	Reserved manufacturing test terminal; connect to DVSS
VCOM	38	O	Digital-to-analog converter mid-rail supply (decouple with parallel combination of 10-μF and 0.1-μF capacitors)
VREFM	45	I	ADC minus voltage reference
VREFP	44	I	ADC plus voltage reference
VRFILT	2	O	Voltage reference low pass filter
XTALI/MCLK	13	I	Crystal or external MCLK input
XTALO	14	I	Crystal input (crystal is connected between terminals 13 and 14)

2 Audio Data Formats

2.1 Serial Interface Formats

The TAS3002 device works in master or slave mode.

In the master mode, terminal 21 ($\overline{\text{IFM/S}}$) is tied high. This activates the master clock (MCLK) circuitry. A crystal can be connected across terminals 13 (XTALI/MCLK) and 14 (XTALO), or an external, TTL-compatible MCLK can be connected to XTALI/MCLK. In that case, MCLK is outputs on terminal 12 (MCLKO), with terminals 19 (LRCLK/O) and 20 (SCLK/O) becoming outputs to drive slave devices.

In the slave mode, $\overline{\text{IFM/S}}$ is tied low. LRCLK/O and SCLK/O are inputs and the interface operates as a slave device requiring externally supplied MCLK, LRCLK (left/right clock), and SCLK (shift clock) inputs. There are two options for selecting the clock rates. If the $512f_S$ MCLK rate is selected, terminal 11 (CLKSEL) is tied high and an MCLK rate of $512f_S$ must be supplied. If the $256f_S$ MCLK is selected, CLKSEL is tied low and an MCLK of $256f_S$ must be supplied. In both cases, an LRCLK of 64SCLK must be supplied.

- MCLK and SCLK must be synchronous and their edges must be at least 3 ns apart.
- If the LRCLK phase changes by more than 10 cycles of MCLK, the codec automatically resets.

The TAS3002 device is compatible with 13 different serial interfaces. Available interface options are I²S, right justified, and left justified. Table 2–1 indicates how the 13 options are selected using the I²C bus and the main control register (MCR, I²C address 01h). All serial interface options at either 16, 18, 20, or 24 bits operate with SCLK at $64f_S$. Additionally, the 16-bit mode operates at $32f_S$.

Table 2–1. Serial Interface Options

MODE	MCR BIT (6)	MCR BIT (5–4)	MCR BIT (1–0)	SERIAL INTERFACE SDIN1, SDIN2, SDOUT1, SDOUT2, AND SDOUT0
0	0	00	00	16-bit, $32f_S$
1	1	00	00	16-bit, left justified, $64f_S$
2	1	01	00	16-bit, right justified, $64f_S$
3	1	10	00	16-bit, I ² S, $64f_S$
4	1	00	01	18-bit, left justified, $64f_S$
5	1	01	01	18-bit, right justified, $64f_S$
6	1	10	01	18-bit, I ² S, $64f_S$
7	1	00	10	20-bit, left justified, $64f_S$
8	1	01	10	20-bit, right justified, $64f_S$
9	1	10	10	20-bit, I ² S, $64f_S$
10	1	00	11	24-bit, left justified, $64f_S$
11	1	01	11	24-bit, right justified, $64f_S$
12	1	10	11	24-bit, I ² S, $64f_S$

Figure 2–1 through Figure 2–3 illustrate the relationship between the SCLK, LRCLK, and the serial data I/O for the different interface protocols.

2.2 Digital Output Modes

The digital output modes (SDOUT1, SDOUT2, SDOUT0) are described in Sections 2.2.1 through 2.2.3.

2.2.1 MSB-First, Right-Justified, Serial-Interface Format

The normal output mode for the MSB-first, right-justified, serial-interface format is for 16, 18, 20, or 24 bits. Figure 2–1 shows the following characteristics of this protocol:

- Left channel is transmitted when LRCLK is high.
- The SDIN(s) (recorded) data is justified to the trailing edge of the LRCLK.
- The SDOUT(s) MSB (playback) data is transmitted at the same time as LRCLK edge and captured at the next rising edge of SCLK.
- If the LRCLK phase changes by more than 10 cycles of MCLK, the codec automatically resets.

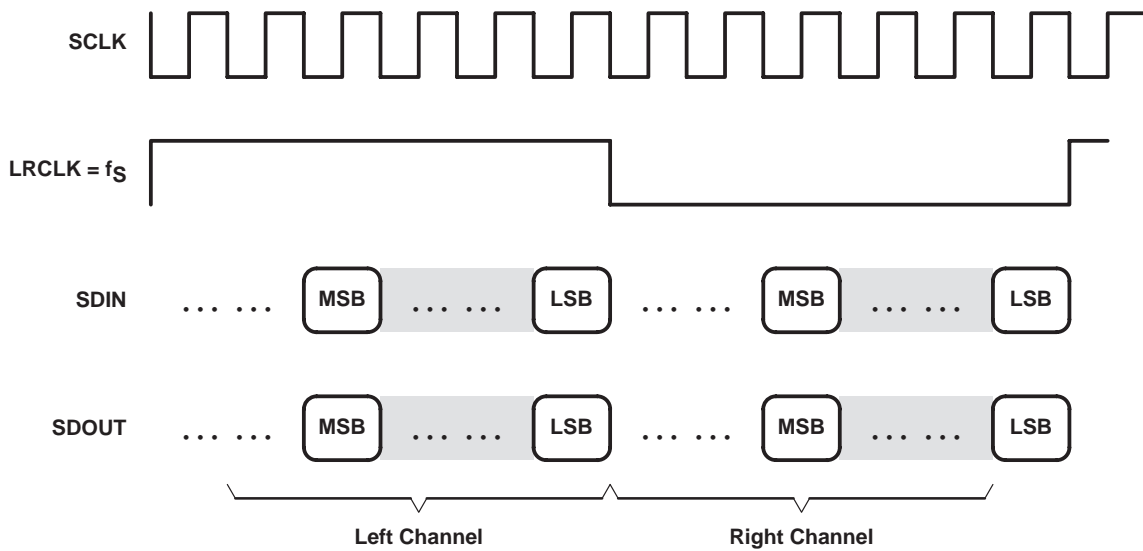

Figure 2–1. MSB-First, Right-Justified, Serial-Interface Format

2.2.2 I²S Serial-Interface Format

The normal output mode for the I²S serial-interface format is for 16, 18, 20, or 24 bits.

Figure 2–2 shows the following characteristics of this protocol:

- Left channel is transmitted when LRCLK is low.
- SDIN is sampled with the rising edge of SCLK.
- SDOUT is transmitted on the falling edge of SCLK.
- If the LRCLK phase changes by more than 10 cycles of MCLK, the codec automatically resets.

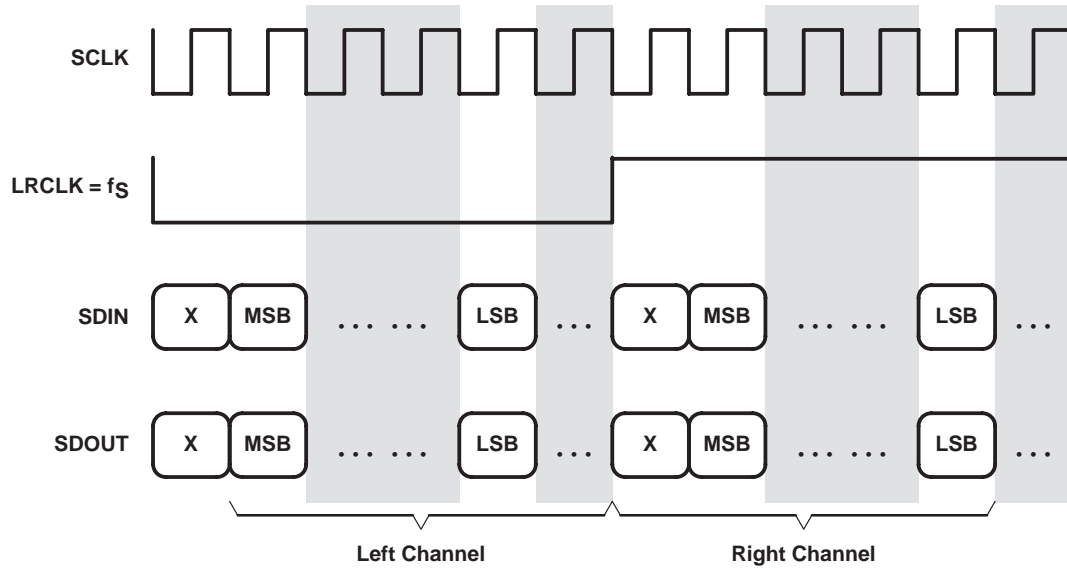

Figure 2–2. I²S Serial-Interface Format

2.2.3 MSB-Left-Justified, Serial-Interface Format

The normal output mode for the MSB-left-justified, serial-interface format is for 16, 18, 20, or 24 bits.

Figure 2–3 shows the following characteristics of this protocol:

- Left channel is transmitted when LRCLK is high.
- The SDIN data is justified to the leading edge of the LRCLK.
- The MSBs are transmitted at the same time as LRCLK edge and captured at the next rising edge of SCLK.

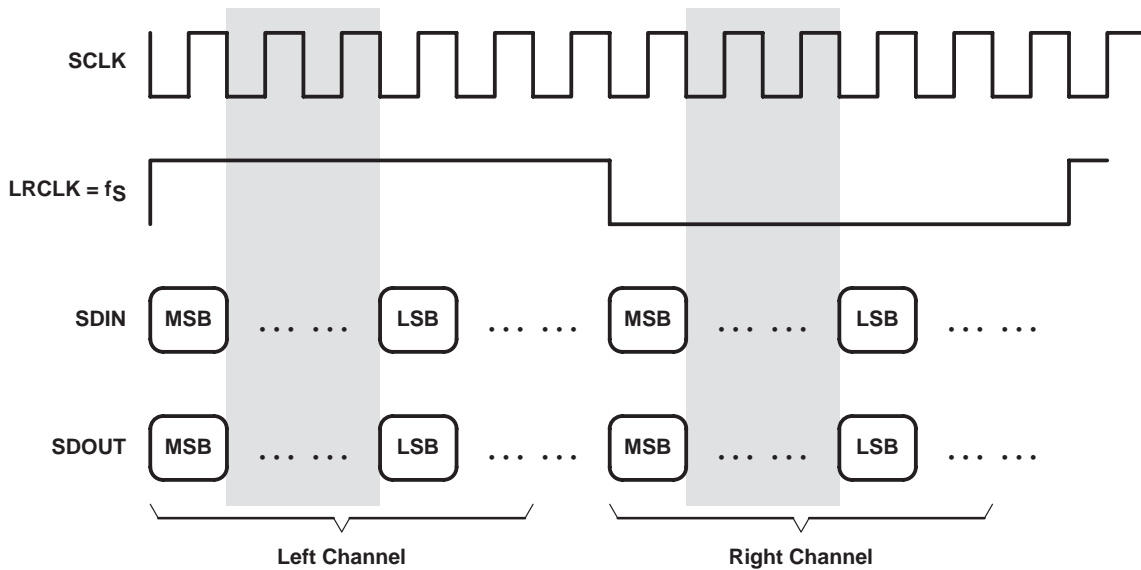

Figure 2–3. MSB-Left-Justified, Serial-Interface Format

2.3 Switching Characteristics

PARAMETER		MIN	TYP	MAX	UNIT
$t_c(\text{SCLK})$	SCLK cycle time	325.5			ns
$t_d(\text{SLR})$	SCLK rising to LRCLK edge	20			ns
$t_d(\text{SDOUT})$	SDOUT valid from SCLK falling edge (see Note 1)			$(1/256f_S) + 10$	ns
$t_{su}(\text{SDIN})$	SDIN setup before SCLK rising edge	20			ns
$t_h(\text{SDIN})$	SDIN hold after SCLK rising edge	100			ns
$f(\text{LRCLK})$	LRCLK frequency	32	44.1	48	kHz
	Duty cycle		50		%

NOTE 1: Maximum of 50-pF external load on SDOUT.

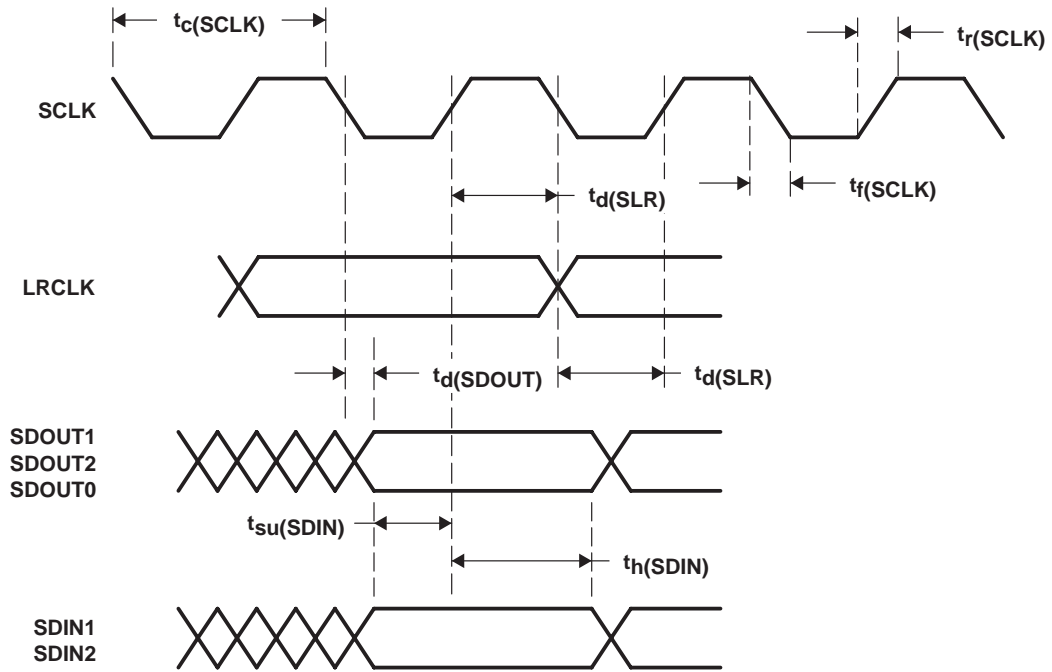

Figure 2-4. For Right-/Left-Justified and I²S Serial Protocols

3 Analog Input/Output

The TAS3002 device contains a stereo 24-bit ADC with two single-ended inputs per channel. Selection of the A or B analog input is accomplished by setting a bit in the analog control register (ACR) by an I²C command. Additionally, the TAS3002 device has a stereo 24-bit digital-to-analog converter (DAC).

3.1 Analog Input

Figure 3–1 shows the technique and components required for analog input to the TAS3002 device. The maximum input signal must not exceed 0.7 V_{rms}. Selection of the above component values gives a frequency response from 20 Hz to 20 kHz at a sampling frequency of 48 kHz without alias frequency problems.

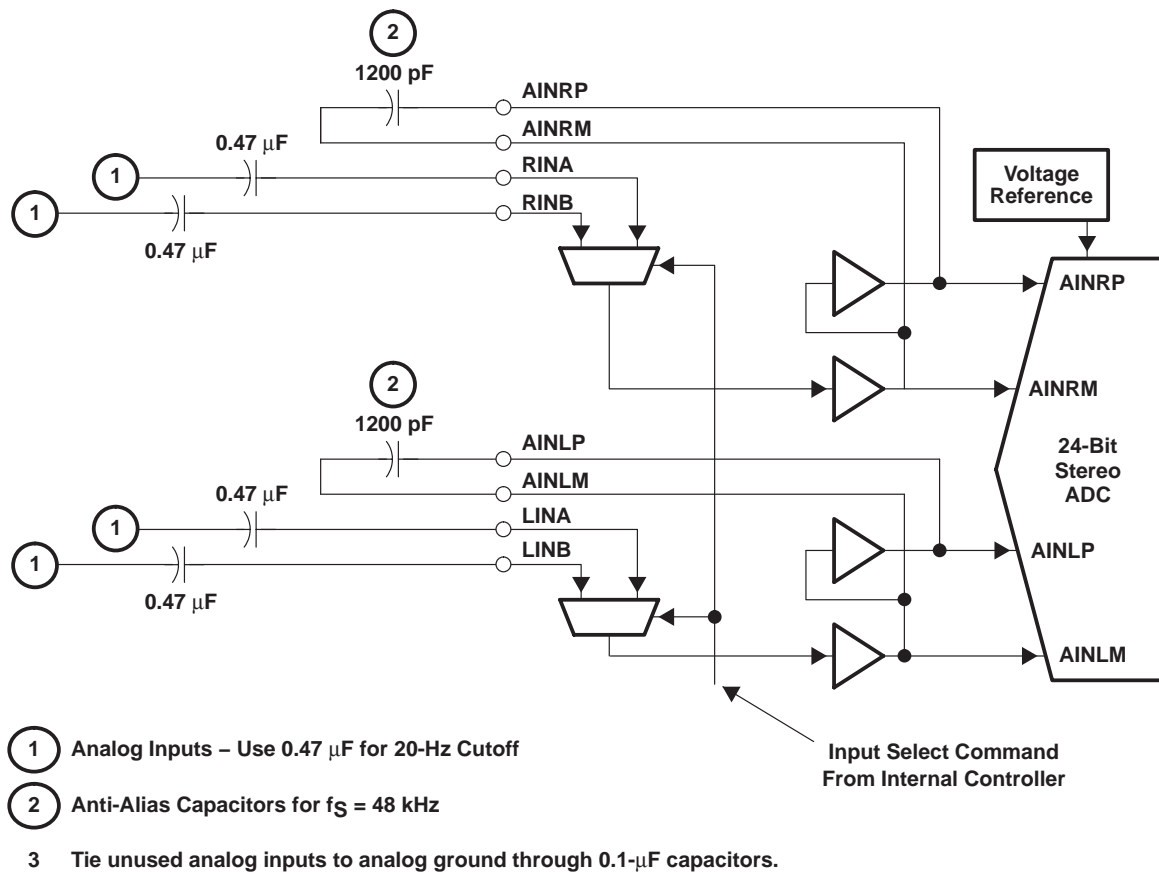

Figure 3–1. Analog Input to the TAS3002 Device

3.2 Analog Output

3.2.1 Direct Analog Output

The full scale analog output from the TAS3002 device is 0.707 V_{rms}. It is referenced to VCOM which is approximately 1.5 Vdc. VCOM must be decoupled with the network shown in Figure 3–2.

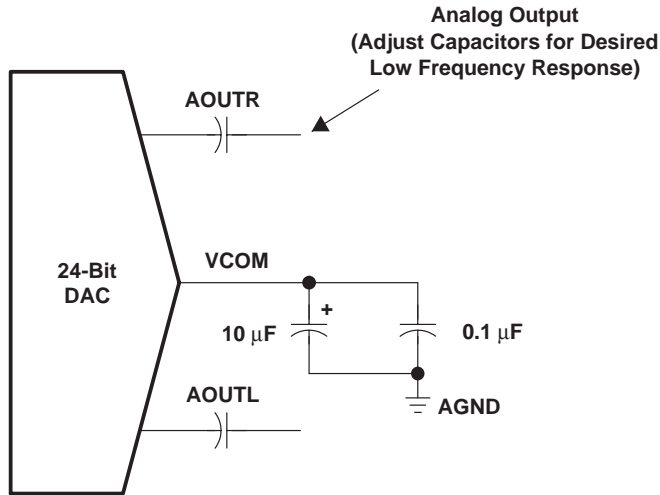

Figure 3-2. VCOM Decoupling Network

3.2.2 Analog Output With Gain

Because the maximum analog output from the TAS3002 device is $0.707 V_{rms}$, the output level can be increased by using an external amplifier. The circuit shown in Figure 3-3 boosts the output level to $1 V_{rms}$ (when it has a gain of 1.414) and provides improved signal-to-noise ratio (SNR). Since this circuit lowers the noise floor, THD + N is improved also.

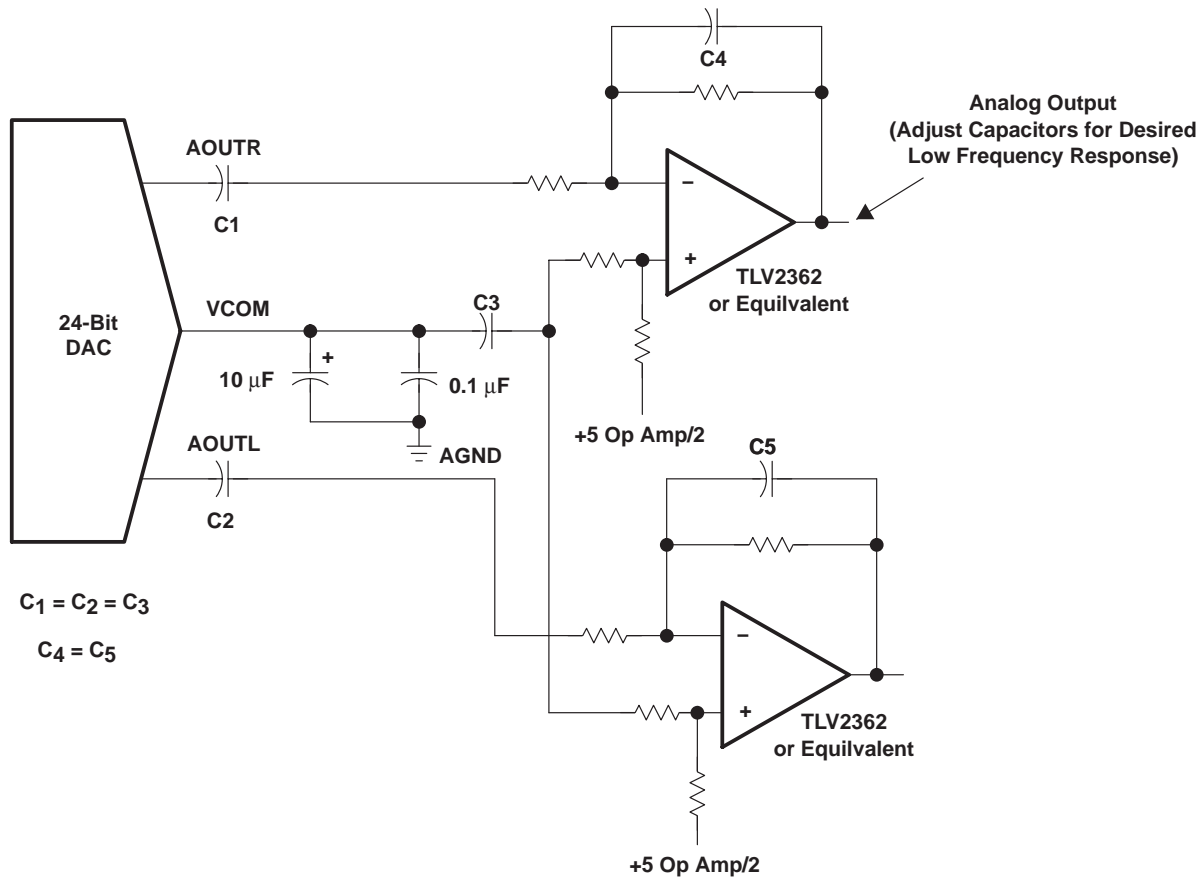

Figure 3-3. Analog Output With External Amplifier

3.2.3 Reference Voltage Filter

Figure 3–4 shows the TAS3002 reference voltage filter.

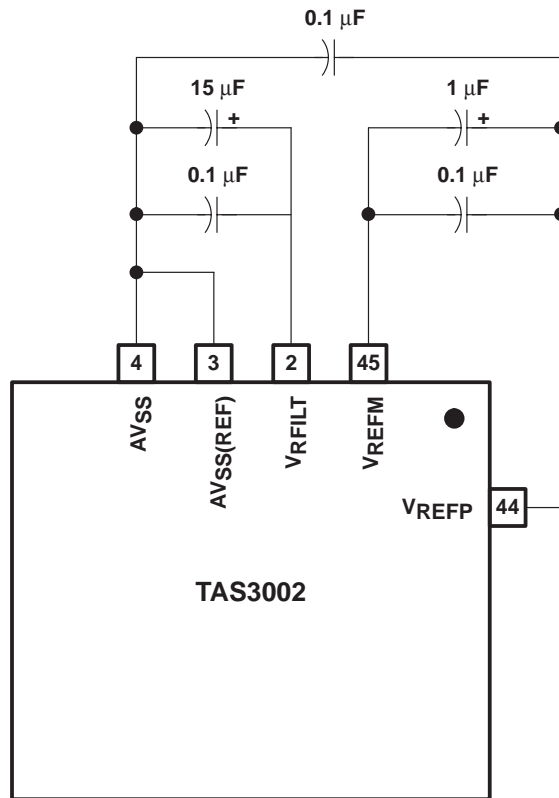

Figure 3–4. TAS3002 Reference Voltage Filter

4 Audio Control/Enhancement Functions

4.1 Soft Volume Update

The TAS3002 device implements a TI proprietary soft volume update. This feature allows a smooth and pleasant-sounding change from one volume level to another over the entire range of volume control (18 dB to mute).

The volume is adjustable by downloading a gain coefficient through the I²C interface in 4.16 format—4 bits for the integer and 16 bits for the fractional part. NO TAG lists the 4.16 coefficients converted into dB for the range of –70 dB to 18 dB with 0.5-dB step resolution.

Right and left channel volumes can be ungang and set to different values. This feature implements a balance control.

Volume is changed by writing the desired value into the volume control registers. This is done by asserting the volume-up or volume-down GPI terminal (see Section 7.6.1) for a limited range of volume control. Alternatively, volume control settings can be sent to the TAS3002 device over the I²C bus.

4.2 Software Soft Mute

Soft mute is implemented by loading all zeros in the volume control register. This causes the volume to ramp down over a duration of $2048f_s$ samples to a final output of 0 (– infinity dB).

Soft mute can be enabled by either asserting the mute GPI terminal (see Section 7.6.1) or sending a mute command over the I²C bus. Subsequent assertions of the mute GPI terminal toggle soft mute off and on.

4.3 Input Mixer Control

The TAS3002 device is capable of mixing and multiplexing three channels (SDIN1, SDIN2, and the ADC output) of serial audio data. The mixing is controlled through three mixer control registers. This is accomplished by loading values into the corresponding bytes of the mixer left gain (07h) and mixer right gain (08h) control registers. See Figure 4–1 for a functional block diagram of the input mixer.

The values loaded into these registers are in 4.20 format—4 bits for the integer and 20 bits for the fractional part. NO TAG lists the 4.20 numbers converted into dB for the range of –70 dB to 18 dB, although any positive 4.20 number may be used.

To mute any of the channels, 0s are loaded into the respective mixer control register.

Mixer controls are updated instantly and can cause audible artifacts for large changes in setting when updated dynamically outside of the fast load mode; therefore, it is desirable to use fast load in conjunction with the soft-volume mode.

SDIN1, SDIN2, and the ADC output can be mixed with a user-selectable gain for each channel. The gain control registers are represented in 4.20 format.

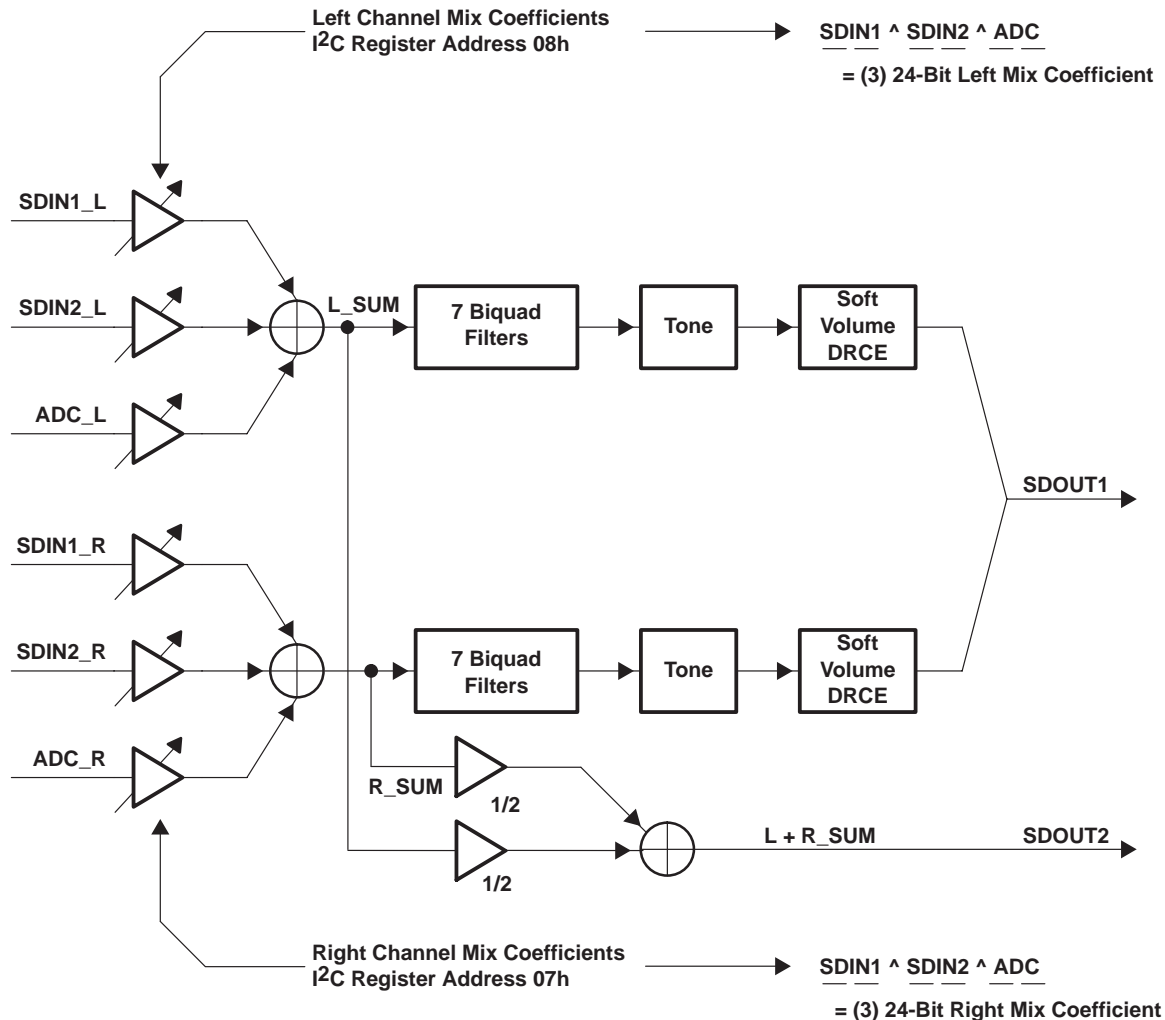

Figure 4–1. TAS3002 Mixer Function

4.4 Mono Mixer Control

The TAS3002 device contains a second mixer that performs the function of mixing left and right channel digital audio data from the input mixer in order to derive a monaural channel. This mixer has a fixed gain of –6 dB so that full scale inputs on L_sum and R_sum do not produce clipping on the resulting L+R_sum.

The output of this mixer is present on terminal 24 (SDOUT2) and is generally used for a digitally-mixed subwoofer or center channel application.

4.5 Treble Control

The treble gain level may be adjusted within the range of 15 dB to –15 dB with 0.5-dB step resolution. The level changes are accomplished by downloading treble codes (shown in NO TAG) into the treble gain register. Alternatively, a limited range of treble control is available by asserting the treble-up or treble-down GPI terminal (see Section 7.6.1).

The treble control has a corner frequency of 6 kHz at a 48-kHz sample rate.

The gain values for treble control can be found in Section NO TAG.

4.6 Bass Control

The bass gain level can be adjusted within the range of 15 dB to –15 dB with 0.5-dB step resolution. The level changes are accomplished by downloading bass codes (shown in NO TAG) into the bass frequency control register. Alternatively, a limited range of bass control is available by asserting the bass-up or bass-down GPI terminal (see Section 7.6.1).

Bass control is a shelf filter with a corner frequency of 250 Hz at a 48-kHz sample rate.

The gain values for bass control can be found in Section NO TAG.

4.7 De-Emphasis Mode (DM)

De-emphasis is implemented in the DAC and is software controlled. De-emphasis is valid at 44.1 kHz and 48 kHz.

To enable de-emphasis, values are written into the analog control register via the I²C command. See Section 4.8 for analog control register operation.

Figure 4–2 illustrates the frequency response of the de-emphasis mode.

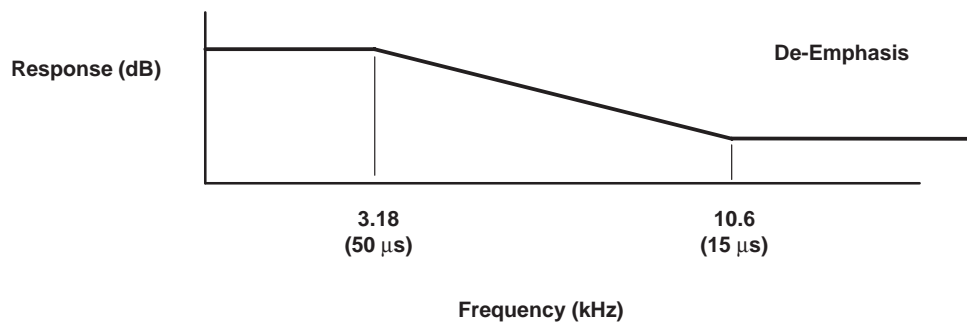

Figure 4–2. De-Emphasis Mode Frequency Response

4.8 Analog Control Register (40h)

The analog control register (ACR) allows control of de-emphasis, selection of the analog input channel to the ADC, and analog power down.

An I²C master is required to write the appropriate command into the ACR. The ACR subaddress is 40h.

Bit	7	6	5	4	3	2	1	0
Type	R/W	R/W	R/W	R/W	R/W	R/W	R/W	R/W
Default	0	0	0	0	0	0	0	0

Table 4–1. Analog Control Register Description

BIT	FIELD NAME	TYPE	DESCRIPTION
7	Reserved	R/W	Reset to 0
6	Reserved	R/W	Reset to 0
5–4	Reserved	R/W	Reserved. Bits 5 and 4 return 0s when read.
3–2	DM(1–0)	R/W	De-emphasis control 00 = De-emphasis off (initial condition after reset) 01 = 48 kHz sample rate de-emphasis selected 10 = 44.1 kHz sample rate de-emphasis selected 11 = Reserved
1	INP	R/W	Analog input select 0 = LINA and RINA selected (initial condition after reset) 1 = LINB and RINB selected
0	APD	R/W	Analog power down 0 = Normal operation (initial condition after reset) 1 = Power down

4.9 Dynamic Loudness Contour

The necessity for applying loudness compensation to playback systems to compensate for the fact that the ear perceives bass and treble less audibly at low levels than at high ones has been established since the first data was published by Fletcher and Munson in 1933.

There are many equal-loudness contours in publication, like Steven's contours, Robinson and Dadson contours. Some have even reached the acceptance level of ISO recommendation.

The TAS3002 device has a simplified loudness contour algorithm that diminishes the effect of weak bass at low listening levels. Since contour has volume level dependency, the user must define the relation between the gain of the contour circuit and the volume level.

Figure 4–3 is a block diagram of this circuit.

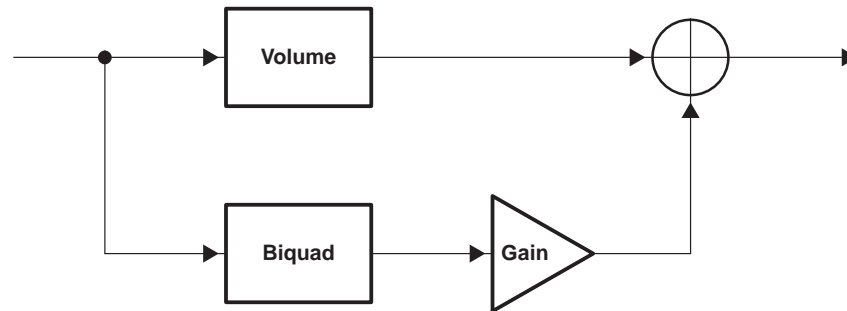

Figure 4–3. Dynamic Loudness Contour Block Diagram

The loudness contour is activated by sending an activation command via I²C from an external device. Optionally, a contour gain command can be sent by an external device to provide tracking with the system volume control.

4.9.1 Loudness Biquads

Loudness biquad filters for the left and right channels are independently programmable via I²C. Their subaddresses are 21h and 22h, respectively. The digital filters are written as five 24-bit (4.20) hex coefficients for each channel.

4.9.2 Loudness Gain

Loudness gain values for the left and right channels are independently programmable via I²C. Their subaddresses are 23h and 24h, respectively. The gain values are written as one 4.20 hex coefficient for each channel.

4.9.3 Loudness Contour Operation

When the frequency of the loudness contour is determined, a digital filter must be developed. Then, the gain of the filter is determined. These values are placed in the storage area of the system controller (microcontroller) and sent to the TAS3002 device when it is desired to activate the loudness contour.

If it is necessary to change the frequency or gain of the contour, new gain and filter coefficients are sent by the system controller. This function is performed normally when the volume control is changed (that is, more volume, less contour). The gain of the loudness contour filter then tracks the volume control.

The loudness contour biquad filters are provided in addition to the seven equalization biquad filters.

See Section NO TAG for programming instructions.

4.10 Dynamic Range Compression/Expansion (DRCE)

The TAS3002 device provides the user with the ability to manage the dynamic range of the audio system. The DRCE receives data, and affects scaling after the volume/loudness block. As shown in Figure 4–4, the DRCE is applied after the volume/loudness control block as a DRCE scale factor. The DRCE must be adjusted such that the signal does not reach the hard limit value. However, if the signal does reach the maximum digital value, the saturation logic serves as a hard limiter that does not allow the signal to extend beyond the available range.

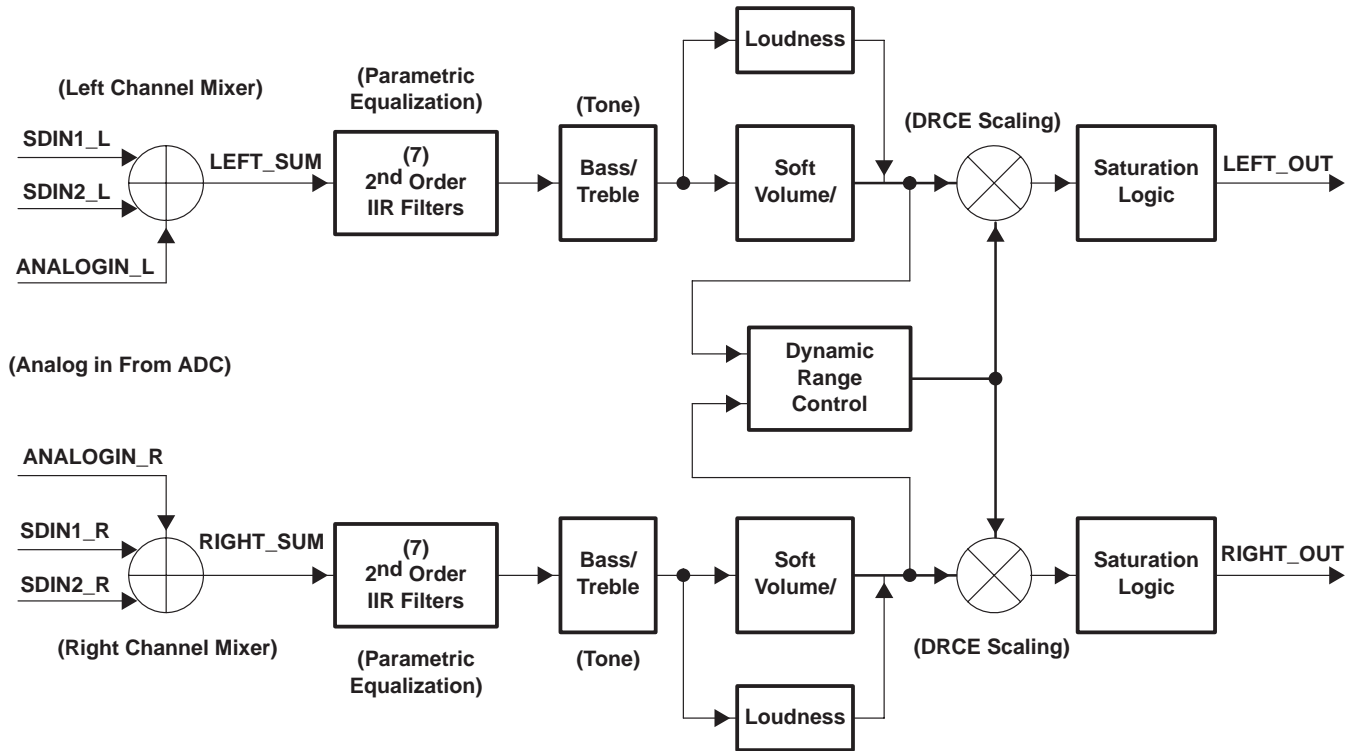

Figure 4–4. TAS3002 Digital Signal Processing Block Diagram

The DRCE instruction consists of eight bytes that must be sent each time in the order shown in the example code of NO TAG. Each instruction downloaded must be eight bytes. If only one byte is changed, all eight bytes must be transmitted. The first two bytes remain the same for every instruction, however the last six bytes can be programmed using hexadecimal values from the corresponding tables referred to in Section NO TAG.

With high compression ratios and fast attack times available, this function is suited for a *commercial killer* in a television set application.

4.11 AllPass Function

This function is enabled by setting terminal 27 (ALLPASS) on the TAS3002 device to 1. When asserted, the internal equalization filters are set into AllPass (flat) mode. When this terminal is reset to 0, the equalization filters are returned to the equalization that was in use before the terminal was asserted.

In AllPass mode, the bass and treble controls are still functional.

This function is frequently used for headphones. When the headphone plug is inserted into its jack, a switched contact in the jack enables the AllPass function.

The AllPass function also can be activated by writing a 1 to bit 2 of the analog control register.

4.12 Main Control Register 1 (01h)

The TAS3002 device contains two main control registers: main control register 1 (MCR1) and main control register 2 (MCR2). The MCR1 register contains the bits associated with load speed, SCLK frequency, serial-port mode, and serial-port word length. It is accessed via I²C with the address 01h.

MCR1 (01h)

Bit	b7	b6	b5	b4	b3	b2	b1	b0
Type	R/W	R/W	R/W	R/W	R	R	R/W	R/W
Default	1	X	X	X	X	X	X	X

Table 4–2. Main Control Register 1 Description

BIT	FIELD NAME	TYPE	DESCRIPTION
7	FL	R/W	Fast load 0 = Normal operation mode 1 = Fast -load mode (default)
6	SC	R/W	SCLK frequency 0 = SCLK is 32 f _S . 1 = SCLK is 64 f _S .
5–4	E	R/W	Serial port mode 00 = Left justified 01 = Right justified 10 = I ² S 11 = Reserved
3–2	Reserved	R	Reserved
1–0	W	R/W	Serial port word length 00 = 16-bit 01 = 18-bit 10 = 20-bit 11 = 24-bit

4.13 Main Control Register 2 (43h)

The TAS3002 device contains two main control registers: main control register 1 (MCR1) and main control register 2 (MCR2). The MCR2 register contains the bits associated with the AllPass function and the download of bass and treble control information, and it is accessed via I²C with the address 43h.

MCR2 (43h)

Bit	7	6	5	4	3	2	1	0
Type	R/W	R	R	R	R	R	R/W	R
Default	0	0	0	x	x	x	0	0

Table 4–3. Main Control Register 2 Description

BIT	FIELD NAME	TYPE	DESCRIPTION
7	Reserved	R/W	0 = Normal operation (initial condition after reset) 1 = Download bass and treble
6–5	Reserved	R	Reserved. Bits 6 and 5 return 0s when read.
4–2	Reserved	R	Undefined.
1	DM(1–0)	R/W	0 = Normal operation (initial condition after reset) 1 = AllPass mode (bass and treble are still functional)
0	INP	R	Reserved. Bit 0 returns 0 when read.

5 Filter Processor

5.1 Biquad Block

The biquad block consists of seven digital biquad filters per channel organized in a cascade structure, as shown in Figure 5–1. Each of these biquad filters has five downloadable 24-bit (4.20) coefficients. Each stereo channel has independent coefficients.



Figure 5–1. Biquad Cascade Configuration

5.1.1 Filter Coefficients

The filter coefficients for the TAS3002 device are downloaded through the I²C port and loaded into the biquad memory space. Each biquad filter memory space has an independent address. Digital audio data coming into the device is processed by the biquad block and then converted into analog waveforms by the DAC. Alternatively, filters can be loaded by asserting terminals on the GPI port.

5.1.2 Biquad Structure

The biquad structure that is used for the parametric equalization filters is as follows:

$$H(z) = \frac{b_0 + b_1z^{-1} + b_2z^{-2}}{a_0 + a_1z^{-1} + a_2z^{-2}} \quad (1)$$

NOTE: a_0 is fixed at value 1 and is not downloadable.

The coefficients for these filters are represented in 4.20 format—4 bits for the integer part and 20 bits for the fractional part. In order to transmit them over I²C, it is necessary to separate each coefficient into three bytes. The upper 4 bits of byte 2 comprise the integer part; the lower 4 bytes of byte 2 plus byte 1 and byte 0 comprise the fractional part.

The filters can be designed using the automatic loudspeaker equalization program (ALE) or a script running under MatLab named Filtermaker. Both of these tools are available from Texas Instruments.

6 I²C Serial Control Interface

6.1 Introduction

Control parameters for the TAS3002 device can be loaded from an I²C serial EEPROM by using the TAS3002 master interface mode. If no EEPROM is found, the TAS3002 device becomes a slave device and loads from another I²C master interface. Information loaded into the TAS3002 registers is defined in Appendix A.

The I²C bus uses terminals 16 (SDA for data) and 15 (SCL for clock) to communicate between integrated circuits in a system. These devices can be addressed by sending a unique 7-bit slave address plus R/W bit (1 byte). All compatible devices share the same terminals via a bidirectional bus using a wired-AND connection. An external pullup resistor must be used to set the high level on the bus. The TAS3002 device operates in standard mode up to 100 kbps with as many devices on the bus as desired up to the capacitance load limit of 400 pF.

Furthermore, the TAS3002 device supports a subset of the SMBus protocol. When it is attached to the SMBus, then byte, word, and block transfers are supported. The SMBus NAK function is not supported and care must be taken with the sequence of the instructions sent to the TAS3002 device.

Additionally, the TAS3002 device operates in either master or slave mode; therefore, at least one device connected to the I²C bus must operate in master mode.

6.2 I²C Protocol

The bus standard uses transitions on SDA while the clock is high to indicate start and stop conditions. A high-to-low transition on SDA indicates a start and a low-to-high transition indicates a stop. Normal data bit transitions must occur within the low time of the clock period. Figure 6–1 shows these conditions. These start and stop conditions for the I²C bus are required by standard protocol to be generated by the master. The master must also generate the 7-bit slave address and the read/write (R/W) bit to open communication with another device and then wait for an acknowledge condition. The slave holds SDA low during acknowledge clock period to indicate an acknowledgment. When this occurs, the master transmits the next byte of the sequence.

After each 8-bit word, an acknowledgment must be transmitted by the receiving device. There is no limit on the number of bytes that can be transmitted between start and stop conditions. When the last word transfers, the master generates a stop condition to release the bus. Figure 6–1 shows a generic data transfer sequence.

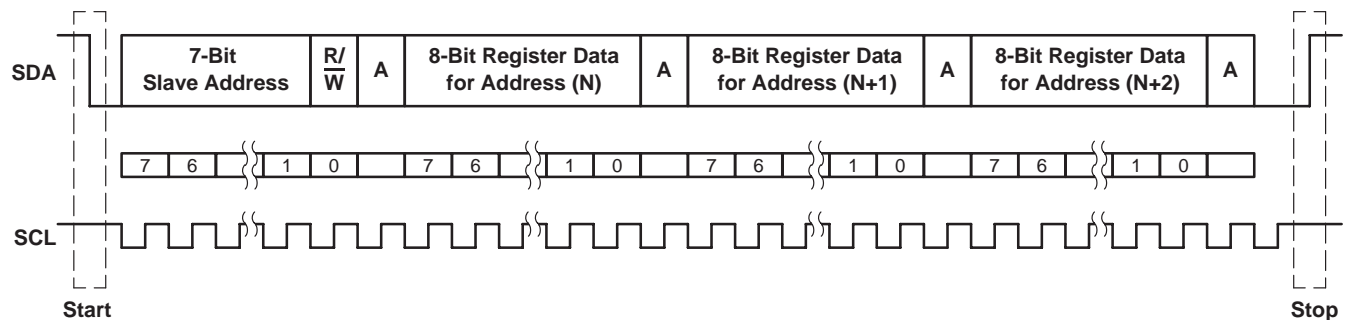

Figure 6–1. Typical I²C Data Transfer Sequence

Table 6–1 lists the definitions used by the I²C protocol.

Table 6–1. I²C Protocol Definitions

DEFINITION	DESCRIPTION
Transmitter	The device that sends data
Receiver	The device that receives data
Master	The device that initiates a transfer, generates clock signals, and terminates the transfer
Slave	The device addressed by the master
Multimaster	More than one master can attempt to control the bus at the same time without corrupting the message.
Arbitration	Procedure to ensure the message is not corrupted when two masters attempt to control the bus.
Synchronization	Procedure to synchronize the clock signals of two or more devices

6.3 Operation

The 7-bit address for the TAS3002 device is 0110 10X R \overline{W} where X is a programmable address bit, set by terminal 7 (CS1). Combining CS1 and the R \overline{W} bit, the TAS3002 device can respond to four different I²C addresses (two read and two write). These two addresses are licensed I²C addresses that do not conflict with other licensed I²C audio devices. In addition to the 7-bit device address, subaddresses direct communication to the proper memory location within the device. A complete table of subaddresses and control registers is provided in Appendix A. For example, to change bass to 10-dB gain, Section 6.3.1 shows the data that is written to the I²C port:

Table 6–2. I²C Address Byte Table

I ² C ADDRESS BYTE	A6–A1	CS1 (A0)	R \overline{W}
68h	011010	0	0
69h	011010	0	1
6Ah	011010	1	0
6Bh	011010	1	1

6.3.1 Write Cycle Example

Start	Slave Address	R \overline{W}	A	Subaddress	A	Data	A	Stop
-------	---------------	------------------	---	------------	---	------	---	------

FUNCTION	DESCRIPTION
Start	Start condition as defined in I ² C
Slave address	0110100 (CS1 = 0)
R \overline{W}	0 (write)
A	Acknowledgement as defined in I ² C (slave)
Subaddress (treble control register)	0000 0101
Data (0 dB gain)	0111 0010
Stop	Stop condition as defined in I ² C

NOTE: Table is for serial data (SDA); serial clock (SCL) is not shown but conditions apply as well.

Whenever writing to a subaddress, the correct number of data bytes must follow in order to complete the write cycle. For example, if the volume control register with subaddress 04h is written to, six bytes of data must follow; otherwise, the cycle is incomplete and errors occur.

6.3.2 TAS3002 I²C Readback Example

The TAS3002 saves in a stack or first-in first-out (FIFO) buffer the last 7 bytes that were sent to it. When an I²C read command is sent to the device (LSB=high), it answers by popping the first byte off the stack. The TAS3002 then expects either a Send Ack command or an I²C Stop command from the host. If a Send Ack command is sent from the host then the TAS3002 pops another byte off the stack. If an I²C Stop is sent then the TAS3002 ends this transaction. The proper sequence for reading is described as follows:

I ² C Start
Send I ² C address byte with read bit set to 1 (LSB set equal to 1)
Receive Byte 0
Send Ack
Receive Byte 1
Send Ack
Receive Byte 2
Send Ack
Receive Byte 3
Send Ack
Receive Byte 4
Send Ack
Receive Byte 5
Send Ack
Receive Byte 6 (if an ACK is sent after byte 6 it locks up the TAS3002)
I ² C Stop

Where:

- I²C Start is a valid I²C Start command.
- Receive Byte is a valid I²C command which reads a byte from the TAS3002.
- Send Ack is a a valid I²C command that informs the TAS3002 that a byte has been read.
- I²C Stop is a valid I²C Stop command.

NOTES: 1. The TAS3002 will appear to be locked up, if a Send Ack is issued after the last byte read. It is required to send an I²C Stop command after the last byte and not a Send Ack.
2. The I²C Start and I²C Stop commands are the same for both I²C read and I²C write.

6.3.3 I²C Wait States

The TAS3002 device performs interpolation algorithms for its volume and tone controls. If a volume or tone change is sent to the part via I²C, the command sent after the volume or tone (bass and treble) change causes an I²C wait state to occur. This wait state lasts from 41 ms to 231 ms, depending on the system clock rate, the command sent, and, in the case of bass or treble, the amount of the change.

Secondly, if a long series of commands is sent to the TAS3002 device, it may occasionally create a short wait state on the order of 150 μ s to 300 μ s while it loads and processes the commands.

When a sample rate of 32 kHz is used, longer wait states can occur, occasionally up to 15 ms.

The preferred way to take care of wait states is to use an I²C controller that recognizes wait states. During the wait state period, it stops sending data over I²C. If this function is not available on the system controller, fixed delays can be implemented in the system software to ensure that the controller is not trying to send more data while the TAS3002 device is busy. Sending I²C data while the TAS3002 device is busy causes errors and locks up the device, which must then be reset.

Table 6–3 gives typical values of the wait states that can be expected with the various functions of the part:

Table 6–3. I²C Wait States

	SYSTEM SAMPLING FREQUENCY			Comment
	32 kHz	44.1 kHz	48 kHz	
Volume	62 ms	49 ms	41 ms	Not dependent on size of change
Bass	231 ms	167 ms	153 ms	0 to –18 dB
Treble	231 ms	167 ms	153 ms	0 to –18 dB
DRC on	300 μ s	300 μ s	300 μ s	
Mixer	None	None	None	
Loudness	None	None	None	
Equalization	15 ms	190 μ s	300 μ s	Can occur with each filter

6.4 SMBus Operation

The TAS3002 device supports a subset of the SMBus protocol. With proper programming techniques, it is possible to use the SMBus to set up the TAS3002 device.

6.4.1 Block Write Protocol

The TAS3002 device supports the block write protocol that allows up to 32 bytes to be sent as a block. To send a command using this format, the most significant bit (MSB) of the TAS3002 subaddress must be set high and the subaddress (also with MSB set high) must be programmed into the SMBus command byte. This operation signals the TAS3002 device that the next byte is the SMBus byte-count byte. The next byte after the byte count is then entered into the device as the first byte of data.

SMBus Command Byte					
68h	8rh	xx	dd	dd	dd
TAS3002 Address	Subaddress (r = subaddress)	Byte Count (Don't Care)	Data	Data	Data

6.4.2 Write Byte Protocol

The TAS3002 device also supports the SMBus write byte protocol. Writing to the main control register (MCR), bass, and treble registers requires using the byte write protocol. To send a command using this protocol, the most significant bit (MSB) of the TAS3002 subaddress must be set high and the subaddress (also with MSB set high) must be programmed into the SMBus command byte. The next byte after the command byte is then entered into the device as the first byte of data.

SMBus Command Byte		
68h	8rh	dd
TAS3002 Address	Subaddress (r = subaddress)	Data

6.4.3 Wait States

If separate I²C/SMBus commands are sent too frequently, the TAS3002 device can generate a bus wait state. This happens when the device is busy while performing smoothing operations and changing volume, bass, and treble. The wait occurs after the bus acknowledge on the first data byte and can exceed the maximum allowable time allowed according to the SMBus specification (worst case 200 ms).

The following is a possible bus wait state scenario:

CODE	Start	68	84	06	01	00	00	01	00	00	Stop	
ACTUAL	Start	68	84	06	01	Wait [†]	00	00	01	00	00	Stop

[†] If the master does not recognize bus waiting or if the master times out on a long wait, the master must not send consecutive I²C/SMBus commands without a time interval of 200 ms between transactions.

6.4.4 TAS3002 SMBus Readback

The TAS3002 device supports a subset of SMBus readback. When an SMBus read command is sent to the device (LSB = high), it answers with the subaddress and the last six bytes written.

		SMBus Command Byte	Byte Count							
SENT	Start	69h	xxh	07h	Stop					
RECEIVED	Start	07h	aah	ddh	ddh	ddh	ddh	ddh	ddh	Stop

Byte
Count

Where:

- xxh = Command byte. It is a *don't care* because the response contains only the subaddress and the last six bytes of data written to the TAS3002 device.
- aah = The last subaddress accessed in the device
- ddh = Data bytes from the TAS3002 device

NOTE: Use read sequence defined in 6.3.2

7 Microcontroller Operation

The TAS3002 device contains an internal microcontroller programmed by Texas Instruments to perform housekeeping and interface functions. Additionally, it handles I²C communication and general purpose input functions.

7.1 General Description

The microcontroller uses a 256f_S system clock and can access up to 8K bytes of memory. It interfaces with the digital audio interface I²C master/slave for downloading data and coefficients. It also interfaces with two internal DSPs for transferring coefficients and other information.

The TAS3002 coefficients are loaded through I²C in the master or slave mode. Standard audio processing functions (volume, bass, and treble) can be controlled/activated through external switches connected to the six GPI terminals. Upon reset, the internal microcontroller sets all coefficients and audio parameters to the default values. See Section 7.2.2 for default values.

If the TAS3002 address is 68h (ADDR_SEL=0), it becomes the bus master device and attempts to load parameters and coefficients from the external EEPROM. If no EEPROM is present, the TAS3002 device remains in its default condition. If addresses other than 68h/69h are set, the TAS3002 device only operates as an I²C slave device.

If the microcontroller determines the TAS3002 device has an I²C address of 68h/69h and the EEPROM is present, the microcontroller downloads coefficients from the EEPROM. Once the download is complete, it enables the serial audio in the mode defined by an I²C write to the MCR to transfer data into and out of the device. Before reading the EEPROM, the serial audio port defaults to I²S mode.

The TAS3002 device allows the user to update volume, bass, and treble dynamically by an I²C slave command or by a simple GPI input. The GPI can select volume up and down, bass/treble up and down, or digital equalizations. Up to five different equalizations (that is, flat, jazz, rock, voice, etc.) can be stored in the external EEPROM. Also, DRCE, MCR1, MCR2, and loudness contour are enabled and disabled by I²C.

When the TAS3002 device operates in the I²C master mode, it echoes changes to all of its functions to other I²C addresses that are defined in its external EEPROM. If no addresses are defined, it does not echo.

7.2 Power-Up/Power-Down Reset

7.2.1 Power-Up Sequence

An active low on terminal 6 ($\overline{\text{RESET}}$) while MCLK is running resets the internal microcontroller and DSPs. $\overline{\text{RESET}}$ synchronizes internally and can be asserted asynchronously or with the simple RC circuit in Figure 7–1. On reset, SCL and SDA go to a high-impedance state. If the I²C address is set to 68h, approximately 400 μs after $\overline{\text{RESET}}$ returns to a 1, the device sends a one-byte query via I²C to look for an EEPROM. If an EEPROM is found, the TAS3002 becomes an I²C master; otherwise, it becomes an I²C slave. When using address 68h in the slave mode, an external master must wait until after the EEPROM query or else bus contention and improper operation occur.

I²C address x6Ah does not query the bus for an EEPROM. The address for the EEPROM is A0h.

7.2.2 Reset

The TAS3002 device has an asynchronous reset terminal ($\overline{\text{RESET}}$). This reset is synchronized with various clocks used in this device to generate a synchronous internal reset. Upon reset, the TAS3002 device goes through the following process:

- Clears all the RAM memory content

- Clears all the registers in the circuits
- Purges the codec
- Selects analog input A (RINA and LINA) and sets the input A active indicator ($\overline{\text{INPA}}$) low
- Initializes the equalization parameters to AllPass filters
- Sets the digital audio interface to the I²S 18-bit mode
- Sets the bass/treble to 0 dB
- Sets the mixer gain to 0 dB SDIN1 and mutes both SDIN2 and analog-in
- Sets the volume to -40 dB
- Turns off all enhancement features (DRCE, etc.)
- Reads the I²C address. If the address is 68h, the device reads its EEPROM. It is possible to load the user-defined bass/treble data and break points (optional). If there is no data, the device loads default bass/treble delta and break points from ROM.
- If the address is 6Ah, the device puts the I²C interface in slave mode and waits for input.

7.2.3 Reset Circuit

Because the TAS3002 device has an internal power-on reset (POR), in many cases, additional components are not needed to reset the device. It resets internally at approximately 80% of V_{DD} .

In the case where the system power supplies are slow in reaching their final voltage or where there is a difference in the time the system power supplies take to become stable, the TAS3002 reset can be delayed by a simple RC circuit.

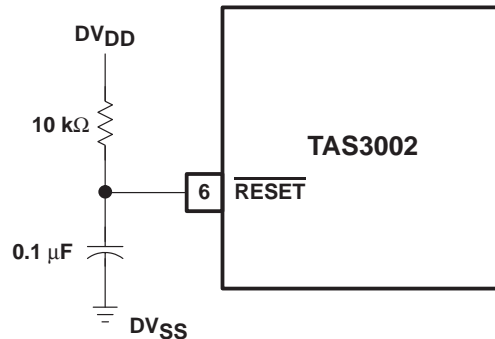

Figure 7-1. TAS3002 Reset Circuit

The reset delay for the above circuit can be calculated by the simple equation:

$$t_{rd} = 0.8RC + 400 \mu s$$

Where: t_{rd} = The delay before the TAS3002 device comes out of reset

C = Value of the capacitance from $\overline{\text{RESET}}$ (pin 6) to DV_{SS}

R = Value of the resistance from $\overline{\text{RESET}}$ (pin 6) to DV_{DD}

The circuit described in Figure 7-1 delays the start-up of the TAS3002 device approximately 1.2 ms.

When it is necessary to control the reset of the TAS3002 device with an external device, such as a microcontroller, $\overline{\text{RESET}}$ (pin 6) can be treated as a logic signal. It then brings the device out of reset when the voltage on $\overline{\text{RESET}}$ reaches $V_{DD}/2$.

7.2.4 Fast Load Mode

While in fast load mode—FL bit (bit 7 of main control register 1) = 0—it is possible to update the parametric equalization without any audio processing delay. The audio processor pauses while the RAM is updated in this mode.

Bass and treble cannot download in this mode. Mixer1 and Mixer2 registers can download in this mode or normal mode (FL bit = 0).

Once the download is complete, the fast load bit must be cleared by writing a 0 into bit 7 of main control register 1 (MCR1). This puts the TAS3002 device into normal mode.

7.2.5 Codec Reset

During initialization, the output of the codec is disabled. Throughout reset and initialization, the output of the DAC is muted to prevent extraneous noise being sent to the system output.

Data from the ADC and other internal processing is purged so that when reset/initialization is complete, only valid inputs are sent to the system output.

7.3 Power-Down Mode

The TAS3002 device has an asynchronous power-down mode. In the power-down mode, the internal control registers and equalization programming of the device are stored in the device.

To enter power-down mode:

1. Assert the power-down control signal (1)
2. Set the serial audio input clocks to 0

The TAS3002 device goes into power-down mode.

To exit the power-down mode:

1. Assert $\overline{\text{RESET}}$ (logic 0)
2. Restart the serial audio clocks
3. Wait for a delay of 1.0 ms (to allow the PLL to lock)
4. Negate the power-down control signal (logic 0)
5. Negate $\overline{\text{RESET}}$ (logic 1)

The device then returns to the state it was in before power down (resumes normal operation).

7.3.1 Power-Down Timing Sequence

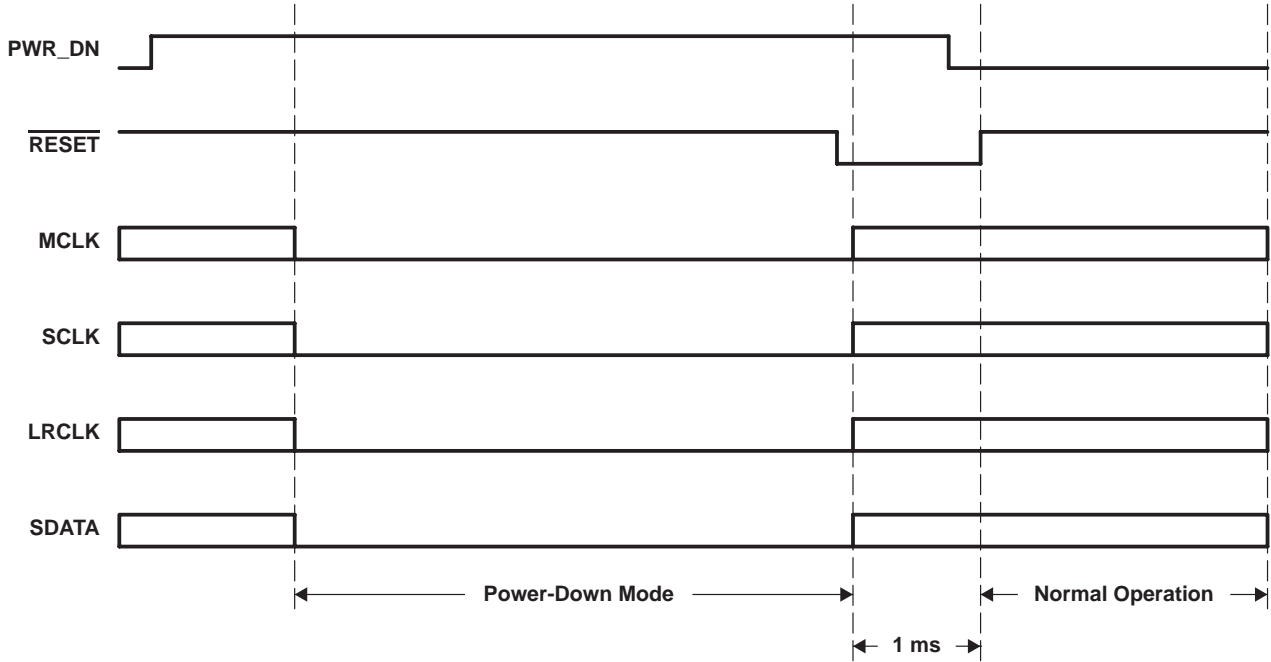

Figure 7–2. Power-Down Timing Sequence

In power-down mode, the TAS3002 device typically consumes less than 1 mA.

7.4 Test Mode

Terminal 9 (TEST) is tied low in normal operation. This function is reserved for factory test and must not be asserted.

7.5 Internal Interface

Figure 7–3 shows the flow chart of the interface between the microcontroller and its peripheral blocks.

7.6 GPI Terminal Programming

During initialization, the microcontroller fetches a control byte from its EEPROM or receives a command from I²C.

7.6.1 GPI Interface

The six GPI terminals are programmed to operate as indicated in Table 7–1.

Table 7–1. GPI Terminal Programming

	GPI5	GPI4	GPI3	GPI2	GPI1	GPI0
VOL_UP, +1 dB	x					
VOL_DN, –1 dB		x				
BASS_UP, +1 dB			x			
BASS_DN, –1 dB				x		
TREB_UP, +1 dB					x	
TREB_DN, –1 dB						x
Shift 1	x					x
Mute	x					
EQ1		x				
EQ2			x			
EQ3				x		
EQ4					x	
EQ5						x
Shift 2			x	x		

NOTE: x = Logic low

Initially (after reset), the TAS3002 GPI is set to control volume, bass, and treble. Simultaneously setting GPI bits 1 and 5 low for 1 second changes the function of the GPI terminals to control mute and equalization.

To return to volume, bass, and treble control, simultaneously set GPI terminals 2 and 3 low for 1 second.

When a GPI terminal is activated, the TAS3002 device echoes its function over I²C to a TAS3001 device mapped to address 6Ah. Therefore, a system with two audio equalization chips can be implemented without the need for a microcontroller.

7.6.2 GPI Architecture

The GPI provides simple but flexible input port to activate the input parameters. Each terminal input is an active logic low.

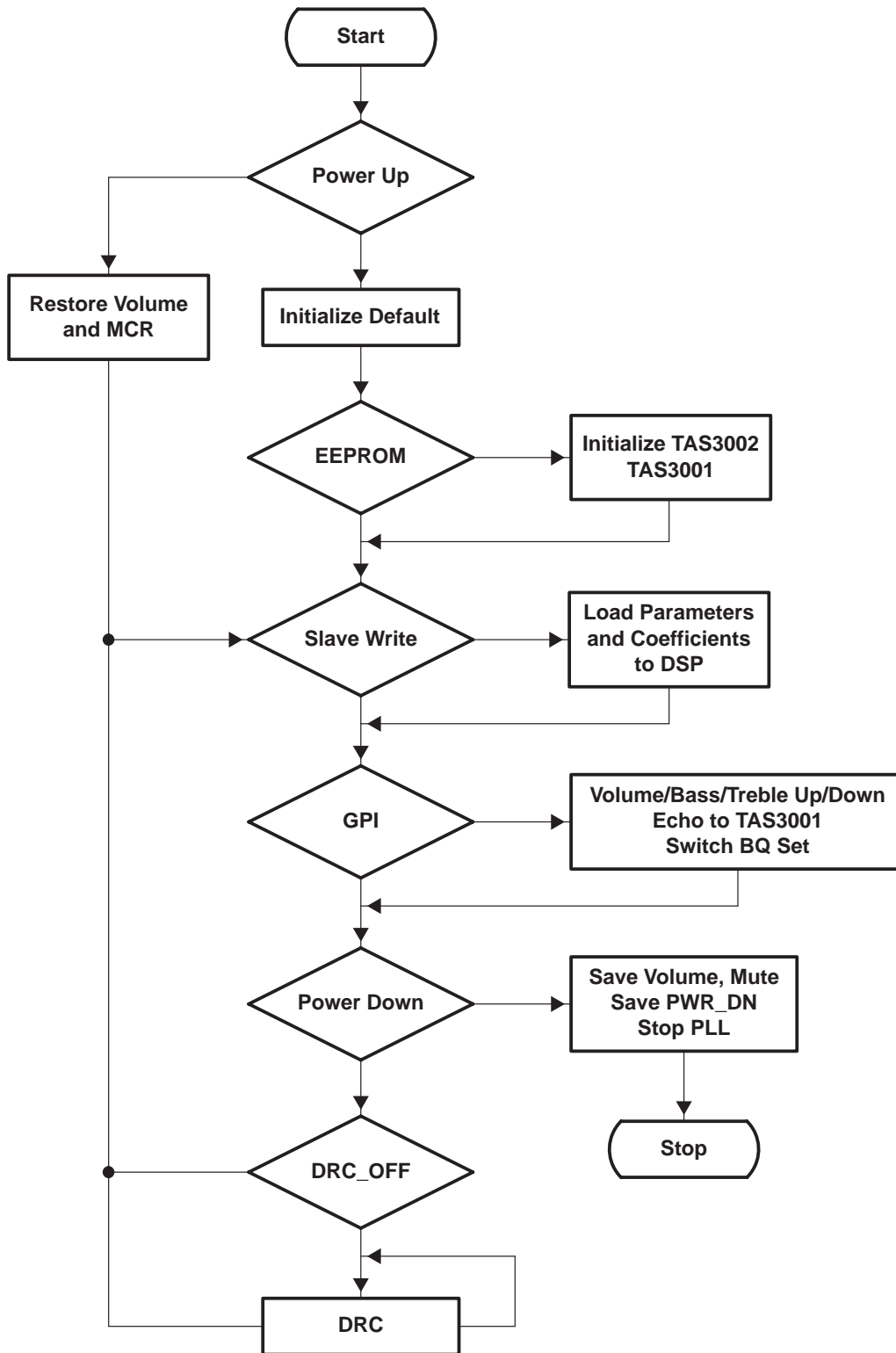

Figure 7-3. Internal Interface Flow Chart

7.7 External EEPROM Memory Maps

Table 7–2 through Table 7–5 show the 512-byte and 2048-byte EEPROM memory maps.

Table 7–2. 512-Byte EEPROM Memory Map 2.0 Channels

ADDRESS	BYTE NUMBER	FUNCTION	
000h	1	Signature (2Ah)	
001h	1	ID byte = 0000 0000	
002h	1	MCR	
003h–00Bh	9	Mixer left gain	
00Ch–014h	9	Mixer right gain	
015h–01Ah	2	DRC (ratio, threshold, energy α , attack α , decay α)	
01Bh	1	Bass	
01Ch	1	Treble	
01Dh–022h	6	Volume	
031h–03Fh	15	Biquad 0	Left channel
040h–04Eh	15	Biquad 1	
04Fh–05Dh	15	Biquad 2	
05Eh–06Ch	15	Biquad 3	
06Dh–07Bh	15	Biquad 4	
07Ch–08Ah	15	Biquad 5	
08Bh–099h	15	Biquad 6	
09Ah	1	0 dB/bass	
09Bh	1	0 dB/treble	
09Ch–0A1h	6	Bass break	
0A2h–0A7h	6	Treble break	
0A8h–110h	105	Bass delta	
111h–179h	105	Treble delta	
17Ah–17Fh	6	Bass set point	
180h–185h	6	Treble set point	
186h–194h	15	Biquad 0	Right channel
195h–1A3h	15	Biquad 1	
1A4h–1B2h	15	Biquad 2	
1B3h–1C1h	15	Biquad 3	
1C2h–1D0h	15	Biquad 4	
1D1h–1DFh	15	Biquad 5	
1E0h–1EEh	15	Biquad 6	

NOTE: Bytes are in the same order as they appear in the I²C register map. The EEPROM address is A0h.

Table 7–3. 512-Byte EEPROM Memory Map 2.1 Channels (with TAS3001)

ADDRESS	BYTE NUMBER	FUNCTION	
000h	1	Signature (2Ah)	
001h	1	ID byte = 0000 0011	
TAS3002			
002h	1	MCR	
003h–00Bh	9	Mixer left gain	
00Ch–014h	9	Mixer right gain	
015h–01Ah	6	DRC (ratio, threshold, energy α , attack α , decay α)	
01Bh	1	Bass	
01Ch	1	Treble	
01Dh–022h	6	Volume	
031h–03Fh	15	Biquad 0	TAS3002 right and left channel
040h–04Eh	15	Biquad 1	
04Fh–05Dh	15	Biquad 2	
05Eh–06Ch	15	Biquad 3	
06Dh–07Bh	15	Biquad 4	
07Ch–08Ah	15	Biquad 5	
08Bh–099h	15	Biquad 6	
09Ah	1	0 dB/bass	
09Bh	1	0 dB/treble	
09Ch–0A1h	6	Bass break	
0A2h–0A7h	6	Treble break	
0A8h–110h	105	Bass delta	
111h–179h	105	Treble delta	
17Ah–17Fh	6	Bass set point	
180h–185h	6	Treble set point	
186h–194h	15	Biquad 0	TAS3001 right and left channel
195h–1A3h	15	Biquad 1	
1A4h–1B2h	15	Biquad 2	
1B3h–1C1h	15	Biquad 3	
1C2h–1D0h	15	Biquad 4	
1D1h–1DFh	15	Biquad 5	
1E0h–1EEh	15	Biquad 6	
TAS3001			
1EFh	1	MCR	
1F0h–1F2h	3	SDIN1 gain	
1F3h–1F5h	3	SDIN2 gain	
1F6h–1F7h	2	DRC (ratio, threshold, energy α , attack α , decay α)	
1F8h	1	Bass	
1F9h	1	Treble	
1FAh–1FFh	6	Volume	

NOTE: In this mode, the TAS3002 and the TAS3001 devices both use the same equalization coefficients for their right and left channels. Bytes are in the same order as they appear in the I²C register map. The EEPROM address is A0h.

Table 7-4. 2048-Byte EEPROM Memory Map—2.0 Speakers With Multiple Equalizations

TAS3002 ADDRESS LEFT BIQUAD	NUMBER OF BYTES	FUNCTION	CATEGORY	TAS3002 ADDRESS RIGHT BIQUAD	TAS3001	
000h	1	Signature (2Ah)				
001h	1	1	0	0	0	
002h	1	MCR			1EFh	
003h–00Bh	9/3	Mixer left gain			1F0h–1F2h	
00Ch–014h	9/3	Mixer right gain			1F3h–1F5h	
015h–019h	6/2	DRC (ratio, threshold, energy α , attack α , decay α)			1F6h–1F7h	
01Ah	1	Bass			1F8h	
01Bh	1	Treble			1F9h	
01Ch–021h	6	Volume			1FAh–1FFh	
031h–03Fh	15	Biquad 0	Set 0	3A4h–3B2h	186h–194h	
040h–04Eh	15	Biquad 1		3B3h–3C1h	195h–1A3h	
04Fh–05Dh	15	Biquad 2		3C2h–3D0h	1A4h–1B2h	
05Eh–06Ch	15	Biquad 3		3D1h–3DFh	1B3h–1C1h	
06Dh–07Bh	15	Biquad 4		3E0h–3EEh	1C2h–1D0h	
07Ch–08Ah	15	Biquad 5		3EFh–3FDh	1D1h–1DFh	
08Bh–099h	15	Biquad 6		3FEh–40Ch	1E0h–1EEh	
09Ah–185h	236	Bass treble table				
200h–20Eh	15	Biquad 0	Set 1	40Dh–41Bh	5B1h–5BFh	
20Fh–21Dh	15	Biquad 1		41Ch–42Ah	5C0h–5CEh	
21Eh–22Ch	15	Biquad 2		42Bh–439h	5CFh–5DDh	
22Dh–23Bh	15	Biquad 3		43Ah–448h	5DEh–5ECh	
23Ch–24Ah	15	Biquad 4		449h–457h	5EDh–5FBh	
24Bh–259h	15	Biquad 5		458h–466h	5FCh–60Ah	
25Ah–268h	15	Biquad 6		467h–475h	60Bh–619h	
269h–277h	15	Biquad 0	Set 2	476h–484h	61Ah–628h	
278h–286h	15	Biquad 1		485h–493h	629h–637h	
287h–295h	15	Biquad 2		494h–4A2h	638h–646h	
296h–2A4h	15	Biquad 3		4A3h–4B1h	647h–655h	
2A5h–2B3h	15	Biquad 4		4B2h–4C0h	656h–664h	
2B4h–2C2h	15	Biquad 5		4C1h–4CFh	665h–673h	
2C3h–2D1h	15	Biquad 6		4D0h–4DEh	674h–682h	
2D2h–2E0h	15	Biquad 0	Set 3	4DFh–4EDh	683h–691h	
2E1h–2EFh	15	Biquad 1		4EEh–4FCh	692h–6A0h	
2F0h–2FEh	15	Biquad 2		4FDh–50Bh	6A1h–6AFh	
2FFh–30Dh	15	Biquad 3		50Ch–51Ah	6B0h–6BEh	
30Eh–31Ch	15	Biquad 4		51Bh–529h	6BFh–6CDh	
31Dh–32Bh	15	Biquad 5		52Ah–538h	6CEh–6DCh	
32Ch–33Ah	15	Biquad 6		539h–547h	6DDh–6EBh	
33Bh–349h	15	Biquad 0	Set 4	548h–556h	6ECh–6FAh	
34Ah–358h	15	Biquad 1		557h–565h	6FBh–709h	
359h–367h	15	Biquad 2		566h–574h	70Ah–718h	
368h–376h	15	Biquad 3		575h–583h	719h–727h	
377h–385h	15	Biquad 4		584h–592h	728h–736h	
386h–394h	15	Biquad 5		593h–5A1h	737h–745h	
395h–3A3h	15	Biquad 6		5A2h–5B0h	746h–754h	

NOTE: Bytes are in the same order as they appear in the I²C register map. The EEPROM address is A0h.

Table 7–5. 2048-Byte EEPROM Memory Map—2.1 Speakers With Multiple Equalizations

TAS3002 ADDRESS	NUMBER OF BYTES	FUNCTION				CATEGORY		TAS3001 ADDRESS LEFT CHANNEL	TAS3001 ADDRESS RIGHT CHANNEL	
000h	1	Signature (2Ah)								
001h	1	1	0	0	0	0	0	1		
002h	1	MCR						1EFh		
003h–00Bh	9/3	Mixer left gain						1F0h–1F2h		
00Ch–014h	9/3	Mixer right gain						1F3h–1F5h		
015h–019h	6/2	DRC (ratio, threshold, energy α , attack α , decay α)						1F6h–1F7h		
01Ah	1	Bass						1F8h		
01Bh	1	Treble						1F9h		
01Ch–021h	6	Volume						1FAh–1FFh		
031h–03Fh	15	Biquad 0				Set 0	186h–194h		3A4h–3B2h	
040h–04Eh	15	Biquad 1					195h–1A3h		3B3h–3C1h	
04Fh–05Dh	15	Biquad 2					1A4h–1B2h		3C2h–3D0h	
05Eh–06Ch	15	Biquad 3					1B3h–1C1h		3D1h–3DFh	
06Dh–07Bh	15	Biquad 4					1C2h–1D0h		3E0h–3EEh	
07Ch–08Ah	15	Biquad 5					1D1h–1DFh		3EFh–3FDh	
08Bh–099h	15	Biquad 6					1E0h–1EEh		3FEh–40Ch	
09Ah–185h	236	Bass treble table								
200h–20Eh	15	Biquad 0				Set 1	5B1h–5BFh		40Dh–41Bh	
20Fh–21Dh	15	Biquad 1					5C0h–5CEh		41Ch–42Ah	
21Eh–22Ch	15	Biquad 2					5CFh–5DDh		42Bh–439h	
22Dh–23Bh	15	Biquad 3					5DEh–5ECh		43Ah–448h	
23Ch–24Ah	15	Biquad 4					5EDh–5FBh		449h–457h	
24Bh–259h	15	Biquad 5					5FCh–60Ah		458h–466h	
25Ah–268h	15	Biquad 6				60Bh–619h		467h–475h		
269h–277h	15	Biquad 0				Set 2	61Ah–628h		476h–484h	
278h–286h	15	Biquad 1					629h–637h		485h–493h	
287h–295h	15	Biquad 2					638h–646h		494h–4A2h	
296h–2A4h	15	Biquad 3					647h–655h		4A3h–4B1h	
2A5h–2B3h	15	Biquad 4					656h–664h		4B2h–4C0h	
2B4h–2C2h	15	Biquad 5					665h–673h		4C1h–4CFh	
2C3h–2D1h	15	Biquad 6				674h–682h		4D0h–4DEh		
2D2h–2E0h	15	Biquad 0				Set 3	683h–691h		4DFh–4EDh	
2E1h–2EFh	15	Biquad 1					692h–6A0h		4EEh–4FCh	
2F0h–2FEh	15	Biquad 2					6A1h–6AFh		4FDh–50Bh	
2FFh–30Dh	15	Biquad 3					6B0h–6BEh		50Ch–51Ah	
30Eh–31Ch	15	Biquad 4					6BFh–6CDh		51Bh–529h	
31Dh–32Bh	15	Biquad 5					6CEh–6DCh		52Ah–538h	
32Ch–33Ah	15	Biquad 6				6DDh–6EBh		539h–547h		
33Bh–349h	15	Biquad 0				Set 4	6ECh–6FAh		548h–556h	
34Ah–358h	15	Biquad 1					6FBh–709h		557h–565h	
359h–367h	15	Biquad 2					70Ah–718h		566h–574h	
368h–376h	15	Biquad 3					719h–727h		575h–583h	
377h–385h	15	Biquad 4					728h–736h		584h–592h	
386h–394h	15	Biquad 5					737h–745h		593h–5A1h	
395h–3A3h	15	Biquad 6				746h–754h		5A2h–5B0h		

NOTE: Bytes are in the same order as they appear in the I²C register map. The EEPROM address is A0h.

8 Electrical Characteristics

8.1 Absolute Maximum Ratings Over Operating Temperature Ranges†

Supply voltage range: AV_{DD}	-0.3 V to 3.6 V
DV_{DD}	-0.3 V to 3.6 V
Analog input voltage range:	-0.3 to $AV_{DD} + 0.3$ V
Digital input voltage range:	-0.3 to $DV_{DD} + 0.3$ V
Operating free-air temperature, T_A	0°C to 70°C
Storage temperature range, T_{stg}	-65°C to 150°C
Case temperature for 10 seconds	+122°C
Lead temperature from case for 10 seconds	+97.8°C
Electrostatic discharge (see Note 1)	2000 V

† Stresses beyond those listed under absolute maximum ratings may cause permanent damage to the device. These are stress ratings only, and functional operation of the device at these or any other conditions beyond those indicated under recommended operating conditions is not implied. Exposure to absolute-maximum-rated conditions for extended periods may affect device reliability.

NOTE 1: Human body model per Method 3015.2 of MIL-STD-883B.

8.2 Recommended Operating Conditions

$T_A = 25^\circ\text{C}$, $AV_{DD} = 3.3$ V, $DV_{DD} = 3.3$ V

Voltages at analog inputs and outputs and at AV_{DD} are with respect to ground.

		MIN	NOM	MAX	UNIT
Supply voltage, AV_{DD}		3.0	3.3	3.6	V
Supply voltage, DV_{DD}		3.0	3.3	3.6	V
Supply current, analog	Operating	34			mA
	Power down (see Note 2)	88			μA
Supply current, digital	Operating	47			mA
	Power down (see Note 2)	942			μA
Power dissipation	Operating	267			mW
	Power down (see Note 2)	3.5			mW

NOTE 2: If the clocks are turned off.

8.3 Static Digital Specifications

$T_A = 25^\circ\text{C}$, $AV_{DD} = 3.3$ V, $DV_{DD} = 3.3$ V

PARAMETER		TEST CONDITIONS	MIN	MAX	UNIT
V_{IH}	High-level input voltage		2.0	3.6	V
V_{IL}	Low-level input voltage		-0.3	0.8	V
V_{OH}	High-level output voltage	$I_O = -1$ mA	2.4		V
V_{OL}	Low-level output voltage	$I_O = +4$ mA		0.4	V
Input leakage current			-10	10	μA
Output load capacitance				50	pF

8.4 ADC Digital Filter

$T_A = 25^\circ\text{C}$, $AV_{DD} = 3.3\text{ V}$, $DV_{DD} = 3.3\text{ V}$, $f_S = 48\text{ kHz}$, 20-bit I²S mode

All terms characterized by frequency are scaled with the chosen sampling frequency, f_S . See Figure 8–1 through Figure 8–4 for performance curves of the ADC digital filter.

PARAMETER		TEST CONDITIONS	MIN	TYP	MAX	UNIT
ADC decimation filter (LPF)	Pass band		0.0		20.0	kHz
	Pass band ripple			± 0.01		dB
	Stop band			24.1		kHz
	Stop band attenuation		80			dB
	Group delay			720		μs
ADC high-pass filter (HPF)	Pass band (-3 dB)			0.87		Hz
	Deviation from linear phase	20 Hz to 20 kHz		1.23		degrees

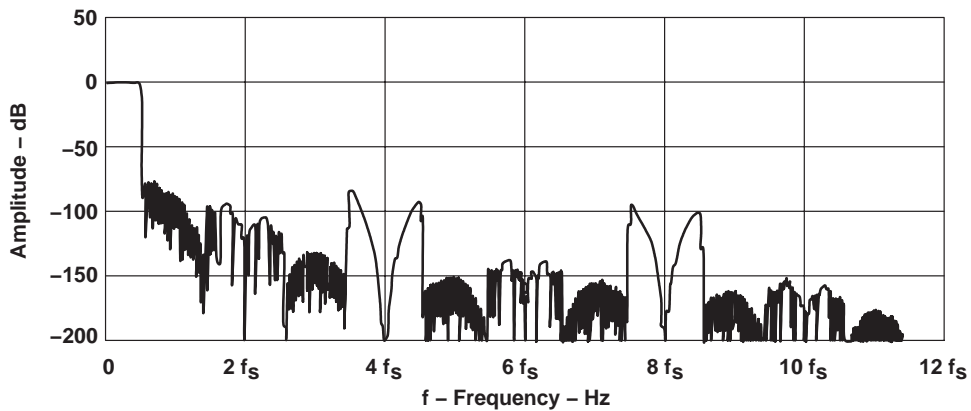

Figure 8–1. ADC Digital Filter Characteristics

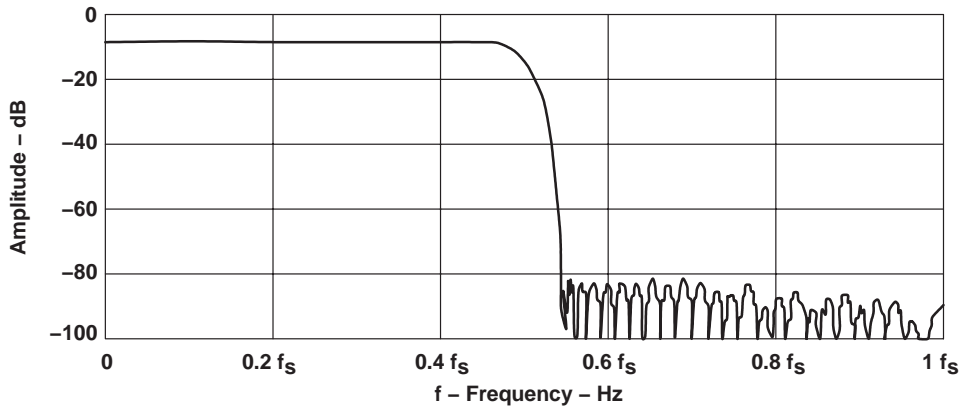

Figure 8–2. ADC Digital Filter Stop-Band Characteristics

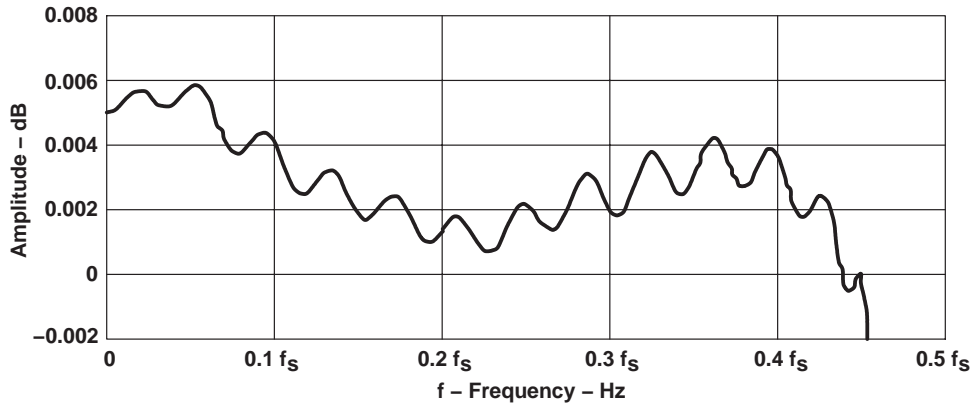

Figure 8-3. ADC Digital Filter Pass-Band Characteristics

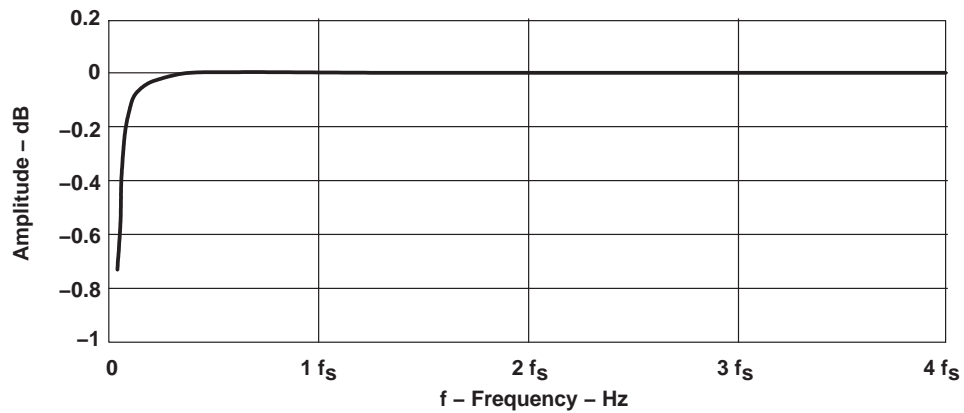

Figure 8-4. ADC High-Pass Filter Characteristics

8.5 Analog-to-Digital Converter

$T_A = 25^\circ\text{C}$, $AV_{DD} = 3.3\text{ V}$, $DV_{DD} = 3.3\text{ V}$, $f_S = 48\text{ kHz}$, 20-bit I²S mode

All terms characterized by frequency are scaled with the chosen sampling frequency, f_S .

PARAMETER	TEST CONDITIONS	MIN	TYP	MAX	UNIT
SNR (EIAJ)	A weighted		93		dB
Dynamic range	-60 dB, 1 kHz		88		dB
Signal to (noise + distortion) ratio	-1 dB, 1 kHz, 20 Hz to 20 kHz		82		dB
Power supply rejection ratio	1 kHz (see Note 3)		50		dB
Idle channel tone rejection			+110		dB
Intermodulation distortion			-80		dB
ADC crosstalk			-93		dB
Overall ADC frequency response	20 Hz to 20 kHz		± 0.1		dB
Gain error				5%	
Gain matching			± 0.02		dB

NOTE 3: Measured with a 50-mV peak sine curve.

8.6 Input Multiplexer

$T_A = 25^\circ\text{C}$, $AV_{DD} = 3.3\text{ V}$, $DV_{DD} = 3.3\text{ V}$, $f_S = 48\text{ kHz}$, 20-bit I²S mode

PARAMETER	TEST CONDITIONS	MIN	TYP	MAX	UNIT
Input impedance			20		k Ω
Crosstalk			85		dB
Full-scale input voltage range			1.7		V _{PP}

8.7 DAC Interpolation Filter

$T_A = 25^\circ\text{C}$, $AV_{DD} = 3.3\text{ V}$, $DV_{DD} = 3.3\text{ V}$, $f_S = 48\text{ kHz}$, 20-bit I²S mode

All terms characterized by frequency are scaled with the normal mode sampling frequency, f_S . See Figure 8–5 and Figure 8–6 for performance curves of the DAC digital filter.

PARAMETER	TEST CONDITIONS	MIN	TYP	MAX	UNIT
Pass band		0.0		20.0	kHz
Pass-band ripple			± 0.005		dB
Stop band			24.1		kHz
Stop-band attenuation	28.8 kHz to 3 MHz	75			dB
Group delay			700		μs

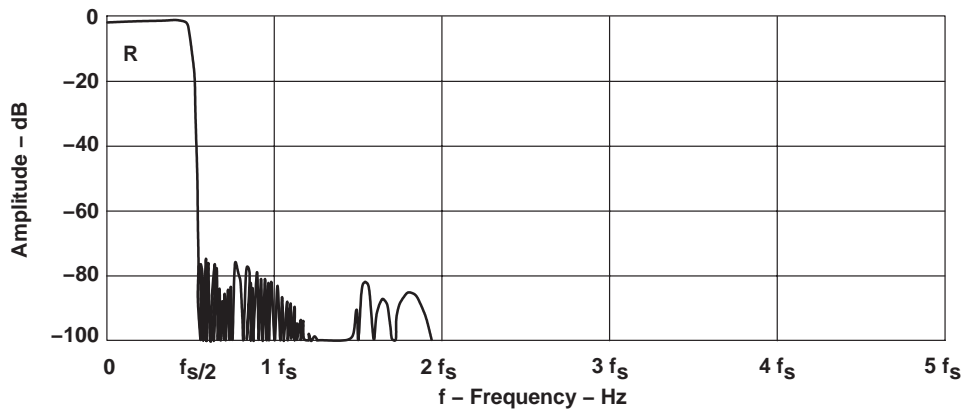

Figure 8–5. DAC Filter Overall Frequency Characteristics

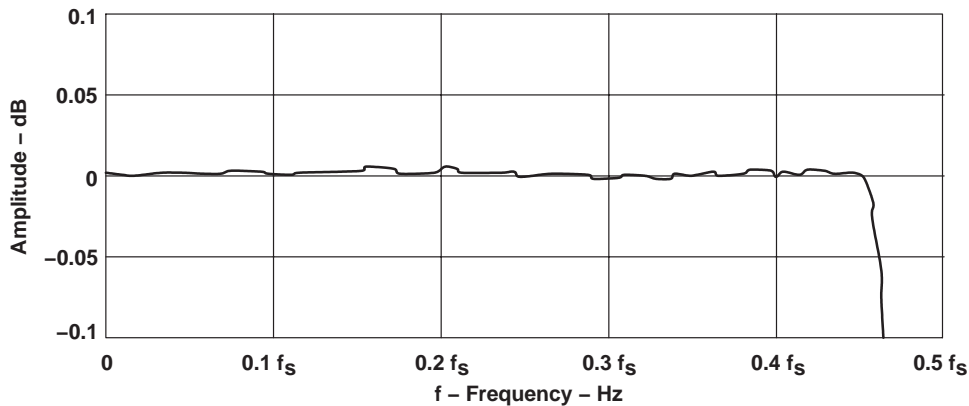

Figure 8–6. DAC Digital Filter Pass-Band Ripple Characteristics

8.8 Digital-to-Analog Converter

$T_A = 25^\circ\text{C}$, $AV_{DD} = 3.3\text{ V}$, $DV_{DD} = 3.3\text{ V}$, $f_S = 48\text{ kHz}$, input = 0 dB- f_S sine wave at 1 kHz

PARAMETER	TEST CONDITIONS	MIN	TYP	MAX	UNIT
SNR (EIAJ)	A weighted	94	99		dB
Dynamic range	-60 dB, 1 kHz	92	96		dB
Signal to (noise + distortion) ratio	0 dB, 1 kHz, 20 Hz to 20 kHz		83		dB
Power supply rejection ratio	1 kHz		50		dB
Idle channel tone rejection			+118		dB
Intermodulation distortion			-75		dB
Frequency response		-0.5		+0.5	dB
Deviation from linear phase				± 1.4	degree
DAC crosstalk			-96		dB
Jitter tolerance			150		ps
Full scale, single-ended, output voltage range			1.9		V_{PP}
DC offset		-7.0		7.0	mV

8.9 DAC Output Performance Data

$T_A = 25^\circ\text{C}$, $AV_{DD} = 3.3\text{ V}$, $DV_{DD} = 3.3\text{ V}$

The output load resistance is connected through a dc blocking capacitor.

PARAMETER	TEST CONDITIONS	MIN	TYP	MAX	UNIT
Output load resistance		10			$k\Omega$
Output load capacitance				25	pF
VCOM internal resistance (see Note 4)			1		$k\Omega$
VCOM output CLOAD			10	100	μF
VRFILF internal resistance (see Note 5)			1		$k\Omega$

NOTES: 4. VCOM may vary during power down.

5. VRFILF must never be used as a voltage reference.

8.10 I²C Serial Port Timing Characteristics

	MIN	MAX	UNIT
$f_{(SCL)}$ SCL clock frequency	0	100	kHz
$t_{(buf)}$ Bus free time between start and stop	4.7		μ s
$t_{(low)}$ Low period of SCL clock	4.7		μ s
$t_{(high)}$ High period of SCL clock	4.0		μ s
$t_{h(sta)}$ Hold time repeated start	4.0		μ s
$t_{su(sta)}$ Setup time repeated start	4.7	20	μ s
$t_{h(dat)}$ Data hold time (See Note 6)	0		μ s
$t_{su(dat)}$ Data setup time	250		ns
t_r Rise time for SDA and SCL		1000	ns
t_f Fall time for SDA and SCL		300	ns
$t_{su(sto)}$ Setup time for stop condition	4.0		μ s
$C_{(b)}$ Capacitive load for each bus line		400	pF

NOTE 6: A device must internally provide a hold time of at least 300 ns for the SDA signal to bridge the undefined region of the falling edge of SCL.

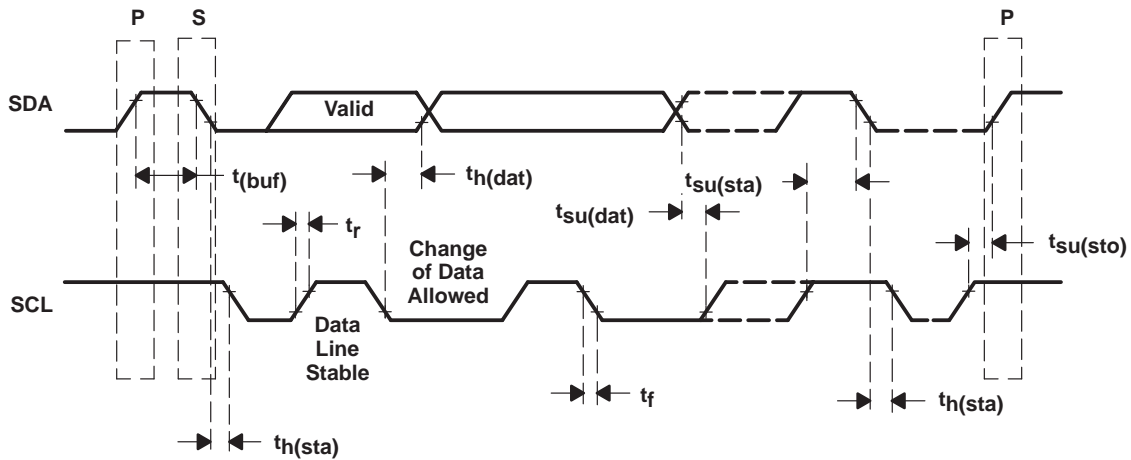

NOTE: $t_{(low)}$ is measured from the end of t_f to the beginning of t_r .
 $t_{(high)}$ is measured from the end of t_r to the beginning of t_f .

Figure 8-7. I²C Bus Timing

9 System Diagrams

Figure 9–1 and Figure 9–2 show the TAS3002 stereo and 2.1-channel applications, respectively.

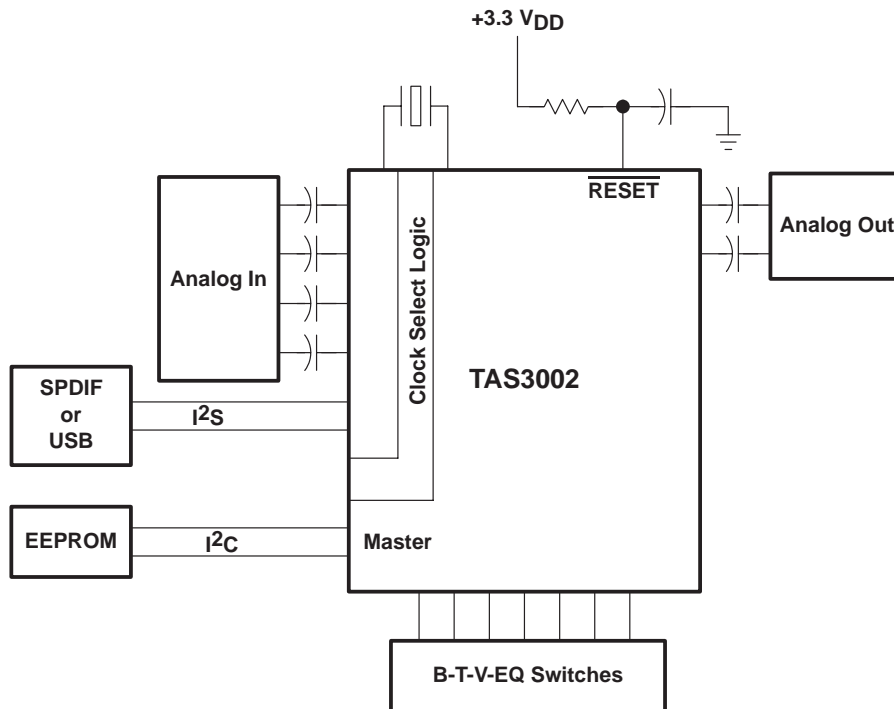

NOTE: Items such as the PLL network and power supplies are omitted for clarity.

Figure 9–1. Stereo Application

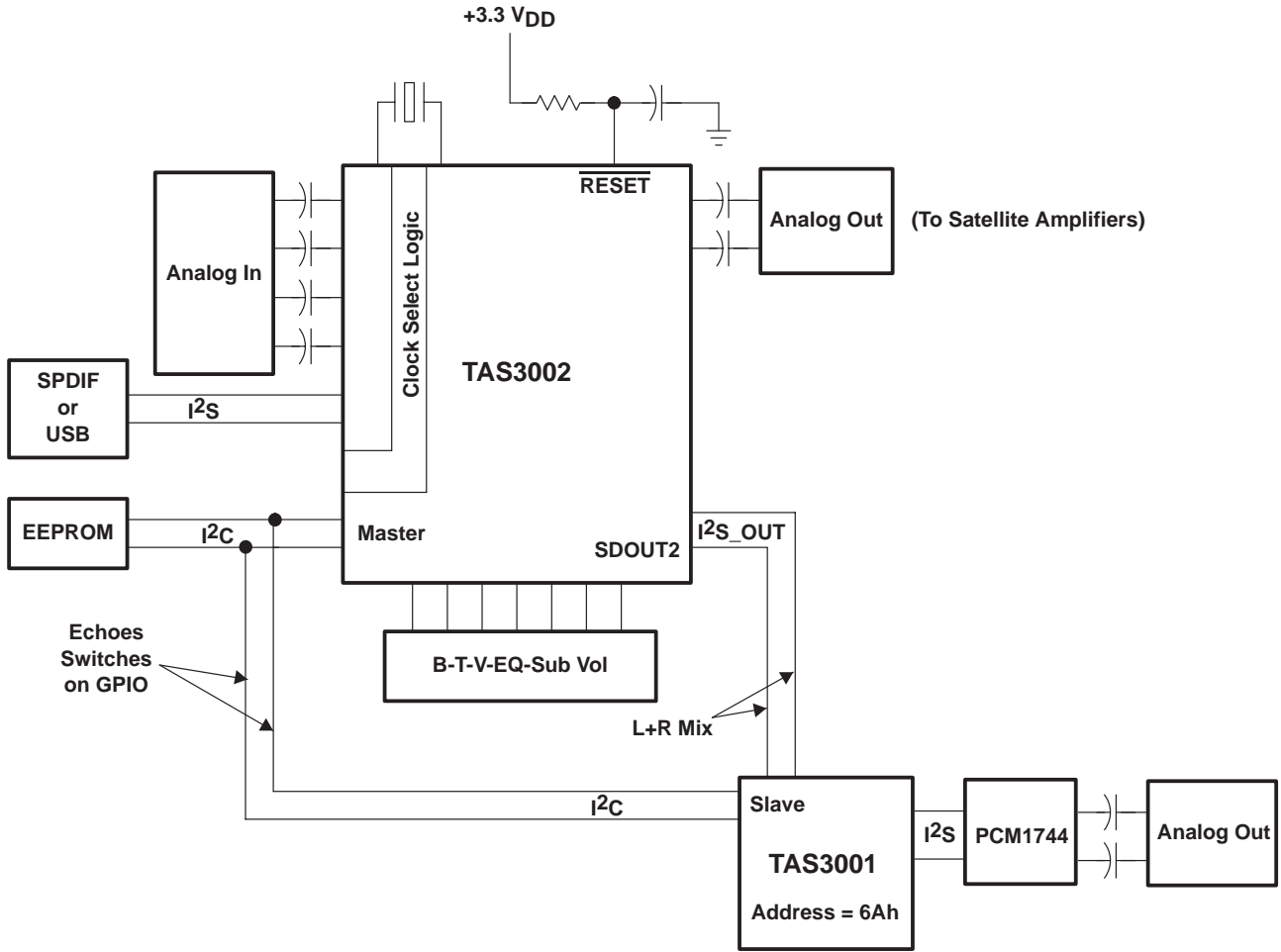

NOTE: Items such as the PLL network and power supplies are omitted for clarity.

Figure 9–2. TAS3002 Device, 2.1 Channels

10 Mechanical Information

The TAS3002 device is packaged in a 48-terminal PFB package. The following illustration shows the mechanical dimensions for the PFB package.

PFB (S-PQFP-G48)

PLASTIC QUAD FLATPACK

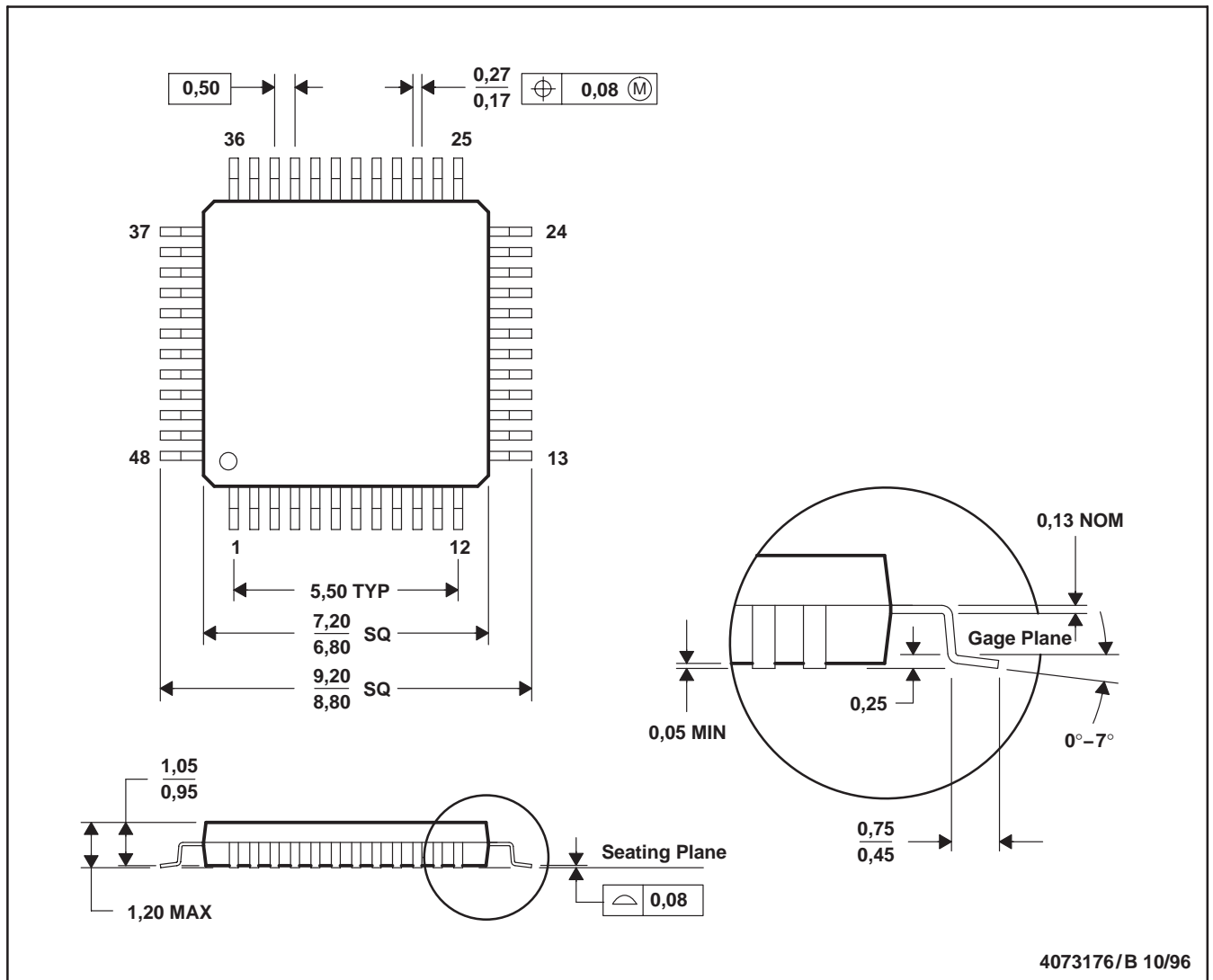

- NOTES:
- A. All linear dimensions are in millimeters.
 - B. This drawing is subject to change without notice.
 - C. Falls within JEDEC MS-026

PACKAGING INFORMATION

Orderable Device	Status ⁽¹⁾	Package Type	Package Drawing	Pins	Package Qty	Eco Plan ⁽²⁾	Lead/ Ball Finish	MSL Peak Temp ⁽³⁾	Samples (Requires Login)
TAS3002PFB	ACTIVE	TQFP	PFB	48	1	Green (RoHS & no Sb/Br)	CU NIPDAU	Level-2-260C-1 YEAR	
TAS3002PFBG4	ACTIVE	TQFP	PFB	48	1	Green (RoHS & no Sb/Br)	CU NIPDAU	Level-2-260C-1 YEAR	
TAS3002PFBR	ACTIVE	TQFP	PFB	48	1000	Green (RoHS & no Sb/Br)	CU NIPDAU	Level-2-260C-1 YEAR	
TAS3002PFBRG4	ACTIVE	TQFP	PFB	48	1000	Green (RoHS & no Sb/Br)	CU NIPDAU	Level-2-260C-1 YEAR	

⁽¹⁾ The marketing status values are defined as follows:

ACTIVE: Product device recommended for new designs.

LIFEBUY: TI has announced that the device will be discontinued, and a lifetime-buy period is in effect.

NRND: Not recommended for new designs. Device is in production to support existing customers, but TI does not recommend using this part in a new design.

PREVIEW: Device has been announced but is not in production. Samples may or may not be available.

OBSELETE: TI has discontinued the production of the device.

⁽²⁾ Eco Plan - The planned eco-friendly classification: Pb-Free (RoHS), Pb-Free (RoHS Exempt), or Green (RoHS & no Sb/Br) - please check <http://www.ti.com/productcontent> for the latest availability information and additional product content details.

TBD: The Pb-Free/Green conversion plan has not been defined.

Pb-Free (RoHS): TI's terms "Lead-Free" or "Pb-Free" mean semiconductor products that are compatible with the current RoHS requirements for all 6 substances, including the requirement that lead not exceed 0.1% by weight in homogeneous materials. Where designed to be soldered at high temperatures, TI Pb-Free products are suitable for use in specified lead-free processes.

Pb-Free (RoHS Exempt): This component has a RoHS exemption for either 1) lead-based flip-chip solder bumps used between the die and package, or 2) lead-based die adhesive used between the die and leadframe. The component is otherwise considered Pb-Free (RoHS compatible) as defined above.

Green (RoHS & no Sb/Br): TI defines "Green" to mean Pb-Free (RoHS compatible), and free of Bromine (Br) and Antimony (Sb) based flame retardants (Br or Sb do not exceed 0.1% by weight in homogeneous material)

⁽³⁾ MSL, Peak Temp. -- The Moisture Sensitivity Level rating according to the JEDEC industry standard classifications, and peak solder temperature.

Important Information and Disclaimer: The information provided on this page represents TI's knowledge and belief as of the date that it is provided. TI bases its knowledge and belief on information provided by third parties, and makes no representation or warranty as to the accuracy of such information. Efforts are underway to better integrate information from third parties. TI has taken and continues to take reasonable steps to provide representative and accurate information but may not have conducted destructive testing or chemical analysis on incoming materials and chemicals. TI and TI suppliers consider certain information to be proprietary, and thus CAS numbers and other limited information may not be available for release.

In no event shall TI's liability arising out of such information exceed the total purchase price of the TI part(s) at issue in this document sold by TI to Customer on an annual basis.

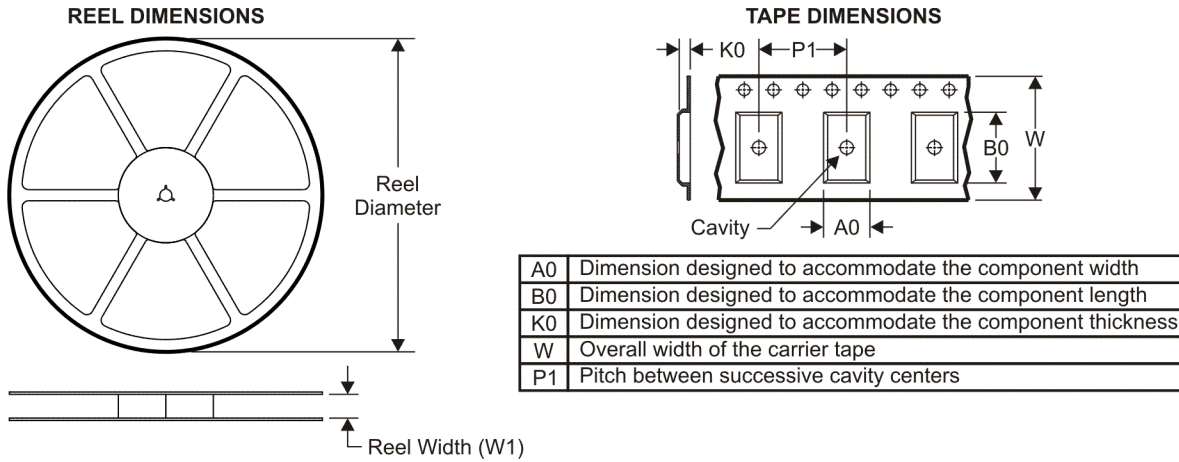
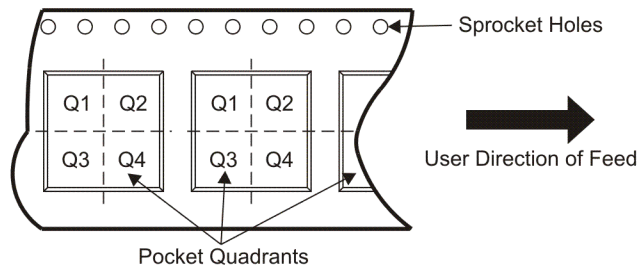
TAPE AND REEL INFORMATION

QUADRANT ASSIGNMENTS FOR PIN 1 ORIENTATION IN TAPE

*All dimensions are nominal

Device	Package Type	Package Drawing	Pins	SPQ	Reel Diameter (mm)	Reel Width W1 (mm)	A0 (mm)	B0 (mm)	K0 (mm)	P1 (mm)	W (mm)	Pin1 Quadrant
TAS3002PFBR	TQFP	PFB	48	1000	330.0	16.4	9.6	9.6	1.5	12.0	16.0	Q2

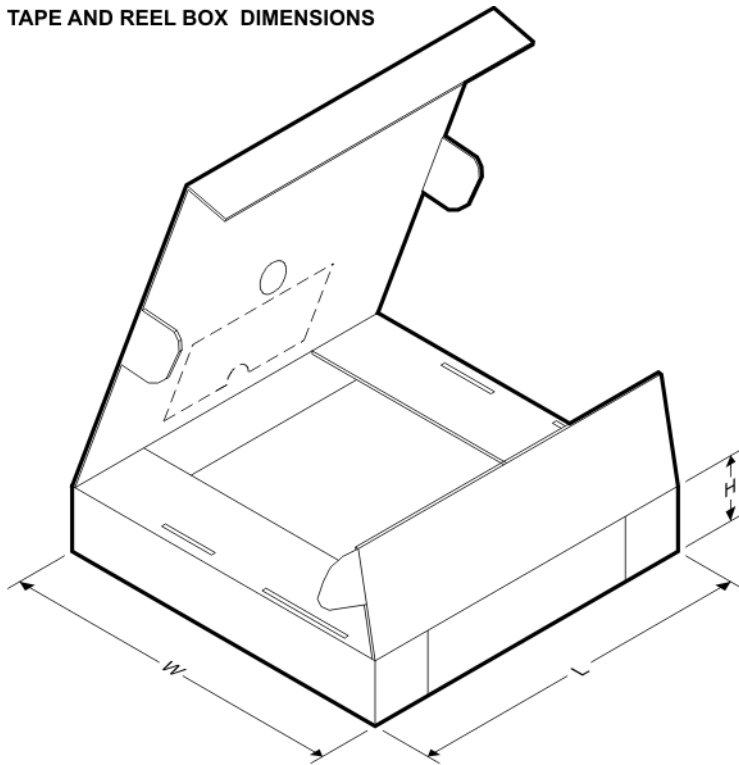
TAPE AND REEL BOX DIMENSIONS



*All dimensions are nominal

Device	Package Type	Package Drawing	Pins	SPQ	Length (mm)	Width (mm)	Height (mm)
TAS3002PFBR	TQFP	PFB	48	1000	346.0	346.0	33.0

IMPORTANT NOTICE

Texas Instruments Incorporated and its subsidiaries (TI) reserve the right to make corrections, modifications, enhancements, improvements, and other changes to its products and services at any time and to discontinue any product or service without notice. Customers should obtain the latest relevant information before placing orders and should verify that such information is current and complete. All products are sold subject to TI's terms and conditions of sale supplied at the time of order acknowledgment.

TI warrants performance of its hardware products to the specifications applicable at the time of sale in accordance with TI's standard warranty. Testing and other quality control techniques are used to the extent TI deems necessary to support this warranty. Except where mandated by government requirements, testing of all parameters of each product is not necessarily performed.

TI assumes no liability for applications assistance or customer product design. Customers are responsible for their products and applications using TI components. To minimize the risks associated with customer products and applications, customers should provide adequate design and operating safeguards.

TI does not warrant or represent that any license, either express or implied, is granted under any TI patent right, copyright, mask work right, or other TI intellectual property right relating to any combination, machine, or process in which TI products or services are used. Information published by TI regarding third-party products or services does not constitute a license from TI to use such products or services or a warranty or endorsement thereof. Use of such information may require a license from a third party under the patents or other intellectual property of the third party, or a license from TI under the patents or other intellectual property of TI.

Reproduction of TI information in TI data books or data sheets is permissible only if reproduction is without alteration and is accompanied by all associated warranties, conditions, limitations, and notices. Reproduction of this information with alteration is an unfair and deceptive business practice. TI is not responsible or liable for such altered documentation. Information of third parties may be subject to additional restrictions.

Resale of TI products or services with statements different from or beyond the parameters stated by TI for that product or service voids all express and any implied warranties for the associated TI product or service and is an unfair and deceptive business practice. TI is not responsible or liable for any such statements.

TI products are not authorized for use in safety-critical applications (such as life support) where a failure of the TI product would reasonably be expected to cause severe personal injury or death, unless officers of the parties have executed an agreement specifically governing such use. Buyers represent that they have all necessary expertise in the safety and regulatory ramifications of their applications, and acknowledge and agree that they are solely responsible for all legal, regulatory and safety-related requirements concerning their products and any use of TI products in such safety-critical applications, notwithstanding any applications-related information or support that may be provided by TI. Further, Buyers must fully indemnify TI and its representatives against any damages arising out of the use of TI products in such safety-critical applications.

TI products are neither designed nor intended for use in military/aerospace applications or environments unless the TI products are specifically designated by TI as military-grade or "enhanced plastic." Only products designated by TI as military-grade meet military specifications. Buyers acknowledge and agree that any such use of TI products which TI has not designated as military-grade is solely at the Buyer's risk, and that they are solely responsible for compliance with all legal and regulatory requirements in connection with such use.

TI products are neither designed nor intended for use in automotive applications or environments unless the specific TI products are designated by TI as compliant with ISO/TS 16949 requirements. Buyers acknowledge and agree that, if they use any non-designated products in automotive applications, TI will not be responsible for any failure to meet such requirements.

Following are URLs where you can obtain information on other Texas Instruments products and application solutions:

Products

Audio	www.ti.com/audio
Amplifiers	amplifier.ti.com
Data Converters	dataconverter.ti.com
DLP® Products	www.dlp.com
DSP	dsp.ti.com
Clocks and Timers	www.ti.com/clocks
Interface	interface.ti.com
Logic	logic.ti.com
Power Mgmt	power.ti.com
Microcontrollers	microcontroller.ti.com
RFID	www.ti-rfid.com
OMAP Mobile Processors	www.ti.com/omap
Wireless Connectivity	www.ti.com/wirelessconnectivity

Applications

Automotive and Transportation	www.ti.com/automotive
Communications and Telecom	www.ti.com/communications
Computers and Peripherals	www.ti.com/computers
Consumer Electronics	www.ti.com/consumer-apps
Energy and Lighting	www.ti.com/energy
Industrial	www.ti.com/industrial
Medical	www.ti.com/medical
Security	www.ti.com/security
Space, Avionics and Defense	www.ti.com/space-avionics-defense
Video and Imaging	www.ti.com/video

TI E2E Community Home Page

e2e.ti.com

Mailing Address: Texas Instruments, Post Office Box 655303, Dallas, Texas 75265
Copyright © 2012, Texas Instruments Incorporated

Looking for pricing, stock, or lifecycle information?

Click below to explore more details on WIN SOURCE:

 [View DA-REF105](#) on WIN SOURCE

 [Texas Instruments](#) Information

Optimize Your Supply Chain with WIN SOURCE Solutions

-  Global Sourcing Solution
-  Obsolete Management
-  Cost Control Management
-  Shortage Management
-  Alternative Solution
-  Excess Inventory Management