

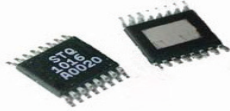

**THE DATASHEET OF
STQ-1016**





RFMD Green, RoHS Compliant, Pb-Free (Z Part Number)
 Package: TSSOP, 16-Pin, 5.0mmx6.4mmx1.0mm

Product Description

RFMD's STQ-1016Z is a direct quadrature modulator targeted for use in a wide range of communications systems, including cellular/PCS, GSM, CDMA, TETRA, and ISM datacom. This device features a wide 250MHz to 1000MHz operating frequency band, excellent carrier and sideband suppression, and a low broadband noise floor.

The STQ-1016 uses silicon germanium (SiGe) device technology and delivers a typical output power of -9dBm with greater than 60dB IM3 suppression. A digital input shut-down feature is included that, when enabled, attenuates the output by 60dB. The device is packaged in an industry standard 16-pin TSSOP with exposed paddle for superb RF and thermal ground.

The matte tin finish on Sirenza's lead-free package utilizes a post annealing process to mitigate tin whisker formation and is RoHS compliant per EU directive 2002/95. This package is also manufactured with green molding compounds that contain no antimony trioxide nor halogenated fire retardants.

Optimum Technology Matching® Applied

- GaAs HBT
- GaAs MESFET
- InGaP HBT
- SiGe BiCMOS
- Si BiCMOS
- SiGe HBT
- GaAs pHEMT
- Si CMOS
- Si BJT
- GaN HEMT
- RF MEMS

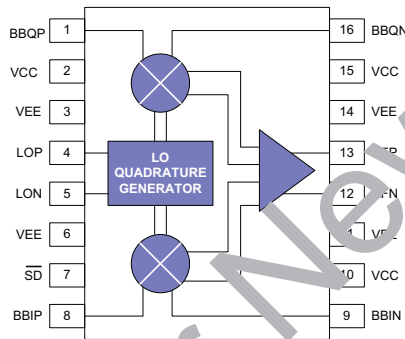

Features

- Available in Lead Free, RoHS Compliant, and Green Packaging
- Excellent Carrier Feedthrough, -38dBm Constant Over Output Power
- Output P1dB +5dBm
- Very Low Noise Floor, -154dBm/Hz Typical
- Wide Baseband Input, DC to 500MHz
- Superb Phase Accuracy and Amplitude Balance, $\pm 0.5^\circ\text{C}/\pm 0.2\text{dB}$
- Low LO Drive Requirement, -5dBm

Applications

- Cellular/PCS/GSM/CDMA Transceivers
- TETRA
- GMSK, QPSK, QAM, SSB Mod.

Parameter	Specification			Unit	Condition
	Min.	Typ.	Max.		
RF Output: TA = 25 °C					
RF Frequency Range	50		1000	MHz	
Output Power	-12	-9	-7	dBm	(Baseband input level 600mV _{p,p} differential)
RF Port Return Loss		>10, 250 to 1000MHz >15, 275 to 500MHz		dB	Matched to 50Ω using schematic shown on page 5
Output P1dB	+3	+6		dBm	(Baseband input level 3.8V _{p,p} differential typical)
Carrier Feedthrough		-38	-30	dBm	
Sideband Suppression	34	42		dB	
IM3 Suppression	58	62		dB	2-tone BB input @ 600mV _{p,p} diff. per tone, 20kHz spacing
Broadband Noise Floor		-154	-150*	dBm/Hz	Baseband inputs tied to 1.9V _{DC} , -20MHz offset from carrier
Quadrature Phase Error	-2.0	±0.5	+2.0	°C	
I/Q Amplitude Balance	-0.20	±0.05	+0.20	dB	
Supply Voltage	+4.75	+5.00	+5.25	V	
Supply Current		80	86	mA	
Device Thermal Resistance		25		°C/W	Junction to case

Test Conditions: V_{CE} = 2.7V, I_Q = 11 mA Typ. (unless otherwise noted), T_L = 25 °C. OIP3 Tone Spacing = 1 MHz, P_{OUT} per tone = -5 dBm.
 [1] Data with Application Circuit.

Absolute Maximum Ratings

Parameter	Rating	Unit
Supply Voltage (V_{CC})	6.0	V_{DC}
LO, RF Input (LOP, LON, RFP, RFN)	+10	dBm
Baseband Min Input Voltage (BBIP, BBIN, BBQP, BBQN)	0	V_{DC}
Baseband Max Input Voltage (BBIP, BBIN, BBQP, BBQN)	3	V_{DC}
Operating Temperature	-40 to +85	$^{\circ}C$
Storage Temperature	-65 to +150	$^{\circ}C$



Caution! ESD sensitive device.

Exceeding any one or a combination of the Absolute Maximum Rating conditions may cause permanent damage to the device. Extended application of Absolute Maximum Rating conditions to the device may reduce device reliability. Specified typical performance or functional operation of the device under Absolute Maximum Rating conditions is not implied.

RoHS status based on EU Directive 2002/95/EC (at time of this document revision).

The information in this publication is believed to be accurate and reliable. However, no responsibility is assumed by RF Micro Devices, Inc. ("RFMD") for its use, nor for any infringement of patents, or other rights of third parties, resulting from its use. No license is granted by implication or otherwise under any patent or patent rights of RFMD. RFMD reserves the right to change component circuitry, recommended application circuitry and specifications at any time without prior notice.

*Note: Load condition1, $Z_L = 50\Omega$. Load condition2, $Z_L = 10:1$ VSWR.

Operation of this device beyond any one of these limits may cause permanent damage. For reliable continuous operation, the device voltage and current must not exceed the maximum operating values specified in the table on page one.

Bias Conditions should also satisfy the following expression:

$$I_D V_D < (T_J - T_L) / R_{TH, j-l} \text{ and } T_L = T_{LEAD}$$

Parameter	Specification			Unit	Condition
	Min.	Typ.	Max.		
Baseband Modulation Input: $T_A = 25^{\circ}C$					
Baseband Frequency Input	DC		500	MHz	-5dB bandwidth, baseband inputs terminated in 50Ω
Baseband Input Resistance		4.4		k Ω	Per pin
Baseband Input Capacitance		0.5		fF	Per pin
LO Input: $T_A = 25^{\circ}C$					
LO Frequency	250		1000	MHz	
LO Drive Level	-8	-5		dBm	
LO Port Return Loss		>10, 250 to 1000 >15, 275 to 1000		MHz	Matched to 50Ω using schematic shown on page 5
Miscellaneous: $T_A = 25^{\circ}C$					
Shut-Down Supply Current		45	60	mA	Shut-down enabled
Shut-Down Attenuation		0		dB	
Shut-Down Pin Resistance		1.5		k Ω	@ 1MHz
Shut-Down Pin Capacitance		12		pF	@ 1MHz
Shut-Down Control Voltage Thresholds	0.75		V_{CC}	V	Shut-Down disabled (normal operation)
	0.0		1.5	V	Shut-Down enabled
Shut-Down Settling Time		<450		ns	

Test Conditions (for all product specification tables unless otherwise noted): V_{CC} (pins 2, 10, 15) = +5V, $T_A = +25^{\circ}C$,

Baseband Input (Pins 1, 8, 9, 16) = 1.2V_{rms} bias, 200kHz frequency, 300mV_{p,p} per pin = 600mV_{p,p} differential drive, I and Q signals in quadrature, LO Input (Pins 4, 5) = -5dBm @ 250 to 1000MHz

250MHz to 1000MHz Typical Device Performance

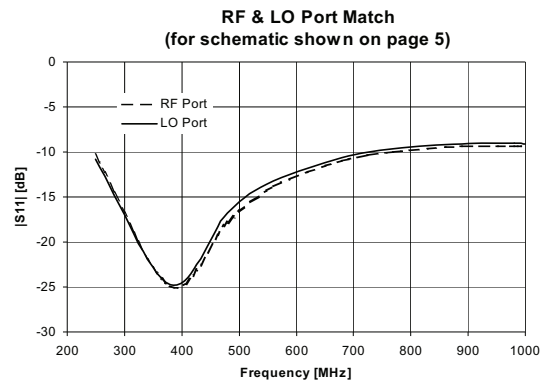
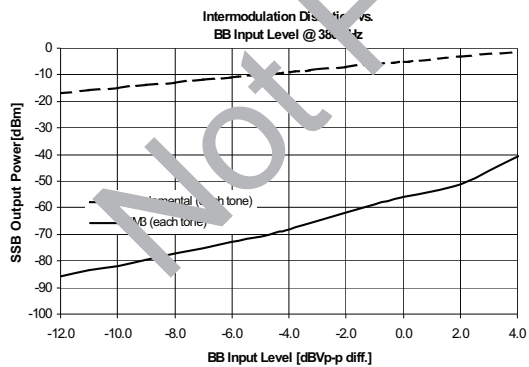
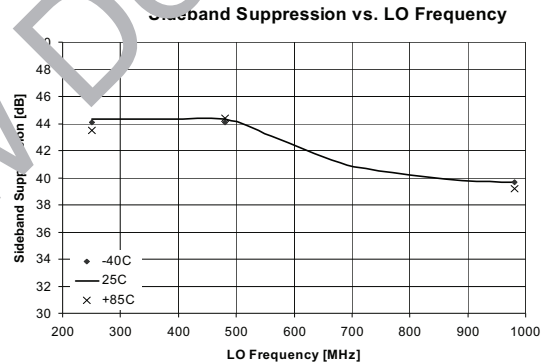
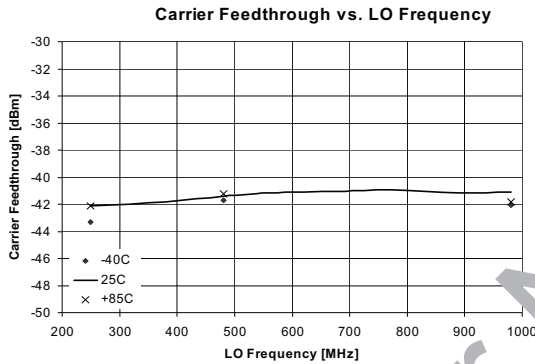
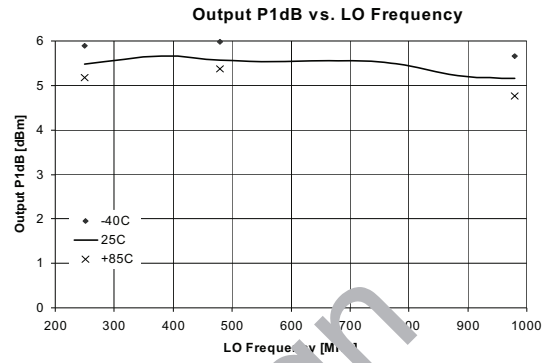
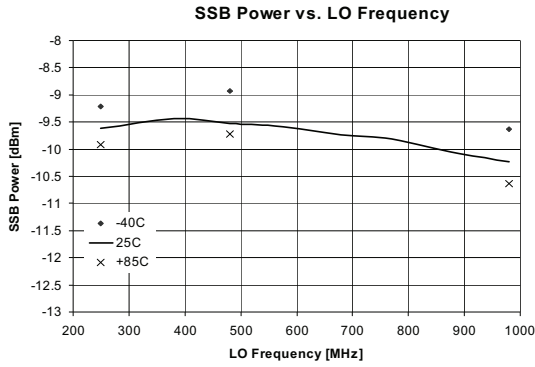

Pin	Function	Description
1	BBQP	Q-channel baseband input, positive terminal. Nominal DC bias voltage is 1.9V (biased internally).
2	VCC	Positive supply (+5V).
3	VEE	Ground.
4	LOP	Local oscillator input, positive terminal. Nominal DC voltage is 2.0V. Input should be AC-coupled.
5	LON	Local oscillator input, negative terminal. Nominal DC voltage is 2.0. Input should be AC-coupled.
6	VEE	Ground.
7	SD	Shut-down control. Logic high=normal operation; logic low=shut-down enabled.
8	BBIP	I-channel baseband input, positive terminal. Nominal DC bias voltage is 1.9V (biased internally).
9	BBIN	I-channel baseband input, negative terminal. Nominal DC bias voltage is 1.9V (biased internally).
10	VCC	Positive supply (+5V).
11	VEE	Ground.
12	RFN	RF output, negative terminal. Nominal DC voltage is 2.4V. Output should be AC-coupled.
13	RFP	RF output, positive terminal. Nominal DC voltage is 2.4V. Output should be AC-coupled.
14	VEE	Ground.
15	VCC	Positive supply (+5V).
16	BBQN	Q-channel baseband input, negative terminal. Nominal DC bias voltage is 1.9V (biased internally).

Suggested Pad Layout

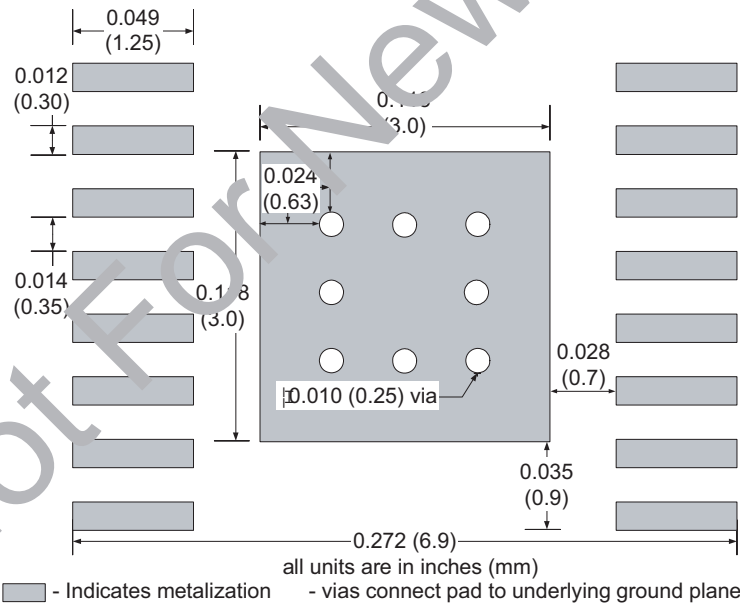

Package Drawing

Dimensions in inches (millimeters)

Refer to drawing posted at www.rfmd.com for tolerances.

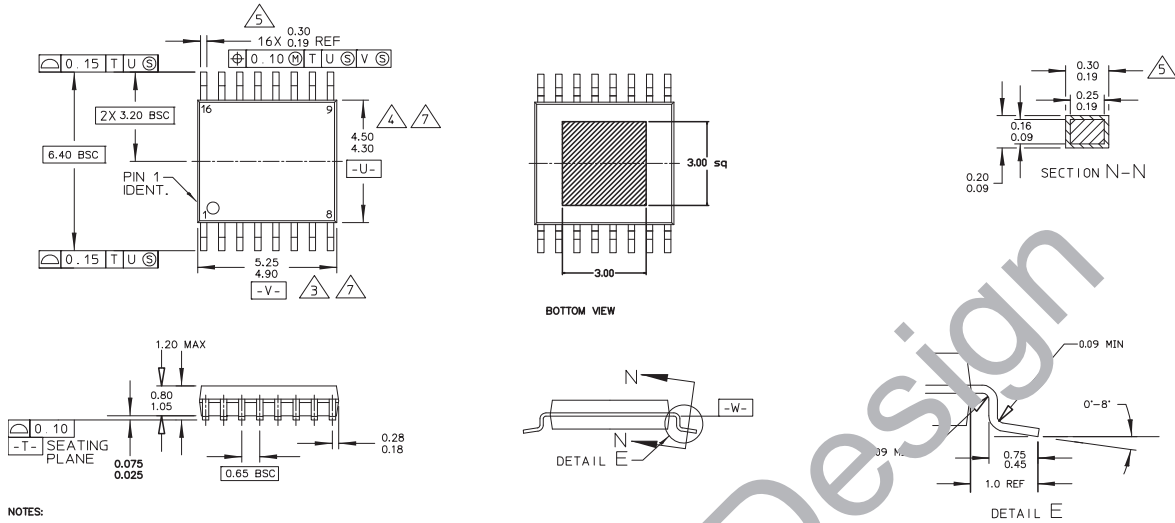

- NOTES:**
1. CONTROLLING DIMENSION: MILLIMETER
 2. DIMENSIONS AND TOLERANCES PER ANSI Y14.5M-1982.
 3. DIMENSION DOES NOT INCLUDE MOLD FLASH, PROTRUSIONS OR GATE BURRS. MOLD FLASH OR GATE BURRS SHALL NOT EXCEED 0.15 PER SIDE
 4. DIMENSION DOES NOT INCLUDE INTERLEAD FLASH OR PROTRUSION INTERLEAD FLASH OR PROTRUSION SHALL NOT EXCEED 0.25 PER SIDE.
 5. DIMENSION DOES NOT INCLUDE DAMBAR PROTRUSION. ALLOWABLE DAMBAR PROTRUSION SHALL BE 0.08 TOTAL IN EXCESS OF THE DIMENSION AT MAXIMUM MATERIAL CONDITION.
 6. TERMINAL NUMBERS ARE SHOWN FOR REFERENCE ONLY.
 7. DIMENSIONS ARE TO BE DETERMINED AT DATUM PLANE [-W-].

Not For New Design

Application Schematic

250 MHz to 1000 MHz Application Schematic

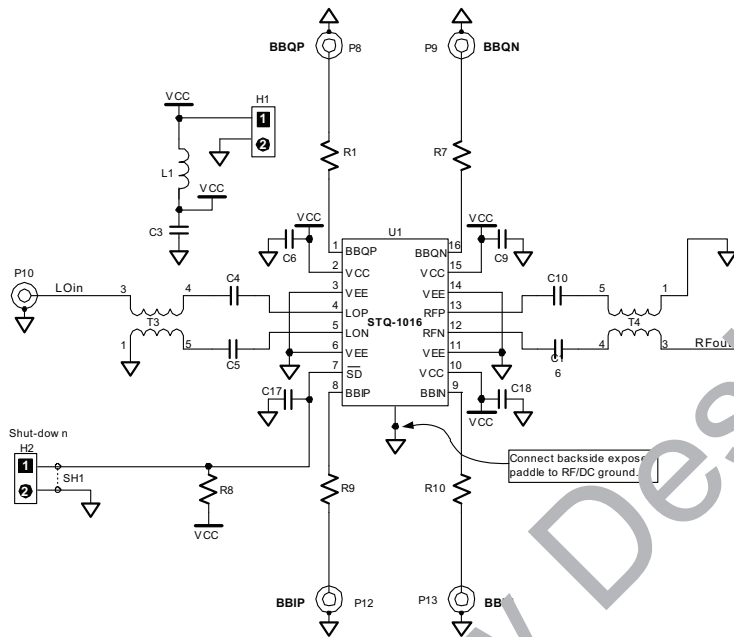

Direct Quadrature Modulator: General Test Set-Up

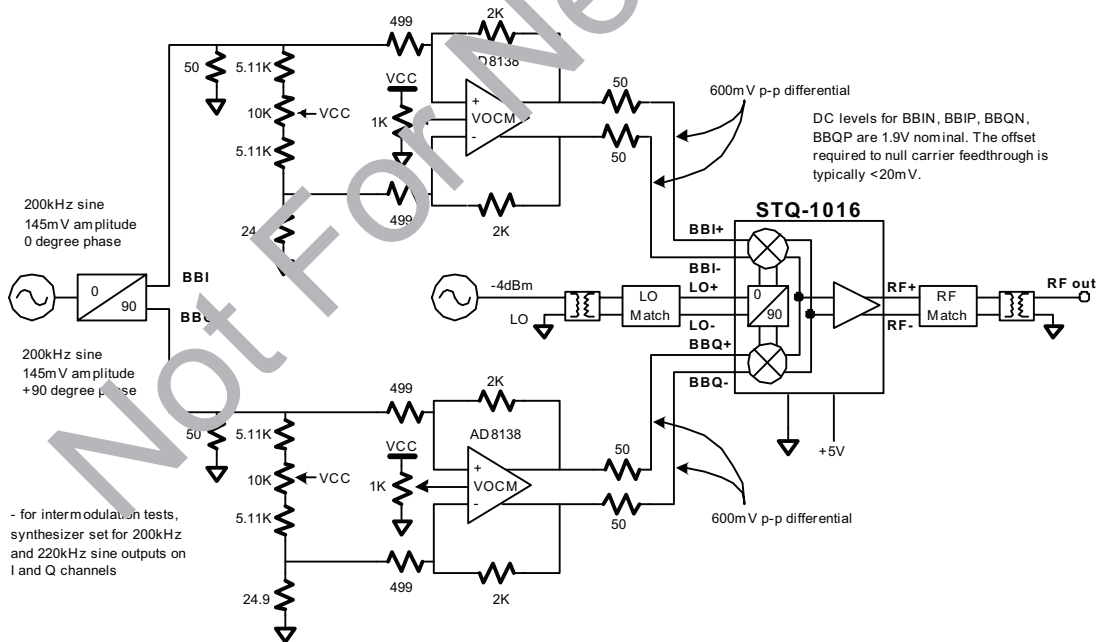

Bill of Materials (for 250MHz to 1000MHz Evaluation Board P/N STQ-1016EVB)

Component Designator	Value	Qty	Vendor	Part Number	Description
U1		1	SMDI	STQ-1016	SiGe Direct Quadrature Modulator
P8, P9, P10, P11, P12, P13		6	Johnson Components	142-0701-851	SMA connector, end launch with tab, for 0.062" thick board
H1, H2		2	AMP	640453-2	2-pin header, right angle
T3, T4	1:1	2	M/A COM	ETC1-1-13	RF transformer, 4.5MHz to 3000MHz
L1	1uH	1	Panasonic	ELJ-FA1R0KF2	Inductor, 1210 footprint, ±10% tolerance
R1, R7, R9, R10	200Ω	4	Venkel	CR1206-8W-2000T	Resistor, 1206 footprint, ±1% tolerance
R8	1kΩ	1	Venkel	CRO603-16W-1001FT	Resistor, 0603 footprint, ±1% tolerance
C6, C18	33pF	2	Venkel	C0603COG500-330JNE	Capacitor, 0603 footprint, COG dielectric, ±5% tolerance
C9, C17	1nF	2	Venkel	C0603COG500-102JNE	Capacitor, 0603 footprint, COG dielectric, ±5% tolerance
C3	2.2uF	1	Venkel	C1206Y5V160-225ZNE	Capacitor, 1206 footprint, Y5V dielectric, 16V rating
C4, C5, C10, C16	22pF	4	Venkel	C0603COG500-220JNE	Capacitor, 0603 footprint, COG dielectric, ±5% tolerance
SH1		1	3M	929950-00	Shunt for 2-pin header

Ordering Information



Part Number	Reel Size	Devices/Reel
STQ-1016(Z)	7"	1000

Not For New Design

Not For New Design

Looking for pricing, stock, or lifecycle information?

Click below to explore more details on WIN SOURCE:

-  [View STQ-1016 on WIN SOURCE](#)
-  [RF Micro Devices Information](#)

Optimize Your Supply Chain with WIN SOURCE Solutions

-  Global Sourcing Solution
-  Obsolete Management
-  Cost Control Management
-  Shortage Management
-  Alternative Solution
-  Excess Inventory Management