



# THE DATASHEET OF STM8T143-EVAL



### Introduction

The STM8T143-EVAL evaluation kit helps you to discover the touch and proximity capacitive sensor features of the STM8T143 microcontroller and to develop your applications easily. It is based on an STM8T143AM62 microcontroller and includes a controller board with the STM8T143, a programming / data streaming board and five electrode boards.

**Figure 1. STM8T143-EVAL evaluation kit**



*Table 1* lists the applicable tools concerned by this user manual.

**Table 1. Applicable tools**

Type	Applicable products
Development tools	STM8T143-EVAL

# Contents

- 1 Quick start ..... 6**
  - 1.1 System requirements ..... 6
  - 1.2 Development tools ..... 6
  - 1.3 Ordering code ..... 6
  - 1.4 Naming conventions ..... 6
  - 1.5 Getting started ..... 7
  
- 2 Evaluation kit description ..... 8**
  - 2.1 Overview ..... 8
  - 2.2 Controller board (MB972) description ..... 9
    - 2.2.1 Power supply ..... 9
    - 2.2.2 LD1 and LD2 LEDs ..... 9
    - 2.2.3 JP1 jumper (IDD) ..... 9
    - 2.2.4 SB1 and SB2 solder bridges ..... 10
    - 2.2.5 CN1 and CN2 control and data streaming board connectors ..... 10
    - 2.2.6 CN3 and CN4 programming and electrode board connectors ..... 11
  - 2.3 Programming and data streaming board (MB973) description ..... 11
    - 2.3.1 CN1, CN2, CN3 and CN5 connectors description ..... 12
    - 2.3.2 CN4 ST-TSLink connector ..... 14
  - 2.4 Electrode board descriptions ..... 16
  
- 3 Advanced evaluation ..... 17**
  - 3.1 Standalone mode ..... 17
  - 3.2 Programming mode ..... 19
  - 3.3 Data streaming mode ..... 21
  - 3.4 How to evaluate your own electrode ..... 23
  - 3.5 ST-TSLINK dongle ..... 23
    - 3.5.1 On-board programming of the STM8T143 microcontroller ..... 24
    - 3.5.2 Monitor STM8T143 internal parameters in Data streaming mode ..... 25
  
- 4 Electrode performances ..... 28**
  
- 5 Troubleshooting ..... 30**

---

<b>6</b>	<b>Board schematics</b> .....	<b>31</b>
6.1	Controller board (MB972) .....	31
6.2	Programming and data streaming board (MB973) .....	32
<b>Appendix A</b>	<b>Board layout</b> .....	<b>33</b>
A.1	MB972 board layout .....	33
A.2	MB973 board layout .....	36
A.3	Electrode board layouts .....	39
	<b>Revision history</b> .....	<b>42</b>

## List of tables

Table 1.	Applicable tools . . . . .	1
Table 2.	Jumper and solder bridge ON/OFF naming conventions . . . . .	6
Table 3.	SB1 and SB2 solder bridge descriptions . . . . .	10
Table 4.	MB972 CN1 connector description . . . . .	10
Table 5.	MB972 CN2 connector description . . . . .	10
Table 6.	MB972 CN3 connector description . . . . .	11
Table 7.	MB972 CN4 connector description . . . . .	11
Table 8.	MB973 CN1 connector description . . . . .	12
Table 9.	MB973 CN2 connector description . . . . .	12
Table 10.	MB973 CN3 connector description . . . . .	13
Table 11.	MB973 CN5 connector description . . . . .	13
Table 12.	MB973 CN4 connector description . . . . .	14
Table 13.	Summary of electrode boards. . . . .	16
Table 14.	Troubleshooting . . . . .	30
Table 15.	Document revision history . . . . .	42

## List of figures

Figure 1.	STM8T143-EVAL evaluation kit	1
Figure 2.	MB976 electrode board connected to MB972 controller board	7
Figure 3.	MB972 controller board	9
Figure 4.	MB973 programming and data streaming board	12
Figure 5.	ST-TSLINK programming dongle	14
Figure 6.	MB976 electrode board	16
Figure 7.	Hardware block diagram for standalone mode	17
Figure 8.	MB976 electrode board connected to MB972 controller board	18
Figure 9.	Boards plugging to a USB connector	18
Figure 10.	Hardware block diagram for programming mode	19
Figure 11.	MB973/MB972 board assembly connected to ST-TSLINK dongle	20
Figure 12.	MB973/MB972 board assembly and ST-TSLINK dongle with USB connector	20
Figure 13.	Hardware block diagram for data streaming mode	21
Figure 14.	Connectors MB972 CN1-CN2 connected to connectors MB973 CN3-CN5	22
Figure 15.	Plugging the electrode board onto MB972	22
Figure 16.	Electrode connection	23
Figure 17.	STVP programming window	24
Figure 18.	STVP device selection	25
Figure 19.	Typical configuration for Data streaming mode	25
Figure 20.	STM Studio GUI	26
Figure 21.	STM Studio internal parameters	27
Figure 22.	MB974 electrode board	28
Figure 23.	MB975 electrode board	28
Figure 24.	MB976 electrode board	29
Figure 25.	MB1022 electrode board	29
Figure 26.	MB1025 electrode board	29
Figure 27.	STM8T143-EVAL controller board (MB972)	31
Figure 28.	STM8T143-EVAL Programming and data streaming board (MB973)	32
Figure 29.	MB972 mechanical drawing	33
Figure 30.	MB972 top silkscreen	34
Figure 31.	MB972 top layer	34
Figure 32.	MB972 bottom silkscreen	35
Figure 33.	MB972 bottom layer	35
Figure 34.	MB973 mechanical drawing	36
Figure 35.	MB973 top silkscreen	37
Figure 36.	MB973 top layer	37
Figure 37.	MB973 bottom silkscreen	38
Figure 38.	MB973 bottom layer	38
Figure 39.	MB974 electrode board	39
Figure 40.	MB975 electrode board	39
Figure 41.	MB976 electrode board	40
Figure 42.	MB1022 electrode board	40
Figure 43.	MB1025 electrode board	41

# 1 Quick start

The STM8T143-EVAL is a low-cost and easy-to-use evaluation kit to quickly evaluate and start a development with an STM8T143 device.

For more information on STM8T143-EVAL, visit [www.st.com](http://www.st.com) to discover the STM8T143 features and to easily develop your applications. It includes everything required for beginners and experienced users to get started quickly.

## 1.1 System requirements

- Windows PC (XP, Vista, 7)
- ST-TSLINK programming dongle

## 1.2 Development tools

- STM-STUDIO - STMicroelectronics at [www.st.com](http://www.st.com).

## 1.3 Ordering code

To order an STM8T143 evaluation kit, use the STM8T143-EVAL ordering code.

## 1.4 Naming conventions

[Table 2](#) provides the definition of some conventions used in the present document.

**Table 2. Jumper and solder bridge ON/OFF naming conventions**

Convention	Definition
Jumper JP1 ON	Jumper fitted
Jumper JP1 OFF	Jumper not fitted
Solder bridge SBx ON	SBx connections closed by solder
Solder bridge SBx OFF	SBx connections left open

## 1.5 Getting started

1. Place jumper JP1 on the MB972 controller board to the “on” position.
2. Connect the MB976 electrode board to the MB972 controller board as shown in [Figure 2](#).

**Figure 2. MB976 electrode board connected to MB972 controller board**



3. Connect the USB connector of the MB972 controller board to your PC.
4. Verify that the red LED, LD1 (Prox/Touch), lights up.
5. Move your hand away from the board and wait 1 second.
6. Each time your hand comes close to the MB976 electrode board, the red LED (LD1) should switch off.
7. To study or modify the proximity or touch functions of this product, visit [www.st.com](http://www.st.com).

## 2 Evaluation kit description

### 2.1 Overview

STM8T143-EVAL evaluation kit offers the following features:

- Configuration through the one-time programmable option bytes with the Programming and Data Streaming board connected to the ST-TSLINK programming dongle driven by the STVP - ST Visual Programmer software.
- Monitoring of the STM8T143 internal capacitive sensing parameters in Data Streaming mode with the MB973 Programming and Data Streaming board connected to the ST-TSLINK programming dongle driven by the STM-STUDIO software.

#### **Main controller board (MB972)**

- STM8T143AM62 microcontroller in an SO8 package to make it easy to replace the device during evaluation.
- Power supply via the USB connection or from the ST-TSLINK programming dongle.
- 2 LEDs to indicate the detection state:
  - LD1 (red) for proximity/touch detection
  - LD2 (green) for proximity detection (depending on the STM8T143 option bytes settings)
- Jumper JP1 (IDD) for consumption measurement.

#### **5 electrode boards with different ground planes:**

- Square electrode with no ground plane
- Square electrode with 15% ground plane
- Square electrode with 100% ground plane
- Square electrode with ground ring and plane
- Ring electrode with no ground plane

#### **Programming and data streaming board (MB973)**

- Proximity or touch or dual output depending on STM8T143 configuration.

## 2.2 Controller board (MB972) description

The STM8T143 device is directly mounted on the MB972 controller board which features two LEDs to display the state of the proximity and touch outputs.

**Figure 3. MB972 controller board**



### 2.2.1 Power supply

The power supply is provided either by the host PC through the USB cable connected to connector CN5, or by the ST-TSLINK through the programming and data streaming board.

### 2.2.2 LD1 and LD2 LEDs

- LD1 Prox/Touch: the red LED indicates the proximity or touch detection depending on the option bytes value.
- LD2 Prox: the green LED indicates the proximity detection depending on the option bytes settings.

### 2.2.3 JP1 jumper (IDD)

Jumper JP1, labeled IDD, is used to supply power to or measure the power consumption of the STM8T143AM62 MCU.

- Jumper on: STM8T143AM62 is powered (default).
- Jumper off: an ammeter must be connected to measure the STM8T143AM62 current. (if there is no ammeter, the STM8T143AM62 is not powered).

### 2.2.4 SB1 and SB2 solder bridges

**Table 3. SB1 and SB2 solder bridge descriptions**

Bridge	State <sup>(1)</sup>	Description
SB1 (CX)	<b>ON</b>	CX signal is connected to CN4 and can be used by the ST-TSLINK
	OFF	CX signal is not connected to CN4 to avoid noise. Can only be used in Standalone mode.
SB2 (VREG)	<b>ON</b>	VREG signal is connected to CN3 and can be used by the ST-TSLINK
	OFF	VREG signal is not connected to CN3 to avoid noise. Can only be used in Standalone mode.

1. Default SBx state is shown in bold.

### 2.2.5 CN1 and CN2 control and data streaming board connectors

Connectors CN1 and CN2 are used to connect the MB972 controller board to the MB973 programming and data streaming board.

**Table 4. MB972 CN1 connector description**

Pin	CN1	Designation
1	GND	Ground
2	OUT/TOUT/DATA	Pin 1 of the STM8T143 Pin 5 of the CN4 Pin 5 of the CN2 of MB973 Pin 2 of the CN3 of MB973 Pin 10 of the CN4 of MB973
3	CTRL/POUT	Pin 8 of the STM8T143 Pin 6 of CN4 Pin 3 of CN3 of MB973 through R1 Pin 12 of CN4 of MB973 through R1
4	VDD	Pin 5 of the STM8T143 Pin 4 of CN4 Pin 6 of CN2 of MB973 Pin 4 of CN3 of MB973 Pin 5 of CN4 of MB973

**Table 5. MB972 CN2 connector description**

Pin	CN2	Designation
1	GND	Ground
2	GND	Ground
3	GND	Ground
4	GND	Ground

## 2.2.6 CN3 and CN4 programming and electrode board connectors

Connectors CN3 and CN4 are used to connect the electrode boards to the MB972 controller board.

**Table 6. MB972 CN3 connector description**

Pin	CN3	Designation
1	GND	Ground
2	GND	Ground
3	GND	Ground
4	GND	Ground
5	GND	Ground
6	VREG_SB2	Pin 7 of the STM8T143 if SB2 fitted, else NC

**Table 7. MB972 CN4 connector description**

Pin	CN4	Designation
1	GND	Ground
2	Electrode	Pin 4 of the STM8T143 Electrode through RC filter
3	CX_SB1	Pin 4 of the STM8T143 if SB1 fitted, else NC
4	VDD	Pin 5 of the STM8T143 Pin 4 of CN1 Pin 6 of CN2 of MB973 Pin 5 of CN3 of MB973 Pin 5 of CN4 of MB973
5	OUT/TOUT/DATA	Pin 1 of the STM8T143 Pin 2 of CN1 Pin 5 of CN2 of MB973 Pin 2 of CN3 of MB973 Pin 10 of CN4 of MB973
6	CTRL/POUT	Pin 8 of the STM8T143 Pin 3 of CN1 Pin 6 of CN2 Pin 3 of CN3 of MB973 Pin 12 of CN4 of MB973 through R1

## 2.3 Programming and data streaming board (MB973) description

The programming and data streaming board (MB973) is used to connect the MB972 controller board to the ST-TSLINK programming dongle. Depending on how this board is connected to the controller board, it is either possible to program the STM8T143 device option bytes or to monitor the STM8T143 internal capacitive sensing parameters.

**Figure 4. MB973 programming and data streaming board**



### 2.3.1 CN1, CN2, CN3 and CN5 connectors description

Connectors CN1, CN2, CN3 and CN5 are used to connect the programming and data streaming board to the controller board.

- CN1 and CN2 are used to program the STM8T143 option bytes.
- CN3 and CN5 are used to monitor STM8T143 internal capacitive sensing parameters.

**Table 8. MB973 CN1 connector description**

Pin	CN1	Designation
1	GND	Ground
2	GND	Ground
3	GND	Ground
4	NC	Not Connected
5	GND	Ground
6	VREG_PROG	Pin 7 of the STM8T143 if SB2 fitted, else NC

**Table 9. MB973 CN2 connector description**

Pin	CN2	Designation
1	GND	Ground
2	NC	Not Connected
3	CX	Pin 4 of the STM8T143 if SB1 fitted, else NC
4	VDD_PROG	ST-TSLink VDD (programming supply) Pin 3 of CN4 Pin 7 of the STM8T143 of MB972 Pin 4 of CN4 of MB972

**Table 9. MB973 CN2 connector description (continued)**

Pin	CN2	Designation
5	OUT/TOUT/DATA	Pin 5 of CN4 Pin 2 of CN3 Pin 10 of CN4 Pin 1 of the STM8T143 of MB972 Pin 2 of CN1 of MB972
6	CTRL/POUT	Pin 4 of CN3 Pin 5 of CN4 R1 Pin 8 of the STM8T143 of MB972 Pin 4 of CN1 of MB972 Pin 4 of CN4 of MB972

**Table 10. MB973 CN3 connector description**

Pin	CN3	Designation
1	GND	Ground
2	OUT/TOUT/DATA	Pin 5 of the CN2 Pin 10 of the CN4 Pin 1 of the STM8T143 of MB972
3	CTRL/POUT	Pin 12 of CN4 through R1 Pin 3 of CN1 of MB972 Pin 8 of the STM8T143 of MB972 Pin 6 of CN4 of MB972
4	VDD	Pin 6 of CN2 Pin 5 of CN4 Pin 5 of the STM8T143 of MB972 Pin 4 of CN4 of MB972 Pin 4 of CN1 of MB972

**Table 11. MB973 CN5 connector description**

Pin	CN5	Designation
1	GND	Ground
2	GND	Ground
3	GND	Ground
4	GND	Ground

### 2.3.2 CN4 ST-TSLink connector

Connector CN4 is used to connect the ST-TSLINK programming dongle.

**Figure 5. ST-TSLINK programming dongle**



**Table 12. MB973 CN4 connector description**

Pin	CN4	Designation
1	GND	Ground
2	NC	Not Connected
3	VDD_PROG	ST-TSLink VDD (programming supply) Pin4 of CN2 Pin 7 of the STM8T143 of MB972 Pin 4 of CN4 of MB972
4	VREG_PROG	ST-TSLink VREG (Programming regulator monitoring) Pin 7 of the STM8T143 of MB972 if SB2 fitted, else NC
5	VDD_DATA_STREAMING/ CLK_PROG	ST-TSLink I/O1 (VDD output in data streaming mode or programming clock) Pin 6 of CN2 Pin 4 of CN3 Pin 5 of the STM8T143 of MB972 Pin 4 of CN4 of MB972
6	DATA_PROG	ST-TSLink PROG DATA if SB1 fitted, else NC
7	NC	Not Connected
8	NC	Not Connected
9	NC	Not Connected

**Table 12. MB973 CN4 connector description (continued)**

Pin	CN4	Designation
10	DATA_STREAMING	ST-TSLink DATA (data streaming input) Pin 5 of CN4 Pin 2 of CN3 Pin 1 of the STM8T143 of MB972 Pin 2 of CN1 of MB972
11	NC	Not Connected
12	CTRL	ST-TSLink I/O2 (control pin management) Pin 3 of CN3 through R1 Pin 3 of CN1 of MB972 through R1 Pin 8 of the STM8T143 of MB972 through R1 Pin 6 of CN4 of MB972 through R1
13	NC	Not Connected
14	NC	Not Connected
15	NC	Not Connected
16	NC	Not Connected
17	NC	Not Connected
18	NC	Not Connected
19	GND	Ground
20	NC	Not Connected

## 2.4 Electrode board descriptions

Five electrode boards, MB974, MB975, MB976, MB1022 and MB1025, are included in the STM8T143-EVAL evaluation kit.

The goal is to demonstrate the impact on the detection range and directivity depending on the shape and size of the electrode and on the ground surrounding it.

All electrode boards are exactly the same size and fit on the MB972 controller board as shown in [Figure 2](#).

The layouts of each of the specific electrode boards are provided in [Appendix A.3: Electrode board layouts on page 39](#).

**Table 13. Summary of electrode boards**

Board	Description
MB974	Square electrode with no ground plane
MB975	Square electrode with 15% ground plane
MB976	Square electrode with 100% ground plane
MB1022	Ring electrode with no ground plane
MB1025	Square electrode with ground ring and plane

**Figure 6. MB976 electrode board**



### 3 Advanced evaluation

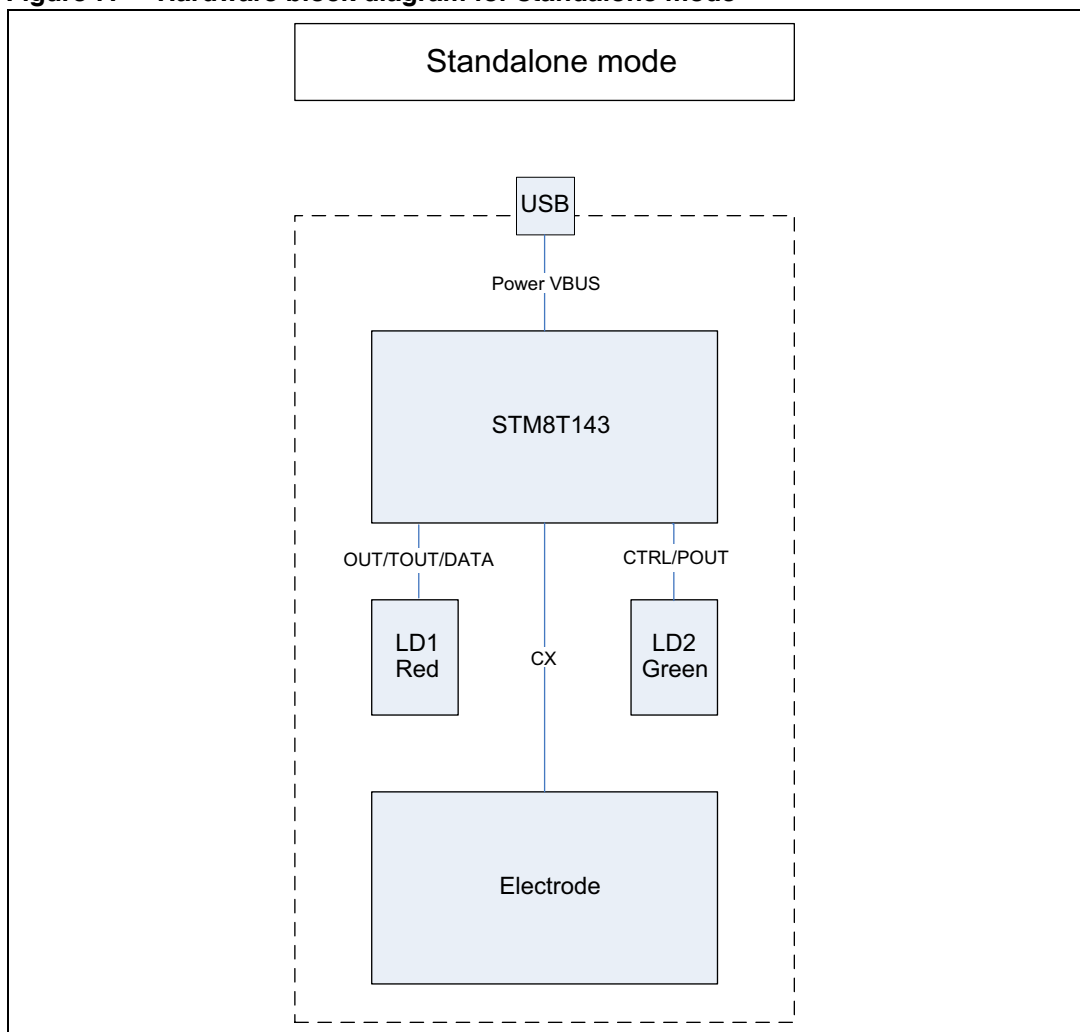
The STM8T143-EVAL evaluation kit offers three different operating modes:

- Standalone mode
- Programming mode
- Data streaming mode

#### 3.1 Standalone mode

This mode allows to test the performance of a defined electrode board. In this mode, the state of the proximity and touch outputs is indicated by LEDs LD1 and LD2.

**Figure 7. Hardware block diagram for standalone mode**



1. Plug the MB976 electrode board onto the MB972 controller board as shown below.

**Figure 8. MB976 electrode board connected to MB972 controller board**



2. Connect the USB connector of the MB972 controller board to your PC. LEDs LD1 and LD2 will light up, depending on your option bytes configuration.

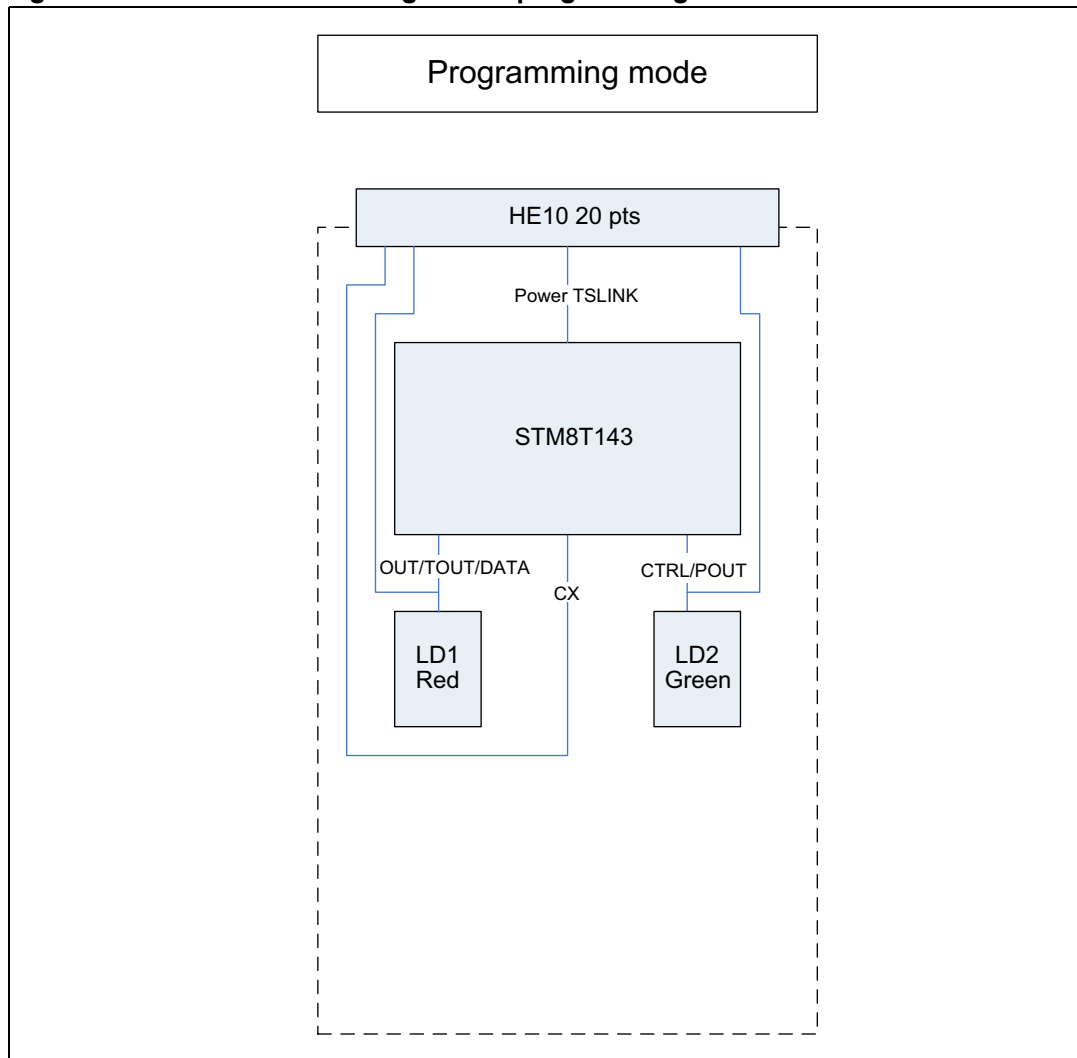
**Figure 9. Boards plugging to a USB connector**



## 3.2 Programming mode

This mode is used to program the STM8T143 option bytes. Configure the ST-TSLink dongle and the STVP tool as follows to enter Programming mode:

**Figure 10. Hardware block diagram for programming mode**



1. Plug the MB973 board onto the MB972 board and connect the ST-TSLINK dongle using the provided flat cable, as shown below.

**Figure 11. MB973/MB972 board assembly connected to ST-TSLINK dongle**



2. Plug the ST-TSLINK dongle to a USB connector on your PC.

**Figure 12. MB973/MB972 board assembly and ST-TSLINK dongle with USB connector**

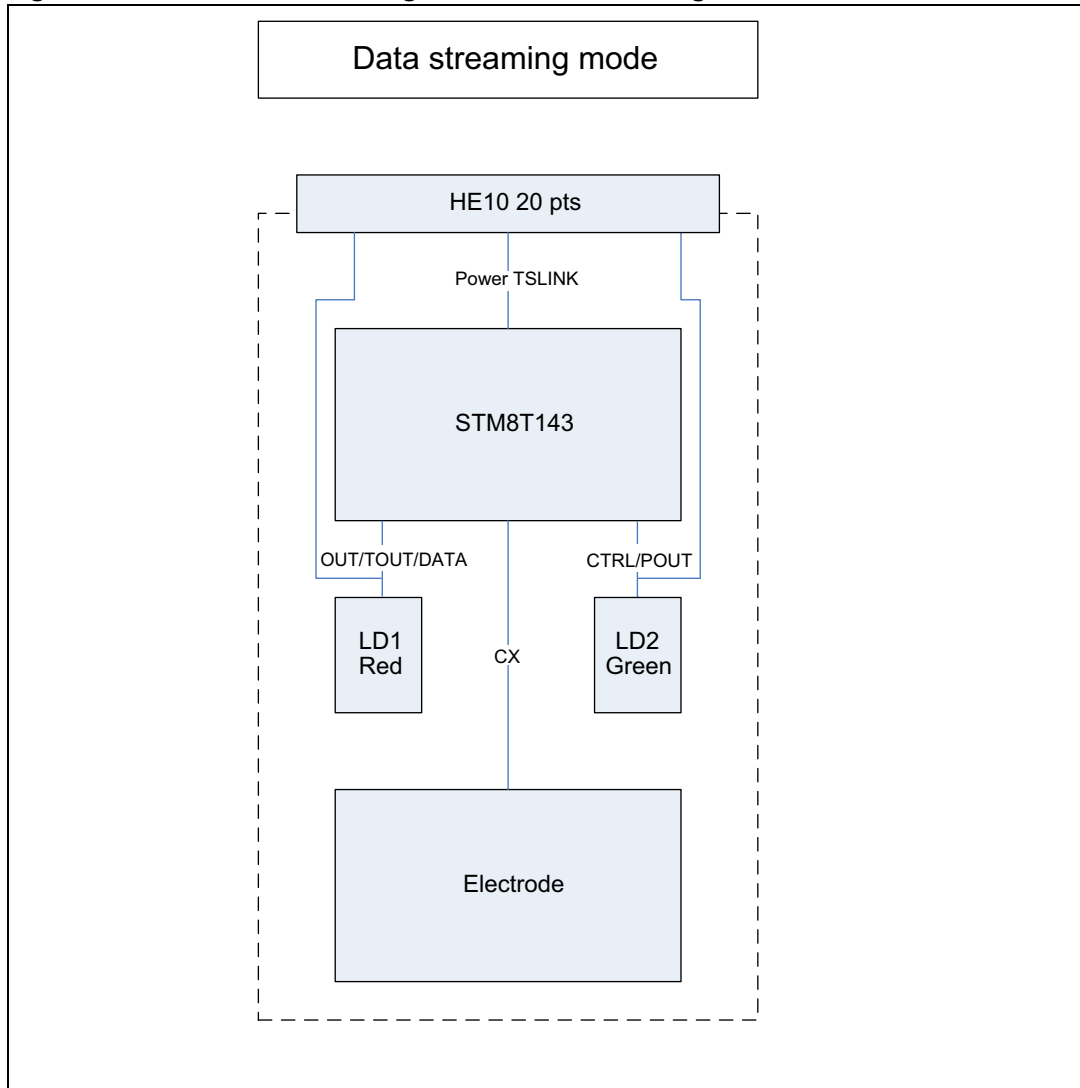


3. Run STVP Software Tool on your PC.  
(STVP is available at [www.st.com](http://www.st.com))

### 3.3 Data streaming mode

This mode is used to monitor the STM8T143 internal capacitive sensing parameters using the STM Studio utility.

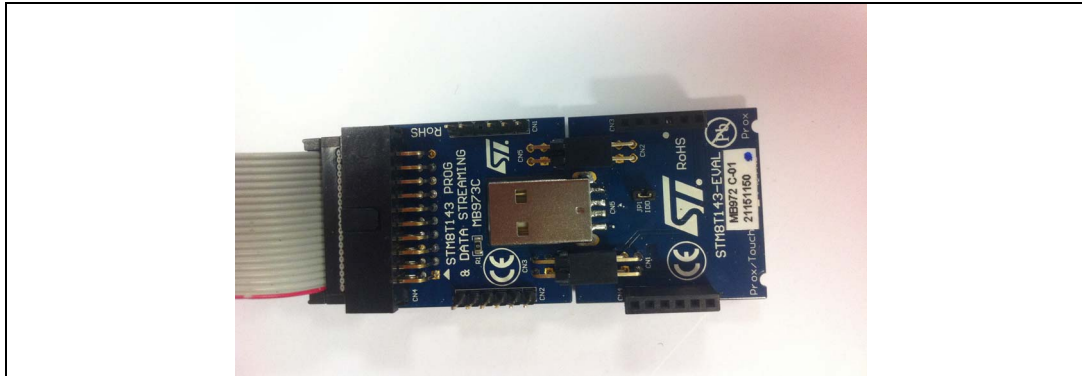
**Figure 13. Hardware block diagram for data streaming mode**



*Note:* To use this mode, the data streaming mode device option bit must be programmed first.

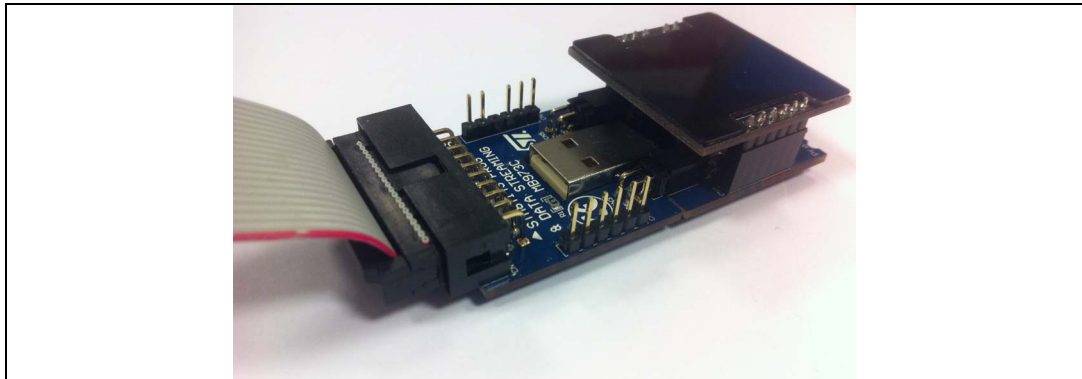
1. Connect connectors CN1-CN2 of the MB972 board to connectors CN3-CN5 of the MB973 board as shown below.

**Figure 14. Connectors MB972 CN1-CN2 connected to connectors MB973 CN3-CN5**



2. Plug the required electrode board onto the MB972 board as shown below.

**Figure 15. Plugging the electrode board onto MB972**

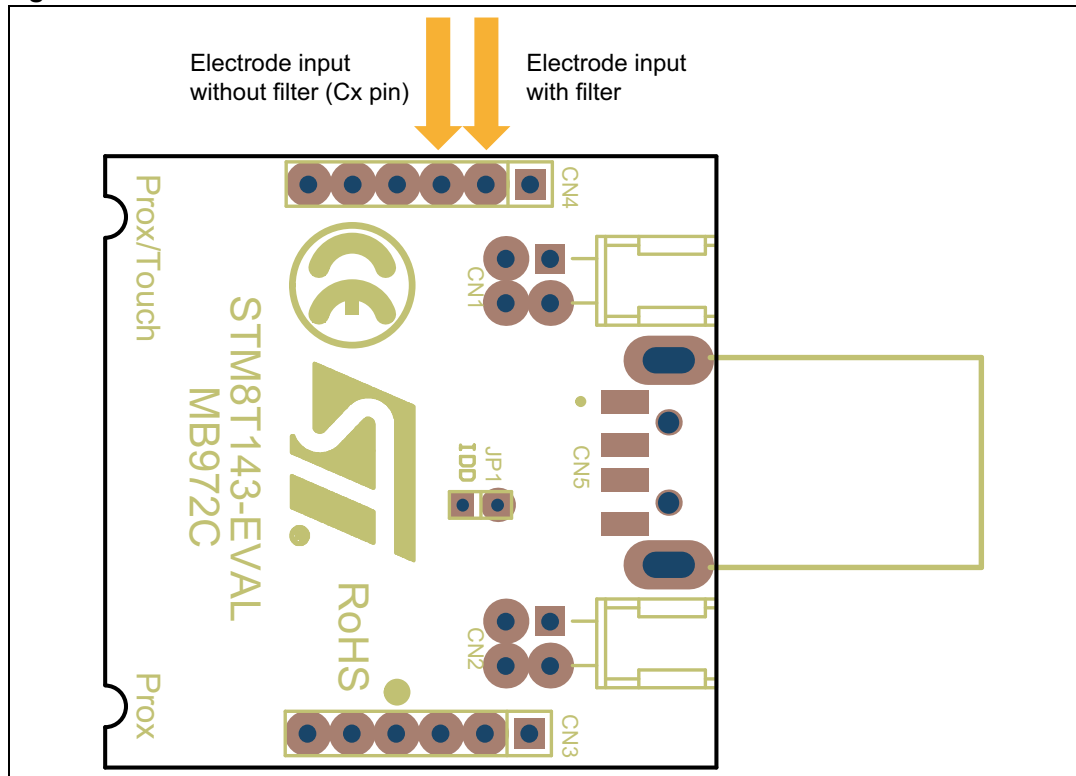


3. Plug the ST-TSLINK probe to a USB connector on your PC.
4. Run STM Studio on your PC.  
(STM-STUDIO is available at [www.st.com](http://www.st.com))

### 3.4 How to evaluate your own electrode

You can test your own electrode by connecting it to Pin 2 of the CN4 connector if using the onboard RC filter, or to Pin 3 for direct access to the Cx pin of the device. It is also recommended to unsolder connector C6 to remove the extra capacitance due to unused components.

**Figure 16. Electrode connection**



### 3.5 ST-TSLINK dongle

ST-TSLINK dongle is the tool used for the STM8T143-EVAL evaluation kit. The ST-TSLINK dongle can be used in 2 different ways:

- For on-board programming of the STM8T143 microcontroller
- To monitor STM8T143 internal capacitive sensing parameters in Data Streaming mode

For information about programming features, refer to the UM0795 user manual, which describes in detail all the ST-TSLINK features.

### 3.5.1 On-board programming of the STM8T143 microcontroller

STVP v3.2.5 or later versions support the STM8T143 device rev 2. Please configure the STVP tool with the settings shown in [Figure 17](#).

Figure 17. STVP programming window

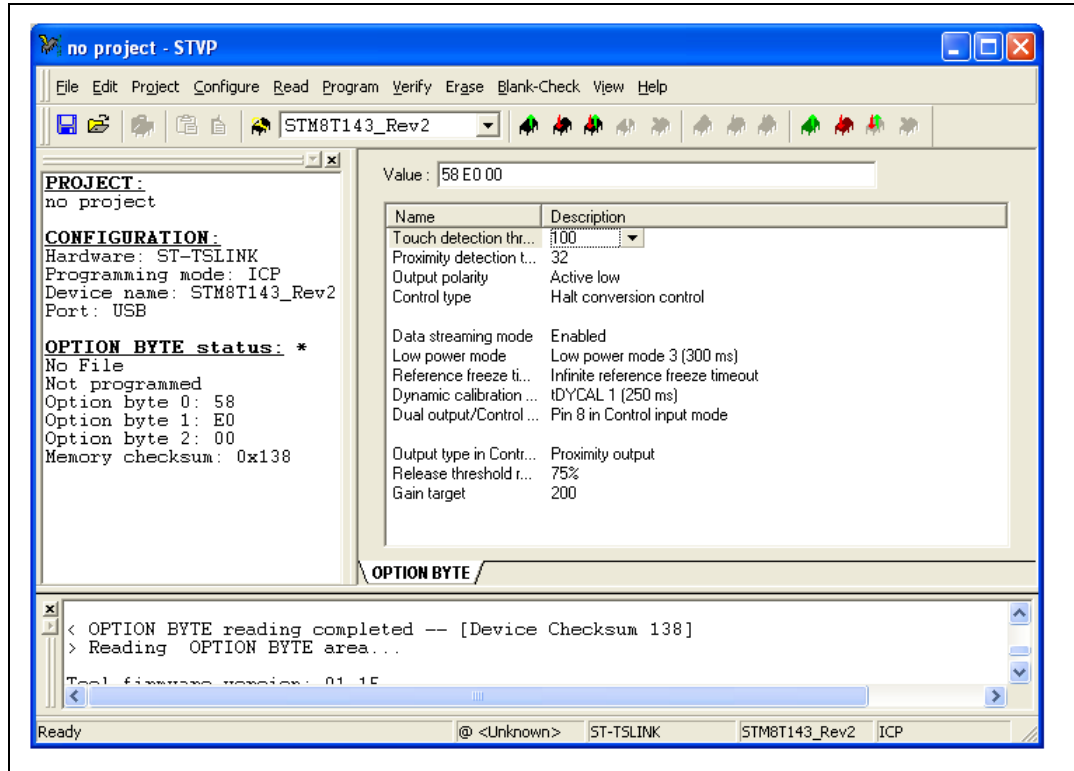
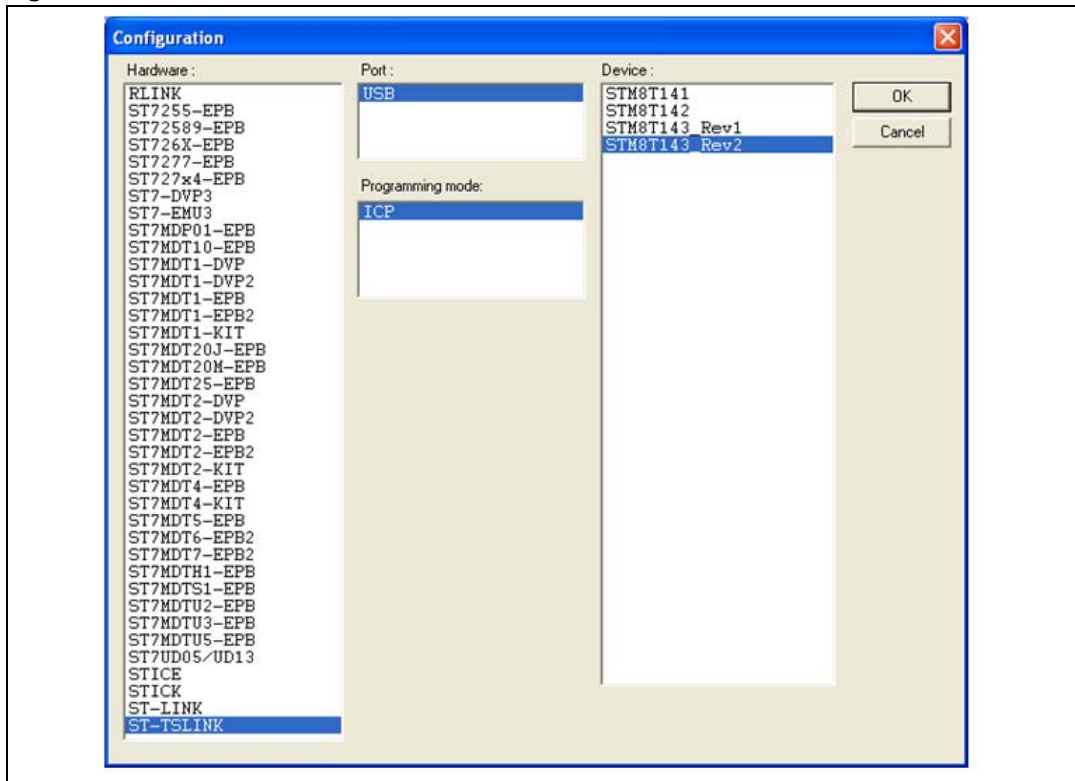


Figure 18. STVP device selection



### 3.5.2 Monitor STM8T143 internal parameters in Data streaming mode

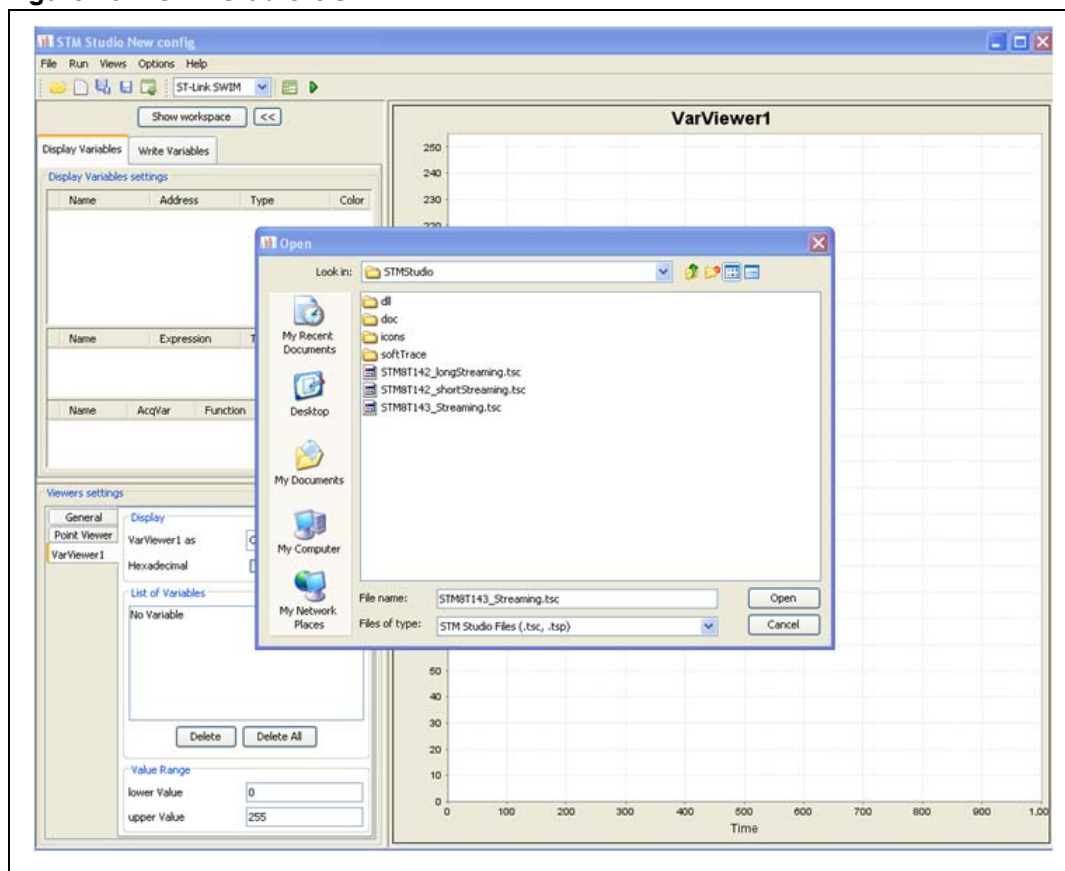
The STM8T143 device can be programmed in Data streaming mode through option bits. Please refer to STM8T143 datasheet.

In Data streaming mode, the device internal parameters can be monitored through STM Studio graphical user interface (see [Figure 20](#)) using ST-TSLink dongle (see [Figure 19](#)).

Figure 19. Typical configuration for Data streaming mode

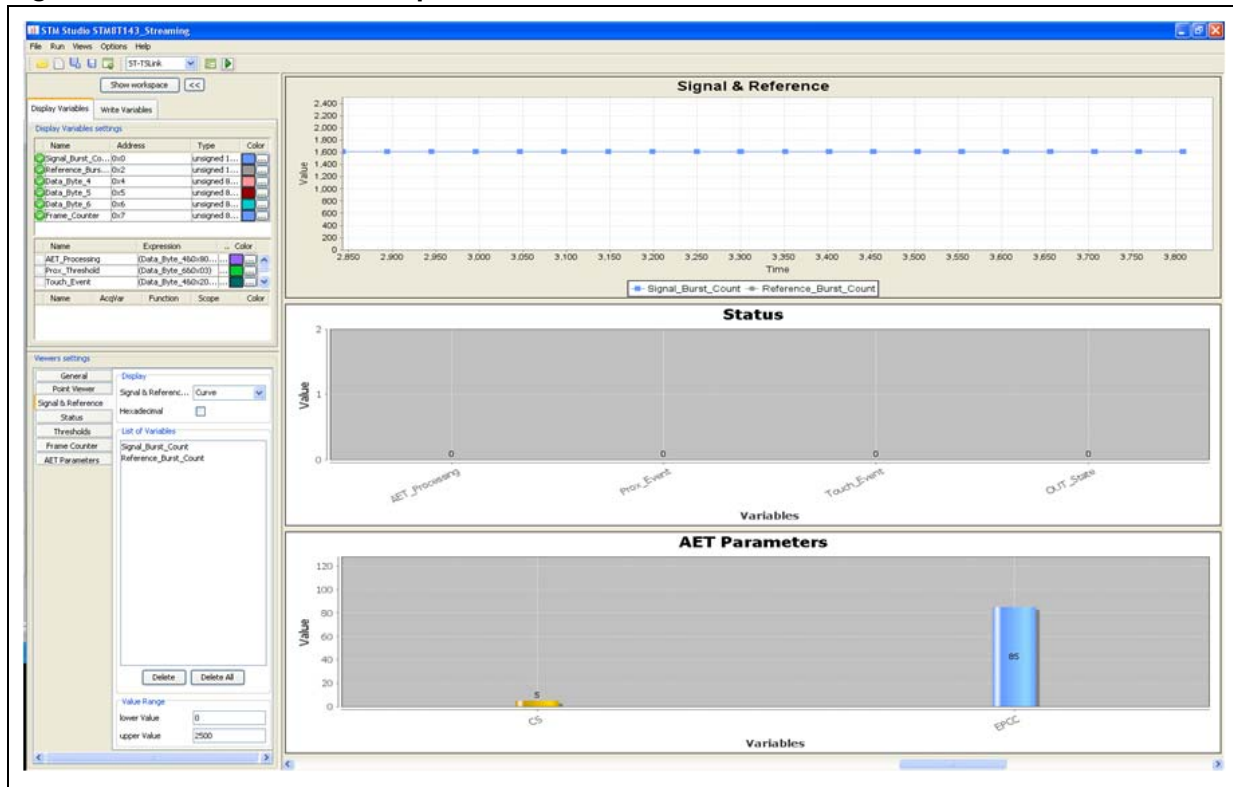


Figure 20. STM Studio GUI



To configure STM Studio for the STM8T143 device, please load "STM8T143\_Streaming.tsc" file.

Figure 21. STM Studio internal parameters



Then start the acquisition.

Internal parameters are displayed in different windows (see [Figure 21](#)).

This tool is very useful in the design phase: the signal and reference levels provide information on system sensitivity or noise levels, while the CS and EPCC values reflect the parasitic capacitance of your electrode. Thus, the designer can optimize the sensor integration strategy by monitoring the impact on the CS and EPCC values.

## 4 Electrode performances

The 5 electrode boards included in the package demonstrate how to obtain detection directivity and show the effect of the ground shielding strategy on the performance. For each electrode board, the detection distance is given on X, Y and Z axes. Depending on the electrode board design, the device compensates the parasitic capacitance through the AET process. The compensation parameters given by CS and EPCC values reflect the parasitic capacitance for each sensing electrode.

Figure 22. MB974 electrode board

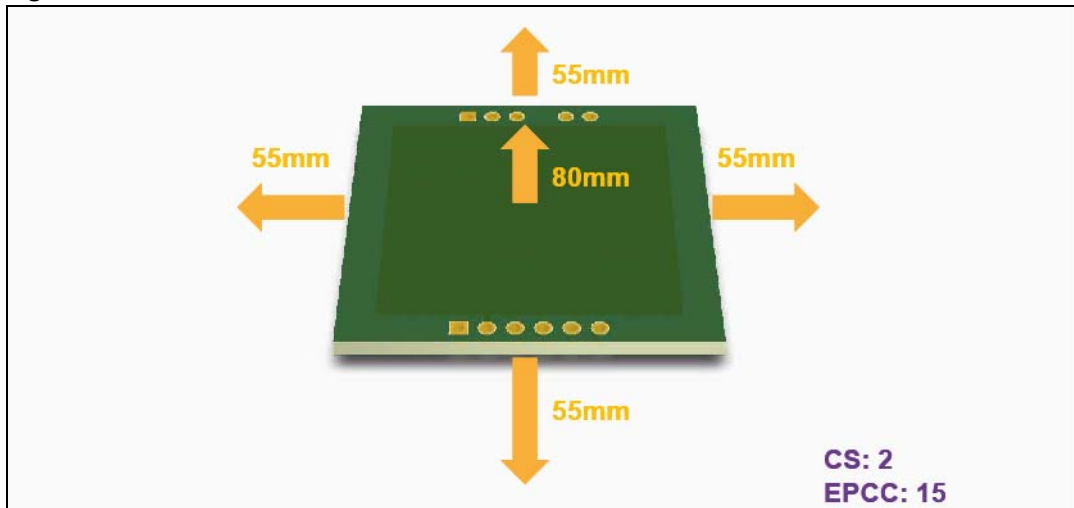


Figure 23. MB975 electrode board

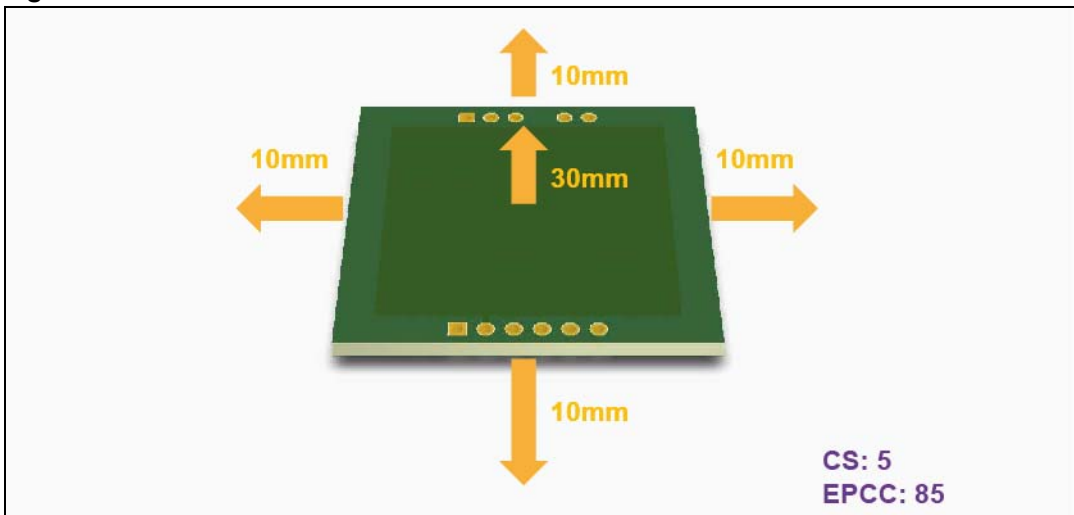


Figure 24. MB976 electrode board

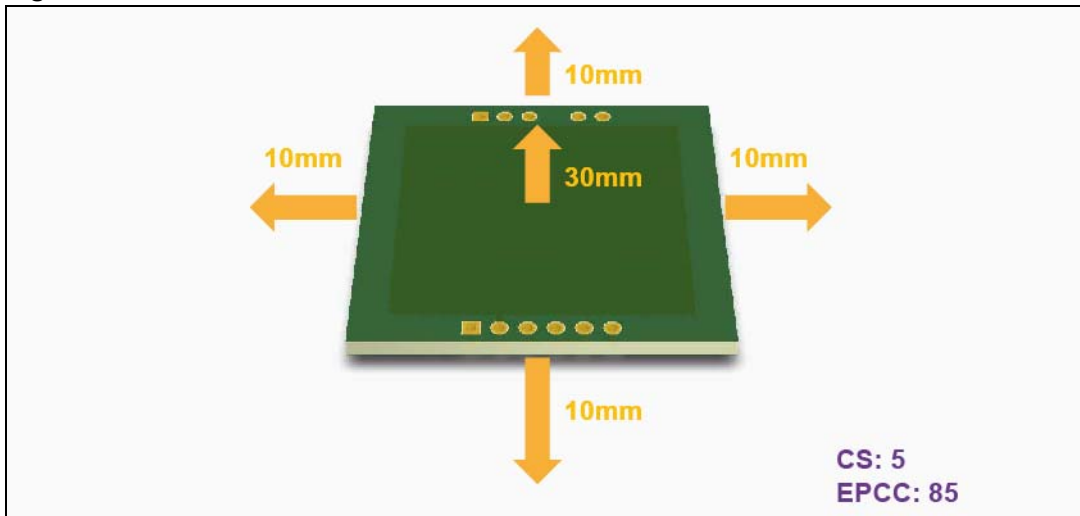


Figure 25. MB1022 electrode board

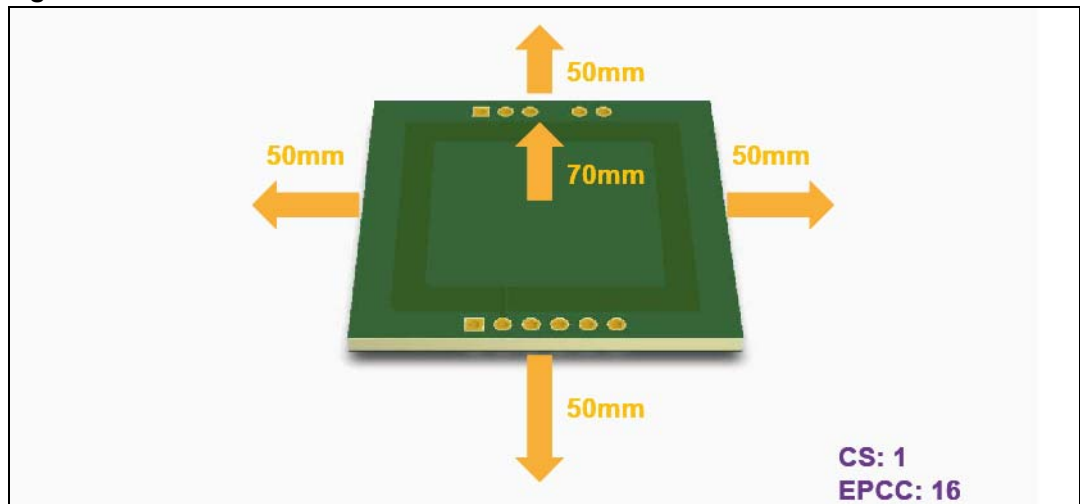
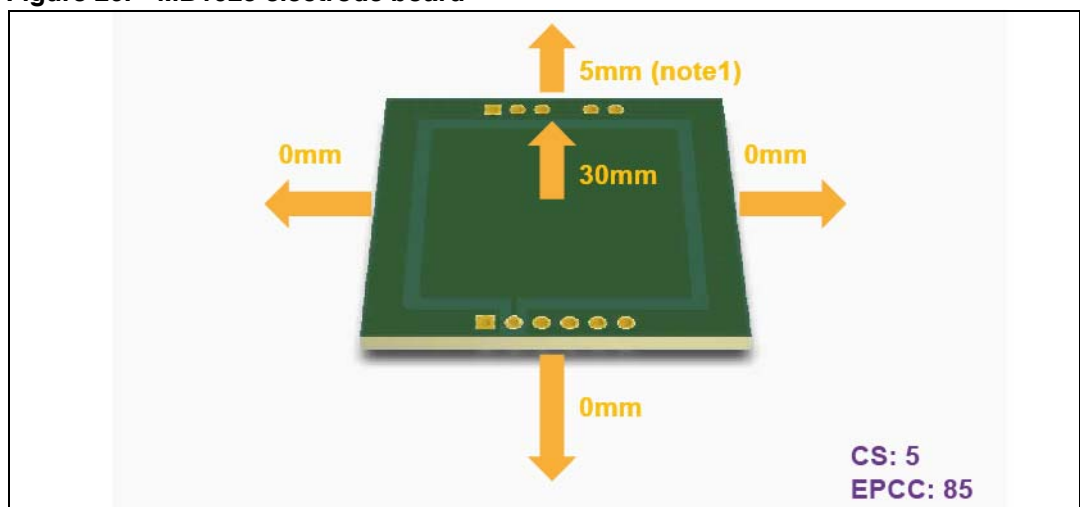


Figure 26. MB1025 electrode board



## 5 Troubleshooting

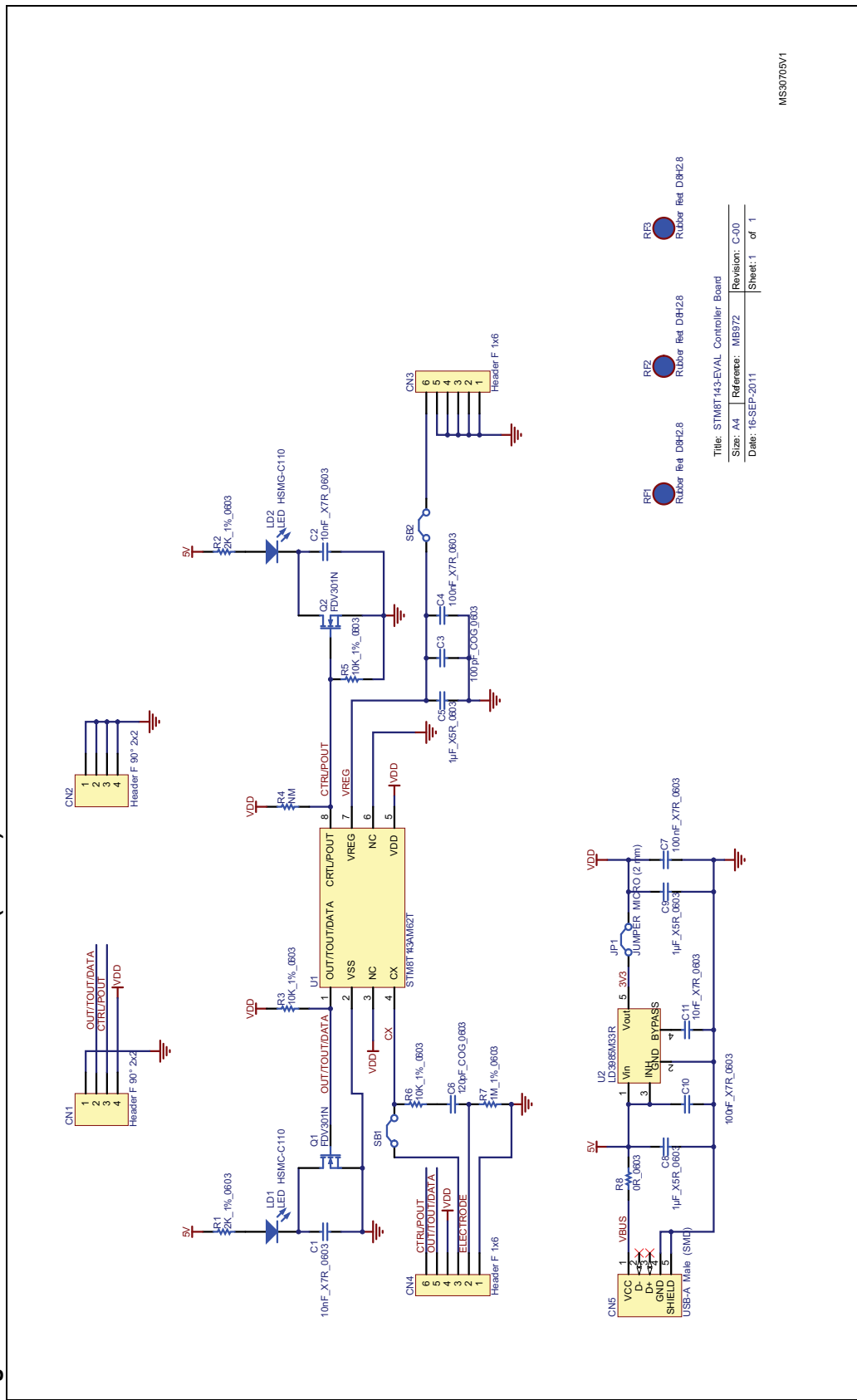
**Table 14. Troubleshooting**

Issue	Probable cause	Remedy
At device startup, the device sensitivity is low.	At power-up, the device calibration is performed with the hand close to the electrode.	<ul style="list-style-type: none"> <li>– Touch the electrode to force a dynamic calibration and remove quickly the hand from the electrode. Then the device will run with optimum performance.</li> <li>– Use a USB extension cable or a HUB to power the device. Then plug the cable extremity to avoid the hand proximity at startup.</li> </ul>
No device detected in data streaming mode.	Data streaming mode not activated	Set Data Streaming bit of option byte.
Device not supplied	IDD jumper not set	Set jumper JP1.

# 6 Board schematics

## 6.1 Controller board (MB972)

Figure 27. STM8T143-EVAL controller board (MB972)

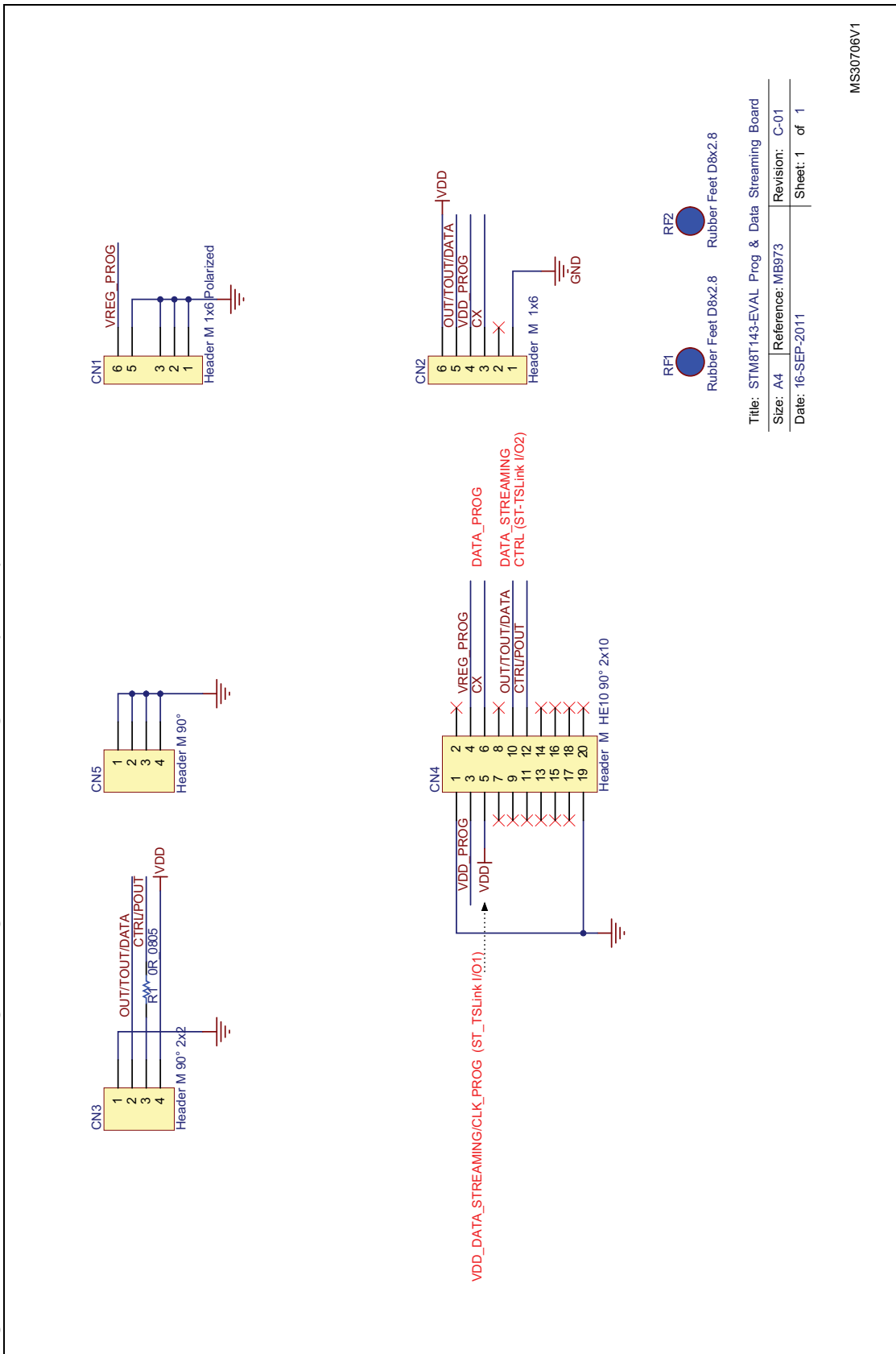


IMS30705V1



## 6.2 Programming and data streaming board (MB973)

Figure 28. STM8T143-EVAL Programming and data streaming board (MB973)



Title: STM8T143-EVAL Prog & Data Streaming Board  
 Size: A4 Reference: MB973 Revision: C-01  
 Date: 16-SEP-2011 Sheet: 1 of 1

MS30706V1



# Appendix A Board layout

## A.1 MB972 board layout

Figure 29. MB972 mechanical drawing

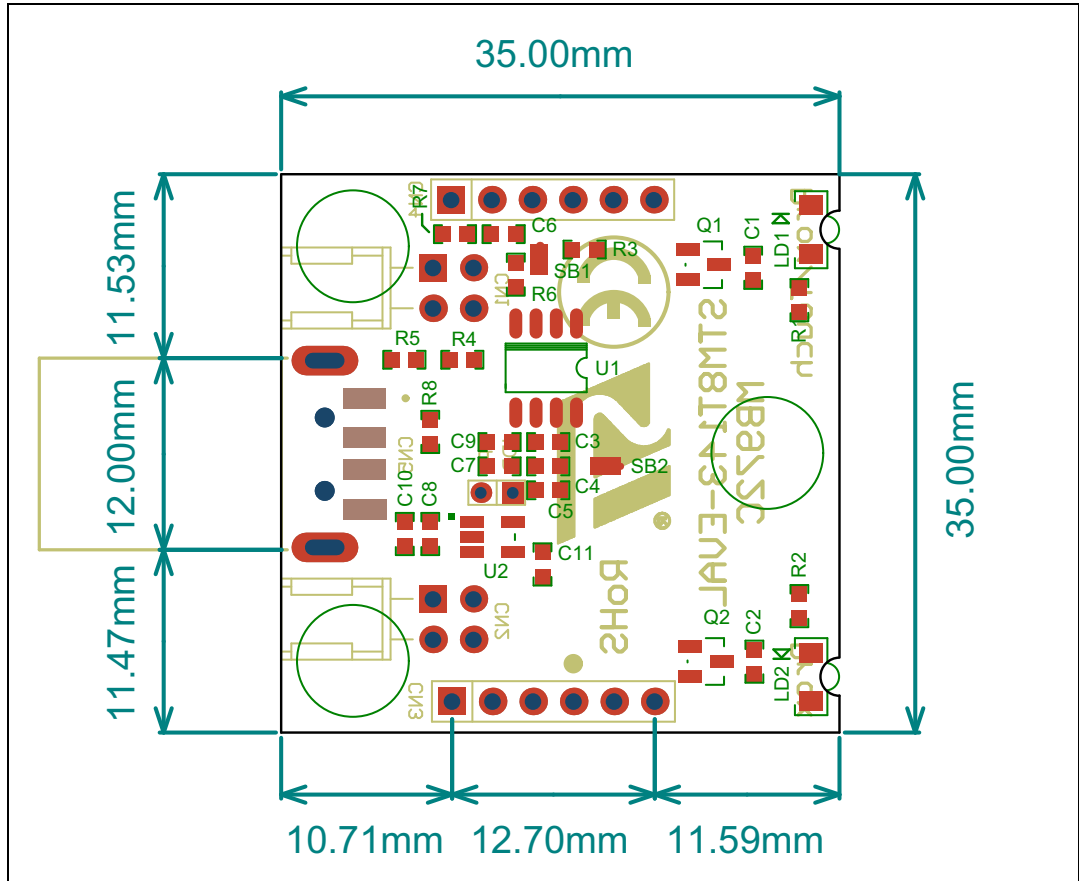


Figure 30. MB972 top silkscreen

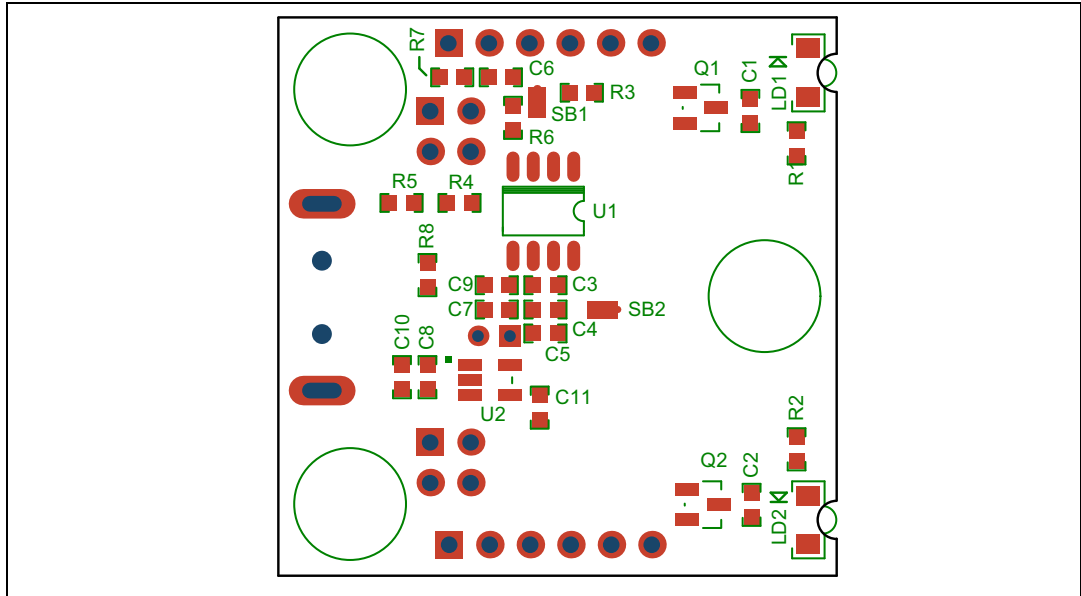
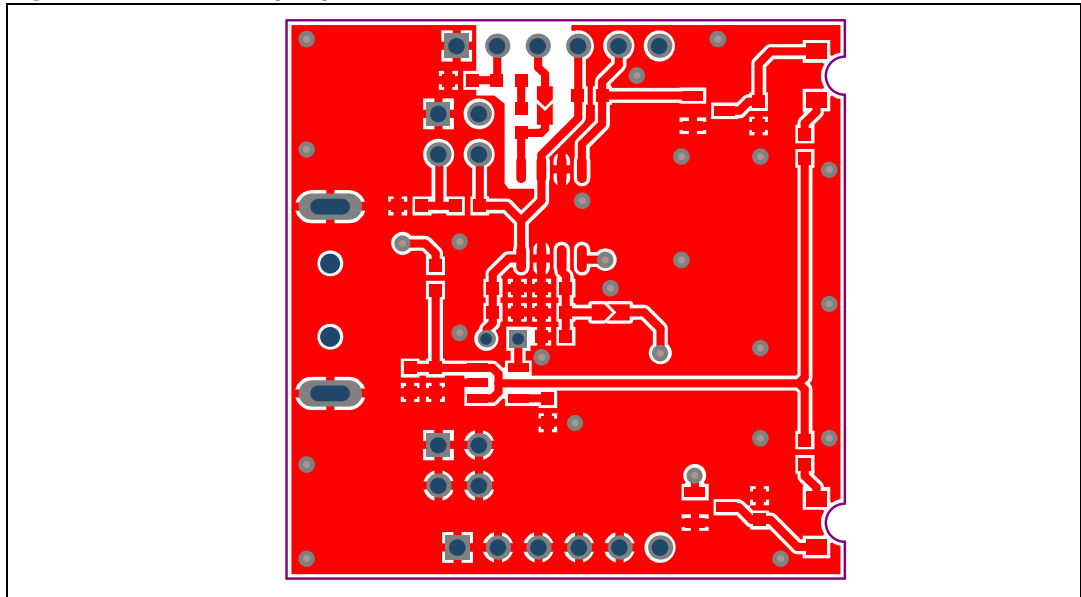


Figure 31. MB972 top layer



- 1. Pin 1 of CN1, CN2, CN3, CN4 connectors are identified by a square

Figure 32. MB972 bottom silkscreen

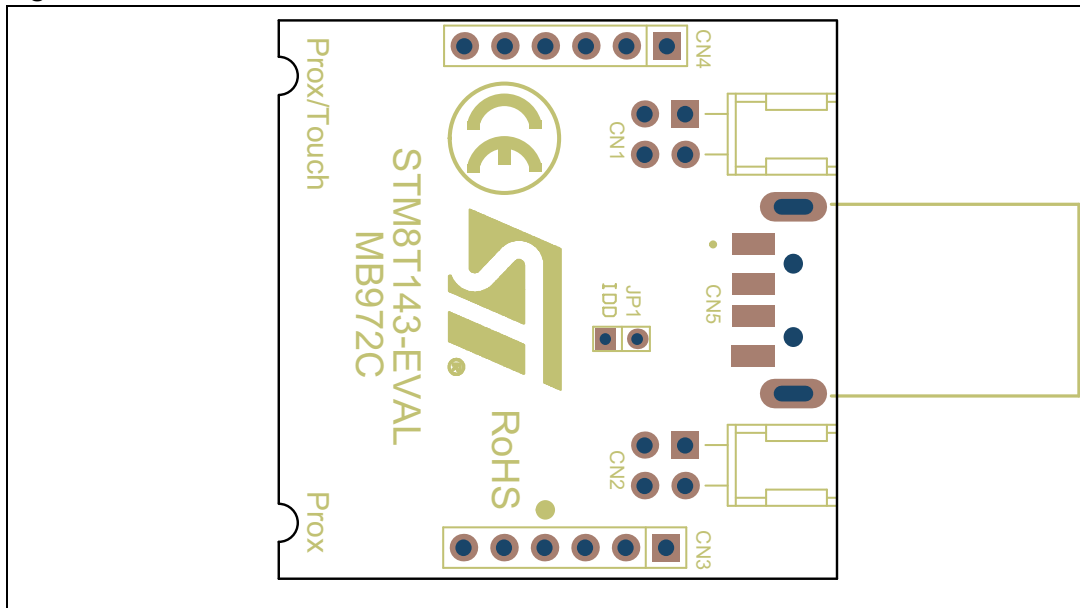
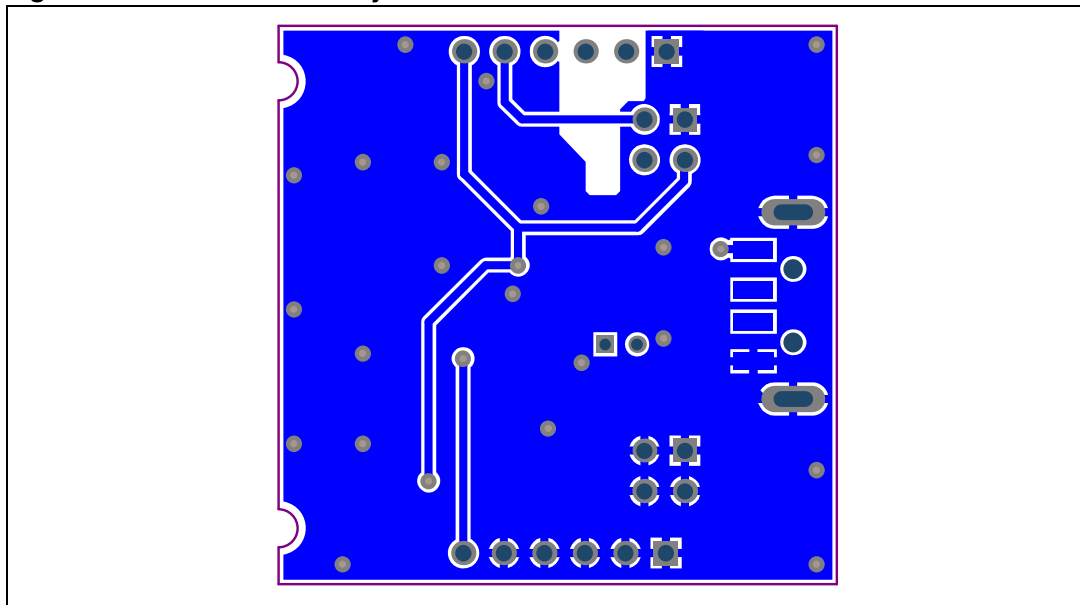


Figure 33. MB972 bottom layer



- 1. Pin 1 of CN1, CN2, CN3, CN4 connectors are identified by a square.

## A.2 MB973 board layout

Figure 34. MB973 mechanical drawing

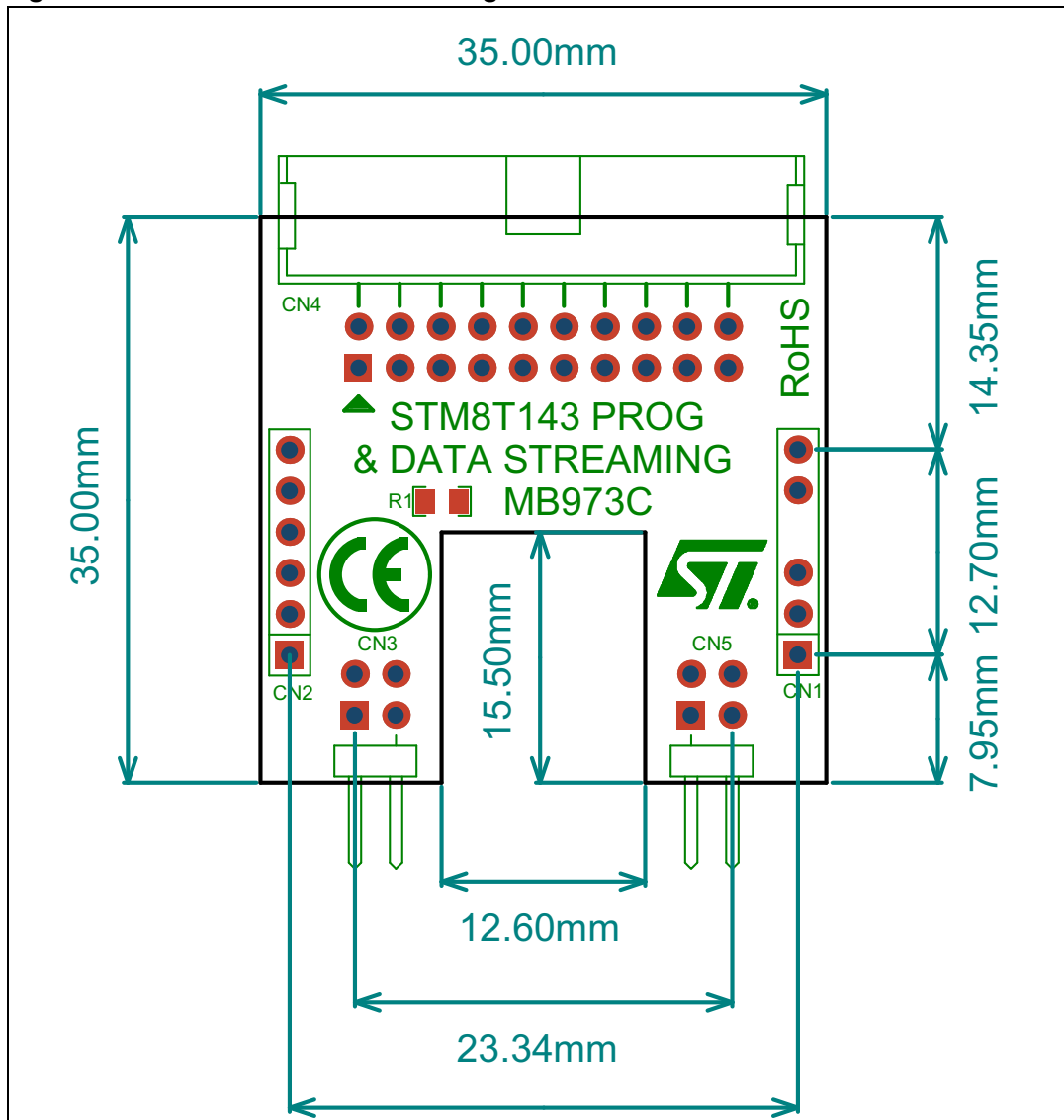


Figure 35. MB973 top silkscreen

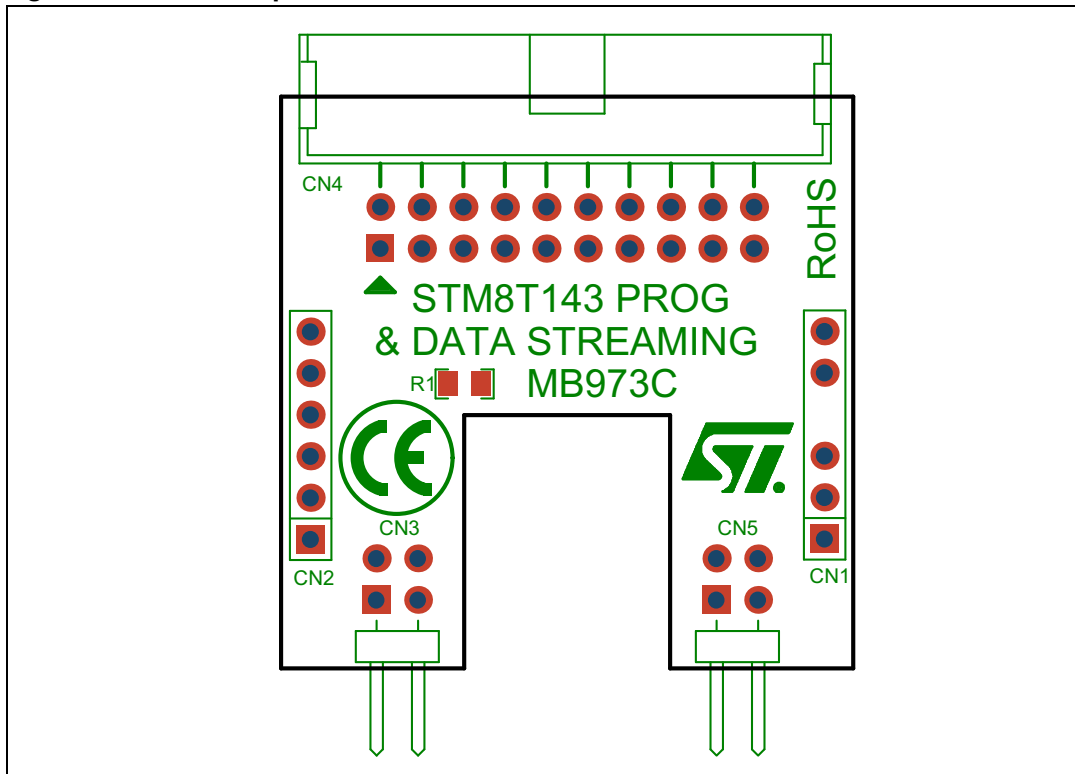
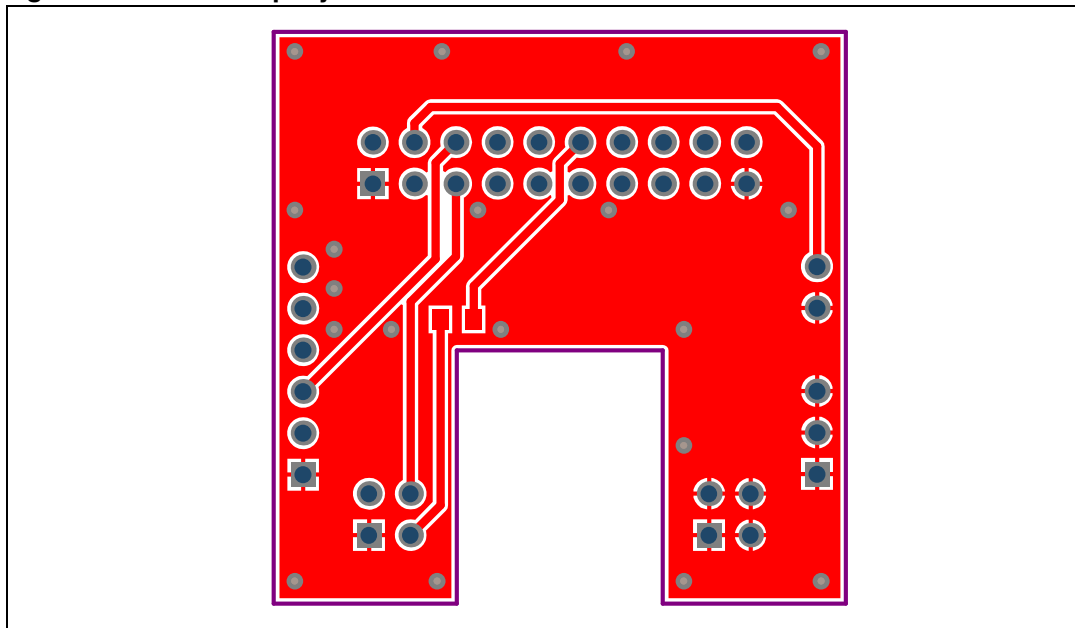


Figure 36. MB973 top layer



- 1. Pin 1 of CN1, CN2, CN3, CN4, CN5 connectors are identified by a square.

Figure 37. MB973 bottom silkscreen

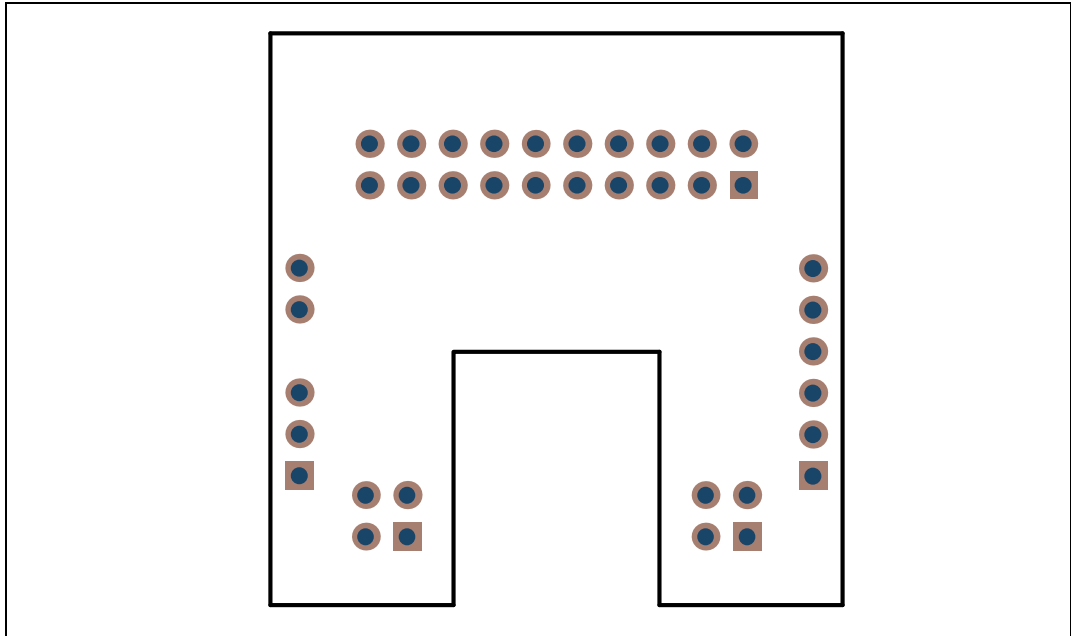
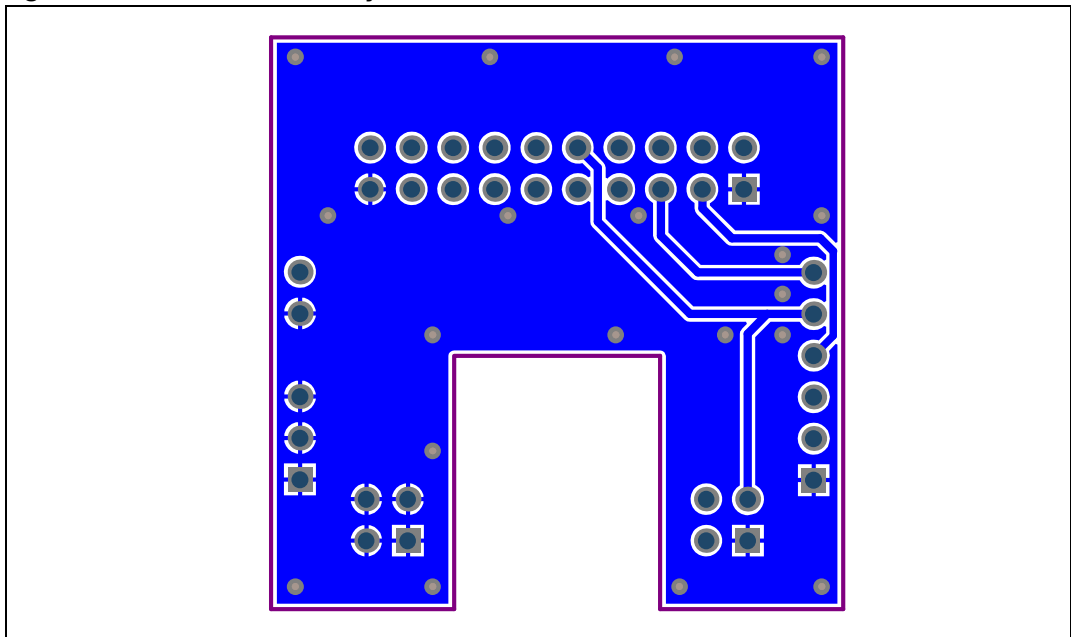


Figure 38. MB973 bottom layer



1. Pin 1 of CN1,CN2,CN3,CN4,CN5 connectors are identified by a square.

### A.3 Electrode board layouts

Figure 39. MB974 electrode board

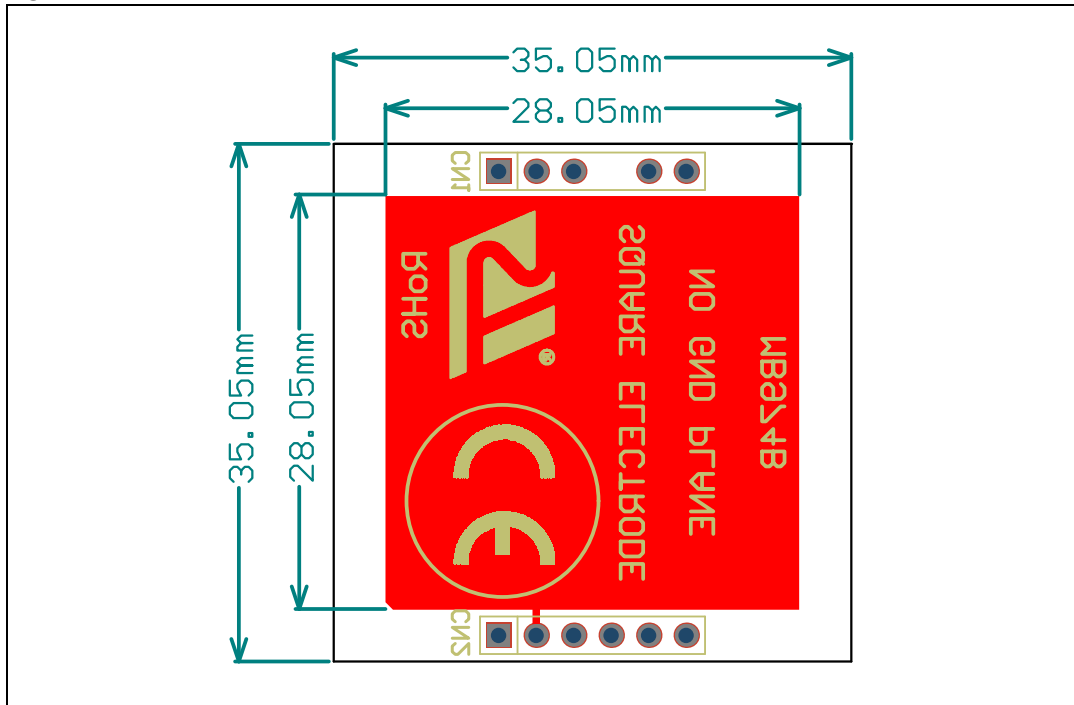


Figure 40. MB975 electrode board

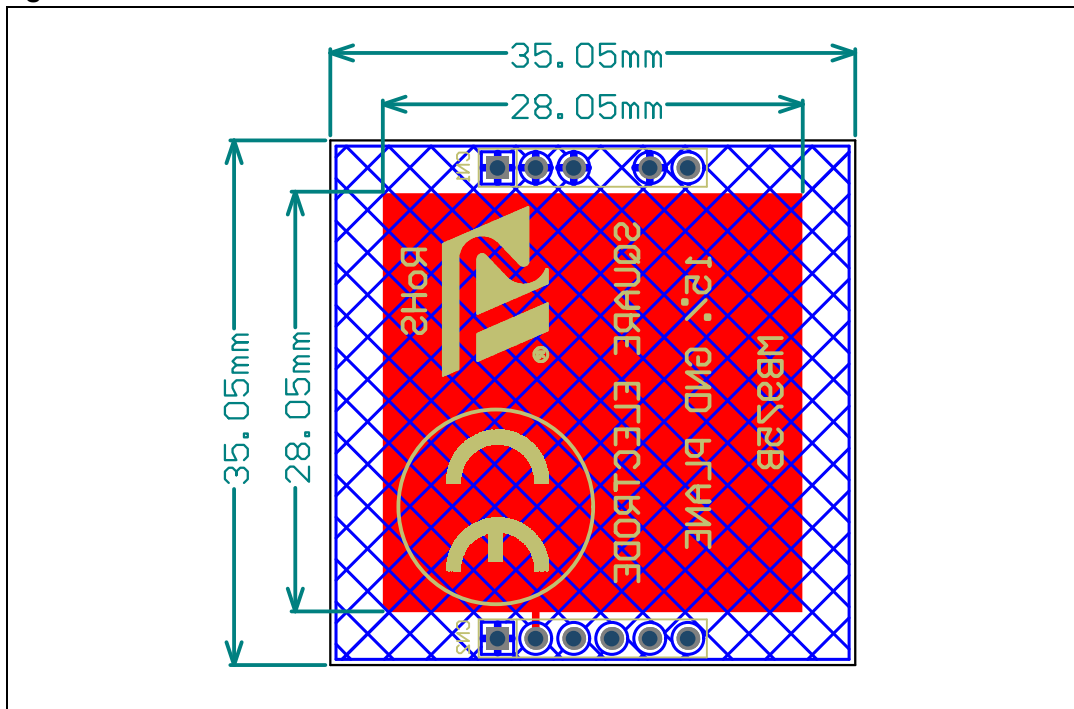


Figure 41. MB976 electrode board

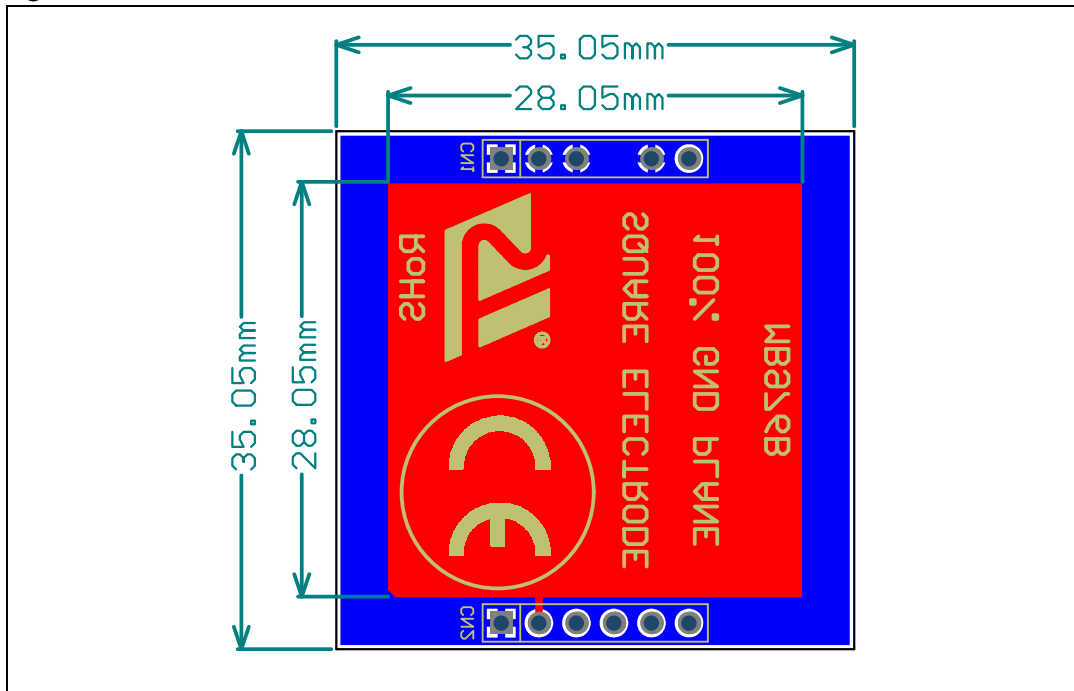


Figure 42. MB1022 electrode board

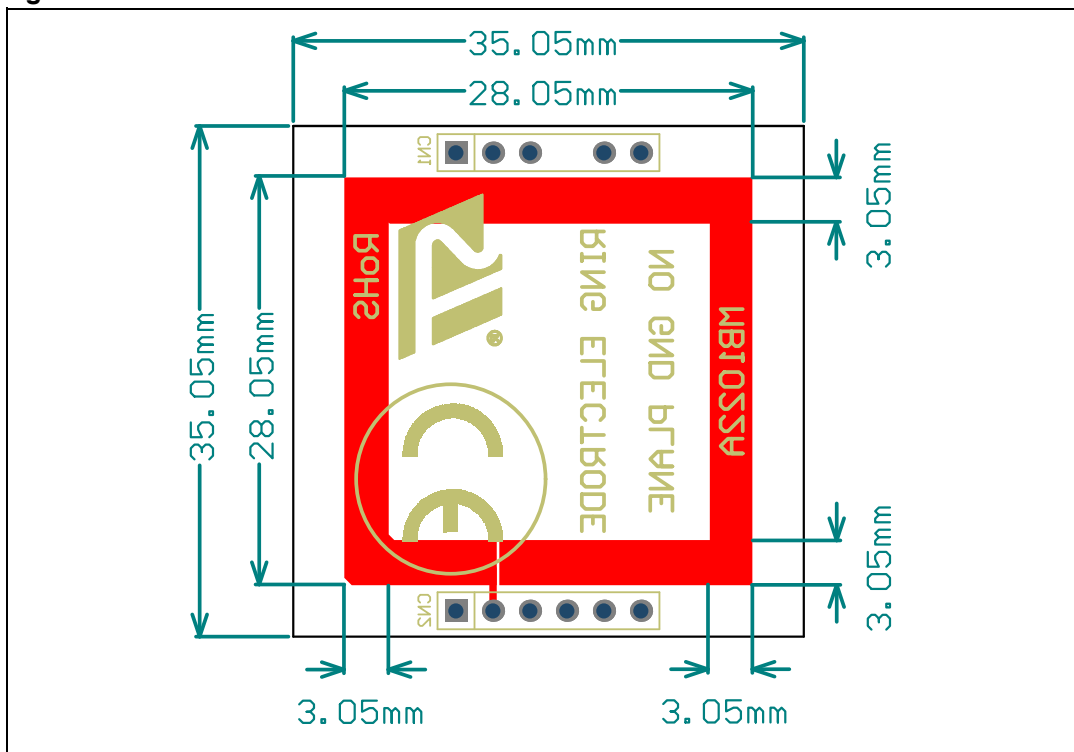
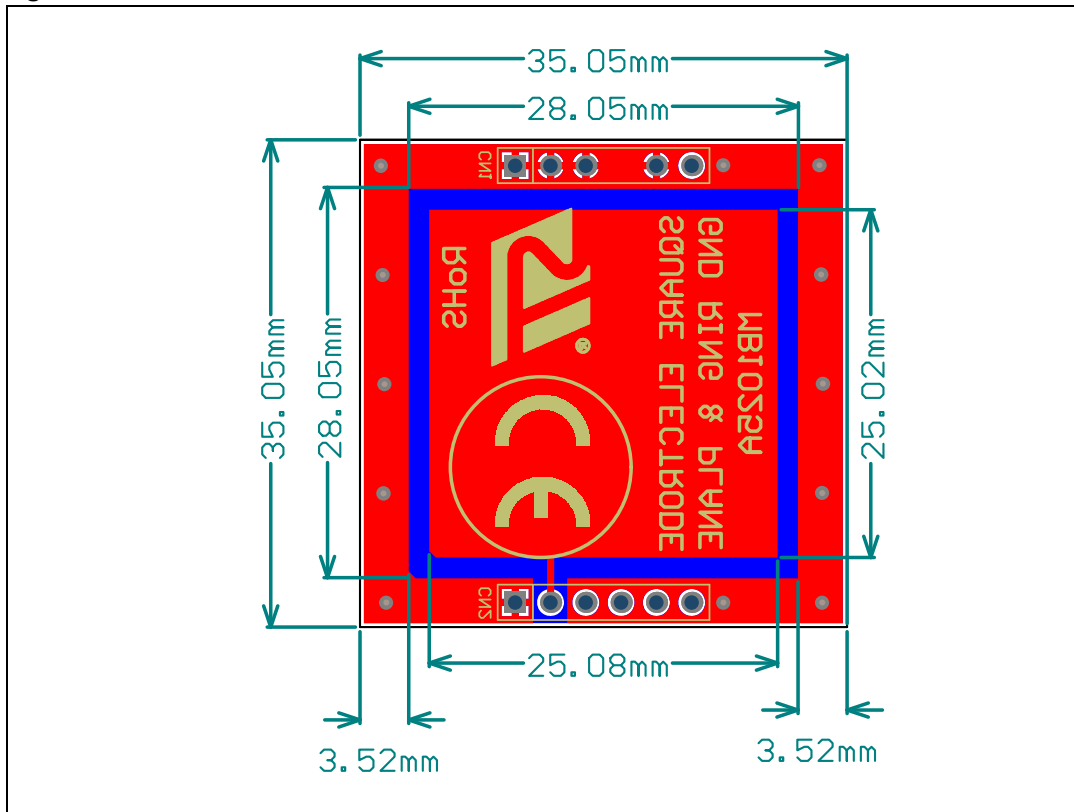


Figure 43. MB1025 electrode board



## Revision history

**Table 15. Document revision history**

Date	Revision	Changes
27-Aug-2012	1	Initial release.

**Please Read Carefully:**

Information in this document is provided solely in connection with ST products. STMicroelectronics NV and its subsidiaries ("ST") reserve the right to make changes, corrections, modifications or improvements, to this document, and the products and services described herein at any time, without notice.

All ST products are sold pursuant to ST's terms and conditions of sale.

Purchasers are solely responsible for the choice, selection and use of the ST products and services described herein, and ST assumes no liability whatsoever relating to the choice, selection or use of the ST products and services described herein.

No license, express or implied, by estoppel or otherwise, to any intellectual property rights is granted under this document. If any part of this document refers to any third party products or services it shall not be deemed a license grant by ST for the use of such third party products or services, or any intellectual property contained therein or considered as a warranty covering the use in any manner whatsoever of such third party products or services or any intellectual property contained therein.

**UNLESS OTHERWISE SET FORTH IN ST'S TERMS AND CONDITIONS OF SALE ST DISCLAIMS ANY EXPRESS OR IMPLIED WARRANTY WITH RESPECT TO THE USE AND/OR SALE OF ST PRODUCTS INCLUDING WITHOUT LIMITATION IMPLIED WARRANTIES OF MERCHANTABILITY, FITNESS FOR A PARTICULAR PURPOSE (AND THEIR EQUIVALENTS UNDER THE LAWS OF ANY JURISDICTION), OR INFRINGEMENT OF ANY PATENT, COPYRIGHT OR OTHER INTELLECTUAL PROPERTY RIGHT.**

**UNLESS EXPRESSLY APPROVED IN WRITING BY TWO AUTHORIZED ST REPRESENTATIVES, ST PRODUCTS ARE NOT RECOMMENDED, AUTHORIZED OR WARRANTED FOR USE IN MILITARY, AIR CRAFT, SPACE, LIFE SAVING, OR LIFE SUSTAINING APPLICATIONS, NOR IN PRODUCTS OR SYSTEMS WHERE FAILURE OR MALFUNCTION MAY RESULT IN PERSONAL INJURY, DEATH, OR SEVERE PROPERTY OR ENVIRONMENTAL DAMAGE. ST PRODUCTS WHICH ARE NOT SPECIFIED AS "AUTOMOTIVE GRADE" MAY ONLY BE USED IN AUTOMOTIVE APPLICATIONS AT USER'S OWN RISK.**

Resale of ST products with provisions different from the statements and/or technical features set forth in this document shall immediately void any warranty granted by ST for the ST product or service described herein and shall not create or extend in any manner whatsoever, any liability of ST.

ST and the ST logo are trademarks or registered trademarks of ST in various countries.

Information in this document supersedes and replaces all information previously supplied.

The ST logo is a registered trademark of STMicroelectronics. All other names are the property of their respective owners.

© 2012 STMicroelectronics - All rights reserved

STMicroelectronics group of companies

Australia - Belgium - Brazil - Canada - China - Czech Republic - Finland - France - Germany - Hong Kong - India - Israel - Italy - Japan - Malaysia - Malta - Morocco - Philippines - Singapore - Spain - Sweden - Switzerland - United Kingdom - United States of America

[www.st.com](http://www.st.com)



## Looking for pricing, stock, or lifecycle information?

Click below to explore more details on WIN SOURCE:

- ⊖ [View STM8T143-EVAL](#) on WIN SOURCE
- ⊖ [STMicroelectronics](#) Information

## Optimize Your Supply Chain with WIN SOURCE Solutions

- ✓ Global Sourcing Solution
- ✓ Obsolete Management
- ✓ Cost Control Management
- ✓ Shortage Management
- ✓ Alternative Solution
- ✓ Excess Inventory Management