



**THE DATASHEET OF
STK534U362C-E**



ON Semiconductor

Is Now

onsemi™

To learn more about onsemi™, please visit our website at
www.onsemi.com

onsemi and **onsemi** and other names, marks, and brands are registered and/or common law trademarks of Semiconductor Components Industries, LLC dba "**onsemi**" or its affiliates and/or subsidiaries in the United States and/or other countries. **onsemi** owns the rights to a number of patents, trademarks, copyrights, trade secrets, and other intellectual property. A listing of **onsemi** product/patent coverage may be accessed at www.onsemi.com/site/pdf/Patent-Marking.pdf. **onsemi** reserves the right to make changes at any time to any products or information herein, without notice. The information herein is provided "as-is" and **onsemi** makes no warranty, representation or guarantee regarding the accuracy of the information, product features, availability, functionality, or suitability of its products for any particular purpose, nor does **onsemi** assume any liability arising out of the application or use of any product or circuit, and specifically disclaims any and all liability, including without limitation special, consequential or incidental damages. Buyer is responsible for its products and applications using **onsemi** products, including compliance with all laws, regulations and safety requirements or standards, regardless of any support or applications information provided by **onsemi**. "Typical" parameters which may be provided in **onsemi** data sheets and/or specifications can and do vary in different applications and actual performance may vary over time. All operating parameters, including "Typicals" must be validated for each customer application by customer's technical experts. **onsemi** does not convey any license under any of its intellectual property rights nor the rights of others. **onsemi** products are not designed, intended, or authorized for use as a critical component in life support systems or any FDA Class 3 medical devices or medical devices with a same or similar classification in a foreign jurisdiction or any devices intended for implantation in the human body. Should Buyer purchase or use **onsemi** products for any such unintended or unauthorized application, Buyer shall indemnify and hold **onsemi** and its officers, employees, subsidiaries, affiliates, and distributors harmless against all claims, costs, damages, and expenses, and reasonable attorney fees arising out of, directly or indirectly, any claim of personal injury or death associated with such unintended or unauthorized use, even if such claim alleges that **onsemi** was negligent regarding the design or manufacture of the part. **onsemi** is an Equal Opportunity/Affirmative Action Employer. This literature is subject to all applicable copyright laws and is not for resale in any manner. Other names and brands may be claimed as the property of others.

STK534U362C-E

Intelligent Power Module (IPM) 600 V, 10 A



ON Semiconductor®

www.onsemi.com

Overview

This “Inverter IPM” is highly integrated device containing all High Voltage (HV) control from HV-DC to 3-phase outputs in a single SIP module (Single-In line Package). Output stage uses IGBT/FRD technology and implements Under Voltage Protection (UVP). Internal Boost diodes are provided for high side gate boost drive.

Function

- Single control power supply due to Internal bootstrap circuit for high side pre-driver circuit
- All control input and status output are at low voltage levels directly compatible with microcontrollers.
- Built-in cross conduction prevention.
- Externally accessible embedded thermistor for substrate temperature measurement

Certification

- UL1557 (File number: E339285)

Specifications

Absolute Maximum Ratings at Tc = 25°C

Parameter	Symbol	Remarks	Ratings	Unit
Supply voltage	V _{CC}	P to U-, V-, W-, surge < 500 V *1	450	V
Collector-emitter voltage	V _{CE}	P to U, V, W or U, V, W, to U-, V-, W-	600	V
Output current	I _o	P,U-,V-,W-,U,V,W terminal current	±10	A
		P,U-,V-,W-,U,V,W terminal current, Tc = 100°C	±5	A
Output peak current	I _{op}	P,U-,V-,W-,U,V,W terminal current, P.W. = 1 ms	±20	A
Pre-driver voltage	VD1,2,3,4	VB1 to U, VB2 to V, VB3 to W, V _{DD} to V _{SS} *2	20	V
Input signal voltage	V _{IN}	HIN1, 2, 3, LIN1, 2, 3	-0.3 to V _{DD}	V
FLTEN terminal voltage	V _{FLTEN}	FLTEN terminal	-0.3 to V _{DD}	V
Maximum power dissipation	P _d	IGBT per 1 channel	31.2	W
Junction temperature	T _j	IGBT, FRD, Pre-Driver IC	150	°C
Storage temperature	T _{stg}		-40 to +125	°C
Operating case temperature	T _c	IPM case	-20 to +100	°C
Tightening torque		A screw part *3	0.9	Nm
Withstand voltage	V _{is}	50 Hz sine wave AC 1 minute *4	2000	VRMS

Reference voltage is “V_{SS}” terminal voltage unless otherwise specified.

*1: Surge voltage developed by the switching operation due to the wiring inductance between P and U-(V-, W-) terminal.

*2: Terminal voltage: VD1 = VB1 to U, VD2 = VB2 to V, VD3 = VB3 to W, VD4 = V_{DD} to V_{SS}.

*3: Flatness of the heat-sink should be 0.15 mm and below.

*4: Test conditions : AC 2500 V, 1 s.

Stresses exceeding those listed in the Maximum Ratings table may damage the device. If any of these limits are exceeded, device functionality should not be assumed, damage may occur and reliability may be affected.

ORDERING INFORMATION

See detailed ordering and shipping information on page 15 of this data sheet.

STK534U362C-E

Electrical Characteristics at Tc = 25°C, VD1, VD2, VD3, VD4 = 15 V

Parameter	Symbol	Conditions	Test circuit	MIN	TYP	MAX	Unit
Power output section							
Collector-emitter cut-off current	ICE	VCE = 600 V	Fig.1	-	-	100	μA
Bootstrap diode reverse current	IR(BD)	VR(BD) = 600 V		-	-	100	μA
Collector to emitter saturation voltage	VCE(SAT)	Ic = 10 A, Tj=25°C	Fig.2	-	1.6	2.4	V
		Ic = 5 A, Tj=100°C		-	1.4	-	
Diode forward voltage	VF	IF = 10 A, Tj=25°C	Fig.3	-	1.4	2.1	V
		IF = 5 A, Tj=100°C		-	1.2	-	
Junction to case thermal resistance	θj-c(T)	IGBT	-	-	-	4	°C/W
	θj-c(D)	FWD		-	-	6	
Control (Pre-driver) section							
Pre-driver power dissipation	ID	VD1,2,3 = 15 V	Fig.4	-	0.08	0.4	mA
		VD4 = 15 V		-	1.6	4	
High level Input voltage	Vin H	HIN1,HIN2,HIN3,	-	2.5	-	-	V
Low level Input voltage	Vin L	LIN1,LIN2,LIN3 to VSS	-	-	-	0.8	V
Logic 1 input leakage current	IIN+	VIN = +3.3 V	-	-	100	143	μA
Logic 0 input leakage current	IIN-	VIN = 0 V	-	-	-	2	μA
FLTEN terminal sink current	IoSD	FAULT:ON / VFLTEN=0.1V	-	-	2	-	mA
FLTEN clearance delay time	FLTCLR	From time fault condition clear	-	1.0	2.0	3.0	ms
FLTEN Threshold	VEN+	VEN rising	-	-	-	2.5	V
	VEN-	VEN falling	-	0.8	-	-	V
ITRIP threshold voltage	VITRIP	ITRIP(16) to VSS(29)	-	0.44	0.49	0.54	V
ITRIP to shutdown propagation delay	tITRIP		-	340	550	800	ns
ITRIP blanking time	tITRIPBL		-	250	350	-	ns
VCC and VBS supply undervoltage protection reset	VCCUV+		-	10.5	11.1	11.7	V
	VBSUV+						
VCC and VBS supply undervoltage protection set	VCCUV-		-	10.3	10.9	11.5	V
	VBSUV-						
VCC and VBS supply undervoltage hysteresis	VCCUVH		-	0.14	0.2	-	V
	VBSUVH						

Reference voltage is "VSS" terminal voltage unless otherwise specified.

Product parametric performance is indicated in the Electrical Characteristics for the listed test conditions, unless otherwise noted. Product performance may not be indicated by the Electrical Characteristics if operated under different conditions.

STK534U362C-E

Electrical Characteristics at $T_c = 25^\circ\text{C}$, $V_{D1}, V_{D2}, V_{D3}, V_{D4} = 15\text{ V}$, $V_{CC} = 300\text{ V}$, $L = 3.9\text{ mH}$

Parameter	Symbol	Conditions	Test circuit	MIN	TYP	MAX	Unit
Switching Character							
Switching time	t ON	$I_o = 10\text{ A}$	Fig.5	0.3	0.5	1.2	μs
	t OFF			-	1.5	2.0	
Turn-on switching loss	Eon	$I_o = 5\text{ A}$	Fig.5	-	240	-	μJ
Turn-off switching loss	Eoff			-	120	-	μJ
Total switching loss	Etot			-	360	-	μJ
Turn-on switching loss	Eon	$I_o = 5\text{ A}, T_c = 100^\circ\text{C}$	Fig.5	-	270	-	μJ
Turn-off switching loss	Eoff			-	160	-	μJ
Total switching loss	Etot			-	430	-	μJ
Diode reverse recovery energy	Erec	$I_F = 5\text{ A}, P = 400\text{ V}, L = 0.5\text{ mH},$	-	-	17	-	μJ
Diode reverse recovery time	Trr	$T_c = 100^\circ\text{C}$	-	-	62	-	ns
Reverse bias safe operating area	RBSOA	$I_o = 20\text{ A}, V_{CE} = 450\text{ V}$	-	Full square-			
Short circuit safe operating area	SCSOA	$V_{CE} = 400\text{ V}, T_c = 100^\circ\text{C}$	-	4	-	-	μs
Allowable offset voltage slew rate	dv/dt	Between U,V,W to U-,V-,W-	-	-50	-	50	V/ns

Reference voltage is "VSS" terminal voltage unless otherwise specified.

Product parametric performance is indicated in the Electrical Characteristics for the listed test conditions, unless otherwise noted. Product performance may not be indicated by the Electrical Characteristics if operated under different conditions.

Notes

- When the internal protection circuit operates, a Fault signal is turned ON (When the Fault terminal is low level, Fault signal is ON state : output form is open DRAIN) but the Fault signal does not latch. After protection operation ends, it returns automatically within about typ. 2 ms and resumes operation beginning condition. So, after Fault signal detection, set all input signals to OFF (Low) at once. However, the operation of pre-drive power supply low voltage protection (UVLO: with hysteresis about 0.2 V) is as follows.

Upper side:

The gate is turned off and will return to regular operation when recovering to the normal voltage, but the latch will continue till the input signal will turn 'low'.

Lower side:

The gate is turned off and will automatically reset when recovering to normal voltage. It does not depend on input signal voltage.

- When assembling the IPM on the heat sink with M3 type screw, tightening torque range is 0.6 Nm to 0.9 Nm.
- When use the over-current protection with external resistor, please set resistance value so that current protection value becomes equal to or less than the double (2 times) of the rating output electric current (I_o).

Equivalent Block Diagram

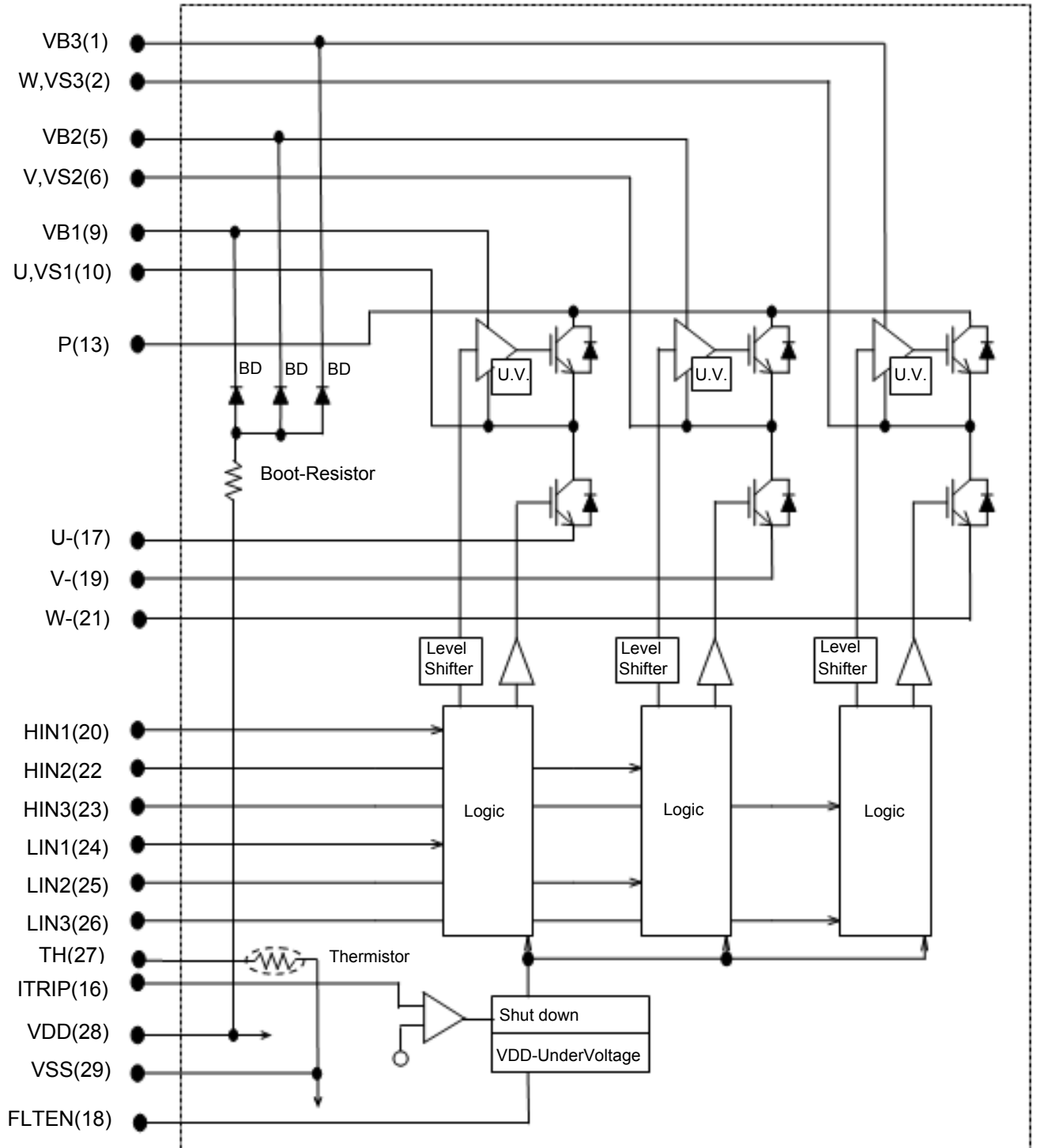

Test Circuit

(The tested phase : U+ shows the upper side of the U phase and U- shows the lower side of the U phase.)

■ ICE / IR(BD)

	U+	V+	W+	U-	V-	W-
M	13	13	13	10	6	2
N	10	6	2	17	19	21

	U(BD)	V(BD)	W(BD)
M	9	5	1
N	29	29	29

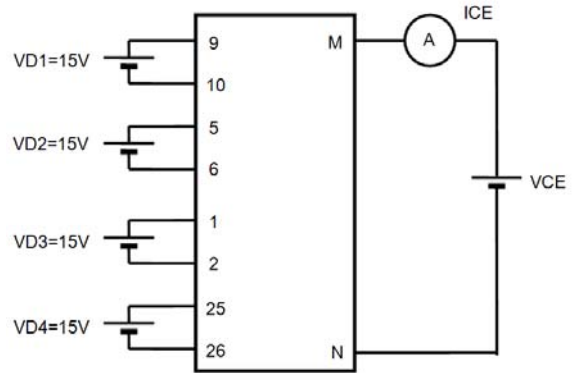

Fig.1

■ VCE(SAT) (Test by pulse)

	U+	V+	W+	U-	V-	W-
M	13	13	13	10	6	2
N	10	6	2	17	19	21
m	20	22	23	24	25	26

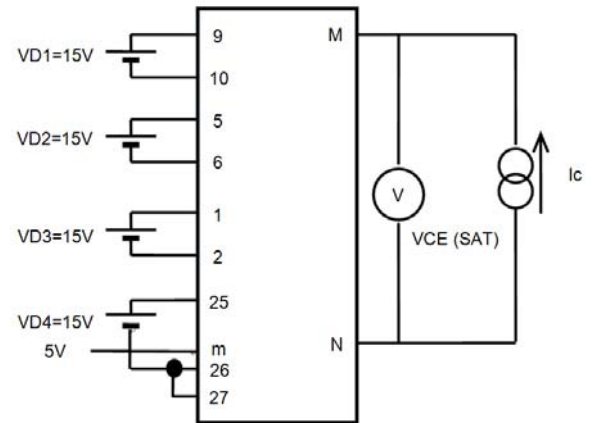

Fig.2

■ VF (Test by pulse)

	U+	V+	W+	U-	V-	W-
M	13	13	13	10	6	2
N	10	6	2	17	19	21

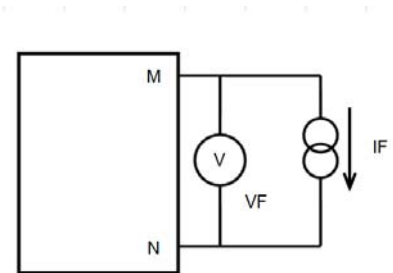

Fig.3

■ ID

	VD1	VD2	VD3	VD4
M	9	5	1	28
N	10	6	2	29

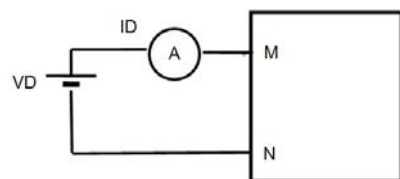

Fig.4

■ Switching time (The circuit is a representative example of the lower side U phase.)

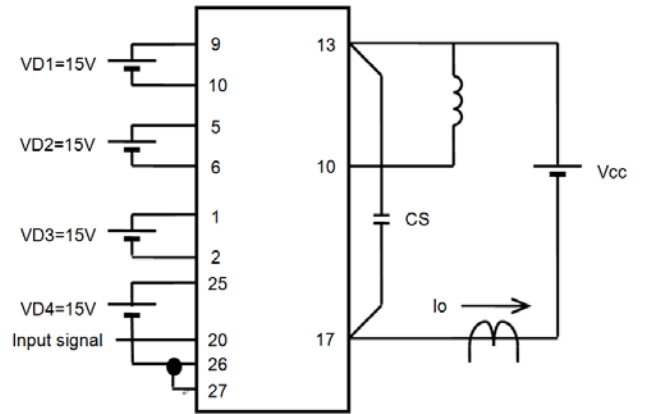
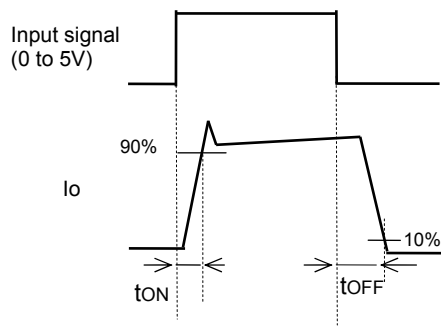

Fig.5

Input / Output Timing Chart

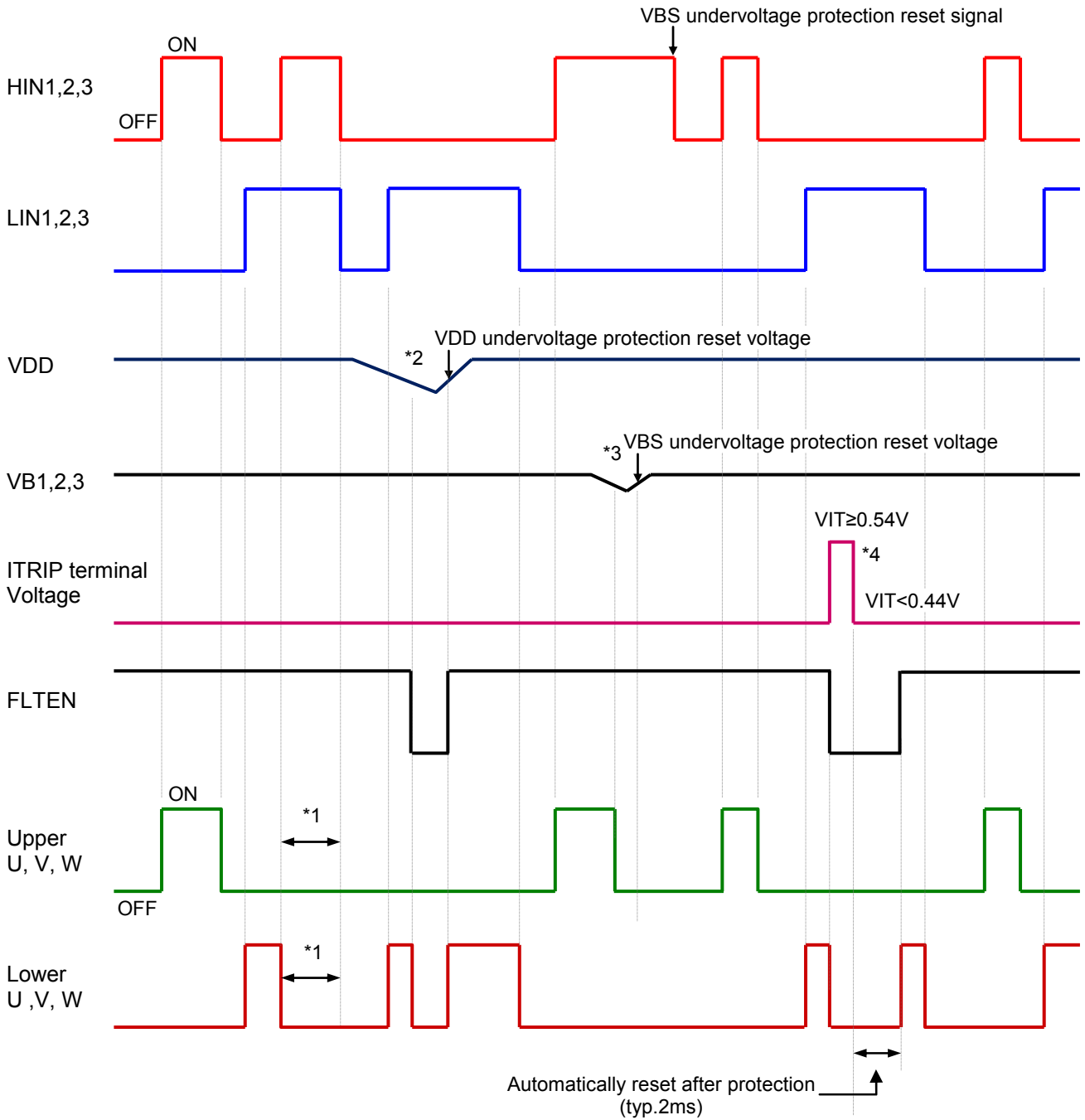

Fig. 7

Notes

- *1 shows the prevention of shoot-thru via control logic, however, more dead time must be added to account for switching delay externally.
- *2 when V_{DD} decreases all gate output signals will go low and cut off all 6 IGBT outputs. When V_{DD} rises the operation will resume immediately.
- *3 when the upper side voltage at VB1, VB2 and VB3 drops only the corresponding upper side output is turned off. The outputs return to normal operation immediately after the upper side gate voltage rises.
- *4 when V_{ITRIP} exceeds threshold all IGBT's are turned off and normal operation resumes 2ms (typ) after over current condition is removed.

STK534U362C-E

Logic level table

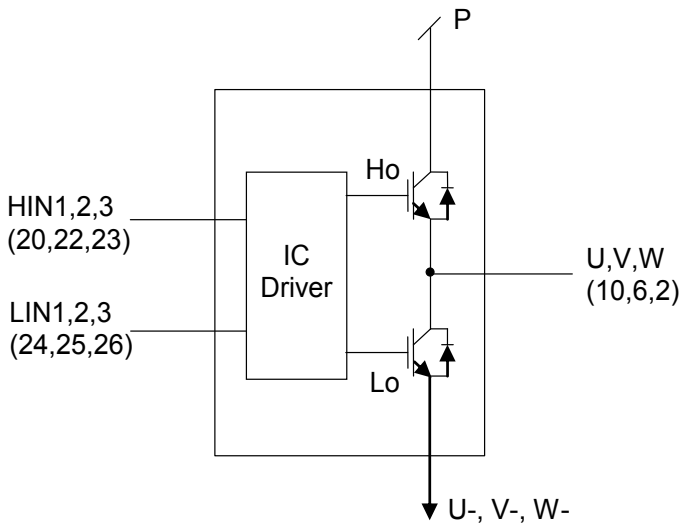

INPUT			OUTPUT			
HIN	LIN	Itrip	Ho	Lo	U,V,W	FLTEN
H	L	L	H	L	P	OFF
L	H	L	L	H	U-,V-,W-	OFF
L	L	L	L	L	High Impedance	OFF
H	H	L	L	L	High Impedance	OFF
X	X	H	L	L	High Impedance	ON

Fig. 8

Sample Application Circuit

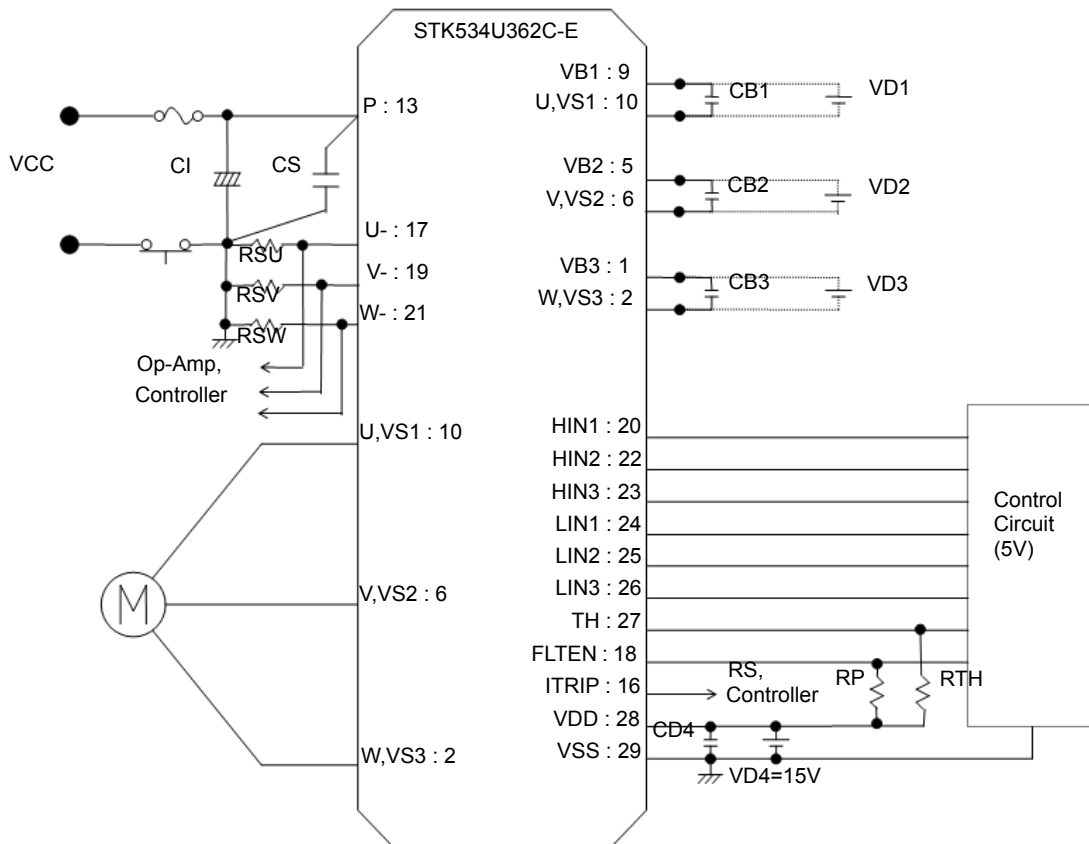

Fig.9

STK534U362C-E

Recommended Operating Condition at Tc = 25°C

Item	Symbol	Conditions	Min.	Typ.	Max.	Unit
Supply voltage	V _{CC}	+ to U-(V-,W-)	0	280	450	V
Pre-driver supply voltage	VD1,2,3	VB1 to U,VB2 to V,VB3 to W	12.5	15	17.5	V
	VD4	V _{DD} to V _{SS} *1	13.5	15	16.5	
ON-state input voltage	V _{IN} (ON)	HIN1,HIN2,HIN3,	3.0	-	5.0	V
OFF-state input voltage	V _{IN} (OFF)	LIN1,LIN2,LIN3				
PWM frequency	fPWM		1	-	20	kHz
Dead time	DT	Turn-off to turn-on (external)	2.5	-	-	μs
Allowable input pulse width	PWIN	ON and OFF	1	-	-	μs
Mounting torque		'M3' type screw	0.6	-	0.9	Nm

*1 Pre-drive power supply (VD4 = 15 ±1.5 V) must be have the capacity of I_o = 20 mA (DC), 0.5 A (Peak).

Functional operation above the stresses listed in the Recommended Operating Ranges is not implied. Extended exposure to stresses beyond the Recommended Operating Ranges limits may affect device reliability.

Usage Precaution

1. This IPM includes bootstrap diode and resistor. Therefore, by adding a capacitor (CB : about 1 to 47 μF), a single power supply drive is enabled. In this case, an electric charge is charged to "CB" by making lower side IGBT turn on.
And, please select the capacitance of "CB"(externally set) equal to or less than 47 μF ($\pm 20\%$).If selecting the capacitance more than 47 μF ($\pm 20\%$), connect a resistor (about 20 Ω) in series between each 3-phase upper side power supply terminals (VB1,2,3) and each bootstrap capacitor. Also, the upper side power supply voltage sometimes declines by the way of controlling. Please confirm the voltage with an actual set.
(When not using the bootstrap circuit, each upper side pre-drive power supply needs an external independent power supply.)
 2. Because the jump voltage which is accompanied by the vibration in case of switching operation occurs by the influence of the floating inductance of the wiring of the outer power supply which is connected with of the "+" terminal and the "U-"("V-", "W-") terminal, restrains and spares surge voltage being as the connection of the snubber circuit (Capacitor / CS /about 0.1 μF to 10 μF) for the voltage absorption with the neighborhood as possible between the "+" and the point of intersection of the "U-", "V-" and "W-" terminal, and so on, with making a wiring length (among the terminals each from "CI") short and making a wiring inductance small.
 3. The "FLTEN" terminal (18 pin) is open Drain (It is operating as "FLTEN" when becoming Low). This terminal serves as the shut down function of the built-in pre-driver. (When the terminal voltage is above 3V,normalcy works, and it is shut down when it is equal to or less than 0.8 V.)Please make pulling up outside so that "FLTEN" terminal voltages become more than 3 V. When the pull up voltage (VP) is at 5 V, pull up resistor (RP) connects above 6.8 k Ω , and in case of VP = 15 V, RP connects above 20 k Ω .
 4. Inside the IPM, thermistor is connected to between the "TH" terminal (27 pin) and the "VSS" terminal (29 pin). The thermistor can be used as the temperature monitor by pull up with the resistance (Rth). (This is for temperature monitors, and it is not a thing having the hyper temperature protection function by IPM oneself). This is for temperature monitors of substrate in the steady movement state. Therefore, please take care of the suddenly and partial fever.
 5. The pull-down resistor (: 33 k Ω (typ)) is connected with the inside of the signal input terminal, but please connect the pull-down resistor(about 2.2 to 3.3 k Ω) outside to decrease the influence of the noise by wiring etc.
 6. The overcurrent protection feature operates only when it is possible to do a circuit control normally.For safety, recommend installation a fuse, and so on in the "VCC" line.
 7. Because the IPM can be destroyed when the motor connection terminal (pins 2, 6, and 10) is opened while the motor is running, please be especially careful of the connection (soldering condition) of this terminal.
 8. The "ITRIP" terminal (16 pin) is the input terminal of the built-in comparator. It can stop movement by inputting the voltage more than Vref (0.44 V to 0.54 V). (At the time of movement, usually give me it for the voltage less than Vref).
Please use it as various protections such as the overcurrent protection (feedback from external shunt resistance).
In addition, the protection movement is not done a latch of.
After the protection movement end, I become the movement return state after typ.2ms. Therefore, please do the protection movement detection of all input signals in OFF (LOW) promptly afterward.
 9. When input pulse width is less than 1 μs , an output may not react to the pulse. (Both ON signal and OFF signal)
- This data shows the example of the application circuit and does not guarantee a design as the mass production set.

The characteristic of thermistor

Parameter	Symbol	Condition	Min	Typ.	Max	Unit
Resistance	R_{25}	T = 25°C	97	100	1034	kΩ
Resistance	R_{125}	T = 125°C	4.93	5.38	5.88	kΩ
B-Constant (25 to 50°C)	B		4165	4250	4335	k
Temperature Range			-40		+125	°C

■ This data shows the example of the application circuit, does not guarantee a design as the mass production set.

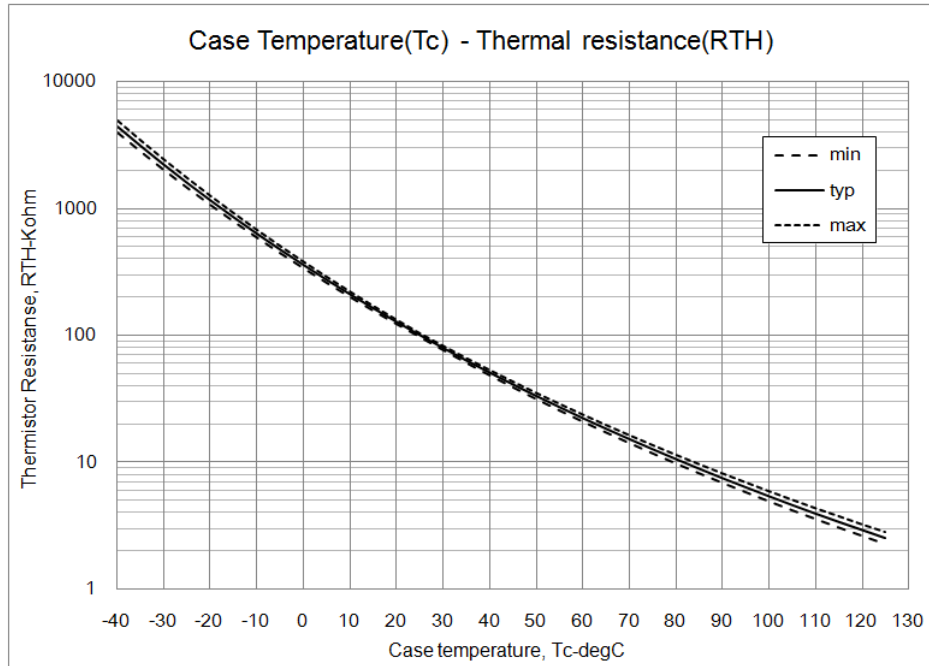

Fig.10 Variation of thermistor resistance with temperature

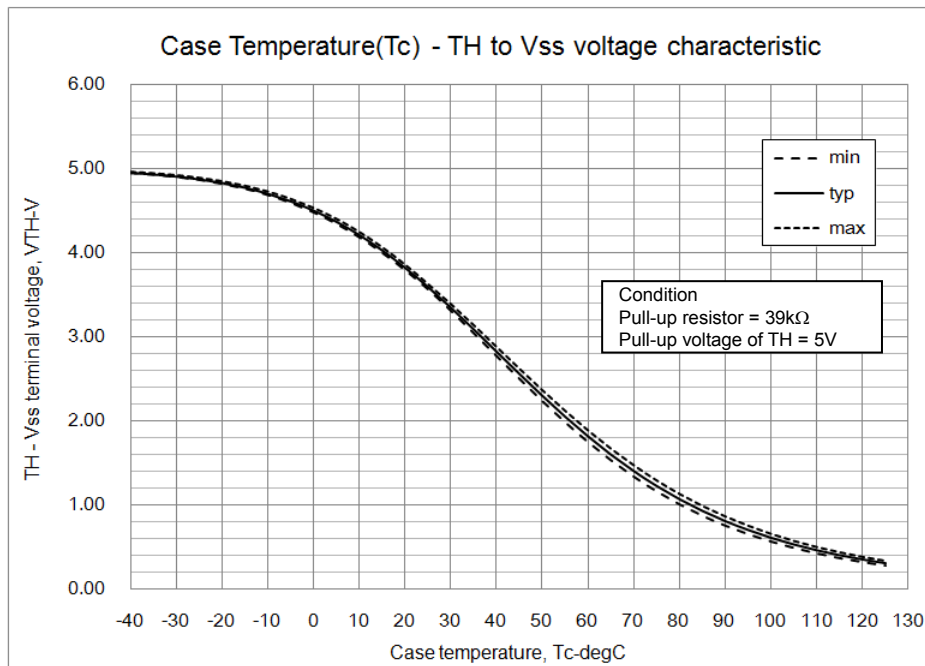

Fig.11 Variation of temperature sense voltage with thermistor temperature

The characteristic of PWM switching frequency

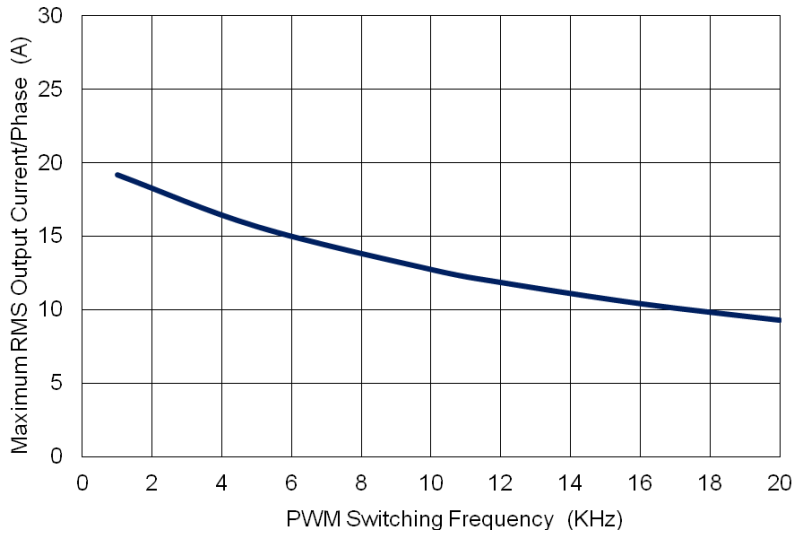

Fig.12 Maximum sinusoidal phase current as function of switching frequency at $T_c = 100^\circ\text{C}$, $V_{CC} = 300\text{ V}$

Switching waveform

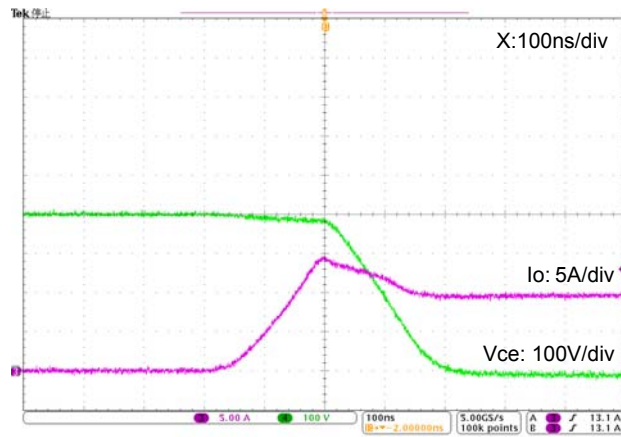

Fig. 13 IGBT Turn-on. Typical turn-on waveform at $T_c = 100^\circ\text{C}$, $V_{CC} = 400\text{ V}$, $I_o = 10\text{ A}$

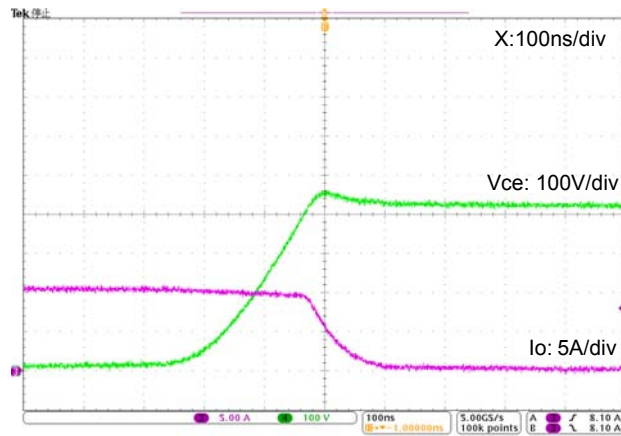

Fig. 14 IGBT Turn-off. Typical turn-off waveform $T_c = 100^\circ\text{C}$, $V_{CC} = 400\text{ V}$, $I_o = 10\text{ A}$

CB capacitor value calculation for bootstrap circuit

Calculate condition

Item	Symbol	Value	Unit
Upper side power supply.	VBS	15	V
Total gate charge of output power IGBT at 15 V.	Qg	89	nC
Upper side power supply low voltage protection.	UVLO	12	V
Upper side power dissipation.	IDMAX	400	μA
ON time required for CB voltage to fall from 15 V to UVLO	TONMAX	-	s

Capacitance calculation formula

Tonmax is upper arm maximum on time equal the time when the CB voltage falls from 15 V to the upper limit of Low voltage protection level.

“ton-maximum” of upper side is the time that CB decreases 15 V to the maximum low voltage protection of the upper side (12 V).

Thus, CB is calculated by the following formula.

$$VBS * CB - Qg - IDMAX * TONMAX = UVLO * CB$$

$$CB = (Qg + IDMAX * TONMAX) / (VBS - UVLO)$$

The relationship between tonmax and CB becomes as follows. CB is recommended to be approximately 3 times the value calculated above. The recommended value of Cb is in the range of 1 to 47 μF, however, the value needs to be verified prior to production.

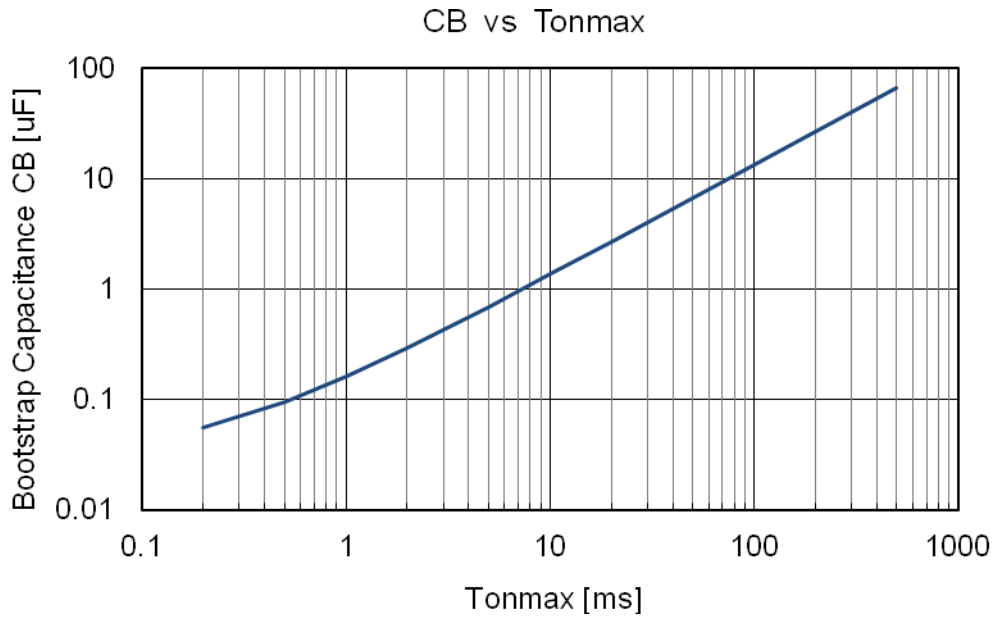

Fig.15 TONMAX vs CB characteristic

STK534U362C-E

Package Dimensions

unit : mm

SIP29 44x26.5

CASE 127CJ

ISSUE O

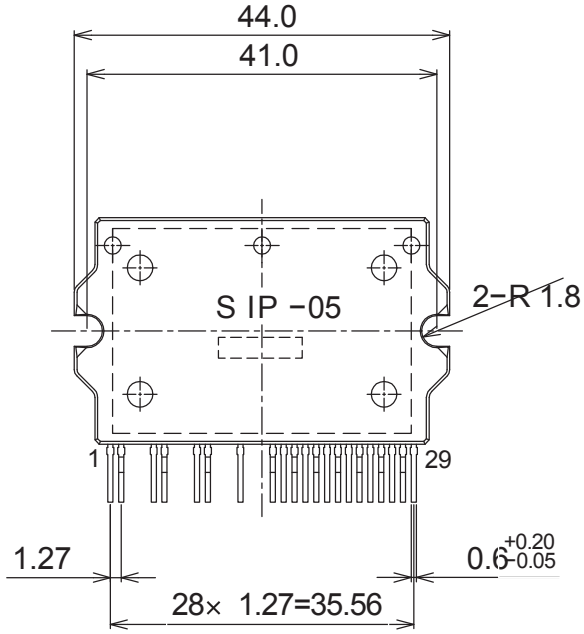

missing pin : 3, 4, 7, 8, 11, 12, 14, 15

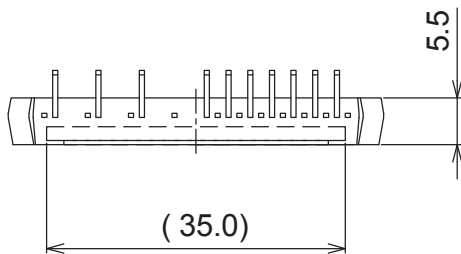
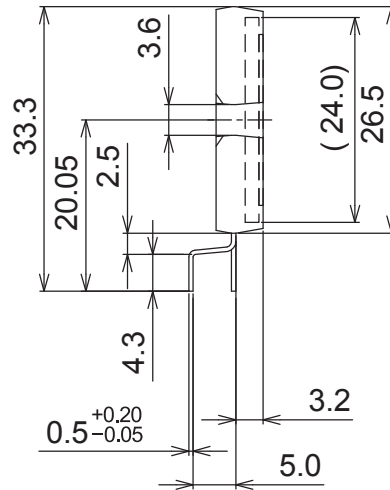

STK534U362C-E

ORDERING INFORMATION

Device	Package	Shipping (Qty / Packing)
STK534U362C-E	SIP29 44x26.5 (Pb-Free)	11 / Tube

ON Semiconductor and the ON Semiconductor logo are trademarks of Semiconductor Components Industries, LLC dba ON Semiconductor or its subsidiaries in the United States and/or other countries. ON Semiconductor owns the rights to a number of patents, trademarks, copyrights, trade secrets, and other intellectual property. A listing of ON Semiconductor's product/patent coverage may be accessed at www.onsemi.com/site/pdf/Patent-Marking.pdf. ON Semiconductor reserves the right to make changes without further notice to any products herein. ON Semiconductor makes no warranty, representation or guarantee regarding the suitability of its products for any particular purpose, nor does ON Semiconductor assume any liability arising out of the application or use of any product or circuit, and specifically disclaims any and all liability, including without limitation special, consequential or incidental damages. Buyer is responsible for its products and applications using ON Semiconductor products, including compliance with all laws, regulations and safety requirements or standards, regardless of any support or applications information provided by ON Semiconductor. "Typical" parameters which may be provided in ON Semiconductor data sheets and/or specifications can and do vary in different applications and actual performance may vary over time. All operating parameters, including "Typicals" must be validated for each customer application by customer's technical experts. ON Semiconductor does not convey any license under its patent rights nor the rights of others. ON Semiconductor products are not designed, intended, or authorized for use as a critical component in life support systems or any FDA Class 3 medical devices or medical devices with a same or similar classification in a foreign jurisdiction or any devices intended for implantation in the human body. Should Buyer purchase or use ON Semiconductor products for any such unintended or unauthorized application, Buyer shall indemnify and hold ON Semiconductor and its officers, employees, subsidiaries, affiliates, and distributors harmless against all claims, costs, damages, and expenses, and reasonable attorney fees arising out of, directly or indirectly, any claim of personal injury or death associated with such unintended or unauthorized use, even if such claim alleges that ON Semiconductor was negligent regarding the design or manufacture of the part. ON Semiconductor is an Equal Opportunity/Affirmative Action Employer. This literature is subject to all applicable copyright laws and is not for resale in any manner.

Looking for pricing, stock, or lifecycle information?

Click below to explore more details on WIN SOURCE:

 [View STK534U362C-E on WIN SOURCE](#)

 [ON Semiconductor](#) Information

Optimize Your Supply Chain with WIN SOURCE Solutions

-  Global Sourcing Solution
-  Obsolete Management
-  Cost Control Management
-  Shortage Management
-  Alternative Solution
-  Excess Inventory Management