



**THE DATASHEET OF  
STHDLS101AQTR**





# STHDLS101A

## Enhanced AC coupled HDMI level shifter with configurable HPD output

### Features

- Converts low-swing alternating current (AC) coupled differential input to high-definition multimedia interface (HDMI) rev 1.3 compliant
- HDMI level shifting operation up to 2.7 Gbps per lane
- Integrated 50  $\Omega$  termination resistors for AC-coupled differential inputs
- Input/output transition minimized differential signaling (TMDS) enable/disable
- Output slew rate control on TMDS outputs to minimize electromagnetic interference (EMI) and eliminate external components such as RC and choke
- Fail safe outputs for backdrive protection
- No re-timing or configuration required
- Inter-pair output skew < 250 ps, intra-pair output skew < 10 ps
- Single power supply of 3.3 V
- ESD protection:  $\pm 6$  KV HBM on all I/O pins
- Integrated display data channel (DDC) level shifters. Pass-gate voltage limiters allow 3.3 V termination on graphics and memory controller hub (GMCH) pins and 5 V DDC termination on HDMI connector pins
- Level shifter and configurable output for HPD signal from HDMI/DVI connector
- Integrated pull-down resistor on HPD\_SINK and OE\_N inputs

### Applications

- Notebooks, PC motherboards and graphic cards

**Table 1. Device summary**

Order code	Package	Packing
STHDLS101AQTR	QFN48 (7 x 7 x 1 mm)	Tape and reel

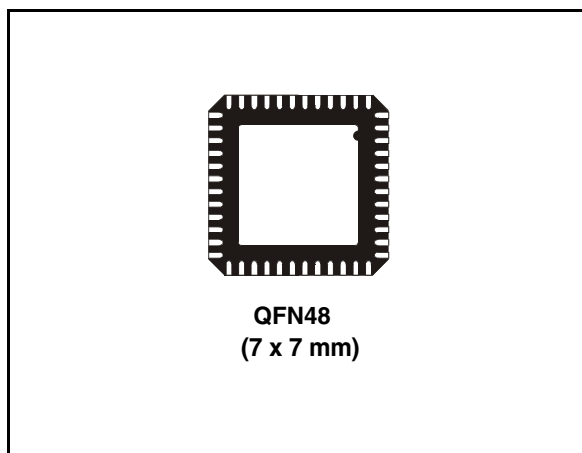

### Description

The STHDLS101A is a high-speed high-definition multimedia interface (HDMI) level shifter that converts low-swing AC coupled differential input to HDMI 1.3 compliant open-drain current steering RX-terminated differential output. Through the existing PCI-E pins in the graphics and memory controller hub (GMCH) of PCs or notebook motherboards, the pixel clock provides the required bandwidth (1.65 Gbps, 2.25 Gbps) for the video supporting 720p, 1080i, 1080p with a total of 36-bit resolution. The HDMI is multiplexed onto the PCIe pins in the motherboard where the AC coupled HDMI at 1.2 V is output by GMCH. The AC coupled HDMI is then level shifter by this device to 3.3 V DC coupled HDMI output.

The STHDLS101A supports up to 2.7 Gbps, which is enough for 12-bits of color depth per channel, as indicated in HDMI rev 1.3.

The device operates from a single 3.3 V supply and is available in a 48-pin QFN package.

# Contents

- 1      Block diagram ..... 3**
- 2      System interface ..... 4**
- 3      Pin configuration ..... 6**
  - 3.1    Pin description ..... 7
- 4      Functional description ..... 11**
- 5      Maximum ratings ..... 13**
  - 5.1    Recommended operating conditions ..... 14
    - 5.1.1    Power supply and temperature range ..... 14
    - 5.1.2    Differential inputs (IN\_D signals) ..... 14
  - 5.2    TMDS outputs (OUT\_D signals) ..... 15
  - 5.3    HPD input and output characteristics ..... 16
  - 5.4    DDC input and output characteristics ..... 17
  - 5.5    OE\_ input characteristics ..... 18
  - 5.6    HPD input resistor ..... 18
  - 5.7    ESD performance ..... 18
- 6      Application information ..... 19**
  - 6.1    Power supply sequencing ..... 19
  - 6.2    Supply bypassing ..... 19
  - 6.3    Differential traces ..... 19
- 7      Package mechanical data ..... 20**
- 8      Revision history ..... 23**

# 1 Block diagram

Figure 1. STHDLS101A block diagram

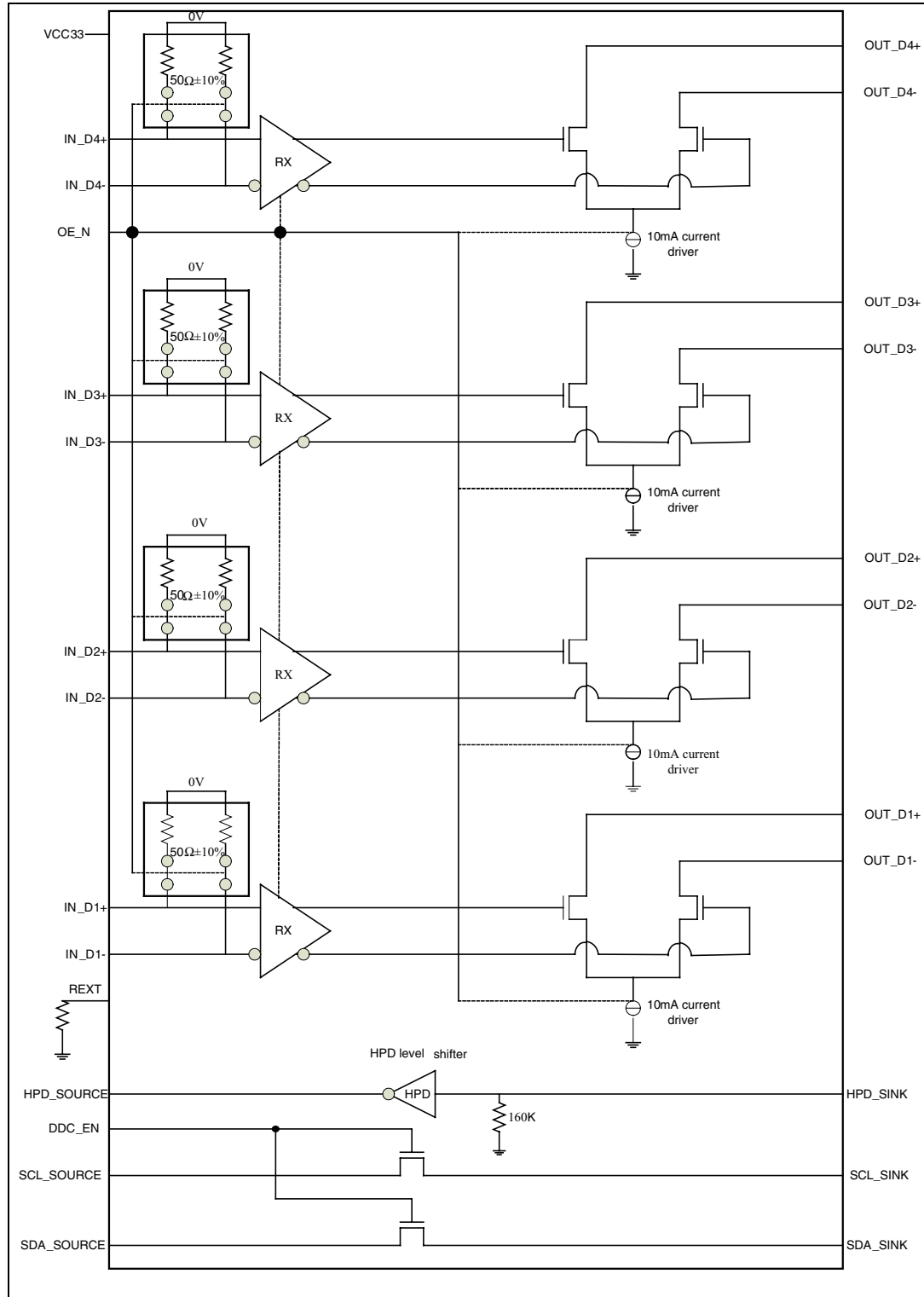

## 2 System interface

Figure 2. System interface

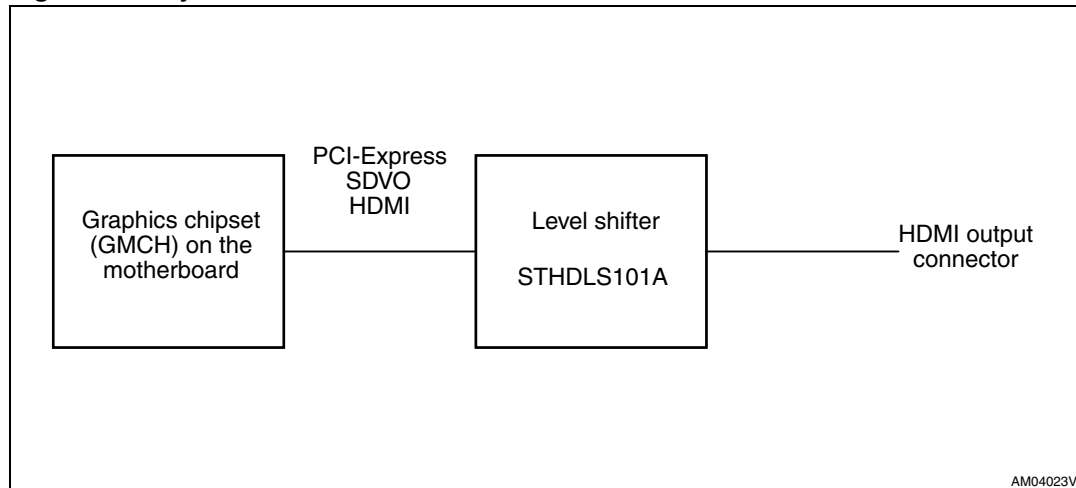

Figure 3. Cable adapter

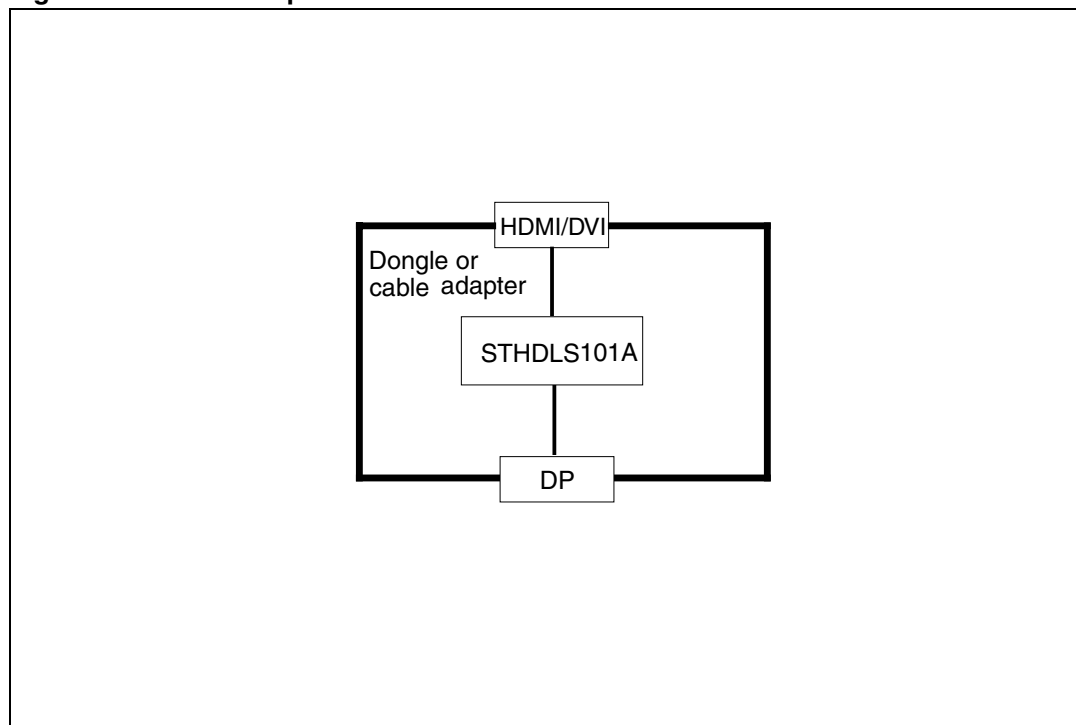
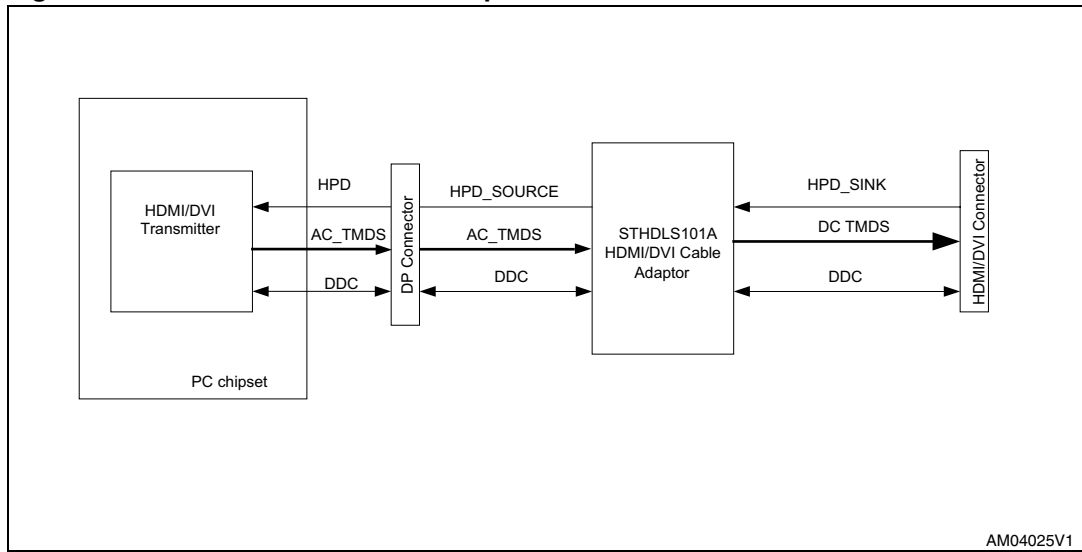
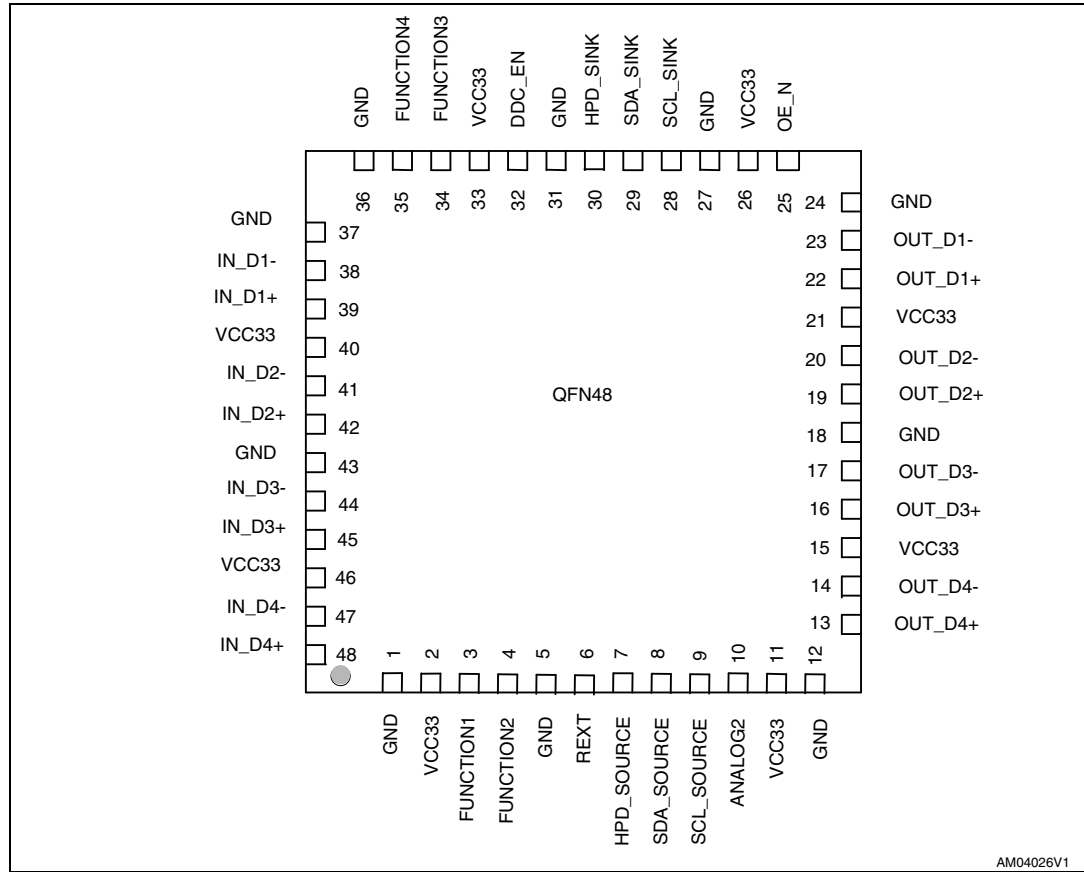

Figure 4. DP to HDMI/DVI cable adaptor



### 3 Pin configuration

Figure 5. STHDLS101A pin configuration



AM04026V1

### 3.1 Pin description

Table 2. Pin description

Pin number	Name	Type	Function		
1	GND	Power	Ground		
2	VCC33	Power	3.3 V±10% DC supply		
3	FUNCTION1	Vendor-specific control or test pins	Function pins are to enable vendor-specific features or test modes. For normal operation, these pins are tied to GND or VCC33 For consistent interoperability, GND is the preferred default connection for these signals. Provides equalizer 6dB lift at high frequencies		
4	FUNCTION2	Vendor-specific control or test pins	Function pins are to enable vendor-specific features or test modes For normal operation, these pins are tied to GND or VCC33 For consistent interoperability, GND is the preferred default connection for these signals. Provides 5 dB equalizer gain at all frequencies		
5	GND	Power	Ground		
6	REXT	Analog	Connection to external resistor. Resistor value specified by device manufacturer. Acceptable connections to this pin are: – Resistor to GND – Resistor to 3.3 V – NC (direct connections to V <sub>CC</sub> or GND are through a 0 Ω resistor for layout compatibility)		
7	HPD_SOURCE	Output	Buffer from the 0 V to 5 V input signal. The output buffer stage is configurable based on the FUNCTION3 pin settings as described in the table below:		
			<b>FUNCTION3</b>	<b>HPD_SINK</b>	<b>HPD_SOURCE</b>
			0	Low	Open-drain, connected an external pull up to the desired supply (normally 1 V)
			0	High (5 V)	Low (0 V)
			1	Low (0 V)	Low (0 V)
1	High (5 V)	High (3 V)			
8	SDA_SOURCE	I/O	3.3 V DDC data I/O. Pulled-up by external termination to 3.3 V. Connected to SDA_SINK through voltage-limiting integrated NMOS pass-gate		

Table 2. Pin description (continued)

Pin number	Name	Type	Function
9	SCL_SOURCE	Input	3.3 V DDC clock I/O. Pulled-up by external termination to 3.3 V. Connected to SCL_SINK through voltage-limiting integrated NMOS pass-gate
10	ANALOG2	Analog	Analog connection determined by vendor. Acceptable connections to this pin are: <ul style="list-style-type: none"> <li>– Resistor or capacitor to GND</li> <li>– Resistor or capacitor to 3.3 V</li> <li>– Short to 3.3 V or to GND</li> <li>– NC</li> </ul>
11	VCC33	Power	3.3 V $\pm$ 10% DC supply
12	GND	Power	Ground
13	OUT_D4+	Output	HDMI 1.3 compliant TMDS output OUT_D4+ makes a differential output signal with OUT_D4-
14	OUT_D4-	Output	HDMI 1.3 compliant TMDS output OUT_D4- makes a differential output signal with OUT_D4+
15	VCC33	Power	3.3 V $\pm$ 10% DC supply
16	OUT_D3+	Output	HDMI 1.3 compliant TMDS output OUT_D3+ makes a differential output signal with OUT_D3-
17	OUT_D3-	Output	HDMI 1.3 compliant TMDS output OUT_D3- makes a differential output signal with OUT_D3+.
18	GND	Power	Ground
19	OUT_D2+	Output	HDMI 1.3 compliant TMDS output OUT_D2+ makes a differential output signal with OUT_D2-.
20	OUT_D2-	Output	HDMI 1.3 compliant TMDS output OUT_D2- makes a differential output signal with OUT_D2+
21	VCC33	Power	3.3 V $\pm$ 10% DC supply
22	OUT_D1+	Output	HDMI 1.3 compliant TMDS output. OUT_D1+ makes a differential output signal with OUT_D1-
23	OUT_D1-	Output	HDMI 1.3 compliant TMDS output. OUT_D1- makes a differential output signal with OUT_D1+
24	GND	Power	Ground

**Table 2. Pin description (continued)**

Pin number	Name	Type	Function		
25	OE_N	Input	Enable for level shifter path. 3.3 V tolerant low-voltage single-ended input. Internal pull-down enables chip when unconnected		
			<b>OE_N</b>	<b>IN_D termination</b>	<b>OUT_D Outputs</b>
			1	High-Z	High-Z
			0	50 Ω	Active
26	VCC33	Power	3.3 V±10% DC supply		
27	GND	Power	Ground		
28	SCL_SINK	Output	5 V DDC Clock I/O. Pulled-up by external termination to 5 V. Connected to SCL_SOURCE through voltage-limiting integrated NMOS pass-gate		
29	SDA_SINK	I/O	5V DDC Data I/O. Pulled-up by external termination to 5V. Connected to SDA_SOURCE through voltage-limiting integrated NMOS pass-gate		
30	HPD_SINK	Input	Low-frequency, 0V to 5V (nominal) input signal. This signal comes from the HDMI connector. Voltage high indicates “plugged” state; voltage low indicates “unplugged” state. HPD_SINK is pulled down by an integrated 160KΩ pull-down resistor		
31	GND	Power	Ground		
32	DDC_EN	Input	Enables bias voltage to the DDC pass-gate level shifter gates. (May be implemented as a bias voltage connection to the DDC pass-gate themselves)		
			<b>DDC_EN</b>	<b>Pass-gate</b>	
			0 V	Disabled	
			3.3 V	Enabled	
33	VCC33	Power	3.3 V±10% DC supply		
34	FUNCTION3	Input	Used for polarity control of the HPD_SOURCE output. When L, the HPD_SOURCE is an open-drain output and when H, the HPD_SOURCE is a buffered output (0 V to V <sub>CC</sub> )		
35	FUNCTION4	Vendor-specific control or test pins	Function pins are to enable vendor-specific features or test modes For normal operation, these pins are tied to GND or VCC33 For consistent interoperability, GND is the preferred default connection for these signals		
36	GND	Power	Ground		
37	GND	Power	Ground		

Table 2. Pin description (continued)

Pin number	Name	Type	Function
38	IN_D1-	Input	Low-swing differential input from GMCH PCIE outputs. IN_D1- makes a differential pair with IN_D1+
39	IN_D1+	Input	Low-swing differential input from GMCH PCIE outputs. IN_D1+ makes a differential pair with IN_D1-
40	VCC33	Power	3.3 V $\pm$ 10% DC supply
41	IN_D2-	Input	Low-swing differential input from GMCH PCIE outputs. IN_D2- makes a differential pair with IN_D2+
42	IN_D2+	Input	Low-swing differential input from GMCH PCIE outputs. IN_D2+ makes a differential pair with IN_D2-
43	GND	Power	Ground
44	IN_D3-	Input	Low-swing differential input from GMCH PCIE outputs. IN_D3- makes a differential pair with IN_D3+
45	IN_D3+	Input	Low-swing differential input from GMCH PCIE outputs. IN_D3+ makes a differential pair with IN_D3-
46	VCC33	Power	3.3 V $\pm$ 10% DC supply
47	IN_D4-	Input	Low-swing differential input from GMCH PCIE outputs. IN_D4- makes a differential pair with IN_D4+
48	IN_D4+	Input	Low-swing differential input from GMCH PCIE outputs. IN_D4+ makes a differential pair with IN_D4-

## 4 Functional description

The section describes the basic functionality of the STHDLS101A device.

### Power supply

The STHDLS101A is powered by a single DC power supply of 3.3 V ± 10%.

### Clocking

This device does not retime any data. The device contains no state machines. No inputs or outputs of the device are latched or clocked.

### Reset

This device acts as a level shifter, reset is not required.

### OE\_N function

When OE\_N is asserted (low level), the IN\_D and OUT\_D signals are fully functional. Input termination resistors are enabled and any internal bias circuits are turned on.

OE\_N pin has an internal pull-down that enables the chip if left unconnected.

When OE\_N is de-asserted (high level), the OUT\_D outputs are in high impedance state.

The IN\_D input buffers are disabled and the IN\_D termination resistors are disabled.

Internal bias circuits for the differential inputs and outputs are turned off. Power consumption of the chip is minimized.

The HPD\_SINK input and HPD\_SOURCE output are not affected by OE\_N. The SCL and SDA pass-gates are not affected by OE\_N.

**Table 3. OE\_N description**

OE_N	Device state	Comments
Asserted (low level) or unconnected	Differential input buffers and output buffers enabled. Input impedance = 50Ω	Normal functioning state for IN_D to OUT_D level shifting function.
De-asserted (high level)	<p>Low-power state.</p> <p>Differential input buffers and terminations are disabled. Differential input buffers are in high-impedance state.</p> <p>OUT_D level shifting outputs are disabled. OUT_D level shifting outputs are in a high-impedance state.</p> <p>Internal bias currents are turned off.</p>	<p>Intended for lowest power condition when:</p> <ul style="list-style-type: none"> <li>• No display is plugged in or</li> <li>• The level shifted data path is disabled</li> </ul> <p>HPD_SINK input and HPD_SOURCE output are not affected by OE_N.</p> <p>SCL_SOURCE, SCL_SINK, SDA_SOURCE and SDA_SINK signals and functions are not affected by OE_N.</p>

**Table 4. OE\_N function**

OE_N	IN_Dx	OUT_Dx (TMDS outputs)	Notes
De-asserted (high level)	High-Z	High-Z	Device disabled. Low power state. Internal bias currents are disabled.
Asserted or unconnected (low level)	50 $\Omega$ termination	Enabled	Level shifting mode enabled.

## 5 Maximum ratings

Stressing the device above the rating listed in the “Absolute maximum ratings” table may cause permanent damage to the device. These are stress ratings only and operation of the device at these or any other conditions above those indicated in the Operating sections of this specification is not implied. Exposure to Absolute maximum rating conditions for extended periods may affect device reliability.

**Table 5. Absolute maximum ratings**

Symbol	Parameter		Value	Unit
V <sub>CC</sub>	Supply voltage to ground potential		-0.5 to +4.0	V
V <sub>I</sub>	DC input voltage (TMDS and PCIe ports)		-0.5 to +4.0	V
	Control pins		-0.5 to +4.0	V
	SDA_SINK, SCL_SINK, HPD_SINK pins		-0.5 to +6	V
I <sub>O</sub>	DC output current		120	mA
P <sub>D</sub>	Power dissipation		1	W
T <sub>STG</sub>	Storage temperature		-65 to +150	°C
T <sub>L</sub>	Lead temperature (10 sec)		300	°C
V <sub>ESD</sub>	Electrostatic discharge voltage on IOs <sup>(1)</sup>	Human body model	±6	kV

1. In accordance with the MIL standard 883 method 3015

**Table 6. Thermal data**

Symbol	Parameter	QFN48	Unit
θ <sub>JA</sub>	Junction-ambient thermal coefficient	48	°C/W

## 5.1 Recommended operating conditions

### 5.1.1 Power supply and temperature range

Table 7. Power supply and temperature range

Symbol	Parameter	Comments	Min	Typ	Max	Unit
$V_{CC33}$	3.3 V power supply		3.0	3.3	3.6	V
$I_{CC}$	Maximum power supply current	Total current from $V_{CC}$ 3.3 V power supply	–	–	120	mA
T	Operating temperature range		-40	–	85	°C

### 5.1.2 Differential inputs (IN\_D signals)

Table 8. Differential input characteristics for IN\_D signals

Symbol	Parameter	Comments	Min	Typ	Max	Unit
Tbit	Unit interval	Tbit is determined by the display mode. Nominal bit rate ranges from 250 Mbps to 2.5 Gbps per lane. Nominal Tbit at 2.5 Gbps = 400 ps. 360 ps = 400 ps – 10%	360	–	–	ps
$V_{RX-DIFFp-p}$	Differential input peak to peak voltage	$V_{RX-DIFFp-p}=2* V_{RX-D+} - V_{RX-D-} $ . Applies to IN_D signals.	0.2	–	1.2	V
$T_{RX-EYE}$	Minimum eye width at IN_D input pair	The level shifter may add a maximum of 0.02UI jitter	0.8	–	–	Tbit
$V_{CM-AC-pp}$	AC peak common mode input voltage	$V_{CM-AC-pp}= V_{RX-D+} + V_{RX-D-} /2 - V_{RX-CM-DC}$ . $V_{RX-CM-DC}=DC(avg)$ of $ V_{RX-D+} + V_{RX-D-} /2$ VCM-AC-pp includes all frequencies above 30 kHz.	–	–	100	mV
$Z_{RX-DC}$	DC single-ended input impedance	Applies to IN_D+ as well as IN_D- pins (50 $\Omega$ $\pm$ 20% tolerance)	40	50	60	$\Omega$
$V_{RX-Bias}$	RX input termination voltage	Intended to limit power-up stress on chipset's PCIE output buffers	0	–	2	V
$Z_{RX-HIGH-Z}$	Single-ended input resistance for IN_Dx when inputs are in high-Z state	Differential inputs must be in a high impedance state	100	–	–	K $\Omega$

## 5.2 TMDS outputs (OUT\_D signals)

The level shifter’s TMDS outputs are required to meet the HDMI 1.3 specifications. The HDMI 1.3 specification is assumed to be the correct reference in instances where this document conflicts with the HDMI 1.3 specification.

**Table 9. Differential output characteristics for TMDS OUT\_D signals**

Symbol	Parameter	Comments	Min	Typ	Max	Unit
$V_H$	Single-ended high level output voltage	$AV_{CC}$ is the DC termination voltage in the HDMI or DVI sink. $AV_{CC}$ is nominally 3.3 V	$AV_{CC}-10\text{ mV}$	$AV_{CC}$	$AV_{CC}+10\text{ mV}$	V
$V_L$	Single-ended low level output voltage	The open-drain output pulls down form $AV_{CC}$	$AV_{CC}-600\text{ mV}$	$AV_{CC}-500\text{ mV}$	$AV_{CC}-400\text{ mV}$	V
$V_{SWING}$	Single-ended output swing voltage	Swing down from TMDS termination voltage (3.3 V $\pm$ 10%)	400 mV	500 mV	600 mV	V
$I_{OFF}$	Single-ended current in high-Z state	Measured with TMDS outputs pulled up to $AV_{CC}$ max (3.6 V) through 50 $\Omega$ resistors	–	–	10	$\mu$ A
$T_R$	Rise time	Maximum rise/fall time at 2.7 Gbps = 148ps. 125ps = 148 – 15%	125 ps	–	0.4 Tbit	ps
$T_F$	Fall time	Maximum rise/fall time at 2.7 Gbps = 148 ps. 125ps = 148 – 15%	125 ps	–	0.4 Tbit	ps
$T_{SKEW-INTRA}$	Intra-pair differential skew	This differential skew budget is in addition to the skew presented between D+ and D-paired input pins.	–	–	10	ps
$T_{SKEW-INTER}$	Inter-pair lane to lane output skew	This lane to lane skew budget is in addition to the skew between differential input pairs.	–	–	250	ps
$T_{JIT}$	Jitter added to TMDS signals	Jitter budget for TMDS signals as they pass through the level shifter. 7.4 ps = 0.02 Tbit at 2.7 Gbps	–	–	7.4	ps

### 5.3 HPD input and output characteristics

Table 10. HPD\_SINK input and HPS\_SOURCE output

Symbol	Parameter	Comment	Min	Typ	Max	Unit
$V_{IH-HPD\_SINK}$	HPD_SINK input high level	Low speed input changes state on cable plug/unplug	2	5.0	5.3	V
$V_{IL-HPD\_SINK}$	HPD_SINK input low level		0	–	0.8	V
$I_{IN-HPD\_SINK}$	HPD_SINK input leakage current	Measured with HPD_SINK at $V_{IH-HPD}$ max and $V_{IL-HPD}$ min	–	–	50	$\mu$ A
$V_{OL-HPD\_SOURCE}$	HPD_SOURCE output low level when FUNCTION3 = H	$V_{CC} = 3.3\text{ V} \pm 10\%$	2.5	–	$V_{CC}$	V
$V_{OH-HPD\_SOURCE (INV)}$	HPD_SOURCE output high level when FUNCTION3 = L	$V_{CC} = 3.3\text{ V} \pm 10\%$ $I_{OL} = 1\text{ mA}$	0	–	0.2	V
$V_{OL-HPD\_SOURCE}$	HPD_SOURCE output low level when FUNCTION3 = H	$V_{CC} = 3.3\text{ V} \pm 10\%$	0	–	0.2	V
$T_{HPD}$	HPD_SINK to HPD_SOURCE propagation delay	Time from HPD_SINK changing state to HPD_SOURCE changing state. Includes HPD_SOURCE rise/fall time $C_L = 10\text{ pF}$	–	–	200	ns
$T_{RF-HPD}$	HPD_SOURCE rise/fall time	Time required to transition from $V_{OH-HPD\_SOURCE}$ to $V_{OL-HPD\_SOURCE}$ or from $V_{OL-HPD\_SOURCE}$ to $V_{OH-HPD\_SOURCE}$ $C_L = 10\text{ pF}$	1	–	20	ns

### 5.4 DDC input and output characteristics

Table 11. SDA\_SOURCE, SCL\_SOURCE and SDA\_SINK, SCL\_SINK characteristics

Symbol	Parameter	Comment	Min	Typ	Max	Unit
V <sub>I</sub>	Input voltage on SDA_SINK, SCL_SINK pins	Voltage on the DDC pins on connector end	0	–	5.5	V
I <sub>LKG</sub>	Input leakage current on SDA_SINK, SCL_SINK pins	V <sub>CC</sub> = 3.3 V V <sub>I</sub> = 0.1 V <sub>DD</sub> to 0.9 V <sub>DD</sub> to isolated DDC inputs V <sub>DD</sub> = external pull-up resistor voltage on SDA_SINK and SCL_SINK inputs (maximum of 5.5 V)	-10	–	10	µA
I <sub>OFF</sub>	Power-down leakage current on SDA_SINK, SCL_SINK pins	V <sub>CC</sub> = 0.0 V V <sub>I</sub> = 0.1 V <sub>DD</sub> to 0.9 V <sub>DD</sub> to DDC sink inputs V <sub>DD</sub> = external pull-up resistor voltage on SDA_SINK and SCL_SINK inputs (maximum of 5.5 V) SDA_SOURCE, SCL_SOURCE = 0.0 V	-10	–	10	µA
C <sub>I/O</sub>	Input/output capacitance (switch off)	V <sub>I(pp)</sub> = 1 V, 100 KHz V <sub>CC</sub> = 3.3 V, T = 25°C	–	5	–	pF
C <sub>I/O</sub>	Input/output capacitance (switch on)	V <sub>I(pp)</sub> = 1 V, 100KHz V <sub>CC</sub> = 3.3 V, T = 25 °C	–	–	10	pF
R <sub>ON</sub>	Switch resistance	I <sub>O</sub> = 3 mA, V <sub>O</sub> = 0.4 V V <sub>CC</sub> = 3.3 V	–	27	40	Ω
T <sub>PD</sub>	DDC_SINK to DDC_SOURCE propagation delay	Time from DDC_SINK changing state to DDC_SOURCE changing state while the pass gate is enabled. C <sub>L</sub> = 10 pF R <sub>PU</sub> = 1.5 K (min), 2.0 K (max)	–	8	15	ns
T <sub>SX</sub>	Switch time from DDC_EN to the valid state on DDC_SOURCE	C <sub>L</sub> = 10 pF R <sub>PU</sub> = 1.5 K (min), 2.0 K (max)	–	8	15	ns

## 5.5 OE\_ input characteristics

Table 12. OE\_N input characteristics

Symbol	Parameter	Comment	Min	Typ	Max	Unit
$V_{IH-OE\_N}$	Input high level		2	–	VCC33	V
$V_{IL-OE\_N}$	Input low level		0	–	0.8	V
$I_{IN-OE\_N}$	Input leakage current	Measured with OE_N at $V_{IH-OE\_N}$ max and $V_{IL-OE\_N}$ min	–	–	200	$\mu$ A

## 5.6 HPD input resistor

Table 13. HDP input resistor

Symbol	Parameter	Comment	Min	Typ	Max	Unit
$R_{HPD}$	HPD_SINK input pull-down resistor	Guarantees HPD_SINK is LOW when no display is plugged in	130 K	160 K	190 K	$\Omega$

## 5.7 ESD performance

Table 14. ESD performance

Symbol	Parameter	Test condition	Min	Typ	Max	Unit
ESD	MIL STD 883 method 3015 (all pins)	Human Body Model (HBM)	-6	–	+6	kV

## 6 Application information

### 6.1 Power supply sequencing

Proper power-supply sequencing is advised for all CMOS devices. It is recommended to always apply  $V_{CC}$  before applying any signals to the input/output or control pins.

### 6.2 Supply bypassing

Bypass each of the  $V_{CC}$  pins with 0.1  $\mu$ F and 1nF capacitors in parallel as close to the device as possible, with the smaller-valued capacitor as close to the  $V_{CC}$  pin of the device as possible.

### 6.3 Differential traces

The high-speed inputs and TMD5 outputs are the most critical parts for the device. There are several considerations to minimize discontinuities on these transmission lines between the connectors and the device.

- (a) Maintain 100  $\Omega$  differential transmission line impedance into and out of the device.
- (b) Keep an uninterrupted ground plane below the high-speed I/Os.
- (c) Keep the ground-path vias to the device as close as possible to allow the shortest return current path.
- (d) Layout of the TMD5 differential outputs should be with the shortest stubs from the connectors.

Output trace characteristics affect the performance of the STHDL101A. Use controlled impedance traces to match trace impedance to both the transmission medium impedance and termination resistor. Run the differential traces close together to minimize the effects of the noise. Reduce skew by matching the electrical length of the traces. Avoid discontinuities in the differential trace layout. Avoid 90 degree turns and minimize the number of vias to further prevent impedance discontinuities.

# 7 Package mechanical data

In order to meet environmental requirements, ST offers these devices in different grades of ECOPACK® packages, depending on their level of environmental compliance. ECOPACK® specifications, grade definitions and product status are available at: [www.st.com](http://www.st.com). ECOPACK® is an ST trademark.

**Figure 6. Package outline for QFN48 (7 x 7 x 1 mm) - 0.5 mm pitch**

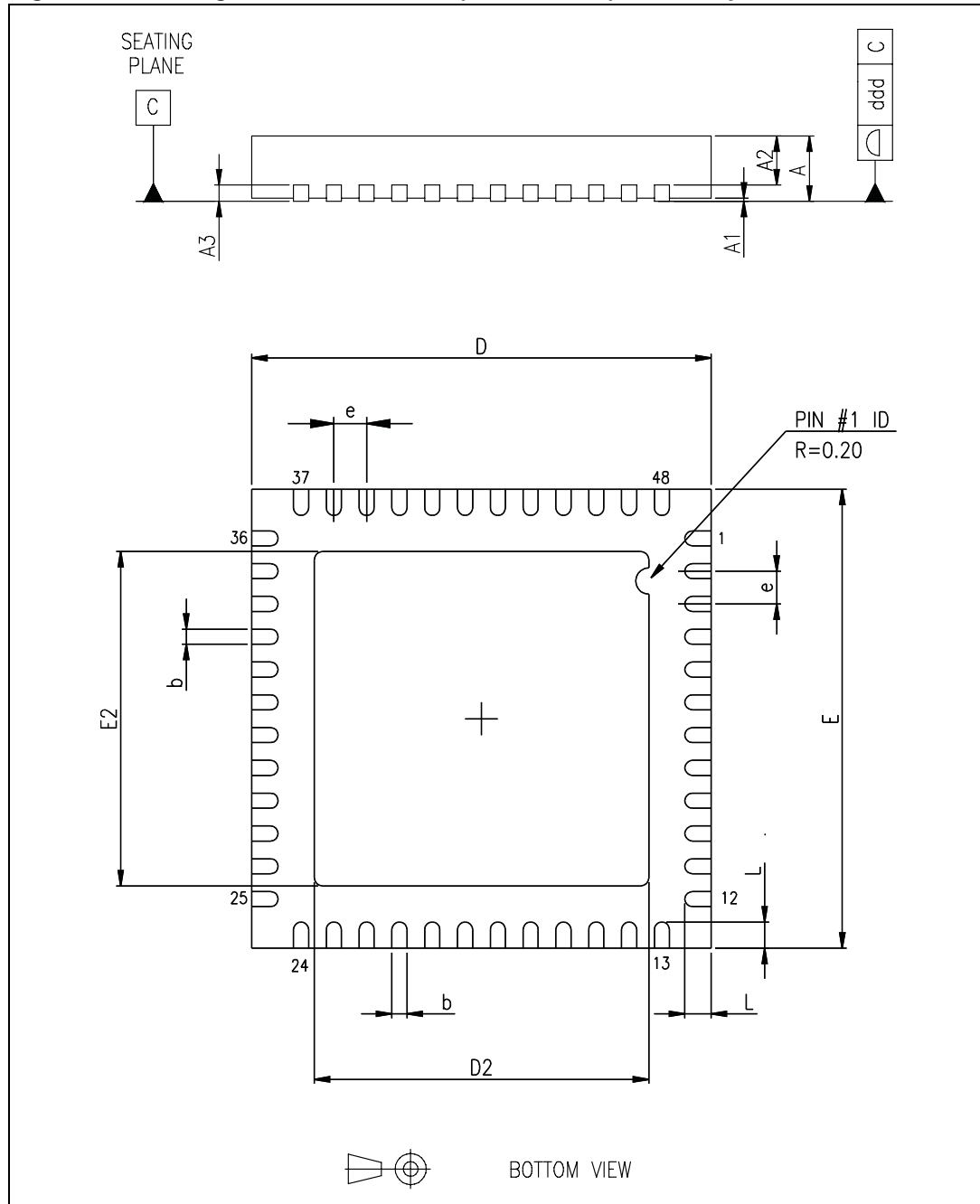

**Table 15. Package mechanical data for QFN48 (7 x 7 x 1 mm) - 0.5 mm pitch**

Symbol	Min	Typ	Max	Min	Typ	Max
A	0.80	0.90	1.00	0.80	0.85	1.00
A1	—	0.02	0.05	—	0.01	0.05
A2	—	0.65	1.00	—	0.65	—
A3	—	0.25	—	—	0.20	—
b	0.18	0.23	0.30	0.18	0.23	0.30
D	6.85	7.00	7.15	6.90	7.00	7.10
D2	2.25	4.70	5.25	SEE EXPOSED PAD VARIATIONS		
E	6.85	7.00	7.15	6.90	7.00	7.10
E2	2.25	4.70	5.25	SEE EXPOSED PAD VARIATIONS		
e	0.45	0.50	0.55	0.45	0.50	0.55
L	0.30	0.40	0.50	0.30	0.40	0.50
ddd	—	—	0.08	—	—	0.08

**Figure 7. Tape information for QFN48 (7 x 7 x 1 mm) - 0.5 mm pitch**

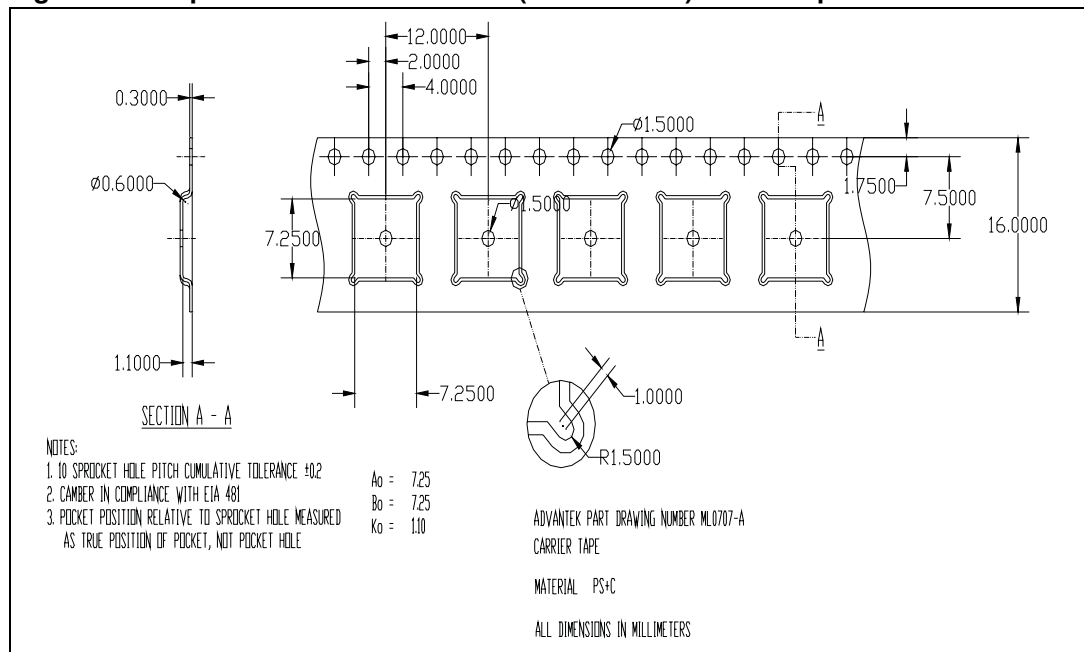

Figure 8. Reel information for QFN48 (7 x 7 x 1 mm) - 0.5 mm pitch

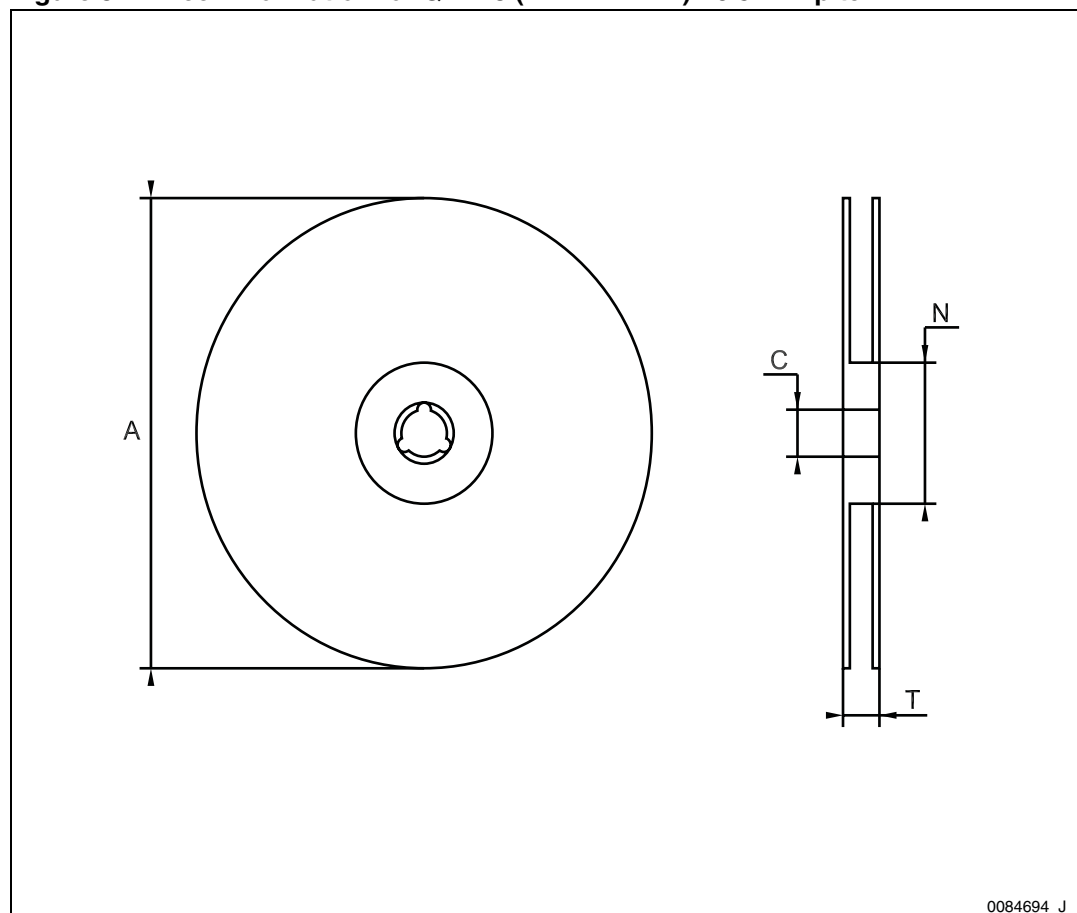

Table 16. Reel mechanical data (dimensions in mm)

A	C	N	T
330.2	13 ±0.25	100	16.4

## 8 Revision history

Table 17. Document revision history

Date	Revision	Changes
22-Jun-2009	1	Initial release.

**Please Read Carefully:**

Information in this document is provided solely in connection with ST products. STMicroelectronics NV and its subsidiaries ("ST") reserve the right to make changes, corrections, modifications or improvements, to this document, and the products and services described herein at any time, without notice.

All ST products are sold pursuant to ST's terms and conditions of sale.

Purchasers are solely responsible for the choice, selection and use of the ST products and services described herein, and ST assumes no liability whatsoever relating to the choice, selection or use of the ST products and services described herein.

No license, express or implied, by estoppel or otherwise, to any intellectual property rights is granted under this document. If any part of this document refers to any third party products or services it shall not be deemed a license grant by ST for the use of such third party products or services, or any intellectual property contained therein or considered as a warranty covering the use in any manner whatsoever of such third party products or services or any intellectual property contained therein.

**UNLESS OTHERWISE SET FORTH IN ST'S TERMS AND CONDITIONS OF SALE ST DISCLAIMS ANY EXPRESS OR IMPLIED WARRANTY WITH RESPECT TO THE USE AND/OR SALE OF ST PRODUCTS INCLUDING WITHOUT LIMITATION IMPLIED WARRANTIES OF MERCHANTABILITY, FITNESS FOR A PARTICULAR PURPOSE (AND THEIR EQUIVALENTS UNDER THE LAWS OF ANY JURISDICTION), OR INFRINGEMENT OF ANY PATENT, COPYRIGHT OR OTHER INTELLECTUAL PROPERTY RIGHT.**

**UNLESS EXPRESSLY APPROVED IN WRITING BY AN AUTHORIZED ST REPRESENTATIVE, ST PRODUCTS ARE NOT RECOMMENDED, AUTHORIZED OR WARRANTED FOR USE IN MILITARY, AIR CRAFT, SPACE, LIFE SAVING, OR LIFE SUSTAINING APPLICATIONS, NOR IN PRODUCTS OR SYSTEMS WHERE FAILURE OR MALFUNCTION MAY RESULT IN PERSONAL INJURY, DEATH, OR SEVERE PROPERTY OR ENVIRONMENTAL DAMAGE. ST PRODUCTS WHICH ARE NOT SPECIFIED AS "AUTOMOTIVE GRADE" MAY ONLY BE USED IN AUTOMOTIVE APPLICATIONS AT USER'S OWN RISK.**

Resale of ST products with provisions different from the statements and/or technical features set forth in this document shall immediately void any warranty granted by ST for the ST product or service described herein and shall not create or extend in any manner whatsoever, any liability of ST.

ST and the ST logo are trademarks or registered trademarks of ST in various countries.

Information in this document supersedes and replaces all information previously supplied.

The ST logo is a registered trademark of STMicroelectronics. All other names are the property of their respective owners.

© 2009 STMicroelectronics - All rights reserved

STMicroelectronics group of companies

Australia - Belgium - Brazil - Canada - China - Czech Republic - Finland - France - Germany - Hong Kong - India - Israel - Italy - Japan - Malaysia - Malta - Morocco - Philippines - Singapore - Spain - Sweden - Switzerland - United Kingdom - United States of America

[www.st.com](http://www.st.com)

## Looking for pricing, stock, or lifecycle information?

Click below to explore more details on WIN SOURCE:

- ⊖ [View STHDLS101AQTR on WIN SOURCE](#)
- ⊖ [STMicroelectronics Information](#)

## Optimize Your Supply Chain with WIN SOURCE Solutions

- ✓ Global Sourcing Solution
- ✓ Obsolete Management
- ✓ Cost Control Management
- ✓ Shortage Management
- ✓ Alternative Solution
- ✓ Excess Inventory Management