



**THE DATASHEET OF
ST72F521R9T6**





ST72F521, ST72521B

80/64-PIN 8-BIT MCU WITH 32 TO 60K FLASH/ROM, ADC, FIVE TIMERS, SPI, SCI, I²C, CAN INTERFACE

■ Memories

- 32K to 60K dual voltage High Density Flash (HDFlash) or ROM with read-out protection capability. In-Application Programming and In-Circuit Programming for HDFlash devices
- 1K to 2K RAM
- HDFlash endurance: 100 cycles, data retention: 20 years at 55°C

■ Clock, Reset And Supply Management

- Enhanced low voltage supervisor (LVD) for main supply and auxiliary voltage detector (AVD) with interrupt capability
- Clock sources: crystal/ceramic resonator oscillators, internal RC oscillator and bypass for external clock
- PLL for 2x frequency multiplication
- Four power saving modes: Halt, Active-Halt, Wait and Slow

■ Interrupt Management

- Nested interrupt controller
- 14 interrupt vectors plus TRAP and RESET
- Top Level Interrupt (TLI) pin
- 15 external interrupt lines (on 4 vectors)

■ Up to 64 I/O Ports

- 48 multifunctional bidirectional I/O lines
- 34 alternate function lines
- 16 high sink outputs

■ 5 Timers

- Main Clock Controller with: Real time base, Beep and Clock-out capabilities
- Configurable watchdog timer
- Two 16-bit timers with: 2 input captures, 2 output compares, external clock input on one timer, PWM and pulse generator modes
- 8-bit PWM Auto-Reload timer with: 2 input captures, 4 PWM outputs, output compare and time base interrupt, external clock with event detector

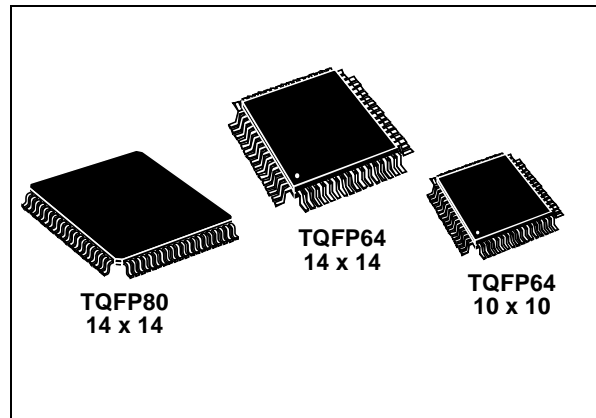

■ 4 Communications Interfaces

- SPI synchronous serial interface
- SCI asynchronous serial interface
- I²C multimaster interface (SMBus V1.1 compliant)
- CAN interface (2.0B Passive)

■ Analog peripheral (low current coupling)

- 10-bit ADC with 16 input robust input ports

■ Instruction Set

- 8-bit Data Manipulation
- 63 Basic Instructions
- 17 main Addressing Modes
- 8 x 8 Unsigned Multiply Instruction

■ Development Tools

- Full hardware/software development package
- In-Circuit Testing capability

Device Summary

Features	ST72F521(M/R/AR)9	ST72F521(R/AR)6	ST72521B(M/R/AR)9	ST72521B(R/AR)6
Program memory - bytes	Flash 60K	Flash 32K	ROM 60K	ROM 32K
RAM (stack) - bytes	2048 (256)	1024 (256)	2048 (256)	1024 (256)
Operating Voltage	3.8V to 5.5V			
Temp. Range	up to -40°C to +125 °C			
Package	TQFP80 14x14 (M), TQFP64 14x14 (R), TQFP64 10x10 (AR)	TQFP64 14x14 (R), TQFP64 10x10 (AR)	TQFP80 14x14 (M), TQFP64 14x14 (R), TQFP64 10x10 (AR)	TQFP64 14x14 (R), TQFP64 10x10 (AR)

Rev. 5

Table of Contents

1 INTRODUCTION	7
2 PIN DESCRIPTION	8
3 REGISTER & MEMORY MAP	14
4 FLASH PROGRAM MEMORY	18
4.1 INTRODUCTION	18
4.2 MAIN FEATURES	18
4.3 STRUCTURE	18
4.3.1 Read-out Protection	18
4.4 ICC INTERFACE	19
4.5 ICP (IN-CIRCUIT PROGRAMMING)	20
4.6 IAP (IN-APPLICATION PROGRAMMING)	20
4.7 RELATED DOCUMENTATION	20
4.7.1 Register Description	20
5 CENTRAL PROCESSING UNIT	21
5.1 INTRODUCTION	21
5.2 MAIN FEATURES	21
5.3 CPU REGISTERS	21
6 SUPPLY, RESET AND CLOCK MANAGEMENT	24
6.1 PHASE LOCKED LOOP	24
6.2 MULTI-OSCILLATOR (MO)	25
6.3 RESET SEQUENCE MANAGER (RSM)	26
6.3.1 Introduction	26
6.3.2 Asynchronous External RESET pin	26
6.3.3 External Power-On RESET	27
6.3.4 Internal Low Voltage Detector (LVD) RESET	27
6.3.5 Internal Watchdog RESET	27
6.4 SYSTEM INTEGRITY MANAGEMENT (SI)	28
6.4.1 Low Voltage Detector (LVD)	28
6.4.2 Auxiliary Voltage Detector (AVD)	29
6.4.3 Low Power Modes	31
6.4.4 Register Description	32
7 INTERRUPTS	33
7.1 INTRODUCTION	33
7.2 MASKING AND PROCESSING FLOW	33
7.3 INTERRUPTS AND LOW POWER MODES	35
7.4 CONCURRENT & NESTED MANAGEMENT	35
7.5 INTERRUPT REGISTER DESCRIPTION	36
7.6 EXTERNAL INTERRUPTS	38
7.6.1 I/O Port Interrupt Sensitivity	38
7.7 EXTERNAL INTERRUPT CONTROL REGISTER (EICR)	40
8 POWER SAVING MODES	42
8.1 INTRODUCTION	42
8.2 SLOW MODE	42
8.3 WAIT MODE	43

Table of Contents

8.4	ACTIVE-HALT AND HALT MODES	44
8.4.1	ACTIVE-HALT MODE	44
8.4.2	HALT MODE	45
9	I/O PORTS	47
9.1	INTRODUCTION	47
9.2	FUNCTIONAL DESCRIPTION	47
9.2.1	Input Modes	47
9.2.2	Output Modes	47
9.2.3	Alternate Functions	47
9.3	I/O PORT IMPLEMENTATION	50
9.4	LOW POWER MODES	50
9.5	INTERRUPTS	50
9.5.1	I/O Port Implementation	51
10	ON-CHIP PERIPHERALS	53
10.1	WATCHDOG TIMER (WDG)	53
10.1.1	Introduction	53
10.1.2	Main Features	53
10.1.3	Functional Description	53
10.1.4	How to Program the Watchdog Timeout	54
10.1.5	Low Power Modes	56
10.1.6	Hardware Watchdog Option	56
10.1.7	Using Halt Mode with the WDG (WDGHALT option)	56
10.1.8	Interrupts	56
10.1.9	Register Description	56
10.2	MAIN CLOCK CONTROLLER WITH REAL TIME CLOCK AND BEEPER (MCC/RTC)	58
10.2.1	Programmable CPU Clock Prescaler	58
10.2.2	Clock-out Capability	58
10.2.3	Real Time Clock Timer (RTC)	58
10.2.4	Beeper	58
10.2.5	Low Power Modes	59
10.2.6	Interrupts	59
10.2.7	Register Description	59
10.3	PWM AUTO-RELOAD TIMER (ART)	61
10.3.1	Introduction	61
10.3.2	Functional Description	62
10.3.3	Register Description	66
10.4	16-BIT TIMER	70
10.4.1	Introduction	70
10.4.2	Main Features	70
10.4.3	Functional Description	70
10.4.4	Low Power Modes	82
10.4.5	Interrupts	82
10.4.6	Summary of Timer modes	82
10.4.7	Register Description	83
10.5	SERIAL PERIPHERAL INTERFACE (SPI)	89
10.5.1	Introduction	89
10.5.2	Main Features	89

Table of Contents

10.5.3	General Description	89
10.5.4	Clock Phase and Clock Polarity	93
10.5.5	Error Flags	94
10.5.6	Low Power Modes	96
10.5.7	Interrupts	96
10.5.8	Register Description	97
10.6	SERIAL COMMUNICATIONS INTERFACE (SCI)	100
10.6.1	Introduction	100
10.6.2	Main Features	100
10.6.3	General Description	100
10.6.4	Functional Description	102
10.6.5	Low Power Modes	109
10.6.6	Interrupts	109
10.6.7	Register Description	110
10.7	I2C BUS INTERFACE (I2C)	116
10.7.1	Introduction	116
10.7.2	Main Features	116
10.7.3	General Description	116
10.7.4	Functional Description	118
10.7.5	Low Power Modes	122
10.7.6	Interrupts	122
10.7.7	Register Description	123
10.8	CONTROLLER AREA NETWORK (CAN)	129
10.8.1	Introduction	129
10.8.2	Main Features	130
10.8.3	Functional Description	130
10.8.4	Register Description	136
10.8.5	List of CAN Cell Limitations	146
10.9	10-BIT A/D CONVERTER (ADC)	155
10.9.1	Introduction	155
10.9.2	Main Features	155
10.9.3	Functional Description	156
10.9.4	Low Power Modes	156
10.9.5	Interrupts	156
10.9.6	Register Description	157
11	INSTRUCTION SET	159
11.1	CPU ADDRESSING MODES	159
11.1.1	Inherent	160
11.1.2	Immediate	160
11.1.3	Direct	160
11.1.4	Indexed (No Offset, Short, Long)	160
11.1.5	Indirect (Short, Long)	160
11.1.6	Indirect Indexed (Short, Long)	161
11.1.7	Relative mode (Direct, Indirect)	161
11.2	INSTRUCTION GROUPS	162
12	ELECTRICAL CHARACTERISTICS	165
12.1	PARAMETER CONDITIONS	165

Table of Contents

12.1.1	Minimum and Maximum values	165
12.1.2	Typical values	165
12.1.3	Typical curves	165
12.1.4	Loading capacitor	165
12.1.5	Pin input voltage	165
12.2	ABSOLUTE MAXIMUM RATINGS	166
12.2.1	Voltage Characteristics	166
12.2.2	Current Characteristics	166
12.2.3	Thermal Characteristics	167
12.3	OPERATING CONDITIONS	167
12.3.1	General Operating Conditions	167
12.3.2	Operating Conditions with Low Voltage Detector (LVD)	168
12.3.3	Auxiliary Voltage Detector (AVD) Thresholds	168
12.3.4	External Voltage Detector (EVD) Thresholds	168
12.4	SUPPLY CURRENT CHARACTERISTICS	169
12.4.1	CURRENT CONSUMPTION	169
12.4.2	Supply and Clock Managers	171
12.4.3	On-Chip Peripherals	172
12.5	CLOCK AND TIMING CHARACTERISTICS	173
12.5.1	General Timings	173
12.5.2	External Clock Source	173
12.5.3	Crystal and Ceramic Resonator Oscillators	174
12.5.4	RC Oscillators	176
12.5.5	PLL Characteristics	177
12.6	MEMORY CHARACTERISTICS	178
12.6.1	RAM and Hardware Registers	178
12.6.2	FLASH Memory	178
12.7	EMC CHARACTERISTICS	179
12.7.1	Functional EMS (Electro Magnetic Susceptibility)	179
12.7.2	Electro Magnetic Interference (EMI)	180
12.7.3	Absolute Maximum Ratings (Electrical Sensitivity)	181
12.8	I/O PORT PIN CHARACTERISTICS	182
12.8.1	General Characteristics	182
12.8.2	Output Driving Current	183
12.9	CONTROL PIN CHARACTERISTICS	185
12.9.1	Asynchronous RESET Pin	185
12.9.2	ICCSEL/VPP Pin	187
12.10	TIMER PERIPHERAL CHARACTERISTICS	188
12.10.1	8-Bit PWM-ART Auto-Reload Timer	188
12.10.2	16-Bit Timer	188
12.11	COMMUNICATION INTERFACE CHARACTERISTICS	189
12.11.1	SPI - Serial Peripheral Interface	189
12.11.2	I2C - Inter IC Control Interface	191
12.11.3	CAN - Controller Area Network Interface	192
12.12	10-BIT ADC CHARACTERISTICS	193
12.12.1	Analog Power Supply and Reference Pins	195
12.12.2	General PCB Design Guidelines	195

Table of Contents

12.12.3 ADC Accuracy	196
13 PACKAGE CHARACTERISTICS	197
13.1 PACKAGE MECHANICAL DATA	197
13.2 THERMAL CHARACTERISTICS	199
13.3 SOLDERING INFORMATION	200
14 ST72521 DEVICE CONFIGURATION AND ORDERING INFORMATION	201
14.1 FLASH OPTION BYTES	201
14.2 DEVICE ORDERING INFORMATION AND TRANSFER OF CUSTOMER CODE	203
14.2.1 Version-Specific Sales Conditions	203
14.3 DEVELOPMENT TOOLS	206
14.3.1 Socket and Emulator Adapter Information	207
14.4 ST7 APPLICATION NOTES	208
15 KNOWN LIMITATIONS	211
15.1 ALL FLASH AND ROM DEVICES	211
15.1.1 External RC option	211
15.1.2 Safe Connection of OSC1/OSC2 Pins	211
15.1.3 Reset pin protection with LVD Enabled	211
15.1.4 Unexpected Reset Fetch	211
15.1.5 Clearing active interrupts outside interrupt routine	211
15.1.6 SCI Wrong Break duration	212
15.1.7 16-bit Timer PWM Mode	212
15.1.8 CAN Cell Limitations	212
15.1.9 I2C Multimaster	212
15.2 ALL FLASH DEVICES	213
15.2.1 Internal RC Oscillator with LVD	213
15.2.2 I/O behaviour during ICC mode entry sequence	213
15.2.3 Read-out protection with LVD	213
16 REVISION HISTORY	214

1 INTRODUCTION

The ST72F521 and ST72521B devices are members of the ST7 microcontroller family designed for mid-range applications with a CAN bus interface (Controller Area Network).

All devices are based on a common industry-standard 8-bit core, featuring an enhanced instruction set and are available with FLASH or ROM program memory.

Under software control, all devices can be placed in WAIT, SLOW, ACTIVE-HALT or HALT mode,

reducing power consumption when the application is in idle or stand-by state.

The enhanced instruction set and addressing modes of the ST7 offer both power and flexibility to software developers, enabling the design of highly efficient and compact application code. In addition to standard 8-bit data management, all ST7 microcontrollers feature true bit manipulation, 8x8 unsigned multiplication and indirect addressing modes.

Related Documentation

AN1131: Migrating applications from ST72511/311/314 to ST72521/321/324

Figure 1. Device Block Diagram

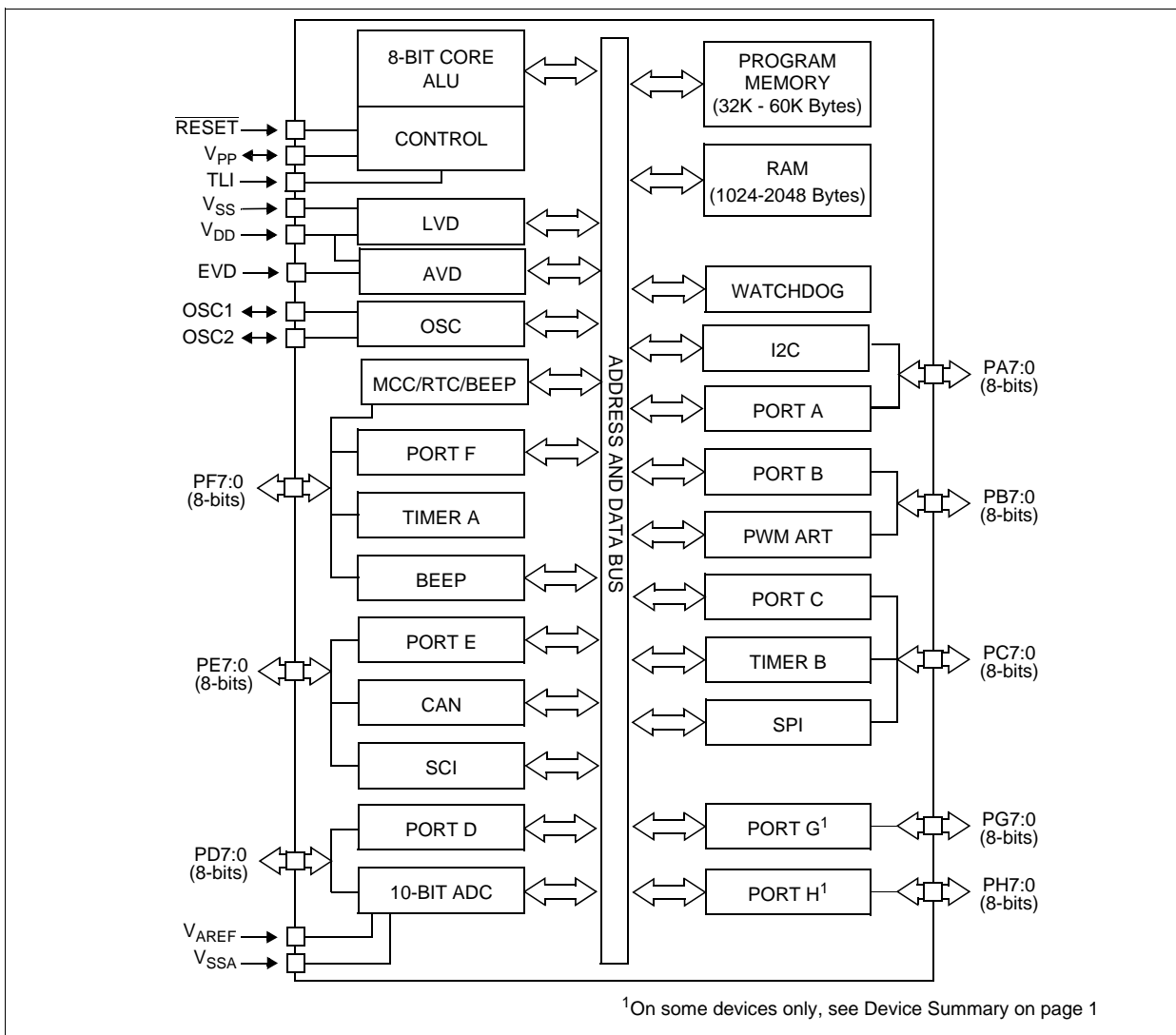

2 PIN DESCRIPTION

Figure 2. 80-Pin TQFP 14x14 Package Pinout

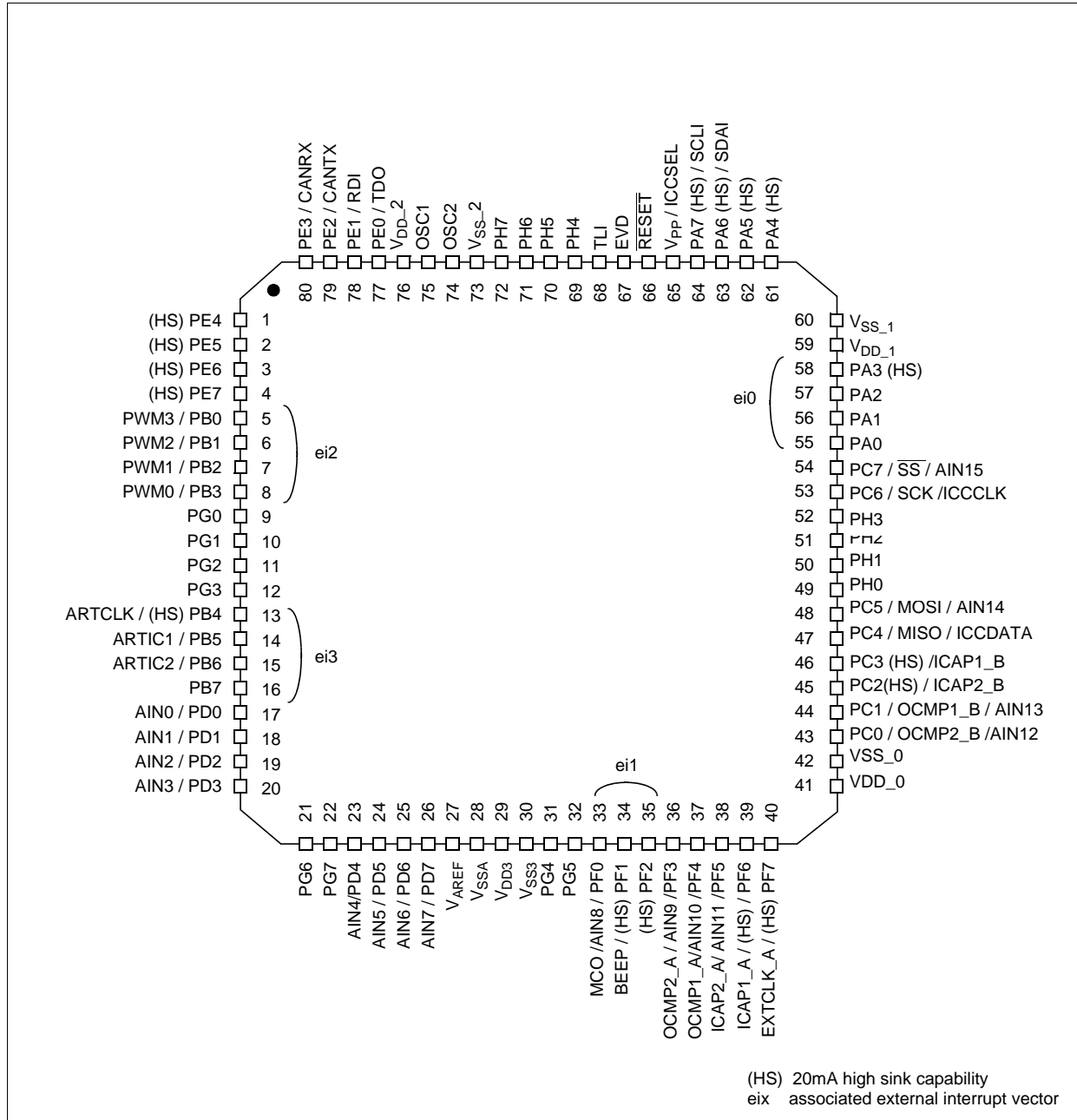

PIN DESCRIPTION (Cont'd)

Figure 3. 64-Pin TQFP 14x14 and 10x10 Package Pinout

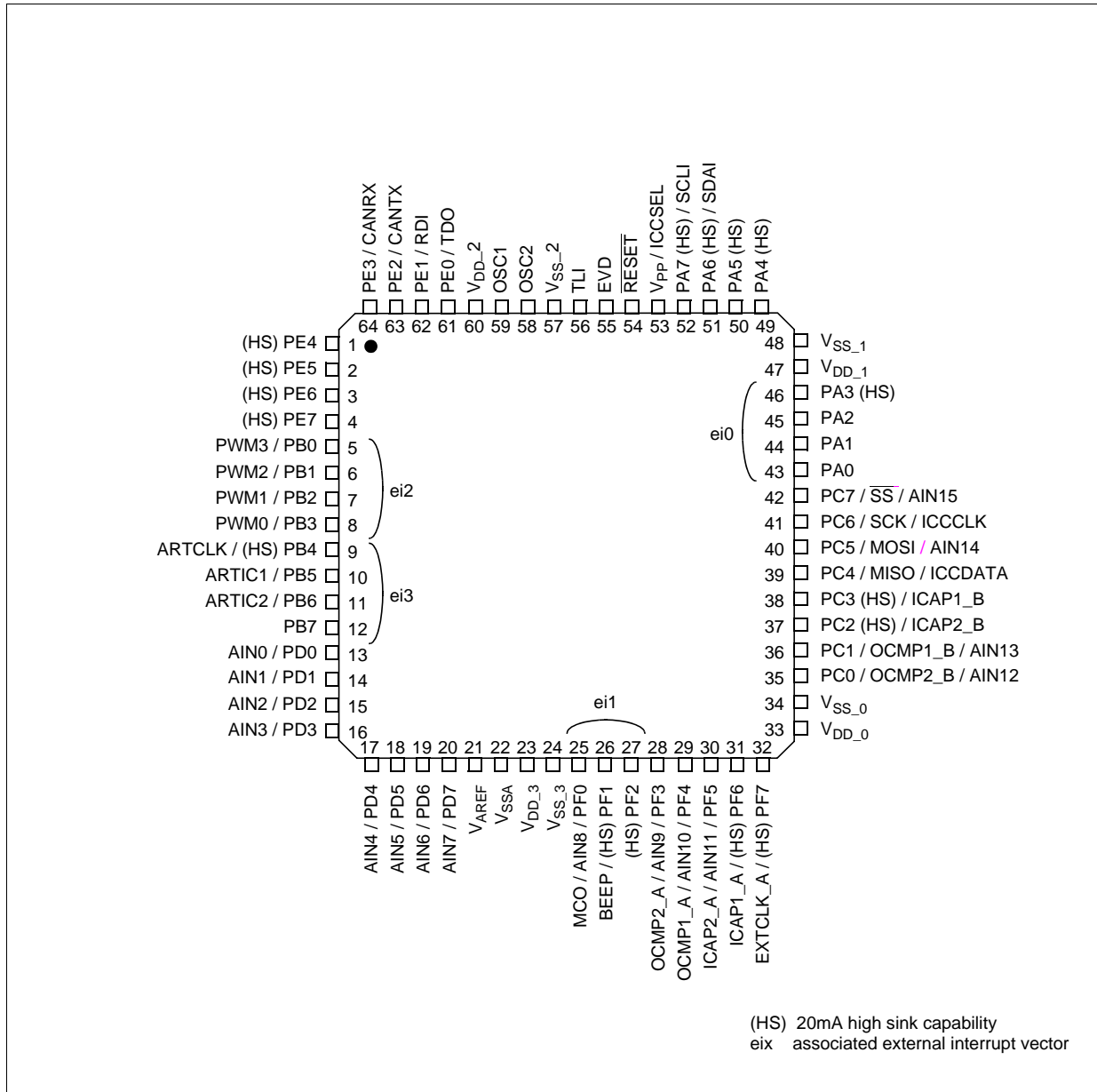

PIN DESCRIPTION (Cont'd)

For external pin connection guidelines, refer to See “ELECTRICAL CHARACTERISTICS” on page 165.

Legend / Abbreviations for Table 1:

Type: I = input, O = output, S = supply

Input level: A = Dedicated analog input

In/Output level: C = CMOS 0.3V_{DD}/0.7V_{DD}
 C_T = CMOS 0.3V_{DD}/0.7V_{DD} with input trigger
 T_T = TTL 0.8V / 2V with Schmitt trigger

Output level: HS = 20mA high sink (on N-buffer only)

Port and control configuration:

- Input: float = floating, wpu = weak pull-up, int = interrupt ¹⁾, ana = analog
- Output: OD = open drain ²⁾, PP = push-pull

Refer to “I/O PORTS” on page 47 for more details on the software configuration of the I/O ports.

The RESET configuration of each pin is shown in bold. This configuration is valid as long as the device is in reset state.

Table 1. Device Pin Description

Pin n°	TQFP80	TQFP64	Pin Name	Type	Level		Port						Main function (after reset)	Alternate function
					Input	Output	Input				Output			
							float	wpu	int	ana	OD	PP		
1	1		PE4 (HS)	I/O	C _T	HS	X	X			X	X	Port E4	
2	2		PE5 (HS)	I/O	C _T	HS	X	X			X	X	Port E5	
3	3		PE6 (HS)	I/O	C _T	HS	X	X			X	X	Port E6	
4	4		PE7 (HS)	I/O	C _T	HS	X	X			X	X	Port E7	
5	5		PB0/PWM3	I/O	C _T		X		ei2		X	X	Port B0	PWM Output 3
6	6		PB1/PWM2	I/O	C _T		X		ei2		X	X	Port B1	PWM Output 2
7	7		PB2/PWM1	I/O	C _T		X		ei2		X	X	Port B2	PWM Output 1
8	8		PB3/PWM0	I/O	C _T		X		ei2		X	X	Port B3	PWM Output 0
9	-		PG0	I/O	T _T		X	X			X	X	Port G0	
10	-		PG1	I/O	T _T		X	X			X	X	Port G1	
11	-		PG2	I/O	T _T		X	X			X	X	Port G2	
12	-		PG3	I/O	T _T		X	X			X	X	Port G3	
13	9		PB4 (HS)/ARTCLK	I/O	C _T	HS	X		ei3		X	X	Port B4	PWM-ART External Clock
14	10		PB5/ARTIC1	I/O	C _T		X		ei3		X	X	Port B5	PWM-ART Input Capture 1
15	11		PB6/ARTIC2	I/O	C _T		X		ei3		X	X	Port B6	PWM-ART Input Capture 2
16	12		PB7	I/O	C _T		X		ei3		X	X	Port B7	
17	13		PD0 /AIN0	I/O	C _T		X	X		X	X	X	Port D0	ADC Analog Input 0
18	14		PD1/AIN1	I/O	C _T		X	X		X	X	X	Port D1	ADC Analog Input 1
19	15		PD2/AIN2	I/O	C _T		X	X		X	X	X	Port D2	ADC Analog Input 2
20	16		PD3/AIN3	I/O	C _T		X	X		X	X	X	Port D3	ADC Analog Input 3
21	-		PG6	I/O	T _T		X	X			X	X	Port G6	
22	-		PG7	I/O	T _T		X	X			X	X	Port G7	
23	17		PD4/AIN4	I/O	C _T		X	X		X	X	X	Port D4	ADC Analog Input 4

Pin n°		Pin Name	Type	Level		Port						Main function (after reset)	Alternate function	
TQFP80	TQFP64			Input	Output	Input				Output				
						float	wpu	int	ana	OD	PP			
24	18	PD5/AIN5	I/O	C _T		X	X		X	X	X	Port D5	ADC Analog Input 5	
25	19	PD6/AIN6	I/O	C _T		X	X		X	X	X	Port D6	ADC Analog Input 6	
26	20	PD7/AIN7	I/O	C _T		X	X		X	X	X	Port D7	ADC Analog Input 7	
27	21	V _{AREF}	I									Analog Reference Voltage for ADC		
28	22	V _{SSA}	S									Analog Ground Voltage		
29	23	V _{DD_3}	S									Digital Main Supply Voltage		
30	24	V _{SS_3}	S									Digital Ground Voltage		
31	-	PG4	I/O	T _T		X	X			X	X	Port G4		
32	-	PG5	I/O	T _T		X	X			X	X	Port G5		
33	25	PF0/MCO/AIN8	I/O	C _T		X		ei1	X	X	X	Port F0	Main clock out (f _{CPU})	ADC Analog Input 8
34	26	PF1 (HS)/BEEP	I/O	C _T	HS	X		ei1		X	X	Port F1	Beep signal output	
35	27	PF2 (HS)	I/O	C _T	HS	X		ei1		X	X	Port F2		
36	28	PF3/OCMP2_A/AIN9	I/O	C _T		X	X		X	X	X	Port F3	Timer A Output Compare 2	ADC Analog Input 9
37	29	PF4/OCMP1_A/AIN10	I/O	C _T		X	X		X	X	X	Port F4	Timer A Output Compare 1	ADC Analog Input 10
38	30	PF5/ICAP2_A/AIN11	I/O	C _T		X	X		X	X	X	Port F5	Timer A Input Capture 2	ADC Analog Input 11
39	31	PF6 (HS)/ICAP1_A	I/O	C _T	HS	X	X			X	X	Port F6	Timer A Input Capture 1	
40	32	PF7 (HS)/EXTCLK_A	I/O	C _T	HS	X	X			X	X	Port F7	Timer A External Clock Source	
41	33	V _{DD_0}	S									Digital Main Supply Voltage		
42	34	V _{SS_0}	S									Digital Ground Voltage		
43	35	PC0/OCMP2_B/AIN12	I/O	C _T		X	X		X	X	X	Port C0	Timer B Output Compare 2	ADC Analog Input 12
44	36	PC1/OCMP1_B/AIN13	I/O	C _T		X	X		X	X	X	Port C1	Timer B Output Compare 1	ADC Analog Input 13
45	37	PC2 (HS)/ICAP2_B	I/O	C _T	HS	X	X			X	X	Port C2	Timer B Input Capture 2	
46	38	PC3 (HS)/ICAP1_B	I/O	C _T	HS	X	X			X	X	Port C3	Timer B Input Capture 1	
47	39	PC4/MISO/ICCDATA	I/O	C _T		X	X			X	X	Port C4	SPI Master In / Slave Out Data	ICC Data Input
48	40	PC5/MOSI/AIN14	I/O	C _T		X	X		X	X	X	Port C5	SPI Master Out / Slave In Data	ADC Analog Input 14
49	-	PH0	I/O	T _T		X	X			X	X	Port H0		
50	-	PH1	I/O	T _T		X	X			X	X	Port H1		
51	-	PH2	I/O	T _T		X	X			X	X	Port H2		

ST72F521, ST72521B

Pin n°		Pin Name	Type	Level		Port						Main function (after reset)	Alternate function	
TQFP80	TQFP64			Input	Output	Input				Output				
						float	wpu	int	ana	OD	PP			
52	-	PH3	I/O	T _T		X	X			X	X	Port H3		
53	41	PC6/SCK/ICCCLK	I/O	C _T		X	X			X	X	Port C6	SPI Serial Clock	ICC Clock Output
												Caution: Negative current injection not allowed on this pin ⁵⁾		
54	42	PC7/ \overline{SS} /AIN15	I/O	C _T		X	X		X	X	X	Port C7	SPI Slave Select (active low)	ADC Analog Input 15
55	43	PA0	I/O	C _T		X	ei0			X	X	Port A0		
56	44	PA1	I/O	C _T		X	ei0			X	X	Port A1		
57	45	PA2	I/O	C _T		X	ei0			X	X	Port A2		
58	46	PA3 (HS)	I/O	C _T	HS	X		ei0		X	X	Port A3		
59	47	V _{DD_1}	S									Digital Main Supply Voltage		
60	48	V _{SS_1}	S									Digital Ground Voltage		
61	49	PA4 (HS)	I/O	C _T	HS	X	X			X	X	Port A4		
62	50	PA5 (HS)	I/O	C _T	HS	X	X			X	X	Port A5		
63	51	PA6 (HS)/SDAI	I/O	C _T	HS	X				T		Port A6	I ² C Data ¹⁾	
64	52	PA7 (HS)/SCLI	I/O	C _T	HS	X				T		Port A7	I ² C Clock ¹⁾	
65	53	V _{pp} / ICCSEL	I									Must be tied low. In flash programming mode, this pin acts as the programming voltage input V _{pp} . See Section 12.9.2 for more details. High voltage must not be applied to ROM devices		
66	54	\overline{RESET}	I/O	C _T								Top priority non maskable interrupt.		
67	55	EVD										External voltage detector		
68	56	TLI	I	C _T		X		X				Top level interrupt input pin		
69	-	PH4	I/O	T _T		X	X			X	X	Port H4		
70	-	PH5	I/O	T _T		X	X			X	X	Port H5		
71	-	PH6	I/O	T _T		X	X			X	X	Port H6		
72	-	PH7	I/O	T _T		X	X			X	X	Port H7		
73	57	V _{SS_2}	S									Digital Ground Voltage		
74	58	OSC2 ³⁾	I/O									Resonator oscillator inverter output		
75	59	OSC1 ³⁾	I									External clock input or Resonator oscillator inverter input		
76	60	V _{DD_2}	S									Digital Main Supply Voltage		
77	61	PE0/TDO	I/O	C _T		X	X			X	X	Port E0	SCI Transmit Data Out	
78	62	PE1/RDI	I/O	C _T		X	X			X	X	Port E1	SCI Receive Data In	
79	63	PE2/CANTX	I/O	C _T			X					Port E2	CAN Transmit Data Output	
80	64	PE3/CANRX	I/O	C _T		X	X			X	X	Port E3	CAN Receive Data Input	

Notes:

1. In the interrupt input column, “eiX” defines the associated external interrupt vector. If the weak pull-up

column (wpu) is merged with the interrupt column (int), then the I/O configuration is pull-up interrupt input, else the configuration is floating interrupt input.

2. In the open drain output column, "T" defines a true open drain I/O (P-Buffer and protection diode to V_{DD} are not implemented). See "I/O PORTS" on page 47. and [Section 12.8 I/O PORT PIN CHARACTERISTICS](#) for more details.

3. OSC1 and OSC2 pins connect a crystal/ceramic resonator, or an external source to the on-chip oscillator; see [Section 1 INTRODUCTION](#) and [Section 12.5 CLOCK AND TIMING CHARACTERISTICS](#) for more details.

4. On the chip, each I/O port may have up to 8 pads. Pads that are not bonded to external pins are in input pull-up configuration after reset. The configuration of these pads must be kept at reset state to avoid added current consumption.

3 REGISTER & MEMORY MAP

As shown in [Figure 4](#), the MCU is capable of addressing 64K bytes of memories and I/O registers. The available memory locations consist of 128 bytes of register locations, up to 2Kbytes of RAM and up to 60Kbytes of user program memory. The RAM space includes up to 256 bytes for the stack from 0100h to 01FFh.

The highest address bytes contain the user reset and interrupt vectors.

IMPORTANT: Memory locations marked as “Reserved” must never be accessed. Accessing a reserved area can have unpredictable effects on the device.

Related Documentation

AN 985: Executing Code in ST7 RAM

Figure 4. Memory Map

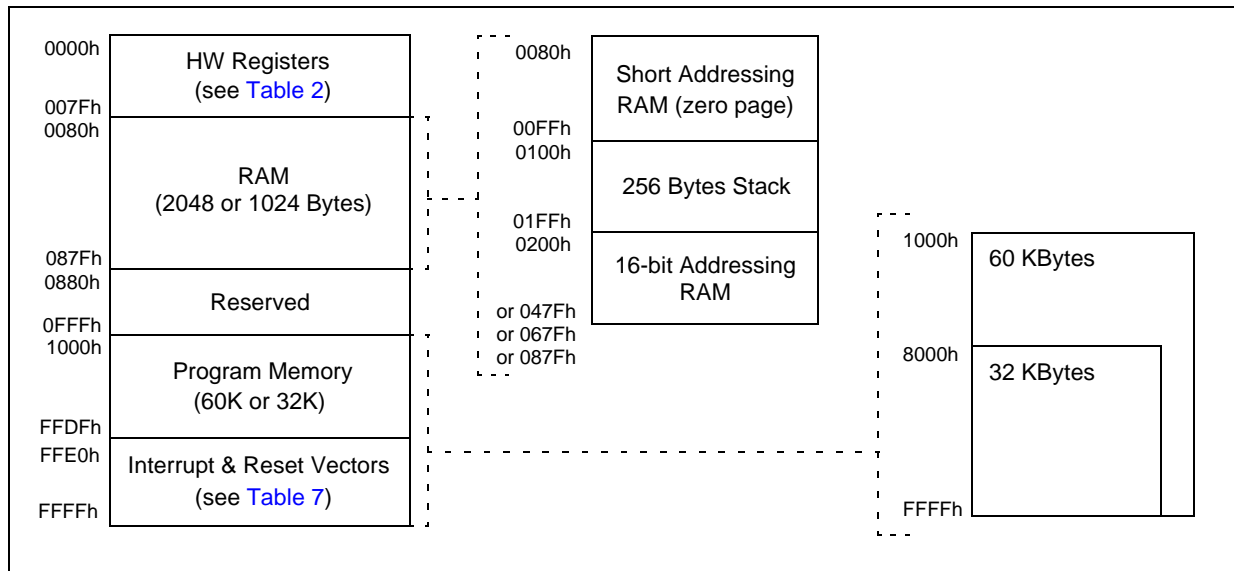

Table 2. Hardware Register Map

Address	Block	Register Label	Register Name	Reset Status	Remarks
0000h 0001h 0002h	Port A	PADR PADDR PAOR	Port A Data Register Port A Data Direction Register Port A Option Register	00h ¹⁾ 00h 00h	R/W R/W R/W
0003h 0004h 0005h	Port B	PBDR PBDDR PBOR	Port B Data Register Port B Data Direction Register Port B Option Register	00h ¹⁾ 00h 00h	R/W R/W R/W
0006h 0007h 0008h	Port C	PCDR PCDDR PCOR	Port C Data Register Port C Data Direction Register Port C Option Register	00h ¹⁾ 00h 00h	R/W R/W R/W
0009h 000Ah 000Bh	Port D	PDDR PDDDR PDOR	Port D Data Register Port D Data Direction Register Port D Option Register	00h ¹⁾ 00h 00h	R/W R/W R/W
000Ch 000Dh 000Eh	Port E	PEDR PEDDR PEOR	Port E Data Register Port E Data Direction Register Port E Option Register	00h ¹⁾ 00h 00h	R/W R/W ²⁾ R/W ²⁾
000Fh 0010h 0011h	Port F	PFDR PFDDR PFOR	Port F Data Register Port F Data Direction Register Port F Option Register	00h ¹⁾ 00h 00h	R/W R/W R/W
0012h 0013h 0014h	Port G ²⁾	PGDR PGDDR PGOR	Port G Data Register Port G Data Direction Register Port G Option Register	00h ¹⁾ 00h 00h	R/W R/W R/W
0015h 0016h 0017h	Port H ²⁾	PHDR PHDDR PHOR	Port H Data Register Port H Data Direction Register Port H Option Register	00h ¹⁾ 00h 00h	R/W R/W R/W
0018h 0019h 001Ah 001Bh 001Ch 001Dh 001Eh	I ² C	I2CCR I2CSR1 I2CSR2 I2CCCR I2COAR1 I2COAR2 I2CDR	I ² C Control Register I ² C Status Register 1 I ² C Status Register 2 I ² C Clock Control Register I ² C Own Address Register 1 I ² C Own Address Register2 I ² C Data Register	00h 00h 00h 00h 00h 00h 00h	R/W Read Only Read Only R/W R/W R/W R/W
001Fh 0020h	Reserved Area (2 Bytes)				
0021h 0022h 0023h	SPI	SPIDR SPICR SPICSR	SPI Data I/O Register SPI Control Register SPI Control/Status Register	xxh 0xh 00h	R/W R/W R/W

ST72F521, ST72521B

Address	Block	Register Label	Register Name	Reset Status	Remarks
0024h 0025h 0026h 0027h	ITC	ISPR0	Interrupt Software Priority Register 0	FFh	R/W
		ISPR1	Interrupt Software Priority Register 1	FFh	R/W
		ISPR2	Interrupt Software Priority Register 2	FFh	R/W
		ISPR3	Interrupt Software Priority Register 3	FFh	R/W
0028h		EICR	External Interrupt Control Register	00h	R/W
0029h	FLASH	FCSR	Flash Control/Status Register	00h	R/W
002Ah	WATCHDOG	WDGCR	Watchdog Control Register	7Fh	R/W
002Bh		SICSR	System Integrity Control/Status Register	000x 000x b	R/W
002Ch 002Dh	MCC	MCCSR	Main Clock Control / Status Register	00h	R/W
		MCCBCR	Main Clock Controller: Beep Control Register	00h	R/W
002Eh to 0030h	Reserved Area (3 Bytes)				
0031h 0032h 0033h 0034h 0035h 0036h 0037h 0038h 0039h 003Ah 003Bh 003Ch 003Dh 003Eh 003Fh	TIMER A	TACR2	Timer A Control Register 2	00h	R/W
		TACR1	Timer A Control Register 1	00h	R/W
		TACSR	Timer A Control/Status Register	xxxx x0xx b	R/W
		TAIC1HR	Timer A Input Capture 1 High Register	xxh	Read Only
		TAIC1LR	Timer A Input Capture 1 Low Register	xxh	Read Only
		TAOC1HR	Timer A Output Compare 1 High Register	80h	R/W
		TAOC1LR	Timer A Output Compare 1 Low Register	00h	R/W
		TACHR	Timer A Counter High Register	FFh	Read Only
		TACL	Timer A Counter Low Register	FCh	Read Only
		TAACHR	Timer A Alternate Counter High Register	FFh	Read Only
		TAACLR	Timer A Alternate Counter Low Register	FCh	Read Only
		TAIC2HR	Timer A Input Capture 2 High Register	xxh	Read Only
		TAIC2LR	Timer A Input Capture 2 Low Register	xxh	Read Only
		TAOC2HR	Timer A Output Compare 2 High Register	80h	R/W
	TAOC2LR	Timer A Output Compare 2 Low Register	00h	R/W	
0040h	Reserved Area (1 Byte)				
0041h 0042h 0043h 0044h 0045h 0046h 0047h 0048h 0049h 004Ah 004Bh 004Ch 004Dh 004Eh 004Fh	TIMER B	TBCR2	Timer B Control Register 2	00h	R/W
		TBCR1	Timer B Control Register 1	00h	R/W
		TBCSR	Timer B Control/Status Register	xxxx x0xx b	R/W
		TBIC1HR	Timer B Input Capture 1 High Register	xxh	Read Only
		TBIC1LR	Timer B Input Capture 1 Low Register	xxh	Read Only
		TBOC1HR	Timer B Output Compare 1 High Register	80h	R/W
		TBOC1LR	Timer B Output Compare 1 Low Register	00h	R/W
		TBCHR	Timer B Counter High Register	FFh	Read Only
		TBCLR	Timer B Counter Low Register	FCh	Read Only
		TBACHR	Timer B Alternate Counter High Register	FFh	Read Only
		TBACLR	Timer B Alternate Counter Low Register	FCh	Read Only
		TBIC2HR	Timer B Input Capture 2 High Register	xxh	Read Only
		TBIC2LR	Timer B Input Capture 2 Low Register	xxh	Read Only
		TBOC2HR	Timer B Output Compare 2 High Register	80h	R/W
	TBOC2LR	Timer B Output Compare 2 Low Register	00h	R/W	

Address	Block	Register Label	Register Name	Reset Status	Remarks
0050h 0051h 0052h 0053h 0054h 0055h 0056h 0057h	SCI	SCISR	SCI Status Register	C0h	Read Only
		SCIDR	SCI Data Register	xxh	R/W
		SCIBRR	SCI Baud Rate Register	00h	R/W
		SCICR1	SCI Control Register 1	x000 0000b	R/W
		SCICR2	SCI Control Register 2	00h	R/W
		SCIERPR	SCI Extended Receive Prescaler Register	00h	R/W
			Reserved area	---	
		SCIETPR	SCI Extended Transmit Prescaler Register	00h	R/W
0058h 0059h	Reserved Area (2 Bytes)				
005Ah 005Bh 005Ch 005Dh 005Eh 005Fh 0060h to 006Fh	CAN	CANISR	CAN Interrupt Status Register	00h	R/W
		CANICR	CAN Interrupt Control Register	00h	R/W
		CANCSR	CAN Control / Status Register	00h	R/W
		CANBRPR	CAN Baud Rate Prescaler Register	00h	R/W
		CANBTR	CAN Bit Timing Register	23h	R/W
		CANPSR	CAN Page Selection Register	00h	R/W
			First address to Last address of CAN page x	--	See CAN Description
0070h 0071h 0072h	ADC	ADCCSR	Control/Status Register	00h	R/W
		ADCDRH	Data High Register	00h	Read Only
		ADCRL	Data Low Register	00h	Read Only
0073h 0074h 0075h 0076h 0077h 0078h 0079h 007Ah 007Bh 007Ch 007Dh	PWM ART	PWMDCR3	PWM AR Timer Duty Cycle Register 3	00h	R/W
		PWMDCR2	PWM AR Timer Duty Cycle Register 2	00h	R/W
		PWMDCR1	PWM AR Timer Duty Cycle Register 1	00h	R/W
		PWMDCR0	PWM AR Timer Duty Cycle Register 0	00h	R/W
		PWMCR	PWM AR Timer Control Register	00h	R/W
		ARTCSR	Auto-Reload Timer Control/Status Register	00h	R/W
		ARTCAR	Auto-Reload Timer Counter Access Register	00h	R/W
		ARTARR	Auto-Reload Timer Auto-Reload Register	00h	R/W
		ARTICCSR	AR Timer Input Capture Control/Status Reg.	00h	R/W
		ARTICR1	AR Timer Input Capture Register 1	00h	Read Only
	ARTICR2	AR Timer Input Capture Register 1	00h	Read Only	
007Eh 007Fh	Reserved Area (2 Bytes)				

Legend: x=undefined, R/W=read/write

Notes:

1. The contents of the I/O port DR registers are readable only in output configuration. In input configuration, the values of the I/O pins are returned instead of the DR register contents.
2. The bits associated with unavailable pins must always keep their reset value.

4 FLASH PROGRAM MEMORY

4.1 Introduction

The ST7 dual voltage High Density Flash (HDFlash) is a non-volatile memory that can be electrically erased as a single block or by individual sectors and programmed on a Byte-by-Byte basis using an external V_{PP} supply.

The HDFlash devices can be programmed and erased off-board (plugged in a programming tool) or on-board using ICP (In-Circuit Programming) or IAP (In-Application Programming).

The array matrix organisation allows each sector to be erased and reprogrammed without affecting other sectors.

4.2 Main Features

- Three Flash programming modes:
 - Insertion in a programming tool. In this mode, all sectors including option bytes can be programmed or erased.
 - ICP (In-Circuit Programming). In this mode, all sectors including option bytes can be programmed or erased without removing the device from the application board.
 - IAP (In-Application Programming). In this mode, all sectors except Sector 0, can be programmed or erased without removing the device from the application board and while the application is running.
- ICT (In-Circuit Testing) for downloading and executing user application test patterns in RAM
- Read-out protection
- Register Access Security System (RASS) to prevent accidental programming or erasing

4.3 Structure

The Flash memory is organised in sectors and can be used for both code and data storage.

Depending on the overall Flash memory size in the microcontroller device, there are up to three user

sectors (see Table 3). Each of these sectors can be erased independently to avoid unnecessary erasing of the whole Flash memory when only a partial erasing is required.

The first two sectors have a fixed size of 4 Kbytes (see Figure 5). They are mapped in the upper part of the ST7 addressing space so the reset and interrupt vectors are located in Sector 0 (F000h-FFFFh).

Table 3. Sectors available in Flash devices

Flash Size (bytes)	Available Sectors
4K	Sector 0
8K	Sectors 0,1
> 8K	Sectors 0,1, 2

4.3.1 Read-out Protection

Read-out protection, when selected, provides a protection against Program Memory content extraction and against write access to Flash memory. Even if no protection can be considered as totally unbreakable, the feature provides a very high level of protection for a general purpose microcontroller.

In flash devices, this protection is removed by reprogramming the option. In this case, the entire program memory is first automatically erased and the device can be reprogrammed.

Read-out protection selection depends on the device type:

- In Flash devices it is enabled and removed through the FMP_R bit in the option byte.
- In ROM devices it is enabled by mask option specified in the Option List.

Note: In flash devices, the LVD is not supported if read-out protection is enabled.

Figure 5. Memory Map and Sector Address

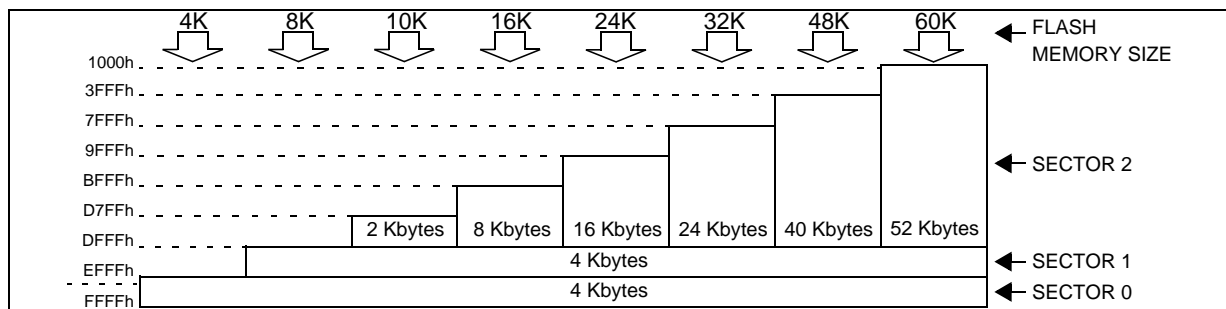

FLASH PROGRAM MEMORY (Cont'd)

4.4 ICC Interface

ICC needs a minimum of 4 and up to 6 pins to be connected to the programming tool (see Figure 6). These pins are:

- $\overline{\text{RESET}}$: device reset
- V_{SS} : device power supply ground
- ICCCLK: ICC output serial clock pin
- ICCDATA: ICC input/output serial data pin
- ICCSEL/ V_{PP} : programming voltage
- OSC1(or OSCIN): main clock input for external source (optional)
- V_{DD} : application board power supply (optional, see Figure 6, Note 3)

Figure 6. Typical ICC Interface

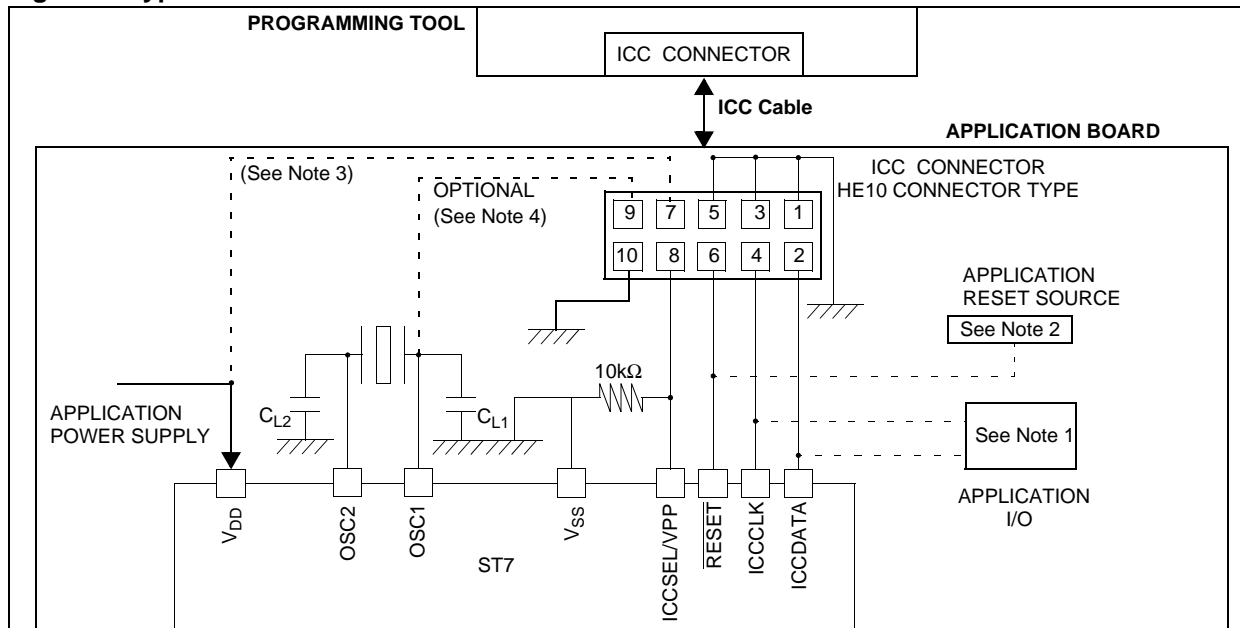

Notes:

1. If the ICCCLK or ICCDATA pins are only used as outputs in the application, no signal isolation is necessary. As soon as the Programming Tool is plugged to the board, even if an ICC session is not in progress, the ICCCLK and ICCDATA pins are not available for the application. If they are used as inputs by the application, isolation such as a serial resistor has to be implemented in case another device forces the signal. Refer to the Programming Tool documentation for recommended resistor values.
2. During the ICC session, the programming tool must control the $\overline{\text{RESET}}$ pin. This can lead to conflicts between the programming tool and the application reset circuit if it drives more than 5mA at high level (push pull output or pull-up resistor < 1K). A schottky diode can be used to isolate the application RESET circuit in this case. When using a classical RC network with R > 1K or a reset man-

agement IC with open drain output and pull-up resistor > 1K, no additional components are needed. In all cases the user must ensure that no external reset is generated by the application during the ICC session.

3. The use of Pin 7 of the ICC connector depends on the Programming Tool architecture. This pin must be connected when using most ST Programming Tools (it is used to monitor the application power supply). Please refer to the Programming Tool manual.

4. Pin 9 has to be connected to the OSC1 or OSCIN pin of the ST7 when the clock is not available in the application or if the selected clock option is not programmed in the option byte. ST7 devices with multi-oscillator capability need to have OSC2 grounded in this case.

FLASH PROGRAM MEMORY (Cont'd)

4.5 ICP (In-Circuit Programming)

To perform ICP the microcontroller must be switched to ICC (In-Circuit Communication) mode by an external controller or programming tool.

Depending on the ICP code downloaded in RAM, Flash memory programming can be fully customized (number of bytes to program, program locations, or selection serial communication interface for downloading).

When using an STMicroelectronics or third-party programming tool that supports ICP and the specific microcontroller device, the user needs only to implement the ICP hardware interface on the application board (see [Figure 6](#)). For more details on the pin locations, refer to the device pinout description.

4.6 IAP (In-Application Programming)

This mode uses a BootLoader program previously stored in Sector 0 by the user (in ICP mode or by plugging the device in a programming tool).

This mode is fully controlled by user software. This allows it to be adapted to the user application, (user-defined strategy for entering programming mode, choice of communications protocol used to fetch the data to be stored, etc.). For example, it is

possible to download code from the SPI, SCI, USB or CAN interface and program it in the Flash. IAP mode can be used to program any of the Flash sectors except Sector 0, which is write/erase protected to allow recovery in case errors occur during the programming operation.

4.7 Related Documentation

For details on Flash programming and ICC protocol, refer to the ST7 Flash Programming Reference Manual and to the ST7 ICC Protocol Reference Manual.

4.7.1 Register Description

FLASH CONTROL/STATUS REGISTER (FCSR)

Read/Write

Reset Value: 0000 0000 (00h)

7								0
0	0	0	0	0	0	0	0	0

This register is reserved for use by Programming Tool software. It controls the Flash programming and erasing operations.

Figure 7. Flash Control/Status Register Address and Reset Value

Address (Hex.)	Register Label	7	6	5	4	3	2	1	0
0029h	FCSR Reset Value	0	0	0	0	0	0	0	0

5 CENTRAL PROCESSING UNIT

5.1 INTRODUCTION

This CPU has a full 8-bit architecture and contains six internal registers allowing efficient 8-bit data manipulation.

5.2 MAIN FEATURES

- Enable executing 63 basic instructions
- Fast 8-bit by 8-bit multiply
- 17 main addressing modes (with indirect addressing mode)
- Two 8-bit index registers
- 16-bit stack pointer
- Low power HALT and WAIT modes
- Priority maskable hardware interrupts
- Non-maskable software/hardware interrupts

5.3 CPU REGISTERS

The 6 CPU registers shown in [Figure 8](#) are not present in the memory mapping and are accessed by specific instructions.

Accumulator (A)

The Accumulator is an 8-bit general purpose register used to hold operands and the results of the arithmetic and logic calculations and to manipulate data.

Index Registers (X and Y)

These 8-bit registers are used to create effective addresses or as temporary storage areas for data manipulation. (The Cross-Assembler generates a precede instruction (PRE) to indicate that the following instruction refers to the Y register.)

The Y register is not affected by the interrupt automatic procedures.

Program Counter (PC)

The program counter is a 16-bit register containing the address of the next instruction to be executed by the CPU. It is made of two 8-bit registers PCH (Program Counter Low which is the LSB) and PCH (Program Counter High which is the MSB).

Figure 8. CPU Registers

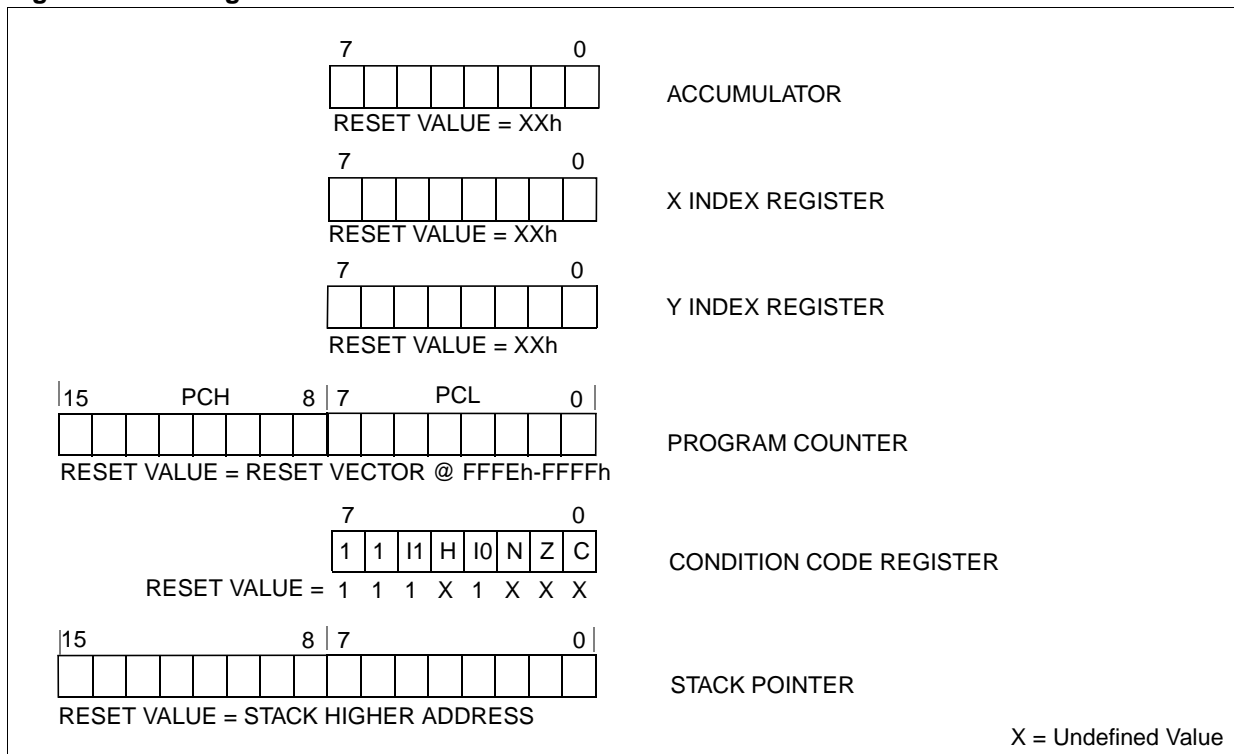

CENTRAL PROCESSING UNIT (Cont'd)

Condition Code Register (CC)

Read/Write

Reset Value: 111x1xxx

7							0
1	1	I1	H	I0	N	Z	C

The 8-bit Condition Code register contains the interrupt masks and four flags representative of the result of the instruction just executed. This register can also be handled by the PUSH and POP instructions.

These bits can be individually tested and/or controlled by specific instructions.

Arithmetic Management Bits

Bit 4 = **H** *Half carry*.

This bit is set by hardware when a carry occurs between bits 3 and 4 of the ALU during an ADD or ADC instructions. It is reset by hardware during the same instructions.

- 0: No half carry has occurred.
- 1: A half carry has occurred.

This bit is tested using the JRH or JRNH instruction. The H bit is useful in BCD arithmetic subroutines.

Bit 2 = **N** *Negative*.

This bit is set and cleared by hardware. It is representative of the result sign of the last arithmetic, logical or data manipulation. It's a copy of the result 7th bit.

- 0: The result of the last operation is positive or null.
- 1: The result of the last operation is negative (i.e. the most significant bit is a logic 1).

This bit is accessed by the JRMI and JRPL instructions.

Bit 1 = **Z** *Zero*.

This bit is set and cleared by hardware. This bit indicates that the result of the last arithmetic, logical or data manipulation is zero.

- 0: The result of the last operation is different from zero.
- 1: The result of the last operation is zero.

This bit is accessed by the JREQ and JRNE test instructions.

Bit 0 = **C** *Carry/borrow*.

This bit is set and cleared by hardware and software. It indicates an overflow or an underflow has occurred during the last arithmetic operation.

- 0: No overflow or underflow has occurred.
- 1: An overflow or underflow has occurred.

This bit is driven by the SCF and RCF instructions and tested by the JRC and JRNC instructions. It is also affected by the "bit test and branch", shift and rotate instructions.

Interrupt Management Bits

Bit 5,3 = **I1, I0** *Interrupt*

The combination of the I1 and I0 bits gives the current interrupt software priority.

Interrupt Software Priority	I1	I0
Level 0 (main)	1	0
Level 1	0	1
Level 2	0	0
Level 3 (= interrupt disable)	1	1

These two bits are set/cleared by hardware when entering in interrupt. The loaded value is given by the corresponding bits in the interrupt software priority registers (IxSPR). They can be also set/cleared by software with the RIM, SIM, IRET, HALT, WFI and PUSH/POP instructions.

See the interrupt management chapter for more details.

CENTRAL PROCESSING UNIT (Cont'd)

Stack Pointer (SP)

Read/Write
Reset Value: 01 FFh

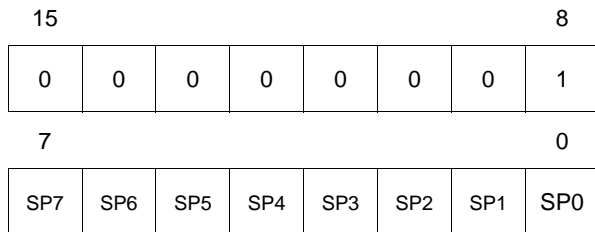

The Stack Pointer is a 16-bit register which is always pointing to the next free location in the stack. It is then decremented after data has been pushed onto the stack and incremented before data is popped from the stack (see Figure 9).

Since the stack is 256 bytes deep, the 8 most significant bits are forced by hardware. Following an MCU Reset, or after a Reset Stack Pointer instruction (RSP), the Stack Pointer contains its reset value (the SP7 to SP0 bits are set) which is the stack higher address.

The least significant byte of the Stack Pointer (called S) can be directly accessed by a LD instruction.

Note: When the lower limit is exceeded, the Stack Pointer wraps around to the stack upper limit, without indicating the stack overflow. The previously stored information is then overwritten and therefore lost. The stack also wraps in case of an underflow.

The stack is used to save the return address during a subroutine call and the CPU context during an interrupt. The user may also directly manipulate the stack by means of the PUSH and POP instructions. In the case of an interrupt, the PCL is stored at the first location pointed to by the SP. Then the other registers are stored in the next locations as shown in Figure 9.

- When an interrupt is received, the SP is decremented and the context is pushed on the stack.
- On return from interrupt, the SP is incremented and the context is popped from the stack.

A subroutine call occupies two locations and an interrupt five locations in the stack area.

Figure 9. Stack Manipulation Example

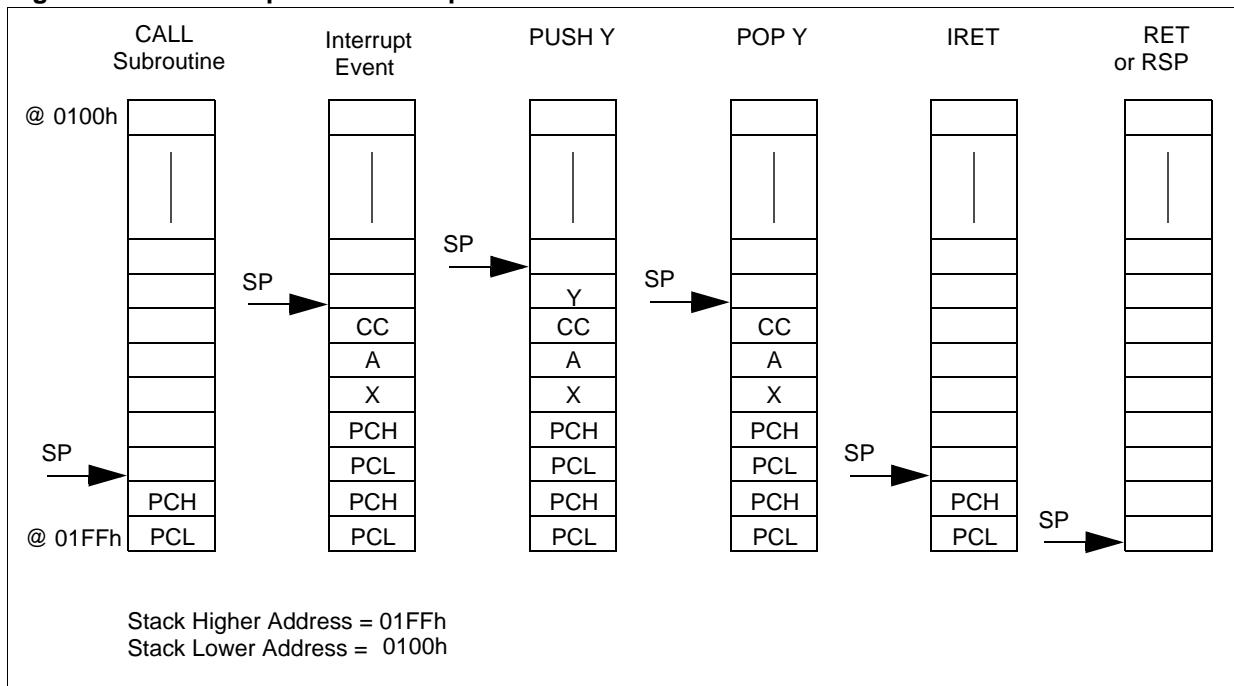

6 SUPPLY, RESET AND CLOCK MANAGEMENT

The device includes a range of utility features for securing the application in critical situations (for example in case of a power brown-out), and reducing the number of external components. An overview is shown in Figure 11.

For more details, refer to dedicated parametric section.

Main features

- Optional PLL for multiplying the frequency by 2 (not to be used with internal RC oscillator)
- Reset Sequence Manager (RSM)
- Multi-Oscillator Clock Management (MO)
 - 5 Crystal/Ceramic resonator oscillators
 - 1 Internal RC oscillator
- System Integrity Management (SI)
 - Main supply Low voltage detection (LVD)
 - Auxiliary Voltage detector (AVD) with interrupt capability for monitoring the main supply or the EVD pin

6.1 PHASE LOCKED LOOP

If the clock frequency input to the PLL is in the range 2 to 4 MHz, the PLL can be used to multiply the frequency by two to obtain an f_{OSC2} of 4 to 8 MHz. The PLL is enabled by option byte. If the PLL is disabled, then $f_{OSC2} = f_{OSC}/2$.

Caution: The PLL is not recommended for applications where timing accuracy is required. See “PLL Characteristics” on page 177.

Figure 10. PLL Block Diagram

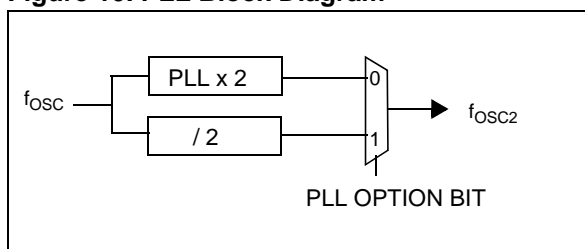
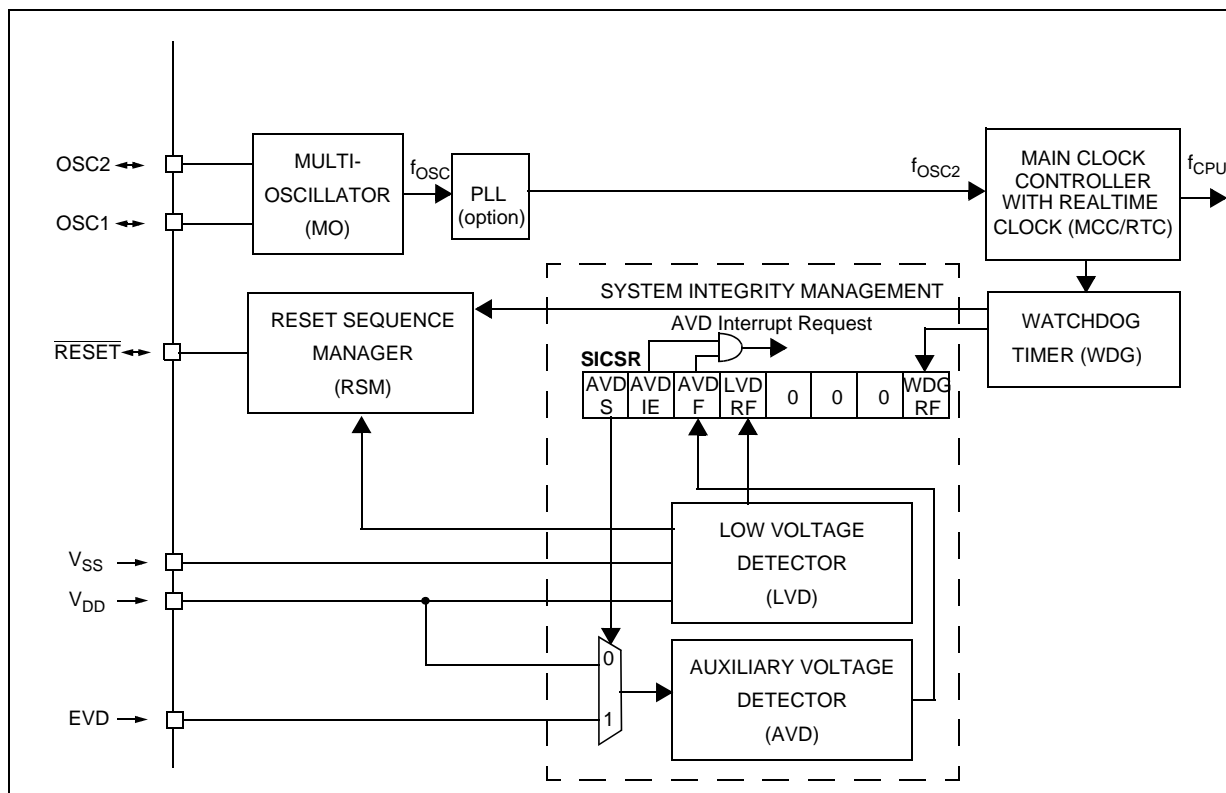

Figure 11. Clock, Reset and Supply Block Diagram



6.2 MULTI-OSCILLATOR (MO)

The main clock of the ST7 can be generated by three different source types coming from the multi-oscillator block:

- an external source
- 4 crystal or ceramic resonator oscillators
- an internal high frequency RC oscillator

Each oscillator is optimized for a given frequency range in terms of consumption and is selectable through the option byte. The associated hardware configurations are shown in [Table 4](#). Refer to the electrical characteristics section for more details.

Caution: The OSC1 and/or OSC2 pins must not be left unconnected. For the purposes of Failure Mode and Effect Analysis, it should be noted that if the OSC1 and/or OSC2 pins are left unconnected, the ST7 main oscillator may start and, in this configuration, could generate an f_{OSC} clock frequency in excess of the allowed maximum (>16MHz.), putting the ST7 in an unsafe/undefined state. The product behaviour must therefore be considered undefined when the OSC pins are left unconnected.

External Clock Source

In this external clock mode, a clock signal (square, sinus or triangle) with ~50% duty cycle has to drive the OSC1 pin while the OSC2 pin is tied to ground.

Crystal/Ceramic Oscillators

This family of oscillators has the advantage of producing a very accurate rate on the main clock of the ST7. The selection within a list of 4 oscillators with different frequency ranges has to be done by option byte in order to reduce consumption (refer to [section 14.1 on page 201](#) for more details on the frequency ranges). In this mode of the multi-oscillator, the resonator and the load capacitors have to be placed as close as possible to the oscillator pins in order to minimize output distortion and start-up stabilization time. The loading capacitance values must be adjusted according to the selected oscillator.

These oscillators are not stopped during the RESET phase to avoid losing time in the oscillator start-up phase.

Internal RC Oscillator

This oscillator allows a low cost solution for the main clock of the ST7 using only an internal resistor and capacitor. Internal RC oscillator mode has the drawback of a lower frequency accuracy and should not be used in applications that require accurate timing.

In this mode, the two oscillator pins have to be tied to ground.

Table 4. ST7 Clock Sources

	Hardware Configuration
External Clock	
Crystal/Ceramic Resonators	
Internal RC Oscillator	

6.3 RESET SEQUENCE MANAGER (RSM)

6.3.1 Introduction

The reset sequence manager includes three RESET sources as shown in Figure 13:

- External $\overline{\text{RESET}}$ source pulse
- Internal LVD RESET (Low Voltage Detection)
- Internal WATCHDOG RESET

These sources act on the $\overline{\text{RESET}}$ pin and it is always kept low during the delay phase.

The RESET service routine vector is fixed at addresses FFFEh-FFFFh in the ST7 memory map.

The basic RESET sequence consists of 3 phases as shown in Figure 12:

- Active Phase depending on the RESET source
- 256 or 4096 CPU clock cycle delay (selected by option byte)
- RESET vector fetch

The 256 or 4096 CPU clock cycle delay allows the oscillator to stabilise and ensures that recovery has taken place from the Reset state. The shorter or longer clock cycle delay should be selected by option byte to correspond to the stabilization time of the external oscillator used in the application (see section 14.1 on page 201).

The RESET vector fetch phase duration is 2 clock cycles.

Figure 12. RESET Sequence Phases

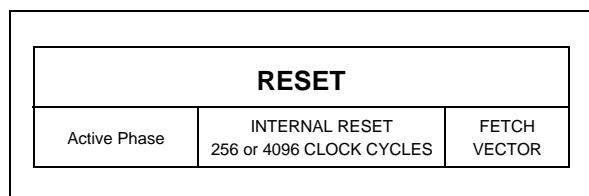

6.3.2 Asynchronous External $\overline{\text{RESET}}$ pin

The $\overline{\text{RESET}}$ pin is both an input and an open-drain output with integrated R_{ON} weak pull-up resistor. This pull-up has no fixed value but varies in accordance with the input voltage. It can be pulled low by external circuitry to reset the device. See "CONTROL PIN CHARACTERISTICS" on page 185 for more details.

A RESET signal originating from an external source must have a duration of at least $t_{h(RSTL)in}$ in order to be recognized (see Figure 14). This detection is asynchronous and therefore the MCU can enter reset state even in HALT mode.

Figure 13. Reset Block Diagram

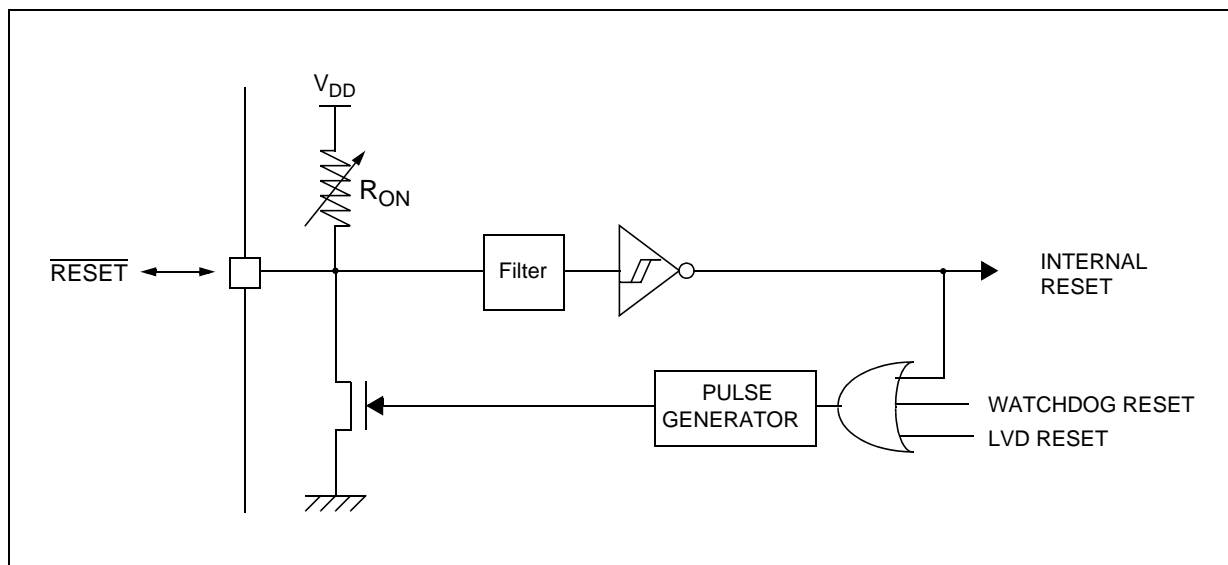

RESET SEQUENCE MANAGER (Cont'd)

The $\overline{\text{RESET}}$ pin is an asynchronous signal which plays a major role in EMS performance. In a noisy environment, it is recommended to follow the guidelines mentioned in the electrical characteristics section.

If the external $\overline{\text{RESET}}$ pulse is shorter than $t_{w(\text{RSTL})\text{out}}$ (see short ext. Reset in Figure 14), the signal on the RESET pin may be stretched. Otherwise the delay will not be applied (see long ext. Reset in Figure 14). Starting from the external RESET pulse recognition, the device $\overline{\text{RESET}}$ pin acts as an output that is pulled low during at least $t_{w(\text{RSTL})\text{out}}$.

6.3.3 External Power-On RESET

If the LVD is disabled by option byte, to start up the microcontroller correctly, the user must ensure by means of an external reset circuit that the reset signal is held low until V_{DD} is over the minimum level specified for the selected f_{OSC} frequency. (see "OPERATING CONDITIONS" on page 167)

A proper reset signal for a slow rising V_{DD} supply can generally be provided by an external RC network connected to the $\overline{\text{RESET}}$ pin.

6.3.4 Internal Low Voltage Detector (LVD) RESET

Two different RESET sequences caused by the internal LVD circuitry can be distinguished:

- Power-On RESET
- Voltage Drop RESET

The device $\overline{\text{RESET}}$ pin acts as an output that is pulled low when $V_{\text{DD}} < V_{\text{IT}+}$ (rising edge) or $V_{\text{DD}} < V_{\text{IT}-}$ (falling edge) as shown in Figure 14.

The LVD filters spikes on V_{DD} larger than $t_{\text{g}}(V_{\text{DD}})$ to avoid parasitic resets.

6.3.5 Internal Watchdog RESET

The RESET sequence generated by an internal Watchdog counter overflow is shown in Figure 14.

Starting from the Watchdog counter underflow, the device $\overline{\text{RESET}}$ pin acts as an output that is pulled low during at least $t_{w(\text{RSTL})\text{out}}$.

Figure 14. RESET Sequences

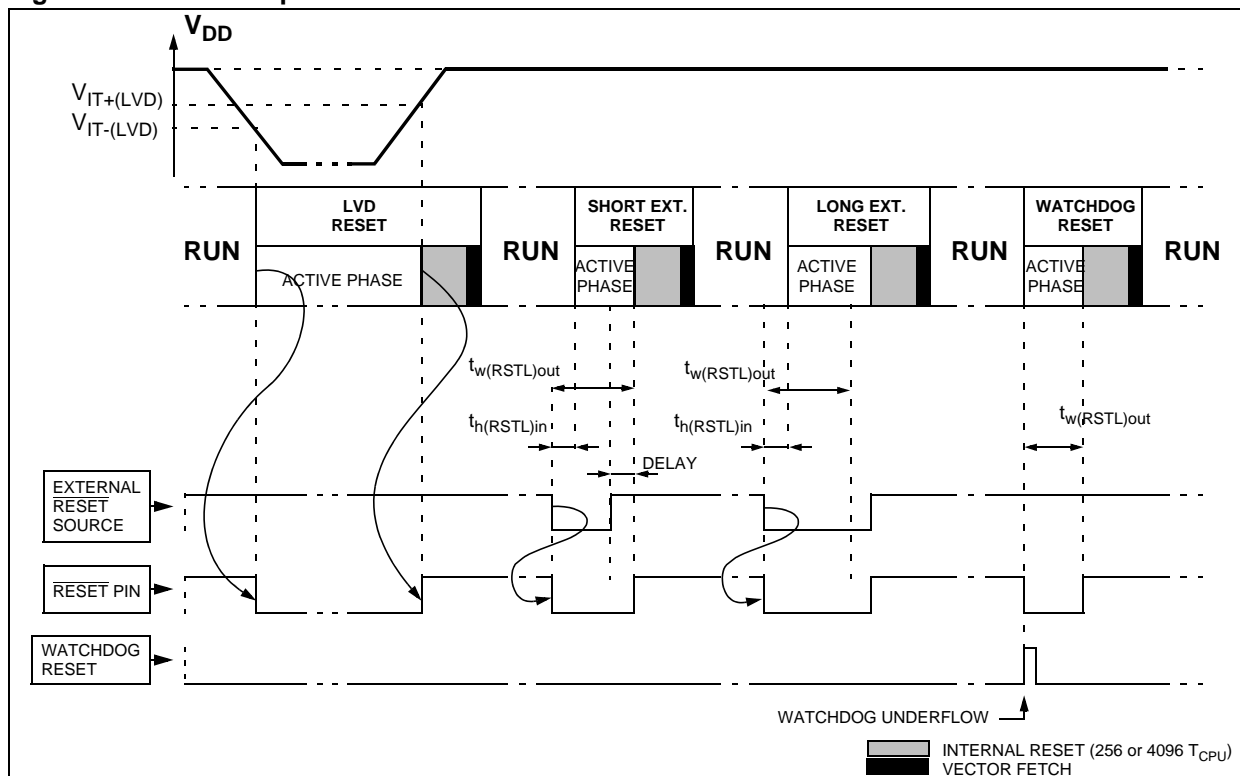

6.4 SYSTEM INTEGRITY MANAGEMENT (SI)

The System Integrity Management block contains the Low Voltage Detector (LVD) and Auxiliary Voltage Detector (AVD) functions. It is managed by the SICSR register.

6.4.1 Low Voltage Detector (LVD)

The Low Voltage Detector function (LVD) generates a static reset when the V_{DD} supply voltage is below a V_{IT-} reference value. This means that it secures the power-up as well as the power-down keeping the ST7 in reset.

The V_{IT-} reference value for a voltage drop is lower than the V_{IT+} reference value for power-on in order to avoid a parasitic reset when the MCU starts running and sinks current on the supply (hysteresis).

The LVD Reset circuitry generates a reset when V_{DD} is below:

- V_{IT+} when V_{DD} is rising
- V_{IT-} when V_{DD} is falling

The LVD function is illustrated in [Figure 15](#).

The voltage threshold can be configured by option byte to be low, medium or high.

Provided the minimum V_{DD} value (guaranteed for the oscillator frequency) is above V_{IT-} , the MCU can only be in two modes:

- under full software control
- in static safe reset

In these conditions, secure operation is always ensured for the application without the need for external reset hardware.

During a Low Voltage Detector Reset, the \overline{RESET} pin is held low, thus permitting the MCU to reset other devices.

Notes:

The LVD allows the device to be used without any external RESET circuitry.

If the medium or low thresholds are selected, the detection may occur outside the specified operating voltage range. Below 3.8V, device operation is not guaranteed.

The LVD is an optional function which can be selected by option byte.

It is recommended to make sure that the V_{DD} supply voltage rises monotonously when the device is exiting from Reset, to ensure the application functions properly.

Figure 15. Low Voltage Detector vs Reset

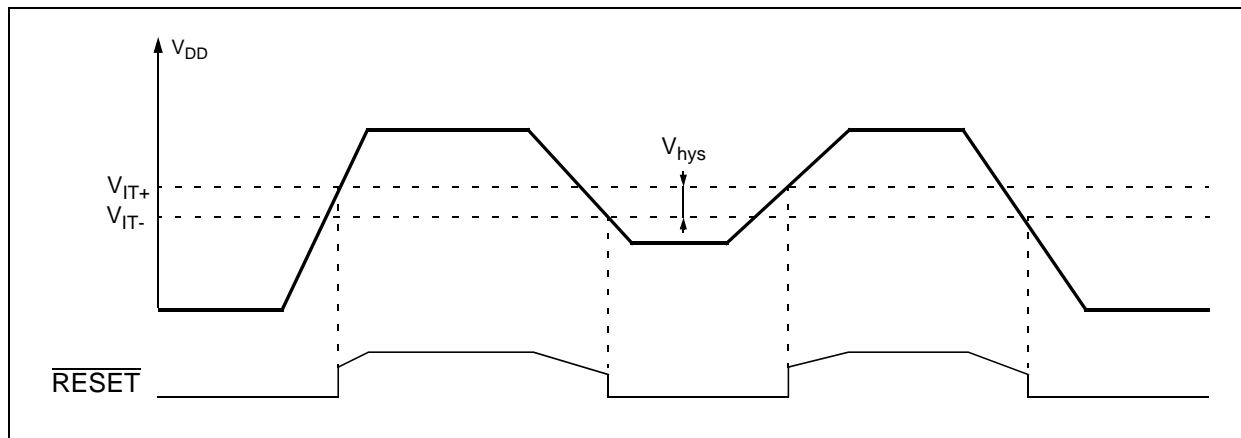

SYSTEM INTEGRITY MANAGEMENT (Cont'd)

6.4.2 Auxiliary Voltage Detector (AVD)

The Voltage Detector function (AVD) is based on an analog comparison between a $V_{IT-(AVD)}$ and $V_{IT+(AVD)}$ reference value and the V_{DD} main supply or the external EVD pin voltage level (V_{EVD}). The V_{IT-} reference value for falling voltage is lower than the V_{IT+} reference value for rising voltage in order to avoid parasitic detection (hysteresis).

The output of the AVD comparator is directly readable by the application software through a real time status bit (AVDF) in the SICSR register. This bit is read only.

Caution: The AVD function is active only if the LVD is enabled through the option byte.

6.4.2.1 Monitoring the V_{DD} Main Supply

This mode is selected by clearing the AVDS bit in the SICSR register.

The AVD voltage threshold value is relative to the selected LVD threshold configured by option byte (see section 14.1 on page 201).

If the AVD interrupt is enabled, an interrupt is generated when the voltage crosses the $V_{IT+(AVD)}$ or $V_{IT-(AVD)}$ threshold (AVDF bit toggles).

In the case of a drop in voltage, the AVD interrupt acts as an early warning, allowing software to shut down safely before the LVD resets the microcontroller. See Figure 16.

The interrupt on the rising edge is used to inform the application that the V_{DD} warning state is over.

If the voltage rise time t_{rv} is less than 256 or 4096 CPU cycles (depending on the reset delay selected by option byte), no AVD interrupt will be generated when $V_{IT+(AVD)}$ is reached.

If t_{rv} is greater than 256 or 4096 cycles then:

- If the AVD interrupt is enabled before the $V_{IT+(AVD)}$ threshold is reached, then 2 AVD interrupts will be received: the first when the AVDIE bit is set, and the second when the threshold is reached.
- If the AVD interrupt is enabled after the $V_{IT+(AVD)}$ threshold is reached then only one AVD interrupt will occur.

Figure 16. Using the AVD to Monitor V_{DD} (AVDS bit=0)

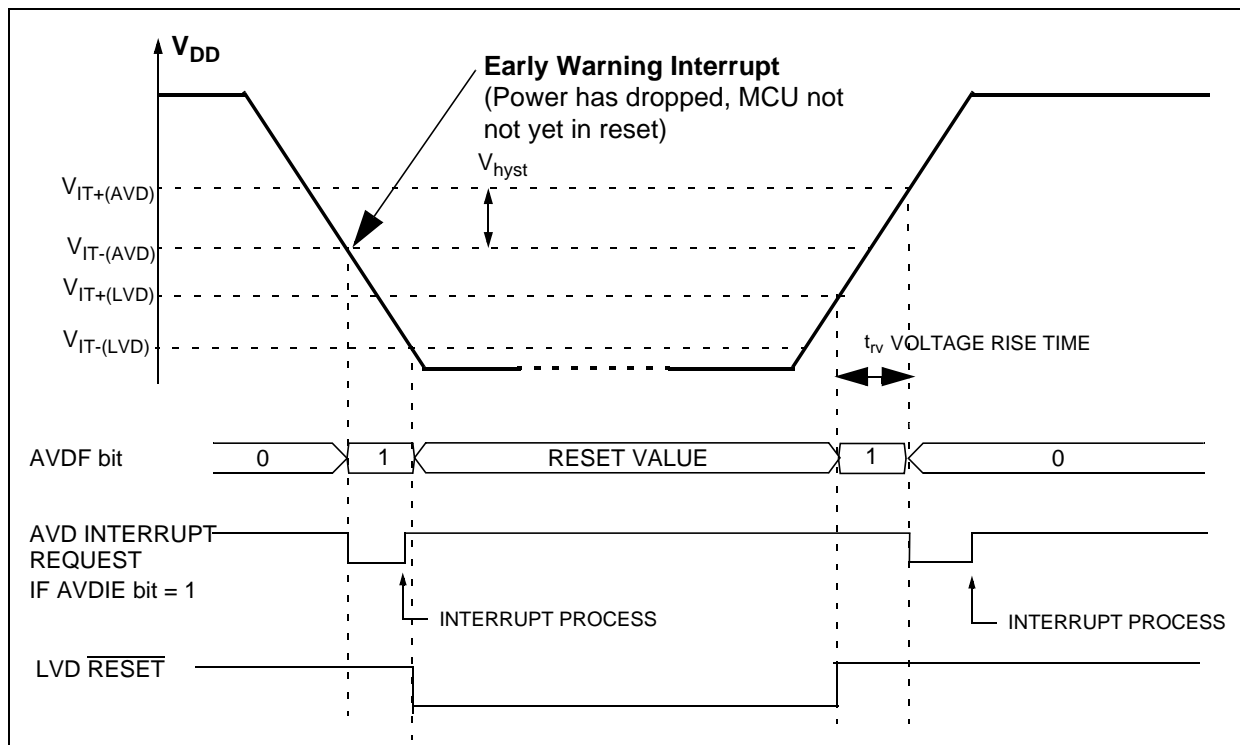

SYSTEM INTEGRITY MANAGEMENT (Cont'd)

6.4.2.2 Monitoring a Voltage on the EVD pin

This mode is selected by setting the AVDS bit in the SICSR register.

The AVD circuitry can generate an interrupt when the AVDIE bit of the SICSR register is set. This interrupt is generated on the rising and falling edges

of the comparator output. This means it is generated when either one of these two events occur:

- V_{EVD} rises up to $V_{IT+(EVD)}$
- V_{EVD} falls down to $V_{IT-(EVD)}$

The EVD function is illustrated in Figure 17.

For more details, refer to the Electrical Characteristics section.

Figure 17. Using the Voltage Detector to Monitor the EVD pin (AVDS bit=1)

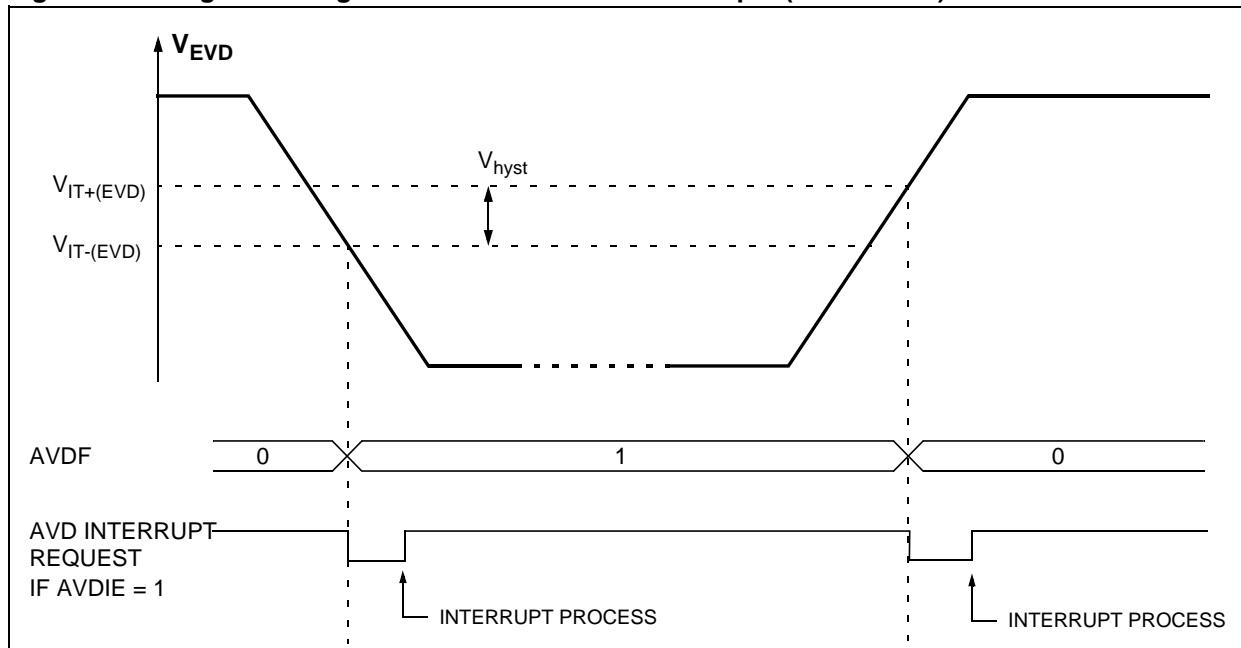

SYSTEM INTEGRITY MANAGEMENT (Cont'd)**6.4.3 Low Power Modes**

Mode	Description
WAIT	No effect on SI. AVD interrupts cause the device to exit from Wait mode.
HALT	The CRSR register is frozen.

6.4.3.1 Interrupts

The AVD interrupt event generates an interrupt if the corresponding Enable Control Bit (AVDIE) is

set and the interrupt mask in the CC register is reset (RIM instruction).

Interrupt Event	Event Flag	Enable Control Bit	Exit from Wait	Exit from Halt
AVD event	AVDF	AVDIE	Yes	No

SYSTEM INTEGRITY MANAGEMENT (Cont'd)

6.4.4 Register Description

SYSTEM INTEGRITY (SI) CONTROL/STATUS REGISTER (SICSR)

Read/Write

Reset Value: 000x 000x (00h)

7							0
AVD S	AVD IE	AVD F	LVD RF	0	0	0	WDG RF

Bit 7 = AVDS Voltage Detection selection

This bit is set and cleared by software. Voltage Detection is available only if the LVD is enabled by option byte.

- 0: Voltage detection on V_{DD} supply
- 1: Voltage detection on EVD pin

Bit 6 = AVDIE Voltage Detector interrupt enable

This bit is set and cleared by software. It enables an interrupt to be generated when the AVDF flag changes (toggles). The pending interrupt information is automatically cleared when software enters the AVD interrupt routine.

- 0: AVD interrupt disabled
- 1: AVD interrupt enabled

Bit 5 = AVDF Voltage Detector flag

This read-only bit is set and cleared by hardware. If the AVDIE bit is set, an interrupt request is generated when the AVDF bit changes value. Refer to [Figure 16](#) and to [Section 6.4.2.1](#) for additional details.

- 0: V_{DD} or V_{EVD} over V_{IT+(AVD)} threshold
- 1: V_{DD} or V_{EVD} under V_{IT-(AVD)} threshold

Bit 4 = LVDRF LVD reset flag

This bit indicates that the last Reset was generat-

ed by the LVD block. It is set by hardware (LVD reset) and cleared by software (writing zero). See WDGRF flag description for more details. When the LVD is disabled by OPTION BYTE, the LVDRF bit value is undefined.

Bits 3:1 = Reserved, must be kept cleared.

Bit 0 = WDGRF Watchdog reset flag

This bit indicates that the last Reset was generated by the Watchdog peripheral. It is set by hardware (watchdog reset) and cleared by software (writing zero) or an LVD Reset (to ensure a stable cleared state of the WDGRF flag when CPU starts).

Combined with the LVDRF flag information, the flag description is given by the following table.

RESET Sources	LVDRF	WDGRF
External RESET pin	0	0
Watchdog	0	1
LVD	1	X

Application notes

The LVDRF flag is not cleared when another RESET type occurs (external or watchdog), the LVDRF flag remains set to keep trace of the original failure.

In this case, a watchdog reset can be detected by software while an external reset can not.

CAUTION: When the LVD is not activated with the associated option byte, the WDGRF flag can not be used in the application.

7 INTERRUPTS

7.1 INTRODUCTION

The ST7 enhanced interrupt management provides the following features:

- Hardware interrupts
- Software interrupt (TRAP)
- Nested or concurrent interrupt management with flexible interrupt priority and level management:
 - Up to 4 software programmable nesting levels
 - Up to 16 interrupt vectors fixed by hardware
 - 2 non maskable events: RESET, TRAP
 - 1 maskable Top Level event: TLI

This interrupt management is based on:

- Bit 5 and bit 3 of the CPU CC register (I1:I0),
- Interrupt software priority registers (ISPRx),
- Fixed interrupt vector addresses located at the high addresses of the memory map (FFE0h to FFFFh) sorted by hardware priority order.

This enhanced interrupt controller guarantees full upward compatibility with the standard (not nested) ST7 interrupt controller.

7.2 MASKING AND PROCESSING FLOW

The interrupt masking is managed by the I1 and I0 bits of the CC register and the ISPRx registers which give the interrupt software priority level of

each interrupt vector (see Table 5). The processing flow is shown in Figure 18

When an interrupt request has to be serviced:

- Normal processing is suspended at the end of the current instruction execution.
- The PC, X, A and CC registers are saved onto the stack.
- I1 and I0 bits of CC register are set according to the corresponding values in the ISPRx registers of the serviced interrupt vector.
- The PC is then loaded with the interrupt vector of the interrupt to service and the first instruction of the interrupt service routine is fetched (refer to "Interrupt Mapping" table for vector addresses).

The interrupt service routine should end with the IRET instruction which causes the contents of the saved registers to be recovered from the stack.

Note: As a consequence of the IRET instruction, the I1 and I0 bits will be restored from the stack and the program in the previous level will resume.

Table 5. Interrupt Software Priority Levels

Interrupt software priority	Level	I1	I0
Level 0 (main)	↓ ↓ ↓ ↓ High	1	0
Level 1		0	1
Level 2		0	0
Level 3 (= interrupt disable)		1	1

Figure 18. Interrupt Processing Flowchart

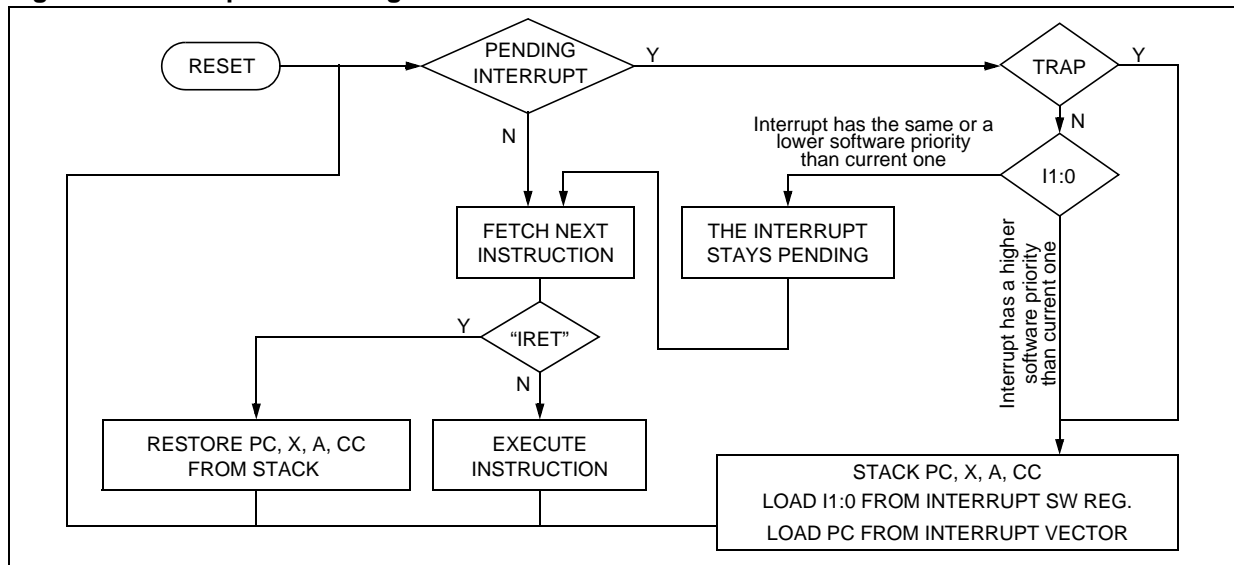

INTERRUPTS (Cont'd)

Servicing Pending Interrupts

As several interrupts can be pending at the same time, the interrupt to be taken into account is determined by the following two-step process:

- the highest software priority interrupt is serviced,
- if several interrupts have the same software priority then the interrupt with the highest hardware priority is serviced first.

Figure 19 describes this decision process.

Figure 19. Priority Decision Process

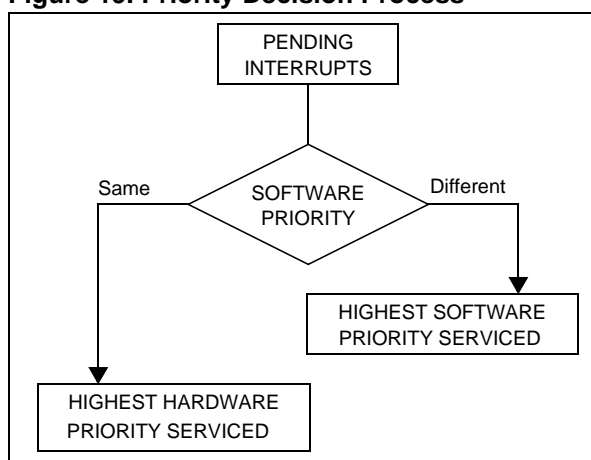

When an interrupt request is not serviced immediately, it is latched and then processed when its software priority combined with the hardware priority becomes the highest one.

Note 1: The hardware priority is exclusive while the software one is not. This allows the previous process to succeed with only one interrupt.

Note 2: TLI, RESET and TRAP can be considered as having the highest software priority in the decision process.

Different Interrupt Vector Sources

Two interrupt source types are managed by the ST7 interrupt controller: the non-maskable type (RESET, TRAP) and the maskable type (external or from internal peripherals).

Non-Maskable Sources

These sources are processed regardless of the state of the I1 and I0 bits of the CC register (see Figure 18). After stacking the PC, X, A and CC registers (except for RESET), the corresponding vector is loaded in the PC register and the I1 and I0 bits of the CC are set to disable interrupts (level 3). These sources allow the processor to exit HALT mode.

■ TRAP (Non Maskable Software Interrupt)

This software interrupt is serviced when the TRAP instruction is executed. It will be serviced according to the flowchart in Figure 18.

Caution: TRAP can be interrupted by a TLI.

■ RESET

The RESET source has the highest priority in the ST7. This means that the first current routine has the highest software priority (level 3) and the highest hardware priority.

See the RESET chapter for more details.

Maskable Sources

Maskable interrupt vector sources can be serviced if the corresponding interrupt is enabled and if its own interrupt software priority (in ISPRx registers) is higher than the one currently being serviced (I1 and I0 in CC register). If any of these two conditions is false, the interrupt is latched and thus remains pending.

■ TLI (Top Level Hardware Interrupt)

This hardware interrupt occurs when a specific edge is detected on the dedicated TLI pin. It will be serviced according to the flowchart in Figure 18 as a trap.

Caution: A TRAP instruction must not be used in a TLI service routine.

■ External Interrupts

External interrupts allow the processor to exit from HALT low power mode. External interrupt sensitivity is software selectable through the External Interrupt Control register (EICR).

External interrupt triggered on edge will be latched and the interrupt request automatically cleared upon entering the interrupt service routine.

If several input pins of a group connected to the same interrupt line are selected simultaneously, these will be logically ORed.

■ Peripheral Interrupts

Usually the peripheral interrupts cause the MCU to exit from HALT mode except those mentioned in the "Interrupt Mapping" table. A peripheral interrupt occurs when a specific flag is set in the peripheral status registers and if the corresponding enable bit is set in the peripheral control register.

The general sequence for clearing an interrupt is based on an access to the status register followed by a read or write to an associated register.

Note: The clearing sequence resets the internal latch. A pending interrupt (i.e. waiting for being serviced) will therefore be lost if the clear sequence is executed.

INTERRUPTS (Cont'd)

7.3 INTERRUPTS AND LOW POWER MODES

All interrupts allow the processor to exit the WAIT low power mode. On the contrary, only external and other specified interrupts allow the processor to exit from the HALT modes (see column "Exit from HALT" in "Interrupt Mapping" table). When several pending interrupts are present while exiting HALT mode, the first one serviced can only be an interrupt with exit from HALT mode capability and it is selected through the same decision process shown in Figure 19.

Note: If an interrupt, that is not able to Exit from HALT mode, is pending with the highest priority when exiting HALT mode, this interrupt is serviced after the first one serviced.

7.4 CONCURRENT & NESTED MANAGEMENT

The following Figure 20 and Figure 21 show two different interrupt management modes. The first is called concurrent mode and does not allow an interrupt to be interrupted, unlike the nested mode in Figure 21. The interrupt hardware priority is given in this order from the lowest to the highest: MAIN, IT4, IT3, IT2, IT1, IT0, TLI. The software priority is given for each interrupt.

Warning: A stack overflow may occur without notifying the software of the failure.

Figure 20. Concurrent Interrupt Management

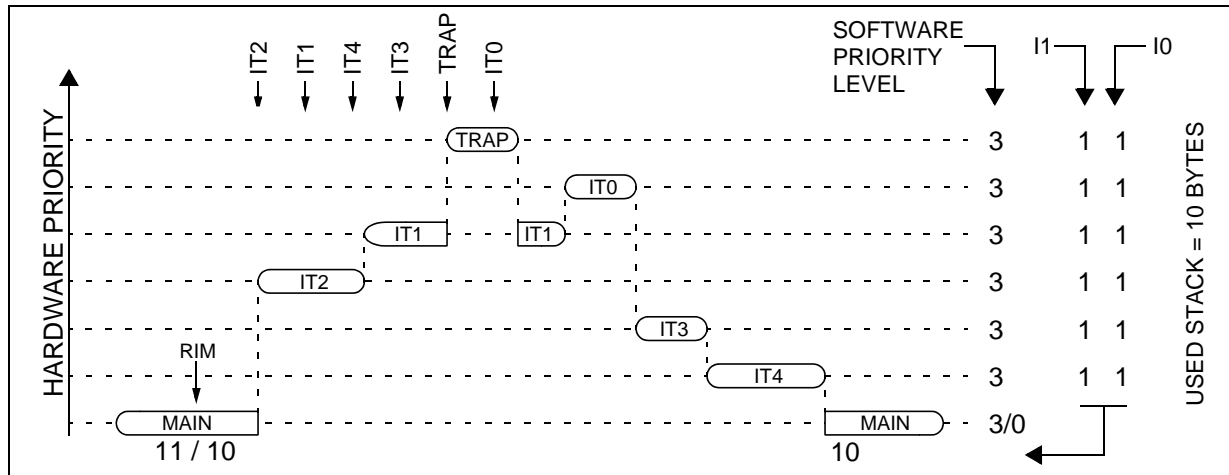
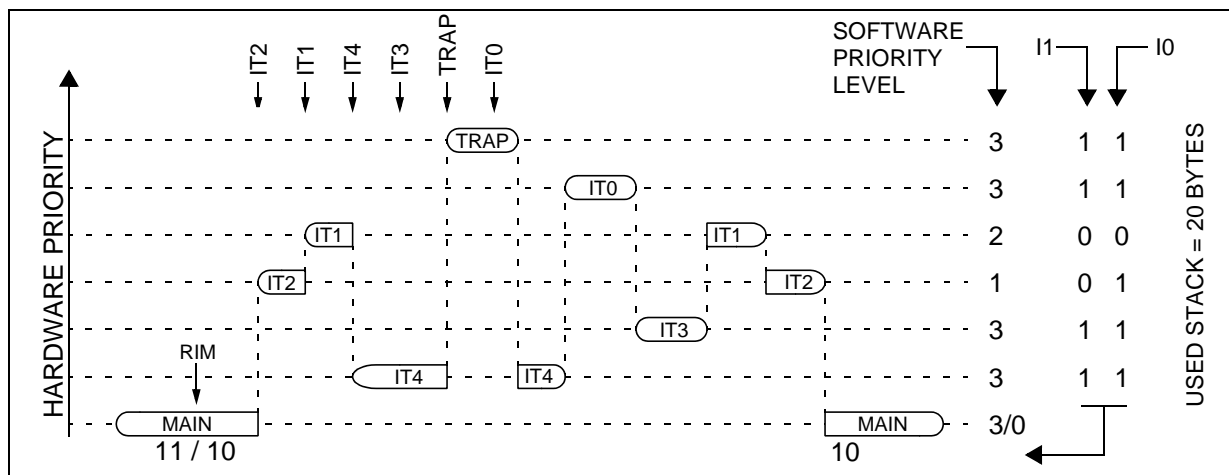

Figure 21. Nested Interrupt Management



INTERRUPTS (Cont'd)

7.5 INTERRUPT REGISTER DESCRIPTION

CPU CC REGISTER INTERRUPT BITS

Read/Write

Reset Value: 111x 1010 (xAh)

7								0
1	1	I1	H	I0	N	Z	C	

Bit 5, 3 = I1, I0 Software Interrupt Priority

These two bits indicate the current interrupt software priority.

Interrupt Software Priority	Level	I1	I0
Level 0 (main)	Low	1	0
Level 1	↓	0	1
Level 2		0	0
Level 3 (= interrupt disable*)		High	1

These two bits are set/cleared by hardware when entering in interrupt. The loaded value is given by the corresponding bits in the interrupt software priority registers (ISPRx).

They can be also set/cleared by software with the RIM, SIM, HALT, WFI, IRET and PUSH/POP instructions (see "Interrupt Dedicated Instruction Set" table).

***Note:** TLI, TRAP and RESET events can interrupt a level 3 program.

INTERRUPT SOFTWARE PRIORITY REGISTERS (ISPRX)

Read/Write (bit 7:4 of ISPR3 are read only)

Reset Value: 1111 1111 (FFh)

	7							0
ISPR0	I1_3	I0_3	I1_2	I0_2	I1_1	I0_1	I1_0	I0_0
ISPR1	I1_7	I0_7	I1_6	I0_6	I1_5	I0_5	I1_4	I0_4
ISPR2	I1_11	I0_11	I1_10	I0_10	I1_9	I0_9	I1_8	I0_8
ISPR3	1	1	1	1	I1_13	I0_13	I1_12	I0_12

These four registers contain the interrupt software priority of each interrupt vector.

– Each interrupt vector (except RESET and TRAP) has corresponding bits in these registers where its own software priority is stored. This correspondence is shown in the following table.

Vector address	ISPRx bits
FFFBh-FFFAh	I1_0 and I0_0 bits*
FFF9h-FFF8h	I1_1 and I0_1 bits
...	...
FFE1h-FFE0h	I1_13 and I0_13 bits

– Each I1_x and I0_x bit value in the ISPRx registers has the same meaning as the I1 and I0 bits in the CC register.

– Level 0 can not be written (I1_x=1, I0_x=0). In this case, the previously stored value is kept. (example: previous=CFh, write=64h, result=44h)

The TLI, RESET, and TRAP vectors have no software priorities. When one is serviced, the I1 and I0 bits of the CC register are both set.

***Note:** Bits in the ISPRx registers which correspond to the TLI can be read and written but they are not significant in the interrupt process management.

Caution: If the I1_x and I0_x bits are modified while the interrupt x is executed the following behaviour has to be considered: If the interrupt x is still pending (new interrupt or flag not cleared) and the new software priority is higher than the previous one, the interrupt x is re-entered. Otherwise, the software priority stays unchanged up to the next interrupt request (after the IRET of the interrupt x).

INTERRUPTS (Cont'd)

Table 6. Dedicated Interrupt Instruction Set

Instruction	New Description	Function/Example	I1	H	I0	N	Z	C
HALT	Entering Halt mode		1		0			
IRET	Interrupt routine return	Pop CC, A, X, PC	I1	H	I0	N	Z	C
JRM	Jump if I1:0=11 (level 3)	I1:0=11 ?						
JRNM	Jump if I1:0<>11	I1:0<>11 ?						
POP CC	Pop CC from the Stack	Mem => CC	I1	H	I0	N	Z	C
RIM	Enable interrupt (level 0 set)	Load I0 in I1:0 of CC	1		0			
SIM	Disable interrupt (level 3 set)	Load I1 in I1:0 of CC	1		1			
TRAP	Software trap	Software NMI	1		1			
WFI	Wait for interrupt		1		0			

Note: During the execution of an interrupt routine, the HALT, POPCC, RIM, SIM and WFI instructions change the current software priority up to the next IRET instruction or one of the previously mentioned instructions.

INTERRUPTS (Cont'd)

Table 7. Interrupt Mapping

N°	Source Block	Description	Register Label	Priority Order	Exit from HALT/ACTIVE HALT ³⁾	Address Vector
	RESET	Reset	N/A		yes	FFFEh-FFFFh
	TRAP	Software interrupt			no	FFFCh-FFFDh
0	TLI	External top level interrupt	EICR		yes	FFFAh-FFFBh
1	MCC/RTC	Main clock controller time base interrupt	MCCSR	Higher Priority ↓ Lower Priority	yes	FFF8h-FFF9h
2	ei0	External interrupt port A3..0	N/A		yes	FFF6h-FFF7h
3	ei1	External interrupt port F2..0			yes	FFF4h-FFF5h
4	ei2	External interrupt port B3..0			yes	FFF2h-FFF3h
5	ei3	External interrupt port B7..4			yes	FFF0h-FFF1h
6	CAN	CAN peripheral interrupts	CANISR		yes	FFEEh-FFEFh
7	SPI	SPI peripheral interrupts	SPICSR		yes ¹	FFECh-FFEDh
8	TIMER A	TIMER A peripheral interrupts	TASR		no	FFEAh-FFEBh
9	TIMER B	TIMER B peripheral interrupts	TBSR		no	FFE8h-FFE9h
10	SCI	SCI Peripheral interrupts	SCISR		no	FFE6h-FFE7h
11	AVD	Auxiliary Voltage detector interrupt	SICSR		no	FFE4h-FFE5h
12	I2C	I2C Peripheral interrupts	(see periph)		no	FFE2h-FFE3h
13	PWM ART	PWM ART interrupt	ARTCSR			yes ²

Notes:

1. Exit from HALT possible when SPI is in slave mode.
2. Exit from HALT possible when PWM ART is in external clock mode.
3. In Flash devices only a RESET or MCC/RTC interrupt can be used to wake-up from Active Halt mode.

7.6 EXTERNAL INTERRUPTS

7.6.1 I/O Port Interrupt Sensitivity

The external interrupt sensitivity is controlled by the IPA, IPB and ISxx bits of the EICR register (Figure 22). This control allows to have up to 4 fully independent external interrupt source sensitivities.

Each external interrupt source can be generated on four (or five) different events on the pin:

- Falling edge
- Rising edge
- Falling and rising edge

- Falling edge and low level
- Rising edge and high level (only for ei0 and ei2)

To guarantee correct functionality, the sensitivity bits in the EICR register can be modified only when the I1 and I0 bits of the CC register are both set to 1 (level 3). This means that interrupts must be disabled before changing sensitivity.

The pending interrupts are cleared by writing a different value in the ISx[1:0], IPA or IPB bits of the EICR.

INTERRUPTS (Cont'd)

Figure 22. External Interrupt Control bits

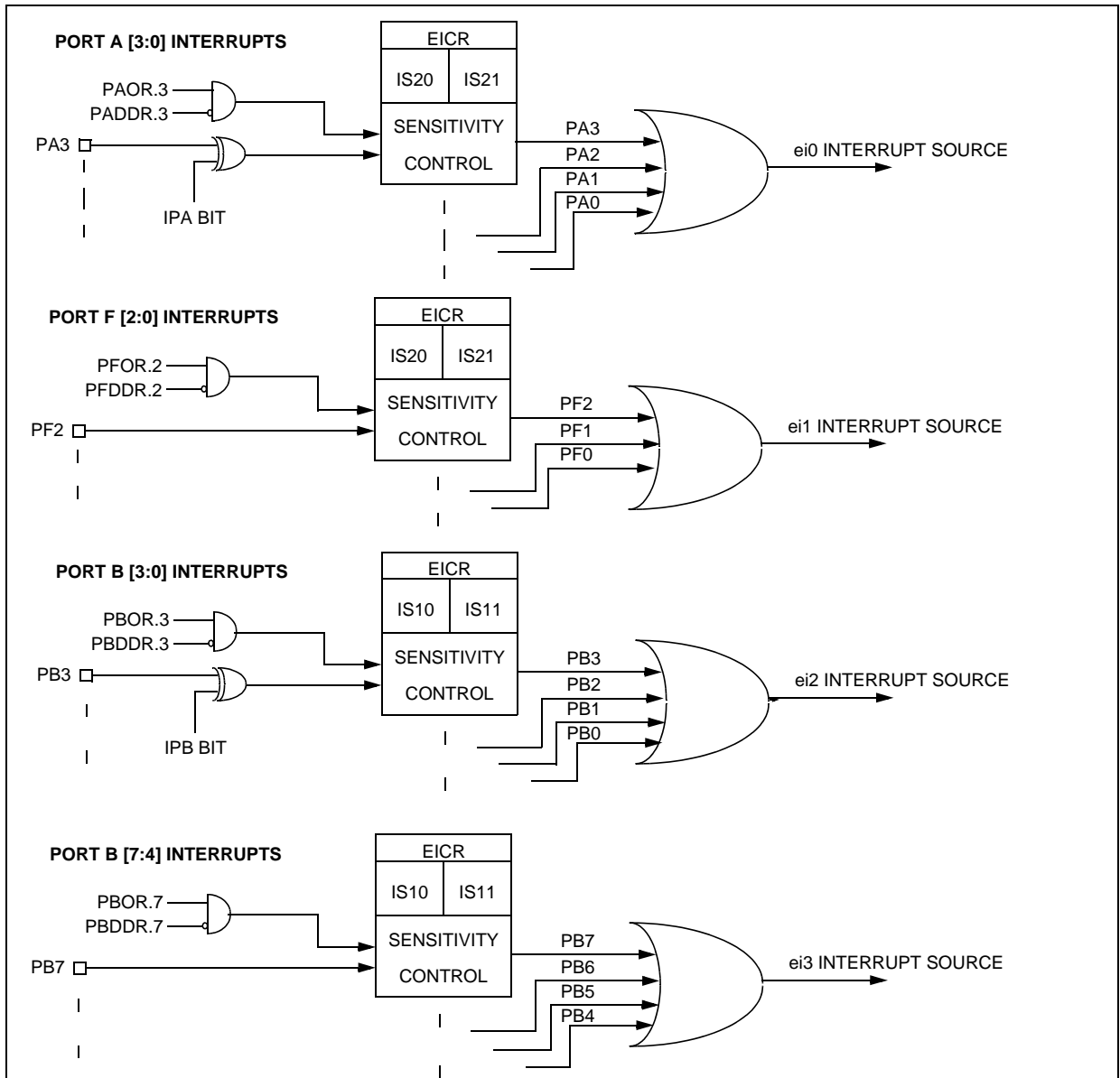

7.7 EXTERNAL INTERRUPT CONTROL REGISTER (EICR)

Read/Write

Reset Value: 0000 0000 (00h)

7							0
IS11	IS10	IPB	IS21	IS20	IPA	TLIS	TLIE

Bit 7:6 = **IS1[1:0]** *ei2 and ei3 sensitivity*
 The interrupt sensitivity, defined using the IS1[1:0] bits, is applied to the following external interrupts:
 - ei2 (port B3..0)

IS11	IS10	External Interrupt Sensitivity	
		IPB bit =0	IPB bit =1
0	0	Falling edge & low level	Rising edge & high level
0	1	Rising edge only	Falling edge only
1	0	Falling edge only	Rising edge only
1	1	Rising and falling edge	

- ei3 (port B7..4)

IS11	IS10	External Interrupt Sensitivity
0	0	Falling edge & low level
0	1	Rising edge only
1	0	Falling edge only
1	1	Rising and falling edge

These 2 bits can be written only when I1 and I0 of the CC register are both set to 1 (level 3).

Bit 5 = **IPB** *Interrupt polarity for port B*
 This bit is used to invert the sensitivity of the port B [3:0] external interrupts. It can be set and cleared by software only when I1 and I0 of the CC register are both set to 1 (level 3).
 0: No sensitivity inversion
 1: Sensitivity inversion

Bit 4:3 = **IS2[1:0]** *ei0 and ei1 sensitivity*
 The interrupt sensitivity, defined using the IS2[1:0] bits, is applied to the following external interrupts:

- ei0 (port A3..0)

IS21	IS20	External Interrupt Sensitivity	
		IPA bit =0	IPA bit =1
0	0	Falling edge & low level	Rising edge & high level
0	1	Rising edge only	Falling edge only
1	0	Falling edge only	Rising edge only
1	1	Rising and falling edge	

- ei1 (port F2..0)

IS21	IS20	External Interrupt Sensitivity
0	0	Falling edge & low level
0	1	Rising edge only
1	0	Falling edge only
1	1	Rising and falling edge

These 2 bits can be written only when I1 and I0 of the CC register are both set to 1 (level 3).

Bit 2 = **IPA** *Interrupt polarity for port A*
 This bit is used to invert the sensitivity of the port A [3:0] external interrupts. It can be set and cleared by software only when I1 and I0 of the CC register are both set to 1 (level 3).
 0: No sensitivity inversion
 1: Sensitivity inversion

Bit 1 = **TLIS** *TLI sensitivity*
 This bit allows to toggle the TLI edge sensitivity. It can be set and cleared by software only when TLIE bit is cleared.
 0: Falling edge
 1: Rising edge

Bit 0 = **TLIE** *TLI enable*
 This bit allows to enable or disable the TLI capability on the dedicated pin. It is set and cleared by software.
 0: TLI disabled
 1: TLI enabled
Note: a parasitic interrupt can be generated when clearing the TLIE bit.

INTERRUPTS (Cont'd)

Table 8. Nested Interrupts Register Map and Reset Values

Address (Hex.)	Register Label	7	6	5	4	3	2	1	0
0024h	ISPR0 Reset Value	ei1		ei0		MCC		TLI	
		I1_3 1	I0_3 1	I1_2 1	I0_2 1	I1_1 1	I0_1 1	1	1
0025h	ISPR1 Reset Value	SPI		CAN		ei3		ei2	
		I1_7 1	I0_7 1	I1_6 1	I0_6 1	I1_5 1	I0_5 1	I1_4 1	I0_4 1
0026h	ISPR2 Reset Value	AVD		SCI		TIMER B		TIMER A	
		I1_11 1	I0_11 1	I1_10 1	I0_10 1	I1_9 1	I0_9 1	I1_8 1	I0_8 1
0027h	ISPR3 Reset Value					PWMART		I2C	
		1	1	1	1	I1_13 1	I0_13 1	I1_12 1	I0_12 1
0028h	EICR Reset Value	IS11 0	IS10 0	IPB 0	IS21 0	IS20 0	IPA 0	TLIS 0	TLIE 0

8 POWER SAVING MODES

8.1 INTRODUCTION

To give a large measure of flexibility to the application in terms of power consumption, four main power saving modes are implemented in the ST7 (see Figure 23): SLOW, WAIT (SLOW WAIT), ACTIVE HALT and HALT.

After a RESET the normal operating mode is selected by default (RUN mode). This mode drives the device (CPU and embedded peripherals) by means of a master clock which is based on the main oscillator frequency divided or multiplied by 2 (f_{OSC2}).

From RUN mode, the different power saving modes may be selected by setting the relevant register bits or by calling the specific ST7 software instruction whose action depends on the oscillator status.

Figure 23. Power Saving Mode Transitions

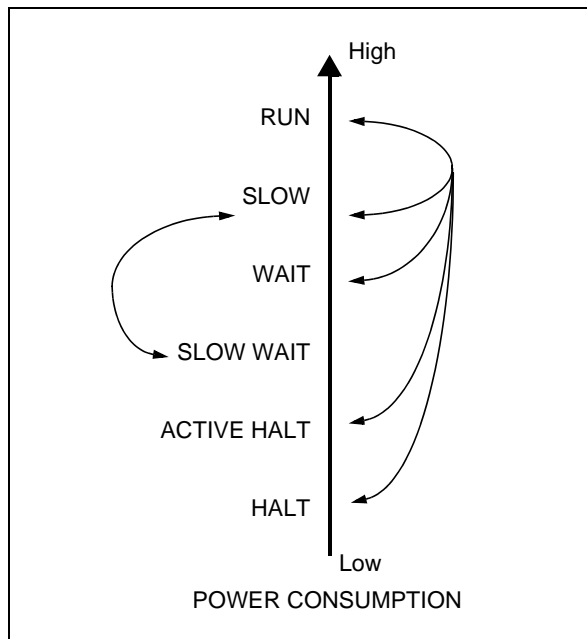

8.2 SLOW MODE

This mode has two targets:

- To reduce power consumption by decreasing the internal clock in the device,
- To adapt the internal clock frequency (f_{CPU}) to the available supply voltage.

SLOW mode is controlled by three bits in the MCCSR register: the SMS bit which enables or disables Slow mode and two CPx bits which select the internal slow frequency (f_{CPU}).

In this mode, the master clock frequency (f_{OSC2}) can be divided by 2, 4, 8 or 16. The CPU and peripherals are clocked at this lower frequency (f_{CPU}).

Note: SLOW-WAIT mode is activated when entering the WAIT mode while the device is already in SLOW mode.

Figure 24. SLOW Mode Clock Transitions

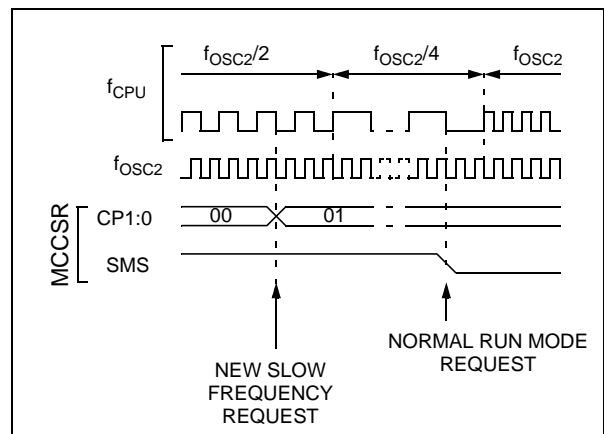

POWER SAVING MODES (Cont'd)

8.3 WAIT MODE

WAIT mode places the MCU in a low power consumption mode by stopping the CPU.

This power saving mode is selected by calling the 'WFI' instruction.

All peripherals remain active. During WAIT mode, the I[1:0] bits of the CC register are forced to '10', to enable all interrupts. All other registers and memory remain unchanged. The MCU remains in WAIT mode until an interrupt or RESET occurs, whereupon the Program Counter branches to the starting address of the interrupt or Reset service routine.

The MCU will remain in WAIT mode until a Reset or an Interrupt occurs, causing it to wake up.

Refer to [Figure 25](#).

Figure 25. WAIT Mode Flow-chart

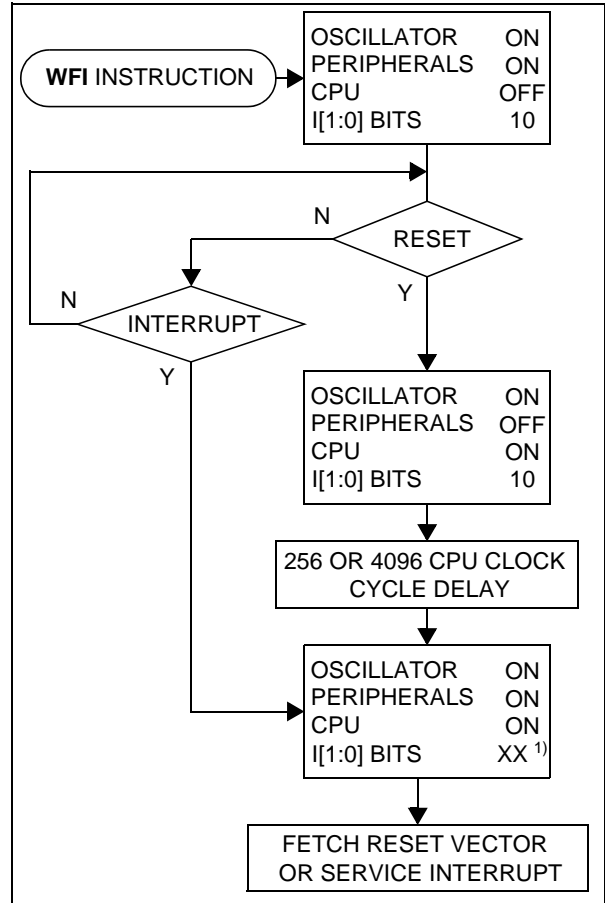
**Note:**

1. Before servicing an interrupt, the CC register is pushed on the stack. The I[1:0] bits of the CC register are set to the current software priority level of the interrupt routine and recovered when the CC register is popped.

POWER SAVING MODES (Cont'd)

8.4 ACTIVE-HALT AND HALT MODES

ACTIVE-HALT and HALT modes are the two lowest power consumption modes of the MCU. They are both entered by executing the 'HALT' instruction. The decision to enter either in ACTIVE-HALT or HALT mode is given by the MCC/RTC interrupt enable flag (OIE bit in MCCSR register).

MCCSR OIE bit	Power Saving Mode entered when HALT instruction is executed
0	HALT mode
1	ACTIVE-HALT mode

8.4.1 ACTIVE-HALT MODE

ACTIVE-HALT mode is the lowest power consumption mode of the MCU with a real time clock available. It is entered by executing the 'HALT' instruction when the OIE bit of the Main Clock Controller Status register (MCCSR) is set (see section 10.2 on page 58 for more details on the MCCSR register).

The MCU can exit ACTIVE-HALT mode on reception of an MCC/RTC interrupt or a RESET. In ROM devices, external interrupts can be used to wake-up the MCU. When exiting ACTIVE-HALT mode by means of an interrupt, no 256 or 4096 CPU cycle delay occurs. The CPU resumes operation by servicing the interrupt or by fetching the reset vector which woke it up (see Figure 27).

When entering ACTIVE-HALT mode, the I[1:0] bits in the CC register are forced to '10b' to enable interrupts. Therefore, if an interrupt is pending, the MCU wakes up immediately.

In ACTIVE-HALT mode, only the main oscillator and its associated counter (MCC/RTC) are running to keep a wake-up time base. All other peripherals are not clocked except those which get their clock supply from another clock generator (such as external or auxiliary oscillator).

The safeguard against staying locked in ACTIVE-HALT mode is provided by the oscillator interrupt.

Note: As soon as the interrupt capability of one of the oscillators is selected (MCCSR.OIE bit set), entering ACTIVE-HALT mode while the Watchdog is active does not generate a RESET.

This means that the device cannot spend more than a defined delay in this power saving mode.

CAUTION: When exiting ACTIVE-HALT mode following an MCC/RTC interrupt, OIE bit of MCCSR register must not be cleared before t_{DELAY} after the interrupt occurs ($t_{DELAY} = 256$ or $4096 t_{CPU}$ de-

lay depending on option byte). Otherwise, the ST7 enters HALT mode for the remaining t_{DELAY} period.

Figure 26. ACTIVE-HALT Timing Overview

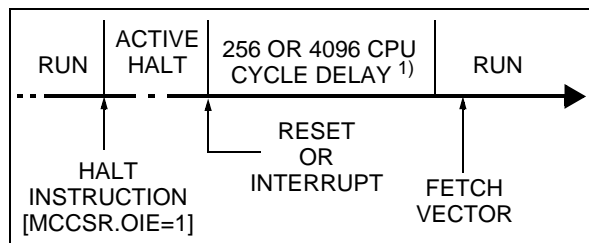
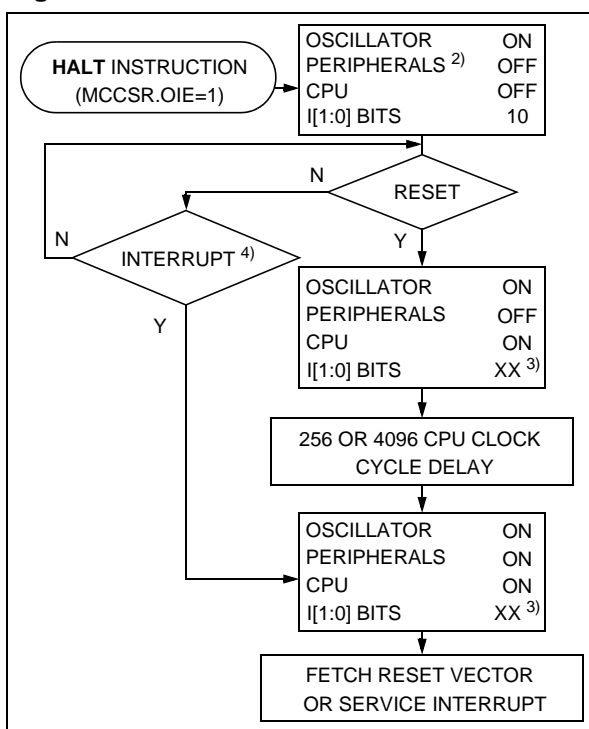

Figure 27. ACTIVE-HALT Mode Flow-chart



Notes:

1. This delay occurs only if the MCU exits ACTIVE-HALT mode by means of a RESET.
2. Peripheral clocked with an external clock source can still be active.
3. Before servicing an interrupt, the CC register is pushed on the stack. The I[1:0] bits of the CC register are set to the current software priority level of the interrupt routine and restored when the CC register is popped.
4. In flash devices only the MCC/RTC interrupt can exit the MCU from ACTIVE-HALT mode.

POWER SAVING MODES (Cont'd)

8.4.2 HALT MODE

The HALT mode is the lowest power consumption mode of the MCU. It is entered by executing the 'HALT' instruction when the OIE bit of the Main Clock Controller Status register (MCCSR) is cleared (see [section 10.2 on page 58](#) for more details on the MCCSR register).

The MCU can exit HALT mode on reception of either a specific interrupt (see Table 7, "Interrupt Mapping," on page 38) or a RESET. When exiting HALT mode by means of a RESET or an interrupt, the oscillator is immediately turned on and the 256 or 4096 CPU cycle delay is used to stabilize the oscillator. After the start up delay, the CPU resumes operation by servicing the interrupt or by fetching the reset vector which woke it up (see [Figure 29](#)).

When entering HALT mode, the I[1:0] bits in the CC register are forced to '10b' to enable interrupts. Therefore, if an interrupt is pending, the MCU wakes up immediately.

In HALT mode, the main oscillator is turned off causing all internal processing to be stopped, including the operation of the on-chip peripherals. All peripherals are not clocked except the ones which get their clock supply from another clock generator (such as an external or auxiliary oscillator).

The compatibility of Watchdog operation with HALT mode is configured by the "WDGHALT" option bit of the option byte. The HALT instruction when executed while the Watchdog system is enabled, can generate a Watchdog RESET (see [section 14.1 on page 201](#) for more details).

Figure 28. HALT Timing Overview

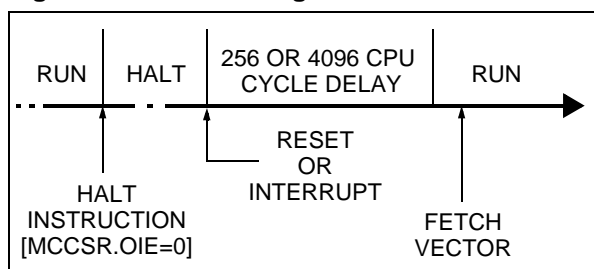
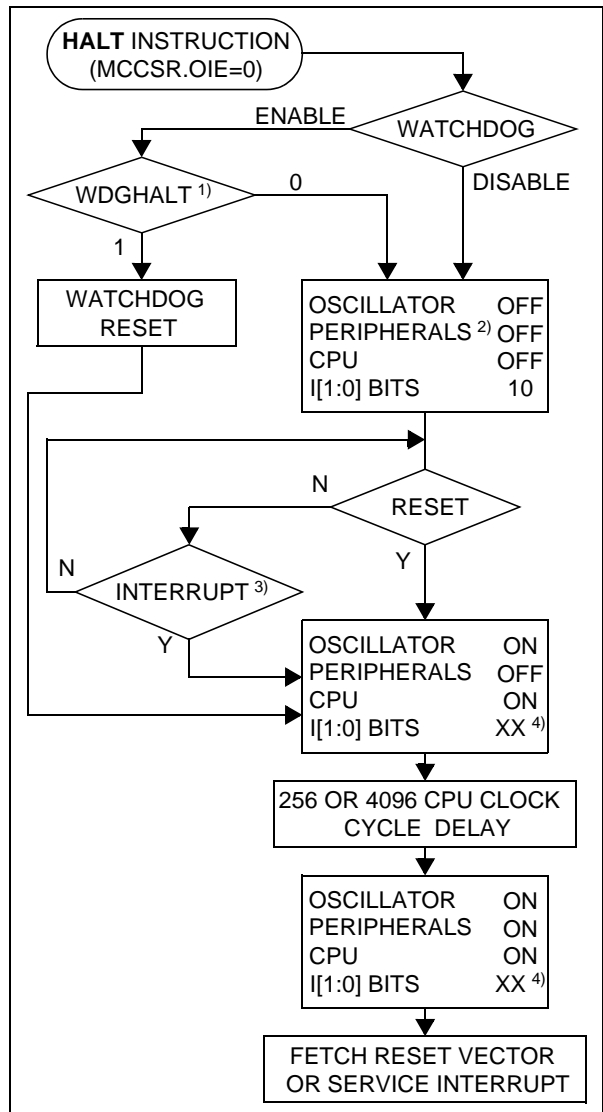

Figure 29. HALT Mode Flow-chart



Notes:

1. WDGHALT is an option bit. See option byte section for more details.
2. Peripheral clocked with an external clock source can still be active.
3. Only some specific interrupts can exit the MCU from HALT mode (such as external interrupt). Refer to Table 7, "Interrupt Mapping," on page 38 for more details.
4. Before servicing an interrupt, the CC register is pushed on the stack. The I[1:0] bits of the CC register are set to the current software priority level of the interrupt routine and recovered when the CC register is popped.

POWER SAVING MODES (Cont'd)

8.4.2.1 Halt Mode Recommendations

- Make sure that an external event is available to wake up the microcontroller from Halt mode.
- When using an external interrupt to wake up the microcontroller, reinitialize the corresponding I/O as “Input Pull-up with Interrupt” before executing the HALT instruction. The main reason for this is that the I/O may be wrongly configured due to external interference or by an unforeseen logical condition.
- For the same reason, reinitialize the level sensitivity of each external interrupt as a precautionary measure.
- The opcode for the HALT instruction is 0x8E. To avoid an unexpected HALT instruction due to a program counter failure, it is advised to clear all occurrences of the data value 0x8E from memo-

ry. For example, avoid defining a constant in ROM with the value 0x8E.

- As the HALT instruction clears the interrupt mask in the CC register to allow interrupts, the user may choose to clear all pending interrupt bits before executing the HALT instruction. This avoids entering other peripheral interrupt routines after executing the external interrupt routine corresponding to the wake-up event (reset or external interrupt).

Related Documentation

AN 980: ST7 Keypad Decoding Techniques, Implementing Wake-Up on Keystroke

AN1014: How to Minimize the ST7 Power Consumption

AN1605: Using an active RC to wakeup the ST7LITE0 from power saving mode

9 I/O PORTS

9.1 INTRODUCTION

The I/O ports offer different functional modes:

- transfer of data through digital inputs and outputs and for specific pins:
- external interrupt generation
- alternate signal input/output for the on-chip peripherals.

An I/O port contains up to 8 pins. Each pin can be programmed independently as digital input (with or without interrupt generation) or digital output.

9.2 FUNCTIONAL DESCRIPTION

Each port has 2 main registers:

- Data Register (DR)
- Data Direction Register (DDR)

and one optional register:

- Option Register (OR)

Each I/O pin may be programmed using the corresponding register bits in the DDR and OR registers: bit X corresponding to pin X of the port. The same correspondence is used for the DR register.

The following description takes into account the OR register, (for specific ports which do not provide this register refer to the I/O Port Implementation section). The generic I/O block diagram is shown in [Figure 30](#)

9.2.1 Input Modes

The input configuration is selected by clearing the corresponding DDR register bit.

In this case, reading the DR register returns the digital value applied to the external I/O pin.

Different input modes can be selected by software through the OR register.

Notes:

1. Writing the DR register modifies the latch value but does not affect the pin status.
2. When switching from input to output mode, the DR register has to be written first to drive the correct level on the pin as soon as the port is configured as an output.
3. Do not use read/modify/write instructions (BSET or BRES) to modify the DR register

External interrupt function

When an I/O is configured as Input with Interrupt, an event on this I/O can generate an external interrupt request to the CPU.

Each pin can independently generate an interrupt request. The interrupt sensitivity is independently programmable using the sensitivity bits in the EICR register.

Each external interrupt vector is linked to a dedicated group of I/O port pins (see pinout description and interrupt section). If several input pins are selected simultaneously as interrupt sources, these are first detected according to the sensitivity bits in the EICR register and then logically ORed.

The external interrupts are hardware interrupts, which means that the request latch (not accessible directly by the application) is automatically cleared when the corresponding interrupt vector is fetched. To clear an unwanted pending interrupt by software, the sensitivity bits in the EICR register must be modified.

9.2.2 Output Modes

The output configuration is selected by setting the corresponding DDR register bit. In this case, writing the DR register applies this digital value to the I/O pin through the latch. Then reading the DR register returns the previously stored value.

Two different output modes can be selected by software through the OR register: Output push-pull and open-drain.

DR register value and output pin status:

DR	Push-pull	Open-drain
0	V _{SS}	V _{SS}
1	V _{DD}	Floating

9.2.3 Alternate Functions

When an on-chip peripheral is configured to use a pin, the alternate function is automatically selected. This alternate function takes priority over the standard I/O programming.

When the signal is coming from an on-chip peripheral, the I/O pin is automatically configured in output mode (push-pull or open drain according to the peripheral).

When the signal is going to an on-chip peripheral, the I/O pin must be configured in input mode. In this case, the pin state is also digitally readable by addressing the DR register.

Note: Input pull-up configuration can cause unexpected value at the input of the alternate peripheral input. When an on-chip peripheral use a pin as input and output, this pin has to be configured in input floating mode.

I/O PORTS (Cont'd)

Figure 30. I/O Port General Block Diagram

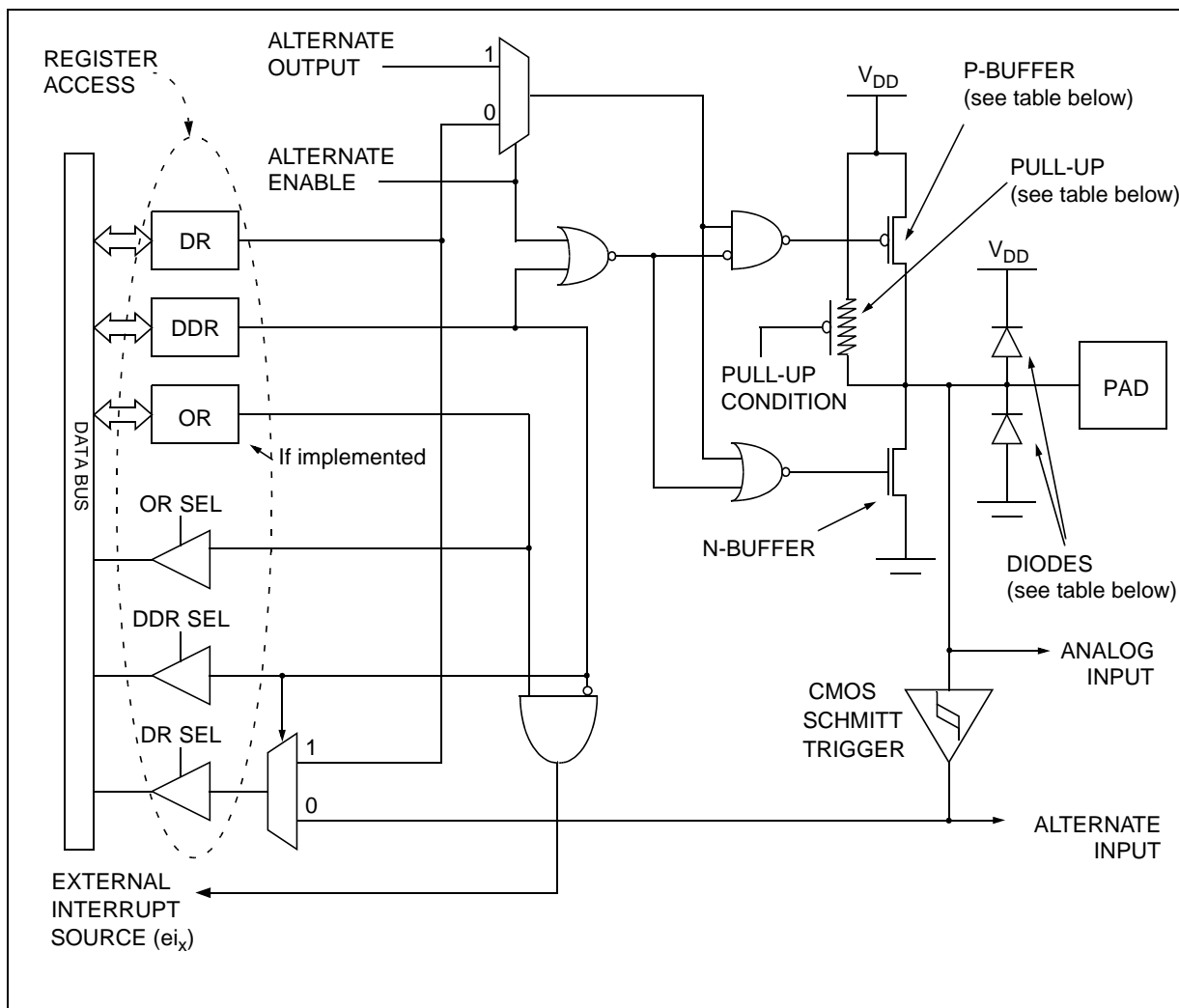

Table 9. I/O Port Mode Options

Configuration Mode		Pull-Up	P-Buffer	Diodes	
				to V _{DD}	to V _{SS}
Input	Floating with/without Interrupt	Off	Off	On	On
	Pull-up with/without Interrupt	On			
Output	Push-pull	Off	On	NI (see note)	On
	Open Drain (logic level)		Off		
	True Open Drain	NI	NI		

Legend: NI - not implemented
 Off - implemented not activated
 On - implemented and activated

Note: The diode to V_{DD} is not implemented in the true open drain pads. A local protection between the pad and V_{SS} is implemented to protect the device against positive stress.

I/O PORTS (Cont'd)

Table 10. I/O Port Configurations

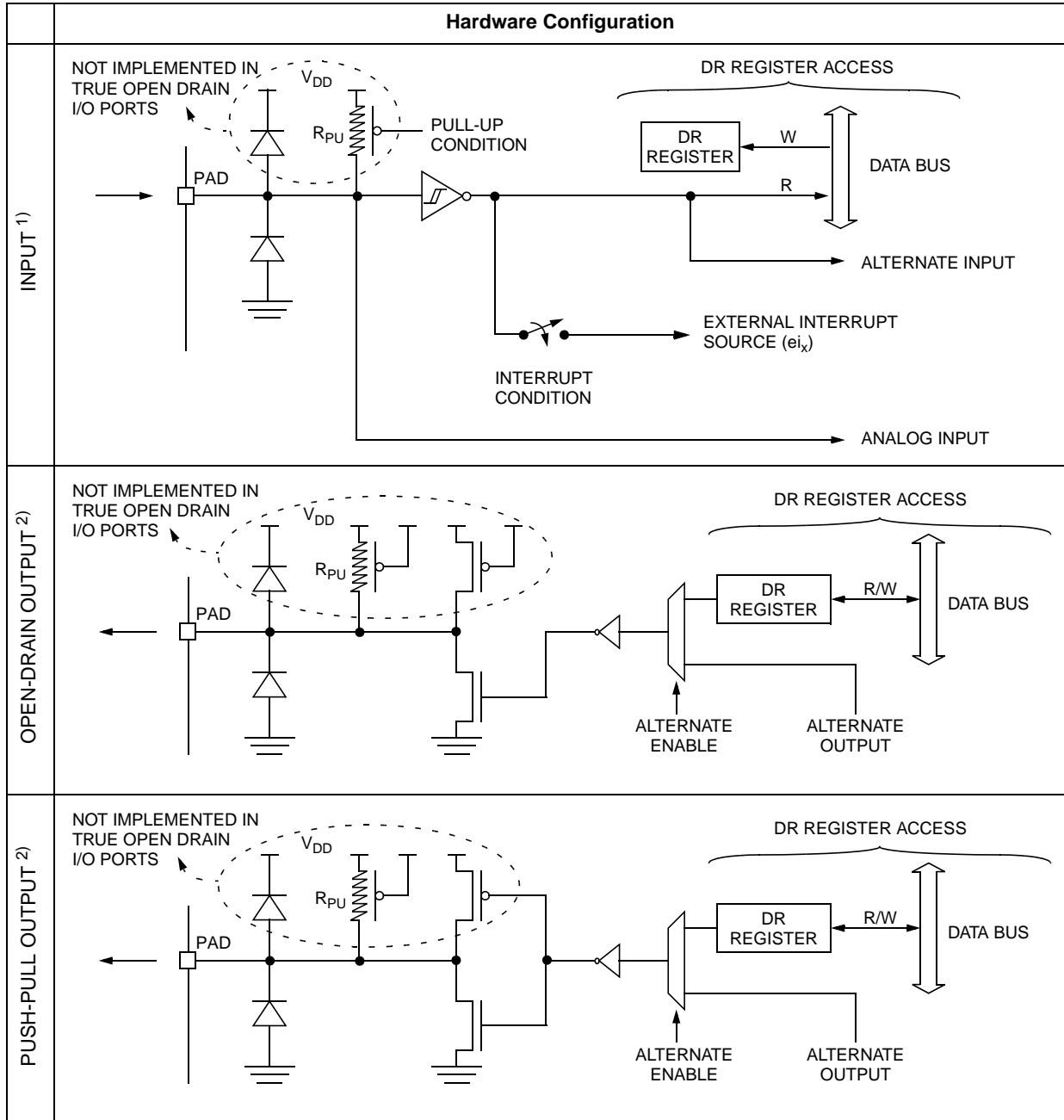

Notes:

1. When the I/O port is in input configuration and the associated alternate function is enabled as an output, reading the DR register will read the alternate function output status.
2. When the I/O port is in output configuration and the associated alternate function is enabled as an input, the alternate function reads the pin status given by the DR register content.

I/O PORTS (Cont'd)

CAUTION: The alternate function must not be activated as long as the pin is configured as input with interrupt, in order to avoid generating spurious interrupts.

Analog alternate function

When the pin is used as an ADC input, the I/O must be configured as floating input. The analog multiplexer (controlled by the ADC registers) switches the analog voltage present on the selected pin to the common analog rail which is connected to the ADC input.

It is recommended not to change the voltage level or loading on any port pin while conversion is in progress. Furthermore it is recommended not to have clocking pins located close to a selected analog pin.

WARNING: The analog input voltage level must be within the limits stated in the absolute maximum ratings.

9.3 I/O PORT IMPLEMENTATION

The hardware implementation on each I/O port depends on the settings in the DDR and OR registers and specific feature of the I/O port such as ADC Input or true open drain.

Switching these I/O ports from one state to another should be done in a sequence that prevents unwanted side effects. Recommended safe transitions are illustrated in [Figure 31](#) Other transitions are potentially risky and should be avoided, since they are likely to present unwanted side-effects such as spurious interrupt generation.

Figure 31. Interrupt I/O Port State Transitions

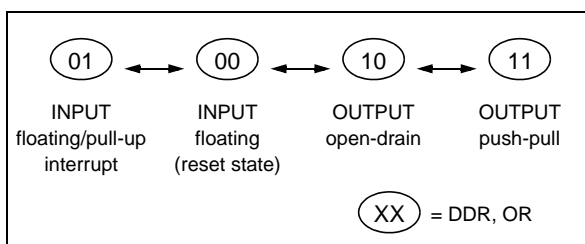

9.4 LOW POWER MODES

Mode	Description
WAIT	No effect on I/O ports. External interrupts cause the device to exit from WAIT mode.
HALT	No effect on I/O ports. External interrupts cause the device to exit from HALT mode.

9.5 INTERRUPTS

The external interrupt event generates an interrupt if the corresponding configuration is selected with DDR and OR registers and the interrupt mask in the CC register is not active (RIM instruction).

Interrupt Event	Event Flag	Enable Control Bit	Exit from Wait	Exit from Halt
External interrupt on selected external event	-	DDR _x OR _x	Yes	Yes

I/O PORTS (Cont'd)

9.5.1 I/O Port Implementation

The I/O port register configurations are summarised as follows.

Standard Ports

PA5:4, PC7:0, PD7:0, PE7:34, PE1:0, PF7:3, PG7:0, PH7:0

MODE	DDR	OR
floating input	0	0
pull-up input	0	1
open drain output	1	0
push-pull output	1	1

Interrupt Ports

PA2:0, PB6:5, PB4, PB2:0, PF1:0 (with pull-up)

MODE	DDR	OR
floating input	0	0
pull-up interrupt input	0	1
open drain output	1	0
push-pull output	1	1

PA3, PB7, PB3, PF2 (without pull-up)

MODE	DDR	OR
floating input	0	0
floating interrupt input	0	1
open drain output	1	0
push-pull output	1	1

True Open Drain Ports

PA7:6

MODE	DDR
floating input	0
open drain (high sink ports)	1

Pull-up Input Port (CANTX requirement)

PE2

MODE
pull-up input

Table 11. Port Configuration

Port	Pin name	Input		Output	
		OR = 0	OR = 1	OR = 0	OR = 1
Port A	PA7:6	floating		true open-drain	
	PA5:4	floating	pull-up	open drain	push-pull
	PA3	floating	floating interrupt	open drain	push-pull
	PA2:0	floating	pull-up interrupt	open drain	push-pull
Port B	PB7, PB3	floating	floating interrupt	open drain	push-pull
	PB6:5, PB4, PB2:0	floating	pull-up interrupt	open drain	push-pull
Port C	PC7:0	floating	pull-up	open drain	push-pull
Port D	PD7:0	floating	pull-up	open drain	push-pull
Port E	PE7:3, PE1:0	floating	pull-up	open drain	push-pull
	PE2	pull-up input only *			
Port F	PF7:3	floating	pull-up	open drain	push-pull
	PF2	floating	floating interrupt	open drain	push-pull
	PF1:0	floating	pull-up interrupt	open drain	push-pull
Port G	PG7:0	floating	pull-up	open drain	push-pull
Port H	PH7:0	floating	pull-up	open drain	push-pull

* Note: when the CANTX alternate function is selected the I/O port operates in output push-pull mode.

I/O PORTS (Cont'd)

Table 12. I/O Port Register Map and Reset Values

Address (Hex.)	Register Label	7	6	5	4	3	2	1	0
Reset Value of all I/O port registers		0	0	0	0	0	0	0	0
0000h	PADR	MSB							LSB
0001h	PADDR								
0002h	PAOR								
0003h	PBDR	MSB							LSB
0004h	PBDDR								
0005h	PBOR								
0006h	PCDR	MSB							LSB
0007h	PCDDR								
0008h	PCOR								
0009h	PDDR	MSB							LSB
000Ah	PDDDR								
000Bh	PDOR								
000Ch	PEDR	MSB							LSB
000Dh	PEDDR								
000Eh	PEOR								
000Fh	PFDR	MSB							LSB
0010h	PFDDR								
0011h	PFOR								
0012h	PGDR	MSB							LSB
0013h	PGDDR								
0014h	PGOR								
0015h	PHDR	MSB							LSB
0016h	PHDDR								
0017h	PHOR								

Related Documentation

AN 970: SPI Communication between ST7 and EEPROM

AN1045: S/W implementation of I2C bus master

AN1048: Software LCD driver

10 ON-CHIP PERIPHERALS

10.1 WATCHDOG TIMER (WDG)

10.1.1 Introduction

The Watchdog timer is used to detect the occurrence of a software fault, usually generated by external interference or by unforeseen logical conditions, which causes the application program to abandon its normal sequence. The Watchdog circuit generates an MCU reset on expiry of a programmed time period, unless the program refreshes the counter's contents before the T6 bit becomes cleared.

10.1.2 Main Features

- Programmable free-running downcounter
- Programmable reset
- Reset (if watchdog activated) when the T6 bit reaches zero
- Optional reset on HALT instruction (configurable by option byte)
- Hardware Watchdog selectable by option byte

10.1.3 Functional Description

The counter value stored in the Watchdog Control register (WDGCR bits T[6:0]), is decremented every $16384 f_{OSC2}$ cycles (approx.), and the length of the timeout period can be programmed by the user in 64 increments.

If the watchdog is activated (the WDGA bit is set) and when the 7-bit timer (bits T[6:0]) rolls over from 40h to 3Fh (T6 becomes cleared), it initiates a reset cycle pulling low the reset pin for typically 500ns.

The application program must write in the WDGCR register at regular intervals during normal operation to prevent an MCU reset. This downcounter is free-running: it counts down even if the watchdog is disabled. The value to be stored in the WDGCR register must be between FFh and C0h:

- The WDGA bit is set (watchdog enabled)
- The T6 bit is set to prevent generating an immediate reset
- The T[5:0] bits contain the number of increments which represents the time delay before the watchdog produces a reset (see [Figure 33. Approximate Timeout Duration](#)). The timing varies between a minimum and a maximum value due to the unknown status of the prescaler when writing to the WDGCR register (see [Figure 34](#)).

Following a reset, the watchdog is disabled. Once activated it cannot be disabled, except by a reset.

The T6 bit can be used to generate a software reset (the WDGA bit is set and the T6 bit is cleared).

If the watchdog is activated, the HALT instruction will generate a Reset.

Figure 32. Watchdog Block Diagram

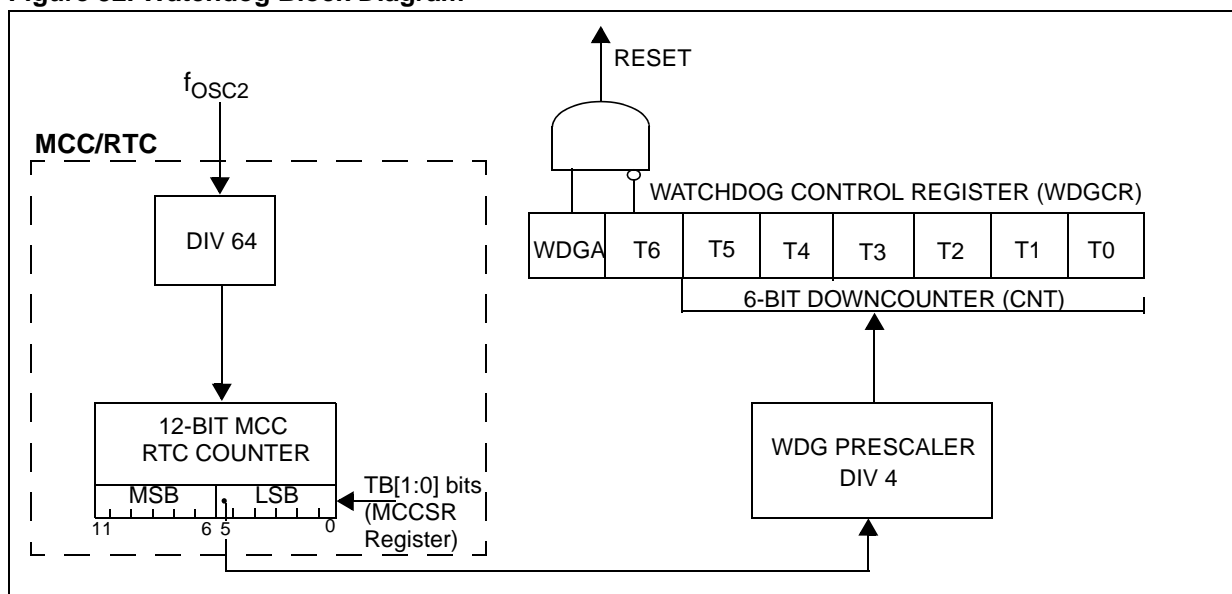

WATCHDOG TIMER (Cont'd)

10.1.4 How to Program the Watchdog Timeout

Figure 33 shows the linear relationship between the 6-bit value to be loaded in the Watchdog Counter (CNT) and the resulting timeout duration in milliseconds. This can be used for a quick calculation without taking the timing variations into account. If

more precision is needed, use the formulae in Figure 34.

Caution: When writing to the WDGCR register, always write 1 in the T6 bit to avoid generating an immediate reset.

Figure 33. Approximate Timeout Duration

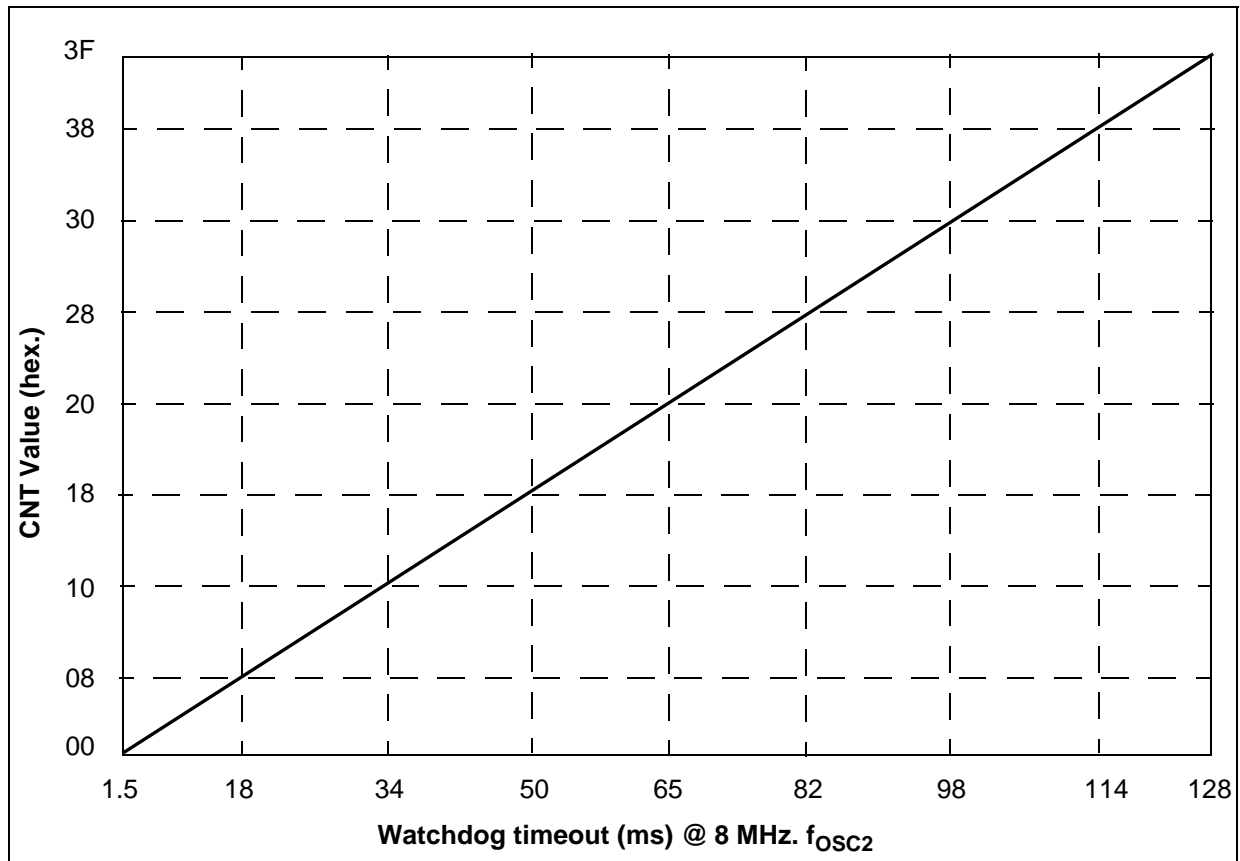

WATCHDOG TIMER (Cont'd)

Figure 34. Exact Timeout Duration (t_{min} and t_{max})**WHERE:**

$$t_{min0} = (LSB + 128) \times 64 \times t_{OSC2}$$

$$t_{max0} = 16384 \times t_{OSC2}$$

$$t_{OSC2} = 125\text{ns if } f_{OSC2}=8 \text{ MHz}$$

CNT = Value of T[5:0] bits in the WDGCR register (6 bits)

MSB and LSB are values from the table below depending on the timebase selected by the TB[1:0] bits in the MCCSR register

TB1 Bit (MCCSR Reg.)	TB0 Bit (MCCSR Reg.)	Selected MCCSR Timebase	MSB	LSB
0	0	2ms	4	59
0	1	4ms	8	53
1	0	10ms	20	35
1	1	25ms	49	54

To calculate the minimum Watchdog Timeout (t_{min}):

$$\text{IF } CNT < \left\lfloor \frac{MSB}{4} \right\rfloor \quad \text{THEN } t_{min} = t_{min0} + 16384 \times CNT \times t_{osc2}$$

$$\text{ELSE } t_{min} = t_{min0} + \left[16384 \times \left(CNT - \left\lfloor \frac{4CNT}{MSB} \right\rfloor \right) + (192 + LSB) \times 64 \times \left\lfloor \frac{4CNT}{MSB} \right\rfloor \right] \times t_{osc2}$$

To calculate the maximum Watchdog Timeout (t_{max}):

$$\text{IF } CNT \leq \left\lfloor \frac{MSB}{4} \right\rfloor \quad \text{THEN } t_{max} = t_{max0} + 16384 \times CNT \times t_{osc2}$$

$$\text{ELSE } t_{max} = t_{max0} + \left[16384 \times \left(CNT - \left\lfloor \frac{4CNT}{MSB} \right\rfloor \right) + (192 + LSB) \times 64 \times \left\lfloor \frac{4CNT}{MSB} \right\rfloor \right] \times t_{osc2}$$

Note: In the above formulae, division results must be rounded down to the next integer value.

Example:

With 2ms timeout selected in MCCSR register

Value of T[5:0] Bits in WDGCR Register (Hex.)	Min. Watchdog Timeout (ms)	Max. Watchdog Timeout (ms)
	t_{min}	t_{max}
00	1.496	2.048
3F	128	128.552

WATCHDOG TIMER (Cont'd)

10.1.5 Low Power Modes

Mode	Description		
SLOW	No effect on Watchdog.		
WAIT	No effect on Watchdog.		
HALT	OIE bit in MCSR register	WDGHALT bit in Option Byte	
	0	0	No Watchdog reset is generated. The MCU enters Halt mode. The Watchdog counter is decremented once and then stops counting and is no longer able to generate a watchdog reset until the MCU receives an external interrupt or a reset. If an external interrupt is received, the Watchdog restarts counting after 256 or 4096 CPU clocks. If a reset is generated, the Watchdog is disabled (reset state) unless Hardware Watchdog is selected by option byte. For application recommendations see Section 10.1.7 below.
	0	1	A reset is generated.
	1	x	No reset is generated. The MCU enters Active Halt mode. The Watchdog counter is not decremented. It stop counting. When the MCU receives an oscillator interrupt or external interrupt, the Watchdog restarts counting immediately. When the MCU receives a reset the Watchdog restarts counting after 256 or 4096 CPU clocks.

10.1.6 Hardware Watchdog Option

If Hardware Watchdog is selected by option byte, the watchdog is always active and the WDGA bit in the WDGCR is not used. Refer to the Option Byte description.

10.1.7 Using Halt Mode with the WDG (WDGHALT option)

The following recommendation applies if Halt mode is used when the watchdog is enabled.

- Before executing the HALT instruction, refresh the WDG counter, to avoid an unexpected WDG reset immediately after waking up the microcontroller.

10.1.8 Interrupts

None.

10.1.9 Register Description

CONTROL REGISTER (WDGCR)

Read/Write

Reset Value: 0111 1111 (7Fh)

7							0
WDGA	T6	T5	T4	T3	T2	T1	T0

Bit 7 = **WDGA** Activation bit.

This bit is set by software and only cleared by hardware after a reset. When WDGA = 1, the watchdog can generate a reset.

0: Watchdog disabled

1: Watchdog enabled

Note: This bit is not used if the hardware watchdog option is enabled by option byte.

Bit 6:0 = **T[6:0]** 7-bit counter (MSB to LSB).

These bits contain the value of the watchdog counter. It is decremented every 16384 f_{OSC2} cycles (approx.). A reset is produced when it rolls over from 40h to 3Fh (T6 becomes cleared).

Table 13. Watchdog Timer Register Map and Reset Values

Address (Hex.)	Register Label	7	6	5	4	3	2	1	0
002Ah	WDGCR Reset Value	WDGA 0	T6 1	T5 1	T4 1	T3 1	T2 1	T1 1	T0 1

10.2 MAIN CLOCK CONTROLLER WITH REAL TIME CLOCK AND BEEPER (MCC/RTC)

The Main Clock Controller consists of three different functions:

- a programmable CPU clock prescaler
- a clock-out signal to supply external devices
- a real time clock timer with interrupt capability

Each function can be used independently and simultaneously.

10.2.1 Programmable CPU Clock Prescaler

The programmable CPU clock prescaler supplies the clock for the ST7 CPU and its internal peripherals. It manages SLOW power saving mode (See Section 8.2 SLOW MODE for more details).

The prescaler selects the f_{CPU} main clock frequency and is controlled by three bits in the MCCR register: CP[1:0] and SMS.

10.2.2 Clock-out Capability

The clock-out capability is an alternate function of an I/O port pin that outputs a f_{CPU} clock to drive

external devices. It is controlled by the MCO bit in the MCCR register.

CAUTION: When selected, the clock out pin suspends the clock during ACTIVE-HALT mode.

10.2.3 Real Time Clock Timer (RTC)

The counter of the real time clock timer allows an interrupt to be generated based on an accurate real time clock. Four different time bases depending directly on f_{OSC2} are available. The whole functionality is controlled by four bits of the MCCR register: TB[1:0], OIE and OIF.

When the RTC interrupt is enabled (OIE bit set), the ST7 enters ACTIVE-HALT mode when the HALT instruction is executed. See Section 8.4 ACTIVE-HALT AND HALT MODES for more details.

10.2.4 Beeper

The beep function is controlled by the MCCBCR register. It can output three selectable frequencies on the BEEP pin (I/O port alternate function).

Figure 35. Main Clock Controller (MCC/RTC) Block Diagram

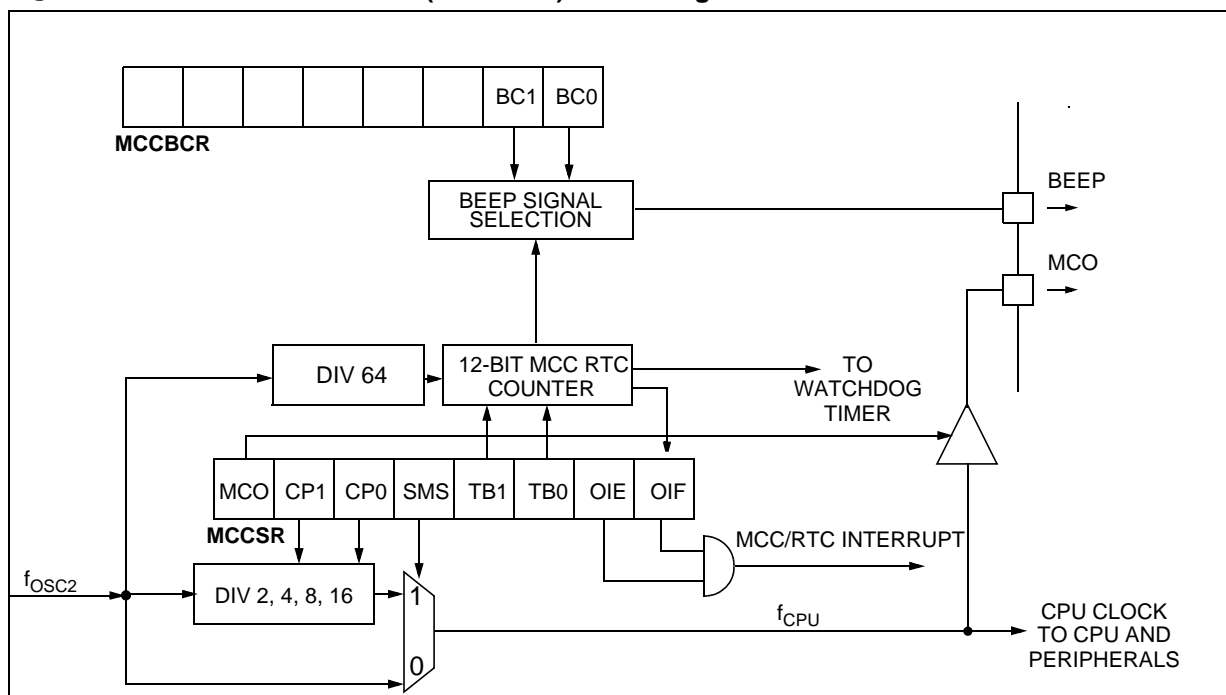

MAIN CLOCK CONTROLLER WITH REAL TIME CLOCK (Cont'd)

10.2.5 Low Power Modes

Mode	Description
WAIT	No effect on MCC/RTC peripheral. MCC/RTC interrupt cause the device to exit from WAIT mode.
ACTIVE-HALT	No effect on MCC/RTC counter (OIE bit is set), the registers are frozen. MCC/RTC interrupt cause the device to exit from ACTIVE-HALT mode.
HALT	MCC/RTC counter and registers are frozen. MCC/RTC operation resumes when the MCU is woken up by an interrupt with "exit from HALT" capability.

10.2.6 Interrupts

The MCC/RTC interrupt event generates an interrupt if the OIE bit of the MCCR register is set and the interrupt mask in the CC register is not active (RIM instruction).

Interrupt Event	Event Flag	Enable Control Bit	Exit from Wait	Exit from Halt
Time base overflow event	OIF	OIE	Yes	No ¹⁾

Note:

The MCC/RTC interrupt wakes up the MCU from ACTIVE-HALT mode, not from HALT mode.

10.2.7 Register Description

MCC CONTROL/STATUS REGISTER (MCCR)

Read/Write

Reset Value: 0000 0000 (00h)

7							0
MCO	CP1	CP0	SMS	TB1	TB0	OIE	OIF

Bit 7 = MCO Main clock out selection

This bit enables the MCO alternate function on the PF0 I/O port. It is set and cleared by software.

0: MCO alternate function disabled (I/O pin free for general-purpose I/O)

1: MCO alternate function enabled (f_{CPU} on I/O port)

Note: To reduce power consumption, the MCO function is not active in ACTIVE-HALT mode.

Bit 6:5 = CP[1:0] CPU clock prescaler

These bits select the CPU clock prescaler which is applied in the different slow modes. Their action is conditioned by the setting of the SMS bit. These two bits are set and cleared by software

f_{CPU} in SLOW mode	CP1	CP0
$f_{OSC2} / 2$	0	0
$f_{OSC2} / 4$	0	1
$f_{OSC2} / 8$	1	0
$f_{OSC2} / 16$	1	1

Bit 4 = SMS Slow mode select

This bit is set and cleared by software.

0: Normal mode. $f_{CPU} = f_{OSC2}$

1: Slow mode. f_{CPU} is given by CP1, CP0

See [Section 8.2 SLOW MODE](#) and [Section 10.2 MAIN CLOCK CONTROLLER WITH REAL TIME CLOCK AND BEEPER \(MCC/RTC\)](#) for more details.

Bit 3:2 = TB[1:0] Time base control

These bits select the programmable divider time base. They are set and cleared by software.

Counter Prescaler	Time Base		TB1	TB0
	$f_{OSC2}=4MHz$	$f_{OSC2}=8MHz$		
16000	4ms	2ms	0	0
32000	8ms	4ms	0	1
80000	20ms	10ms	1	0
200000	50ms	25ms	1	1

A modification of the time base is taken into account at the end of the current period (previously set) to avoid an unwanted time shift. This allows to use this time base as a real time clock.

Bit 1 = OIE Oscillator interrupt enable

This bit set and cleared by software.

0: Oscillator interrupt disabled

1: Oscillator interrupt enabled

This interrupt can be used to exit from ACTIVE-HALT mode.

When this bit is set, calling the ST7 software HALT instruction enters the ACTIVE-HALT power saving mode.

MAIN CLOCK CONTROLLER WITH REAL TIME CLOCK (Cont'd)

Bit 0 = **OIF** *Oscillator interrupt flag*

This bit is set by hardware and cleared by software reading the MCCR register. It indicates when set that the main oscillator has reached the selected elapsed time (TB1:0).

0: Timeout not reached

1: Timeout reached

CAUTION: The BRES and BSET instructions must not be used on the MCCR register to avoid unintentionally clearing the OIF bit.

MCC BEEP CONTROL REGISTER (MCCBCR)

Read/Write

Reset Value: 0000 0000 (00h)

7							0
0	0	0	0	0	0	BC1	BC0

Bit 7:2 = Reserved, must be kept cleared.

Bit 1:0 = **BC[1:0]** *Beep control*

These 2 bits select the PF1 pin beep capability.

BC1	BC0	Beep mode with f _{OSC2} =8MHz	
0	0	Off	
0	1	~2-KHz	Output Beep signal ~50% duty cycle
1	0	~1-KHz	
1	1	~500-Hz	

The beep output signal is available in ACTIVE-HALT mode but has to be disabled to reduce the consumption.

Table 14. Main Clock Controller Register Map and Reset Values

Address (Hex.)	Register Label	7	6	5	4	3	2	1	0
002Bh	SICSR Reset Value	AVDS 0	AVDIE 0	AVDF 0	LVDRF x	0	0	0	WDGRF x
002Ch	MCCSR Reset Value	MCO 0	CP1 0	CP0 0	SMS 0	TB1 0	TB0 0	OIE 0	OIF 0
002Dh	MCCBCR Reset Value	0	0	0	0	0	0	BC1 0	BC0 0

10.3 PWM AUTO-RELOAD TIMER (ART)

10.3.1 Introduction

The Pulse Width Modulated Auto-Reload Timer on-chip peripheral consists of an 8-bit auto reload counter with compare/capture capabilities and of a 7-bit prescaler clock source.

These resources allow five possible operating modes:

- Generation of up to 4 independent PWM signals
- Output compare and Time base interrupt

- Up to two input capture functions
- External event detector
- Up to two external interrupt sources

The three first modes can be used together with a single counter frequency.

The timer can be used to wake up the MCU from WAIT and HALT modes.

Figure 36. PWM Auto-Reload Timer Block Diagram

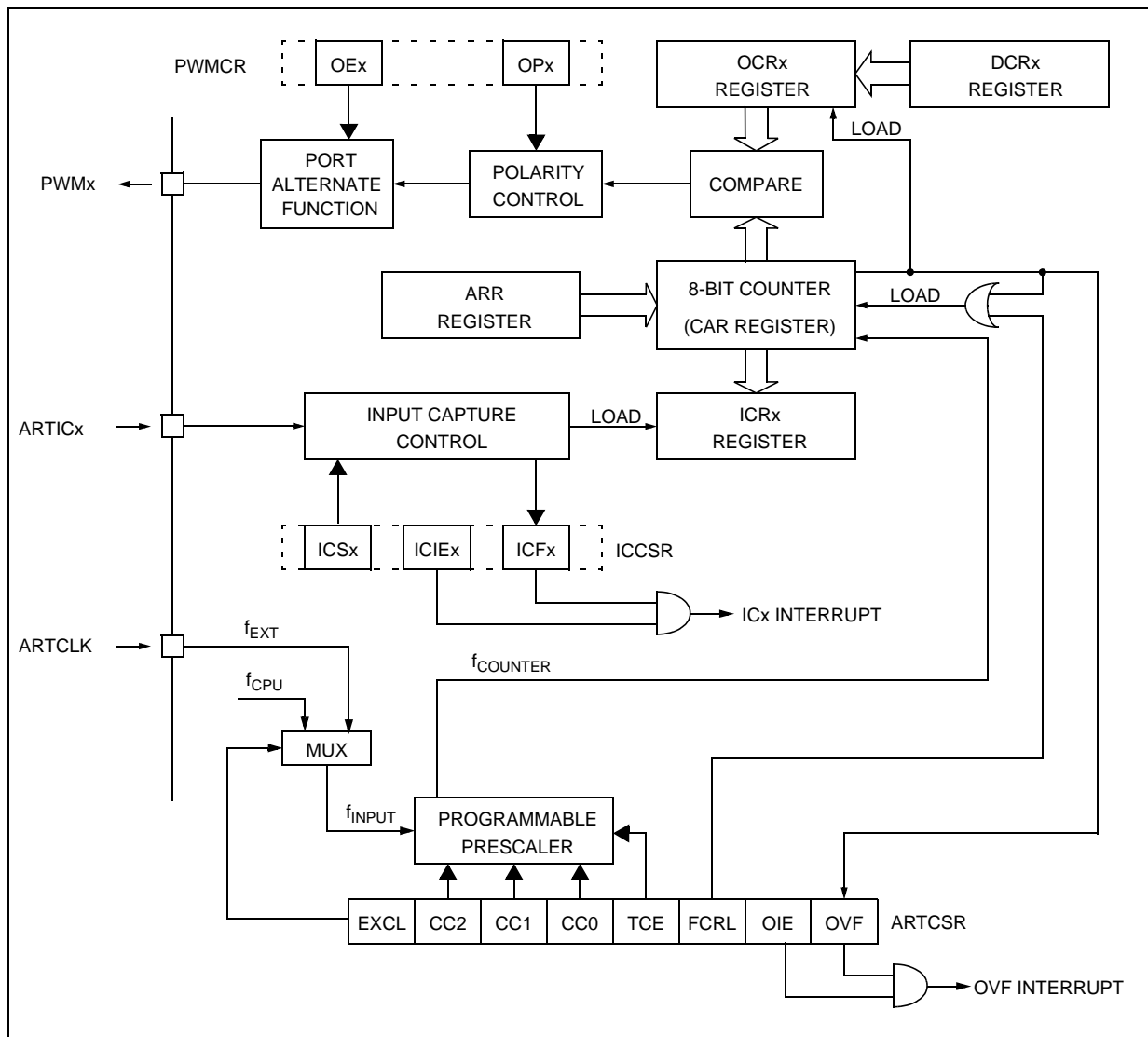

PWM AUTO-RELOAD TIMER (Cont'd)

10.3.2 Functional Description

Counter

The free running 8-bit counter is fed by the output of the prescaler, and is incremented on every rising edge of the clock signal.

It is possible to read or write the contents of the counter on the fly by reading or writing the Counter Access register (ARTCAR).

When a counter overflow occurs, the counter is automatically reloaded with the contents of the ARTARR register (the prescaler is not affected).

Counter clock and prescaler

The counter clock frequency is given by:

$$f_{\text{COUNTER}} = f_{\text{INPUT}} / 2^{\text{CC}[2:0]}$$

The timer counter's input clock (f_{INPUT}) feeds the 7-bit programmable prescaler, which selects one of the 8 available taps of the prescaler, as defined by CC[2:0] bits in the Control/Status Register (ARTCSR). Thus the division factor of the prescaler can be set to 2^n (where $n = 0, 1, \dots, 7$).

This f_{INPUT} frequency source is selected through the EXCL bit of the ARTCSR register and can be either the f_{CPU} or an external input frequency f_{EXT} . The clock input to the counter is enabled by the TCE (Timer Counter Enable) bit in the ARTCSR register. When TCE is reset, the counter is stopped and the prescaler and counter contents are frozen. When TCE is set, the counter runs at the rate of the selected clock source.

Counter and Prescaler Initialization

After RESET, the counter and the prescaler are cleared and $f_{\text{INPUT}} = f_{\text{CPU}}$.

The counter can be initialized by:

- Writing to the ARTARR register and then setting the FCRL (Force Counter Re-Load) and the TCE (Timer Counter Enable) bits in the ARTCSR register.
- Writing to the ARTCAR counter access register, In both cases the 7-bit prescaler is also cleared, whereupon counting will start from a known value. Direct access to the prescaler is not possible.

Output compare control

The timer compare function is based on four different comparisons with the counter (one for each PWMx output). Each comparison is made between the counter value and an output compare register (OCRx) value. This OCRx register can not be accessed directly, it is loaded from the duty cycle register (PWMDCRx) at each overflow of the counter.

This double buffering method avoids glitch generation when changing the duty cycle on the fly.

Figure 37. Output compare control

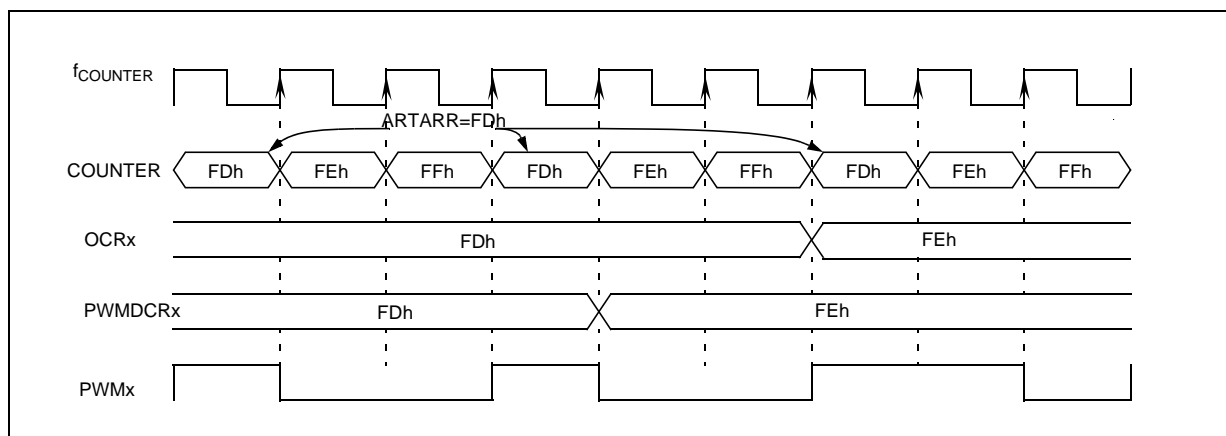

PWM AUTO-RELOAD TIMER (Cont'd)

Independent PWM signal generation

This mode allows up to four Pulse Width Modulated signals to be generated on the PWMx output pins with minimum core processing overhead. This function is stopped during HALT mode.

Each PWMx output signal can be selected independently using the corresponding OEx bit in the PWM Control register (PWMCR). When this bit is set, the corresponding I/O pin is configured as output push-pull alternate function.

The PWM signals all have the same frequency which is controlled by the counter period and the ARTARR register value.

$$f_{PWM} = f_{COUNTER} / (256 - ARTARR)$$

When a counter overflow occurs, the PWMx pin level is changed depending on the corresponding OPx (output polarity) bit in the PWMCR register.

When the counter reaches the value contained in one of the output compare register (OCRx) the corresponding PWMx pin level is restored.

It should be noted that the reload values will also affect the value and the resolution of the duty cycle of the PWM output signal. To obtain a signal on a PWMx pin, the contents of the OCRx register must be greater than the contents of the ARTARR register.

The maximum available resolution for the PWMx duty cycle is:

$$\text{Resolution} = 1 / (256 - ARTARR)$$

Note: To get the maximum resolution (1/256), the ARTARR register must be 0. With this maximum resolution, 0% and 100% can be obtained by changing the polarity.

Figure 38. PWM Auto-reload Timer Function

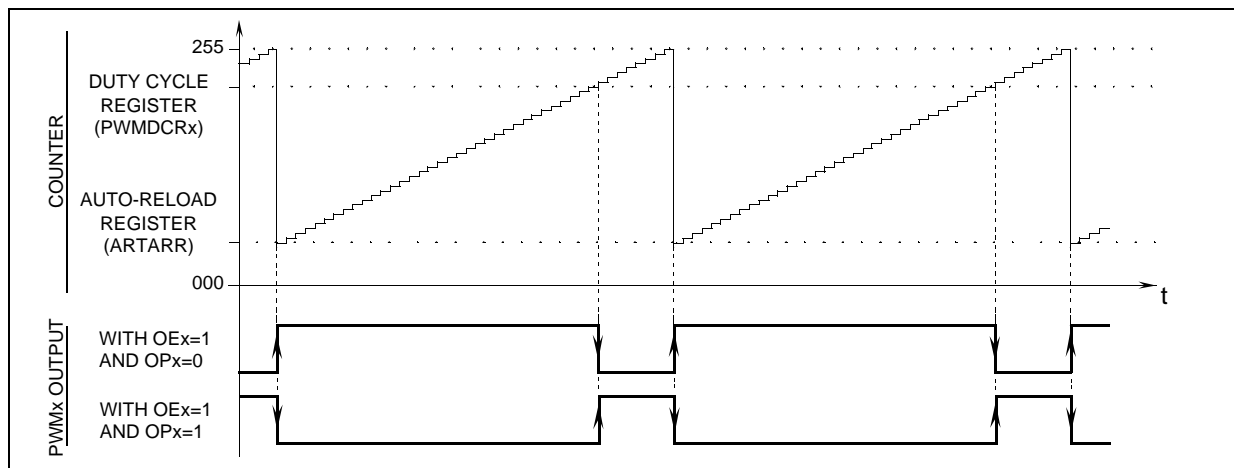
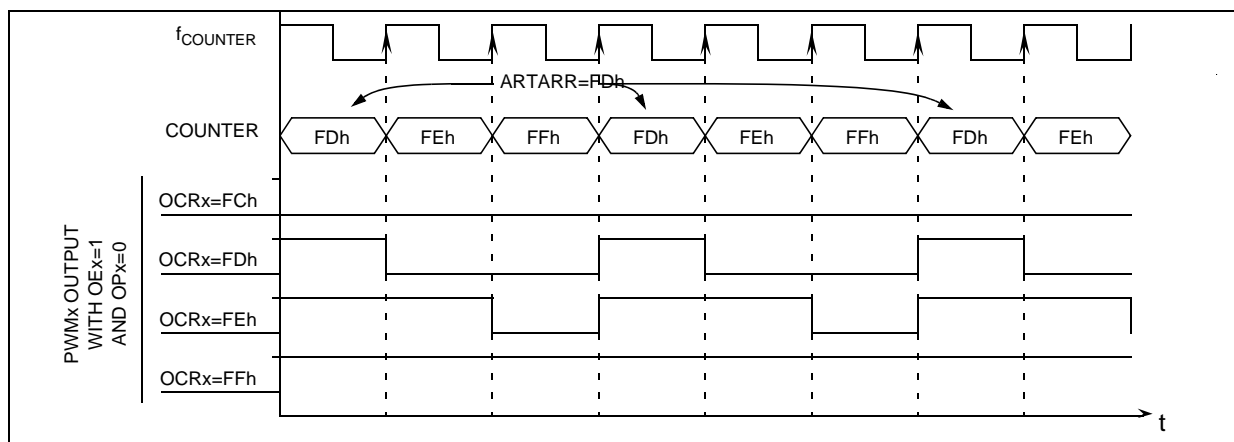

Figure 39. PWM Signal from 0% to 100% Duty Cycle



PWM AUTO-RELOAD TIMER (Cont'd)

Output compare and Time base interrupt

On overflow, the OVF flag of the ARTCSR register is set and an overflow interrupt request is generated if the overflow interrupt enable bit, OIE, in the ARTCSR register, is set. The OVF flag must be reset by the user software. This interrupt can be used as a time base in the application.

External clock and event detector mode

Using the f_{EXT} external prescaler input clock, the auto-reload timer can be used as an external clock event detector. In this mode, the ARTARR register is used to select the n_{EVENT} number of events to be counted before setting the OVF flag.

$$n_{EVENT} = 256 - ARTARR$$

Caution: The external clock function is not available in HALT mode. If HALT mode is used in the application, prior to executing the HALT instruction, the counter must be disabled by clearing the TCE bit in the ARTCSR register to avoid spurious counter increments.

Figure 40. External Event Detector Example (3 counts)

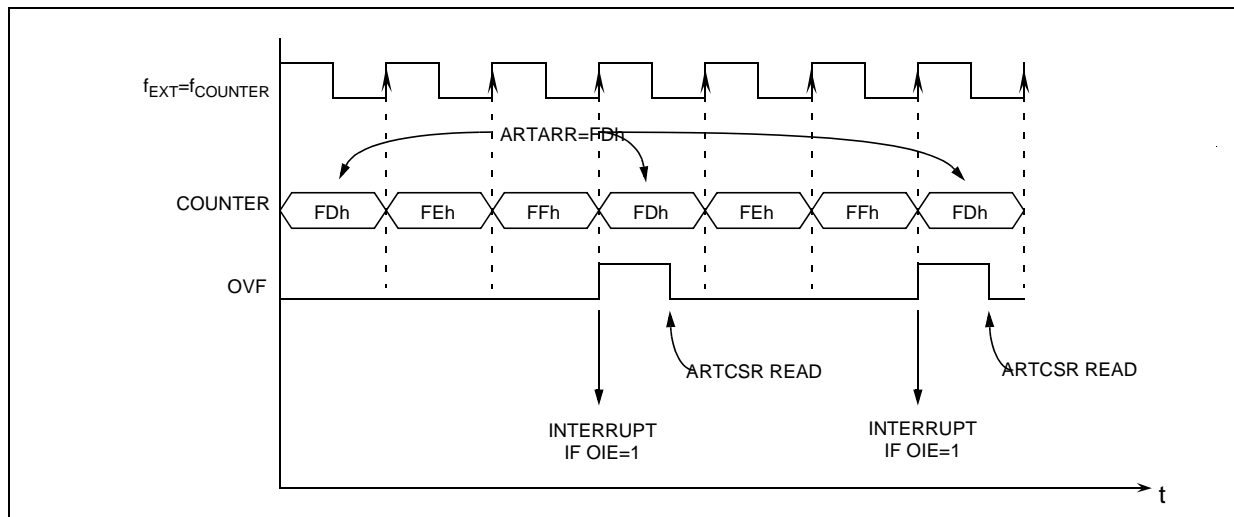

PWM AUTO-RELOAD TIMER (Cont'd)

Input capture function

This mode allows the measurement of external signal pulse widths through ARTICRx registers.

Each input capture can generate an interrupt independently on a selected input signal transition. This event is flagged by a set of the corresponding CFx bits of the Input Capture Control/Status register (ARTICCSR).

These input capture interrupts are enabled through the CIEx bits of the ARTICCSR register.

The active transition (falling or rising edge) is software programmable through the CSx bits of the ARTICCSR register.

The read only input capture registers (ARTICRx) are used to latch the auto-reload counter value when a transition is detected on the ARTICx pin (CFx bit set in ARTICCSR register). After fetching the interrupt vector, the CFx flags can be read to identify the interrupt source.

Note: After a capture detection, data transfer in the ARTICRx register is inhibited until it is read (clearing the CFx bit).

The timer interrupt remains pending while the CFx flag is set when the interrupt is enabled (CIEx bit set). This means, the ARTICRx register has to be read at each capture event to clear the CFx flag.

The timing resolution is given by auto-reload counter cycle time ($1/f_{\text{COUNTER}}$).

Note: During HALT mode, if both input capture and external clock are enabled, the ARTICRx register value is not guaranteed if the input capture pin and the external clock change simultaneously.

Figure 41. Input Capture Timing Diagram

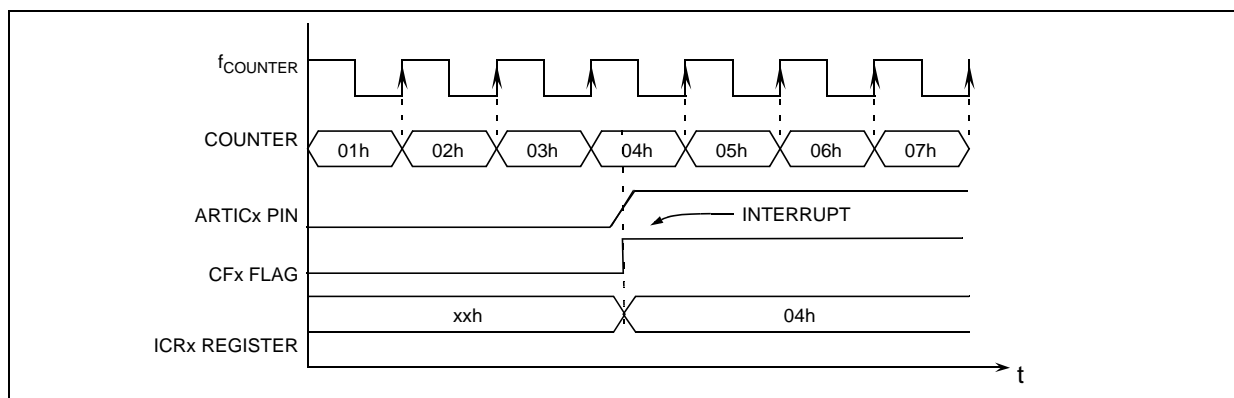

External interrupt capability

This mode allows the Input capture capabilities to be used as external interrupt sources. The interrupts are generated on the edge of the ARTICx signal.

The edge sensitivity of the external interrupts is programmable (CSx bit of ARTICCSR register) and they are independently enabled through CIEx bits of the ARTICCSR register. After fetching the interrupt vector, the CFx flags can be read to identify the interrupt source.

During HALT mode, the external interrupts can be used to wake up the micro (if the CIEx bit is set).

PWM AUTO-RELOAD TIMER (Cont'd)

10.3.3 Register Description

CONTROL / STATUS REGISTER (ARTCSR)

Read/Write

Reset Value: 0000 0000 (00h)

7	0						
EXCL	CC2	CC1	CC0	TCE	FCRL	OIE	OVF

Bit 7 = **EXCL** External Clock

This bit is set and cleared by software. It selects the input clock for the 7-bit prescaler.

0: CPU clock.

1: External clock.

Bit 6:4 = **CC[2:0]** Counter Clock Control

These bits are set and cleared by software. They determine the prescaler division ratio from f_{INPUT} .

$f_{COUNTER}$	With $f_{INPUT}=8$ MHz	CC2	CC1	CC0
f_{INPUT}	8 MHz	0	0	0
$f_{INPUT} / 2$	4 MHz	0	0	1
$f_{INPUT} / 4$	2 MHz	0	1	0
$f_{INPUT} / 8$	1 MHz	0	1	1
$f_{INPUT} / 16$	500 KHz	1	0	0
$f_{INPUT} / 32$	250 KHz	1	0	1
$f_{INPUT} / 64$	125 KHz	1	1	0
$f_{INPUT} / 128$	62.5 KHz	1	1	1

Bit 3 = **TCE** Timer Counter Enable

This bit is set and cleared by software. It puts the timer in the lowest power consumption mode.

0: Counter stopped (prescaler and counter frozen).

1: Counter running.

Bit 2 = **FCRL** Force Counter Re-Load

This bit is write-only and any attempt to read it will yield a logical zero. When set, it causes the contents of ARTARR register to be loaded into the counter, and the content of the prescaler register to be cleared in order to initialize the timer before starting to count.

Bit 1 = **OIE** Overflow Interrupt Enable

This bit is set and cleared by software. It allows to enable/disable the interrupt which is generated when the OVF bit is set.

0: Overflow Interrupt disable.

1: Overflow Interrupt enable.

Bit 0 = **OVF** Overflow Flag

This bit is set by hardware and cleared by software reading the ARTCSR register. It indicates the transition of the counter from FFh to the ARTARR value.

0: New transition not yet reached

1: Transition reached

COUNTER ACCESS REGISTER (ARTCAR)

Read/Write

Reset Value: 0000 0000 (00h)

7	0						
CA7	CA6	CA5	CA4	CA3	CA2	CA1	CA0

Bit 7:0 = **CA[7:0]** Counter Access Data

These bits can be set and cleared either by hardware or by software. The ARTCAR register is used to read or write the auto-reload counter “on the fly” (while it is counting).

AUTO-RELOAD REGISTER (ARTARR)

Read/Write

Reset Value: 0000 0000 (00h)

7	0						
AR7	AR6	AR5	AR4	AR3	AR2	AR1	AR0

Bit 7:0 = **AR[7:0]** Counter Auto-Reload Data

These bits are set and cleared by software. They are used to hold the auto-reload value which is automatically loaded in the counter when an overflow occurs. At the same time, the PWM output levels are changed according to the corresponding OPx bit in the PWMCR register.

This register has two PWM management functions:

- Adjusting the PWM frequency
- Setting the PWM duty cycle resolution

PWM Frequency vs. Resolution:

ARTARR value	Resolution	f_{PWM}	
		Min	Max
0	8-bit	~0.244-KHz	31.25-KHz
[0..127]	> 7-bit	~0.244-KHz	62.5-KHz
[128..191]	> 6-bit	~0.488-KHz	125-KHz
[192..223]	> 5-bit	~0.977-KHz	250-KHz
[224..239]	> 4-bit	~1.953-KHz	500-KHz

PWM AUTO-RELOAD TIMER (Cont'd)**PWM CONTROL REGISTER (PWMCR)**

Read/Write

Reset Value: 0000 0000 (00h)

7							0
OE3	OE2	OE1	OE0	OP3	OP2	OP1	OP0

Bit 7:4 = **OE[3:0]** *PWM Output Enable*

These bits are set and cleared by software. They enable or disable the PWM output channels independently acting on the corresponding I/O pin.

0: PWM output disabled.

1: PWM output enabled.

Bit 3:0 = **OP[3:0]** *PWM Output Polarity*

These bits are set and cleared by software. They independently select the polarity of the four PWM output signals.

PWMx output level		OPx
Counter ≤ OCRx	Counter > OCRx	
1	0	0
0	1	1

Note: When an OPx bit is modified, the PWMx output signal polarity is immediately reversed.

DUTY CYCLE REGISTERS (PWMDCRx)

Read/Write

Reset Value: 0000 0000 (00h)

7							0
DC7	DC6	DC5	DC4	DC3	DC2	DC1	DC0

Bit 7:0 = **DC[7:0]** *Duty Cycle Data*

These bits are set and cleared by software.

A PWMDCRx register is associated with the OCRx register of each PWM channel to determine the second edge location of the PWM signal (the first edge location is common to all channels and given by the ARTARR register). These PWMDCR registers allow the duty cycle to be set independently for each PWM channel.

PWM AUTO-RELOAD TIMER (Cont'd)

INPUT CAPTURE CONTROL / STATUS REGISTER (ARTICCSR)

Read/Write

Reset Value: 0000 0000 (00h)

7							0
0	0	CS2	CS1	CIE2	CIE1	CF2	CF1

Bit 7:6 = Reserved, always read as 0.

Bit 5:4 = **CS[2:1] Capture Sensitivity**
 These bits are set and cleared by software. They determine the trigger event polarity on the corresponding input capture channel.
 0: Falling edge triggers capture on channel x.
 1: Rising edge triggers capture on channel x.

Bit 3:2 = **CIE[2:1] Capture Interrupt Enable**
 These bits are set and cleared by software. They enable or disable the Input capture channel interrupts independently.
 0: Input capture channel x interrupt disabled.
 1: Input capture channel x interrupt enabled.

Bit 1:0 = **CF[2:1] Capture Flag**
 These bits are set by hardware and cleared by software reading the corresponding ARTICRx register. Each CFx bit indicates that an input capture x has occurred.
 0: No input capture on channel x.
 1: An input capture has occurred on channel x.

INPUT CAPTURE REGISTERS (ARTICRx)

Read only

Reset Value: 0000 0000 (00h)

7							0
IC7	IC6	IC5	IC4	IC3	IC2	IC1	IC0

Bit 7:0 = **IC[7:0] Input Capture Data**
 These read only bits are set and cleared by hardware. An ARTICRx register contains the 8-bit auto-reload counter value transferred by the input capture channel x event.

PWM AUTO-RELOAD TIMER (Cont'd)

Table 15. PWM Auto-Reload Timer Register Map and Reset Values

Address (Hex.)	Register Label	7	6	5	4	3	2	1	0
0073h	PWMDCR3 Reset Value	DC7 0	DC6 0	DC5 0	DC4 0	DC3 0	DC2 0	DC1 0	DC0 0
0074h	PWMDCR2 Reset Value	DC7 0	DC6 0	DC5 0	DC4 0	DC3 0	DC2 0	DC1 0	DC0 0
0075h	PWMDCR1 Reset Value	DC7 0	DC6 0	DC5 0	DC4 0	DC3 0	DC2 0	DC1 0	DC0 0
0076h	PWMDCR0 Reset Value	DC7 0	DC6 0	DC5 0	DC4 0	DC3 0	DC2 0	DC1 0	DC0 0
0077h	PWMCR Reset Value	OE3 0	OE2 0	OE1 0	OE0 0	OP3 0	OP2 0	OP1 0	OP0 0
0078h	ARTCSR Reset Value	EXCL 0	CC2 0	CC1 0	CC0 0	TCE 0	FCRL 0	RIE 0	OVF 0
0079h	ARTCAR Reset Value	CA7 0	CA6 0	CA5 0	CA4 0	CA3 0	CA2 0	CA1 0	CA0 0
007Ah	ARTARR Reset Value	AR7 0	AR6 0	AR5 0	AR4 0	AR3 0	AR2 0	AR1 0	AR0 0
007Bh	ARTICCSR Reset Value	0	0	CS2 0	CS1 0	CIE2 0	CIE1 0	CF2 0	CF1 0
007Ch	ARTICR1 Reset Value	IC7 0	IC6 0	IC5 0	IC4 0	IC3 0	IC2 0	IC1 0	IC0 0
007Dh	ARTICR2 Reset Value	IC7 0	IC6 0	IC5 0	IC4 0	IC3 0	IC2 0	IC1 0	IC0 0

10.4 16-BIT TIMER

10.4.1 Introduction

The timer consists of a 16-bit free-running counter driven by a programmable prescaler.

It may be used for a variety of purposes, including pulse length measurement of up to two input signals (*input capture*) or generation of up to two output waveforms (*output compare* and *PWM*).

Pulse lengths and waveform periods can be modulated from a few microseconds to several milliseconds using the timer prescaler and the CPU clock prescaler.

Some ST7 devices have two on-chip 16-bit timers. They are completely independent, and do not share any resources. They are synchronized after a MCU reset as long as the timer clock frequencies are not modified.

This description covers one or two 16-bit timers. In ST7 devices with two timers, register names are prefixed with TA (Timer A) or TB (Timer B).

10.4.2 Main Features

- Programmable prescaler: f_{CPU} divided by 2, 4 or 8.
- Overflow status flag and maskable interrupt
- External clock input (must be at least 4 times slower than the CPU clock speed) with the choice of active edge
- 1 or 2 Output Compare functions each with:
 - 2 dedicated 16-bit registers
 - 2 dedicated programmable signals
 - 2 dedicated status flags
 - 1 dedicated maskable interrupt
- 1 or 2 Input Capture functions each with:
 - 2 dedicated 16-bit registers
 - 2 dedicated active edge selection signals
 - 2 dedicated status flags
 - 1 dedicated maskable interrupt
- Pulse width modulation mode (PWM)
- One pulse mode
- Reduced Power Mode
- 5 alternate functions on I/O ports (ICAP1, ICAP2, OCMP1, OCMP2, EXTCLK)*

The Block Diagram is shown in [Figure 42](#).

***Note:** Some timer pins may not be available (not bonded) in some ST7 devices. Refer to the device pin out description.

When reading an input signal on a non-bonded pin, the value will always be '1'.

10.4.3 Functional Description

10.4.3.1 Counter

The main block of the Programmable Timer is a 16-bit free running upcounter and its associated 16-bit registers. The 16-bit registers are made up of two 8-bit registers called high & low.

Counter Register (CR):

- Counter High Register (CHR) is the most significant byte (MS Byte).
- Counter Low Register (CLR) is the least significant byte (LS Byte).

Alternate Counter Register (ACR)

- Alternate Counter High Register (ACHR) is the most significant byte (MS Byte).
- Alternate Counter Low Register (ACLR) is the least significant byte (LS Byte).

These two read-only 16-bit registers contain the same value but with the difference that reading the ACLR register does not clear the TOF bit (Timer overflow flag), located in the Status register, (SR), (see note at the end of paragraph titled 16-bit read sequence).

Writing in the CLR register or ACLR register resets the free running counter to the FFFCh value. Both counters have a reset value of FFFCh (this is the only value which is reloaded in the 16-bit timer). The reset value of both counters is also FFFCh in One Pulse mode and PWM mode.

The timer clock depends on the clock control bits of the CR2 register, as illustrated in [Table 16 Clock Control Bits](#). The value in the counter register repeats every 131072, 262144 or 524288 CPU clock cycles depending on the CC[1:0] bits. The timer frequency can be $f_{CPU}/2$, $f_{CPU}/4$, $f_{CPU}/8$ or an external frequency.

16-BIT TIMER (Cont'd)

Figure 42. Timer Block Diagram

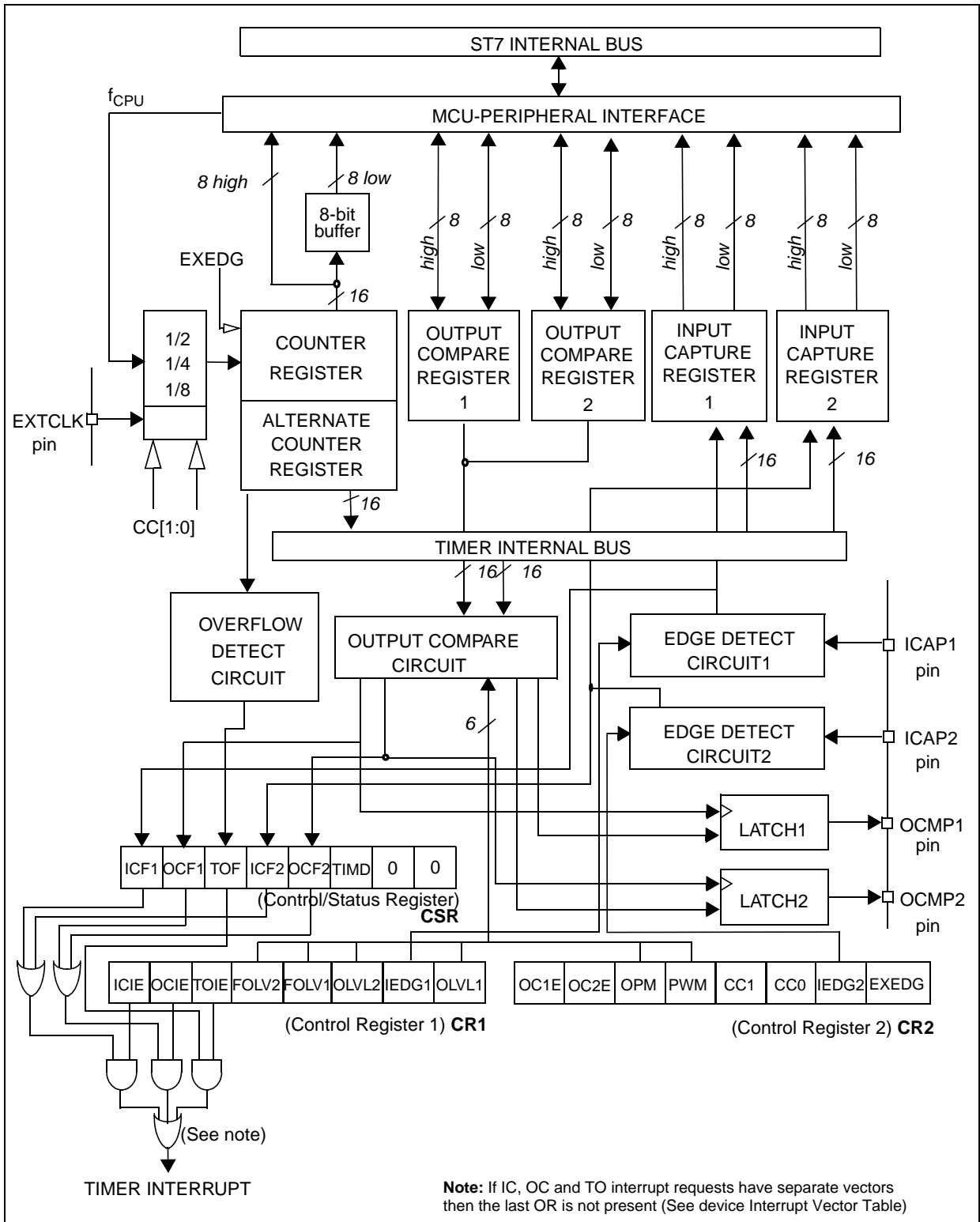

16-BIT TIMER (Cont'd)

16-bit read sequence: (from either the Counter Register or the Alternate Counter Register).

Beginning of the sequence

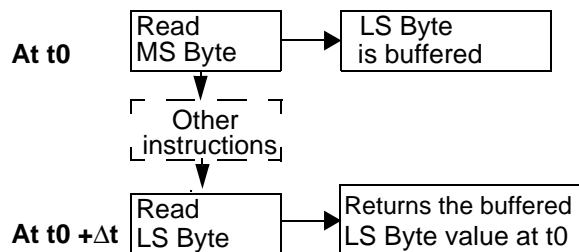

Sequence completed

The user must read the MS Byte first, then the LS Byte value is buffered automatically.

This buffered value remains unchanged until the 16-bit read sequence is completed, even if the user reads the MS Byte several times.

After a complete reading sequence, if only the CLR register or ACLR register are read, they return the LS Byte of the count value at the time of the read.

Whatever the timer mode used (input capture, output compare, one pulse mode or PWM mode) an overflow occurs when the counter rolls over from FFFFh to 0000h then:

- The TOF bit of the SR register is set.
- A timer interrupt is generated if:
 - TOIE bit of the CR1 register is set and
 - I bit of the CC register is cleared.

If one of these conditions is false, the interrupt remains pending to be issued as soon as they are both true.

Clearing the overflow interrupt request is done in two steps:

1. Reading the SR register while the TOF bit is set.
2. An access (read or write) to the CLR register.

Notes: The TOF bit is not cleared by accesses to ACLR register. The advantage of accessing the ACLR register rather than the CLR register is that it allows simultaneous use of the overflow function and reading the free running counter at random times (for example, to measure elapsed time) without the risk of clearing the TOF bit erroneously.

The timer is not affected by WAIT mode.

In HALT mode, the counter stops counting until the mode is exited. Counting then resumes from the previous count (MCU awakened by an interrupt) or from the reset count (MCU awakened by a Reset).

10.4.3.2 External Clock

The external clock (where available) is selected if CC0=1 and CC1=1 in the CR2 register.

The status of the EXEDG bit in the CR2 register determines the type of level transition on the external clock pin EXTCLK that will trigger the free running counter.

The counter is synchronized with the falling edge of the internal CPU clock.

A minimum of four falling edges of the CPU clock must occur between two consecutive active edges of the external clock; thus the external clock frequency must be less than a quarter of the CPU clock frequency.

16-BIT TIMER (Cont'd)

Figure 43. Counter Timing Diagram, internal clock divided by 2

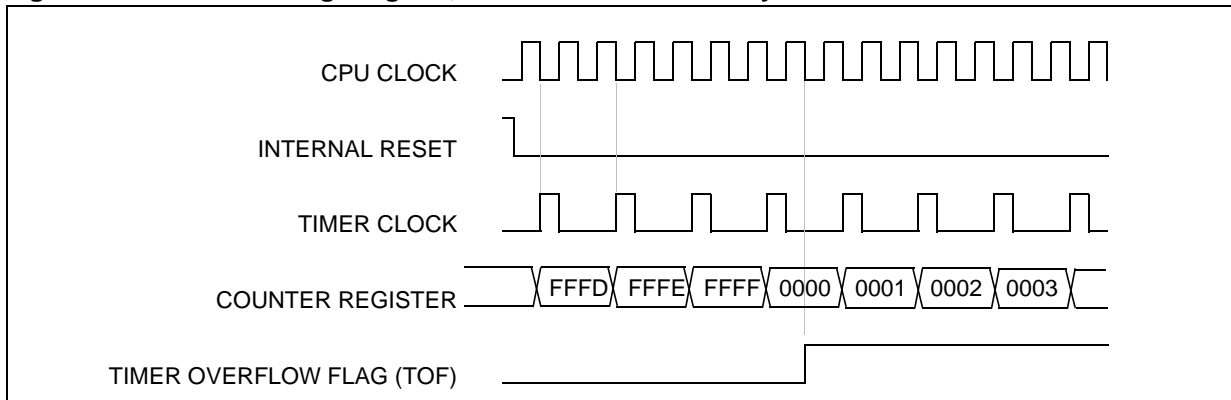

Figure 44. Counter Timing Diagram, internal clock divided by 4

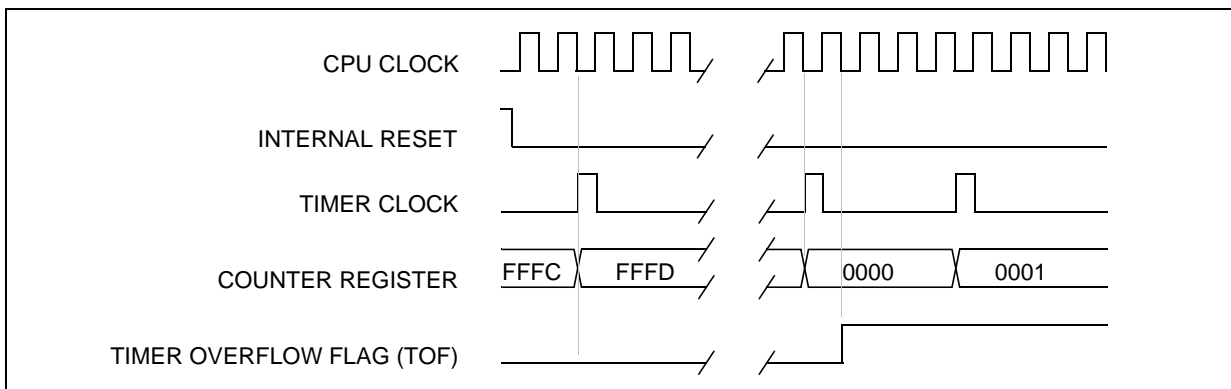
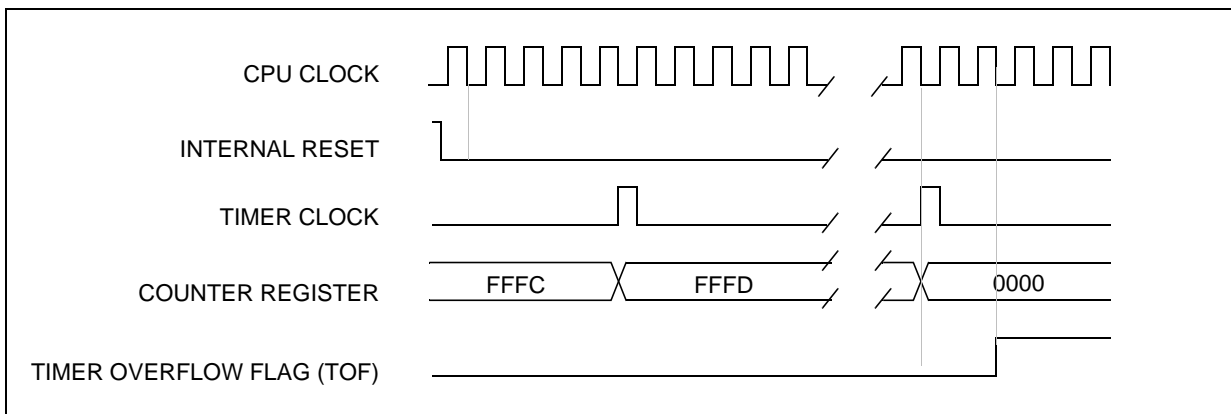

Figure 45. Counter Timing Diagram, internal clock divided by 8



Note: The MCU is in reset state when the internal reset signal is high, when it is low the MCU is running.

16-BIT TIMER (Cont'd)

10.4.3.3 Input Capture

In this section, the index, *i*, may be 1 or 2 because there are 2 input capture functions in the 16-bit timer.

The two 16-bit input capture registers (IC1R and IC2R) are used to latch the value of the free running counter after a transition is detected on the ICAP*i* pin (see figure 5).

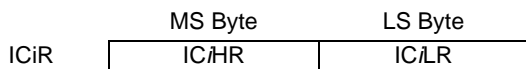

IC*i*R register is a read-only register.

The active transition is software programmable through the IEDG*i* bit of Control Registers (CR*i*).

Timing resolution is one count of the free running counter: ($f_{CPU}/CC[1:0]$).

Procedure:

To use the input capture function select the following in the CR2 register:

- Select the timer clock (CC[1:0]) (see [Table 16 Clock Control Bits](#)).
- Select the edge of the active transition on the ICAP2 pin with the IEDG2 bit (the ICAP2 pin must be configured as floating input or input with pull-up without interrupt if this configuration is available).

And select the following in the CR1 register:

- Set the ICIE bit to generate an interrupt after an input capture coming from either the ICAP1 pin or the ICAP2 pin
- Select the edge of the active transition on the ICAP1 pin with the IEDG1 bit (the ICAP1 pin must be configured as floating input or input with pull-up without interrupt if this configuration is available).

When an input capture occurs:

- ICF*i* bit is set.
- The IC*i*R register contains the value of the free running counter on the active transition on the ICAP*i* pin (see [Figure 47](#)).
- A timer interrupt is generated if the ICIE bit is set and the I bit is cleared in the CC register. Otherwise, the interrupt remains pending until both conditions become true.

Clearing the Input Capture interrupt request (i.e. clearing the ICF*i* bit) is done in two steps:

1. Reading the SR register while the ICF*i* bit is set.
2. An access (read or write) to the IC*i*LR register.

Notes:

1. After reading the IC*i*HR register, transfer of input capture data is inhibited and ICF*i* will never be set until the IC*i*LR register is also read.
2. The IC*i*R register contains the free running counter value which corresponds to the most recent input capture.
3. The 2 input capture functions can be used together even if the timer also uses the 2 output compare functions.
4. In One pulse Mode and PWM mode only Input Capture 2 can be used.
5. The alternate inputs (ICAP1 & ICAP2) are always directly connected to the timer. So any transitions on these pins activates the input capture function.
Moreover if one of the ICAP*i* pins is configured as an input and the second one as an output, an interrupt can be generated if the user toggles the output pin and if the ICIE bit is set. This can be avoided if the input capture function *i* is disabled by reading the IC*i*HR (see note 1).
6. The TOF bit can be used with interrupt generation in order to measure events that go beyond the timer range (FFFFh).

16-BIT TIMER (Cont'd)

Figure 46. Input Capture Block Diagram

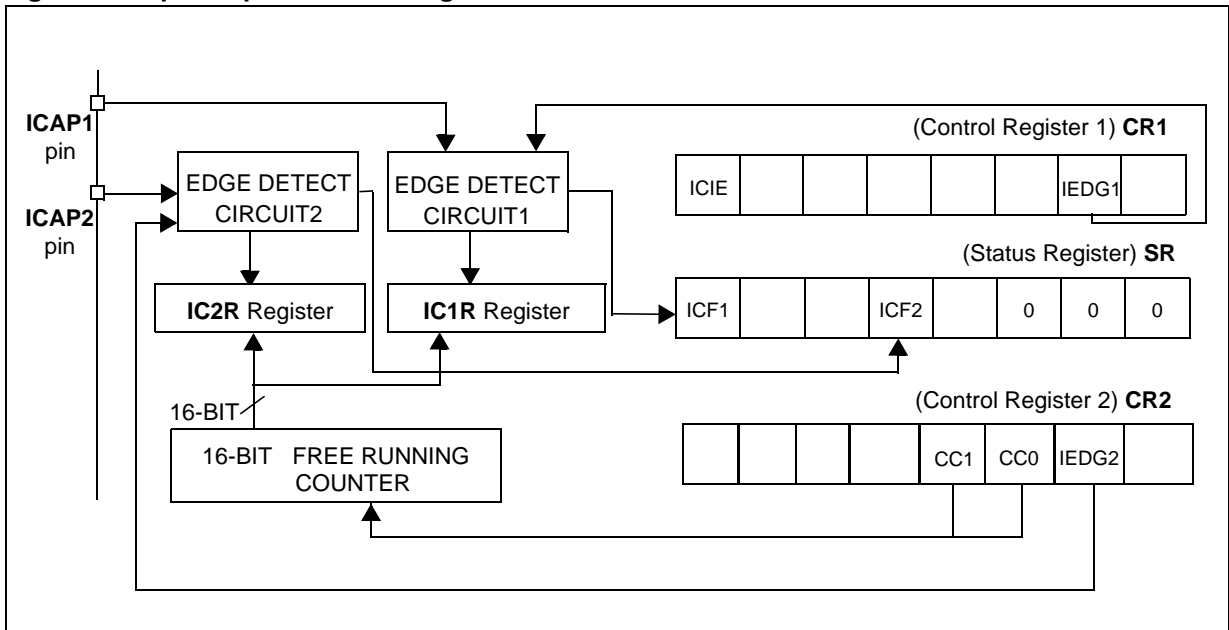
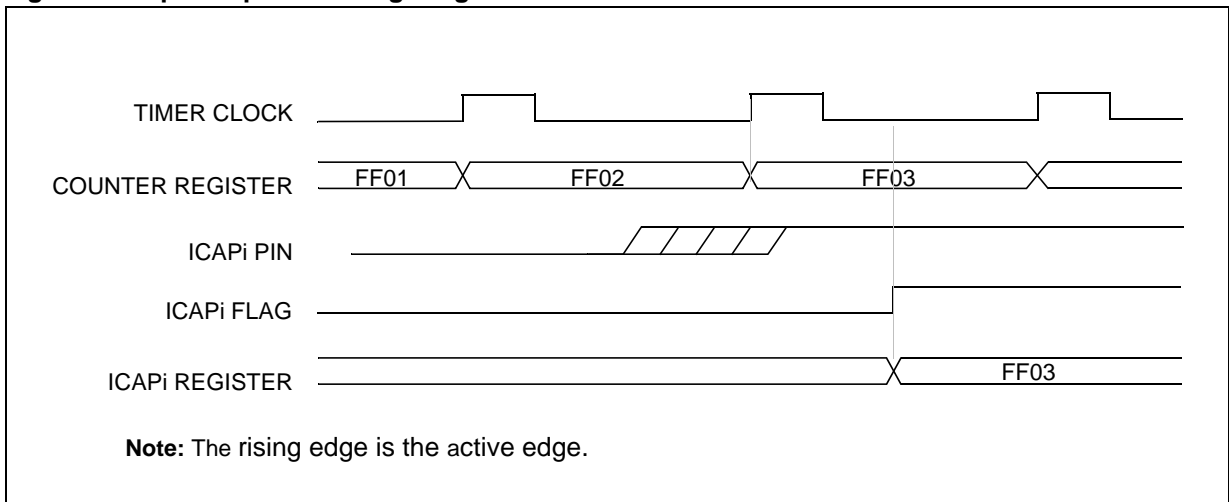

Figure 47. Input Capture Timing Diagram



16-BIT TIMER (Cont'd)

10.4.3.4 Output Compare

In this section, the index, *i*, may be 1 or 2 because there are 2 output compare functions in the 16-bit timer.

This function can be used to control an output waveform or indicate when a period of time has elapsed.

When a match is found between the Output Compare register and the free running counter, the output compare function:

- Assigns pins with a programmable value if the OC \bar{E} bit is set
- Sets a flag in the status register
- Generates an interrupt if enabled

Two 16-bit registers Output Compare Register 1 (OC1R) and Output Compare Register 2 (OC2R) contain the value to be compared to the counter register each timer clock cycle.

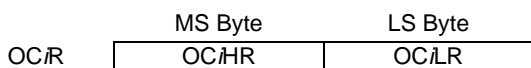

These registers are readable and writable and are not affected by the timer hardware. A reset event changes the OC*R* value to 8000h.

Timing resolution is one count of the free running counter: ($f_{CPU}/CC[1:0]$).

Procedure:

To use the output compare function, select the following in the CR2 register:

- Set the OC \bar{E} bit if an output is needed then the OCMP*i* pin is dedicated to the output compare *i* signal.
- Select the timer clock (CC[1:0]) (see [Table 16 Clock Control Bits](#)).

And select the following in the CR1 register:

- Select the OLVL*i* bit to applied to the OCMP*i* pins after the match occurs.
- Set the OCIE bit to generate an interrupt if it is needed.

When a match is found between OCR*i* register and CR register:

- OCF*i* bit is set.

- The OCMP*i* pin takes OLVL*i* bit value (OCMP*i* pin latch is forced low during reset).
- A timer interrupt is generated if the OCIE bit is set in the CR1 register and the I bit is cleared in the CC register (CC).

The OC*R* register value required for a specific timing application can be calculated using the following formula:

$$\Delta OCiR = \frac{\Delta t * f_{CPU}}{PRESC}$$

Where:

- Δt = Output compare period (in seconds)
- f_{CPU} = CPU clock frequency (in hertz)
- PRESC = Timer prescaler factor (2, 4 or 8 depending on CC[1:0] bits, see [Table 16 Clock Control Bits](#))

If the timer clock is an external clock, the formula is:

$$\Delta OCiR = \Delta t * f_{EXT}$$

Where:

- Δt = Output compare period (in seconds)
- f_{EXT} = External timer clock frequency (in hertz)

Clearing the output compare interrupt request (i.e. clearing the OCF*i* bit) is done by:

1. Reading the SR register while the OCF*i* bit is set.
2. An access (read or write) to the OC*LR* register.

The following procedure is recommended to prevent the OCF*i* bit from being set between the time it is read and the write to the OC*R* register:

- Write to the OC*HR* register (further compares are inhibited).
- Read the SR register (first step of the clearance of the OCF*i* bit, which may be already set).
- Write to the OC*LR* register (enables the output compare function and clears the OCF*i* bit).

16-BIT TIMER (Cont'd)**Notes:**

1. After a processor write cycle to the OC*i*HR register, the output compare function is inhibited until the OC*i*LR register is also written.
2. If the OC*i*E bit is not set, the OCMP*i* pin is a general I/O port and the OLV*i* bit will not appear when a match is found but an interrupt could be generated if the OCIE bit is set.
3. When the timer clock is $f_{CPU}/2$, OCF*i* and OCMP*i* are set while the counter value equals the OC*i*R register value (see [Figure 49 on page 78](#)). This behaviour is the same in OPM or PWM mode.
When the timer clock is $f_{CPU}/4$, $f_{CPU}/8$ or in external clock mode, OCF*i* and OCMP*i* are set while the counter value equals the OC*i*R register value plus 1 (see [Figure 50 on page 78](#)).
4. The output compare functions can be used both for generating external events on the OCMP*i* pins even if the input capture mode is also used.
5. The value in the 16-bit OC*i*R register and the OLV*i* bit should be changed after each successful comparison in order to control an output waveform or establish a new elapsed timeout.

Forced Compare Output capability

When the FOLV*i* bit is set by software, the OLV*i* bit is copied to the OCMP*i* pin. The OLV*i* bit has to be toggled in order to toggle the OCMP*i* pin when it is enabled (OC*i*E bit=1). The OCF*i* bit is then not set by hardware, and thus no interrupt request is generated.

The FOLV*i* bits have no effect in both one pulse mode and PWM mode.

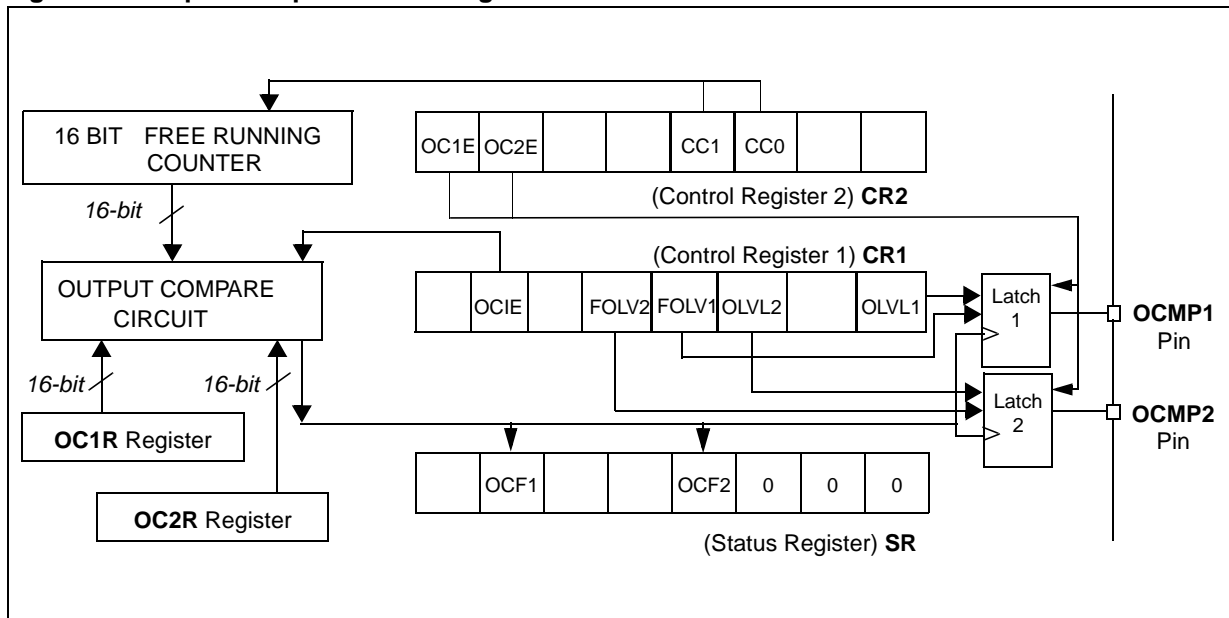
Figure 48. Output Compare Block Diagram

16-BIT TIMER (Cont'd)

Figure 49. Output Compare Timing Diagram, $f_{TIMER} = f_{CPU}/2$

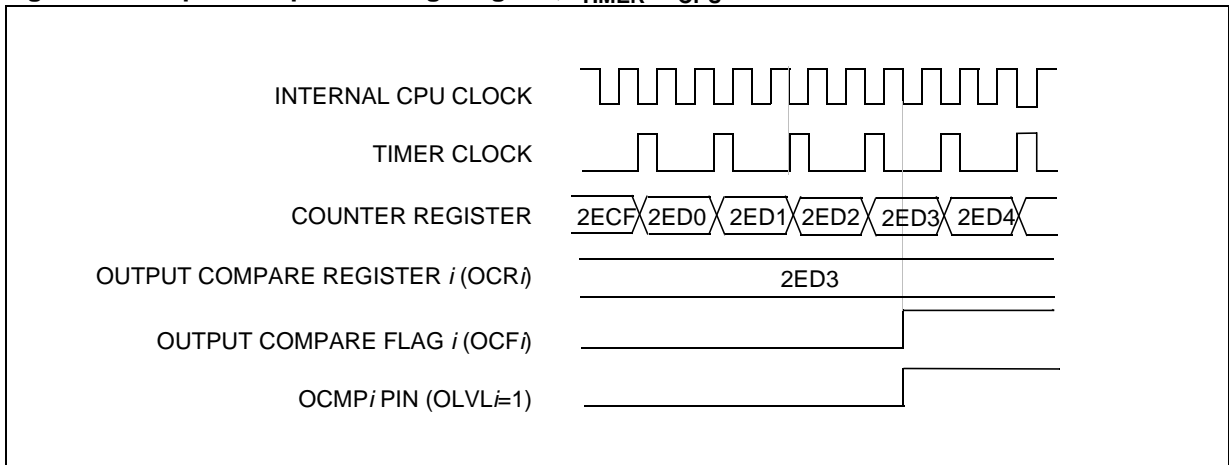
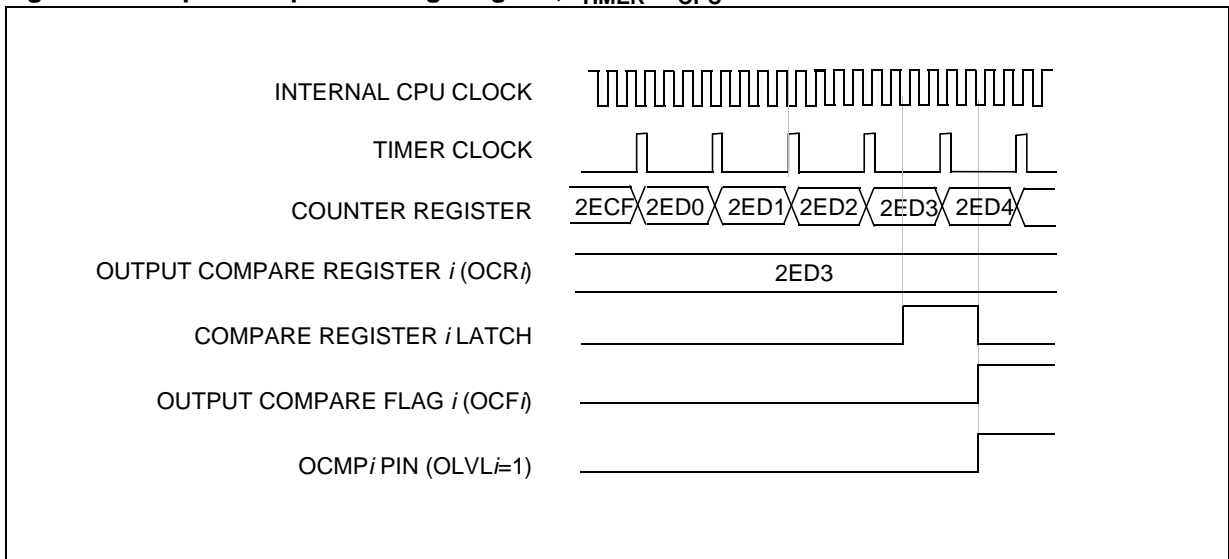

Figure 50. Output Compare Timing Diagram, $f_{TIMER} = f_{CPU}/4$



16-BIT TIMER (Cont'd)**10.4.3.5 One Pulse Mode**

One Pulse mode enables the generation of a pulse when an external event occurs. This mode is selected via the OPM bit in the CR2 register.

The one pulse mode uses the Input Capture1 function and the Output Compare1 function.

Procedure:

To use one pulse mode:

1. Load the OC1R register with the value corresponding to the length of the pulse (see the formula in the opposite column).
2. Select the following in the CR1 register:
 - Using the OLVL1 bit, select the level to be applied to the OCMP1 pin after the pulse.
 - Using the OLVL2 bit, select the level to be applied to the OCMP1 pin during the pulse.
 - Select the edge of the active transition on the ICAP1 pin with the IEDG1 bit (the ICAP1 pin must be configured as floating input).
3. Select the following in the CR2 register:
 - Set the OC1E bit, the OCMP1 pin is then dedicated to the Output Compare 1 function.
 - Set the OPM bit.
 - Select the timer clock CC[1:0] (see [Table 16 Clock Control Bits](#)).

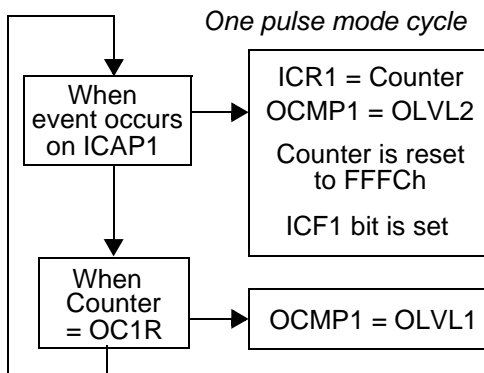

Then, on a valid event on the ICAP1 pin, the counter is initialized to FFFCh and OLVL2 bit is loaded on the OCMP1 pin, the ICF1 bit is set and the value FFFDh is loaded in the IC1R register.

Because the ICF1 bit is set when an active edge occurs, an interrupt can be generated if the ICIE bit is set.

Clearing the Input Capture interrupt request (i.e. clearing the ICF i bit) is done in two steps:

1. Reading the SR register while the ICF i bit is set.
2. An access (read or write) to the IC i LR register.

The OC1R register value required for a specific timing application can be calculated using the following formula:

$$\text{OC1R Value} = \frac{t * f_{\text{CPU}}}{\text{PRESC}} - 5$$

Where:

t = Pulse period (in seconds)

f_{CPU} = CPU clock frequency (in hertz)

PRESC = Timer prescaler factor (2, 4 or 8 depending on the CC[1:0] bits, see [Table 16 Clock Control Bits](#))

If the timer clock is an external clock the formula is:

$$\text{OC1R} = t * f_{\text{EXT}} - 5$$

Where:

t = Pulse period (in seconds)

f_{EXT} = External timer clock frequency (in hertz)

When the value of the counter is equal to the value of the contents of the OC1R register, the OLVL1 bit is output on the OCMP1 pin, (See [Figure 51](#)).

Notes:

1. The OCF1 bit cannot be set by hardware in one pulse mode but the OCF2 bit can generate an Output Compare interrupt.
2. When the Pulse Width Modulation (PWM) and One Pulse Mode (OPM) bits are both set, the PWM mode is the only active one.
3. If OLVL1=OLVL2 a continuous signal will be seen on the OCMP1 pin.
4. The ICAP1 pin can not be used to perform input capture. The ICAP2 pin can be used to perform input capture (ICF2 can be set and IC2R can be loaded) but the user must take care that the counter is reset each time a valid edge occurs on the ICAP1 pin and ICF1 can also generates interrupt if ICIE is set.
5. When one pulse mode is used OC1R is dedicated to this mode. Nevertheless OC2R and OCF2 can be used to indicate a period of time has been elapsed but cannot generate an output waveform because the level OLVL2 is dedicated to the one pulse mode.

16-BIT TIMER (Cont'd)

Figure 51. One Pulse Mode Timing Example

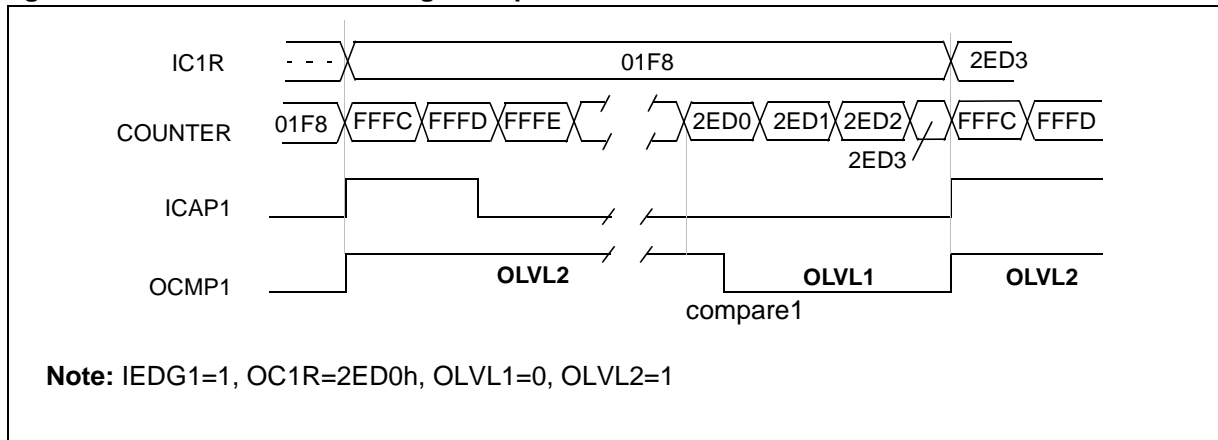
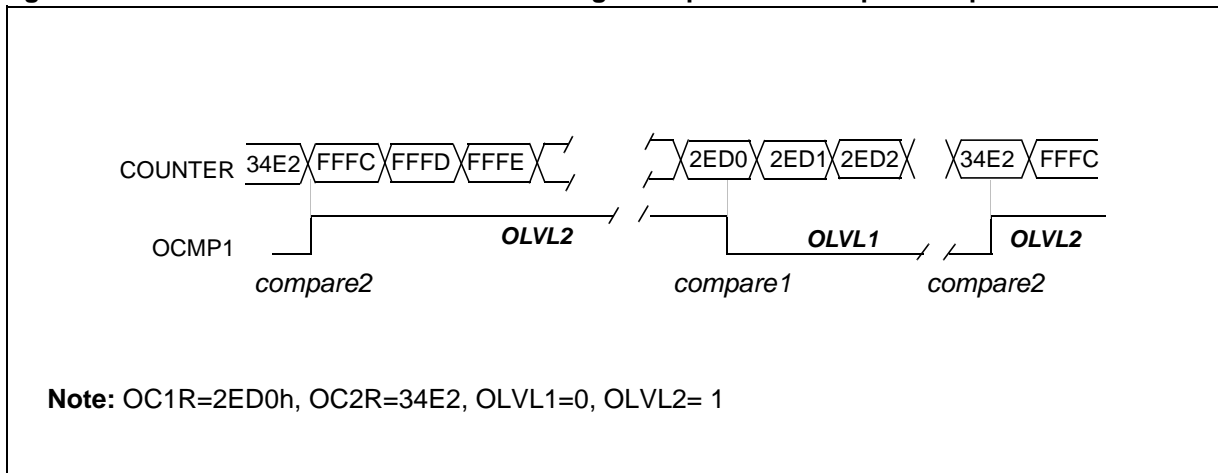

Figure 52. Pulse Width Modulation Mode Timing Example with 2 Output Compare Functions



Note: On timers with only 1 Output Compare register, a fixed frequency PWM signal can be generated using the output compare and the counter overflow to define the pulse length.

16-BIT TIMER (Cont'd)**10.4.3.6 Pulse Width Modulation Mode**

Pulse Width Modulation (PWM) mode enables the generation of a signal with a frequency and pulse length determined by the value of the OC1R and OC2R registers.

Pulse Width Modulation mode uses the complete Output Compare 1 function plus the OC2R register, and so this functionality can not be used when PWM mode is activated.

In PWM mode, double buffering is implemented on the output compare registers. Any new values written in the OC1R and OC2R registers are taken into account only at the end of the PWM period (OC2) to avoid spikes on the PWM output pin (OCMP1).

Procedure

To use pulse width modulation mode:

1. Load the OC2R register with the value corresponding to the period of the signal using the formula in the opposite column.
2. Load the OC1R register with the value corresponding to the period of the pulse if (OLVL1=0 and OLVL2=1) using the formula in the opposite column.
3. Select the following in the CR1 register:
 - Using the OLVL1 bit, select the level to be applied to the OCMP1 pin after a successful comparison with the OC1R register.
 - Using the OLVL2 bit, select the level to be applied to the OCMP1 pin after a successful comparison with the OC2R register.
4. Select the following in the CR2 register:
 - Set OC1E bit: the OCMP1 pin is then dedicated to the output compare 1 function.
 - Set the PWM bit.
 - Select the timer clock (CC[1:0]) (see [Table 16 Clock Control Bits](#)).

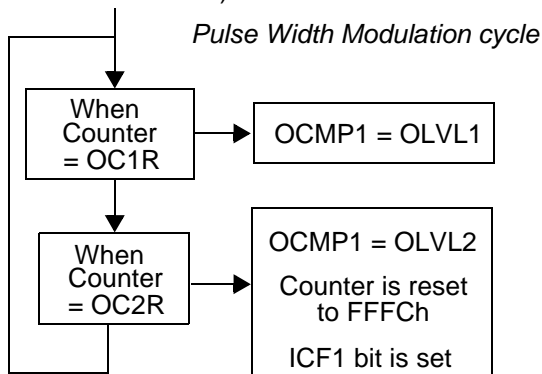

If OLVL1=1 and OLVL2=0 the length of the positive pulse is the difference between the OC2R and OC1R registers.

If OLVL1=OLVL2 a continuous signal will be seen on the OCMP1 pin.

The OC*R* register value required for a specific timing application can be calculated using the following formula:

$$\text{OC}i\text{R Value} = \frac{t * f_{\text{CPU}}}{\text{PRESC}} - 5$$

Where:

t = Signal or pulse period (in seconds)

f_{CPU} = CPU clock frequency (in hertz)

PRESC = Timer prescaler factor (2, 4 or 8 depending on CC[1:0] bits, see [Table 16 Clock Control Bits](#))

If the timer clock is an external clock the formula is:

$$\text{OC}i\text{R} = t * f_{\text{EXT}} - 5$$

Where:

t = Signal or pulse period (in seconds)

f_{EXT} = External timer clock frequency (in hertz)

The Output Compare 2 event causes the counter to be initialized to FFFCh (See [Figure 52](#))

Notes:

1. After a write instruction to the OC*HR* register, the output compare function is inhibited until the OC*LR* register is also written.
2. The OCF1 and OCF2 bits cannot be set by hardware in PWM mode therefore the Output Compare interrupt is inhibited.
3. The ICF1 bit is set by hardware when the counter reaches the OC2R value and can produce a timer interrupt if the ICIE bit is set and the I bit is cleared.
4. In PWM mode the ICAP1 pin can not be used to perform input capture because it is disconnected to the timer. The ICAP2 pin can be used to perform input capture (ICF2 can be set and IC2R can be loaded) but the user must take care that the counter is reset each period and ICF1 can also generates interrupt if ICIE is set.
5. When the Pulse Width Modulation (PWM) and One Pulse Mode (OPM) bits are both set, the PWM mode is the only active one.

16-BIT TIMER (Cont'd)

10.4.4 Low Power Modes

Mode	Description
WAIT	No effect on 16-bit Timer. Timer interrupts cause the device to exit from WAIT mode.
HALT	16-bit Timer registers are frozen. In HALT mode, the counter stops counting until Halt mode is exited. Counting resumes from the previous count when the MCU is woken up by an interrupt with “exit from HALT mode” capability or from the counter reset value when the MCU is woken up by a RESET. If an input capture event occurs on the ICAP <i>i</i> pin, the input capture detection circuitry is armed. Consequently, when the MCU is woken up by an interrupt with “exit from HALT mode” capability, the ICF <i>i</i> bit is set, and the counter value present when exiting from HALT mode is captured into the IC/R register.

10.4.5 Interrupts

Interrupt Event	Event Flag	Enable Control Bit	Exit from Wait	Exit from Halt
Input Capture 1 event/Counter reset in PWM mode	ICF1	ICIE	Yes	No
Input Capture 2 event	ICF2		Yes	No
Output Compare 1 event (not available in PWM mode)	OCF1	OCIE	Yes	No
Output Compare 2 event (not available in PWM mode)	OCF2		Yes	No
Timer Overflow event	TOF	TOIE	Yes	No

Note: The 16-bit Timer interrupt events are connected to the same interrupt vector (see Interrupts chapter). These events generate an interrupt if the corresponding Enable Control Bit is set and the interrupt mask in the CC register is reset (RIM instruction).

10.4.6 Summary of Timer modes

MODES	TIMER RESOURCES			
	Input Capture 1	Input Capture 2	Output Compare 1	Output Compare 2
Input Capture (1 and/or 2)	Yes	Yes	Yes	Yes
Output Compare (1 and/or 2)	Yes	Yes	Yes	Yes
One Pulse Mode	No	Not Recommended ¹⁾	No	Partially ²⁾
PWM Mode	No	Not Recommended ³⁾	No	No

1) See note 4 in [Section 10.4.3.5 One Pulse Mode](#)

2) See note 5 in [Section 10.4.3.5 One Pulse Mode](#)

3) See note 4 in [Section 10.4.3.6 Pulse Width Modulation Mode](#)

16-BIT TIMER (Cont'd)**10.4.7 Register Description**

Each Timer is associated with three control and status registers, and with six pairs of data registers (16-bit values) relating to the two input captures, the two output compares, the counter and the alternate counter.

CONTROL REGISTER 1 (CR1)

Read/Write

Reset Value: 0000 0000 (00h)

7							0
ICIE	OCIE	TOIE	FOLV2	FOLV1	OLVL2	IEDG1	OLVL1

Bit 7 = **ICIE** *Input Capture Interrupt Enable*.

0: Interrupt is inhibited.

1: A timer interrupt is generated whenever the ICF1 or ICF2 bit of the SR register is set.

Bit 6 = **OCIE** *Output Compare Interrupt Enable*.

0: Interrupt is inhibited.

1: A timer interrupt is generated whenever the OCF1 or OCF2 bit of the SR register is set.

Bit 5 = **TOIE** *Timer Overflow Interrupt Enable*.

0: Interrupt is inhibited.

1: A timer interrupt is enabled whenever the TOF bit of the SR register is set.

Bit 4 = **FOLV2** *Forced Output Compare 2*.

This bit is set and cleared by software.

0: No effect on the OCMP2 pin.

1: Forces the OLVL2 bit to be copied to the OCMP2 pin, if the OC2E bit is set and even if there is no successful comparison.

Bit 3 = **FOLV1** *Forced Output Compare 1*.

This bit is set and cleared by software.

0: No effect on the OCMP1 pin.

1: Forces OLVL1 to be copied to the OCMP1 pin, if the OC1E bit is set and even if there is no successful comparison.

Bit 2 = **OLVL2** *Output Level 2*.

This bit is copied to the OCMP2 pin whenever a successful comparison occurs with the OC2R register and OCxE is set in the CR2 register. This value is copied to the OCMP1 pin in One Pulse Mode and Pulse Width Modulation mode.

Bit 1 = **IEDG1** *Input Edge 1*.

This bit determines which type of level transition on the ICAP1 pin will trigger the capture.

0: A falling edge triggers the capture.

1: A rising edge triggers the capture.

Bit 0 = **OLVL1** *Output Level 1*.

The OLVL1 bit is copied to the OCMP1 pin whenever a successful comparison occurs with the OC1R register and the OC1E bit is set in the CR2 register.

16-BIT TIMER (Cont'd)

CONTROL REGISTER 2 (CR2)

Read/Write

Reset Value: 0000 0000 (00h)

7							0
OC1E	OC2E	OPM	PWM	CC1	CC0	IEDG2	EXEDG

Bit 7 = **OC1E** *Output Compare 1 Pin Enable*.
 This bit is used only to output the signal from the timer on the OCMP1 pin (OLV1 in Output Compare mode, both OLV1 and OLV2 in PWM and one-pulse mode). Whatever the value of the OC1E bit, the Output Compare 1 function of the timer remains active.

0: OCMP1 pin alternate function disabled (I/O pin free for general-purpose I/O).
 1: OCMP1 pin alternate function enabled.

Bit 6 = **OC2E** *Output Compare 2 Pin Enable*.
 This bit is used only to output the signal from the timer on the OCMP2 pin (OLV2 in Output Compare mode). Whatever the value of the OC2E bit, the Output Compare 2 function of the timer remains active.

0: OCMP2 pin alternate function disabled (I/O pin free for general-purpose I/O).
 1: OCMP2 pin alternate function enabled.

Bit 5 = **OPM** *One Pulse Mode*.
 0: One Pulse Mode is not active.
 1: One Pulse Mode is active, the ICAP1 pin can be used to trigger one pulse on the OCMP1 pin; the active transition is given by the IEDG1 bit. The length of the generated pulse depends on the contents of the OC1R register.

Bit 4 = **PWM** *Pulse Width Modulation*.
 0: PWM mode is not active.
 1: PWM mode is active, the OCMP1 pin outputs a programmable cyclic signal; the length of the pulse depends on the value of OC1R register; the period depends on the value of OC2R register.

Bit 3, 2 = **CC[1:0]** *Clock Control*.
 The timer clock mode depends on these bits:

Table 16. Clock Control Bits

Timer Clock	CC1	CC0
$f_{CPU} / 4$	0	0
$f_{CPU} / 2$	0	1
$f_{CPU} / 8$	1	0
External Clock (where available)	1	1

Note: If the external clock pin is not available, programming the external clock configuration stops the counter.

Bit 1 = **IEDG2** *Input Edge 2*.
 This bit determines which type of level transition on the ICAP2 pin will trigger the capture.
 0: A falling edge triggers the capture.
 1: A rising edge triggers the capture.

Bit 0 = **EXEDG** *External Clock Edge*.
 This bit determines which type of level transition on the external clock pin EXTCLK will trigger the counter register.
 0: A falling edge triggers the counter register.
 1: A rising edge triggers the counter register.

16-BIT TIMER (Cont'd)**CONTROL/STATUS REGISTER (CSR)**

Read/Write (bits 7:3 read only)

Reset Value: xxxx x0xx (xxh)

7							0
ICF1	OCF1	TOF	ICF2	OCF2	TIMD	0	0

Bit 7 = ICF1 Input Capture Flag 1.

0: No input capture (reset value).

1: An input capture has occurred on the ICAP1 pin or the counter has reached the OC2R value in PWM mode. To clear this bit, first read the SR register, then read or write the low byte of the IC1R (IC1LR) register.

Bit 6 = OCF1 Output Compare Flag 1.

0: No match (reset value).

1: The content of the free running counter has matched the content of the OC1R register. To clear this bit, first read the SR register, then read or write the low byte of the OC1R (OC1LR) register.

Bit 5 = TOF Timer Overflow Flag.

0: No timer overflow (reset value).

1: The free running counter rolled over from FFFFh to 0000h. To clear this bit, first read the SR register, then read or write the low byte of the CR (CLR) register.

Note: Reading or writing the ACLR register does not clear TOF.**Bit 4 = ICF2 Input Capture Flag 2.**

0: No input capture (reset value).

1: An input capture has occurred on the ICAP2 pin. To clear this bit, first read the SR register, then read or write the low byte of the IC2R (IC2LR) register.

Bit 3 = OCF2 Output Compare Flag 2.

0: No match (reset value).

1: The content of the free running counter has matched the content of the OC2R register. To clear this bit, first read the SR register, then read or write the low byte of the OC2R (OC2LR) register.

Bit 2 = TIMD Timer disable.

This bit is set and cleared by software. When set, it freezes the timer prescaler and counter and disabled the output functions (OCMP1 and OCMP2 pins) to reduce power consumption. Access to the timer registers is still available, allowing the timer configuration to be changed, or the counter reset, while it is disabled.

0: Timer enabled

1: Timer prescaler, counter and outputs disabled

Bits 1:0 = Reserved, must be kept cleared.

16-BIT TIMER (Cont'd)

INPUT CAPTURE 1 HIGH REGISTER (IC1HR)

Read Only
 Reset Value: Undefined

This is an 8-bit read only register that contains the high part of the counter value (transferred by the input capture 1 event).

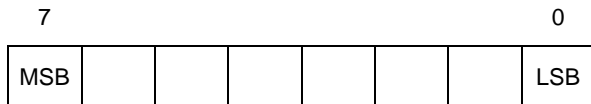

OUTPUT COMPARE 1 HIGH REGISTER (OC1HR)

Read/Write
 Reset Value: 1000 0000 (80h)

This is an 8-bit register that contains the high part of the value to be compared to the CHR register.

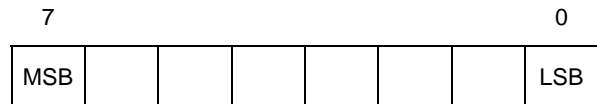

INPUT CAPTURE 1 LOW REGISTER (IC1LR)

Read Only
 Reset Value: Undefined

This is an 8-bit read only register that contains the low part of the counter value (transferred by the input capture 1 event).



OUTPUT COMPARE 1 LOW REGISTER (OC1LR)

Read/Write
 Reset Value: 0000 0000 (00h)

This is an 8-bit register that contains the low part of the value to be compared to the CLR register.



16-BIT TIMER (Cont'd)

OUTPUT COMPARE 2 HIGH REGISTER (OC2HR)

Read/Write
Reset Value: 1000 0000 (80h)

This is an 8-bit register that contains the high part of the value to be compared to the CHR register.

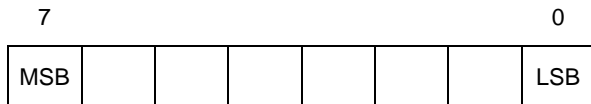

OUTPUT COMPARE 2 LOW REGISTER (OC2LR)

Read/Write
Reset Value: 0000 0000 (00h)

This is an 8-bit register that contains the low part of the value to be compared to the CLR register.



COUNTER HIGH REGISTER (CHR)

Read Only
Reset Value: 1111 1111 (FFh)

This is an 8-bit register that contains the high part of the counter value.



COUNTER LOW REGISTER (CLR)

Read Only
Reset Value: 1111 1100 (FCh)

This is an 8-bit register that contains the low part of the counter value. A write to this register resets the counter. An access to this register after accessing the CSR register clears the TOF bit.



ALTERNATE COUNTER HIGH REGISTER (ACHR)

Read Only
Reset Value: 1111 1111 (FFh)

This is an 8-bit register that contains the high part of the counter value.

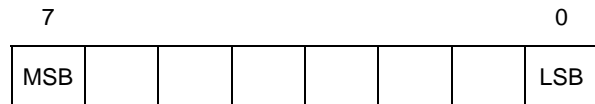

ALTERNATE COUNTER LOW REGISTER (ACLR)

Read Only
Reset Value: 1111 1100 (FCh)

This is an 8-bit register that contains the low part of the counter value. A write to this register resets the counter. An access to this register after an access to CSR register does not clear the TOF bit in the CSR register.

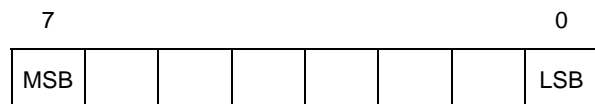

INPUT CAPTURE 2 HIGH REGISTER (IC2HR)

Read Only
Reset Value: Undefined

This is an 8-bit read only register that contains the high part of the counter value (transferred by the Input Capture 2 event).

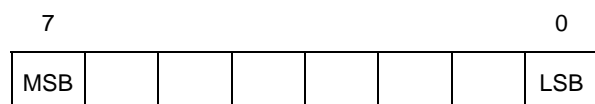

INPUT CAPTURE 2 LOW REGISTER (IC2LR)

Read Only
Reset Value: Undefined

This is an 8-bit read only register that contains the low part of the counter value (transferred by the Input Capture 2 event).



16-BIT TIMER (Cont'd)

Table 17. 16-Bit Timer Register Map and Reset Values

Address (Hex.)	Register Label	7	6	5	4	3	2	1	0
Timer A: 32 Timer B: 42	CR1 Reset Value	ICIE 0	OCIE 0	TOIE 0	FOLV2 0	FOLV1 0	OLVL2 0	IEDG1 0	OLVL1 0
Timer A: 31 Timer B: 41	CR2 Reset Value	OC1E 0	OC2E 0	OPM 0	PWM 0	CC1 0	CC0 0	IEDG2 0	EXEDG 0
Timer A: 33 Timer B: 43	CSR Reset Value	ICF1 x	OCF1 x	TOF x	ICF2 x	OCF2 x	TIMD 0	- x	- x
Timer A: 34 Timer B: 44	IC1HR Reset Value	MSB x	x	x	x	x	x	x	LSB x
Timer A: 35 Timer B: 45	IC1LR Reset Value	MSB x	x	x	x	x	x	x	LSB x
Timer A: 36 Timer B: 46	OC1HR Reset Value	MSB 1	0	0	0	0	0	0	LSB 0
Timer A: 37 Timer B: 47	OC1LR Reset Value	MSB 0	0	0	0	0	0	0	LSB 0
Timer A: 3E Timer B: 4E	OC2HR Reset Value	MSB 1	0	0	0	0	0	0	LSB 0
Timer A: 3F Timer B: 4F	OC2LR Reset Value	MSB 0	0	0	0	0	0	0	LSB 0
Timer A: 38 Timer B: 48	CHR Reset Value	MSB 1	1	1	1	1	1	1	LSB 1
Timer A: 39 Timer B: 49	CLR Reset Value	MSB 1	1	1	1	1	1	0	LSB 0
Timer A: 3A Timer B: 4A	ACHR Reset Value	MSB 1	1	1	1	1	1	1	LSB 1
Timer A: 3B Timer B: 4B	ACLR Reset Value	MSB 1	1	1	1	1	1	0	LSB 0
Timer A: 3C Timer B: 4C	IC2HR Reset Value	MSB x	x	x	x	x	x	x	LSB x
Timer A: 3D Timer B: 4D	IC2LR Reset Value	MSB x	x	x	x	x	x	x	LSB x

Related Documentation

- AN 973: SCI software communications using 16-bit timer
- AN 974: Real Time Clock with ST7 Timer Output Compare
- AN 976: Driving a buzzer through the ST7 Timer PWM function

- AN1041: Using ST7 PWM signal to generate analog input (sinusoid)
- AN1046: UART emulation software
- AN1078: PWM duty cycle switch implementing true 0 or 100 per cent duty cycle
- AN1504: Starting a PWM signal directly at high level using the ST7 16-Bit timer

10.5 SERIAL PERIPHERAL INTERFACE (SPI)

10.5.1 Introduction

The Serial Peripheral Interface (SPI) allows full-duplex, synchronous, serial communication with external devices. An SPI system may consist of a master and one or more slaves however the SPI interface can not be a master in a multi-master system.

10.5.2 Main Features

- Full duplex synchronous transfers (on 3 lines)
- Simplex synchronous transfers (on 2 lines)
- Master or slave operation
- Six master mode frequencies ($f_{CPU}/4$ max.)
- $f_{CPU}/2$ max. slave mode frequency (see note)
- \overline{SS} Management by software or hardware
- Programmable clock polarity and phase
- End of transfer interrupt flag
- Write collision, Master Mode Fault and Overrun flags

Note: In slave mode, continuous transmission is not possible at maximum frequency due to the software overhead for clearing status flags and to initiate the next transmission sequence.

10.5.3 General Description

Figure 53 shows the serial peripheral interface (SPI) block diagram. There are 3 registers:

- SPI Control Register (SPICR)
- SPI Control/Status Register (SPICSR)
- SPI Data Register (SPIDR)

The SPI is connected to external devices through 4 pins:

- MISO: Master In / Slave Out data
- MOSI: Master Out / Slave In data
- SCK: Serial Clock out by SPI masters and input by SPI slaves

Figure 53. Serial Peripheral Interface Block Diagram

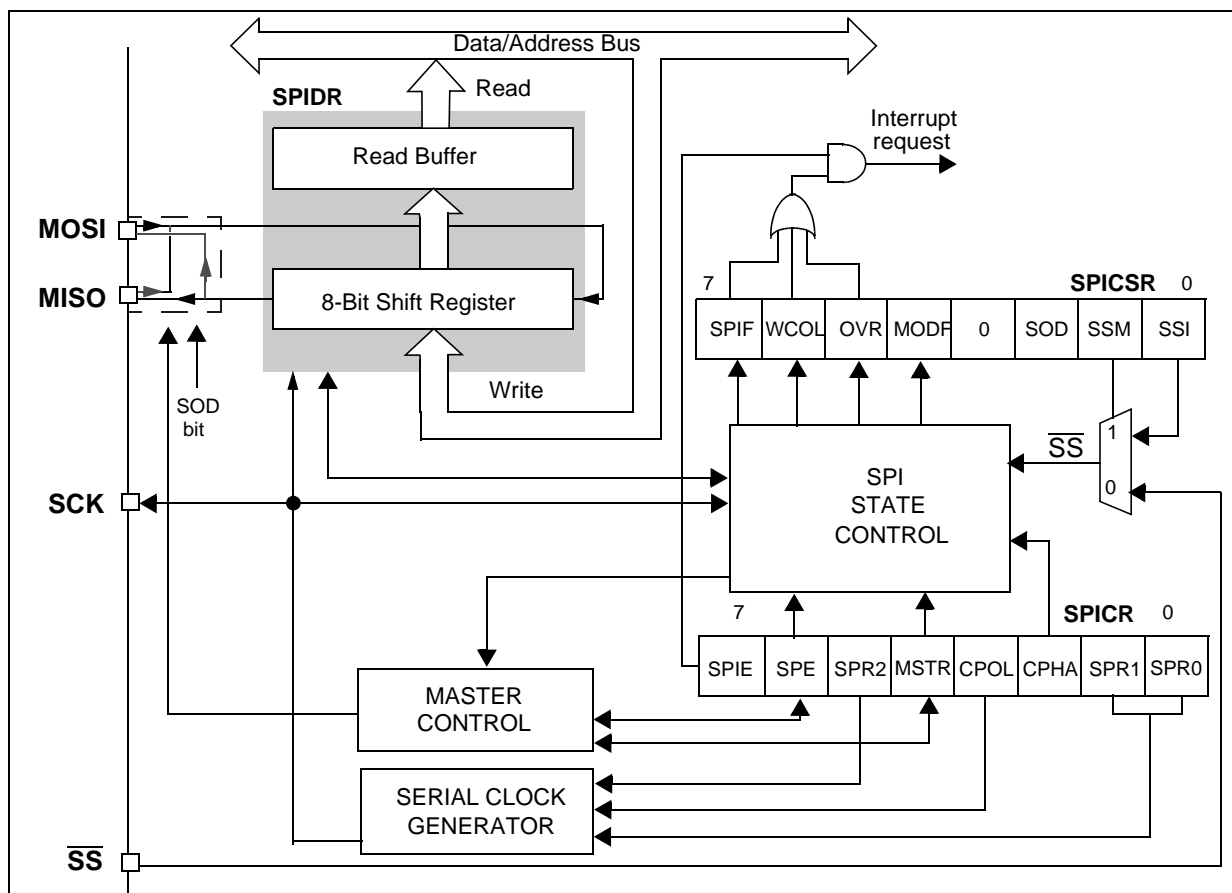

SERIAL PERIPHERAL INTERFACE (Cont'd)

- \overline{SS} : Slave select:
This input signal acts as a 'chip select' to let the SPI master communicate with slaves individually and to avoid contention on the data lines. Slave \overline{SS} inputs can be driven by standard I/O ports on the master MCU.

10.5.3.1 Functional Description

A basic example of interconnections between a single master and a single slave is illustrated in Figure 54.

The MOSI pins are connected together and the MISO pins are connected together. In this way data is transferred serially between master and slave (most significant bit first).

The communication is always initiated by the master. When the master device transmits data to a slave device via MOSI pin, the slave device responds by sending data to the master device via the MISO pin. This implies full duplex communication with both data out and data in synchronized with the same clock signal (which is provided by the master device via the SCK pin).

To use a single data line, the MISO and MOSI pins must be connected at each node (in this case only simplex communication is possible).

Four possible data/clock timing relationships may be chosen (see Figure 57) but master and slave must be programmed with the same timing mode.

Figure 54. Single Master/ Single Slave Application

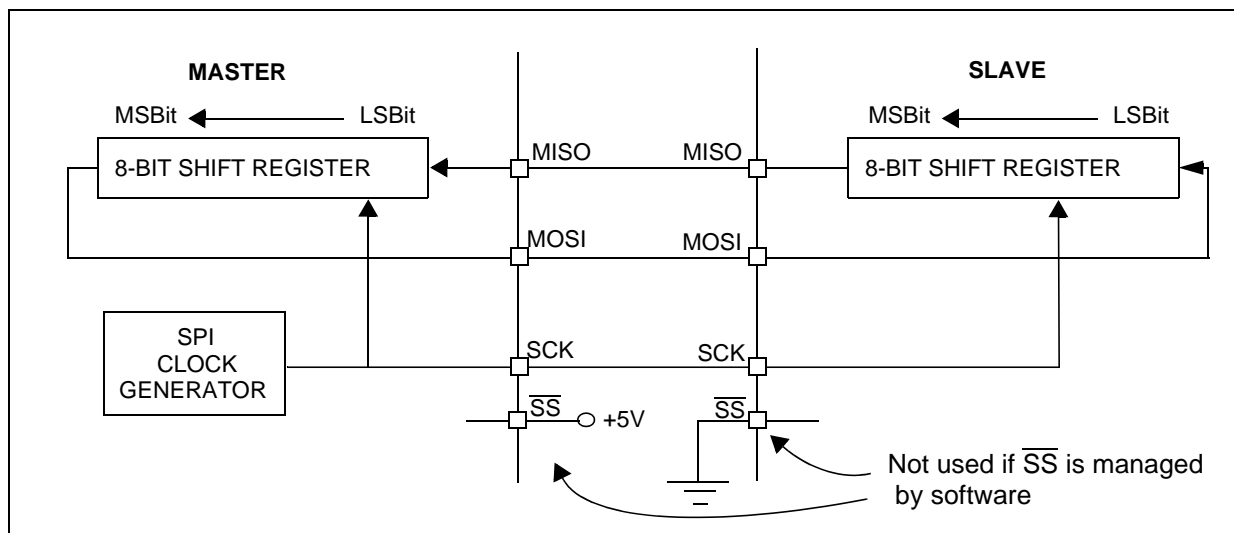

SERIAL PERIPHERAL INTERFACE (Cont'd)

10.5.3.2 Slave Select Management

As an alternative to using the \overline{SS} pin to control the Slave Select signal, the application can choose to manage the Slave Select signal by software. This is configured by the SSM bit in the SPICSR register (see Figure 56)

In software management, the external \overline{SS} pin is free for other application uses and the internal \overline{SS} signal level is driven by writing to the SSI bit in the SPICSR register.

In Master mode:

- \overline{SS} internal must be held high continuously

In Slave Mode:

There are two cases depending on the data/clock timing relationship (see Figure 55):

If CPHA=1 (data latched on 2nd clock edge):

- \overline{SS} internal must be held low during the entire transmission. This implies that in single slave applications the \overline{SS} pin either can be tied to V_{SS} , or made free for standard I/O by managing the \overline{SS} function by software (SSM= 1 and SSI=0 in the in the SPICSR register)

If CPHA=0 (data latched on 1st clock edge):

- \overline{SS} internal must be held low during byte transmission and pulled high between each byte to allow the slave to write to the shift register. If \overline{SS} is not pulled high, a Write Collision error will occur when the slave writes to the shift register (see Section 10.5.5.3).

Figure 55. Generic \overline{SS} Timing Diagram

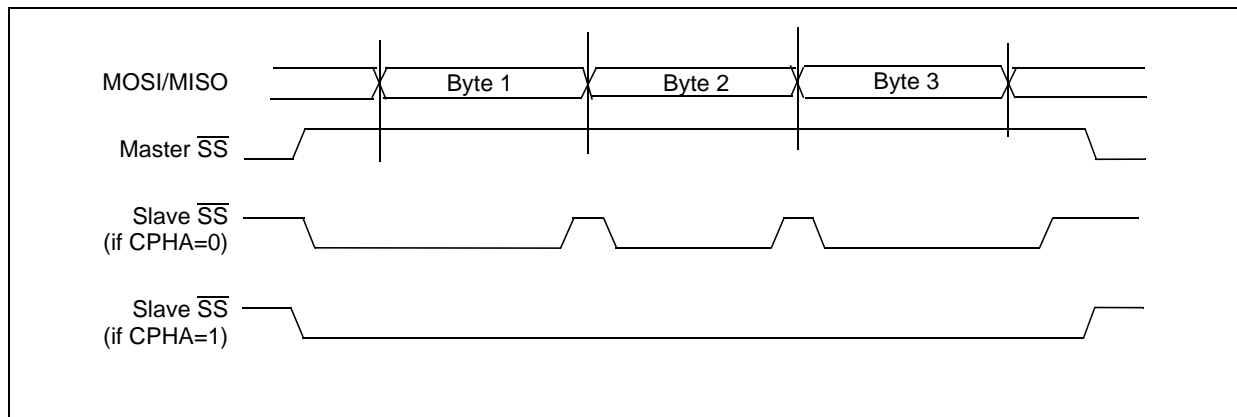
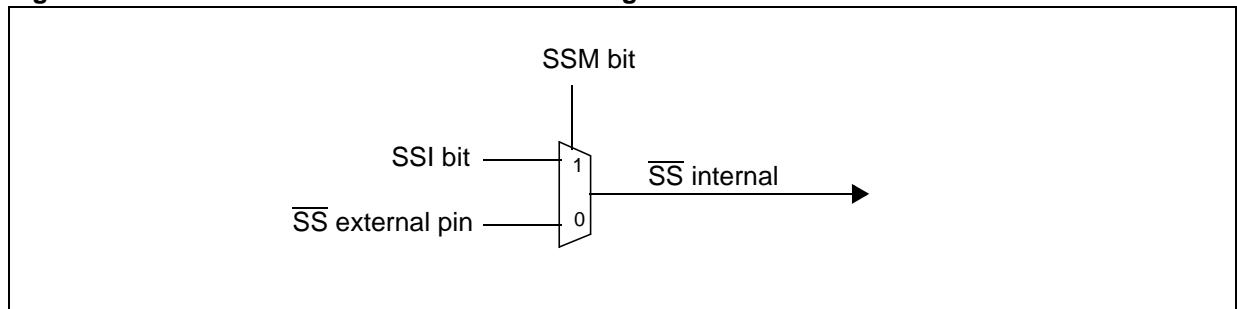

Figure 56. Hardware/Software Slave Select Management



SERIAL PERIPHERAL INTERFACE (Cont'd)

10.5.3.3 Master Mode Operation

In master mode, the serial clock is output on the SCK pin. The clock frequency, polarity and phase are configured by software (refer to the description of the SPICSR register).

Note: The idle state of SCK must correspond to the polarity selected in the SPICSR register (by pulling up SCK if CPOL=1 or pulling down SCK if CPOL=0).

To operate the SPI in master mode, perform the following steps in order (if the SPICSR register is not written first, the SPICR register setting (MSTR bit) may be not taken into account):

- Write to the SPICR register:
 - Select the clock frequency by configuring the SPR[2:0] bits.
 - Select the clock polarity and clock phase by configuring the CPOL and CPHA bits. [Figure 57](#) shows the four possible configurations.

Note: The slave must have the same CPOL and CPHA settings as the master.
- Write to the SPICSR register:
 - Either set the SSM bit and set the SSI bit or clear the SSM bit and tie the SS pin high for the complete byte transmit sequence.
- Write to the SPICR register:
 - Set the MSTR and SPE bits.

Note: MSTR and SPE bits remain set only if SS is high).

The transmit sequence begins when software writes a byte in the SPIDR register.

10.5.3.4 Master Mode Transmit Sequence

When software writes to the SPIDR register, the data byte is loaded into the 8-bit shift register and then shifted out serially to the MOSI pin most significant bit first.

When data transfer is complete:

- The SPIF bit is set by hardware
- An interrupt request is generated if the SPIE bit is set and the interrupt mask in the CCR register is cleared.

Clearing the SPIF bit is performed by the following software sequence:

- An access to the SPICSR register while the SPIF bit is set
- A read to the SPIDR register.

Note: While the SPIF bit is set, all writes to the SPIDR register are inhibited until the SPICSR register is read.

10.5.3.5 Slave Mode Operation

In slave mode, the serial clock is received on the SCK pin from the master device.

To operate the SPI in slave mode:

- Write to the SPICSR register to perform the following actions:
 - Select the clock polarity and clock phase by configuring the CPOL and CPHA bits (see [Figure 57](#)).

Note: The slave must have the same CPOL and CPHA settings as the master.
 - Manage the \overline{SS} pin as described in [Section 10.5.3.2](#) and [Figure 55](#). If CPHA=1 \overline{SS} must be held low continuously. If CPHA=0 \overline{SS} must be held low during byte transmission and pulled up between each byte to let the slave write in the shift register.
- Write to the SPICR register to clear the MSTR bit and set the SPE bit to enable the SPI I/O functions.

10.5.3.6 Slave Mode Transmit Sequence

When software writes to the SPIDR register, the data byte is loaded into the 8-bit shift register and then shifted out serially to the MISO pin most significant bit first.

The transmit sequence begins when the slave device receives the clock signal and the most significant bit of the data on its MOSI pin.

When data transfer is complete:

- The SPIF bit is set by hardware
- An interrupt request is generated if SPIE bit is set and interrupt mask in the CCR register is cleared.

Clearing the SPIF bit is performed by the following software sequence:

- An access to the SPICSR register while the SPIF bit is set.
- A write or a read to the SPIDR register.

Notes: While the SPIF bit is set, all writes to the SPIDR register are inhibited until the SPICSR register is read.

The SPIF bit can be cleared during a second transmission; however, it must be cleared before the second SPIF bit in order to prevent an Overrun condition (see [Section 10.5.5.2](#)).

SERIAL PERIPHERAL INTERFACE (Cont'd)

10.5.4 Clock Phase and Clock Polarity

Four possible timing relationships may be chosen by software, using the CPOL and CPHA bits (See Figure 57).

Note: The idle state of SCK must correspond to the polarity selected in the SPICSR register (by pulling up SCK if CPOL=1 or pulling down SCK if CPOL=0).

The combination of the CPOL clock polarity and CPHA (clock phase) bits selects the data capture clock edge

Figure 57, shows an SPI transfer with the four combinations of the CPHA and CPOL bits. The diagram may be interpreted as a master or slave timing diagram where the SCK pin, the MISO pin, the MOSI pin are directly connected between the master and the slave device.

Note: If CPOL is changed at the communication byte boundaries, the SPI must be disabled by re-setting the SPE bit.

Figure 57. Data Clock Timing Diagram

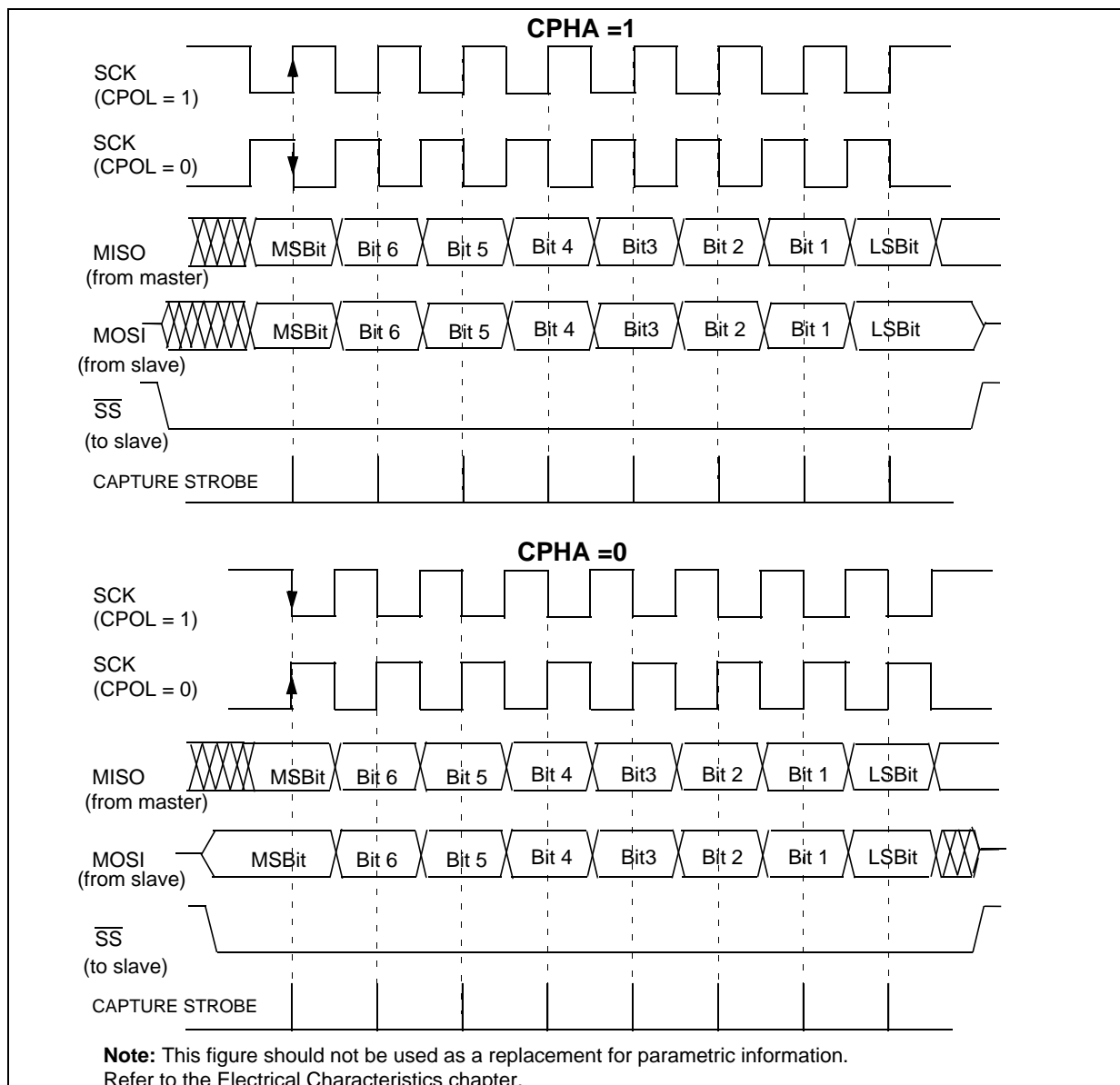

SERIAL PERIPHERAL INTERFACE (Cont'd)

10.5.5 Error Flags

10.5.5.1 Master Mode Fault (MODF)

Master mode fault occurs when the master device has its \overline{SS} pin pulled low.

When a Master mode fault occurs:

- The MODF bit is set and an SPI interrupt request is generated if the SPIE bit is set.
- The SPE bit is reset. This blocks all output from the device and disables the SPI peripheral.
- The MSTR bit is reset, thus forcing the device into slave mode.

Clearing the MODF bit is done through a software sequence:

1. A read access to the SPICSR register while the MODF bit is set.
2. A write to the SPICR register.

Notes: To avoid any conflicts in an application with multiple slaves, the \overline{SS} pin must be pulled high during the MODF bit clearing sequence. The SPE and MSTR bits may be restored to their original state during or after this clearing sequence.

Hardware does not allow the user to set the SPE and MSTR bits while the MODF bit is set except in the MODF bit clearing sequence.

10.5.5.2 Overrun Condition (OVR)

An overrun condition occurs, when the master device has sent a data byte and the slave device has

not cleared the SPIF bit issued from the previously transmitted byte.

When an Overrun occurs:

- The OVR bit is set and an interrupt request is generated if the SPIE bit is set.

In this case, the receiver buffer contains the byte sent after the SPIF bit was last cleared. A read to the SPIDR register returns this byte. All other bytes are lost.

The OVR bit is cleared by reading the SPICSR register.

10.5.5.3 Write Collision Error (WCOL)

A write collision occurs when the software tries to write to the SPIDR register while a data transfer is taking place with an external device. When this happens, the transfer continues uninterrupted; and the software write will be unsuccessful.

Write collisions can occur both in master and slave mode. See also [Section 10.5.3.2 Slave Select Management](#).

Note: a "read collision" will never occur since the received data byte is placed in a buffer in which access is always synchronous with the MCU operation.

The WCOL bit in the SPICSR register is set if a write collision occurs.

No SPI interrupt is generated when the WCOL bit is set (the WCOL bit is a status flag only).

Clearing the WCOL bit is done through a software sequence (see [Figure 58](#)).

Figure 58. Clearing the WCOL bit (Write Collision Flag) Software Sequence

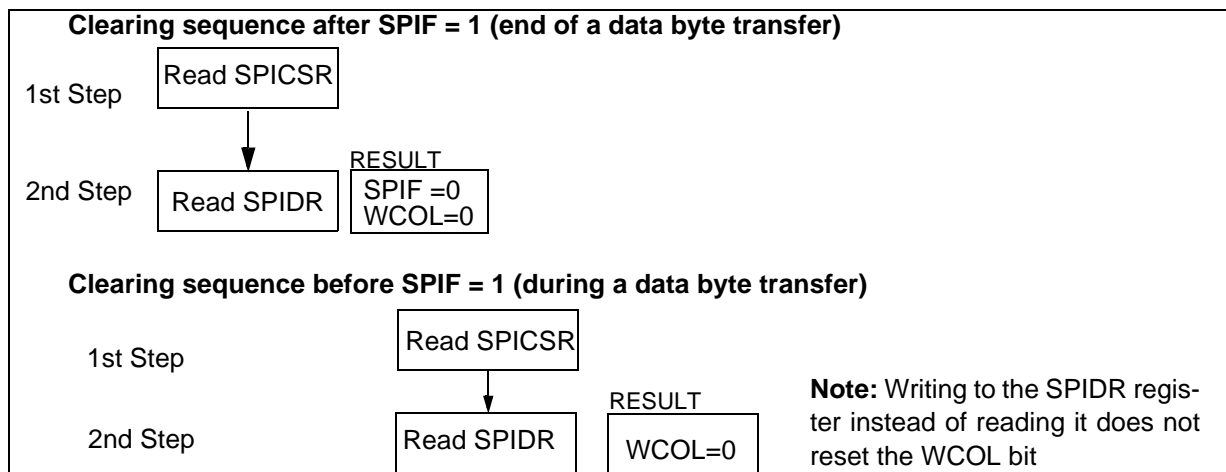

SERIAL PERIPHERAL INTERFACE (Cont'd)

10.5.5.4 Single Master Systems

A typical single master system may be configured, using an MCU as the master and four MCUs as slaves (see [Figure 59](#)).

The master device selects the individual slave devices by using four pins of a parallel port to control the four \overline{SS} pins of the slave devices.

The \overline{SS} pins are pulled high during reset since the master device ports will be forced to be inputs at that time, thus disabling the slave devices.

Note: To prevent a bus conflict on the MISO line the master allows only one active slave device during a transmission.

For more security, the slave device may respond to the master with the received data byte. Then the master will receive the previous byte back from the slave device if all MISO and MOSI pins are connected and the slave has not written to its SPIDR register.

Other transmission security methods can use ports for handshake lines or data bytes with command fields.

Figure 59. Single Master / Multiple Slave Configuration

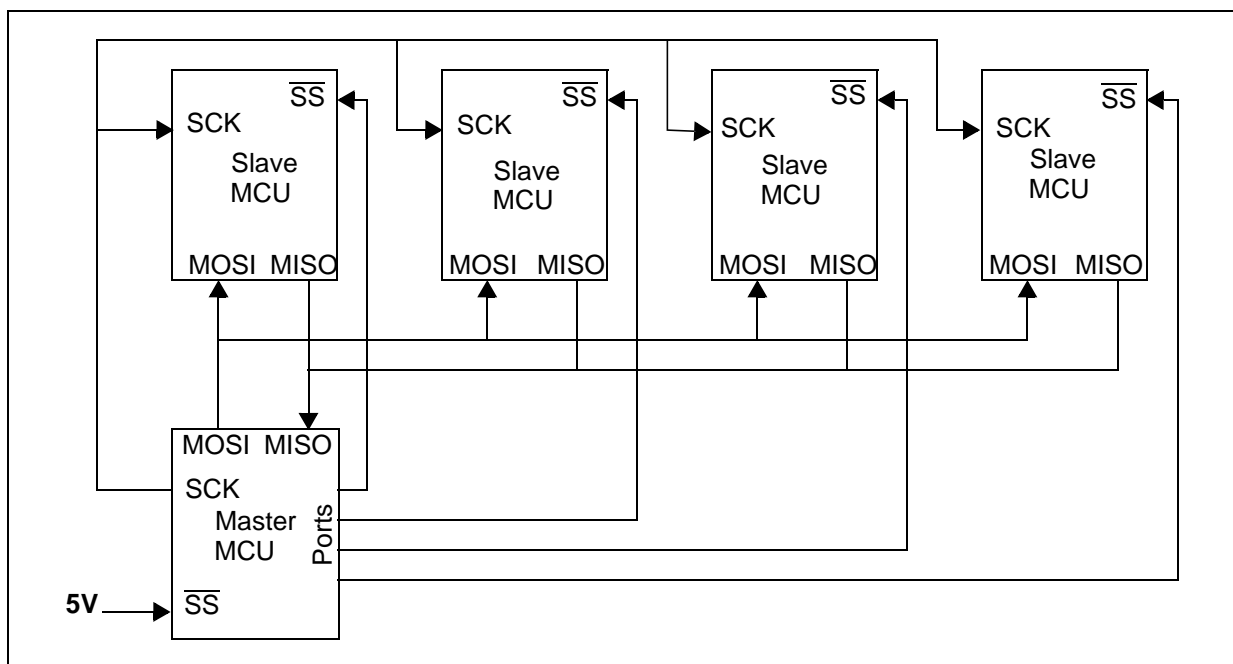

SERIAL PERIPHERAL INTERFACE (Cont'd)

10.5.6 Low Power Modes

Mode	Description
WAIT	No effect on SPI. SPI interrupt events cause the device to exit from WAIT mode.
HALT	SPI registers are frozen. In HALT mode, the SPI is inactive. SPI operation resumes when the MCU is woken up by an interrupt with "exit from HALT mode" capability. The data received is subsequently read from the SPIDR register when the software is running (interrupt vector fetching). If several data are received before the wake-up event, then an overrun error is generated. This error can be detected after the fetch of the interrupt routine that woke up the device.

10.5.6.1 Using the SPI to wakeup the MCU from Halt mode

In slave configuration, the SPI is able to wakeup the ST7 device from HALT mode through a SPIF interrupt. The data received is subsequently read from the SPIDR register when the software is running (interrupt vector fetch). If multiple data transfers have been performed before software clears the SPIF bit, then the OVR bit is set by hardware.

Note: When waking up from Halt mode, if the SPI remains in Slave mode, it is recommended to perform an extra communications cycle to bring the SPI from Halt mode state to normal state. If the SPI exits from Slave mode, it returns to normal state immediately.

Caution: The SPI can wake up the ST7 from Halt mode only if the Slave Select signal (external \overline{SS} pin or the SSI bit in the SPICSR register) is low when the ST7 enters Halt mode. So if Slave selection is configured as external (see [Section 10.5.3.2](#)), make sure the master drives a low level on the \overline{SS} pin when the slave enters Halt mode.

10.5.7 Interrupts

Interrupt Event	Event Flag	Enable Control Bit	Exit from Wait	Exit from Halt
SPI End of Transfer Event	SPIF	SPIE	Yes	Yes
Master Mode Fault Event	MODF		Yes	No
Overrun Error	OVR		Yes	No

Note: The SPI interrupt events are connected to the same interrupt vector (see Interrupts chapter). They generate an interrupt if the corresponding Enable Control Bit is set and the interrupt mask in

SERIAL PERIPHERAL INTERFACE (Cont'd)**10.5.8 Register Description****CONTROL REGISTER (SPICR)**

Read/Write

Reset Value: 0000 xxxx (0xh)

7							0
SPIE	SPE	SPR2	MSTR	CPOL	CPHA	SPR1	SPR0

Bit 7 = **SPIE** *Serial Peripheral Interrupt Enable*.

This bit is set and cleared by software.

0: Interrupt is inhibited

1: An SPI interrupt is generated whenever SPIF=1, MODF=1 or OVR=1 in the SPICSR register

Bit 6 = **SPE** *Serial Peripheral Output Enable*.

This bit is set and cleared by software. It is also cleared by hardware when, in master mode, $\overline{SS}=0$ (see [Section 10.5.5.1 Master Mode Fault \(MODF\)](#)). The SPE bit is cleared by reset, so the SPI peripheral is not initially connected to the external pins.

0: I/O pins free for general purpose I/O

1: SPI I/O pin alternate functions enabled

Bit 5 = **SPR2** *Divider Enable*.

This bit is set and cleared by software and is cleared by reset. It is used with the SPR[1:0] bits to set the baud rate. Refer to [Table 18 SPI Master mode SCK Frequency](#).

0: Divider by 2 enabled

1: Divider by 2 disabled

Note: This bit has no effect in slave mode.

Bit 4 = **MSTR** *Master Mode*.

This bit is set and cleared by software. It is also cleared by hardware when, in master mode, $\overline{SS}=0$ (see [Section 10.5.5.1 Master Mode Fault \(MODF\)](#)).

0: Slave mode

1: Master mode. The function of the SCK pin changes from an input to an output and the functions of the MISO and MOSI pins are reversed.

Bit 3 = **CPOL** *Clock Polarity*.

This bit is set and cleared by software. This bit determines the idle state of the serial Clock. The CPOL bit affects both the master and slave modes.

0: SCK pin has a low level idle state

1: SCK pin has a high level idle state

Note: If CPOL is changed at the communication byte boundaries, the SPI must be disabled by re-setting the SPE bit.

Bit 2 = **CPHA** *Clock Phase*.

This bit is set and cleared by software.

0: The first clock transition is the first data capture edge.

1: The second clock transition is the first capture edge.

Note: The slave must have the same CPOL and CPHA settings as the master.

Bits 1:0 = **SPR[1:0]** *Serial Clock Frequency*.

These bits are set and cleared by software. Used with the SPR2 bit, they select the baud rate of the SPI serial clock SCK output by the SPI in master mode.

Note: These 2 bits have no effect in slave mode.

Table 18. SPI Master mode SCK Frequency

Serial Clock	SPR2	SPR1	SPR0
$f_{CPU}/4$	1	0	0
$f_{CPU}/8$	0	0	0
$f_{CPU}/16$	0	0	1
$f_{CPU}/32$	1	1	0
$f_{CPU}/64$	0	1	0
$f_{CPU}/128$	0	1	1

SERIAL PERIPHERAL INTERFACE (Cont'd)

CONTROL/STATUS REGISTER (SPICSR)

Read/Write (some bits Read Only)
Reset Value: 0000 0000 (00h)

7							0
SPIF	WCOL	OVR	MODF	-	SOD	SSM	SSI

Bit 7 = **SPIF** *Serial Peripheral Data Transfer Flag (Read only)*.

This bit is set by hardware when a transfer has been completed. An interrupt is generated if SPIE=1 in the SPICR register. It is cleared by a software sequence (an access to the SPICSR register followed by a write or a read to the SPIDR register).

0: Data transfer is in progress or the flag has been cleared.

1: Data transfer between the device and an external device has been completed.

Note: While the SPIF bit is set, all writes to the SPIDR register are inhibited until the SPICSR register is read.

Bit 6 = **WCOL** *Write Collision status (Read only)*.

This bit is set by hardware when a write to the SPIDR register is done during a transmit sequence. It is cleared by a software sequence (see [Figure 58](#)).

0: No write collision occurred

1: A write collision has been detected

Bit 5 = **OVR** *SPI Overrun error (Read only)*.

This bit is set by hardware when the byte currently being received in the shift register is ready to be transferred into the SPIDR register while SPIF = 1 (See [Section 10.5.5.2](#)). An interrupt is generated if SPIE = 1 in SPICR register. The OVR bit is cleared by software reading the SPICSR register.

0: No overrun error

1: Overrun error detected

Bit 4 = **MODF** *Mode Fault flag (Read only)*.

This bit is set by hardware when the \overline{SS} pin is pulled low in master mode (see [Section 10.5.5.1 Master Mode Fault \(MODF\)](#)). An SPI interrupt can be generated if SPIE=1 in the SPICSR register. This bit is cleared by a software sequence (An access to the SPICR register while MODF=1 followed by a write to the SPICR register).

0: No master mode fault detected

1: A fault in master mode has been detected

Bit 3 = Reserved, must be kept cleared.

Bit 2 = **SOD** *SPI Output Disable*.

This bit is set and cleared by software. When set, it disables the alternate function of the SPI output (MOSI in master mode / MISO in slave mode)

0: SPI output enabled (if SPE=1)

1: SPI output disabled

Bit 1 = **SSM** \overline{SS} *Management*.

This bit is set and cleared by software. When set, it disables the alternate function of the SPI \overline{SS} pin and uses the SSI bit value instead. See [Section 10.5.3.2 Slave Select Management](#).

0: Hardware management (\overline{SS} managed by external pin)

1: Software management (internal \overline{SS} signal controlled by SSI bit. External \overline{SS} pin free for general-purpose I/O)

Bit 0 = **SSI** \overline{SS} *Internal Mode*.

This bit is set and cleared by software. It acts as a 'chip select' by controlling the level of the \overline{SS} slave select signal when the SSM bit is set.

0 : Slave selected

1 : Slave deselected

DATA I/O REGISTER (SPIDR)

Read/Write

Reset Value: Undefined

7							0
D7	D6	D5	D4	D3	D2	D1	D0

The SPIDR register is used to transmit and receive data on the serial bus. In a master device, a write to this register will initiate transmission/reception of another byte.

Notes: During the last clock cycle the SPIF bit is set, a copy of the received data byte in the shift register is moved to a buffer. When the user reads the serial peripheral data I/O register, the buffer is actually being read.

While the SPIF bit is set, all writes to the SPIDR register are inhibited until the SPICSR register is read.

Warning: A write to the SPIDR register places data directly into the shift register for transmission.

A read to the SPIDR register returns the value located in the buffer and not the content of the shift register (see [Figure 53](#)).

SERIAL PERIPHERAL INTERFACE (Cont'd)

Table 19. SPI Register Map and Reset Values

Address (Hex.)	Register Label	7	6	5	4	3	2	1	0
0021h	SPIDR Reset Value	MSB x	x	x	x	x	x	x	LSB x
0022h	SPICR Reset Value	SPIE 0	SPE 0	SPR2 0	MSTR 0	CPOL x	CPHA x	SPR1 x	SPR0 x
0023h	SPICSR Reset Value	SPIF 0	WCOL 0	OR 0	MODF 0		SOD 0	SSM 0	SSI 0

10.6 SERIAL COMMUNICATIONS INTERFACE (SCI)

10.6.1 Introduction

The Serial Communications Interface (SCI) offers a flexible means of full-duplex data exchange with external equipment requiring an industry standard NRZ asynchronous serial data format. The SCI offers a very wide range of baud rates using two baud rate generator systems.

10.6.2 Main Features

- Full duplex, asynchronous communications
- NRZ standard format (Mark/Space)
- Dual baud rate generator systems
- Independently programmable transmit and receive baud rates up to 500K baud.
- Programmable data word length (8 or 9 bits)
- Receive buffer full, Transmit buffer empty and End of Transmission flags
- Two receiver wake-up modes:
 - Address bit (MSB)
 - Idle line
- Muting function for multiprocessor configurations
- Separate enable bits for Transmitter and Receiver
- Four error detection flags:
 - Overrun error
 - Noise error
 - Frame error
 - Parity error
- Five interrupt sources with flags:
 - Transmit data register empty
 - Transmission complete
 - Receive data register full
 - Idle line received
 - Overrun error detected
- Parity control:
 - Transmits parity bit
 - Checks parity of received data byte
- Reduced power consumption mode

10.6.3 General Description

The interface is externally connected to another device by two pins (see [Figure 61](#)):

- TDO: Transmit Data Output. When the transmitter and the receiver are disabled, the output pin returns to its I/O port configuration. When the transmitter and/or the receiver are enabled and nothing is to be transmitted, the TDO pin is at high level.
- RDI: Receive Data Input is the serial data input. Oversampling techniques are used for data recovery by discriminating between valid incoming data and noise.

Through these pins, serial data is transmitted and received as frames comprising:

- An Idle Line prior to transmission or reception
- A start bit
- A data word (8 or 9 bits) least significant bit first
- A Stop bit indicating that the frame is complete.

This interface uses two types of baud rate generator:

- A conventional type for commonly-used baud rates,
- An extended type with a prescaler offering a very wide range of baud rates even with non-standard oscillator frequencies.

SERIAL COMMUNICATIONS INTERFACE (Cont'd)

Figure 60. SCI Block Diagram

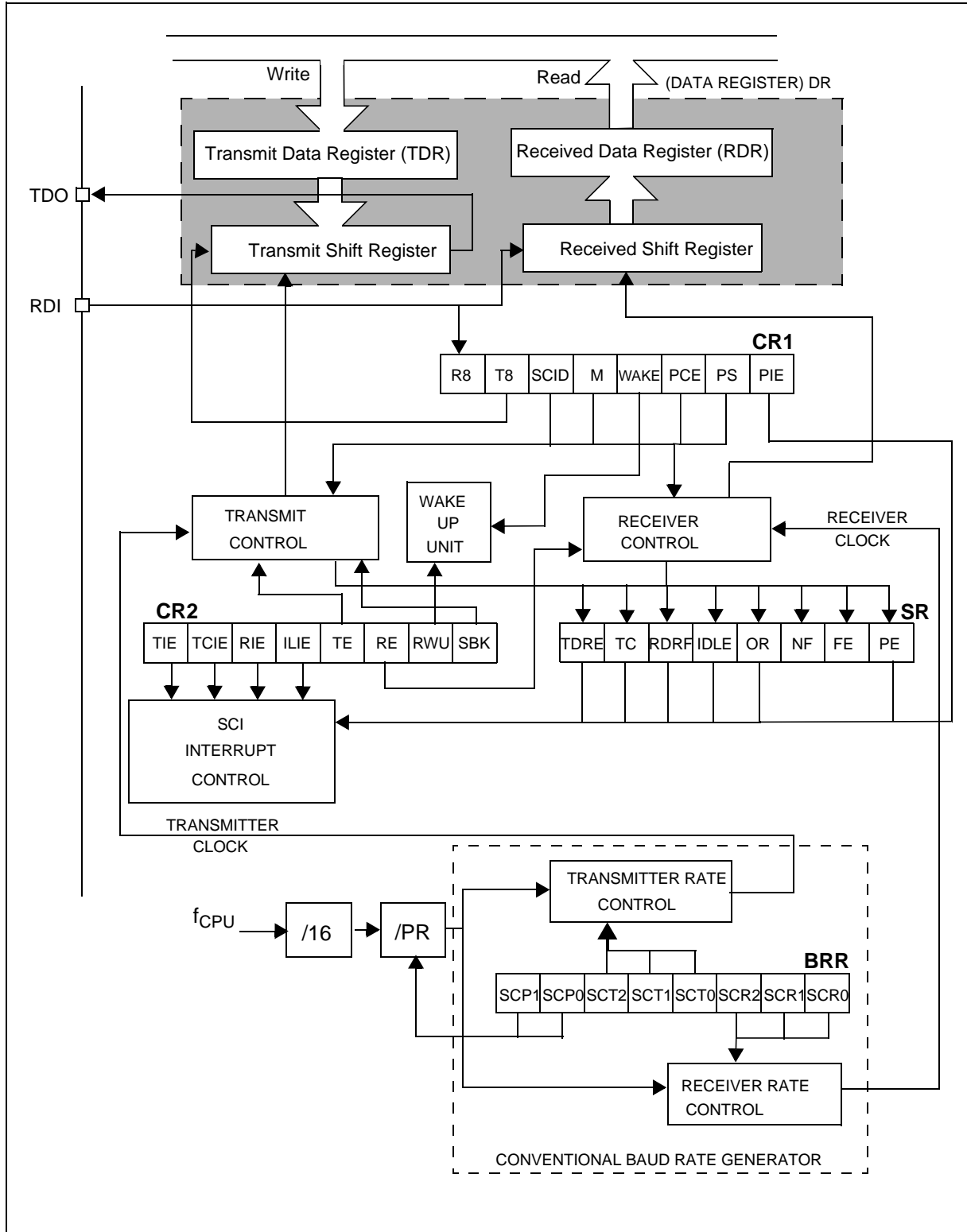

SERIAL COMMUNICATIONS INTERFACE (Cont'd)

10.6.4 Functional Description

The block diagram of the Serial Control Interface, is shown in [Figure 60](#). It contains 6 dedicated registers:

- Two control registers (SCICR1 & SCICR2)
- A status register (SCISR)
- A baud rate register (SCIBRR)
- An extended prescaler receiver register (SCIERP)
- An extended prescaler transmitter register (SCIETPR)

Refer to the register descriptions in [Section 10.6.7](#) for the definitions of each bit.

10.6.4.1 Serial Data Format

Word length may be selected as being either 8 or 9 bits by programming the M bit in the SCICR1 register (see [Figure 60](#)).

The TDO pin is in low state during the start bit.

The TDO pin is in high state during the stop bit.

An Idle character is interpreted as an entire frame of "1"s followed by the start bit of the next frame which contains data.

A Break character is interpreted on receiving "0"s for some multiple of the frame period. At the end of the last break frame the transmitter inserts an extra "1" bit to acknowledge the start bit.

Transmission and reception are driven by their own baud rate generator.

Figure 61. Word Length Programming

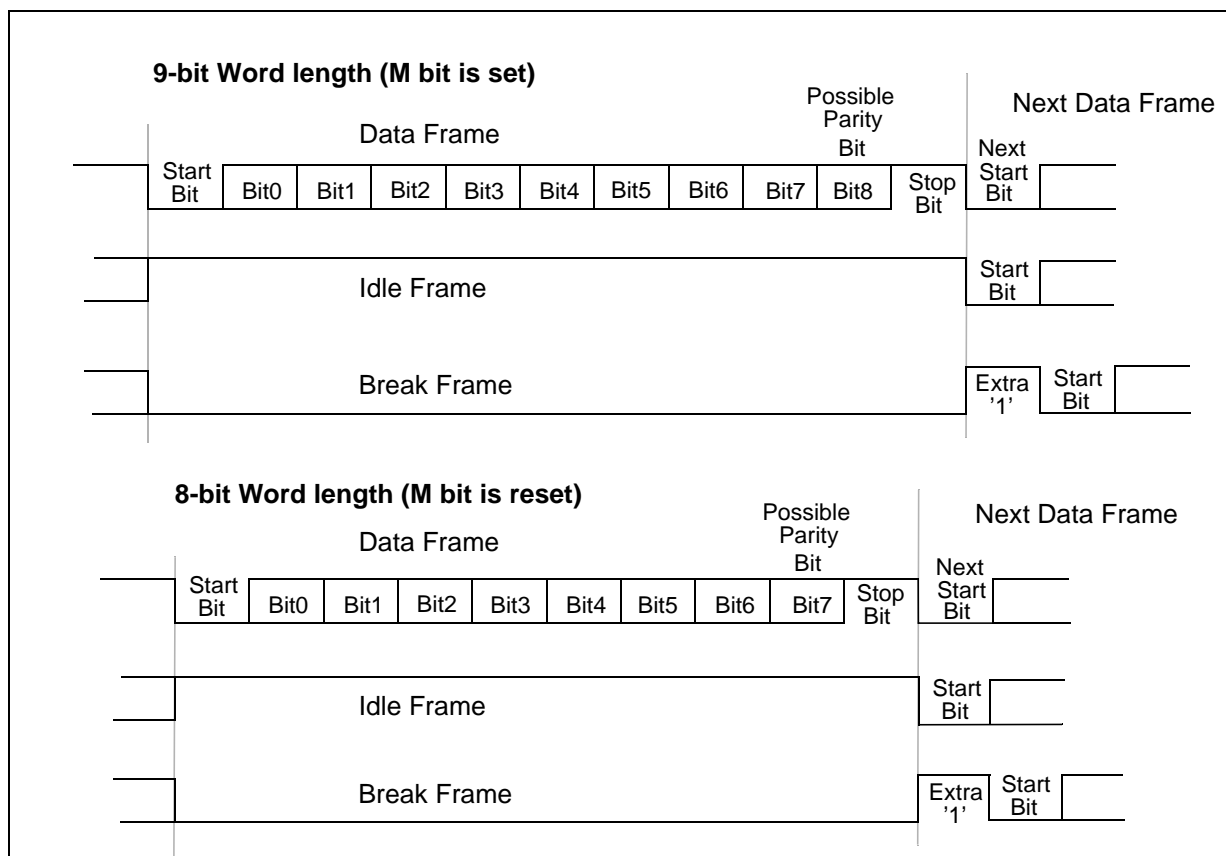

SERIAL COMMUNICATIONS INTERFACE (Cont'd)**10.6.4.2 Transmitter**

The transmitter can send data words of either 8 or 9 bits depending on the M bit status. When the M bit is set, word length is 9 bits and the 9th bit (the MSB) has to be stored in the T8 bit in the SCICR1 register.

Character Transmission

During an SCI transmission, data shifts out least significant bit first on the TDO pin. In this mode, the SCIDR register consists of a buffer (TDR) between the internal bus and the transmit shift register (see [Figure 60](#)).

Procedure

- Select the M bit to define the word length.
- Select the desired baud rate using the SCIBRR and the SCIETPR registers.
- Set the TE bit to assign the TDO pin to the alternate function and to send a idle frame as first transmission.
- Access the SCISR register and write the data to send in the SCIDR register (this sequence clears the TDRE bit). Repeat this sequence for each data to be transmitted.

Clearing the TDRE bit is always performed by the following software sequence:

1. An access to the SCISR register
2. A write to the SCIDR register

The TDRE bit is set by hardware and it indicates:

- The TDR register is empty.
- The data transfer is beginning.
- The next data can be written in the SCIDR register without overwriting the previous data.

This flag generates an interrupt if the TIE bit is set and the I bit is cleared in the CCR register.

When a transmission is taking place, a write instruction to the SCIDR register stores the data in the TDR register and which is copied in the shift register at the end of the current transmission.

When no transmission is taking place, a write instruction to the SCIDR register places the data directly in the shift register, the data transmission starts, and the TDRE bit is immediately set.

When a frame transmission is complete (after the stop bit or after the break frame) the TC bit is set and an interrupt is generated if the TCIE is set and the I bit is cleared in the CCR register.

Clearing the TC bit is performed by the following software sequence:

1. An access to the SCISR register
2. A write to the SCIDR register

Note: The TDRE and TC bits are cleared by the same software sequence.

Break Characters

Setting the SBK bit loads the shift register with a break character. The break frame length depends on the M bit (see [Figure 61](#)).

As long as the SBK bit is set, the SCI send break frames to the TDO pin. After clearing this bit by software the SCI insert a logic 1 bit at the end of the last break frame to guarantee the recognition of the start bit of the next frame.

Idle Characters

Setting the TE bit drives the SCI to send an idle frame before the first data frame.

Clearing and then setting the TE bit during a transmission sends an idle frame after the current word.

Note: Resetting and setting the TE bit causes the data in the TDR register to be lost. Therefore the best time to toggle the TE bit is when the TDRE bit is set i.e. before writing the next byte in the SCIDR.

SERIAL COMMUNICATIONS INTERFACE (Cont'd)**10.6.4.3 Receiver**

The SCI can receive data words of either 8 or 9 bits. When the M bit is set, word length is 9 bits and the MSB is stored in the R8 bit in the SCICR1 register.

Character reception

During a SCI reception, data shifts in least significant bit first through the RDI pin. In this mode, the SCIDR register consists of a buffer (RDR) between the internal bus and the received shift register (see [Figure 60](#)).

Procedure

- Select the M bit to define the word length.
- Select the desired baud rate using the SCIBRR and the SCIERPR registers.
- Set the RE bit, this enables the receiver which begins searching for a start bit.

When a character is received:

- The RDRF bit is set. It indicates that the content of the shift register is transferred to the RDR.
- An interrupt is generated if the RIE bit is set and the I bit is cleared in the CCR register.
- The error flags can be set if a frame error, noise or an overrun error has been detected during reception.

Clearing the RDRF bit is performed by the following software sequence done by:

1. An access to the SCISR register
2. A read to the SCIDR register.

The RDRF bit must be cleared before the end of the reception of the next character to avoid an overrun error.

Break Character

When a break character is received, the SPI handles it as a framing error.

Idle Character

When an idle frame is detected, there is the same procedure as a data received character plus an interrupt if the ILIE bit is set and the I bit is cleared in the CCR register.

Overrun Error

An overrun error occurs when a character is received when RDRF has not been reset. Data can not be transferred from the shift register to the

RDR register as long as the RDRF bit is not cleared.

When an overrun error occurs:

- The OR bit is set.
- The RDR content will not be lost.
- The shift register will be overwritten.
- An interrupt is generated if the RIE bit is set and the I bit is cleared in the CCR register.

The OR bit is reset by an access to the SCISR register followed by a SCIDR register read operation.

Noise Error

Oversampling techniques are used for data recovery by discriminating between valid incoming data and noise. Normal data bits are considered valid if three consecutive samples (8th, 9th, 10th) have the same bit value, otherwise the NF flag is set. In the case of start bit detection, the NF flag is set on the basis of an algorithm combining both valid edge detection and three samples (8th, 9th, 10th). Therefore, to prevent the NF flag getting set during start bit reception, there should be a valid edge detection as well as three valid samples.

When noise is detected in a frame:

- The NF flag is set at the rising edge of the RDRF bit.
- Data is transferred from the Shift register to the SCIDR register.
- No interrupt is generated. However this bit rises at the same time as the RDRF bit which itself generates an interrupt.

The NF flag is reset by a SCISR register read operation followed by a SCIDR register read operation.

During reception, if a false start bit is detected (e.g. 8th, 9th, 10th samples are 011,101,110), the frame is discarded and the receiving sequence is not started for this frame. There is no RDRF bit set for this frame and the NF flag is set internally (not accessible to the user). This NF flag is accessible along with the RDRF bit when a next valid frame is received.

Note: If the application Start Bit is not long enough to match the above requirements, then the NF Flag may get set due to the short Start Bit. In this case, the NF flag may be ignored by the application software when the first valid byte is received.

See also [Section 10.6.4.10](#).

SERIAL COMMUNICATIONS INTERFACE (Cont'd)

Figure 62. SCI Baud Rate and Extended Prescaler Block Diagram

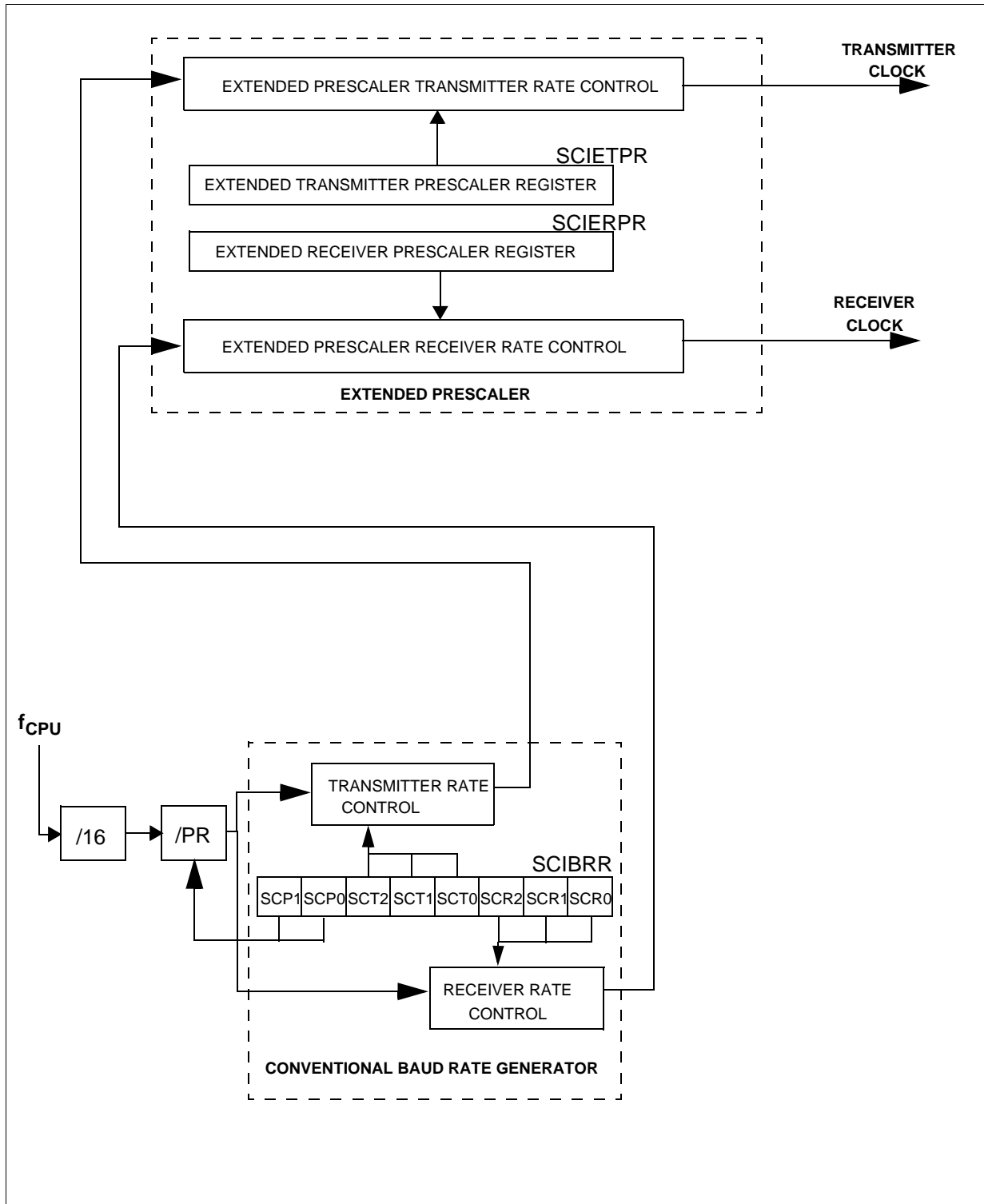

SERIAL COMMUNICATIONS INTERFACE (Cont'd)**Framing Error**

A framing error is detected when:

- The stop bit is not recognized on reception at the expected time, following either a de-synchronization or excessive noise.
- A break is received.

When the framing error is detected:

- the FE bit is set by hardware
- Data is transferred from the Shift register to the SCIDR register.
- No interrupt is generated. However this bit rises at the same time as the RDRF bit which itself generates an interrupt.

The FE bit is reset by a SCISR register read operation followed by a SCIDR register read operation.

10.6.4.4 Conventional Baud Rate Generation

The baud rate for the receiver and transmitter (Rx and Tx) are set independently and calculated as follows:

$$Tx = \frac{f_{CPU}}{(16 \cdot PR) \cdot TR} \quad Rx = \frac{f_{CPU}}{(16 \cdot PR) \cdot RR}$$

with:

PR = 1, 3, 4 or 13 (see SCP[1:0] bits)

TR = 1, 2, 4, 8, 16, 32, 64, 128

(see SCT[2:0] bits)

RR = 1, 2, 4, 8, 16, 32, 64, 128

(see SCR[2:0] bits)

All these bits are in the SCIBRR register.

Example: If f_{CPU} is 8 MHz (normal mode) and if PR=13 and TR=RR=1, the transmit and receive baud rates are 38400 baud.

Note: the baud rate registers MUST NOT be changed while the transmitter or the receiver is enabled.

10.6.4.5 Extended Baud Rate Generation

The extended prescaler option gives a very fine tuning on the baud rate, using a 255 value prescaler, whereas the conventional Baud Rate Generator retains industry standard software compatibility.

The extended baud rate generator block diagram is described in the [Figure 62](#).

The output clock rate sent to the transmitter or to the receiver will be the output from the 16 divider divided by a factor ranging from 1 to 255 set in the SCIERPR or the SCIETPR register.

Note: the extended prescaler is activated by setting the SCIETPR or SCIERPR register to a value other than zero. The baud rates are calculated as follows:

$$Tx = \frac{f_{CPU}}{16 \cdot ETPR \cdot (PR \cdot TR)} \quad Rx = \frac{f_{CPU}}{16 \cdot ERPR \cdot (PR \cdot RR)}$$

with:

ETPR = 1,...,255 (see SCIETPR register)

ERPR = 1,.. 255 (see SCIERPR register)

10.6.4.6 Receiver Muting and Wake-up Feature

In multiprocessor configurations it is often desirable that only the intended message recipient should actively receive the full message contents, thus reducing redundant SCI service overhead for all non addressed receivers.

The non addressed devices may be placed in sleep mode by means of the muting function.

Setting the RWU bit by software puts the SCI in sleep mode:

All the reception status bits can not be set.

All the receive interrupts are inhibited.

A muted receiver may be awakened by one of the following two ways:

- by Idle Line detection if the WAKE bit is reset,
- by Address Mark detection if the WAKE bit is set.

Receiver wakes-up by Idle Line detection when the Receive line has recognised an Idle Frame. Then the RWU bit is reset by hardware but the IDLE bit is not set.

Receiver wakes-up by Address Mark detection when it received a "1" as the most significant bit of a word, thus indicating that the message is an address. The reception of this particular word wakes up the receiver, resets the RWU bit and sets the RDRF bit, which allows the receiver to receive this word normally and to use it as an address word.

Caution: In Mute mode, do not write to the SCICR2 register. If the SCI is in Mute mode during the read operation (RWU=1) and a address mark wake up event occurs (RWU is reset) before the write operation, the RWU bit will be set again by this write operation. Consequently the address byte is lost and the SCI is not woken up from Mute mode.

SERIAL COMMUNICATIONS INTERFACE (Cont'd)**10.6.4.7 Parity Control**

Parity control (generation of parity bit in transmission and parity checking in reception) can be enabled by setting the PCE bit in the SCICR1 register. Depending on the frame length defined by the M bit, the possible SCI frame formats are as listed in Table 20.

Table 20. Frame Formats

M bit	PCE bit	SCI frame
0	0	SB 8 bit data STB
0	1	SB 7-bit data PB STB
1	0	SB 9-bit data STB
1	1	SB 8-bit data PB STB

Legend: SB = Start Bit, STB = Stop Bit, PB = Parity Bit

Note: In case of wake up by an address mark, the MSB bit of the data is taken into account and not the parity bit

Even parity: the parity bit is calculated to obtain an even number of “1s” inside the frame made of the 7 or 8 LSB bits (depending on whether M is equal to 0 or 1) and the parity bit.

Ex: data=00110101; 4 bits set => parity bit will be 0 if even parity is selected (PS bit = 0).

Odd parity: the parity bit is calculated to obtain an odd number of “1s” inside the frame made of the 7 or 8 LSB bits (depending on whether M is equal to 0 or 1) and the parity bit.

Ex: data=00110101; 4 bits set => parity bit will be 1 if odd parity is selected (PS bit = 1).

Transmission mode: If the PCE bit is set then the MSB bit of the data written in the data register is not transmitted but is changed by the parity bit.

Reception mode: If the PCE bit is set then the interface checks if the received data byte has an

even number of “1s” if even parity is selected (PS=0) or an odd number of “1s” if odd parity is selected (PS=1). If the parity check fails, the PE flag is set in the SCISR register and an interrupt is generated if PIE is set in the SCICR1 register.

10.6.4.8 SCI Clock Tolerance

During reception, each bit is sampled 16 times. The majority of the 8th, 9th and 10th samples is considered as the bit value. For a valid bit detection, all the three samples should have the same value otherwise the noise flag (NF) is set. For example: if the 8th, 9th and 10th samples are 0, 1 and 1 respectively, then the bit value will be “1”, but the Noise Flag bit is set because the three samples values are not the same.

Consequently, the bit length must be long enough so that the 8th, 9th and 10th samples have the desired bit value. This means the clock frequency should not vary more than 6/16 (37.5%) within one bit. The sampling clock is resynchronized at each start bit, so that when receiving 10 bits (one start bit, 1 data byte, 1 stop bit), the clock deviation must not exceed 3.75%.

Note: The internal sampling clock of the microcontroller samples the pin value on every falling edge. Therefore, the internal sampling clock and the time the application expects the sampling to take place may be out of sync. For example: If the baud rate is 15.625 kbaud (bit length is 64µs), then the 8th, 9th and 10th samples will be at 28µs, 32µs & 36µs respectively (the first sample starting ideally at 0µs). But if the falling edge of the internal clock occurs just before the pin value changes, the samples would then be out of sync by ~4µs. This means the entire bit length must be at least 40µs (36µs for the 10th sample + 4µs for synchronization with the internal sampling clock).

SERIAL COMMUNICATIONS INTERFACE (Cont'd)

10.6.4.9 Clock Deviation Causes

The causes which contribute to the total deviation are:

- D_{TRA} : Deviation due to transmitter error (Local oscillator error of the transmitter or the transmitter is transmitting at a different baud rate).
- D_{QUANT} : Error due to the baud rate quantisation of the receiver.
- D_{REC} : Deviation of the local oscillator of the receiver: This deviation can occur during the reception of one complete SCI message assuming that the deviation has been compensated at the beginning of the message.
- D_{TCL} : Deviation due to the transmission line (generally due to the transceivers)

All the deviations of the system should be added and compared to the SCI clock tolerance:

$$D_{TRA} + D_{QUANT} + D_{REC} + D_{TCL} < 3.75\%$$

10.6.4.10 Noise Error Causes

See also description of Noise error in [Section 10.6.4.3](#).

Start bit

The noise flag (NF) is set during start bit reception if one of the following conditions occurs:

1. A valid falling edge is not detected. A falling edge is considered to be valid if the 3 consecutive samples before the falling edge occurs are detected as '1' and, after the falling edge occurs, during the sampling of the 16 samples, if one of the samples numbered 3, 5 or 7 is detected as a "1".
2. During sampling of the 16 samples, if one of the samples numbered 8, 9 or 10 is detected as a "1".

Therefore, a valid Start Bit must satisfy both the above conditions to prevent the Noise Flag getting set.

Data Bits

The noise flag (NF) is set during normal data bit reception if the following condition occurs:

- During the sampling of 16 samples, if all three samples numbered 8, 9 and 10 are not the same. The majority of the 8th, 9th and 10th samples is considered as the bit value.

Therefore, a valid Data Bit must have samples 8, 9 and 10 at the same value to prevent the Noise Flag getting set.

Figure 63. Bit Sampling in Reception Mode

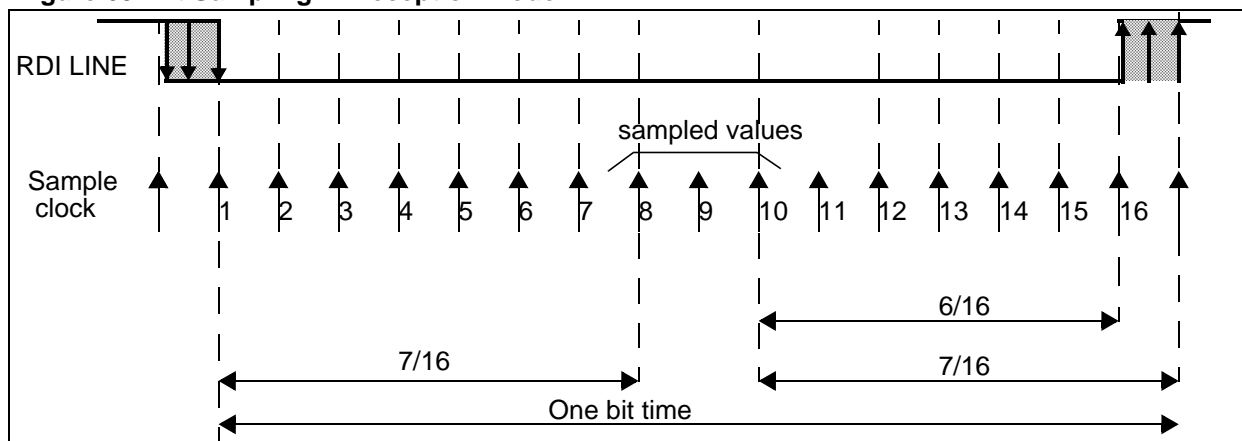

SERIAL COMMUNICATIONS INTERFACE (Cont'd)**10.6.5 Low Power Modes**

Mode	Description
WAIT	No effect on SCI. SCI interrupts cause the device to exit from Wait mode.
HALT	SCI registers are frozen. In Halt mode, the SCI stops transmitting/receiving until Halt mode is exited.

10.6.6 Interrupts

The SCI interrupt events are connected to the same interrupt vector.

These events generate an interrupt if the corresponding Enable Control Bit is set and the inter-

Interrupt Event	Event Flag	Enable Control Bit	Exit from Wait	Exit from Halt
Transmit Data Register Empty	TDRE	TIE	Yes	No
Transmission Complete	TC	TCIE	Yes	No
Received Data Ready to be Read	RDRF	RIE	Yes	No
Overrun Error Detected	OR		Yes	No
Idle Line Detected	IDLE	ILIE	Yes	No
Parity Error	PE	PIE	Yes	No

rupt mask in the CC register is reset (RIM instruction).

SERIAL COMMUNICATIONS INTERFACE (Cont'd)

10.6.7 Register Description

STATUS REGISTER (SCISR)

Read Only

Reset Value: 1100 0000 (C0h)

7							0
TDRE	TC	RDRF	IDLE	OR	NF	FE	PE

Bit 7 = **TDRE** *Transmit data register empty.*
 This bit is set by hardware when the content of the TDR register has been transferred into the shift register. An interrupt is generated if the TIE bit=1 in the SCICR2 register. It is cleared by a software sequence (an access to the SCISR register followed by a write to the SCIDR register).
 0: Data is not transferred to the shift register
 1: Data is transferred to the shift register

Note: Data will not be transferred to the shift register unless the TDRE bit is cleared.

Bit 6 = **TC** *Transmission complete.*
 This bit is set by hardware when transmission of a frame containing Data is complete. An interrupt is generated if TCIE=1 in the SCICR2 register. It is cleared by a software sequence (an access to the SCISR register followed by a write to the SCIDR register).
 0: Transmission is not complete
 1: Transmission is complete

Note: TC is not set after the transmission of a Preamble or a Break.

Bit 5 = **RDRF** *Received data ready flag.*
 This bit is set by hardware when the content of the RDR register has been transferred to the SCIDR register. An interrupt is generated if RIE=1 in the SCICR2 register. It is cleared by a software sequence (an access to the SCISR register followed by a read to the SCIDR register).
 0: Data is not received
 1: Received data is ready to be read

Bit 4 = **IDLE** *Idle line detect.*
 This bit is set by hardware when an Idle Line is detected. An interrupt is generated if the ILIE=1 in the SCICR2 register. It is cleared by a software sequence (an access to the SCISR register followed by a read to the SCIDR register).
 0: No Idle Line is detected
 1: Idle Line is detected

Note: The IDLE bit will not be set again until the RDRF bit has been set itself (i.e. a new idle line occurs).

Bit 3 = **OR** *Overrun error.*
 This bit is set by hardware when the word currently being received in the shift register is ready to be transferred into the RDR register while RDRF=1. An interrupt is generated if RIE=1 in the SCICR2 register. It is cleared by a software sequence (an access to the SCISR register followed by a read to the SCIDR register).
 0: No Overrun error
 1: Overrun error is detected

Note: When this bit is set RDR register content will not be lost but the shift register will be overwritten.

Bit 2 = **NF** *Noise flag.*
 This bit is set by hardware when noise is detected on a received frame. It is cleared by a software sequence (an access to the SCISR register followed by a read to the SCIDR register).
 0: No noise is detected
 1: Noise is detected

Note: This bit does not generate interrupt as it appears at the same time as the RDRF bit which itself generates an interrupt.

Bit 1 = **FE** *Framing error.*
 This bit is set by hardware when a de-synchronization, excessive noise or a break character is detected. It is cleared by a software sequence (an access to the SCISR register followed by a read to the SCIDR register).
 0: No Framing error is detected
 1: Framing error or break character is detected

Note: This bit does not generate interrupt as it appears at the same time as the RDRF bit which itself generates an interrupt. If the word currently being transferred causes both frame error and overrun error, it will be transferred and only the OR bit will be set.

Bit 0 = **PE** *Parity error.*
 This bit is set by hardware when a parity error occurs in receiver mode. It is cleared by a software sequence (a read to the status register followed by an access to the SCIDR data register). An interrupt is generated if PIE=1 in the SCICR1 register.
 0: No parity error
 1: Parity error

SERIAL COMMUNICATIONS INTERFACE (Cont'd)**CONTROL REGISTER 1 (SCICR1)**

Read/Write

Reset Value: x000 0000 (x0h)

7							0
R8	T8	SCID	M	WAKE	PCE	PS	PIE

Bit 7 = R8 *Receive data bit 8.*

This bit is used to store the 9th bit of the received word when M=1.

Bit 6 = T8 *Transmit data bit 8.*

This bit is used to store the 9th bit of the transmitted word when M=1.

Bit 5 = SCID *Disabled for low power consumption*

When this bit is set the SCI prescalers and outputs are stopped and the end of the current byte transfer in order to reduce power consumption. This bit is set and cleared by software.

0: SCI enabled

1: SCI prescaler and outputs disabled

Bit 4 = M *Word length.*

This bit determines the word length. It is set or cleared by software.

0: 1 Start bit, 8 Data bits, 1 Stop bit

1: 1 Start bit, 9 Data bits, 1 Stop bit

Note: The M bit must not be modified during a data transfer (both transmission and reception).**Bit 3 = WAKE** *Wake-Up method.*

This bit determines the SCI Wake-Up method, it is set or cleared by software.

0: Idle Line

1: Address Mark

Bit 2 = PCE *Parity control enable.*

This bit selects the hardware parity control (generation and detection). When the parity control is enabled, the computed parity is inserted at the MSB position (9th bit if M=1; 8th bit if M=0) and parity is checked on the received data. This bit is set and cleared by software. Once it is set, PCE is active after the current byte (in reception and in transmission).

0: Parity control disabled

1: Parity control enabled

Bit 1 = PS *Parity selection.*

This bit selects the odd or even parity when the parity generation/detection is enabled (PCE bit set). It is set and cleared by software. The parity will be selected after the current byte.

0: Even parity

1: Odd parity

Bit 0 = PIE *Parity interrupt enable.*

This bit enables the interrupt capability of the hardware parity control when a parity error is detected (PE bit set). It is set and cleared by software.

0: Parity error interrupt disabled

1: Parity error interrupt enabled.

SERIAL COMMUNICATIONS INTERFACE (Cont'd)

CONTROL REGISTER 2 (SCICR2)

Read/Write

Reset Value: 0000 0000 (00h)

7							0
TIE	TCIE	RIE	ILIE	TE	RE	RWU	SBK

Bit 7 = **TIE** *Transmitter interrupt enable*.
 This bit is set and cleared by software.
 0: Interrupt is inhibited
 1: An SCI interrupt is generated whenever TDRE=1 in the SCISR register

Bit 6 = **TCIE** *Transmission complete interrupt enable*
 This bit is set and cleared by software.
 0: Interrupt is inhibited
 1: An SCI interrupt is generated whenever TC=1 in the SCISR register

Bit 5 = **RIE** *Receiver interrupt enable*.
 This bit is set and cleared by software.
 0: Interrupt is inhibited
 1: An SCI interrupt is generated whenever OR=1 or RDRF=1 in the SCISR register

Bit 4 = **ILIE** *Idle line interrupt enable*.
 This bit is set and cleared by software.
 0: Interrupt is inhibited
 1: An SCI interrupt is generated whenever IDLE=1 in the SCISR register.

Bit 3 = **TE** *Transmitter enable*.
 This bit enables the transmitter. It is set and cleared by software.
 0: Transmitter is disabled
 1: Transmitter is enabled

Notes:

- During transmission, a “0” pulse on the TE bit (“0” followed by “1”) sends a preamble (idle line) after the current word.
- When TE is set there is a 1 bit-time delay before the transmission starts.

Caution: The TDO pin is free for general purpose I/O only when the TE and RE bits are both cleared (or if TE is never set).

Bit 2 = **RE** *Receiver enable*.
 This bit enables the receiver. It is set and cleared by software.
 0: Receiver is disabled
 1: Receiver is enabled and begins searching for a start bit

Bit 1 = **RWU** *Receiver wake-up*.
 This bit determines if the SCI is in mute mode or not. It is set and cleared by software and can be cleared by hardware when a wake-up sequence is recognized.
 0: Receiver in Active mode
 1: Receiver in Mute mode

Note: Before selecting Mute mode (setting the RWU bit), the SCI must receive some data first, otherwise it cannot function in Mute mode with wakeup by idle line detection.

Bit 0 = **SBK** *Send break*.
 This bit set is used to send break characters. It is set and cleared by software.
 0: No break character is transmitted
 1: Break characters are transmitted

Note: If the SBK bit is set to “1” and then to “0”, the transmitter will send a BREAK word at the end of the current word.

SERIAL COMMUNICATIONS INTERFACE (Cont'd)

DATA REGISTER (SCIDR)

Read/Write

Reset Value: Undefined

Contains the Received or Transmitted data character, depending on whether it is read from or written to.

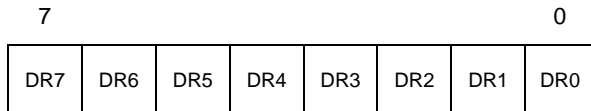

The Data register performs a double function (read and write) since it is composed of two registers, one for transmission (TDR) and one for reception (RDR).

The TDR register provides the parallel interface between the internal bus and the output shift register (see [Figure 60](#)).

The RDR register provides the parallel interface between the input shift register and the internal bus (see [Figure 60](#)).

BAUD RATE REGISTER (SCIBRR)

Read/Write

Reset Value: 0000 0000 (00h)

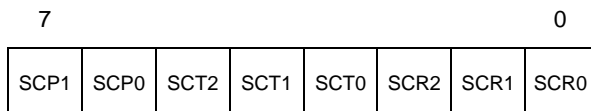

Bits 7:6= **SCP[1:0]** *First SCI Prescaler*

These 2 prescaling bits allow several standard clock division ranges:

PR Prescaling factor	SCP1	SCP0
1	0	0
3	0	1
4	1	0
13	1	1

Bits 5:3 = **SCT[2:0]** *SCI Transmitter rate divisor*

These 3 bits, in conjunction with the SCP1 & SCP0 bits define the total division applied to the bus clock to yield the transmit rate clock in conventional Baud Rate Generator mode.

TR dividing factor	SCT2	SCT1	SCT0
1	0	0	0
2	0	0	1
4	0	1	0
8	0	1	1
16	1	0	0
32	1	0	1
64	1	1	0
128	1	1	1

Bits 2:0 = **SCR[2:0]** *SCI Receiver rate divisor.*

These 3 bits, in conjunction with the SCP[1:0] bits define the total division applied to the bus clock to yield the receive rate clock in conventional Baud Rate Generator mode.

RR Dividing factor	SCR2	SCR1	SCR0
1	0	0	0
2	0	0	1
4	0	1	0
8	0	1	1
16	1	0	0
32	1	0	1
64	1	1	0
128	1	1	1

SERIAL COMMUNICATIONS INTERFACE (Cont'd)

EXTENDED RECEIVE PRESCALER DIVISION REGISTER (SCIERP)

Read/Write

Reset Value: 0000 0000 (00h)

Allows setting of the Extended Prescaler rate division factor for the receive circuit.

7							0
ERPR 7	ERPR 6	ERPR 5	ERPR 4	ERPR 3	ERPR 2	ERPR 1	ERPR 0

Bits 7:0 = **ERPR[7:0]** 8-bit Extended Receive Prescaler Register.

The extended Baud Rate Generator is activated when a value different from 00h is stored in this register. Therefore the clock frequency issued from the 16 divider (see Figure 62) is divided by the binary factor set in the SCIERP register (in the range 1 to 255).

The extended baud rate generator is not used after a reset.

EXTENDED TRANSMIT PRESCALER DIVISION REGISTER (SCIETPR)

Read/Write

Reset Value:0000 0000 (00h)

Allows setting of the External Prescaler rate division factor for the transmit circuit.

7							0
ETPR 7	ETPR 6	ETPR 5	ETPR 4	ETPR 3	ETPR 2	ETPR 1	ETPR 0

Bits 7:0 = **ETPR[7:0]** 8-bit Extended Transmit Prescaler Register.

The extended Baud Rate Generator is activated when a value different from 00h is stored in this register. Therefore the clock frequency issued from the 16 divider (see Figure 62) is divided by the binary factor set in the SCIETPR register (in the range 1 to 255).

The extended baud rate generator is not used after a reset.

Table 21. Baudrate Selection

Symbol	Parameter	Conditions			Standard	Baud Rate	Unit
		f _{CPU}	Accuracy vs. Standard	Prescaler			
f _{Tx} f _{Rx}	Communication frequency	8MHz	~0.16%	Conventional Mode TR (or RR)=128, PR=13 TR (or RR)= 32, PR=13 TR (or RR)= 16, PR=13 TR (or RR)= 8, PR=13 TR (or RR)= 4, PR=13 TR (or RR)= 16, PR= 3 TR (or RR)= 2, PR=13 TR (or RR)= 1, PR=13	300 1200 2400 4800 9600 10400 19200 38400	~300.48 ~1201.92 ~2403.84 ~4807.69 ~9615.38 ~10416.67 ~19230.77 ~38461.54	Hz
				~0.79%	Extended Mode ETPR (or ERPR) = 35, TR (or RR)= 1, PR=1	14400	

SERIAL COMMUNICATION INTERFACE (Cont'd)

Table 22. SCI Register Map and Reset Values

Address (Hex.)	Register Label	7	6	5	4	3	2	1	0
0050h	SCISR Reset Value	TDRE 1	TC 1	RDRF 0	IDLE 0	OR 0	NF 0	FE 0	PE 0
0051h	SCIDR Reset Value	MSB x	x	x	x	x	x	x	LSB x
0052h	SCIBRR Reset Value	SCP1 0	SCP0 0	SCT2 0	SCT1 0	SCT0 0	SCR2 0	SCR1 0	SCR0 0
0053h	SCICR1 Reset Value	R8 x	T8 0	SCID 0	M 0	WAKE 0	PCE 0	PS 0	PIE 0
0054h	SCICR2 Reset Value	TIE 0	TCIE 0	RIE 0	ILIE 0	TE 0	RE 0	RWU 0	SBK 0
0055h	SCIERPR Reset Value	MSB 0	0	0	0	0	0	0	LSB 0
0057h	SCIPETPR Reset Value	MSB 0	0	0	0	0	0	0	LSB 0

10.7 I²C BUS INTERFACE (I2C)

10.7.1 Introduction

The I²C Bus Interface serves as an interface between the microcontroller and the serial I²C bus. It provides both multimaster and slave functions, and controls all I²C bus-specific sequencing, protocol, arbitration and timing. It supports fast I²C mode (400kHz).

10.7.2 Main Features

- Parallel-bus/I²C protocol converter
- Multi-master capability
- 7-bit/10-bit Addressing
- SMBus V1.1 Compliant
- Transmitter/Receiver flag
- End-of-byte transmission flag
- Transfer problem detection

I²C Master Features:

- Clock generation
- I²C bus busy flag
- Arbitration Lost Flag
- End of byte transmission flag
- Transmitter/Receiver Flag
- Start bit detection flag
- Start and Stop generation

I²C Slave Features:

- Stop bit detection
- I²C bus busy flag
- Detection of misplaced start or stop condition
- Programmable I²C Address detection
- Transfer problem detection
- End-of-byte transmission flag
- Transmitter/Receiver flag

10.7.3 General Description

In addition to receiving and transmitting data, this interface converts it from serial to parallel format

and vice versa, using either an interrupt or polled handshake. The interrupts are enabled or disabled by software. The interface is connected to the I²C bus by a data pin (SDAI) and by a clock pin (SCLI). It can be connected both with a standard I²C bus and a Fast I²C bus. This selection is made by software.

Mode Selection

The interface can operate in the four following modes:

- Slave transmitter/receiver
- Master transmitter/receiver

By default, it operates in slave mode.

The interface automatically switches from slave to master after it generates a START condition and from master to slave in case of arbitration loss or a STOP generation, allowing then Multi-Master capability.

Communication Flow

In Master mode, it initiates a data transfer and generates the clock signal. A serial data transfer always begins with a start condition and ends with a stop condition. Both start and stop conditions are generated in master mode by software.

In Slave mode, the interface is capable of recognising its own address (7 or 10-bit), and the General Call address. The General Call address detection may be enabled or disabled by software.

Data and addresses are transferred as 8-bit bytes, MSB first. The first byte(s) following the start condition contain the address (one in 7-bit mode, two in 10-bit mode). The address is always transmitted in Master mode.

A 9th clock pulse follows the 8 clock cycles of a byte transfer, during which the receiver must send an acknowledge bit to the transmitter. Refer to [Figure 64](#).

Figure 64. I²C BUS Protocol

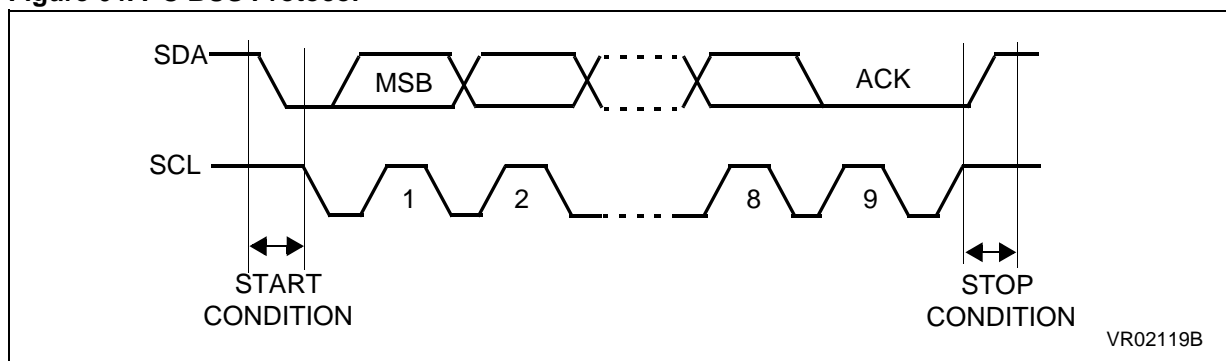

I²C BUS INTERFACE (Cont'd)

Acknowledge may be enabled and disabled by software.

The I²C interface address and/or general call address can be selected by software.

The speed of the I²C interface may be selected between Standard (up to 100KHz) and Fast I²C (up to 400KHz).

SDA/SCL Line Control

Transmitter mode: the interface holds the clock line low before transmission to wait for the microcontroller to write the byte in the Data Register.

Receiver mode: the interface holds the clock line low after reception to wait for the microcontroller to read the byte in the Data Register.

The SCL frequency (F_{SCL}) is controlled by a programmable clock divider which depends on the I²C bus mode.

When the I²C cell is enabled, the SDA and SCL ports must be configured as floating inputs. In this case, the value of the external pull-up resistor used depends on the application.

When the I²C cell is disabled, the SDA and SCL ports revert to being standard I/O port pins.

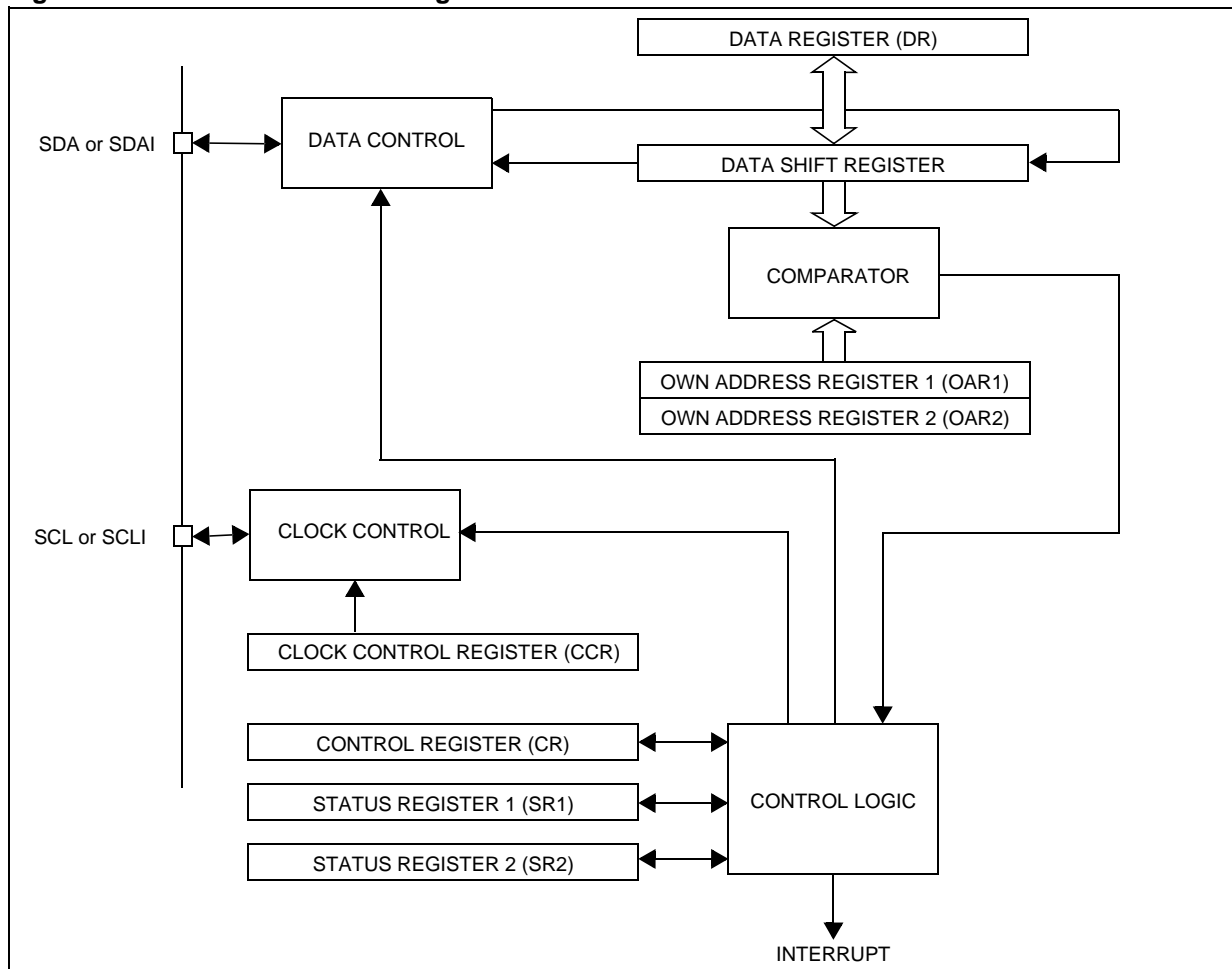
Figure 65. I²C Interface Block Diagram

I²C BUS INTERFACE (Cont'd)

10.7.4 Functional Description

Refer to the CR, SR1 and SR2 registers in [Section 10.7.7](#) for the bit definitions.

By default the I²C interface operates in Slave mode (M/SL bit is cleared) except when it initiates a transmit or receive sequence.

First the interface frequency must be configured using the FRi bits in the OAR2 register.

10.7.4.1 Slave Mode

As soon as a start condition is detected, the address is received from the SDA line and sent to the shift register; then it is compared with the address of the interface or the General Call address (if selected by software).

Note: In 10-bit addressing mode, the comparison includes the header sequence (11110xx0) and the two most significant bits of the address.

Header matched (10-bit mode only): the interface generates an acknowledge pulse if the ACK bit is set.

Address not matched: the interface ignores it and waits for another Start condition.

Address matched: the interface generates in sequence:

- Acknowledge pulse if the ACK bit is set.
- EVF and ADSL bits are set with an interrupt if the ITE bit is set.

Then the interface waits for a read of the SR1 register, **holding the SCL line low** (see [Figure 66](#) Transfer sequencing EV1).

Next, in 7-bit mode read the DR register to determine from the least significant bit (Data Direction Bit) if the slave must enter Receiver or Transmitter mode.

In 10-bit mode, after receiving the address sequence the slave is always in receive mode. It will enter transmit mode on receiving a repeated Start condition followed by the header sequence with matching address bits and the least significant bit set (11110xx1).

Slave Receiver

Following the address reception and after SR1 register has been read, the slave receives bytes from the SDA line into the DR register via the internal shift register. After each byte the interface generates in sequence:

- Acknowledge pulse if the ACK bit is set
- EVF and BTF bits are set with an interrupt if the ITE bit is set.

Then the interface waits for a read of the SR1 register followed by a read of the DR register, **holding the SCL line low** (see [Figure 66](#) Transfer sequencing EV2).

Slave Transmitter

Following the address reception and after SR1 register has been read, the slave sends bytes from the DR register to the SDA line via the internal shift register.

The slave waits for a read of the SR1 register followed by a write in the DR register, **holding the SCL line low** (see [Figure 66](#) Transfer sequencing EV3).

When the acknowledge pulse is received:

- The EVF and BTF bits are set by hardware with an interrupt if the ITE bit is set.

Closing slave communication

After the last data byte is transferred a Stop Condition is generated by the master. The interface detects this condition and sets:

- EVF and STOPF bits with an interrupt if the ITE bit is set.

Then the interface waits for a read of the SR2 register (see [Figure 66](#) Transfer sequencing EV4). Error Cases

- **BERR:** Detection of a Stop or a Start condition during a byte transfer. In this case, the EVF and the BERR bits are set with an interrupt if the ITE bit is set.

If it is a Stop then the interface discards the data, released the lines and waits for another Start condition.

If it is a Start then the interface discards the data and waits for the next slave address on the bus.

- **AF:** Detection of a non-acknowledge bit. In this case, the EVF and AF bits are set with an interrupt if the ITE bit is set.

The AF bit is cleared by reading the I2CSR2 register. However, if read before the completion of the transmission, the AF flag will be set again, thus possibly generating a new interrupt. Software must ensure either that the SCL line is back at 0 before reading the SR2 register, or be able to correctly handle a second interrupt during the 9th pulse of a transmitted byte.

Note: In case of errors, SCL line is not held low; however, the SDA line can remain low if the last bits transmitted are all 0. While AF=1, the SCL line may be held low due to SB or BTF flags that are set at the same time. It is then necessary to release both lines by software.

I²C INTERFACE (Cont'd)

How to release the SDA / SCL lines

Set and subsequently clear the STOP bit while BTF is set. The SDA/SCL lines are released after the transfer of the current byte.

SMBus Compatibility

ST7 I²C is compatible with SMBus V1.1 protocol. It supports all SMBus addressing modes, SMBus bus protocols and CRC-8 packet error checking. Refer to AN1713: SMBus Slave Driver For ST7 I²C Peripheral.

10.7.4.2 Master Mode

To switch from default Slave mode to Master mode a Start condition generation is needed.

Start condition

Setting the START bit while the BUSY bit is cleared causes the interface to switch to Master mode (M/SL bit set) and generates a Start condition.

Once the Start condition is sent:

- The EVF and SB bits are set by hardware with an interrupt if the ITE bit is set.

Then the master waits for a read of the SR1 register followed by a write in the DR register with the Slave address, **holding the SCL line low** (see [Figure 66](#) Transfer sequencing EV5).

Slave address transmission

Then the slave address is sent to the SDA line via the internal shift register.

In 7-bit addressing mode, one address byte is sent.

In 10-bit addressing mode, sending the first byte including the header sequence causes the following event:

- The EVF bit is set by hardware with interrupt generation if the ITE bit is set.

Then the master waits for a read of the SR1 register followed by a write in the DR register, **holding the SCL line low** (see [Figure 66](#) Transfer sequencing EV9).

Then the second address byte is sent by the interface.

After completion of this transfer (and acknowledge from the slave if the ACK bit is set):

- The EVF bit is set by hardware with interrupt generation if the ITE bit is set.

Then the master waits for a read of the SR1 register followed by a write in the CR register (for example set PE bit), **holding the SCL line low** (see [Figure 66](#) Transfer sequencing EV6).

Next the master must enter Receiver or Transmitter mode.

Note: In 10-bit addressing mode, to switch the master to Receiver mode, software must generate a repeated Start condition and resend the header sequence with the least significant bit set (11110xx1).

Master Receiver

Following the address transmission and after SR1 and CR registers have been accessed, the master receives bytes from the SDA line into the DR register via the internal shift register. After each byte the interface generates in sequence:

- Acknowledge pulse if the ACK bit is set
- EVF and BTF bits are set by hardware with an interrupt if the ITE bit is set.

Then the interface waits for a read of the SR1 register followed by a read of the DR register, **holding the SCL line low** (see [Figure 66](#) Transfer sequencing EV7).

To close the communication: before reading the last byte from the DR register, set the STOP bit to generate the Stop condition. The interface goes automatically back to slave mode (M/SL bit cleared).

Note: In order to generate the non-acknowledge pulse after the last received data byte, the ACK bit must be cleared just before reading the second last data byte.

I²C BUS INTERFACE (Cont'd)**Master Transmitter**

Following the address transmission and after SR1 register has been read, the master sends bytes from the DR register to the SDA line via the internal shift register.

The master waits for a read of the SR1 register followed by a write in the DR register, **holding the SCL line low** (see Figure 66 Transfer sequencing EV8).

When the acknowledge bit is received, the interface sets:

- EVF and BTF bits with an interrupt if the ITE bit is set.

To close the communication: after writing the last byte to the DR register, set the STOP bit to generate the Stop condition. The interface goes automatically back to slave mode (M/SL bit cleared).

Error Cases

- **BERR**: Detection of a Stop or a Start condition during a byte transfer. In this case, the EVF and BERR bits are set by hardware with an interrupt if ITE is set.

Note that BERR will not be set if an error is detected during the first or second pulse of each 9-bit transaction:

Single Master Mode

If a Start or Stop is issued during the first or second pulse of a 9-bit transaction, the BERR flag will not be set and transfer will continue however the BUSY flag will be reset. To work around this, slave devices should issue a NACK when they receive a misplaced Start or Stop. The reception of a NACK or BUSY by the master in the middle

of communication gives the possibility to reinitiate transmission.

Multimaster Mode

Normally the BERR bit would be set whenever unauthorized transmission takes place while transfer is already in progress. However, an issue will arise if an external master generates an unauthorized Start or Stop while the I²C master is on the first or second pulse of a 9-bit transaction. It is possible to work around this by polling the BUSY bit during I²C master mode transmission. The resetting of the BUSY bit can then be handled in a similar manner as the BERR flag being set.

- **AF**: Detection of a non-acknowledge bit. In this case, the EVF and AF bits are set by hardware with an interrupt if the ITE bit is set. To resume, set the Start or Stop bit.
The AF bit is cleared by reading the I2CSR2 register. However, if read before the completion of the transmission, the AF flag will be set again, thus possibly generating a new interrupt. Software must ensure either that the SCL line is back at 0 before reading the SR2 register, or be able to correctly handle a second interrupt during the 9th pulse of a transmitted byte.
- **ARLO**: Detection of an arbitration lost condition. In this case the ARLO bit is set by hardware (with an interrupt if the ITE bit is set and the interface goes automatically back to slave mode (the M/SL bit is cleared).

Note: In all these cases, the SCL line is not held low; however, the SDA line can remain low due to possible «0» bits transmitted last. It is then necessary to release both lines by software.

I²C BUS INTERFACE (Cont'd)

Figure 66. Transfer Sequencing

7-bit Slave receiver:

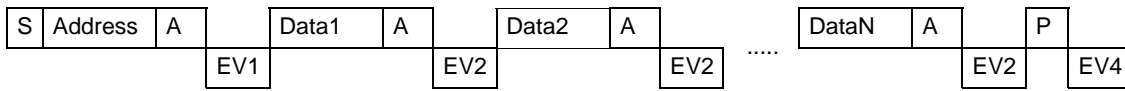

7-bit Slave transmitter:

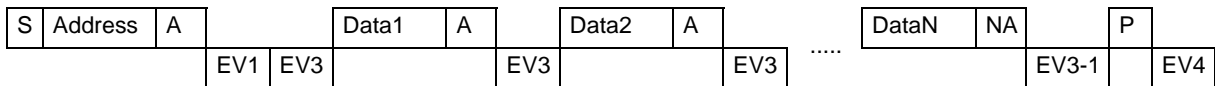

7-bit Master receiver:

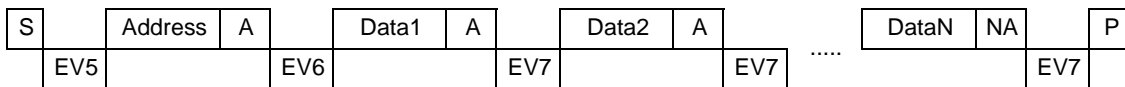

7-bit Master transmitter:

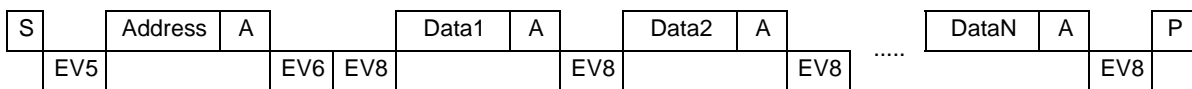

10-bit Slave receiver:

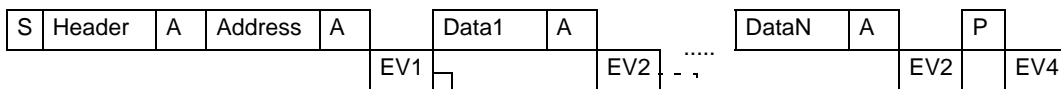

10-bit Slave transmitter:

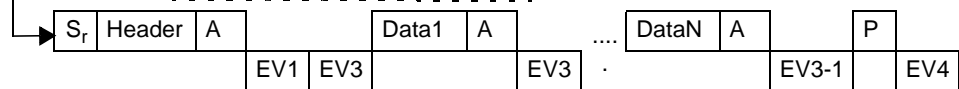

10-bit Master transmitter

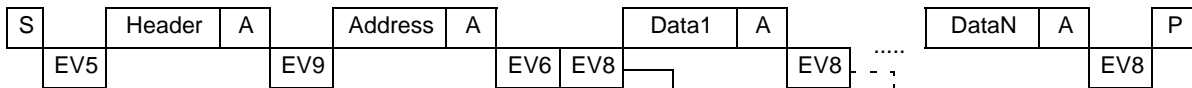

10-bit Master receiver:

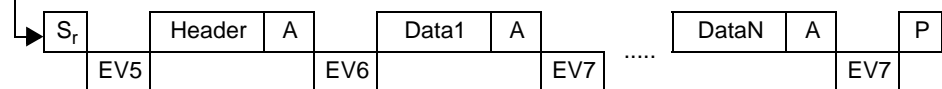

Legend: S=Start, Sr = Repeated Start, P=Stop, A=Acknowledge, NA=Non-acknowledge, EVx=Event (with interrupt if ITE=1)

EV1: EVF=1, ADSL=1, cleared by reading SR1 register.

EV2: EVF=1, BTF=1, cleared by reading SR1 register followed by reading DR register.

EV3: EVF=1, BTF=1, cleared by reading SR1 register followed by writing DR register.

EV3-1: EVF=1, AF=1, BTF=1; AF is cleared by reading SR1 register. BTF is cleared by releasing the lines (STOP=1, STOP=0) or by writing DR register (DR=FFh). **Note:** If lines are released by STOP=1, STOP=0, the subsequent EV4 is not seen.

EV4: EVF=1, STOPF=1, cleared by reading SR2 register.

EV5: EVF=1, SB=1, cleared by reading SR1 register followed by writing DR register.

EV6: EVF=1, cleared by reading SR1 register followed by writing CR register (for example PE=1).

EV7: EVF=1, BTF=1, cleared by reading SR1 register followed by reading DR register.

EV8: EVF=1, BTF=1, cleared by reading SR1 register followed by writing DR register.

EV9: EVF=1, ADD10=1, cleared by reading SR1 register followed by writing DR register.

I²C BUS INTERFACE (Cont'd)

10.7.5 Low Power Modes

Mode	Description
WAIT	No effect on I ² C interface. I ² C interrupts cause the device to exit from WAIT mode.
HALT	I ² C registers are frozen. In HALT mode, the I ² C interface is inactive and does not acknowledge data on the bus. The I ² C interface resumes operation when the MCU is woken up by an interrupt with "exit from HALT mode" capability.

10.7.6 Interrupts

Figure 67. Event Flags and Interrupt Generation

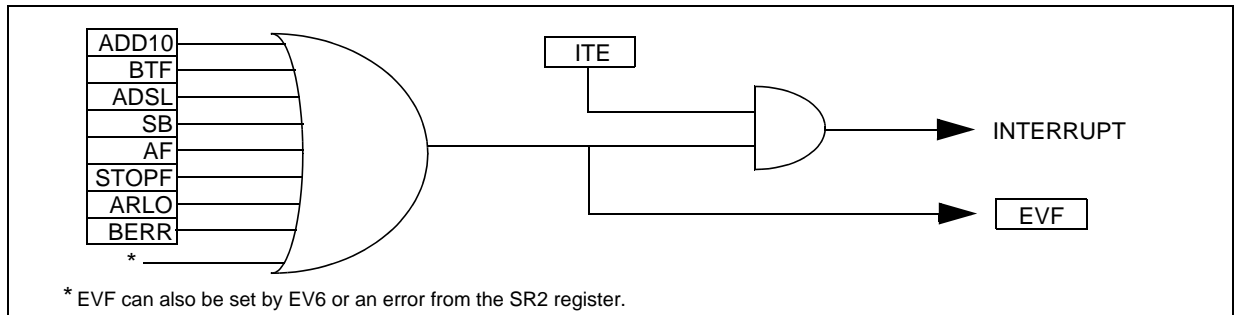

Interrupt Event	Event Flag	Enable Control Bit	Exit from Wait	Exit from Halt
10-bit Address Sent Event (Master mode)	ADD10	ITE	Yes	No
End of Byte Transfer Event	BTF		Yes	No
Address Matched Event (Slave mode)	ADSEL		Yes	No
Start Bit Generation Event (Master mode)	SB		Yes	No
Acknowledge Failure Event	AF		Yes	No
Stop Detection Event (Slave mode)	STOPF		Yes	No
Arbitration Lost Event (Multimaster configuration)	ARLO		Yes	No
Bus Error Event	BERR		Yes	No

Note: The I²C interrupt events are connected to the same interrupt vector (see Interrupts chapter). They generate an interrupt if the corresponding Enable Control Bit is set and the I-bit in the CC register is reset (RIM instruction).

I²C BUS INTERFACE (Cont'd)**10.7.7 Register Description****I²C CONTROL REGISTER (CR)**

Read / Write

Reset Value: 0000 0000 (00h)

7							0
0	0	PE	ENGC	START	ACK	STOP	ITE

Bit 7:6 = Reserved. Forced to 0 by hardware.

Bit 5 = **PE** *Peripheral enable*.

This bit is set and cleared by software.

0: Peripheral disabled

1: Master/Slave capability

Notes:

- When PE=0, all the bits of the CR register and the SR register except the Stop bit are reset. All outputs are released while PE=0
- When PE=1, the corresponding I/O pins are selected by hardware as alternate functions.
- To enable the I²C interface, write the CR register **TWICE** with PE=1 as the first write only activates the interface (only PE is set).

Bit 4 = **ENGC** *Enable General Call*.

This bit is set and cleared by software. It is also cleared by hardware when the interface is disabled (PE=0). The 00h General Call address is acknowledged (01h ignored).

0: General Call disabled

1: General Call enabled

Note: In accordance with the I2C standard, when GCAL addressing is enabled, an I2C slave can only receive data. It will not transmit data to the master.

Bit 3 = **START** *Generation of a Start condition*.

This bit is set and cleared by software. It is also cleared by hardware when the interface is disabled (PE=0) or when the Start condition is sent (with interrupt generation if ITE=1).

– In master mode:

0: No start generation

1: Repeated start generation

– In slave mode:

0: No start generation

1: Start generation when the bus is free

Bit 2 = **ACK** *Acknowledge enable*.

This bit is set and cleared by software. It is also cleared by hardware when the interface is disabled (PE=0).

0: No acknowledge returned

1: Acknowledge returned after an address byte or a data byte is received

Bit 1 = **STOP** *Generation of a Stop condition*.

This bit is set and cleared by software. It is also cleared by hardware in master mode. Note: This bit is not cleared when the interface is disabled (PE=0).

– In master mode:

0: No stop generation

1: Stop generation after the current byte transfer or after the current Start condition is sent. The STOP bit is cleared by hardware when the Stop condition is sent.

– In slave mode:

0: No stop generation

1: Release the SCL and SDA lines after the current byte transfer (BTF=1). In this mode the STOP bit has to be cleared by software.

Bit 0 = **ITE** *Interrupt enable*.

This bit is set and cleared by software and cleared by hardware when the interface is disabled (PE=0).

0: Interrupts disabled

1: Interrupts enabled

Refer to [Figure 67](#) for the relationship between the events and the interrupt.

SCL is held low when the ADD10, SB, BTF or ADSL flags or an EV6 event (See [Figure 66](#)) is detected.

I²C BUS INTERFACE (Cont'd)

I²C STATUS REGISTER 1 (SR1)

Read Only

Reset Value: 0000 0000 (00h)

7							0
EVF	ADD10	TRA	BUSY	BTF	ADSL	M/SL	SB

Bit 7 = **EVF** *Event flag*.

This bit is set by hardware as soon as an event occurs. It is cleared by software reading SR2 register in case of error event or as described in [Figure 66](#). It is also cleared by hardware when the interface is disabled (PE=0).

0: No event

1: One of the following events has occurred:

- BTF=1 (Byte received or transmitted)
- ADSL=1 (Address matched in Slave mode while ACK=1)
- SB=1 (Start condition generated in Master mode)
- AF=1 (No acknowledge received after byte transmission)
- STOPF=1 (Stop condition detected in Slave mode)
- ARLO=1 (Arbitration lost in Master mode)
- BERR=1 (Bus error, misplaced Start or Stop condition detected)
- ADD10=1 (Master has sent header byte)
- Address byte successfully transmitted in Master mode.

Bit 6 = **ADD10** *10-bit addressing in Master mode*.

This bit is set by hardware when the master has sent the first byte in 10-bit address mode. It is cleared by software reading SR2 register followed by a write in the DR register of the second address byte. It is also cleared by hardware when the peripheral is disabled (PE=0).

0: No ADD10 event occurred.

1: Master has sent first address byte (header)

Bit 5 = **TRA** *Transmitter/Receiver*.

When BTF is set, TRA=1 if a data byte has been transmitted. It is cleared automatically when BTF is cleared. It is also cleared by hardware after detection of Stop condition (STOPF=1), loss of bus arbitration (ARLO=1) or when the interface is disabled (PE=0).

0: Data byte received (if BTF=1)

1: Data byte transmitted

Bit 4 = **BUSY** *Bus busy*.

This bit is set by hardware on detection of a Start condition and cleared by hardware on detection of a Stop condition. It indicates a communication in progress on the bus. The BUSY flag of the I2CSR1 register is cleared if a Bus Error occurs.

0: No communication on the bus

1: Communication ongoing on the bus

Note:

- The BUSY flag is NOT updated when the interface is disabled (PE=0). This can have consequences when operating in Multimaster mode; i.e. a second active I²C master commencing a transfer with an unset BUSY bit can cause a conflict resulting in lost data. A software workaround consists of checking that the I²C is not busy before enabling the I²C Multimaster cell.

Bit 3 = **BTF** *Byte transfer finished*.

This bit is set by hardware as soon as a byte is correctly received or transmitted with interrupt generation if ITE=1. It is cleared by software reading SR1 register followed by a read or write of DR register. It is also cleared by hardware when the interface is disabled (PE=0).

- Following a byte transmission, this bit is set after reception of the acknowledge clock pulse. In case an address byte is sent, this bit is set only after the EV6 event (See [Figure 66](#)). BTF is cleared by reading SR1 register followed by writing the next byte in DR register.

- Following a byte reception, this bit is set after transmission of the acknowledge clock pulse if ACK=1. BTF is cleared by reading SR1 register followed by reading the byte from DR register.

The SCL line is held low while BTF=1.

0: Byte transfer not done

1: Byte transfer succeeded

Bit 2 = **ADSL** *Address matched (Slave mode)*.

This bit is set by hardware as soon as the received slave address matched with the OAR register content or a general call is recognized. An interrupt is generated if ITE=1. It is cleared by software reading SR1 register or by hardware when the interface is disabled (PE=0).

The SCL line is held low while ADSL=1.

0: Address mismatched or not received

1: Received address matched

I²C BUS INTERFACE (Cont'd)

Bit 1 = **M/SL Master/Slave**.

This bit is set by hardware as soon as the interface is in Master mode (writing START=1). It is cleared by hardware after detecting a Stop condition on the bus or a loss of arbitration (ARLO=1). It is also cleared when the interface is disabled (PE=0).

0: Slave mode
1: Master mode

Bit 0 = **SB Start bit (Master mode)**.

This bit is set by hardware as soon as the Start condition is generated (following a write START=1). An interrupt is generated if ITE=1. It is cleared by software reading SR1 register followed by writing the address byte in DR register. It is also cleared by hardware when the interface is disabled (PE=0).

0: No Start condition
1: Start condition generated

I²C STATUS REGISTER 2 (SR2)

Read Only

Reset Value: 0000 0000 (00h)

7							0
0	0	0	AF	STOPF	ARLO	BERR	GCAL

Bit 7:5 = Reserved. Forced to 0 by hardware.

Bit 4 = **AF Acknowledge failure**.

This bit is set by hardware when no acknowledge is returned. An interrupt is generated if ITE=1. It is cleared by software reading SR2 register or by hardware when the interface is disabled (PE=0).

The SCL line is not held low while AF=1 but by other flags (SB or BTF) that are set at the same time.

0: No acknowledge failure
1: Acknowledge failure

Note:

– When an AF event occurs, the SCL line is not held low; however, the SDA line can remain low if the last bits transmitted are all 0. It is then necessary to release both lines by software.

Bit 3 = **STOPF Stop detection (Slave mode)**.

This bit is set by hardware when a Stop condition is detected on the bus after an acknowledge (if ACK=1). An interrupt is generated if ITE=1. It is cleared by software reading SR2 register or by hardware when the interface is disabled (PE=0).

The SCL line is not held low while STOPF=1.

0: No Stop condition detected
1: Stop condition detected

Bit 2 = **ARLO Arbitration lost**.

This bit is set by hardware when the interface loses the arbitration of the bus to another master. An interrupt is generated if ITE=1. It is cleared by software reading SR2 register or by hardware when the interface is disabled (PE=0).

After an ARLO event the interface switches back automatically to Slave mode (M/SL=0).

The SCL line is not held low while ARLO=1.

0: No arbitration lost detected
1: Arbitration lost detected

Note:

– In a Multimaster environment, when the interface is configured in Master Receive mode it does not perform arbitration during the reception of the Acknowledge Bit. Mishandling of the ARLO bit from the I2CSR2 register may occur when a second master simultaneously requests the same data from the same slave and the I²C master does not acknowledge the data. The ARLO bit is then left at 0 instead of being set.

Bit 1 = **BERR Bus error**.

This bit is set by hardware when the interface detects a misplaced Start or Stop condition. An interrupt is generated if ITE=1. It is cleared by software reading SR2 register or by hardware when the interface is disabled (PE=0).

The SCL line is not held low while BERR=1.

0: No misplaced Start or Stop condition
1: Misplaced Start or Stop condition

Note:

– If a Bus Error occurs, a Stop or a repeated Start condition should be generated by the Master to re-synchronize communication, get the transmission acknowledged and the bus released for further communication

Bit 0 = **GCAL General Call (Slave mode)**.

This bit is set by hardware when a general call address is detected on the bus while ENGC=1. It is cleared by hardware detecting a Stop condition (STOPF=1) or when the interface is disabled (PE=0).

0: No general call address detected on bus
1: general call address detected on bus

I²C BUS INTERFACE (Cont'd)

I²C CLOCK CONTROL REGISTER (CCR)

Read / Write

Reset Value: 0000 0000 (00h)

7								0
FM/SM	CC6	CC5	CC4	CC3	CC2	CC1	CC0	

Bit 7 = **FM/SM** *Fast/Standard I²C mode*.
 This bit is set and cleared by software. It is not cleared when the interface is disabled (PE=0).
 0: Standard I²C mode
 1: Fast I²C mode

Bit 6:0 = **CC[6:0]** *7-bit clock divider*.
 These bits select the speed of the bus (F_{SCL}) depending on the I²C mode. They are not cleared when the interface is disabled (PE=0).
 Refer to the Electrical Characteristics section for the table of values.
 Note: The programmed F_{SCL} assumes no load on SCL and SDA lines.

I²C DATA REGISTER (DR)

Read / Write

Reset Value: 0000 0000 (00h)

7								0
D7	D6	D5	D4	D3	D2	D1	D0	

Bit 7:0 = **D[7:0]** *8-bit Data Register*.
 These bits contain the byte to be received or transmitted on the bus.

- Transmitter mode: Byte transmission start automatically when the software writes in the DR register.
- Receiver mode: the first data byte is received automatically in the DR register using the least significant bit of the address.
 Then, the following data bytes are received one by one after reading the DR register.

I²C BUS INTERFACE (Cont'd)

I²C OWN ADDRESS REGISTER (OAR1)

Read / Write

Reset Value: 0000 0000 (00h)

7							0
ADD7	ADD6	ADD5	ADD4	ADD3	ADD2	ADD1	ADD0

7-bit Addressing Mode

Bit 7:1 = **ADD[7:1]** *Interface address.*

These bits define the I²C bus address of the interface. They are not cleared when the interface is disabled (PE=0).

Bit 0 = **ADD0** *Address direction bit.*

This bit is don't care, the interface acknowledges either 0 or 1. It is not cleared when the interface is disabled (PE=0).

Note: Address 01h is always ignored.

10-bit Addressing Mode

Bit 7:0 = **ADD[7:0]** *Interface address.*

These are the least significant bits of the I²C bus address of the interface. They are not cleared when the interface is disabled (PE=0).

I²C OWN ADDRESS REGISTER (OAR2)

Read / Write

Reset Value: 0100 0000 (40h)

7							0
FR1	FR0	0	0	0	ADD9	ADD8	0

Bit 7:6 = **FR[1:0]** *Frequency bits.*

These bits are set by software only when the interface is disabled (PE=0). To configure the interface to I²C specified delays select the value corresponding to the microcontroller frequency F_{CPU}.

f _{CPU}	FR1	FR0
< 6 MHz	0	0
6 to 8 MHz	0	1

Bit 5:3 = Reserved

Bit 2:1 = **ADD[9:8]** *Interface address.*

These are the most significant bits of the I²C bus address of the interface (10-bit mode only). They are not cleared when the interface is disabled (PE=0).

Bit 0 = Reserved.

I²C BUS INTERFACE (Cont'd)

Table 23. I²C Register Map and Reset Values

Address (Hex.)	Register Label	7	6	5	4	3	2	1	0
0018h	I ² CCR Reset Value	0	0	PE 0	ENGC 0	START 0	ACK 0	STOP 0	ITE 0
0019h	I ² CSR1 Reset Value	EVF 0	ADD10 0	TRA 0	BUSY 0	BTF 0	ADSL 0	M/SL 0	SB 0
001Ah	I ² CSR2 Reset Value	0	0	0	AF 0	STOPF 0	ARLO 0	BERR 0	GCAL 0
001Bh	I ² CCCR Reset Value	FM/SM 0	CC6 0	CC5 0	CC4 0	CC3 0	CC2 0	CC1 0	CC0 0
001Ch	I ² COAR1 Reset Value	ADD7 0	ADD6 0	ADD5 0	ADD4 0	ADD3 0	ADD2 0	ADD1 0	ADD0 0
001Dh	I ² COAR2 Reset Value	FR1 0	FR0 1	0	0	0	ADD9 0	ADD8 0	0
001Eh	I ² CDR Reset Value	MSB 0	0	0	0	0	0	0	LSB 0

10.8 CONTROLLER AREA NETWORK (CAN)

10.8.1 Introduction

This peripheral is designed to support serial data exchanges using a multi-master contention based priority scheme as described in CAN specification Rev. 2.0 part A. It can also be connected to a 2.0 B network without problems, since extended frames

are checked for correctness and acknowledged accordingly although such frames cannot be transmitted nor received. The same applies to overload frames which are recognized but never initiated.

Figure 68. CAN Block Diagram

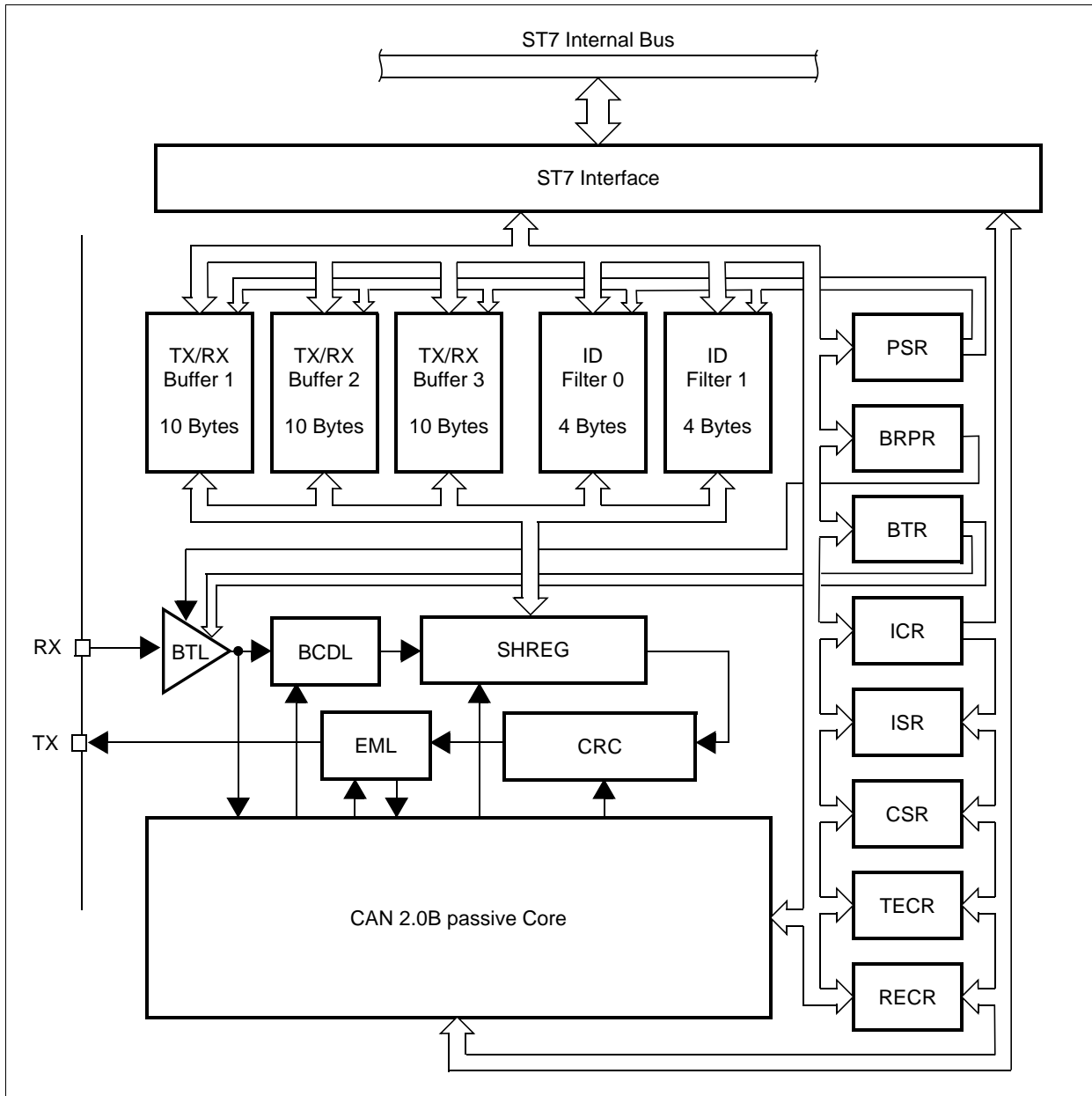

CONTROLLER AREA NETWORK (Cont'd)**10.8.2 Main Features**

- Support of CAN specification 2.0A and 2.0B passive
- Three prioritized 10-byte Transmit/Receive message buffers
- Two programmable global 12-bit message acceptance filters
- Programmable baud rates up to 1 MBit/s
- Buffer flip-flopping capability in transmission
- Maskable interrupts for transmit, receive (one per buffer), error and wake-up
- Automatic low-power mode after 20 recessive bits or on demand (standby mode)
- Interrupt-driven wake-up from standby mode upon reception of dominant pulse
- Optional dominant pulse transmission on leaving standby mode
- Automatic message queuing for transmission upon writing of data byte 7
- Programmable loop-back mode for self-test operation
- Advanced error detection and diagnosis functions
- Software-efficient buffer mapping at a unique address space
- Scalable architecture.

10.8.3 Functional Description**10.8.3.1 Frame Formats**

A summary of all the CAN frame formats is given in [Figure 69](#) for reference. It covers only the standard frame format since the extended one is only acknowledged.

A message begins with a start bit called Start Of Frame (SOF). This bit is followed by the arbitration field which contains the 11-bit identifier (ID) and the Remote Transmission Request bit (RTR). The RTR bit indicates whether it is a data frame or a remote request frame. A remote request frame does not have any data byte.

The control field contains the Identifier Extension bit (IDE), which indicates standard or extended format, a reserved bit (ro) and, in the last four bits, a count of the data bytes (DLC). The data field ranges from zero to eight bytes and is followed by the Cyclic Redundancy Check (CRC) used as a frame integrity check for detecting bit errors.

The acknowledgement (ACK) field comprises the ACK slot and the ACK delimiter. The bit in the ACK slot is placed on the bus by the transmitter as a recessive bit (logical 1). It is overwritten as a dominant bit (logical 0) by those receivers which have at this time received the data correctly. In this way, the transmitting node can be assured that at least one receiver has correctly received its message. Note that messages are acknowledged by the receivers regardless of the outcome of the acceptance test.

The end of the message is indicated by the End Of Frame (EOF). The intermission field defines the minimum number of bit periods separating consecutive messages. If there is no subsequent bus access by any station, the bus remains idle.

10.8.3.2 Hardware Blocks

The CAN controller contains the following functional blocks (refer to [Figure 68](#)):

- ST7 Interface: buffering of the ST7 internal bus and address decoding of the CAN registers.
- TX/RX Buffers: three 10-byte buffers for transmission and reception of maximum length messages.
- ID Filters: two 12-bit compare and don't care masks for message acceptance filtering.
- PSR: page selection register (see memory map).
- BRPR: clock divider for different data rates.
- BTR: bit timing register.
- ICR: interrupt control register.
- ISR: interrupt status register.
- CSR: general purpose control/status register.
- TECR: transmit error counter register.
- RECR: receive error counter register.
- BTL: bit timing logic providing programmable bit sampling and bit clock generation for synchronization of the controller.
- BCDL: bit coding logic generating a NRZ-coded datastream with stuff bits.
- SHREG: 8-bit shift register for serialization of data to be transmitted and parallelisation of received data.
- CRC: 15-bit CRC calculator and checker.
- EML: error detection and management logic.
- CAN Core: CAN 2.0B passive protocol controller.

CONTROLLER AREA NETWORK (Cont'd)

Figure 69. CAN Frames

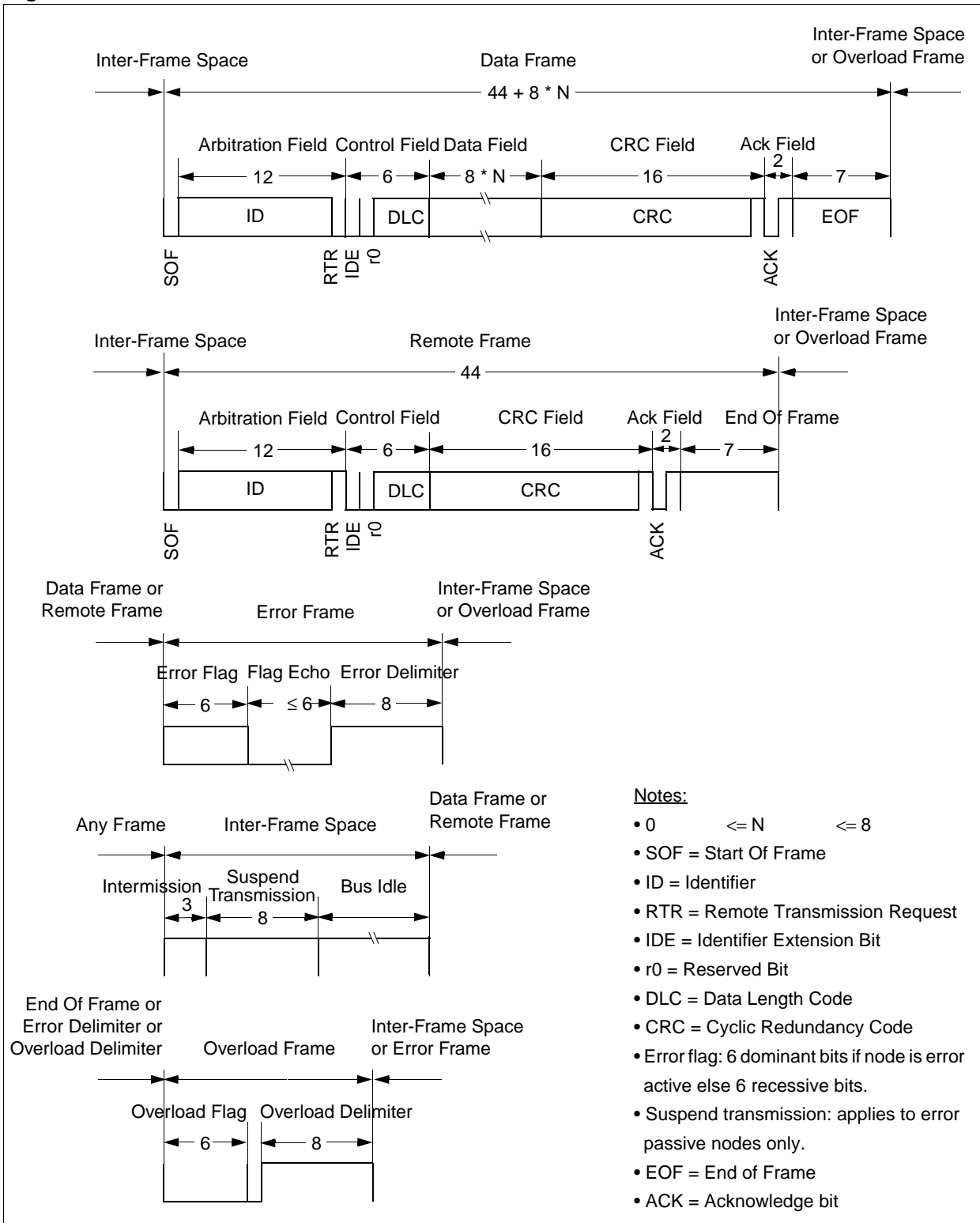

CONTROLLER AREA NETWORK (Cont'd)

10.8.3.3 Modes of Operation

The CAN Core unit assumes one of the seven states described below:

- **STANDBY.** Standby mode is entered either on a chip reset or on resetting the RUN bit in the Control/Status Register (CSR). Any on-going transmission or reception operation is not interrupted and completes normally before the Bit Time Logic and the clock prescaler are turned off for minimum power consumption. This state is signalled by the RUN bit being read-back as 0. Once in standby, the only event monitored is the reception of a dominant bit which causes a wake-up interrupt if the SCIE bit of the Interrupt Control Register (ICR) is set. The STANDBY mode is left by setting the RUN

bit. If the WKPS bit is set in the CSR register, then the controller passes through WAKE-UP otherwise it enters RESYNC directly. It is important to note that the wake-up mechanism is software-driven and therefore carries a significant time overhead. All messages received after the wake-up bit and before the controller is set to run and has completed synchronization are ignored.

Note: Standby mode is not entered on resetting the RUN bit in the Control/Status register (CSR) if the CANRX pin is shorted to GND.

- **WAKE-UP.** The CAN bus line is forced to dominant for one bit time signalling the wake-up condition to all other bus members.

Figure 70. CAN Controller State Diagram

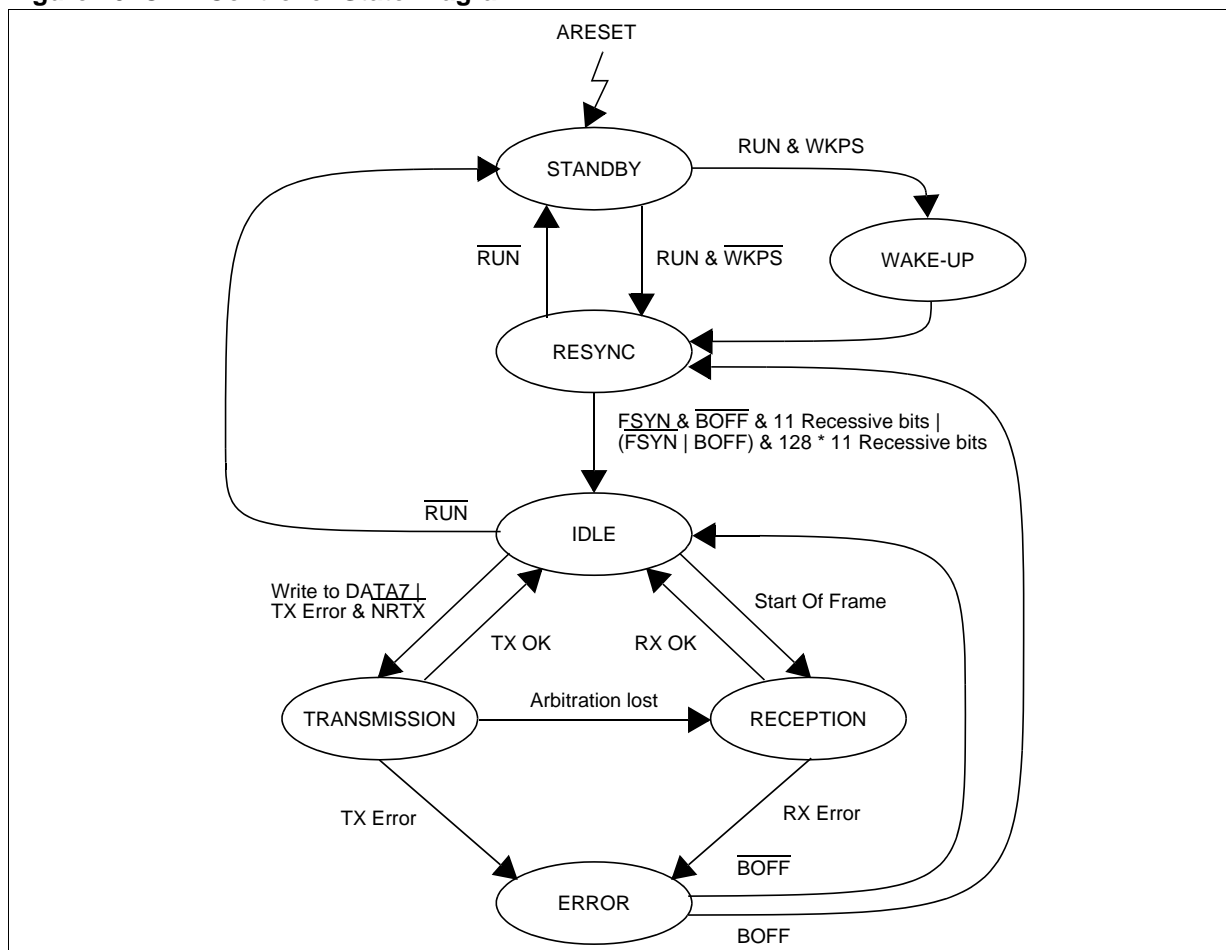

CONTROLLER AREA NETWORK (Cont'd)

- **RESYNC.** The resynchronization mode is used to find the correct entry point for starting transmission or reception after the node has gone asynchronous either by going into the STANDBY or bus-off states.
Resynchronization is achieved when 128 sequences of 11 recessive bits have been monitored unless the node is not bus-off and the FSYN bit in the CSR register is set in which case a single sequence of 11 recessive bits needs to be monitored.
- **IDLE.** The CAN controller looks for one of the following events: the RUN bit is reset, a Start Of Frame appears on the CAN bus or the DATA7 register of the currently active page is written to.
- **TRANSMISSION.** Once the LOCK bit of a Buffer Control/Status Register (BCSRx) has been set and read back as such, a transmit job can be submitted by writing to the DATA7 register. The message with the highest priority will be transmitted as soon as the CAN bus becomes idle. Among those messages with a pending transmission request, the highest priority is given to Buffer 3 then 2 and 1. If the transmission fails due to a lost arbitration or to an error while the NRTX bit of the CSR register is reset, then a new transmission attempt is performed. This goes on until the transmission ends successfully or until the job is cancelled by unlocking the buffer, by setting the NRTX bit or if the node ever enters bus-off or if a higher priority message becomes pending. The RDY bit in the BCSRx register, which was set since the job was submitted, gets reset. When a transmission is in progress, the BUSY bit in the BCSRx register is set. If it ends successfully then the TXIF bit in the Interrupt Status Register (ISR) is set, else the TEIF bit is set. An interrupt is generated in either case provided the TXIE and TEIE bits of the ICR register are set.
Note 1: Setting the SRTE bit of the CSR register

allows transmitted messages to be simultaneously received when they pass the acceptance filtering. This is particularly useful for checking the integrity of the communication path.

RECEPTION. Once the CAN controller has synchronized itself onto the bus activity, it is ready for reception of new messages. Every incoming message gets its identifier compared to the acceptance filters. If the bitwise comparison of the selected bits ends up with a match for at least one of the filters then that message is elected for reception and a target buffer is searched for. This buffer will be the first one - order is 1 to 3 - that has the LOCK and RDY bits of its BCSRx register reset.

- When no such buffer exists then an overrun interrupt is generated if the ORIE bit of the ICR register has been set. In this case the identifier of the last message is made available in the Last Identifier Register (LIDHR and LIDLRL) at least until it gets overwritten by a new identifier picked-up from the bus.
- When a buffer does exist, the accepted message gets written into it, the ACC bit in the BCSRx register gets the number of the matching filter, the RDY and RXIF bits get set and an interrupt is generated if the RXIE bit in the ISR register is set.

Up to three messages can be automatically received without intervention from the CPU because each buffer has its own set of status bits, greatly reducing the reactivity requirements in the processing of the receive interrupts.

CONTROLLER AREA NETWORK (Cont'd)

– **ERROR.** The error management as described in the CAN protocol is completely handled by hardware using 2 error counters which get incremented or decremented according to the error condition. Both of them may be read by the appli-

cation to determine the stability of the network. Moreover, as one of the node status bits (EPSV or BOFF of the CSR register) changes, an interrupt is generated if the SCIE bit is set in the ICR Register. Refer to [Figure 71](#).

Figure 71. CAN Error State Diagram

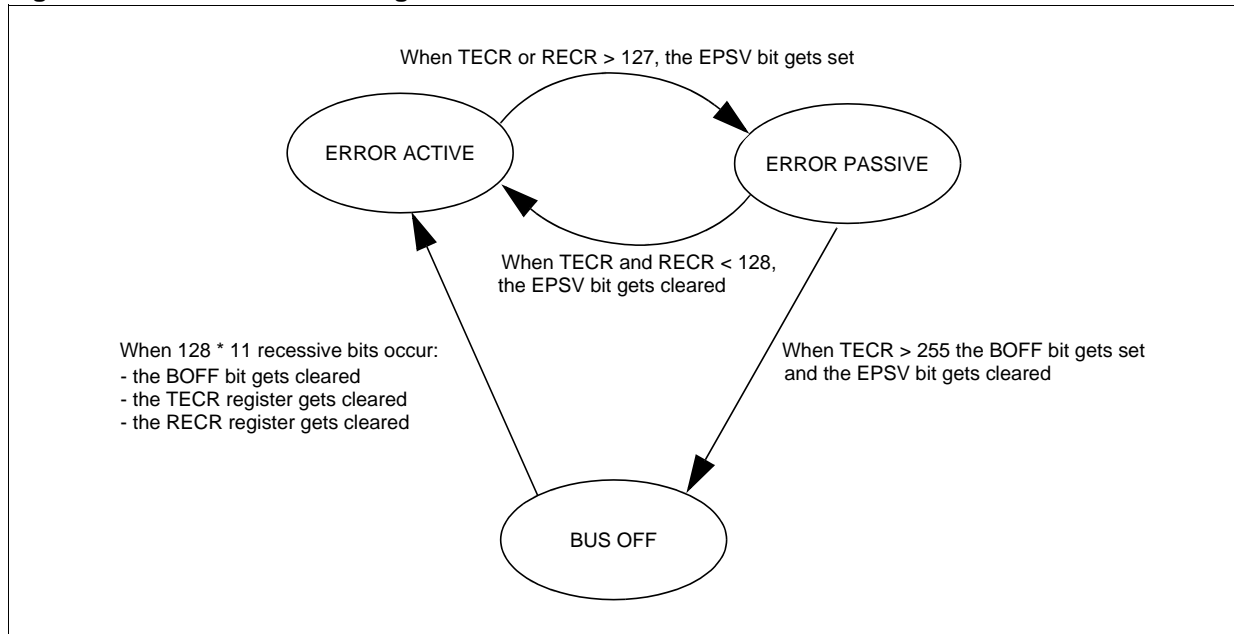

CONTROLLER AREA NETWORK (Cont'd)

10.8.3.4 Bit Timing Logic

The bit timing logic monitors the serial bus-line and performs sampling and adjustment of the sample point by synchronizing on the start-bit edge and re-synchronizing on following edges.

Its operation may be explained simply when the nominal bit time is divided into three segments as follows:

- **Synchronisation segment (SYNC_SEG):** a bit change is expected to lie within this time segment. It has a fixed length of one time quanta ($1 \times t_{CAN}$).
- **Bit segment 1 (BS1):** defines the location of the sample point. It includes the PROP_SEG and PHASE_SEG1 of the CAN standard. Its duration is programmable between 1 and 16 time quanta but may be automatically lengthened to compensate for positive phase drifts due to differences in the frequency of the various nodes of the network.
- **Bit segment 2 (BS2):** defines the location of the transmit point. It represents the PHASE_SEG2 of the CAN standard. Its duration is programmable between 1 and 8 time quanta but may also be automatically shortened to compensate for negative phase drifts.

- **Resynchronization Jump Width (RJW):** defines an upper bound to the amount of lengthening or shortening of the bit segments. It is programmable between 1 and 4 time quanta.

To guarantee the correct behaviour of the CAN controller, $SYNC_SEG + BS1 + BS2$ must be greater than or equal to 5 time quanta.

The CAN controller resynchronizes on recessive to dominant edges only.

For a detailed description of the CAN resynchronization mechanism and other bit timing configuration constraints, please refer to the Bosch CAN standard 2.0.

As a safeguard against programming errors, the configuration of the Bit Timing Register (BTR) is only possible while the device is in STANDBY mode.

Figure 72. Bit Timing

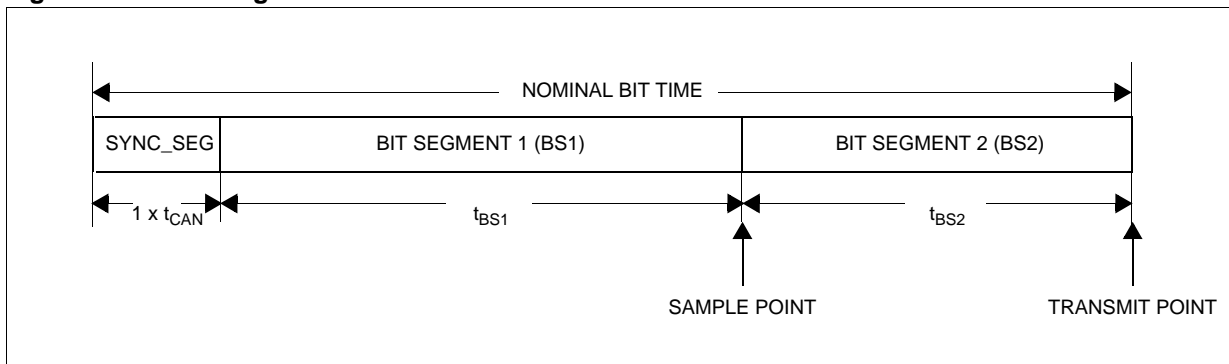

CONTROLLER AREA NETWORK (Cont'd)

10.8.4 Register Description

The CAN registers are organized as 6 general purpose registers plus 5 pages of 16 registers spanning the same address space and primarily used for message and filter storage. The page actually selected is defined by the content of the Page Selection Register.

10.8.4.1 General Purpose Registers

INTERRUPT STATUS REGISTER (ISR)

Read/Write

Reset Value: 00h

7								0
RXIF3	RXIF2	RXIF1	TXIF	SCIF	ORIF	TEIF	EPND	

Bit 7 = **RXIF3** *Receive Interrupt Flag for Buffer 3*
 — Read/Clear
 Set by hardware to signal that a new error-free message is available in buffer 3.
 Cleared by software to release buffer 3.
 Also cleared by resetting bit RDY of BCSR3.

Bit 6 = **RXIF2** *Receive Interrupt Flag for Buffer 2*
 — Read/Clear
 Set by hardware to signal that a new error-free message is available in buffer 2.
 Cleared by software to release buffer 2.
 Also cleared by resetting bit RDY of BCSR2.

Bit 5 = **RXIF1** *Receive Interrupt Flag for Buffer 1*
 — Read/Clear
 Set by hardware to signal that a new error-free message is available in buffer 1.
 Cleared by software to release buffer 1.
 Also cleared by resetting bit RDY of BCSR1.

Bit 4 = **TXIF** *Transmit Interrupt Flag*
 — Read/Clear
 Set by hardware to signal that the highest priority message queued for transmission has been successfully transmitted.
 Cleared by software.

Bit 3 = **SCIF** *Status Change Interrupt Flag*
 — Read/Clear
 Set by hardware to signal the reception of a dominant bit while in standby mode. In Run mode this bit is set when EPVS is set or reset (refer to [Figure 71. CAN Error State Diagram](#)). This bit also signals any receive error when ESCI=1.
 Cleared by software.

Bit 2 = **ORIF** *Overrun Interrupt Flag*
 — Read/Clear
 Set by hardware to signal that a message could not be stored because no receive buffer was available.
 Cleared by software.

Bit 1 = **TEIF** *Transmit Error Interrupt Flag*
 — Read/Clear
 Set by hardware to signal that an error occurred during the transmission of the highest priority message queued for transmission.
 Cleared by software.

Bit 0 = **EPND** *Error Interrupt Pending*
 — Read Only
 Set by hardware when at least one of the three error interrupt flags SCIF, ORIF or TEIF is set.
 Reset by hardware when all error interrupt flags have been cleared.

Caution:
 Interrupt flags are reset by writing a “0” to the corresponding bit position. The appropriate way consists in writing an immediate mask or the one’s complement of the register content initially read by the interrupt handler. Bit manipulation instruction BRES should never be used due to its read-modify-write nature.

CONTROLLER AREA NETWORK (Cont'd)**INTERRUPT CONTROL REGISTER (ICR)**

Read/Write

Reset Value: 00h

7							0
0	ESCI	RXIE	TXIE	SCIE	ORIE	TEIE	0

Bit 7 = Reserved.

Bit 6 = **ESCI** *Extended Status Change Interrupt*
— Read/Set/Clear

Set by software to specify that SCIF is to be set on receive errors also.

Cleared by software to set SCIF only on status changes and wake-up but not on all receive errors.

Bit 5 = **RXIE** *Receive Interrupt Enable*
— Read/Set/Clear

Set by software to enable an interrupt request whenever a message has been received free of errors.

Cleared by software to disable receive interrupt requests.

Bit 4 = **TXIE** *Transmit Interrupt Enable*
— Read/Set/Clear

Set by software to enable an interrupt request

whenever a message has been successfully transmitted.

Cleared by software to disable transmit interrupt requests.

Bit 3 = **SCIE** *Status Change Interrupt Enable*
— Read/Set/Clear

Set by software to enable an interrupt request whenever the node's status changes in run mode or whenever a dominant pulse is received in standby mode.

Cleared by software to disable status change interrupt requests.

Bit 2 = **ORIE** *Overrun Interrupt Enable*
— Read/Set/Clear

Set by software to enable an interrupt request whenever a message should be stored and no receive buffer is available.

Cleared by software to disable overrun interrupt requests.

Bit 1 = **TEIE** *Transmit Error Interrupt Enable*
— Read/Set/Clear

Set by software to enable an interrupt whenever an error has been detected during transmission of a message.

Cleared by software to disable transmit error interrupts.

Bit 0 = Reserved.

CONTROLLER AREA NETWORK (Cont'd)

CONTROL/STATUS REGISTER (CSR)

Read/Write

Reset Value: 00h

7								0
0	BOFF	EPSV	SRTE	NRTX	FSYN	WKPS	RUN	

Bit 6 = **BOFF** *Bus-Off State*
 — Read Only
 Set by hardware to indicate that the node is in bus-off state, i.e. the Transmit Error Counter exceeds 255.
 Reset by hardware to indicate that the node is involved in bus activities.

Bit 5 = **EPSV** *Error Passive State*
 — Read Only
 Set by hardware to indicate that the node is error passive.
 Reset by hardware to indicate that the node is either error active (BOFF = 0) or bus-off.

Bit 4 = **SRTE** *Simultaneous Receive/Transmit Enable* — Read/Set/Clear
 Set by software to enable simultaneous transmission and reception of a message passing the acceptance filtering. Allows to check the integrity of the communication path.
 Reset by software to discard all messages transmitted by the node. Allows remote and data frames to share the same identifier.

Bit 3 = **NRTX** *No Retransmission*
 — Read/Set/Clear
 Set by software to disable the retransmission of unsuccessful messages. It does not stop transmission in case of Arbitration Lost.
 Cleared by software to enable retransmission of messages until success is met.

Bit 2 = **FSYN** *Fast Synchronization*
 — Read/Set/Clear
 Set by software to enable a fast resynchronization when leaving standby mode, i.e. wait for only 11 recessive bits in a row.
 Cleared by software to enable the standard resynchronization when leaving standby mode, i.e. wait for 128 sequences of 11 recessive bits.

Bit 1 = **WKPS** *Wake-up Pulse*
 — Read/Set/Clear
 Set by software to generate a dominant pulse when leaving standby mode.
 Cleared by software for no dominant wake-up pulse.

Bit 0 = **RUN** *CAN Enable*
 — Read/Set/Clear
 Set by software to leave standby mode after 128 sequences of 11 recessive bits or just 11 recessive bits if FSYN is set.
 Cleared by software to request a switch to the standby or low-power mode as soon as any on-going transfer is complete. Read-back as 1 in the meantime to enable proper signalling of the standby state. The CPU clock may therefore be safely switched OFF whenever RUN is read as 0.

CONTROLLER AREA NETWORK (Cont'd)

BAUD RATE PRESCALER REGISTER (BRPR)

Read/Write in Standby mode

Reset Value: 00h

7								0
RJW1	RJW0	BRP5	BRP4	BRP3	BRP2	BRP1	BRP0	

RJW[1:0] determine the maximum number of time quanta by which a bit period may be shortened or lengthened to achieve resynchronization.

$$t_{RJW} = t_{CAN} * (RJW + 1)$$

BRP[5:0] determine the CAN system clock cycle time or time quanta which is used to build up the individual bit timing.

$$t_{CAN} = t_{CPU} * (BRP + 1)$$

Where t_{CPU} = time period of the CPU clock.

The resulting baud rate can be computed by the formula:

$$BR = \frac{1}{t_{CPU} \times (BRP + 1) \times (BS1 + BS2 + 3)}$$

Note: Writing to this register is allowed only in Standby mode to prevent any accidental CAN protocol violation through programming errors.

BIT TIMING REGISTER (BTR)

Read/Write in Standby mode

Reset Value: 23h

7							0
0	BS22	BS21	BS20	BS13	BS12	BS11	BS10

BS2[2:0] determine the length of Bit Segment 2.

$$t_{BS2} = t_{CAN} * (BS2 + 1)$$

BS1[3:0] determine the length of Bit Segment 1.

$$t_{BS1} = t_{CAN} * (BS1 + 1)$$

Note: Writing to this register is allowed only in Standby mode to prevent any accidental CAN protocol violation through programming errors.

PAGE SELECTION REGISTER (PSR)

Read/Write

Reset Value: 00h

7							0
0	0	0	0	0	PAGE 2	PAGE 1	PAGE 0

PAGE[2:0] determine which buffer or filter page is mapped at addresses 0010h to 001Fh.

PAGE2	PAGE1	PAGE0	Page Title
0	0	0	Diagnosis
0	0	1	Buffer 1
0	1	0	Buffer 2
0	1	1	Buffer 3
1	0	0	Filters
1	0	1	Reserved
1	1	0	Reserved
1	1	1	Reserved

CONTROLLER AREA NETWORK (Cont'd)

10.8.4.2 Paged Registers

LAST IDENTIFIER HIGH REGISTER (LIDHR)

Read/Write
Reset Value: Undefined

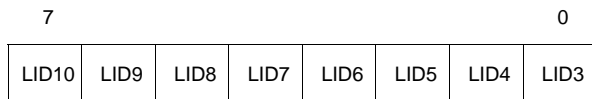

LID[10:3] are the most significant 8 bits of the last Identifier read on the CAN bus.

LAST IDENTIFIER LOW REGISTER (LIDLR)

Read/Write
Reset Value: Undefined

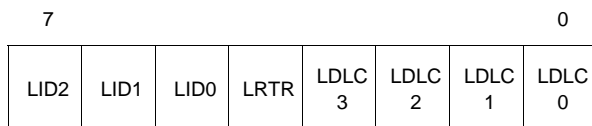

LID[2:0] are the least significant 3 bits of the last Identifier read on the CAN bus.

LRTR is the last Remote Transmission Request bit read on the CAN bus.

LDLC[3:0] is the last Data Length Code read on the CAN bus.

TRANSMIT ERROR COUNTER REG. (TECR)

Read Only
Reset Value: 00h

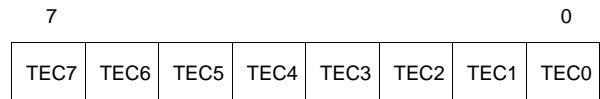

TEC[7:0] is the least significant byte of the 9-bit Transmit Error Counter implementing part of the fault confinement mechanism of the CAN protocol. In case of an error during transmission, this counter is incremented by 8. It is decremented by 1 after every successful transmission. When the counter value exceeds 127, the CAN controller enters the error passive state. When a value of 256 is reached, the CAN controller is disconnected from the bus.

RECEIVE ERROR COUNTER REG. (RECR)

Page: 00h — Read Only
Reset Value: 00h

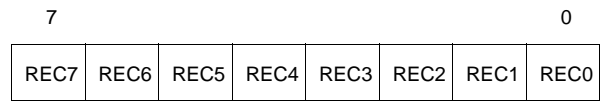

REC[7:0] is the Receive Error Counter implementing part of the fault confinement mechanism of the CAN protocol. In case of an error during reception, this counter is incremented by 1 or by 8 depending on the error condition as defined by the CAN standard. After every successful reception the counter is decremented by 1 or reset to 120 if its value was higher than 128. When the counter value exceeds 127, the CAN controller enters the error passive state.

IDENTIFIER HIGH REGISTERS (IDHRx)

Read/Write
Reset Value: Undefined

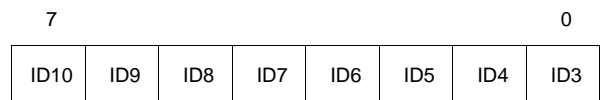

ID[10:3] are the most significant 8 bits of the 11-bit message identifier. The identifier acts as the message's name, used for bus access arbitration and acceptance filtering.

CONTROLLER AREA NETWORK (Cont'd)

IDENTIFIER LOW REGISTERS (IDLRx)

Read/Write
Reset Value: Undefined

7							0
ID2	ID1	ID0	RTR	DLC3	DLC2	DLC1	DLC0

ID[2:0] are the least significant 3 bits of the 11-bit message identifier.

RTR is the Remote Transmission Request bit. It is set to indicate a remote frame and reset to indicate a data frame.

DLC[3:0] is the Data Length Code. It gives the number of bytes in the data field of the message. The valid range is 0 to 8.

DATA REGISTERS (DATA0-7x)

Read/Write
Reset Value: Undefined

7							0
DATA 7	DATA 6	DATA 5	DATA 4	DATA 3	DATA 2	DATA 1	DATA 0

DATA[7:0] is a message data byte. Up to eight such bytes may be part of a message. Writing to byte DATA7 initiates a transmit request and should always be done even when DATA7 is not part of the message.

BUFFER CONTROL/STATUS REGs. (BCSRx)

Read/Write
Reset Value: 00h

7							0
0	0	0	0	ACC	RDY	BUSY	LOCK

Bit 3 = **ACC** *Acceptance Code*

— Read Only

Set by hardware with the id of the highest priority filter which accepted the message stored in the buffer.

ACC = 0: Match for Filter/Mask0. Possible match for Filter/Mask1.

ACC = 1: No match for Filter/Mask0 and match for Filter/Mask1.

Reset by hardware when either RDY or RXIF gets reset.

Bit 2 = **RDY** *Message Ready*

— Read/Clear

Set by hardware to signal that a new error-free message is available (LOCK = 0) or that a transmission request is pending (LOCK = 1).

Cleared by software when LOCK = 0 to release the buffer and to clear the corresponding RXIF bit in the Interrupt Status Register.

Cleared by hardware when LOCK = 1 to indicate that the transmission request has been serviced or cancelled.

Bit 1 = **BUSY** *Busy Buffer*

— Read Only

Set by hardware when the buffer is being filled (LOCK = 0) or emptied (LOCK = 1) and reset after the 2nd intermission bit.

Reset by hardware when the buffer is not accessed by the CAN core for transmission nor reception purposes.

Bit 0 = **LOCK** *Lock Buffer*

— Read/Set/Clear

Set by software to lock a buffer. No more message can be received into the buffer thus preserving its content and making it available for transmission.

Cleared by software to make the buffer available for reception. Cancels any pending transmission request.

Cleared by hardware once a message has been successfully transmitted provided the early transmit interrupt mode is on. Left untouched otherwise.

Note that in order to prevent any message corruption or loss of context, LOCK cannot be set nor reset while BUSY is set. Trying to do so will result in LOCK not changing state.

CONTROLLER AREA NETWORK (Cont'd)

FILTER HIGH REGISTERS (FHRx)

Read/Write
Reset Value: Undefined

7							0
FIL11	FIL10	FIL9	FIL8	FIL7	FIL6	FIL5	FIL4

FIL[11:3] are the most significant 8 bits of a 12-bit message filter. The acceptance filter is compared bit by bit with the identifier and the RTR bit of the incoming message. If there is a match for the set of bits specified by the acceptance mask then the message is stored in a receive buffer.

FILTER LOW REGISTERS (FLRx)

Read/Write
Reset Value: Undefined

7					0				0
FIL3	FIL2	FIL1	FIL0	0	0	0	0	0	

FIL[3:0] are the least significant 4 bits of a 12-bit message filter.

MASK HIGH REGISTERS (MHRx)

Read/Write
Reset Value: Undefined

7							0
MSK11	MSK10	MSK9	MSK8	MSK7	MSK6	MSK5	MSK4

MSK[11:3] are the most significant 8 bits of a 12-bit message mask. The acceptance mask defines which bits of the acceptance filter should match the identifier and the RTR bit of the incoming message.
MSK_i = 0: don't care.
MSK_i = 1: match required.

MASK LOW REGISTERS (MLRx)

Read/Write
Reset Value: Undefined

7					0				0
MSK3	MSK2	MSK1	MSK0	0	0	0	0		

MSK[3:0] are the least significant 4 bits of a 12-bit message mask.

CONTROLLER AREA NETWORK (Cont'd)

Figure 73. CAN Register Map

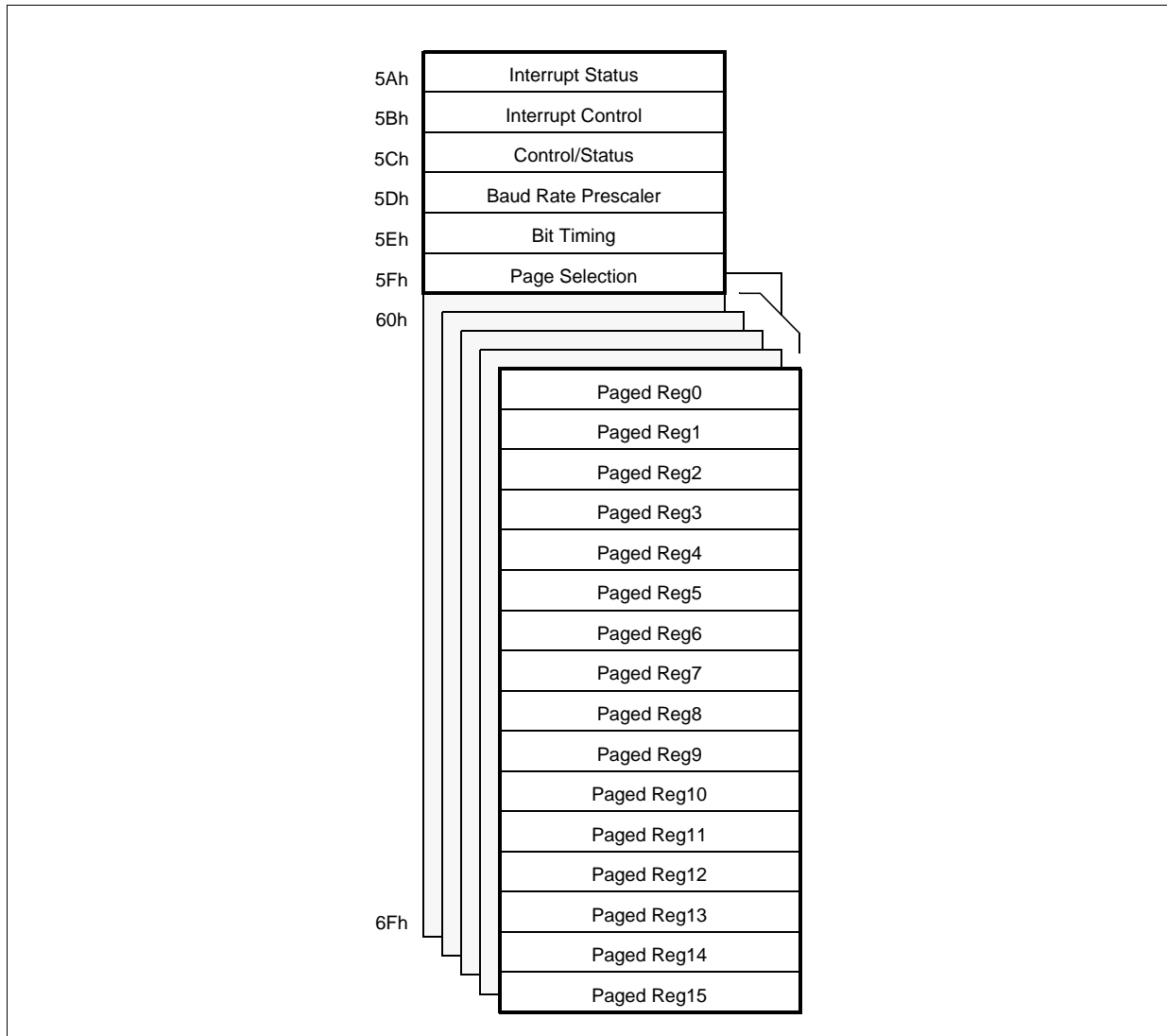

CONTROLLER AREA NETWORK (Cont'd)

Figure 74. Page Maps

	PAGE 0	PAGE 1	PAGE 2	PAGE 3	PAGE 4
60h	LIDHR	IDHR1	IDHR2	IDHR3	FHR0
61h	LIDLR	IDLR1	IDLR2	IDLR3	FLR0
62h	Reserved	DATA01	DATA02	DATA03	MHR0
63h		DATA11	DATA12	DATA13	MLR0
64h		DATA21	DATA22	DATA23	FHR1
65h		DATA31	DATA32	DATA33	FLR1
66h		DATA41	DATA42	DATA43	MHR1
67h		DATA51	DATA52	DATA53	MLR1
68h		DATA61	DATA62	DATA63	Reserved
69h		DATA71	DATA72	DATA73	
6Ah		Reserved	Reserved	Reserved	
6Bh					
6Ch					
6Dh					
6Eh	TECR	BCSR1	BCSR2	BCSR3	
6Fh	RECR				
	Diagnosis	Buffer 1	Buffer 2	Buffer 3	Acceptance Filters

CONTROLLER AREA NETWORK (Cont'd)

Table 24. CAN Register Map and Reset Values

Address (Hex.)	Page	Register Label	7	6	5	4	3	2	1	0
5A	X	CANISR Reset Value	RXIF3 0	RXIF2 0	RXIF1 0	TXIF 0	SCIF 0	ORIF 0	TEIF 0	EPND 0
5B		CANICR Reset Value	0	ESCI 0	RXIE 0	TXIE 0	SCIE 0	ORIE 0	TEIE 0	ETX 0
5C		CANCSR Reset Value	0	BOFF 0	EPSV 0	SRTE 0	NRTX 0	FSYN 0	WKPS 0	RUN 0
5D		CANBRPR Reset Value	RJW1 0	RJW0 0	BRP5 0	BRP4 0	BRP3 0	BRP2 0	BRP1 0	BRP0 0
5E		CANBTR Reset Value	0	BS22 0	BS21 1	BS20 0	BS13 0	BS12 0	BS11 1	BS10 1
5F		CANPSR Reset Value	0	0	0	0	0	PAGE2 0	PAGE1 0	PAGE0 0
60	0	CANLIDHR Reset Value	LID10 x	LID9 x	LID8 x	LID7 x	LID6 x	LID5 x	LID4 x	LID3 x
	1 to 3	CANIDHRx Reset Value	ID10 x	ID9 x	ID8 x	ID7 x	ID6 x	ID5 x	ID4 x	ID3 x
60, 64	4	CANFHRx Reset Value	FIL11 x	FIL10 x	FIL9 x	FIL8 x	FIL7 x	FIL6 x	FIL5 x	FIL4 x
61	0	CANLIDLR Reset Value	LID2 x	LID1 x	LID0 x	LRTR x	LDLC3 x	LDLC2 x	LDLC1 x	LDLC0 x
	1 to 3	CANIDLRx Reset Value	ID2 x	ID1 x	ID0 x	RTR x	DLC3 x	DLC2 x	DLC1 x	DLC0 x
61, 65	4	CANFLRx Reset Value	FIL3 x	FIL2 x	FIL1 x	FIL0 x	0	0	0	0
62 to 69	1 to 3	CANDRx Reset Value	MSB x	x	x	x	x	x	x	LSB x
62, 66	4	CANMHRx Reset Value	MSK11 x	MSK10 x	MSK9 x	MSK8 x	MSK7 x	MSK6 x	MSK5 x	MSK4 x
63, 67	4	CANMLRx Reset Value	MSK3 x	MSK2 x	MSK1 x	MSK0 x	0	0	0	0
6E	0	CANTECR Reset Value	MSB 0	0	0	0	0	0	0	LSB 0
6F		CANRECR Reset Value	MSB 0	0	0	0	0	0	0	LSB 0
	1 to 3	CANBCSRx Reset Value	0	0	0	0	ACC 0	RDY 0	BUSY 0	LOCK 0

CONTROLLER AREA NETWORK (Cont'd)

10.8.5 List of CAN Cell Limitations

10.8.5.1 Omitted SOF bit

Symptom:

Start of Frame (SOF) bit is omitted if transmission is requested in the last Intermission bit.

Test Case:

5.3.1 10-Kbit Stress Test

Details:

The IUT is requested to start transmission immediately after the completion of the previous transmission. The LT also starts its transmission and asserts the SOF bit just after the 3rd Intermission bit. The IUT also starts transmission but omits the SOF bit. The IUT wins the arbitration and continues the transmission. The frame is sent correctly.

Impact On The Application:

As this effect only occurs when the IUT detects a SOF bit on the CAN bus, the fact that it omits its own SOF bit has no impact on the communication.

10.8.5.2 CAN: CPU Write Access (More Than One Cycle) Corrupts CAN Frame

Symptoms:

For CAN received messages the identifier high byte or last data byte can be corrupted.

For CAN transmitted messages the 2nd data byte can be corrupted.

Details:

The CAN transmit and receive buffers are implemented as dual ported RAM. During the reception of a CAN frame the CAN core writes the received identifier and the data byte-by-byte in the corresponding buffer.

IF the CAN bit timing configuration is $t_{BS2} < 5$ time quanta

AND

IF concurrently with the pCAN, the CPU executes a write access to the dual ported RAM using an instruction with more than one cycle access, e.g. CLR, BSET, BRES

THEN the access conflict can lead to the corruption described in the symptoms paragraph above.

Impact On The Application:

Several CAN frames with erroneous data or identifier will be received/transmitted.

Software Workaround:

Program $t_{BS2} > 4$ time quanta or, when accessing the receive or transmit buffers, do not use the critical instructions which are:

BSET, BRES, CLR, CPL, DEC, INC, NEG, RLC, SLL, SRL, RRC, SRA, SWAP.

CONTROLLER AREA NETWORK (Cont'd)**10.8.5.3 Unexpected message transmission****Symptom:**

The previous message received by pCAN, even if this message did not pass the receive filter, will be retransmitted by pCAN with a correct identifier and DLC but with corrupted data. The data bytes will be a copy of the identifier bytes IDHR and IDLR in the following repetitive pattern:

DATA_0 = IDHR

DATA_1 = IDLR

DATA_2 = IDHR

DATA_3 = IDLR

etc.

DATA_7 = IDLR

If no message has been received before the problem occurs then identifier byte values are random but the data bytes are in the same repetitive pattern.

Details:

The buffers of the pCAN cell are configurable as receive or transmit buffers. By default, all buffers are configured in reception. To use a buffer to transmit a CAN message the application has to reserve this buffer for transmission by setting the LOCK bit in the BCSR register. So the buffer is then locked for any further reception and reserved for transmission.

Once a transmission has been requested by a write access to data byte 7 of the buffer the appli-

cation might need to abort this transmission request. To do so, the application can reset the LOCK bit in the BCSR register.

If the message is pending (RDY bit set) but not currently being transmitted, then clearing the LOCK bit will abort it immediately.

If the message is pending (RDY bit set) and currently being transmitted then the message will not be interrupted but the CAN core will wait until the end of this transmission attempt. Then software must clear the LOCK bit again to abort the transmission.

An unexpected transmission can occur:

IF the application resets the LOCK bit

WHILE the CAN core is preparing the transmission¹⁾ **AND** there is no other transmission pending in another buffer

THEN the LOCK bit is reset but the transmission is not stopped. Instead the content of the page 0 buffer will be transmitted.

Impact On The Application:

pCAN will echo some messages sent by other nodes. Identifier and DLC will be correct but data are corrupted as described previously.

Note 1: The preparation lasts two bit times just before SOF, this is the **critical window** during which the LOCK bit must not be reset by the application.

CONTROLLER AREA NETWORK (Cont'd)**Software Work-around - Devices with Hardware Fix (ST72F521 rev "R"):**

To implement a transmission abort under safe conditions, the LOCK bit must not be reset during the critical window (2 bit times). A new function has been implemented in the MCU allowing the application to synchronize the reset of the LOCK bit (abort request) with the reset of the TXRQST bit (internal signal) in the pCAN core.

The synchronization is done using the WKPS bit in the CANCSR register, the function of this bit has been modified and no more Wake-up Pulse (dominant bit) is sent on the CAN_TX signal when the WKPS bit is set. This means the functionality described in the datasheet is no longer applicable (see [Section 10.8.5.4](#)).

To abort the transmission, first the application sets the WKPS bit and polls it until it is set. The maximum time needed to set this bit is two CAN bit times. Once the application has read the WKPS bit as one, it can reset the LOCK bit to stop the current transmission.

The abort is completed when the LOCK bit is read back as zero by the application. Once the abort has been completed, the application must reset the WKPS bit to be able to transmit again. Of course the transmit buffer must be in LOCK state as usual before any transmission attempt.

The "C" code sequence below shows the software work-around using the WKPS bit.

```
CANCSR |= WKPS;      // Set WKPS bit
while(!(CANCSR & WKPS) );// Wait until WKPS bit is set
while(CANBCSR & LOCK)// Wait until abort has been confirmed
{
    CANBCSR &= ~LOCK;
}
CANCSR &= ~WKPS;     // Allow transmission again
CANBCSR |= LOCK;     //Alloc buffer for next transmission
```

CONTROLLER AREA NETWORK (Cont'd)**Software Work-around - Devices without Hardware Fix:**

To implement a transmission abort under safe conditions, any reset of the LOCK bit during the critical window (2 bit times) must be avoided. Two different cases have to be considered, either the pCAN enters standby mode after the abort, or the abort is performed and pCAN keeps running.

Abort followed by STANDBY mode (RUN=0)

In this case, aborting the pending transmissions can safely be done by first entering STANDBY mode and then releasing the transmit buffers. STANDBY mode is entered by resetting the RUN bit in the CSR register and once the current transmission attempt, even if it fails due to error or lost arbitration, has been performed, pCAN enters STANDBY mode (RUN=0). Once in STANDBY mode the application can abort all pending transmissions by resetting the corresponding LOCK bit.

Abort while staying in RUN mode (RUN=1)

Contrary to the STANDBY case described previously, in the RUN case the application has to handle the error or arbitration lost conditions. In case of transmission errors, causing the frame to be transmitted again and again, the application must set the NRTX bit in the CSR register. This will cause pCAN to abort the transmission at the end of the current attempt.

In case of arbitration lost, setting the NRTX bit does not abort the transmission, therefore the application must reset the LOCK bit to abort the transmission. To avoid resetting the LOCK bit during the critical time window, leading to the problem described at the start of this section, the application must monitor the BUSY bit in the BCSR register and reset the LOCK bit just after the falling edge of the BUSY bit. The time between the falling edge of the BUSY bit and the SOF of the next transmission attempt is in any case long enough to guarantee that the LOCK bit is reset before the critical time window.

The "C" code sequence below shows the software work-around for both the error and arbitration lost cases.

```

_asm("SIM\n");      // Mask interrupts
CANCSR |= NRTX;     // Set non automatic retransmission bit
while(!(CANBCSR & BUSY) &&// Wait till BUSY bit is set
      (CANBCSR & RDY) ); // or transmission done
while( CANBCSR & BUSY ); // Wait till BUSY bit is reset (falling edge)
if( CANBCSR & RDY )
{ // transmission still pending -> must be aborted
    CANBCSR &= ~LOCK; //Arbitration lost => cancel transmission safely
    while( CANBCSR & RDY );// Wait for unlock confirmed
    CANCSR &= ~NRTX;// Reset NRTX bit once abort sequence done
    _asm("RIM\n");
}
else
{ // No more abort required as RDY bit already reset
    CANCSR &= ~NRTX;// Reset NRTX bit once abort sequence done
    _asm("RIM\n"); // Enable interrupts
}

```

Figure 75. Work-around Flowchart

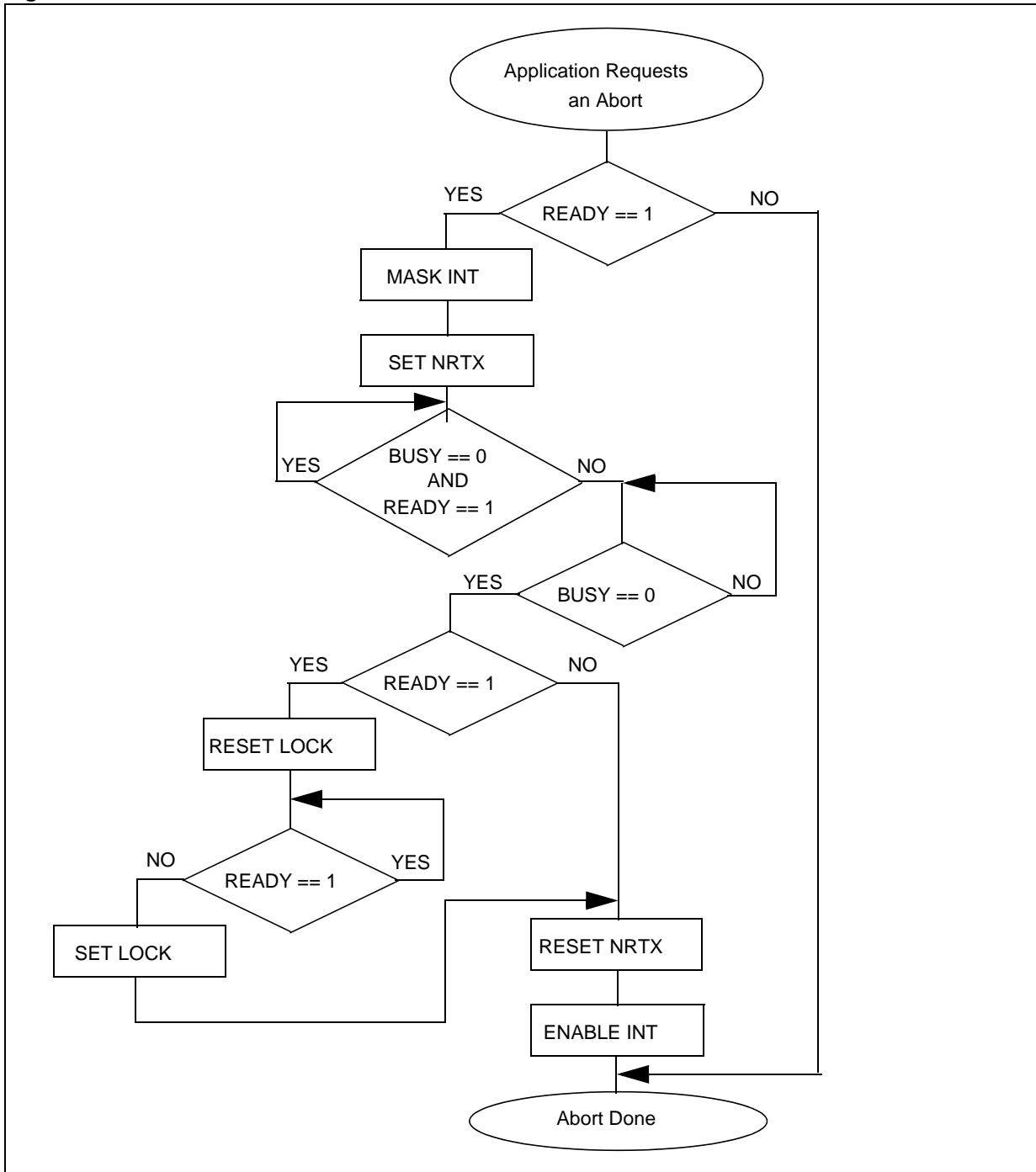

CONTROLLER AREA NETWORK (Cont'd)

The figures below show the abort behaviour in the four possible cases.

Figure 76. Abort and successful transmission

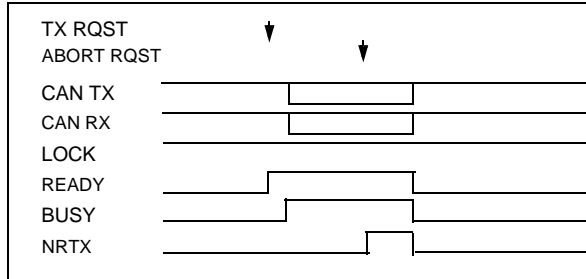

In this case the abort request performed during the transmission has no effect, as the first transmission is successful.

Figure 77. Abort and transmission delayed by busy CAN bus

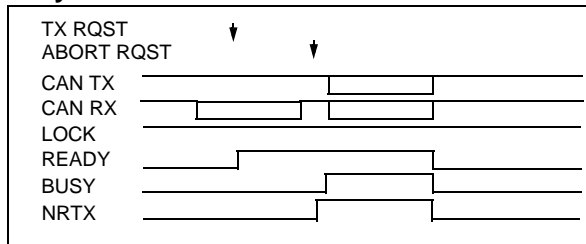

In this case the NRTX bit is set to abort the transmission after the first attempt. As the first attempt is successful the READY and BUSY bits are reset by pCAN and the transmit buffer becomes empty. An abort is no longer required.

Figure 78. Abort and error during transmission

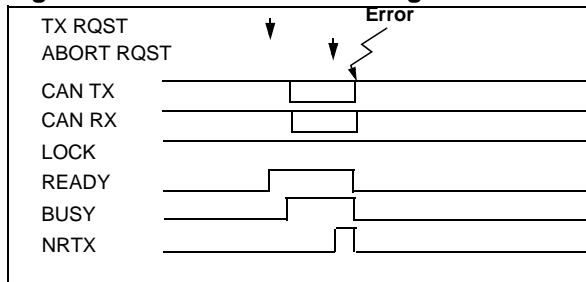

In this case NRTX (abort request) is set before the error, thus pCAN resets READY and BUSY after

the error (the first attempt). The abort has been successful and the transmit buffer is empty.

Figure 79. Abort and arbitration lost

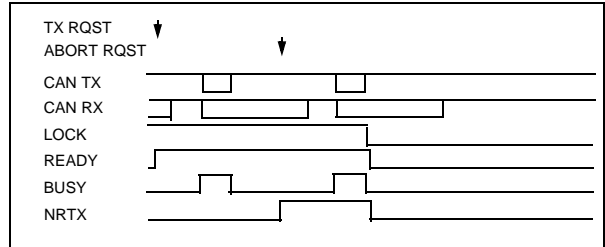

In this case the NRTX bit is set but has no effect, as the previous transmission attempt failed due to an arbitration lost. The application waits for the falling edge of BUSY bit and checks that READY is still set. This is the case, this means pCAN has lost the arbitration and LOCK bit can be safely reset. Abort is immediate and pCAN resets the READY and BUSY bits.

Timing Considerations

As no interrupt signals that an abort has been successful, the application has to wait until the transmit buffer is empty (transmission has been aborted or transmitted successfully). This time can vary depending on the case in which the abort is performed (arbitration lost, error or successful transmission). To show the impact of the software work-around on this timing behaviour [Figure 80](#) and [Figure 81](#) compare the reference behaviour (worst case when abort is done by LOCK only) with the behaviour when NRTX, BUSY and LOCK bits are used.

Figure 80. Abort by LOCK only - Reference behaviour

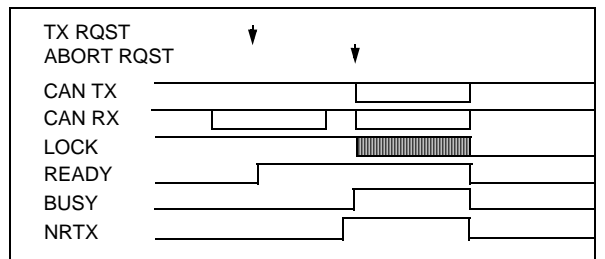

CONTROLLER AREA NETWORK (Cont'd)

The worst case is when the abort request is done when the transmission has just started. In this case the LOCK bit cannot be reset as long as the BUSY bit is set, this means until the end of the frame. So the application will wait for READY to be reset during the whole frame and in this case the worst case will be the longest frame the application is expected to transmit.

Figure 81. Abort with the software work-around - by NRTX, BUSY and LOCK

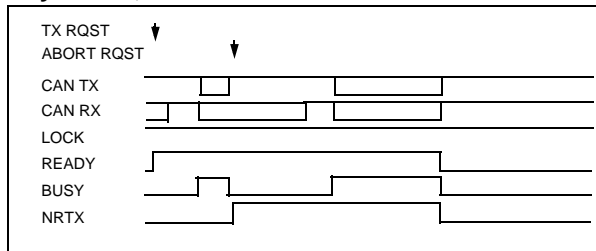

Using the software work-around the worst case occurs in the arbitration lost case. If the abort is requested just after pCAN has lost the arbitration then the application has to wait for the next falling edge of the BUSY bit before the LOCK bit can be

reset. If the next arbitration is won by pCAN then the BUSY bit will be reset by the end of the successful transmission. The longest time the application has to wait in this case is the time of the longest message expected on the bus (minus identifier) plus the longest message expected to be transmitted by the application. This roughly double the time the application may have to wait before the abort sequence is performed.

10.8.5.4 WKPS Functionality

Due to a fix implemented to solve the “Unexpected Message Transmission” issue (see [Section 10.8.5.3](#)) the WKPS functionality has been modified as follows in Flash ST72F521 devices:

Device	Modification
Flash ST72F521 Rev R	WKPS bit does not generate a wakeup pulse. It is used to synchronize the reset of the LOCK bit (see “Software Work-around - Devices with Hardware Fix (ST72F521 rev “R”):” on page 148)
ROM ST72521 All revisions	WKPS bit functions according to the datasheet description.

CONTROLLER AREA NETWORK (Cont'd)**10.8.5.5 Bus-off state not entered****Symptom:**

pCAN does not enter bus-off state under certain conditions. This is fixed in FLASH version of ST72F521 starting from silicon Rev R and in ROM version ST72521B starting from silicon Rev Y.

Details:

According to the CAN standard, pCAN is expected to enter bus-off state when TEC (Transmit Error Counter) is greater than 255.

But if REC (Receive Error Counter) is greater than 127 (Error Passive State) pCAN does not enter bus-off and the BOFF bit of the CSR register is not set. To enter bus-off, REC must decrease to a val-

ue lower than 128, this is the case with any correct reception even if the message is filtered out.

As bus-off state is not entered and pCAN still attempts to transmit its message, after the overflow the TEC register continues to increment as long as transmission errors occur.

Impact on the application:

The application will not stop attempting to transmit CAN messages, even when the bus-off conditions have been reached, until the transmission has been successful or the value of REC becomes lower than 128. However the application will not disturb the communication of the other nodes on the CAN network as pCAN is in Error Passive State.

Figure 82. CAN Error State Diagram showing “BUSOFF not entered” limitation

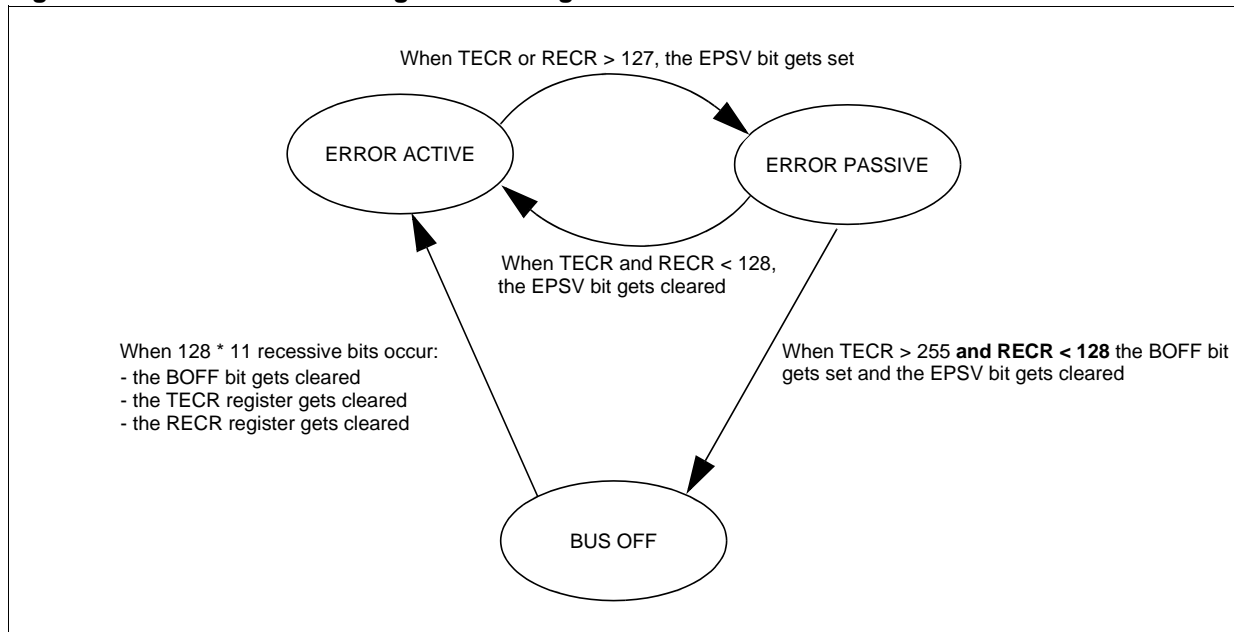

CONTROLLER AREA NETWORK (Cont'd)

Workaround Description

The bus-off entry works correctly in almost all cases, only when REC is greater than 127 a bus-off will not be recognized by pCAN. Therefore the pCAN bus-off signalling (BOFF) is still used but it needs to be complemented by monitoring TEC by software.

To detect the bus-off condition by software the application has to monitor the value of the TEC register periodically. An overflow signals a bus-off condition. When a bus-off condition has been detected the application must execute the following sequence to recover from bus-off properly: the application stops pCAN by clearing the RUN bit in the CANCSR register resets all pending transmission by clearing the LOCK bit in the BCSR register and starts it again by setting the RUN bit.

To detect the bus-off condition properly, the TEC monitoring period must be lower than the time between two overflows. As the problem only occurs when pCAN is in Error Passive State (REC > 127) pCAN will continuously try to send a SOF followed by an Error Passive Flag and a Suspend Transmission. This leads to 26 (1 + 6 + 8 + 3 + 8) bit times. Each time TEC is incremented by 8, hence

to reach 256 the sequence must be executed 32 times. Under these conditions the shortest sequence leading to a TEC overflow lasts 832 bit times.

Depending on the baudrate the application will have to adapt the monitoring period, for example at 500kbps the period must be less than 1600us.

The 'C' code below shows an implementation example of the monitoring sequence. This code is called periodically as described above.

To detect the overflow, the test condition must take into account that TEC might also have been decremented due to a successful transmission. So an overflow condition is detected:

IF the current TEC value is lower than the previous TEC value

AND the difference is greater than the number of possible successful transmissions during the monitoring period.

In the example above, one message can be sent, therefore one is added to CANTECR.

```

***** /
/* INITIALISATION
/***** /
unsigned char TECReg=0; //Previous value of TEC
unsigned char BusOffFlag=0; //Set to one if bus-off

/***** /
/* BUS-OFF MONITORING SEQUENCE
/***** /

if( (CANCSR & BOFF) || (CANTECR+1 < TECReg) )
{
    BusOffFlag = 1;
}
else
{
    TECReg = CANTECR;
}
    
```

10.9 10-BIT A/D CONVERTER (ADC)

10.9.1 Introduction

The on-chip Analog to Digital Converter (ADC) peripheral is a 10-bit, successive approximation converter with internal sample and hold circuitry. This peripheral has up to 16 multiplexed analog input channels (refer to device pin out description) that allow the peripheral to convert the analog voltage levels from up to 16 different sources.

The result of the conversion is stored in a 10-bit Data Register. The A/D converter is controlled through a Control/Status Register.

10.9.2 Main Features

- 10-bit conversion
- Up to 16 channels with multiplexed input
- Linear successive approximation
- Data register (DR) which contains the results
- Conversion complete status flag
- On/off bit (to reduce consumption)

The block diagram is shown in [Figure 83](#).

Figure 83. ADC Block Diagram

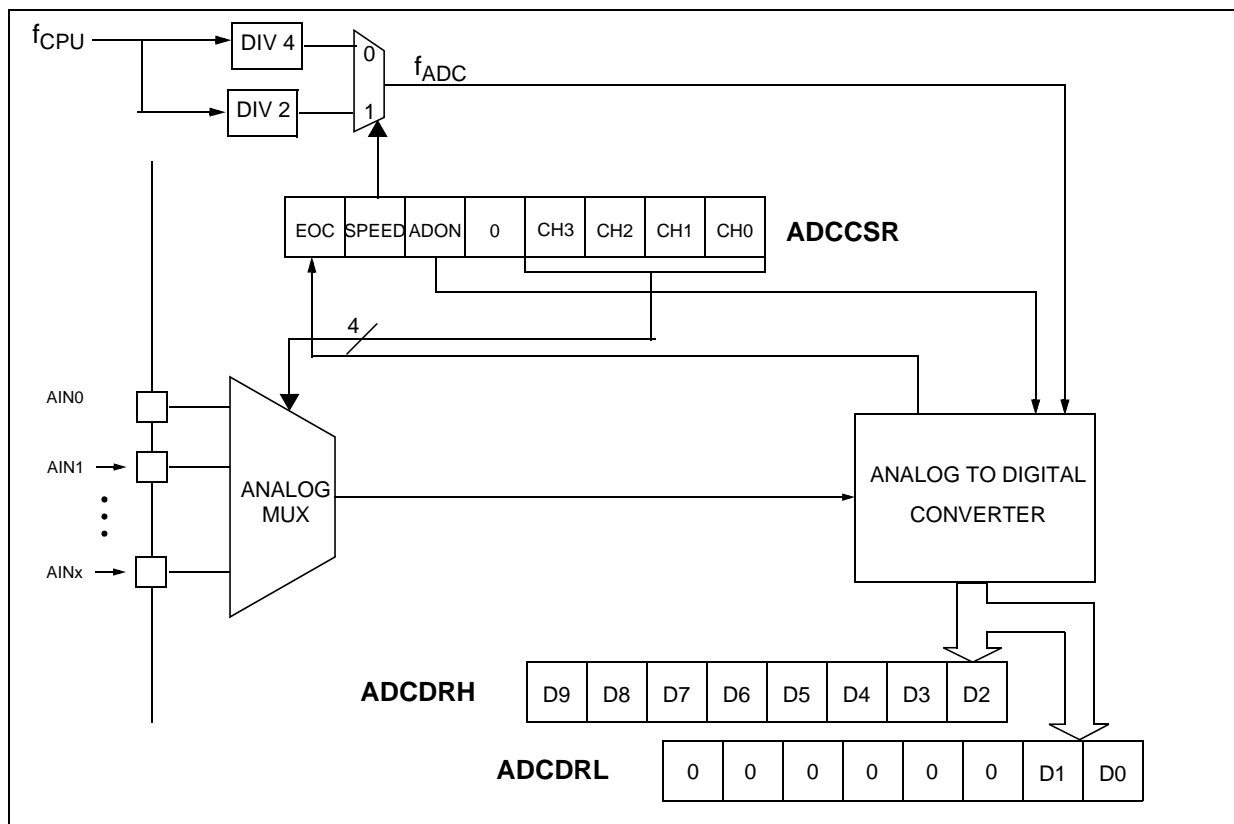

10-BIT A/D CONVERTER (ADC) (Cont'd)

10.9.3 Functional Description

The conversion is monotonic, meaning that the result never decreases if the analog input does not and never increases if the analog input does not.

If the input voltage (V_{AIN}) is greater than V_{AREF} (high-level voltage reference) then the conversion result is FFh in the ADCDRH register and 03h in the ADCDRL register (without overflow indication).

If the input voltage (V_{AIN}) is lower than V_{SSA} (low-level voltage reference) then the conversion result in the ADCDRH and ADCDRL registers is 00 00h.

The A/D converter is linear and the digital result of the conversion is stored in the ADCDRH and ADCDRL registers. The accuracy of the conversion is described in the Electrical Characteristics Section.

R_{AIN} is the maximum recommended impedance for an analog input signal. If the impedance is too high, this will result in a loss of accuracy due to leakage and sampling not being completed in the allotted time.

10.9.3.1 A/D Converter Configuration

The analog input ports must be configured as input, no pull-up, no interrupt. Refer to the «I/O ports» chapter. Using these pins as analog inputs does not affect the ability of the port to be read as a logic input.

In the ADCCSR register:

- Select the CS[3:0] bits to assign the analog channel to convert.

10.9.3.2 Starting the Conversion

In the ADCCSR register:

- Set the ADON bit to enable the A/D converter and to start the conversion. From this time on, the ADC performs a continuous conversion of the selected channel.

When a conversion is complete:

- The EOC bit is set by hardware.
- The result is in the ADCDR registers.

A read to the ADCDRH resets the EOC bit.

To read the 10 bits, perform the following steps:

1. Poll the EOC bit
2. Read the ADCDRL register
3. Read the ADCDRH register. This clears EOC automatically.

Note: The data is not latched, so both the low and the high data register must be read before the next conversion is complete, so it is recommended to disable interrupts while reading the conversion result.

To read only 8 bits, perform the following steps:

1. Poll the EOC bit
2. Read the ADCDRH register. This clears EOC automatically.

10.9.3.3 Changing the conversion channel

The application can change channels during conversion. When software modifies the CH[3:0] bits in the ADCCSR register, the current conversion is stopped, the EOC bit is cleared, and the A/D converter starts converting the newly selected channel.

10.9.4 Low Power Modes

Note: The A/D converter may be disabled by resetting the ADON bit. This feature allows reduced power consumption when no conversion is needed and between single shot conversions.

Mode	Description
WAIT	No effect on A/D Converter
HALT	A/D Converter disabled. After wakeup from Halt mode, the A/D Converter requires a stabilization time t_{STAB} (see Electrical Characteristics) before accurate conversions can be performed.

10.9.5 Interrupts

None.

10-BIT A/D CONVERTER (ADC) (Cont'd)

10.9.6 Register Description

CONTROL/STATUS REGISTER (ADCCSR)

Read/Write (Except bit 7 read only)

Reset Value: 0000 0000 (00h)

7							0
EOC	SPEED	ADON	0	CH3	CH2	CH1	CH0

Bit 7 = EOC *End of Conversion*
 This bit is set by hardware. It is cleared by hardware when software reads the ADCDRH register or writes to any bit of the ADCCSR register.
 0: Conversion is not complete
 1: Conversion complete

Bit 6 = SPEED *ADC clock selection*
 This bit is set and cleared by software.
 0: $f_{ADC} = f_{CPU}/4$
 1: $f_{ADC} = f_{CPU}/2$

Bit 5 = ADON *A/D Converter on*
 This bit is set and cleared by software.
 0: Disable ADC and stop conversion
 1: Enable ADC and start conversion

Bit 4 = Reserved. Must be kept cleared.

Bit 3:0 = CH[3:0] *Channel Selection*
 These bits are set and cleared by software. They select the analog input to convert.

Channel Pin*	CH3	CH2	CH1	CH0
AIN0	0	0	0	0
AIN1	0	0	0	1
AIN2	0	0	1	0
AIN3	0	0	1	1
AIN4	0	1	0	0
AIN5	0	1	0	1
AIN6	0	1	1	0
AIN7	0	1	1	1
AIN8	1	0	0	0
AIN9	1	0	0	1
AIN10	1	0	1	0
AIN11	1	0	1	1
AIN12	1	1	0	0
AIN13	1	1	0	1
AIN14	1	1	1	0
AIN15	1	1	1	1

*The number of channels is device dependent. Refer to the device pinout description.

DATA REGISTER (ADCDRH)

Read Only

Reset Value: 0000 0000 (00h)

7							0
D9	D8	D7	D6	D5	D4	D3	D2

Bit 7:0 = D[9:2] *MSB of Converted Analog Value*

DATA REGISTER (ADCDRL)

Read Only

Reset Value: 0000 0000 (00h)

7							0
0	0	0	0	0	0	D1	D0

Bit 7:2 = Reserved. Forced by hardware to 0.

Bit 1:0 = D[1:0] *LSB of Converted Analog Value*

10-BIT A/D CONVERTER (Cont'd)**Table 25. ADC Register Map and Reset Values**

Address (Hex.)	Register Label	7	6	5	4	3	2	1	0
0070h	ADCCSR Reset Value	EOC 0	SPEED 0	ADON 0	0	CH3 0	CH2 0	CH1 0	CH0 0
0071h	ADCDRH Reset Value	D9 0	D8 0	D7 0	D6 0	D5 0	D4 0	D3 0	D2 0
0072h	ADCRL Reset Value	0	0	0	0	0	0	D1 0	D0 0

11 INSTRUCTION SET

11.1 CPU ADDRESSING MODES

The CPU features 17 different addressing modes which can be classified in 7 main groups:

Addressing Mode	Example
Inherent	nop
Immediate	ld A,#\$55
Direct	ld A,\$55
Indexed	ld A,(\$55,X)
Indirect	ld A,([\$55],X)
Relative	jrne loop
Bit operation	bset byte,#5

The CPU Instruction set is designed to minimize the number of bytes required per instruction: To do

so, most of the addressing modes may be subdivided in two sub-modes called long and short:

- Long addressing mode is more powerful because it can use the full 64 Kbyte address space, however it uses more bytes and more CPU cycles.
- Short addressing mode is less powerful because it can generally only access page zero (0000h - 00FFh range), but the instruction size is more compact, and faster. All memory to memory instructions use short addressing modes only (CLR, CPL, NEG, BSET, BRES, BTJT, BTJF, INC, DEC, RLC, RRC, SLL, SRL, SRA, SWAP)

The ST7 Assembler optimizes the use of long and short addressing modes.

Table 26. CPU Addressing Mode Overview

Mode		Syntax	Destination	Pointer Address (Hex.)	Pointer Size (Hex.)	Length (Bytes)
Inherent		nop				+ 0
Immediate		ld A,#\$55				+ 1
Short	Direct	ld A,\$10	00..FF			+ 1
Long	Direct	ld A,\$1000	0000..FFFF			+ 2
No Offset	Direct	Indexed ld A,(X)	00..FF			+ 0
Short	Direct	Indexed ld A,(\$10,X)	00..1FE			+ 1
Long	Direct	Indexed ld A,(\$1000,X)	0000..FFFF			+ 2
Short	Indirect	ld A,[\$10]	00..FF	00..FF	byte	+ 2
Long	Indirect	ld A,[\$10.w]	0000..FFFF	00..FF	word	+ 2
Short	Indirect	Indexed ld A,([\$10],X)	00..1FE	00..FF	byte	+ 2
Long	Indirect	Indexed ld A,([\$10.w],X)	0000..FFFF	00..FF	word	+ 2
Relative	Direct	jrne loop	PC+/-127			+ 1
Relative	Indirect	jrne [\$10]	PC+/-127	00..FF	byte	+ 2
Bit	Direct	bset \$10,#7	00..FF			+ 1
Bit	Indirect	bset [\$10],#7	00..FF	00..FF	byte	+ 2
Bit	Direct	Relative btjt \$10,#7,skip	00..FF			+ 2
Bit	Indirect	Relative btjt [\$10],#7,skip	00..FF	00..FF	byte	+ 3

INSTRUCTION SET OVERVIEW (Cont'd)

11.1.1 Inherent

All Inherent instructions consist of a single byte. The opcode fully specifies all the required information for the CPU to process the operation.

Inherent Instruction	Function
NOP	No operation
TRAP	S/W Interrupt
WFI	Wait For Interrupt (Low Power Mode)
HALT	Halt Oscillator (Lowest Power Mode)
RET	Sub-routine Return
IRET	Interrupt Sub-routine Return
SIM	Set Interrupt Mask (level 3)
RIM	Reset Interrupt Mask (level 0)
SCF	Set Carry Flag
RCF	Reset Carry Flag
RSP	Reset Stack Pointer
LD	Load
CLR	Clear
PUSH/POP	Push/Pop to/from the stack
INC/DEC	Increment/Decrement
TNZ	Test Negative or Zero
CPL, NEG	1 or 2 Complement
MUL	Byte Multiplication
SLL, SRL, SRA, RLC, RRC	Shift and Rotate Operations
SWAP	Swap Nibbles

11.1.2 Immediate

Immediate instructions have two bytes, the first byte contains the opcode, the second byte contains the operand value.

Immediate Instruction	Function
LD	Load
CP	Compare
BCP	Bit Compare
AND, OR, XOR	Logical Operations
ADC, ADD, SUB, SBC	Arithmetic Operations

11.1.3 Direct

In Direct instructions, the operands are referenced by their memory address.

The direct addressing mode consists of two sub-modes:

Direct (short)

The address is a byte, thus requires only one byte after the opcode, but only allows 00 - FF addressing space.

Direct (long)

The address is a word, thus allowing 64 Kbyte addressing space, but requires 2 bytes after the opcode.

11.1.4 Indexed (No Offset, Short, Long)

In this mode, the operand is referenced by its memory address, which is defined by the unsigned addition of an index register (X or Y) with an offset.

The indirect addressing mode consists of three sub-modes:

Indexed (No Offset)

There is no offset, (no extra byte after the opcode), and allows 00 - FF addressing space.

Indexed (Short)

The offset is a byte, thus requires only one byte after the opcode and allows 00 - 1FE addressing space.

Indexed (long)

The offset is a word, thus allowing 64 Kbyte addressing space and requires 2 bytes after the opcode.

11.1.5 Indirect (Short, Long)

The required data byte to do the operation is found by its memory address, located in memory (pointer).

The pointer address follows the opcode. The indirect addressing mode consists of two sub-modes:

Indirect (short)

The pointer address is a byte, the pointer size is a byte, thus allowing 00 - FF addressing space, and requires 1 byte after the opcode.

Indirect (long)

The pointer address is a byte, the pointer size is a word, thus allowing 64 Kbyte addressing space, and requires 1 byte after the opcode.

INSTRUCTION SET OVERVIEW (Cont'd)**11.1.6 Indirect Indexed (Short, Long)**

This is a combination of indirect and short indexed addressing modes. The operand is referenced by its memory address, which is defined by the unsigned addition of an index register value (X or Y) with a pointer value located in memory. The pointer address follows the opcode.

The indirect indexed addressing mode consists of two sub-modes:

Indirect Indexed (Short)

The pointer address is a byte, the pointer size is a byte, thus allowing 00 - 1FE addressing space, and requires 1 byte after the opcode.

Indirect Indexed (Long)

The pointer address is a byte, the pointer size is a word, thus allowing 64 Kbyte addressing space, and requires 1 byte after the opcode.

Table 27. Instructions Supporting Direct, Indexed, Indirect and Indirect Indexed Addressing Modes

Long and Short Instructions	Function
LD	Load
CP	Compare
AND, OR, XOR	Logical Operations
ADC, ADD, SUB, SBC	Arithmetic Additions/Subtractions operations
BCP	Bit Compare

Short Instructions Only	Function
CLR	Clear
INC, DEC	Increment/Decrement
TNZ	Test Negative or Zero
CPL, NEG	1 or 2 Complement
BSET, BRES	Bit Operations
BTJT, BTJF	Bit Test and Jump Operations
SLL, SRL, SRA, RLC, RRC	Shift and Rotate Operations
SWAP	Swap Nibbles
CALL, JP	Call or Jump subroutine

11.1.7 Relative mode (Direct, Indirect)

This addressing mode is used to modify the PC register value, by adding an 8-bit signed offset to it.

Available Relative Direct/Indirect Instructions	Function
JRxx	Conditional Jump
CALLR	Call Relative

The relative addressing mode consists of two sub-modes:

Relative (Direct)

The offset is following the opcode.

Relative (Indirect)

The offset is defined in memory, which address follows the opcode.

INSTRUCTION SET OVERVIEW (Cont'd)

11.2 INSTRUCTION GROUPS

The ST7 family devices use an Instruction Set consisting of 63 instructions. The instructions may be subdivided into 13 main groups as illustrated in the following table:

Load and Transfer	LD	CLR						
Stack operation	PUSH	POP	RSP					
Increment/Decrement	INC	DEC						
Compare and Tests	CP	TNZ	BCP					
Logical operations	AND	OR	XOR	CPL	NEG			
Bit Operation	BSET	BRES						
Conditional Bit Test and Branch	BTJT	BTJF						
Arithmetic operations	ADC	ADD	SUB	SBC	MUL			
Shift and Rotates	SLL	SRL	SRA	RLC	RRC	SWAP	SLA	
Unconditional Jump or Call	JRA	JRT	JRF	JP	CALL	CALLR	NOP	RET
Conditional Branch	JRxx							
Interrupt management	TRAP	WFI	HALT	IRET				
Condition Code Flag modification	SIM	RIM	SCF	RCF				

Using a pre-byte

The instructions are described with one to four opcodes.

In order to extend the number of available opcodes for an 8-bit CPU (256 opcodes), three different prebyte opcodes are defined. These prebytes modify the meaning of the instruction they precede.

The whole instruction becomes:

- PC-2 End of previous instruction
- PC-1 Prebyte
- PC opcode
- PC+1 Additional word (0 to 2) according to the number of bytes required to compute the effective address

These prebytes enable instruction in Y as well as indirect addressing modes to be implemented. They precede the opcode of the instruction in X or the instruction using direct addressing mode. The prebytes are:

PDY 90 Replace an X based instruction using immediate, direct, indexed, or inherent addressing mode by a Y one.

PIX 92 Replace an instruction using direct, direct bit, or direct relative addressing mode to an instruction using the corresponding indirect addressing mode.

It also changes an instruction using X indexed addressing mode to an instruction using indirect X indexed addressing mode.

PIY 91 Replace an instruction using X indirect indexed addressing mode by a Y one.

INSTRUCTION SET OVERVIEW (Cont'd)

Mnemo	Description	Function/Example	Dst	Src	I1	H	I0	N	Z	C
ADC	Add with Carry	$A = A + M + C$	A	M		H		N	Z	C
ADD	Addition	$A = A + M$	A	M		H		N	Z	C
AND	Logical And	$A = A . M$	A	M				N	Z	
BCP	Bit compare A, Memory	tst (A . M)	A	M				N	Z	
BRES	Bit Reset	bres Byte, #3	M							
BSET	Bit Set	bset Byte, #3	M							
BTJF	Jump if bit is false (0)	btjf Byte, #3, Jmp1	M							C
BTJT	Jump if bit is true (1)	btjt Byte, #3, Jmp1	M							C
CALL	Call subroutine									
CALLR	Call subroutine relative									
CLR	Clear		reg, M					0	1	
CP	Arithmetic Compare	tst(Reg - M)	reg	M				N	Z	C
CPL	One Complement	$A = \text{FFH}-A$	reg, M					N	Z	1
DEC	Decrement	dec Y	reg, M					N	Z	
HALT	Halt				1		0			
IRET	Interrupt routine return	Pop CC, A, X, PC			I1	H	I0	N	Z	C
INC	Increment	inc X	reg, M					N	Z	
JP	Absolute Jump	jp [TBL.w]								
JRA	Jump relative always									
JRT	Jump relative									
JRF	Never jump	jrf *								
JRIH	Jump if ext. INT pin = 1	(ext. INT pin high)								
JRIL	Jump if ext. INT pin = 0	(ext. INT pin low)								
JRH	Jump if H = 1	H = 1 ?								
JRNH	Jump if H = 0	H = 0 ?								
JRM	Jump if I1:0 = 11	I1:0 = 11 ?								
JRNM	Jump if I1:0 <> 11	I1:0 <> 11 ?								
JRMI	Jump if N = 1 (minus)	N = 1 ?								
JRPL	Jump if N = 0 (plus)	N = 0 ?								
JREQ	Jump if Z = 1 (equal)	Z = 1 ?								
JRNE	Jump if Z = 0 (not equal)	Z = 0 ?								
JRC	Jump if C = 1	C = 1 ?								
JRNC	Jump if C = 0	C = 0 ?								
JRULT	Jump if C = 1	Unsigned <								
JRUGE	Jump if C = 0	Jmp if unsigned >=								
JRUGT	Jump if (C + Z = 0)	Unsigned >								

INSTRUCTION SET OVERVIEW (Cont'd)

Mnemo	Description	Function/Example	Dst	Src	I1	H	I0	N	Z	C
JRULE	Jump if (C + Z = 1)	Unsigned <=								
LD	Load	dst <= src	reg, M	M, reg				N	Z	
MUL	Multiply	X,A = X * A	A, X, Y	X, Y, A		0				0
NEG	Negate (2's compl)	neg \$10	reg, M					N	Z	C
NOP	No Operation									
OR	OR operation	A = A + M	A	M				N	Z	
POP	Pop from the Stack	pop reg	reg	M						
		pop CC	CC	M	I1	H	I0	N	Z	C
PUSH	Push onto the Stack	push Y	M	reg, CC						
RCF	Reset carry flag	C = 0								0
RET	Subroutine Return									
RIM	Enable Interrupts	I1:0 = 10 (level 0)			1		0			
RLC	Rotate left true C	C <= A <= C	reg, M					N	Z	C
RRC	Rotate right true C	C => A => C	reg, M					N	Z	C
RSP	Reset Stack Pointer	S = Max allowed								
SBC	Subtract with Carry	A = A - M - C	A	M				N	Z	C
SCF	Set carry flag	C = 1								1
SIM	Disable Interrupts	I1:0 = 11 (level 3)			1		1			
SLA	Shift left Arithmetic	C <= A <= 0	reg, M					N	Z	C
SLL	Shift left Logic	C <= A <= 0	reg, M					N	Z	C
SRL	Shift right Logic	0 => A => C	reg, M					0	Z	C
SRA	Shift right Arithmetic	A7 => A => C	reg, M					N	Z	C
SUB	Subtraction	A = A - M	A	M				N	Z	C
SWAP	SWAP nibbles	A7-A4 <=> A3-A0	reg, M					N	Z	
TNZ	Test for Neg & Zero	tnz !b1						N	Z	
TRAP	S/W trap	S/W interrupt			1		1			
WFI	Wait for Interrupt				1		0			
XOR	Exclusive OR	A = A XOR M	A	M				N	Z	

12 ELECTRICAL CHARACTERISTICS

12.1 PARAMETER CONDITIONS

Unless otherwise specified, all voltages are referred to V_{SS} .

12.1.1 Minimum and Maximum values

Unless otherwise specified the minimum and maximum values are guaranteed in the worst conditions of ambient temperature, supply voltage and frequencies by tests in production on 100% of the devices with an ambient temperature at $T_A=25^\circ\text{C}$ and $T_A=T_{A\text{max}}$ (given by the selected temperature range).

Data based on characterization results, design simulation and/or technology characteristics are indicated in the table footnotes and are not tested in production. Based on characterization, the minimum and maximum values refer to sample tests and represent the mean value plus or minus three times the standard deviation ($\text{mean} \pm 3\Sigma$).

12.1.2 Typical values

Unless otherwise specified, typical data are based on $T_A=25^\circ\text{C}$, $V_{DD}=5\text{V}$. They are given only as design guidelines and are not tested.

12.1.3 Typical curves

Unless otherwise specified, all typical curves are given only as design guidelines and are not tested.

12.1.4 Loading capacitor

The loading conditions used for pin parameter measurement are shown in [Figure 84](#).

Figure 84. Pin loading conditions

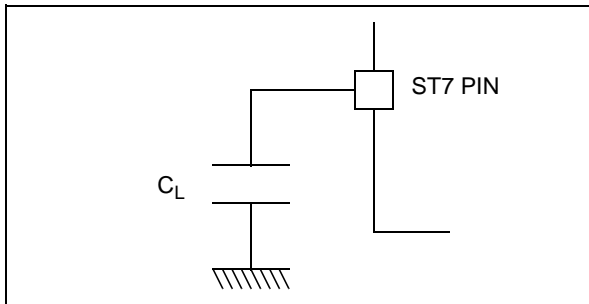

12.1.5 Pin input voltage

The input voltage measurement on a pin of the device is described in [Figure 85](#).

Figure 85. Pin input voltage

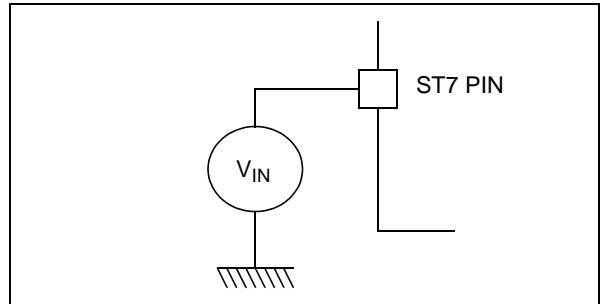

12.2 ABSOLUTE MAXIMUM RATINGS

Stresses above those listed as “absolute maximum ratings” may cause permanent damage to the device. This is a stress rating only and functional operation of the device under these condi-

tions is not implied. Exposure to maximum rating conditions for extended periods may affect device reliability.

12.2.1 Voltage Characteristics

Symbol	Ratings	Maximum value	Unit
$V_{DD} - V_{SS}$	Supply voltage	6.5	V
$V_{PP} - V_{SS}$	Programming Voltage	13	
$V_{IN}^{1) \& 2)}$	Input Voltage on true open drain pin	$V_{SS}-0.3$ to 6.5	
	Input voltage on any other pin	$V_{SS}-0.3$ to $V_{DD}+0.3$	
$ \Delta V_{DDx} $ and $ \Delta V_{SSx} $	Variations between different digital power pins	50	mV
$ V_{SSA} - V_{SSx} $	Variations between digital and analog ground pins	50	
$V_{ESD(HBM)}$	Electro-static discharge voltage (Human Body Model)	see section 12.7.3 on page 181	
$V_{ESD(MM)}$	Electro-static discharge voltage (Machine Model)		

12.2.2 Current Characteristics

Symbol	Ratings	Maximum value	Unit
I_{VDD}	Total current into V_{DD} power lines (source) ³⁾	150	mA
I_{VSS}	Total current out of V_{SS} ground lines (sink) ³⁾	150	
I_{IO}	Output current sunk by any standard I/O and control pin	25	mA
	Output current sunk by any high sink I/O pin	50	
	Output current source by any I/Os and control pin	- 25	
$I_{INJ(PIN)}^{2) \& 4)}$	Injected current on V_{PP} pin	± 5	
	Injected current on \overline{RESET} pin	± 5	
	Injected current on OSC1 and OSC2 pins	± 5	
	Injected current on PC6 (Flash devices only)	+ 5	
	Injected current on any other pin ^{5) & 6)}	± 5	
$\Sigma I_{INJ(PIN)}^{2)}$	Total injected current (sum of all I/O and control pins) ⁵⁾	± 25	

Notes:

1. Directly connecting the \overline{RESET} and I/O pins to V_{DD} or V_{SS} could damage the device if an unintentional internal reset is generated or an unexpected change of the I/O configuration occurs (for example, due to a corrupted program counter). To guarantee safe operation, this connection has to be done through a pull-up or pull-down resistor (typical: 4.7k Ω for \overline{RESET} , 10k Ω for I/Os). For the same reason, unused I/O pins must not be directly tied to V_{DD} or V_{SS} .
2. $I_{INJ(PIN)}$ must never be exceeded. This is implicitly insured if V_{IN} maximum is respected. If V_{IN} maximum cannot be respected, the injection current must be limited externally to the $I_{INJ(PIN)}$ value. A positive injection is induced by $V_{IN} > V_{DD}$ while a negative injection is induced by $V_{IN} < V_{SS}$. For true open-drain pads, there is no positive injection current, and the corresponding V_{IN} maximum must always be respected
3. All power (V_{DD}) and ground (V_{SS}) lines must always be connected to the external supply.
4. Negative injection disturbs the analog performance of the device. See note in “[ADC Accuracy](#)” on page 196. For best reliability, it is recommended to avoid negative injection of more than 1.6mA.
5. When several inputs are submitted to a current injection, the maximum $\Sigma I_{INJ(PIN)}$ is the absolute sum of the positive and negative injected currents (instantaneous values). These results are based on characterisation with $\Sigma I_{INJ(PIN)}$ maximum current injection on four I/O port pins of the device.
6. True open drain I/O port pins do not accept positive injection.

12.2.3 Thermal Characteristics

Symbol	Ratings	Value	Unit
T _{STG}	Storage temperature range	-65 to +150	°C
T _J	Maximum junction temperature (see Section 13.2 THERMAL CHARACTERISTICS)		

12.3 OPERATING CONDITIONS

12.3.1 General Operating Conditions

Symbol	Parameter	Conditions	Min	Max	Unit
f _{CPU}	Internal clock frequency		0	8	MHz
V _{DD}	Standard voltage range (except Flash Write/Erase)		3.8	5.5	V
	Operating Voltage for Flash Write/Erase	V _{PP} = 11.4 to 12.6V	4.5	5.5	
T _A	Ambient temperature range	1 Suffix Version	0	70	°C
		5 Suffix Version	-10	85	
		6 or A Suffix Versions	-40	85	
		7 or B Suffix Versions	-40	105	
		C Suffix Version	-40	125	

Figure 86. f_{CPU} Max Versus V_{DD}

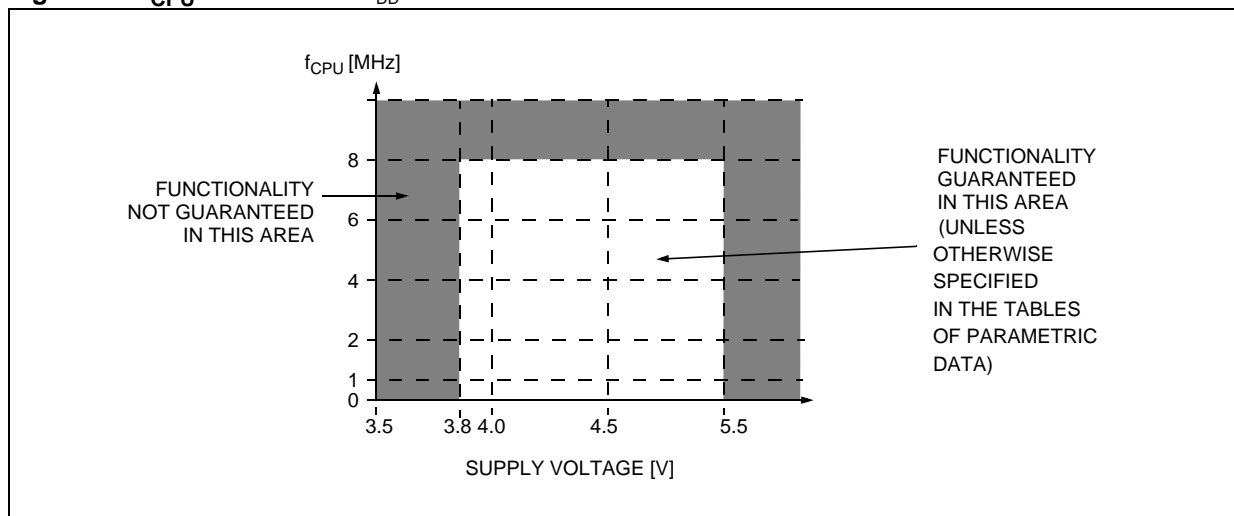

Note: Some temperature ranges are only available with a specific package and memory size. Refer to Ordering Information.

OPERATING CONDITIONS (Cont'd)

12.3.2 Operating Conditions with Low Voltage Detector (LVD)

Subject to general operating conditions for V_{DD} , f_{CPU} , and T_A .

Symbol	Parameter	Conditions	Min	Typ	Max	Unit
$V_{IT+(LVD)}$	Reset release threshold (V_{DD} rise)	VD level = High in option byte	4.0 ¹⁾	4.2	4.5	V
		VD level = Med. in option byte ³⁾	3.55 ¹⁾	3.75	4.0 ¹⁾	
		VD level = Low in option byte ³⁾	2.95 ¹⁾	3.15	3.35 ¹⁾	
$V_{IT-(LVD)}$	Reset generation threshold (V_{DD} fall)	VD level = High in option byte	3.8	4.0	4.25 ¹⁾	V
		VD level = Med. in option byte ³⁾	3.35 ¹⁾	3.55	3.75 ¹⁾	
		VD level = Low in option byte ³⁾	2.8 ¹⁾	3.0	3.15 ¹⁾	
$V_{hys(LVD)}$	LVD voltage threshold hysteresis ¹⁾	$V_{IT+(LVD)} - V_{IT-(LVD)}$	150	200	250	mV
V_{tPOR}	V_{DD} rise time ¹⁾²⁾	Flash device, LVD enabled	6 μ s/V		20ms/V	
		ROM device, LVD enabled	6 μ s/V		100ms/V	
$t_g(V_{DD})$	V_{DD} glitches filtered (not detected) by LVD ¹⁾				40	ns

Notes:

1. Data based on characterization results, tested in production for ROM devices only.
2. When V_{tPOR} is faster than 100 μ s/V, the Reset signal is released after a delay of max. 42 μ s after V_{DD} crosses the $V_{IT+(LVD)}$ threshold.
3. If the medium or low thresholds are selected, the detection may occur outside the specified operating voltage range. Below 3.8V, device operation is not guaranteed.

12.3.3 Auxiliary Voltage Detector (AVD) Thresholds

Subject to general operating conditions for V_{DD} , f_{CPU} , and T_A .

Symbol	Parameter	Conditions	Min	Typ	Max	Unit
$V_{IT+(AVD)}$	1 \Rightarrow 0 AVDF flag toggle threshold (V_{DD} rise)	VD level = High in option byte	4.4 ¹⁾	4.6	4.9	V
		VD level = Med. in option byte	3.95 ¹⁾	4.15	4.4 ¹⁾	
		VD level = Low in option byte	3.4 ¹⁾	3.6	3.8 ¹⁾	
$V_{IT-(AVD)}$	0 \Rightarrow 1 AVDF flag toggle threshold (V_{DD} fall)	VD level = High in option byte	4.2	4.4	4.65 ¹⁾	V
		VD level = Med. in option byte	3.75 ¹⁾	4.0	4.2 ¹⁾	
		VD level = Low in option byte	3.2 ¹⁾	3.4	3.6 ¹⁾	
$V_{hys(AVD)}$	AVD voltage threshold hysteresis	$V_{IT+(AVD)} - V_{IT-(AVD)}$		200		mV
ΔV_{IT-}	Voltage drop between AVD flag set and LVD reset activated	$V_{IT-(AVD)} - V_{IT-(LVD)}$		450		mV

1. Data based on characterization results, tested in production for ROM devices only.

12.3.4 External Voltage Detector (EVD) Thresholds

Subject to general operating conditions for V_{DD} , f_{CPU} , and T_A .

Symbol	Parameter	Conditions	Min	Typ	Max	Unit
$V_{IT+(EVD)}$	1 \Rightarrow 0 AVDF flag toggle threshold (V_{DD} rise) ¹⁾		1.15	1.26	1.35	V
$V_{IT-(EVD)}$	0 \Rightarrow 1 AVDF flag toggle threshold (V_{DD} fall) ¹⁾		1.1	1.2	1.3	
$V_{hys(EVD)}$	EVD voltage threshold hysteresis	$V_{IT+(EVD)} - V_{IT-(EVD)}$		200		mV

1. Data based on characterization results, not tested in production.

12.4 SUPPLY CURRENT CHARACTERISTICS

The following current consumption specified for the ST7 functional operating modes over temperature range does not take into account the clock source current consumption. To get the total device consumption, the two current values must be added (except for HALT mode for which the clock is stopped).

12.4.1 CURRENT CONSUMPTION

Symbol	Parameter	Conditions	Flash Devices		ROM Devices		Unit
			Typ	Max ¹⁾	Typ	Max ¹⁾	
I _{DD}	Supply current in RUN mode ²⁾	f _{OSC} =2MHz, f _{CPU} =1MHz f _{OSC} =4MHz, f _{CPU} =2MHz f _{OSC} =8MHz, f _{CPU} =4MHz f _{OSC} =16MHz, f _{CPU} =8MHz	1.3 2.0 3.6 7.1	3.0 5.0 8.0 15.0	1.3 2.0 3.6 7.1	2.0 3.0 5.0 10.0	mA
	Supply current in SLOW mode ²⁾	f _{OSC} =2MHz, f _{CPU} =62.5kHz f _{OSC} =4MHz, f _{CPU} =125kHz f _{OSC} =8MHz, f _{CPU} =250kHz f _{OSC} =16MHz, f _{CPU} =500kHz	600 700 800 1100	2700 3000 3600 4000	600 700 800 1100	1800 2100 2400 3000	μA
	Supply current in WAIT mode ²⁾	f _{OSC} =2MHz, f _{CPU} =1MHz f _{OSC} =4MHz, f _{CPU} =2MHz f _{OSC} =8MHz, f _{CPU} =4MHz f _{OSC} =16MHz, f _{CPU} =8MHz	1.0 1.5 2.5 4.5	3.0 4.0 5.0 7.0	1.0 1.5 2.5 4.5	1.3 2.0 3.3 6.0	mA
	Supply current in SLOW WAIT mode ²⁾	f _{OSC} =2MHz, f _{CPU} =62.5kHz f _{OSC} =4MHz, f _{CPU} =125kHz f _{OSC} =8MHz, f _{CPU} =250kHz f _{OSC} =16MHz, f _{CPU} =500kHz	580 650 770 1050	1200 1300 1800 2000	70 100 200 350	200 300 600 1200	μA
	Supply current in HALT mode ³⁾	-40°C ≤ T _A ≤ +85°C -40°C ≤ T _A ≤ +125°C	<1 <1	10 50	<1 <1	10 50	μA
I _{DD}	Supply current in ACTIVE-HALT mode ⁴⁾	f _{OSC} =2MHz f _{OSC} =4MHz f _{OSC} =8MHz f _{OSC} =16MHz	80 160 325 650	No max. guaran- teed	15 30 60 120	25 50 100 200	μA

Notes:

- Data based on characterization results, tested in production at V_{DD} max. and f_{CPU} max.
- Measurements are done in the following conditions:
 - Program executed from RAM, CPU running with RAM access. The increase in consumption when executing from Flash is 50%.
 - All I/O pins in input mode with a static value at V_{DD} or V_{SS} (no load)
 - All peripherals in reset state.
 - LVD disabled.
 - Clock input (OSC1) driven by external square wave.
 - In SLOW and SLOW WAIT mode, f_{CPU} is based on f_{OSC} divided by 32.
 To obtain the total current consumption of the device, add the clock source (Section 12.4.2) and the peripheral power consumption (Section 12.4.3).
- All I/O pins in push-pull 0 mode (when applicable) with a static value at V_{DD} or V_{SS} (no load), LVD disabled. Data based on characterization results, tested in production at V_{DD} max. and f_{CPU} max.
- Data based on characterisation results, not tested in production. All I/O pins in push-pull 0 mode (when applicable) with a static value at V_{DD} or V_{SS} (no load); clock input (OSC1) driven by external square wave, LVD disabled. To obtain the total current consumption of the device, add the clock source consumption (Section 12.4.2).

SUPPLY CURRENT CHARACTERISTICS (Cont'd)

12.4.1.1 Power Consumption vs f_{CPU} : Flash Devices

Figure 87. Typical I_{DD} in RUN mode

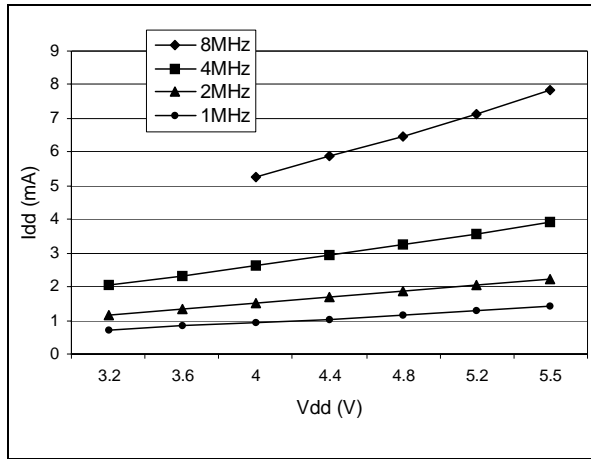

Figure 89. Typical I_{DD} in WAIT mode

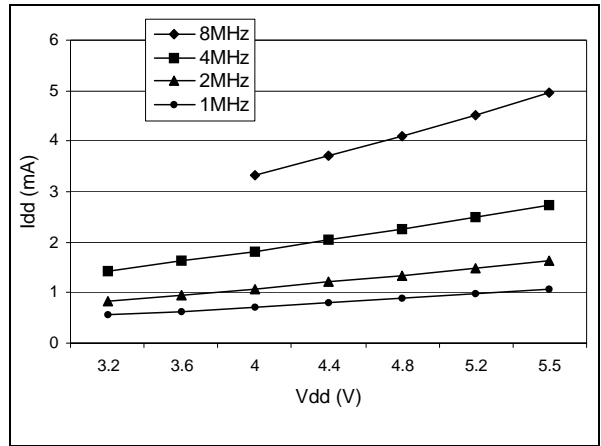

Figure 88. Typical I_{DD} in SLOW mode

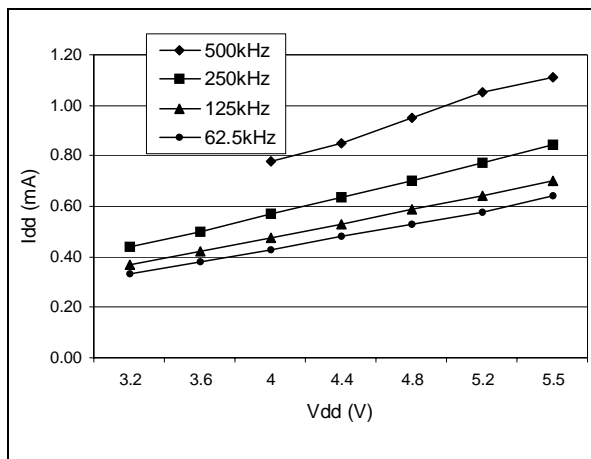
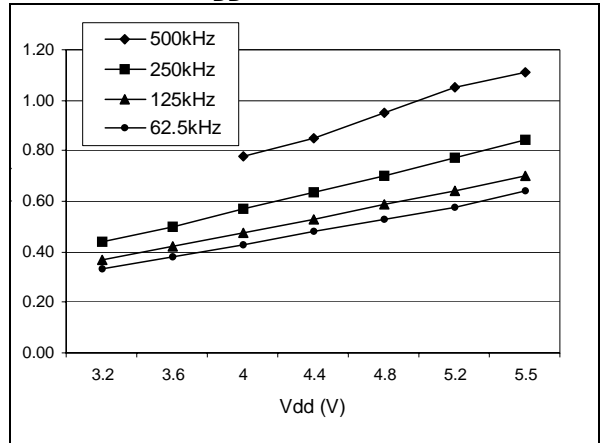

Figure 90. Typ. I_{DD} in SLOW-WAIT mode



SUPPLY CURRENT CHARACTERISTICS (Cont'd)**12.4.2 Supply and Clock Managers**

The previous current consumption specified for the ST7 functional operating modes over temperature range does not take into account the clock source current consumption. To get the total device consumption, the two current values must be added (except for HALT mode).

Symbol	Parameter	Conditions	Typ	Max	Unit
$I_{DD(RCINT)}$	Supply current of internal RC oscillator		625		μA
$I_{DD(RES)}$	Supply current of resonator oscillator ^{1) & 2)}		see section 12.5.3 on page 174		
$I_{DD(PLL)}$	PLL supply current	$V_{DD} = 5V$	360		
$I_{DD(LVD)}$	LVD supply current	$V_{DD} = 5V$	150	300	

Notes:

- 1.. Data based on characterization results done with the external components specified in [Section 12.5.3](#), not tested in production.
2. As the oscillator is based on a current source, the consumption does not depend on the voltage.

SUPPLY CURRENT CHARACTERISTICS (Cont'd)

12.4.3 On-Chip Peripherals

Measured on S72F521R9T3 on TQFP64 generic board $T_A = 25^\circ\text{C}$ $f_{\text{CPU}}=4\text{MHz}$.

Symbol	Parameter	Conditions	Typ	Unit
$I_{\text{DD(TIM)}}$	16-bit Timer supply current ¹⁾	$V_{\text{DD}}=5.0\text{V}$	50	μA
$I_{\text{DD(ART)}}$	ART PWM supply current ²⁾	$V_{\text{DD}}=5.0\text{V}$	75	μA
$I_{\text{DD(SPI)}}$	SPI supply current ³⁾	$V_{\text{DD}}=5.0\text{V}$	400	μA
$I_{\text{DD(SCI)}}$	SCI supply current ⁴⁾	$V_{\text{DD}}=5.0\text{V}$	400	μA
$I_{\text{DD(I2C)}}$	I2C supply current ⁵⁾	$V_{\text{DD}}=5.0\text{V}$	175	μA
$I_{\text{DD(ADC)}}$	ADC supply current when converting ⁶⁾	$V_{\text{DD}}=5.0\text{V}$	400	μA
$I_{\text{DD(CAN)}}$	CAN supply current ⁵⁾	$V_{\text{DD}}=5.0\text{V}$	400	μA

Notes:

1. Data based on a differential I_{DD} measurement between reset configuration (timer counter running at $f_{\text{CPU}}/4$) and timer counter stopped (only TIMD bit set). Data valid for one timer.
2. Data based on a differential I_{DD} measurement between reset configuration (timer stopped) and timer counter enabled (only TCE bit set).
3. Data based on a differential I_{DD} measurement between reset configuration (SPI disabled) and a permanent SPI master communication at maximum speed (data sent equal to 55h). This measurement includes the pad toggling consumption.
4. Data based on a differential I_{DD} measurement between SCI low power state (SCID=1) and a permanent SCI data transmit sequence.
5. Data based on a differential I_{DD} measurement between reset configuration (I2C disabled) and a permanent I2C master communication at 100kHz (data sent equal to 55h). This measurement include the pad toggling consumption (27kOhm external pull-up on clock and data lines).
6. Data based on a differential I_{DD} measurement between reset configuration and continuous A/D conversions.
7. Data based on a differential I_{DD} measurement between reset configuration (CAN disabled) and a permanent CAN data transmit sequence with RX and TX connected together. This measurement include the pad toggling consumption.

12.5 CLOCK AND TIMING CHARACTERISTICS

Subject to general operating conditions for V_{DD} , f_{CPU} , and T_A .

12.5.1 General Timings

Symbol	Parameter	Conditions	Min	Typ ¹⁾	Max	Unit
$t_{c(INST)}$	Instruction cycle time		2	3	12	t_{CPU}
		$f_{CPU}=8MHz$	250	375	1500	ns
$t_{V(IT)}$	Interrupt reaction time ²⁾ $t_{V(IT)} = \Delta t_{c(INST)} + 10$		10		22	t_{CPU}
		$f_{CPU}=8MHz$	1.25		2.75	μs

12.5.2 External Clock Source

Symbol	Parameter	Conditions	Min	Typ	Max	Unit
V_{OSC1H}	OSC1 input pin high level voltage	see Figure 91	$V_{DD}-1$		V_{DD}	V
V_{OSC1L}	OSC1 input pin low level voltage		V_{SS}		$V_{SS}+1$	
$t_{w(OSC1H)}$ $t_{w(OSC1L)}$	OSC1 high or low time ³⁾		5			ns
$t_r(OSC1)$ $t_f(OSC1)$	OSC1 rise or fall time ³⁾				15	
I_L	OSC1 Input leakage current	$V_{SS} \leq V_{IN} \leq V_{DD}$			± 1	μA

Figure 91. Typical Application with an External Clock Source

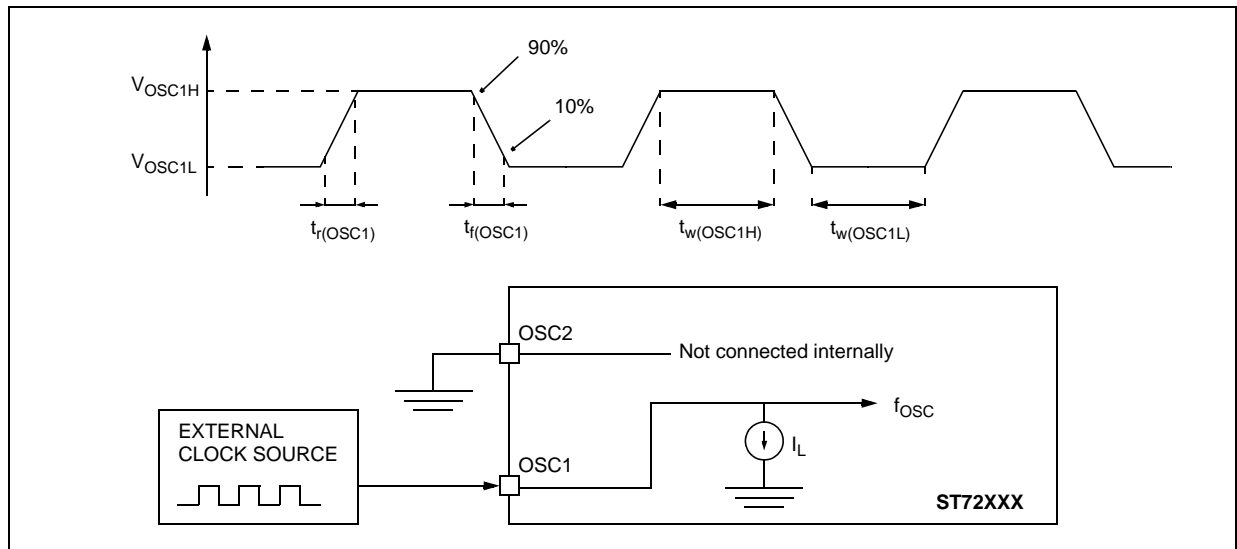

Notes:

1. Data based on typical application software.
2. Time measured between interrupt event and interrupt vector fetch. $\Delta t_{c(INST)}$ is the number of t_{CPU} cycles needed to finish the current instruction execution.
3. Data based on design simulation and/or technology characteristics, not tested in production.

CLOCK AND TIMING CHARACTERISTICS (Cont'd)

12.5.3 Crystal and Ceramic Resonator Oscillators

The ST7 internal clock can be supplied with four different Crystal/Ceramic resonator oscillators. All the information given in this paragraph are based on characterization results with specified typical external components. In the application, the resonator and the load capacitors have to be placed as

close as possible to the oscillator pins in order to minimize output distortion and start-up stabilization time. Refer to the crystal/ceramic resonator manufacturer for more details (frequency, package, accuracy...).

Symbol	Parameter	Conditions	Min	Max	Unit
f_{OSC}	Oscillator Frequency ¹⁾	LP: Low power oscillator MP: Medium power oscillator MS: Medium speed oscillator HS: High speed oscillator	1 >2 >4 >8	2 4 8 16	MHz
R_F	Feedback resistor ²⁾		20	40	k Ω
C_{L1} C_{L2}	Recommended load capacitance versus equivalent serial resistance of the crystal or ceramic resonator (R_S)	$R_S=200\Omega$ LP oscillator $R_S=200\Omega$ MP oscillator $R_S=200\Omega$ MS oscillator $R_S=100\Omega$ HS oscillator	22 22 18 15	56 46 33 33	pF

Symbol	Parameter	Conditions	Typ	Max	Unit
i_2	OSC2 driving current	$V_{DD}=5V$ $V_{IN}=V_{SS}$ LP oscillator MP oscillator MS oscillator HS oscillator	80 160 310 610	150 250 460 910	μA

Figure 92. Typical Application with a Crystal or Ceramic Resonator

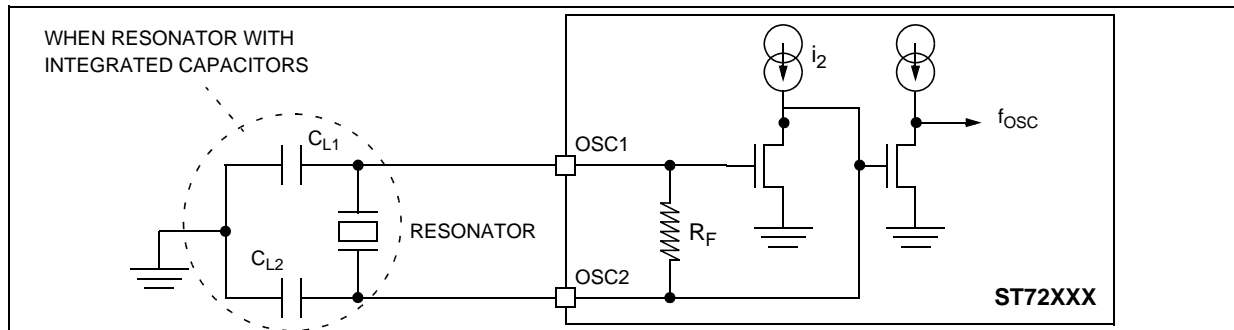

Notes:

1. The oscillator selection can be optimized in terms of supply current using an high quality resonator with small R_S value. Refer to crystal/ceramic resonator manufacturer for more details.
2. Data based on characterisation results, not tested in production.

CLOCK AND TIMING CHARACTERISTICS (Cont'd)

Supplier	f _{osc} (MHz)	Typical Ceramic Resonators	
		Reference ²⁾	Recommended OSCRANGE Option bit configuration
Murata	2	CSTCC2M00G56A-R0	MP Mode ³⁾
	4	CSTCR4M00G55B-R0	MS Mode
	8	CSTCE8M00G55A-R0	HS Mode
	16	CSTCE16M0G53A-R0	HS Mode

Notes:

1. Resonator characteristics given by the ceramic resonator manufacturer.
 2. SMD = [-R0: Plastic tape package (\varnothing =180mm), -B0: Bulk]
LEAD = [-A0: Flat pack package (Radial taping Ho= 18mm), -B0: Bulk]
 3. LP mode is not recommended for 2 MHz resonator because the peak to peak amplitude is too small (>0.8V)
- For more information on these resonators, please consult www.murata.com

CLOCK CHARACTERISTICS (Cont'd)

12.5.4 RC Oscillators

Symbol	Parameter	Conditions	Min	Typ	Max	Unit
f _{OSC (RCINT)}	Internal RC oscillator frequency See Figure 93	T _A =25°C, V _{DD} =5V	2	3.5	5.6	MHz

Figure 93. Typical f_{OSC(RCINT)} vs T_A

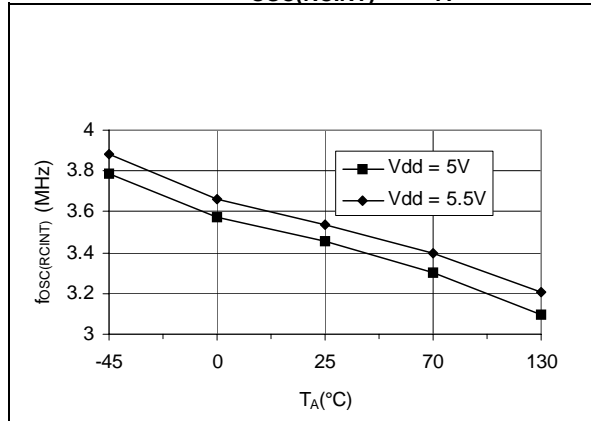

Note: To reduce disturbance to the RC oscillator, it is recommended to place decoupling capacitors between V_{DD} and V_{SS} as shown in [Figure 113](#)

CLOCK CHARACTERISTICS (Cont'd)

12.5.5 PLL Characteristics

Symbol	Parameter	Conditions	Min	Typ	Max	Unit
f_{OSC}	PLL input frequency range		2		4	MHz
$\Delta f_{CPU}/f_{CPU}$	Instantaneous PLL jitter ¹⁾	ROM device, $f_{OSC} = 4$ MHz.		0.7	2	%
		Flash device, $f_{OSC} = 4$ MHz.		1.0	2.5	
		Flash device, $f_{OSC} = 2$ MHz.		2.5	4.0	

Note:

1. Data characterized but not tested.

The user must take the PLL jitter into account in the application (for example in serial communication or sampling of high frequency signals). The PLL jitter is a periodic effect, which is integrated over several CPU cycles. Therefore the longer the period of the application signal, the less it will be impacted by the PLL jitter.

Figure 94 shows the PLL jitter integrated on application signals in the range 125kHz to 4MHz. At frequencies of less than 125kHz, the jitter is negligible.

Figure 94. Integrated PLL Jitter vs signal frequency¹

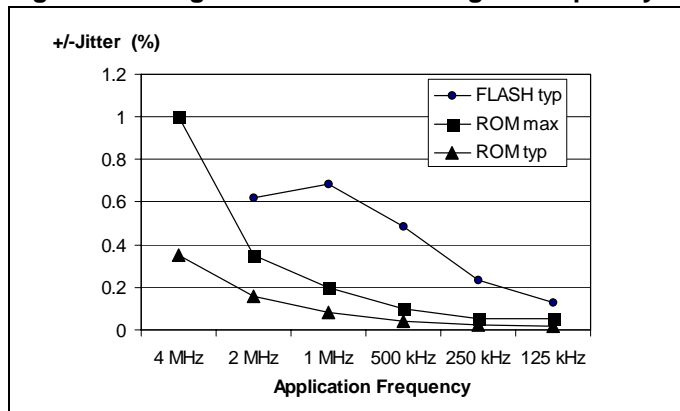

Note 1: Measurement conditions: $f_{CPU} = 8$ MHz.

12.6 MEMORY CHARACTERISTICS

12.6.1 RAM and Hardware Registers

Symbol	Parameter	Conditions	Min	Typ	Max	Unit
V _{RM}	Data retention mode ¹⁾	HALT mode (or RESET)	1.6			V

12.6.2 FLASH Memory

DUAL VOLTAGE HDFLASH MEMORY						
Symbol	Parameter	Conditions	Min ²⁾	Typ	Max ²⁾	Unit
f _{CPU}	Operating frequency	Read mode	0		8	MHz
		Write / Erase mode	1		8	
V _{PP}	Programming voltage ³⁾	4.5V ≤ V _{DD} ≤ 5.5V	11.4		12.6	V
I _{DD}	Supply current ⁴⁾	RUN mode (f _{CPU} = 4MHz)			3	mA
		Write / Erase		0		
		Power down mode / HALT		1	10	μA
I _{PP}	V _{PP} current ⁴⁾	Read (V _{PP} =12V)			200	μA
		Write / Erase			30	mA
t _{VPP}	Internal V _{PP} stabilization time			10		μs
t _{RET}	Data retention	T _A =55°C	20			years
N _{RW}	Write erase cycles	T _A =25°C	100			cycles
T _{PROG} T _{ERASE}	Programming or erasing temperature range		-40	25	85	°C

Notes:

1. Minimum V_{DD} supply voltage without losing data stored in RAM (in HALT mode or under RESET) or in hardware registers (only in HALT mode). Not tested in production.
2. Data based on characterization results, not tested in production.
3. V_{PP} must be applied only during the programming or erasing operation and not permanently for reliability reasons.
4. Data based on simulation results, not tested in production.

Warning: Do not connect 12V to V_{PP} before V_{DD} is powered on, as this may damage the device.

12.7 EMC CHARACTERISTICS

Susceptibility tests are performed on a sample basis during product characterization.

12.7.1 Functional EMS (Electro Magnetic Susceptibility)

Based on a simple running application on the product (toggling 2 LEDs through I/O ports), the product is stressed by two electro magnetic events until a failure occurs (indicated by the LEDs).

- **ESD:** Electro-Static Discharge (positive and negative) is applied on all pins of the device until a functional disturbance occurs. This test conforms with the IEC 1000-4-2 standard.
- **FTB:** A Burst of Fast Transient voltage (positive and negative) is applied to V_{DD} and V_{SS} through a 100pF capacitor, until a functional disturbance occurs. This test conforms with the IEC 1000-4-4 standard.

A device reset allows normal operations to be resumed. The test results are given in the table below based on the EMS levels and classes defined in application note AN1709.

12.7.1.1 Designing hardened software to avoid noise problems

EMC characterization and optimization are performed at component level with a typical application environment and simplified MCU software. It

should be noted that good EMC performance is highly dependent on the user application and the software in particular.

Therefore it is recommended that the user applies EMC software optimization and prequalification tests in relation with the EMC level requested for his application.

Software recommendations:

The software flowchart must include the management of runaway conditions such as:

- Corrupted program counter
- Unexpected reset
- Critical Data corruption (control registers...)

Prequalification trials:

Most of the common failures (unexpected reset and program counter corruption) can be reproduced by manually forcing a low state on the RESET pin or the Oscillator pins for 1 second.

To complete these trials, ESD stress can be applied directly on the device, over the range of specification values. When unexpected behaviour is detected, the software can be hardened to prevent unrecoverable errors occurring (see application note AN1015)

Symbol	Parameter	Conditions	Level/Class
V_{FESD}	Voltage limits to be applied on any I/O pin to induce a functional disturbance	Flash device: $V_{DD}=5V$, $T_A=+25^\circ C$, $f_{OSC}=8MHz$, conforms to IEC 1000-4-2	4B
		ROM device: $V_{DD}=5V$, $T_A=+25^\circ C$, $f_{OSC}=8MHz$, conforms to IEC 1000-4-2	3B
V_{FFTB}	Fast transient voltage burst limits to be applied through 100pF on V_{DD} and V_{DD} pins to induce a functional disturbance	Flash device: $V_{DD}=5V$, $T_A=+25^\circ C$, $f_{OSC}=8MHz$, conforms to IEC 1000-4-4	3B
V_{FFTB}	Fast transient voltage burst limits to be applied through 100pF on V_{DD} and V_{DD} pins to induce a functional disturbance	Flash device: $V_{DD}=5V$, $T_A=+25^\circ C$, $f_{OSC}=8MHz$, conforms to IEC 1000-4-4	3B

EMC CHARACTERISTICS (Cont'd)

12.7.2 Electro Magnetic Interference (EMI)

Based on a simple application running on the product (toggling 2 LEDs through the I/O ports), the product is monitored in terms of emission. This emission test is in line with the norm SAE J 1752/3 which specifies the board and the loading of each pin.

Symbol	Parameter	Conditions	Monitored Frequency Band	Max vs. [f _{OSC} /f _{CPU}]		Unit
				8/4MHz	16/8MHz	
S _{EMI}	Peak level	V _{DD} =5V, T _A =+25°C, TQFP64 14x14 package conforming to SAE J 1752/3	0.1MHz to 30MHz	15	15	dBμV
			30MHz to 130MHz	20	27	
			130MHz to 1GHz	0	5	
			SAE EMI Level	2.5	3.0	-

Notes:

1. Data based on characterization results, not tested in production.
2. Refer to Application Note AN1709 for data on other package types.

EMC CHARACTERISTICS (Cont'd)**12.7.3 Absolute Maximum Ratings (Electrical Sensitivity)**

Based on three different tests (ESD, LU and DLU) using specific measurement methods, the product is stressed in order to determine its performance in terms of electrical sensitivity. For more details, refer to the application note AN1181.

12.7.3.1 Electro-Static Discharge (ESD)

Electro-Static Discharges (a positive then a negative pulse separated by 1 second) are applied to the pins of each sample according to each pin combination. The sample size depends on the number of supply pins in the device (3 parts*(n+1) supply pin). Two models can be simulated: Human Body Model and Machine Model. This test conforms to the JESD22-A114A/A115A standard.

Absolute Maximum Ratings

Symbol	Ratings	Conditions	Maximum value ¹⁾	Unit
V _{ESD(HBM)}	Electro-static discharge voltage (Human Body Model)	T _A =+25°C	2000	V
V _{ESD(MM)}	Electro-static discharge voltage (Machine Model)	T _A =+25°C	200	

Notes:

1. Data based on characterization results, not tested in production.

12.7.3.2 Static and Dynamic Latch-Up

■ **LU:** 3 complementary static tests are required on 10 parts to assess the latch-up performance. A supply overvoltage (applied to each power supply pin) and a current injection (applied to each input, output and configurable I/O pin) are performed on each sample. This test conforms to the EIA/JESD 78 IC latch-up standard. For more details, refer to the application note AN1181.

■ **DLU:** Electro-Static Discharges (one positive then one negative test) are applied to each pin of 3 samples when the micro is running to assess the latch-up performance in dynamic mode. Power supplies are set to the typical values, the oscillator is connected as near as possible to the pins of the micro and the component is put in reset mode. This test conforms to the IEC1000-4-2 and SAEJ1752/3 standards. For more details, refer to the application note AN1181.

Electrical Sensitivities

Symbol	Parameter	Conditions	Class ¹⁾
LU	Static latch-up class	T _A =+25°C	A
		T _A =+85°C	A
		T _A =+125°C	A
DLU	Dynamic latch-up class	V _{DD} =5.5V, f _{OSC} =4MHz, T _A =+25°C	A

Notes:

1. Class description: A Class is an STMicroelectronics internal specification. All its limits are higher than the JEDEC specifications, that means when a device belongs to Class A it exceeds the JEDEC standard. B Class strictly covers all the JEDEC criteria (international standard).

12.8 I/O PORT PIN CHARACTERISTICS

12.8.1 General Characteristics

Subject to general operating conditions for V_{DD} , f_{OSC} , and T_A unless otherwise specified.

Symbol	Parameter	Conditions	Min	Typ	Max	Unit
V_{IL}	Input low level voltage ¹⁾	CMOS ports			$0.3 \times V_{DD}$	V
V_{IH}	Input high level voltage ¹⁾		$0.7 \times V_{DD}$			
V_{hys}	Schmitt trigger voltage hysteresis ²⁾			0.7		
V_{IL}	Input low level voltage ¹⁾	TTL ports			0.8	V
V_{IH}	Input high level voltage ¹⁾		2			
V_{hys}	Schmitt trigger voltage hysteresis ²⁾			1		
$I_{INJ(PIN)}^{3)}$	Injected Current on PC6 (Flash devices only)	$V_{DD}=5V$	0		+4	mA
	Injected Current on an I/O pin				± 4	
$\Sigma I_{INJ(PIN)}^{3)}$	Total injected current (sum of all I/O and control pins)				± 25	
I_L	Input leakage current	$V_{SS} \leq V_{IN} \leq V_{DD}$			± 1	μA
I_S	Static current consumption	Floating input mode ⁴⁾		400		
R_{PU}	Weak pull-up equivalent resistor ⁵⁾	$V_{IN}=V_{SS}$ $V_{DD}=5V$	50	120	250	k Ω
C_{IO}	I/O pin capacitance			5		pF
$t_{r(I/O)out}$	Output high to low level fall time ¹⁾	$C_L=50pF$ Between 10% and 90%		25		ns
$t_{r(I/O)out}$	Output low to high level rise time ¹⁾			25		
$t_{w(IT)in}$	External interrupt pulse time ⁶⁾		1			t_{CPU}

Figure 95. Unused I/O Pins configured as input

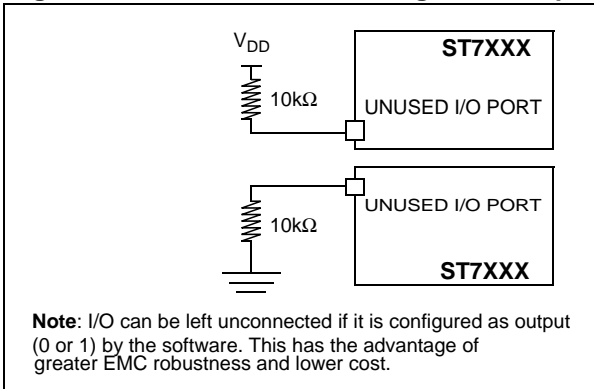
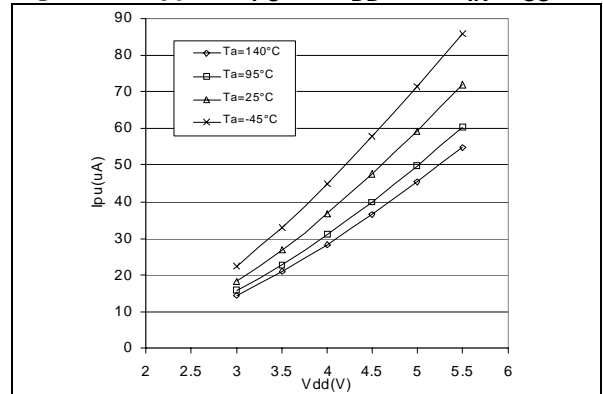

Figure 96. Typical I_{PU} vs. V_{DD} with $V_{IN}=V_{SS}$



Notes:

1. Data based on characterization results, not tested in production.
2. Hysteresis voltage between Schmitt trigger switching levels. Based on characterization results, not tested.
3. When the current limitation is not possible, the V_{IN} maximum must be respected, otherwise refer to $I_{INJ(PIN)}$ specification. A positive injection is induced by $V_{IN} > V_{DD}$ while a negative injection is induced by $V_{IN} < V_{SS}$. Refer to [section 12.2.2 on page 166](#) for more details.
4. Configuration not recommended, all unused pins must be kept at a fixed voltage: using the output mode of the I/O for example and leaving the I/O unconnected on the board or an external pull-up or pull-down resistor (see [Figure 95](#)). Data based on design simulation and/or technology characteristics, not tested in production.
5. The R_{PU} pull-up equivalent resistor is based on a resistive transistor (corresponding I_{PU} current characteristics described in [Figure 96](#)).
6. To generate an external interrupt, a minimum pulse width has to be applied on an I/O port pin configured as an external interrupt source.

I/O PORT PIN CHARACTERISTICS (Cont'd)

12.8.2 Output Driving Current

Subject to general operating conditions for V_{DD} , f_{CPU} , and T_A unless otherwise specified.

Symbol	Parameter	Conditions	Min	Max	Unit
$V_{OL}^{1)}$	Output low level voltage for a standard I/O pin when 8 pins are sunk at same time (see Figure 97)	$I_{IO}=+5mA$		1.2	V
		$I_{IO}=+2mA$		0.5	
	$I_{IO}=+20mA, T_A \leq 85^\circ C$ $T_A \geq 85^\circ C$		1.3		
			1.5		
$V_{OH}^{2)}$	Output high level voltage for an I/O pin when 4 pins are sourced at same time (see Figure 99 and Figure 102)	$I_{IO}=-5mA, T_A \leq 85^\circ C$ $T_A \geq 85^\circ C$	$V_{DD}-1.4$ $V_{DD}-1.6$		
		$I_{IO}=-8mA$		0.6	
		$I_{IO}=-2mA$	$V_{DD}-0.7$		

Figure 97. Typical V_{OL} at $V_{DD}=5V$ (standard)

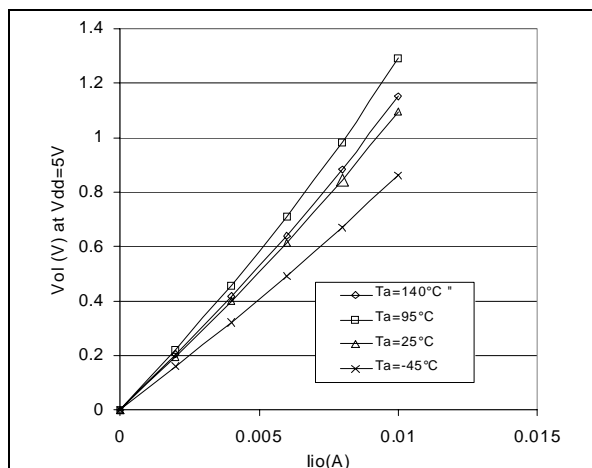

Figure 99. Typical V_{OH} at $V_{DD}=5V$

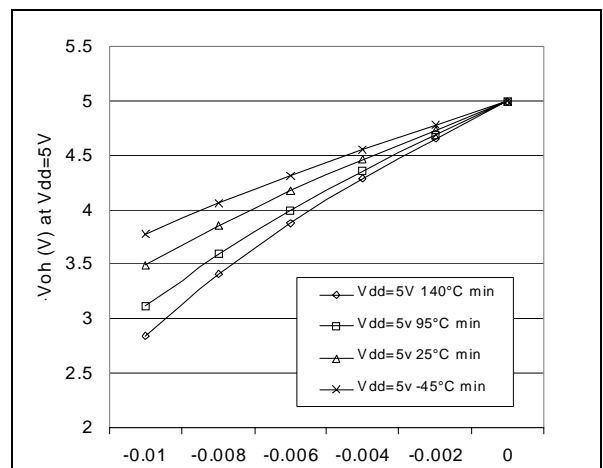
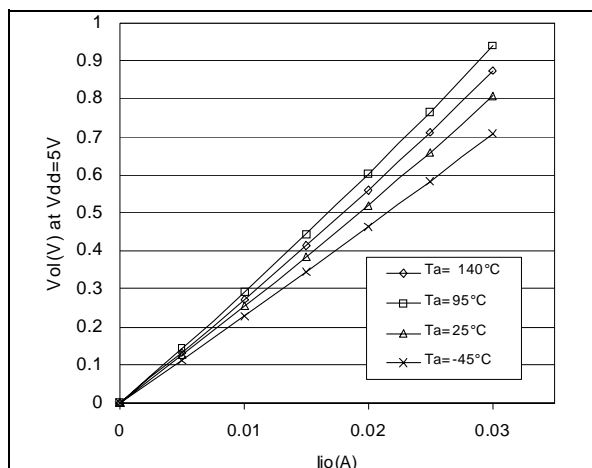

Figure 98. Typical V_{OL} at $V_{DD}=5V$ (high-sink)



Notes:

1. The I_{IO} current sunk must always respect the absolute maximum rating specified in Section 12.2.2 and the sum of I_{IO} (I/O ports and control pins) must not exceed I_{VSS} .
2. The I_{IO} current sourced must always respect the absolute maximum rating specified in Section 12.2.2 and the sum of I_{IO} (I/O ports and control pins) must not exceed I_{VDD} . True open drain I/O pins do not have V_{OH} .

I/O PORT PIN CHARACTERISTICS (Cont'd)

Figure 100. Typical V_{OL} vs. V_{DD} (standard)

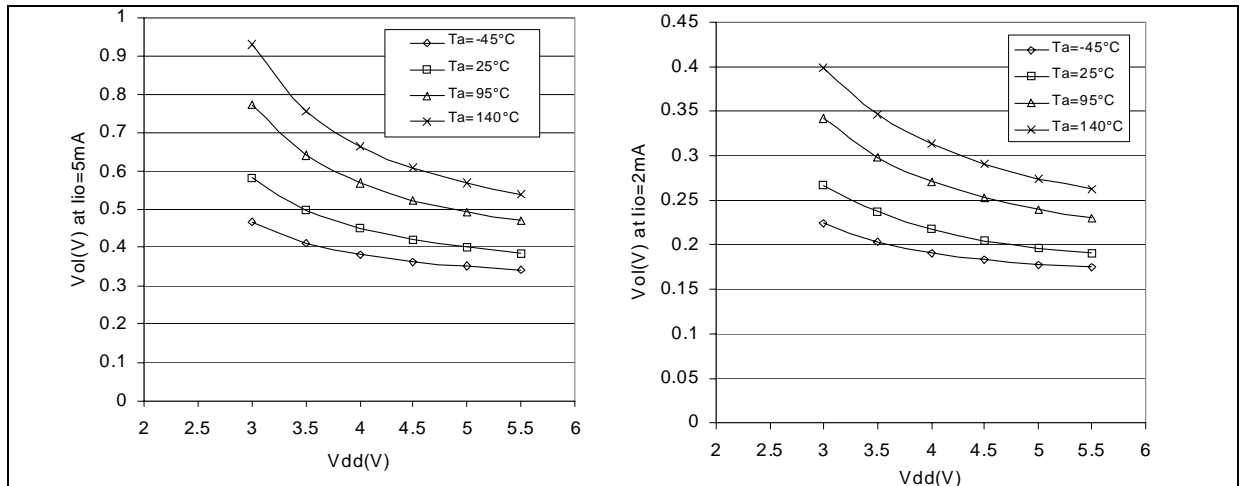

Figure 101. Typical V_{OL} vs. V_{DD} (high-sink)

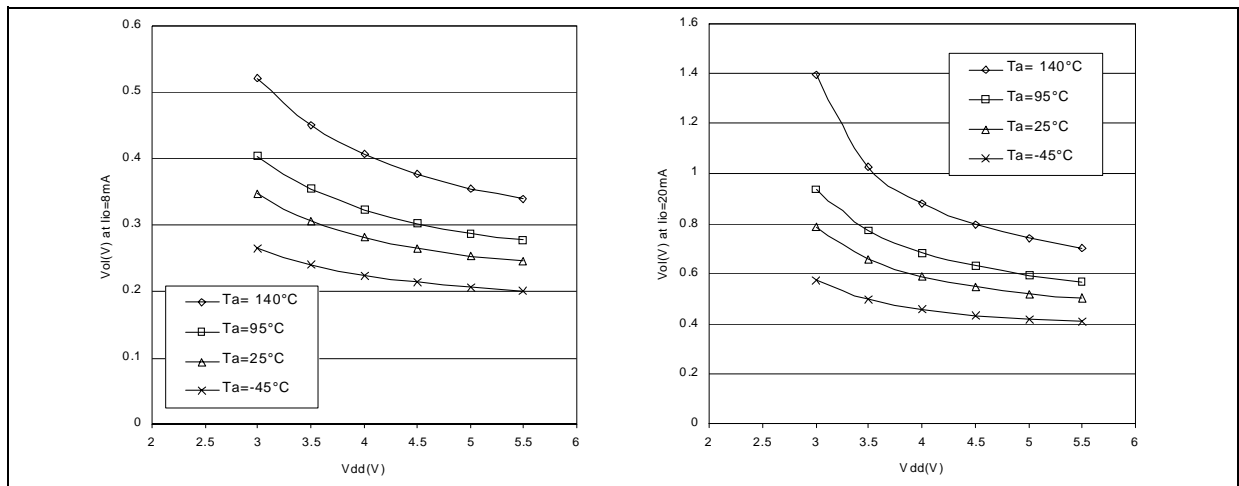
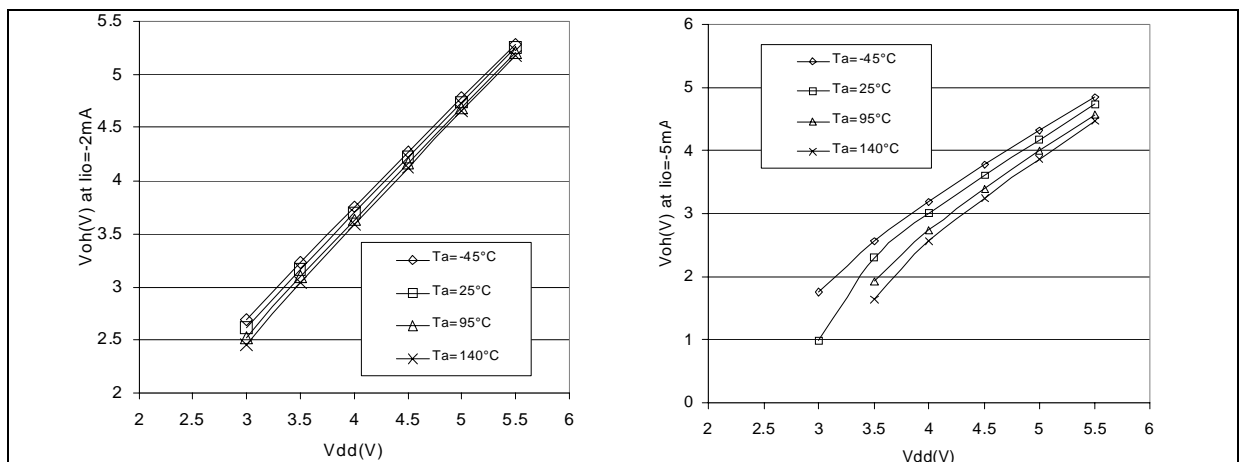

Figure 102. Typical $V_{DD}-V_{OH}$ vs. V_{DD}



12.9 CONTROL PIN CHARACTERISTICS

12.9.1 Asynchronous $\overline{\text{RESET}}$ Pin

Subject to general operating conditions for V_{DD} , f_{CPU} , and T_A unless otherwise specified.

Symbol	Parameter	Conditions	Min	Typ	Max	Unit
V_{IL}	Input low level voltage ¹⁾				$0.16 \times V_{DD}$	V
V_{IH}	Input high level voltage ¹⁾		$0.85 \times V_{DD}$			
V_{hys}	Schmitt trigger voltage hysteresis ²⁾			2.5		V
V_{OL}	Output low level voltage ³⁾	$V_{DD}=5V$ $I_{IO}=+2mA$		0.2	0.5	
I_{IO}	Input current on $\overline{\text{RESET}}$ pin			2		mA
R_{ON}	Weak pull-up equivalent resistor		20	30	120	k Ω
$t_{w(RSTL)out}$	Generated reset pulse duration	Stretch applied on external pulse	0		$42^{6)}$	μs
		Internal reset sources	20	30	$42^{6)}$	μs
$t_{h(RSTL)in}$	External reset pulse hold time ⁴⁾		2.5			μs
$t_{g(RSTL)in}$	Filtered glitch duration ⁵⁾			200		ns

Notes:

1. Data based on characterization results, not tested in production.
2. Hysteresis voltage between Schmitt trigger switching levels.
3. The I_{IO} current sunk must always respect the absolute maximum rating specified in [Section 12.2.2](#) and the sum of I_{IO} (I/O ports and control pins) must not exceed I_{VSS} .
4. To guarantee the reset of the device, a minimum pulse has to be applied to the $\overline{\text{RESET}}$ pin. All short pulses applied on the $\overline{\text{RESET}}$ pin with a duration below $t_{h(RSTL)in}$ can be ignored.
5. The reset network (the resistor and two capacitors) protects the device against parasitic resets, especially in noisy environments.
6. Data guaranteed by design, not tested in production.

CONTROL PIN CHARACTERISTICS (Cont'd)

Figure 103. $\overline{\text{RESET}}$ pin protection when LVD is enabled.¹⁾²⁾³⁾⁴⁾

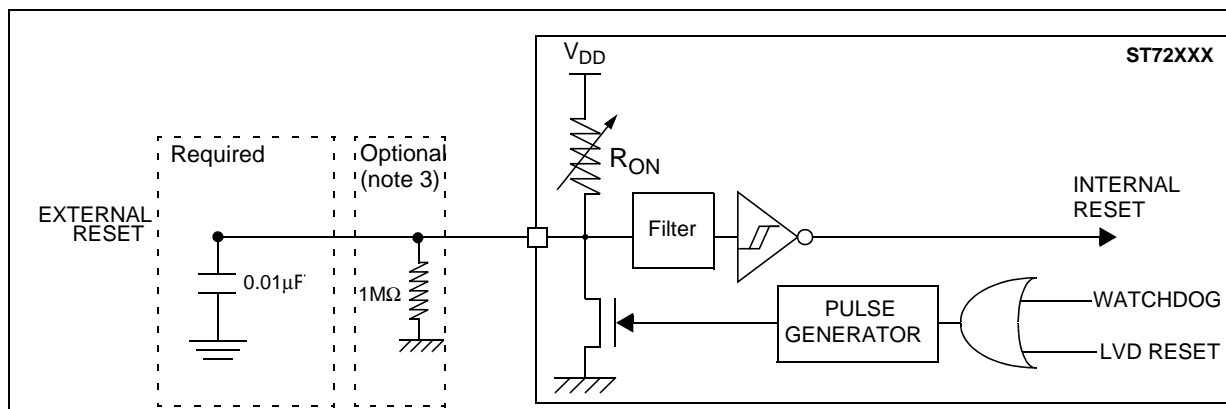
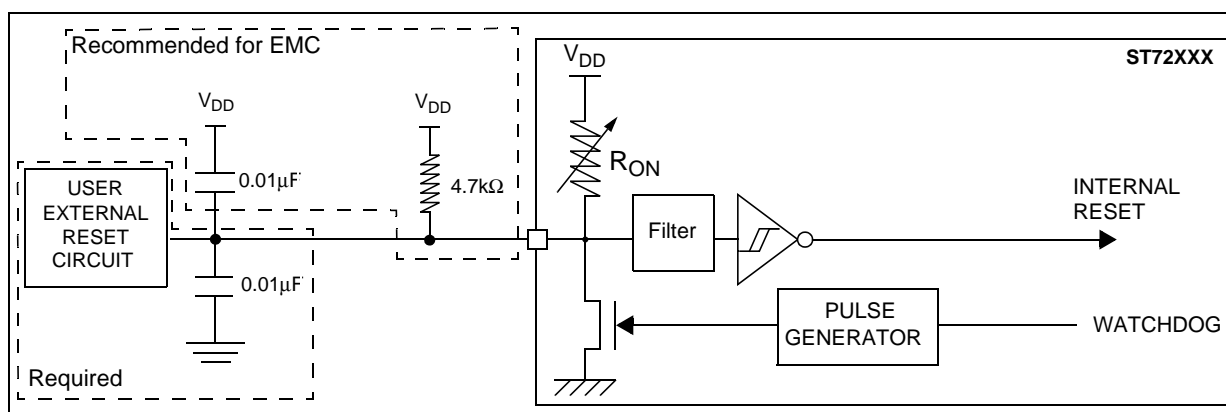

Figure 104. $\overline{\text{RESET}}$ pin protection when LVD is disabled.¹⁾



Note 1:

- The reset network protects the device against parasitic resets.
- The output of the external reset circuit must have an open-drain output to drive the ST7 reset pad. Otherwise the device can be damaged when the ST7 generates an internal reset (LVD or watchdog).
- Whatever the reset source is (internal or external), the user must ensure that the level on the $\overline{\text{RESET}}$ pin can go below the V_{IL} max. level specified in section 12.9.1 on page 185. Otherwise the reset will not be taken into account internally.
- Because the reset circuit is designed to allow the internal RESET to be output in the $\overline{\text{RESET}}$ pin, the user must ensure that the current sunk on the $\overline{\text{RESET}}$ pin is less than the absolute maximum value specified for $I_{INJ}(\overline{\text{RESET}})$ in section 12.2.2 on page 166.

Note 2: When the LVD is enabled, it is recommended not to connect a pull-up resistor or capacitor. A 10nF pull-down capacitor is required to filter noise on the reset line.

Note 3: In case a capacitive power supply is used, it is recommended to connect a 1MΩ pull-down resistor to the $\overline{\text{RESET}}$ pin to discharge any residual voltage induced by the capacitive effect of the power supply (this will add 5µA to the power consumption of the MCU).

Note 4: Tips when using the LVD:

- 1. Check that all recommendations related to reset circuit have been applied (see notes above).
- 2. Check that the power supply is properly decoupled (100nF + 10µF close to the MCU). Refer to AN1709 and AN2017. If this cannot be done, it is recommended to put a 100nF + 1MΩ pull-down on the $\overline{\text{RESET}}$ pin.
- 3. The capacitors connected on the RESET pin and also the power supply are key to avoid any start-up marginality. In most cases, steps 1 and 2 above are sufficient for a robust solution. Otherwise: replace 10nF pull-down on the $\overline{\text{RESET}}$ pin with a 5µF to 20µF capacitor.

CONTROL PIN CHARACTERISTICS (Cont'd)

12.9.2 ICCSEL/V_{PP} Pin

Subject to general operating conditions for V_{DD}, f_{CPU}, and T_A unless otherwise specified.

Symbol	Parameter	Conditions	Min	Max	Unit
V _{IL}	Input low level voltage ¹⁾	FLASH versions	V _{SS}	0.2	V
		ROM versions	V _{SS}	0.3xV _{DD}	
V _{IH}	Input high level voltage ¹⁾	FLASH versions	V _{DD} -0.1	12.6	
		ROM versions	0.7xV _{DD}	V _{DD}	
I _L	Input leakage current	V _{IN} =V _{SS}		±1	μA

Figure 105. Two typical Applications with ICCSEL/V_{PP} Pin ²⁾

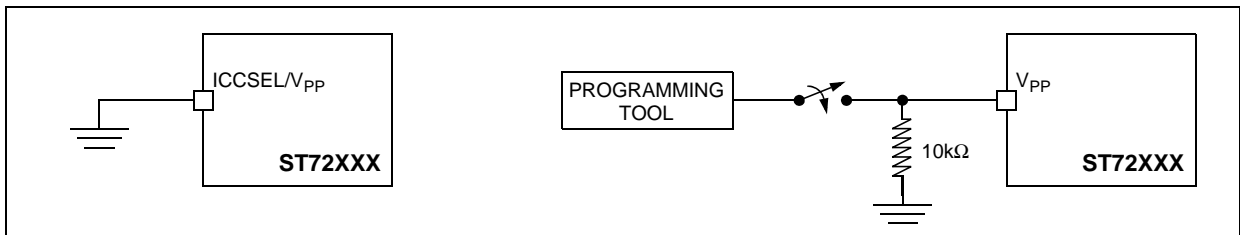

Notes:

1. Data based on design simulation and/or technology characteristics, not tested in production.
2. When ICC mode is not required by the application ICCSEL/V_{PP} pin must be tied to V_{SS}.

12.10 TIMER PERIPHERAL CHARACTERISTICS

Subject to general operating conditions for V_{DD} , f_{OSC} , and T_A unless otherwise specified.

Refer to I/O port characteristics for more details on the input/output alternate function characteristics (output compare, input capture, external clock, PWM output...).

12.10.1 8-Bit PWM-ART Auto-Reload Timer

Symbol	Parameter	Conditions	Min	Typ	Max	Unit
$t_{res(PWM)}$	PWM resolution time		1			t_{CPU}
		$f_{CPU}=8MHz$	125			ns
f_{EXT}	ART external clock frequency		0		$f_{CPU}/2$	MHz
f_{PWM}	PWM repetition rate		0		$f_{CPU}/2$	
Res_{PWM}	PWM resolution				8	bit
V_{OS}	PWM/DAC output step voltage	$V_{DD}=5V, Res=8-bits$		20		mV

12.10.2 16-Bit Timer

Symbol	Parameter	Conditions	Min	Typ	Max	Unit
$t_{w(ICAP)in}$	Input capture pulse time		1			t_{CPU}
$t_{res(PWM)}$	PWM resolution time		2			t_{CPU}
		$f_{CPU}=8MHz$	250			ns
f_{EXT}	Timer external clock frequency		0		$f_{CPU}/4$	MHz
f_{PWM}	PWM repetition rate		0		$f_{CPU}/4$	MHz
Res_{PWM}	PWM resolution				16	bit

12.11 COMMUNICATION INTERFACE CHARACTERISTICS

12.11.1 SPI - Serial Peripheral Interface

Subject to general operating conditions for V_{DD} , f_{CPU} , and T_A unless otherwise specified.

Refer to I/O port characteristics for more details on the input/output alternate function characteristics (\overline{SS} , SCK, MOSI, MISO).

Symbol	Parameter	Conditions	Min	Max	Unit
f_{SCK} $1/t_c(SCK)$	SPI clock frequency	Master $f_{CPU}=8MHz$	$f_{CPU}/128$ 0.0625	$f_{CPU}/4$ 2	MHz
		Slave $f_{CPU}=8MHz$	0	$f_{CPU}/2$ 4	
$t_r(SCK)$ $t_f(SCK)$	SPI clock rise and fall time		see I/O port pin description		
$t_{su}(\overline{SS})$	\overline{SS} setup time	Slave	120		ns
$t_h(\overline{SS})$	\overline{SS} hold time	Slave	120		
$t_w(SCKH)$ $t_w(SCKL)$	SCK high and low time	Master	100		
		Slave	90		
$t_{su}(MI)$ $t_{su}(SI)$	Data input setup time	Master	100		
		Slave	100		
$t_h(MI)$ $t_h(SI)$	Data input hold time	Master	100		
		Slave	100		
$t_a(SO)$	Data output access time	Slave	0	120	
$t_{dis}(SO)$	Data output disable time	Slave		240	
$t_v(SO)$	Data output valid time	Slave (after enable edge)		90	
$t_h(SO)$	Data output hold time		0		
$t_v(MO)$	Data output valid time	Master (before capture edge)	0.25		t_{CPU}
$t_h(MO)$	Data output hold time		0.25		

Figure 106. SPI Slave Timing Diagram with $CPHA=0$ ³⁾

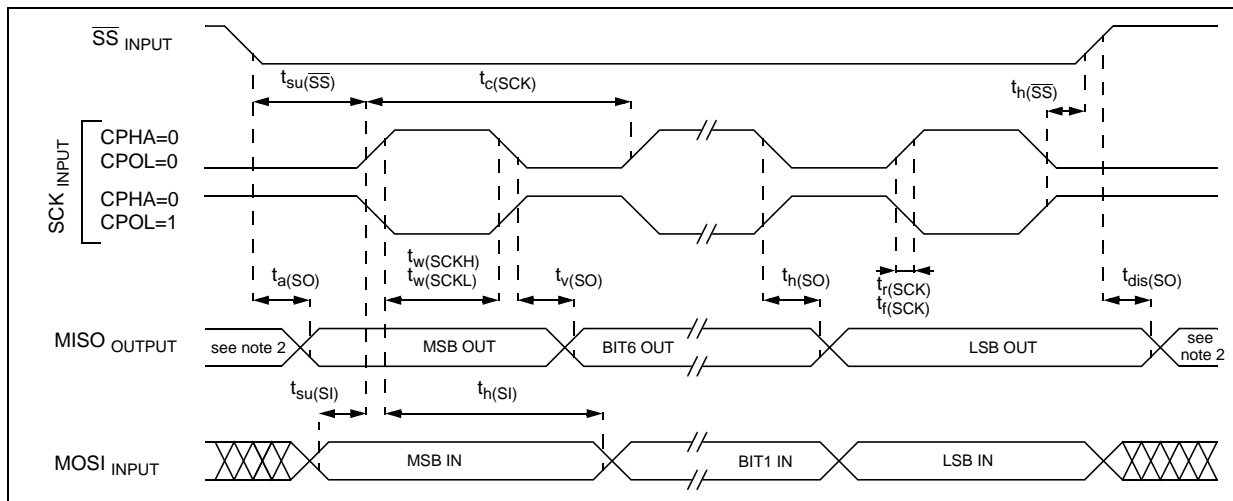

Notes:

1. Data based on design simulation and/or characterisation results, not tested in production.
2. When no communication is on-going the data output line of the SPI (MOSI in master mode, MISO in slave mode) has its alternate function capability released. In this case, the pin status depends on the I/O port configuration.
3. Measurement points are done at CMOS levels: $0.3xV_{DD}$ and $0.7xV_{DD}$.

COMMUNICATION INTERFACE CHARACTERISTICS (Cont'd)

Figure 107. SPI Slave Timing Diagram with CPHA=1¹⁾

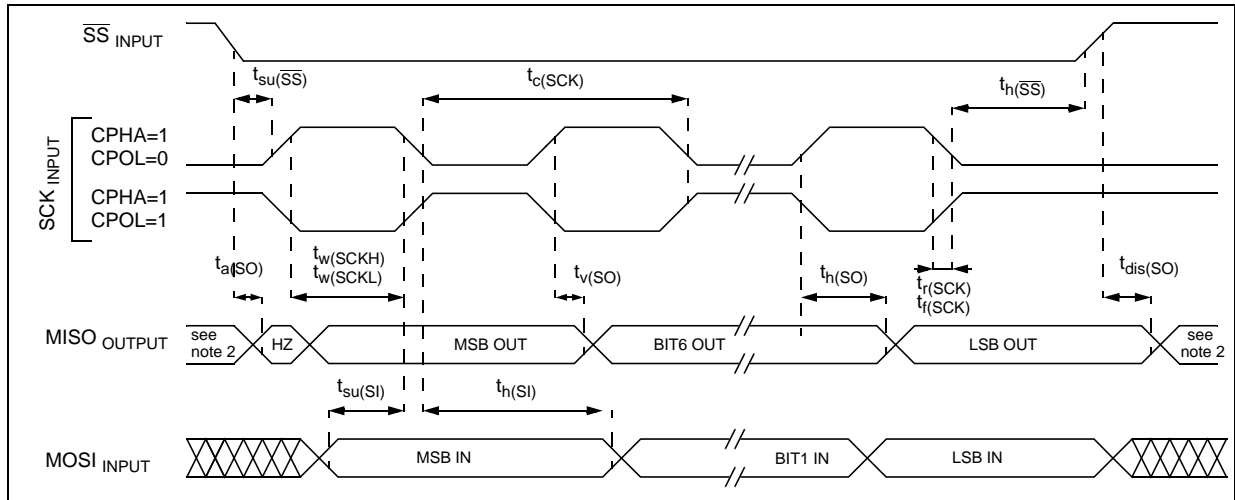
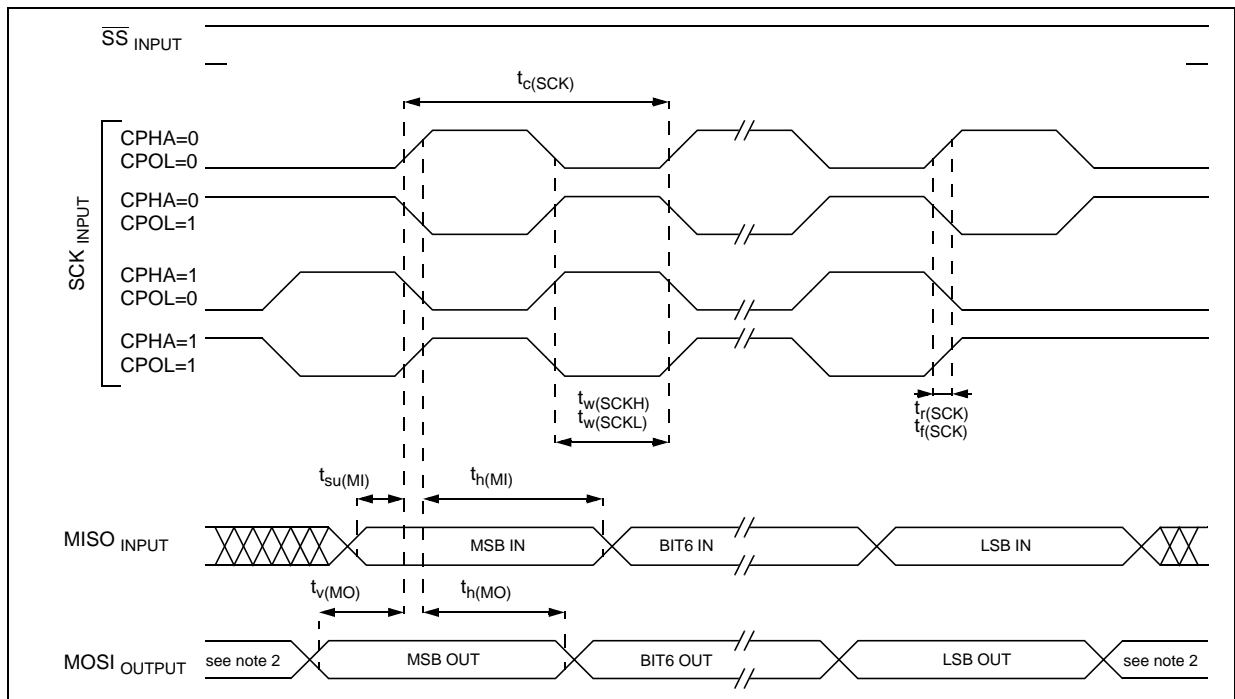

Figure 108. SPI Master Timing Diagram ¹⁾



Notes:

1. Measurement points are done at CMOS levels: $0.3xV_{DD}$ and $0.7xV_{DD}$.
2. When no communication is on-going the data output line of the SPI (MOSI in master mode, MISO in slave mode) has its alternate function capability released. In this case, the pin status depends of the I/O port configuration.

COMMUNICATION INTERFACE CHARACTERISTICS (Cont'd)

12.11.2 I²C - Inter IC Control Interface

Subject to general operating conditions for V_{DD}, f_{CPU}, and T_A unless otherwise specified.

Refer to I/O port characteristics for more details on the input/output alternate function characteristics (SDAI and SCLI). The ST7 I²C interface meets the requirements of the Standard I²C communication protocol described in the following table.

Symbol	Parameter	Standard mode I ² C		Fast mode I ² C ⁵⁾		Unit
		Min ¹⁾	Max ¹⁾	Min ¹⁾	Max ¹⁾	
t _w (SCLL)	SCL clock low time	4.7		1.3		μs
t _w (SCLH)	SCL clock high time	4.0		0.6		
t _{su} (SDA)	SDA setup time	250		100		ns
t _h (SDA)	SDA data hold time	0 ³⁾		0 ²⁾	900 ³⁾	
t _r (SDA) t _r (SCL)	SDA and SCL rise time		1000	20+0.1C _b	300	
t _f (SDA) t _f (SCL)	SDA and SCL fall time		300	20+0.1C _b	300	
t _h (STA)	START condition hold time	4.0		0.6		μs
t _{su} (STA)	Repeated START condition setup time	4.7		0.6		
t _{su} (STO)	STOP condition setup time	4.0		0.6		μs
t _w (STO:STA)	STOP to START condition time (bus free)	4.7		1.3		μs
C _b	Capacitive load for each bus line		400		400	pF

Figure 109. Typical Application with I²C Bus and Timing Diagram ⁴⁾

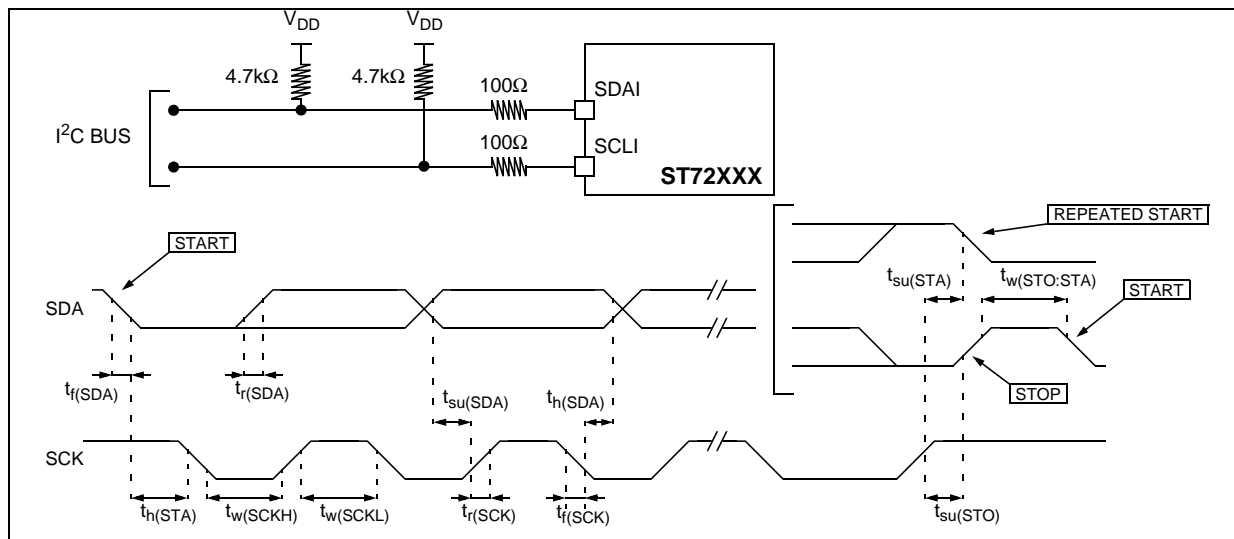

Notes:

1. Data based on standard I²C protocol requirement, not tested in production.
2. The device must internally provide a hold time of at least 300ns for the SDA signal in order to bridge the undefined region of the falling edge of SCL.
3. The maximum hold time of the START condition has only to be met if the interface does not stretch the low period of SCL signal.
4. Measurement points are done at CMOS levels: 0.3xV_{DD} and 0.7xV_{DD}.
5. At 4MHz f_{CPU}, max.I²C speed (400kHz) is not achievable. In this case, max. I²C speed will be approximately 260KHz.

COMMUNICATION INTERFACE CHARACTERISTICS (Cont'd)

The following table gives the values to be written in the I2CCCR register to obtain the required I²C SCL line frequency.

Table 28. SCL Frequency Table

f _{SCL} (kHz)	I2CCCR Value							
	f _{CPU} =4 MHz.				f _{CPU} =8 MHz.			
	V _{DD} = 4.1 V		V _{DD} = 5 V		V _{DD} = 4.1 V		V _{DD} = 5 V	
	R _p =3.3kΩ	R _p =4.7kΩ	R _p =3.3kΩ	R _p =4.7kΩ	R _p =3.3kΩ	R _p =4.7kΩ	R _p =3.3kΩ	R _p =4.7kΩ
400	NA	NA	NA	NA	83h	83	83h	83h
300	NA	NA	NA	NA	85h	85h	85h	85h
200	83h	83h	83h	83h	8Ah	89h	8Ah	8Ah
100	10h	10h	10h	10h	24h	23h	24h	23h
50	24h	24h	24h	24h	4Ch	4Ch	4Ch	4Ch
20	5Fh	5Fh	5Fh	5Fh	FFh	FFh	FFh	FFh

Legend:

R_p = External pull-up resistance

f_{SCL} = I²C speed

NA = Not achievable

Note:

- For speeds around 200 kHz, achieved speed can have ±5% tolerance
- For other speed ranges, achieved speed can have ±2% tolerance

The above variations depend on the accuracy of the external components used.

12.11.3 CAN - Controller Area Network Interface

Subject to general operating condition for V_{DD}, f_{OSC}, and T_A unless otherwise specified.

Refer to I/O port characteristics for more details on the input/output alternate function characteristics (CANTX and CANRX).

Symbol	Parameter	Conditions	Min	Typ	Max	Unit
t _{p(RX:TX)}	CAN controller propagation time ¹⁾				60	ns

Notes:

1. Data based on simulation results, not tested in production

12.12 10-BIT ADC CHARACTERISTICS

Subject to general operating conditions for V_{DD} , f_{CPU} , and T_A unless otherwise specified.

Symbol	Parameter	Conditions	Min	Typ	Max	Unit
f_{ADC}	ADC clock frequency		0.4		2	MHz
V_{AREF}	Analog reference voltage	$0.7 \cdot V_{DD} \leq V_{AREF} \leq V_{DD}$	3.8		V_{DD}	V
V_{AIN}	Conversion voltage range ¹⁾		V_{SSA}		V_{AREF}	
I_{Ikg}	Positive input leakage current for analog input	$-40^{\circ}\text{C} \leq T_A \leq 85^{\circ}\text{C}$ range			± 250	nA
		Other T_A ranges			± 1	μA
I_{Ikg}	Negative input leakage current on robust analog pins (ROM devices only) ²⁾	$V_{IN} < V_{SS}$, $ I_{IN} < 400\mu\text{A}$ on adjacent robust analog pin		5	6	μA
I_{Ikg}	Positive input leakage current for analog input	$-40^{\circ}\text{C} \leq T_A \leq 85^{\circ}\text{C}$ range			± 250	nA
		Other T_A ranges			± 1	μA
I_{Ikg}	Negative input leakage current on robust analog pins (ROM devices only) ²⁾	$V_{IN} < V_{SS}$, $ I_{IN} < 400\mu\text{A}$ on adjacent robust analog pin		5	6	μA
R_{AIN}	External input impedance				see	k Ω
C_{AIN}	External capacitor on analog input				Figure 110 and Figure 111 ²⁾³⁾⁴⁾	pF
f_{AIN}	Variation freq. of analog input signal					Hz
C_{ADC}	Internal sample and hold capacitor			12		pF
t_{ADC}	Conversion time (Sample+Hold) $f_{CPU}=8\text{MHz}$, $\text{SPEED}=0$ $f_{ADC}=2\text{MHz}$			7.5		μs
t_{ADC}	- No. of sample capacitor loading cycles - No. of Hold conversion cycles			4		$1/f_{ADC}$
				11		

Notes:

1. Any added external serial resistor will downgrade the ADC accuracy (especially for resistance greater than 10k Ω). Data based on characterization results, not tested in production.

2. For Flash devices: injecting negative current on any of the analog input pins significantly reduces the accuracy of any conversion being performed on any analog input. Analog pins of flash devices can be protected against negative injection by adding a Schottky diode (pin to ground). Injecting negative current on digital input pins degrades ADC accuracy especially if performed on a pin close to the analog input pins. Any positive injection current within the limits specified for $I_{INJ(PIN)}$ and $\Sigma I_{INJ(PIN)}$ in Section 12.8 does not affect the ADC accuracy.

ADC CHARACTERISTICS (Cont'd)

Figure 110. R_{AIN} max. vs f_{ADC} with $C_{AIN}=0pF^1)$

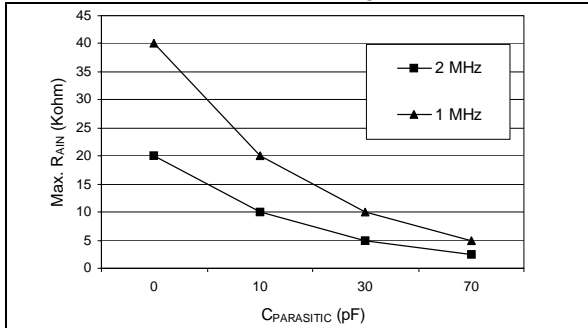

Figure 111. Recommended C_{AIN} & R_{AIN} values.²⁾

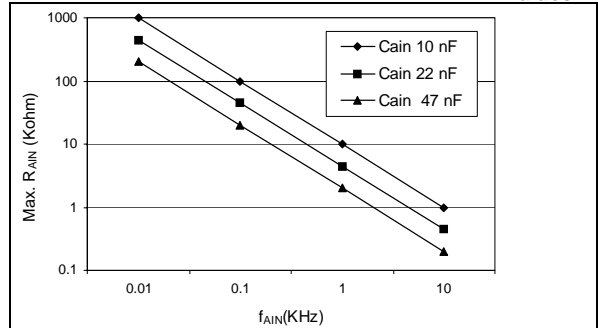
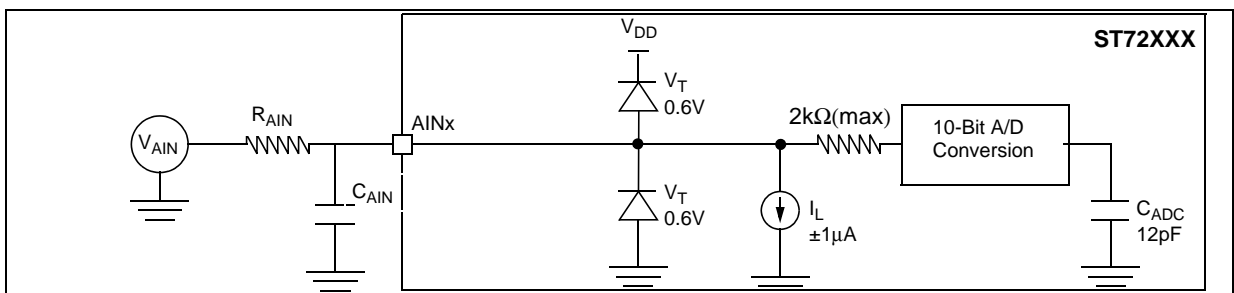

Figure 112. Typical A/D Converter Application



Notes:

1. $C_{PARASITIC}$ represents the capacitance of the PCB (dependent on soldering and PCB layout quality) plus the pad capacitance (3pF). A high $C_{PARASITIC}$ value will downgrade conversion accuracy. To remedy this, f_{ADC} should be reduced.
2. This graph shows that depending on the input signal variation (f_{AIN}), C_{AIN} can be increased for stabilization time and decreased to allow the use of a larger serial resistor (R_{AIN}).

ADC CHARACTERISTICS (Cont'd)

12.12.1 Analog Power Supply and Reference Pins

Depending on the MCU pin count, the package may feature separate V_{AREF} and V_{SSA} analog power supply pins. These pins supply power to the A/D converter cell and function as the high and low reference voltages for the conversion.

Separation of the digital and analog power pins allow board designers to improve A/D performance. Conversion accuracy can be impacted by voltage drops and noise in the event of heavily loaded or badly decoupled power supply lines (see [Section 12.12.2 General PCB Design Guidelines](#)).

12.12.2 General PCB Design Guidelines

To obtain best results, some general design and layout rules should be followed when designing the application PCB to shield the noise-sensitive, analog physical interface from noise-generating CMOS logic signals.

- Use separate digital and analog planes. The analog ground plane should be connected to the digital ground plane via a single point on the PCB.

- Filter power to the analog power planes. It is recommended to connect capacitors, with good high frequency characteristics, between the power and ground lines, placing $0.1\mu\text{F}$ and optionally, if needed 10pF capacitors as close as possible to the ST7 power supply pins and a 1 to $10\mu\text{F}$ capacitor close to the power source (see [Figure 113](#)).
- The analog and digital power supplies should be connected in a star network. Do not use a resistor, as V_{AREF} is used as a reference voltage by the A/D converter and any resistance would cause a voltage drop and a loss of accuracy.
- Properly place components and route the signal traces on the PCB to shield the analog inputs. Analog signals paths should run over the analog ground plane and be as short as possible. Isolate analog signals from digital signals that may switch while the analog inputs are being sampled by the A/D converter. Do not toggle digital outputs on the same I/O port as the A/D input being converted.

Figure 113. Power Supply Filtering

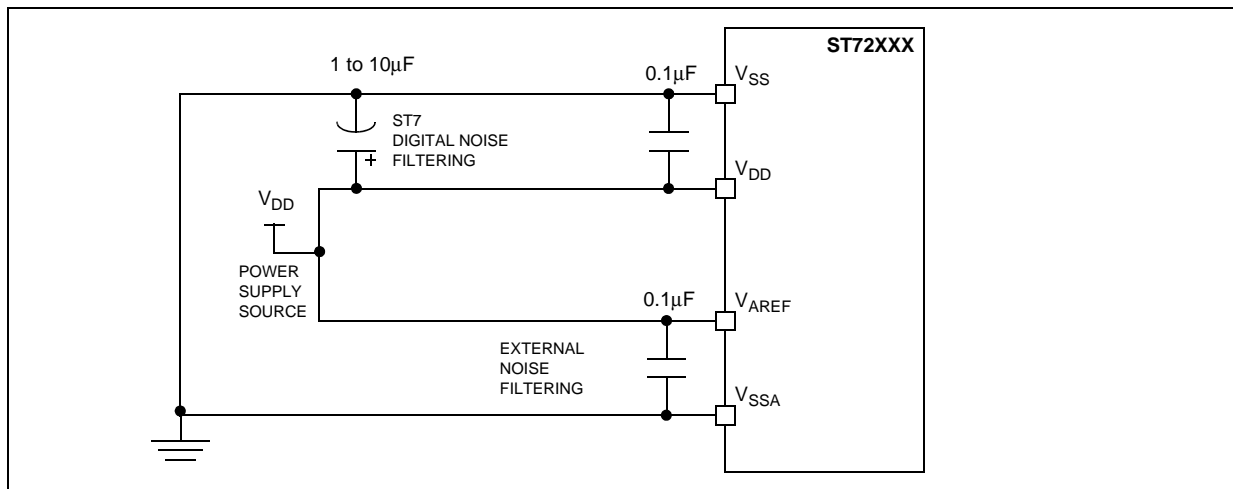

10-BIT ADC CHARACTERISTICS (Cont'd)

12.12.3 ADC Accuracy

Conditions: $V_{DD}=5V$ ¹⁾

Symbol	Parameter	Conditions	Typ	Max ²⁾	Unit
$ E_T $	Total unadjusted error ¹⁾		3	4	LSB
$ E_O $	Offset error ¹⁾		2	3	
$ E_G $	Gain Error ¹⁾		0.5	3	
$ E_D $	Differential linearity error ¹⁾	CPU in run mode @ f_{ADC} 2 MHz.	1	2	
$ E_L $	Integral linearity error ¹⁾	CPU in run mode @ f_{ADC} 2 MHz.	1	2	

Notes:

1. ADC Accuracy vs. Negative Injection Current: Injecting negative current may reduce the accuracy of the conversion being performed on another analog input. The effect of negative injection current on robust pins is specified in Section 12.12.

Any positive injection current within the limits specified for $I_{INJ(PIN)}$ and $\Sigma I_{INJ(PIN)}$ in Section 12.8 does not affect the ADC accuracy.

2. Data based on characterization results, monitored in production to guarantee 99.73% within \pm max value from -40°C to 125°C ($\pm 3\sigma$ distribution limits).

Figure 114. ADC Accuracy Characteristics

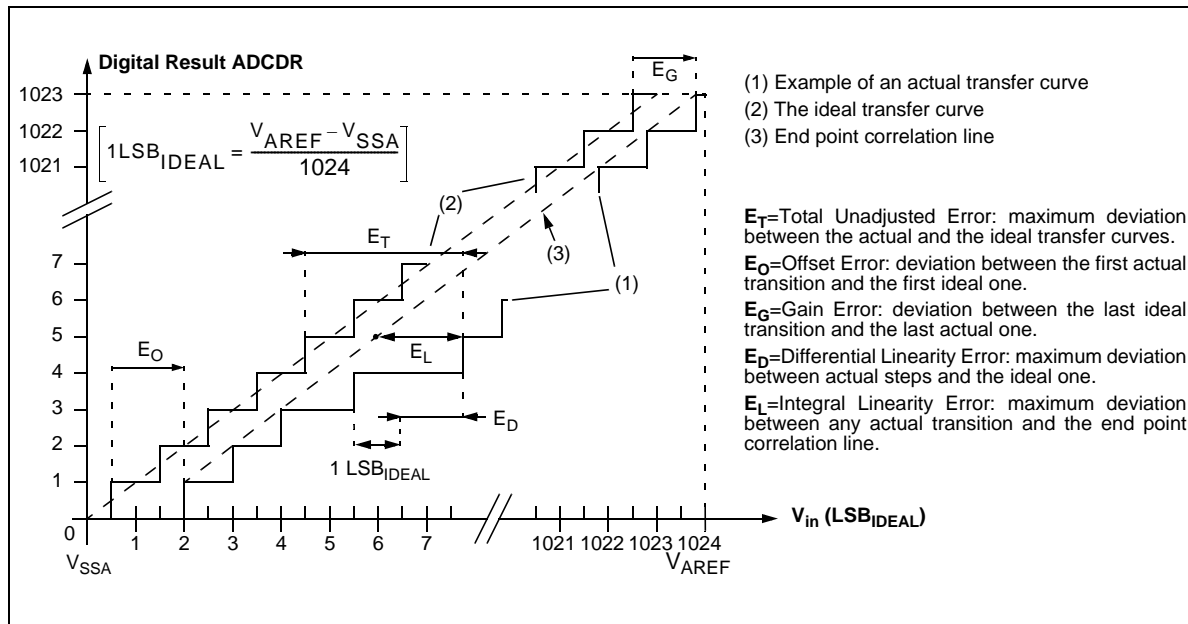

13 PACKAGE CHARACTERISTICS

13.1 PACKAGE MECHANICAL DATA

Figure 115. 80-Pin Thin Quad Flat Package

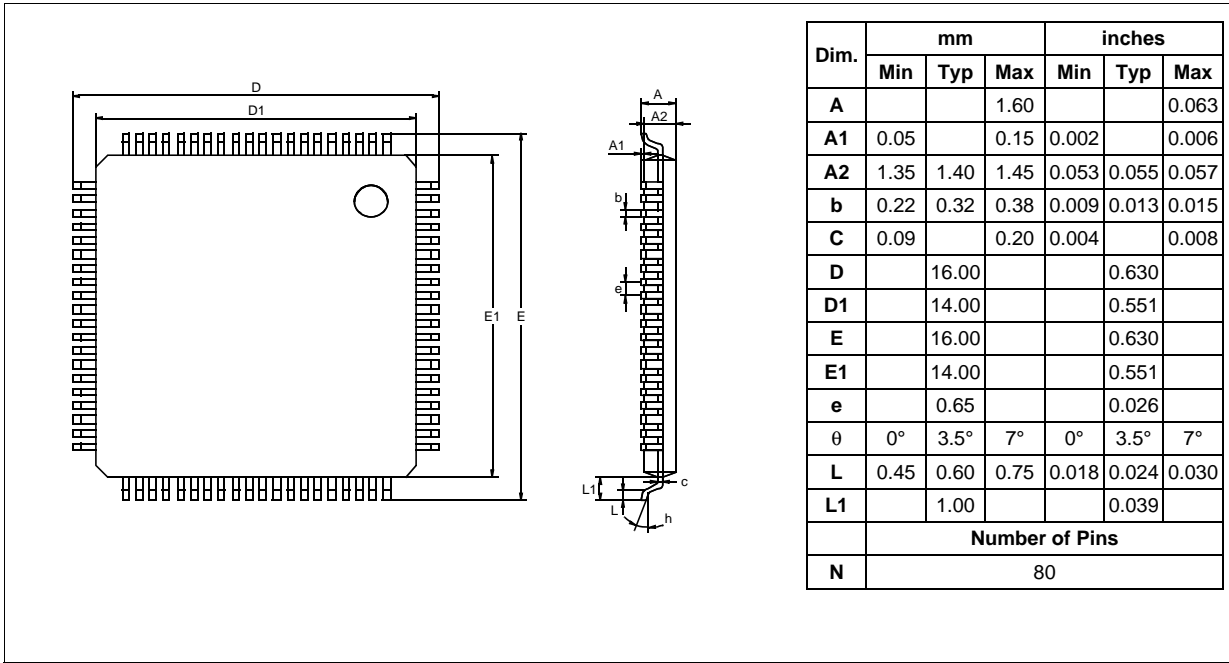
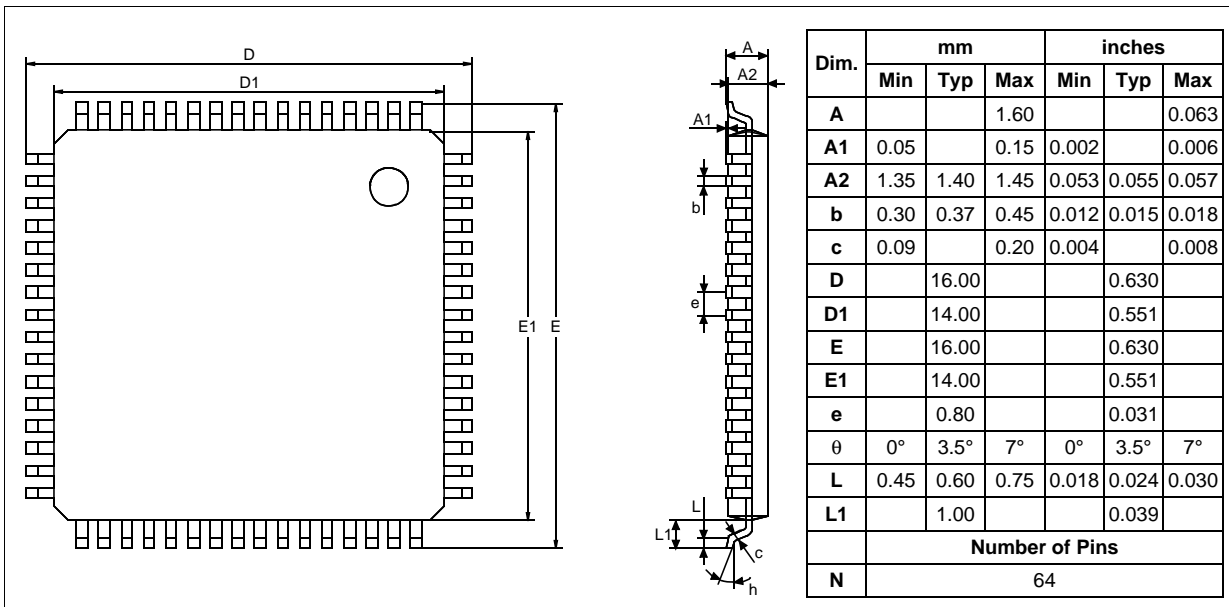
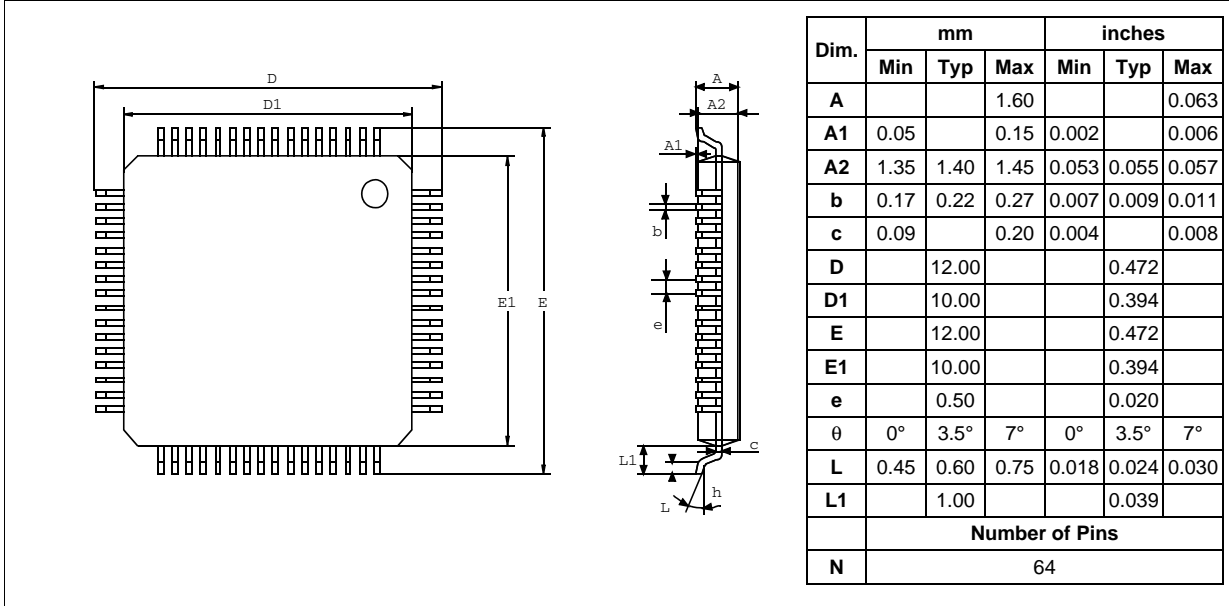

Figure 116. 64-Pin Thin Quad Flat Package



PACKAGE MECHANICAL DATA (Cont'd)

Figure 117. 64-Pin Thin Quad Flat Package



13.2 THERMAL CHARACTERISTICS

Symbol	Ratings	Value	Unit
R_{thJA}	Package thermal resistance (junction to ambient)		
	TQFP80 14x14	55	°C/W
	TQFP64 14x14	47	
	TQFP64 10x10	50	
P_D	Power dissipation ¹⁾	500	mW
T_{Jmax}	Maximum junction temperature ²⁾	150	°C

Notes:

1. The power dissipation is obtained from the formula $P_D = P_{INT} + P_{PORT}$ where P_{INT} is the chip internal power ($I_{DD} \times V_{DD}$) and P_{PORT} is the port power dissipation determined by the user.
2. The average chip-junction temperature can be obtained from the formula $T_J = T_A + P_D \times R_{thJA}$.

13.3 SOLDERING INFORMATION

In accordance with the RoHS European directive, all STMicroelectronics packages will be converted in 2005 to lead-free technology, named ECOPACK™ (for a detailed roadmap, please refer to PCN CRP/04/744 "Lead-free Conversion Program - Compliance with RoHS", issued November 18th, 2004).

- ECOPACK™ packages are qualified according to the JEDEC STD-020B compliant soldering profile.
- Detailed information on the STMicroelectronic ECOPACK™ transition program is available on www.st.com/stonline/leadfree/, with specific technical Application notes covering the main technical aspects related to lead-free conversion (AN2033, AN2034, AN2035, AN2036).

Backward and forward compatibility:

The main difference between Pb and Pb-free soldering process is the temperature range.

- ECOPACK™ TQFP packages are fully compatible with Lead (Pb) containing soldering process (see application note AN2034)
- TQFP Pb-packages are compatible with Lead-free soldering process, nevertheless it's the customer's duty to verify that the Pb-packages maximum temperature (mentioned on the Inner box label) is compatible with their Lead-free soldering temperature.

Table 29. Soldering Compatibility (wave and reflow soldering process)

Package	Plating material devices	Pb solder paste	Pb-free solder paste
TQFP	NiPdAu (Nickel-palladium-Gold)	Yes	Yes *

* Assemblers must verify that the Pb-package maximum temperature (mentioned on the Inner box label) is compatible with their Lead-free soldering process.

14 ST72521 DEVICE CONFIGURATION AND ORDERING INFORMATION

Each device is available for production in user programmable versions (FLASH) as well as in factory coded versions (ROM/FASTROM).

ST72521B devices are ROM versions. ST72P521 devices are Factory Advanced Service Technique ROM (FASTROM) versions: they are factory-programmed HDFlash devices. FLASH devices are

shipped to customers with a default content, while ROM/FASTROM factory coded parts contain the code supplied by the customer. This implies that FLASH devices have to be configured by the customer using the Option Bytes while the ROM/FASTROM devices are factory-configured.

14.1 FLASH OPTION BYTES

	STATIC OPTION BYTE 0								STATIC OPTION BYTE 1							
	7		Res.	VD		Reserved	PKG0	FMP_R	PKG1	RSTC	OSCTYPE		OSCRANGE			PLLOFF
	HALT	SW		1	0						1	0	2	1	0	
Default	1	1	1	0	0	1	1	1	1	1	1	0	1	1	1	1

The option bytes allow the hardware configuration of the microcontroller to be selected. They have no address in the memory map and can be accessed only in programming mode (for example using a standard ST7 programming tool). The default content of the FLASH is fixed to FFh. To program the FLASH devices directly using ICP, FLASH devices are shipped to customers with the internal RC clock source. In masked ROM devices, the option bytes are fixed in hardware by the ROM code (see option list).

OPTION BYTE 0

OPT7= **WDG HALT** *Watchdog and HALT mode*

This option bit determines if a RESET is generated when entering HALT mode while the Watchdog is active.

0: No Reset generation when entering Halt mode
1: Reset generation when entering Halt mode

OPT6= **WDG SW** *Hardware or software watchdog*

This option bit selects the watchdog type.
0: Hardware (watchdog always enabled)

1: Software (watchdog to be enabled by software)

OPT5 = Reserved, must be kept at default value.

OPT4:3= **VD[1:0]** *Voltage detection*

These option bits enable the voltage detection block (LVD, and AVD) with a selected threshold for the LVD and AVD (EVD+AVD).

Selected Low Voltage Detector	VD1	VD0
LVD and AVD Off	1	1
Lowest Threshold: ($V_{DD} \sim 3V$)	1	0
Med. Threshold ($V_{DD} \sim 3.5V$)	0	1
Highest Threshold ($V_{DD} \sim 4V$)	0	0

Caution: If the medium or low thresholds are selected, the detection may occur outside the specified operating voltage range. Below 3.8V, device operation is not guaranteed. For details on the AVD and LVD threshold levels refer to [section 12.3.2 on page 168](#)

ST72521 DEVICE CONFIGURATION AND ORDERING INFORMATION (Cont'd)

OPT2 = Reserved, must be kept at default value.

OPT1= **PKG0** *Package selection bit 0*
 This option bit is used to select the package (see table in PKG1 option bit description).

OPT0= **FMP_R** *Flash memory read-out protection*
 Read-out protection, when selected, provides a protection against Program Memory content extraction and against write access to Flash memory.

Erasing the option bytes when the FMP_R option is selected causes the whole user memory to be erased first, and the device can be reprogrammed. Refer to [Section 4.3.1](#) and the ST7 Flash Programming Reference Manual for more details.

Note: Readout protection is not supported if LVD is enabled.

- 0: Read-out protection enabled
- 1: Read-out protection disabled

OPTION BYTE 1

OPT7= **PKG1** *Package selection bit 1*
 This option bit, with the PKG0 bit, selects the package.

Version	Selected Package	PKG 1	PKG 0
M	TQFP80	1	1
(A)R	TQFP64	1	0

Note: On the chip, each I/O port has 8 pads. Pads that are not bonded to external pins are in input pull-up configuration after reset. The configuration of these pads must be kept at reset state to avoid added current consumption.

OPT6 = **RSTC** *RESET clock cycle selection*
 This option bit selects the number of CPU cycles applied during the RESET phase and when exiting HALT mode. For resonator oscillators, it is advised to select 4096 due to the long crystal stabilization time.

- 0: Reset phase with 4096 CPU cycles
- 1: Reset phase with 256 CPU cycles

OPT5:4 = **OSCTYPE[1:0]** *Oscillator Type*
 These option bits select the ST7 main clock source type.

Clock Source	OSCTYPE	
	1	0
Resonator Oscillator	0	0
Reserved	0	1
Internal RC Oscillator	1	0
External Source	1	1

OPT3:1 = **OSCRANGE[2:0]** *Oscillator range*
 When the resonator oscillator type is selected, these option bits select the resonator oscillator current source corresponding to the frequency range of the used resonator. Otherwise, these bits are used to select the normal operating frequency range.

Typ. Freq. Range		OSCRANGE		
		2	1	0
LP	1~2MHz	0	0	0
MP	2~4MHz	0	0	1
MS	4~8MHz	0	1	0
HS	8~16MHz	0	1	1

OPT0 = **PLLOFF** *PLL activation*
 This option bit activates the PLL which allows multiplication by two of the main input clock frequency. The PLL must not be used with the internal RC oscillator or with external clock source. The PLL is guaranteed only with an input frequency between 2 and 4MHz.

- 0: PLL x2 enabled
- 1: PLL x2 disabled

CAUTION: the PLL can be enabled only if the "OSC RANGE" (OPT3:1) bits are configured to "MP - 2~4MHz". Otherwise, the device functionality is not guaranteed.

ST72521 DEVICE CONFIGURATION AND ORDERING INFORMATION (Cont'd)

14.2 DEVICE ORDERING INFORMATION AND TRANSFER OF CUSTOMER CODE

Customer code is made up of the ROM/FASTROM contents and the list of the selected options (if any). The ROM/FASTROM contents are to be sent on diskette, or by electronic means, with the S19 hexadecimal file generated by the development tool. All unused bytes must be set to FFh.

The selected options are communicated to STMicroelectronics using the correctly completed OPTION LIST appended.

Refer to application note AN1635 for information on the counter listing returned by ST after code has been transferred.

The STMicroelectronics Sales Organization will be pleased to provide detailed information on contractual points.

14.2.1 Version-Specific Sales Conditions

To satisfy the different customer requirements and to ensure that ST Standard Microcontrollers will consistently meet or exceed the expectations of each Market Segment, the Codification System for Standard Microcontrollers clearly distinguishes products intended for use in automotive environments, from products intended for use in non-automotive environments.

It is the responsibility of the Customer to select the appropriate product for his application.

Figure 118. ROM Factory Coded Device Types

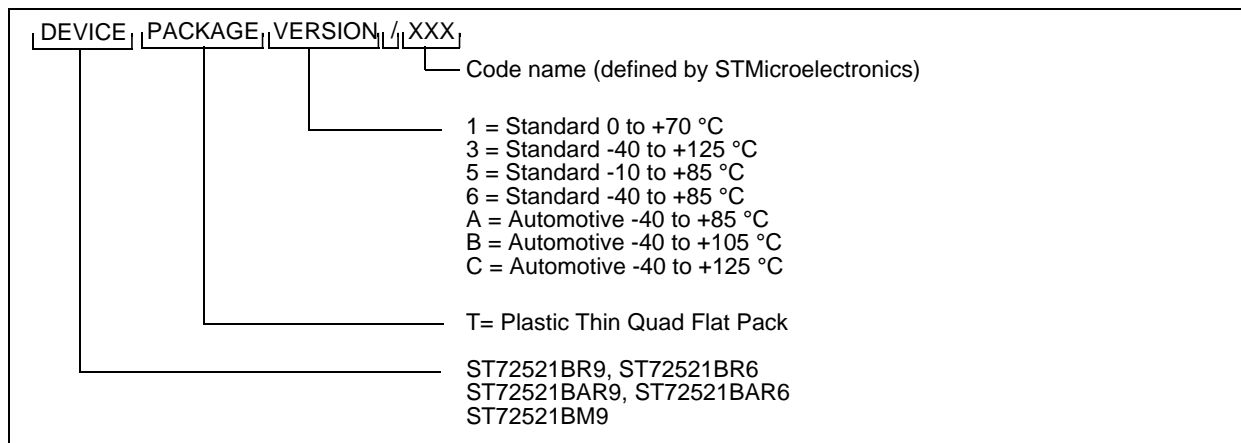

ST72521 DEVICE CONFIGURATION AND ORDERING INFORMATION (Cont'd)

ST72521B MICROCONTROLLER OPTION LIST		
(Last update: December 2004)		
Customer:	
Address:	
Contact:	
Phone No:	
Reference/ROM Code* :	
*The ROM code name is assigned by STMicroelectronics.		
ROM code must be sent in .S19 format. .Hex extension cannot be processed.		
Device Type/Memory Size/Package (check only one option):		
ROM DEVICE:	60K	32K
TQFP80:	<input type="checkbox"/> ST72521BM9	
TQFP64 14x14:	<input type="checkbox"/> ST72521BR9	<input type="checkbox"/> ST72521BR6
TQFP64 10x10:	<input type="checkbox"/> ST72521BAR9	<input type="checkbox"/> ST72521BAR6
DIE FORM:	60K	32K
80-pin:	<input type="checkbox"/>	
64-pin:	<input type="checkbox"/>	<input type="checkbox"/>
Conditioning (check only one option):		
Packaged Product		Die Product (dice tested at 25°C only)
<input type="checkbox"/> Tape & Reel	<input type="checkbox"/> Tray	<input type="checkbox"/> Tape & Reel
		<input type="checkbox"/> Inked wafer
		<input type="checkbox"/> Sawn wafer on sticky foil
Version/ Temp. Range (do not check for die product). Please refer to datasheet for specific sales conditions:		
Standard	Automotive	Temp. Range
<input type="checkbox"/>		<input type="checkbox"/> 0°C to +70°C
<input type="checkbox"/>		<input type="checkbox"/> -10°C to +85°C
<input type="checkbox"/>	<input type="checkbox"/>	<input type="checkbox"/> -40°C to +85°C
	<input type="checkbox"/>	<input type="checkbox"/> -40°C to +105°C
	<input type="checkbox"/>	<input type="checkbox"/> -40°C to +125°C
Special Marking: <input type="checkbox"/> No <input type="checkbox"/> Yes "_____ " (10 char. max)		
Authorized characters are letters, digits, '.', '-', '/' and spaces only.		
Clock Source Selection:		
<input type="checkbox"/> Resonator: <input type="checkbox"/> LP: Low power resonator (1 to 2 MHz)		
<input type="checkbox"/> MP: Medium power resonator (2 to 4 MHz)		
<input type="checkbox"/> MS: Medium speed resonator (4 to 8 MHz)		
<input type="checkbox"/> HS: High speed resonator (8 to 16 MHz)		
<input type="checkbox"/> Internal RC:		
<input type="checkbox"/> External Clock		
PLL	<input type="checkbox"/> Disabled	<input type="checkbox"/> Enabled
LVD Reset	<input type="checkbox"/> Disabled	<input type="checkbox"/> High threshold <input type="checkbox"/> Med. threshold <input type="checkbox"/> Low threshold
Reset Delay	<input type="checkbox"/> 256 Cycles	<input type="checkbox"/> 4096 Cycles
Watchdog Selection:	<input type="checkbox"/> Software Activation	<input type="checkbox"/> Hardware Activation
Watchdog Reset on Halt:	<input type="checkbox"/> Reset	<input type="checkbox"/> No Reset
Readout Protection:	<input type="checkbox"/> Disabled	<input type="checkbox"/> Enabled
Date	
Signature	
Please download the latest version of this option list from:		
http://www.st.com/mcu > downloads > ST7 microcontrollers > Option list		

DEVICE CONFIGURATION AND ORDERING INFORMATION (Cont'd)

Table 30. Orderable Flash Device Types

Part Number	Version	Package	Flash Memory (Kbytes)	Temp. Range
ST72F521AR6TC	Automotive	TQFP64 10 x 10	32	-40°C +125°C
ST72F521AR9TC			60	
ST72F521R6TC		TQFP64 14 x 14	32	
ST72F521R9TC			60	
ST72F521M9TC		TQFP80	60	
ST72F521AR6T3	Standard	TQFP64 10 x 10	32	-40°C +125°C
ST72F521AR9T3			60	
ST72F521R6T3		TQFP64 14 x 14	32	
ST72F521R9T3			60	
ST72F521M9T3		TQFP80	60	
ST72F521AR6T6	Standard	TQFP64 10 x 10	32	-40°C +85°C
ST72F521AR9T6			60	
ST72F521R6T6		TQFP64 14 x 14	32	
ST72F521R9T6			60	
ST72F521M9T6		TQFP80	60	

DEVICE CONFIGURATION AND ORDERING INFORMATION (Cont'd)

14.3 DEVELOPMENT TOOLS

STMicroelectronics offers a range of hardware and software development tools for the ST7 micro-controller family. Full details of tools available for the ST7 from third party manufacturers can be obtained from the STMicroelectronics Internet site: <http://www.st.com>.

Tools from these manufacturers include C compilers, evaluation tools, emulators and programmers.

Emulators

Two types of emulators are available from ST for the ST725 family:

- **ST7 DVP3** entry-level emulator offers a flexible and modular debugging and programming solution. SDIP42 & SDIP32 probes/adapters are included, other packages need a specific connection kit (refer to [Table 31](#))
- **ST7 EMU3** high-end emulator is delivered with everything (probes, TEB, adapters etc.) needed to start emulating the ST725. To configure it to emulate other ST7 subfamily devices, the active probe for the ST7EMU3 can be changed and the ST7EMU3 probe is designed for easy interchange of TEBs (Target Emulation Board). See [Table 31](#).

In-circuit Debugging Kit

Two configurations are available from ST:

- **STXF521-IND/USB**: Low-cost In-Circuit Debugging kit from Softec Microsystems. Includes STX-InDART/USB board (USB port)

and a specific demo board for ST72521 (TQFP64)

- **STxF-INDART**

Flash Programming tools

- **ST7-STICK** ST7 In-circuit Communication Kit, a complete software/hardware package for programming ST7 Flash devices. It connects to a host PC parallel port and to the target board or socket board via ST7 ICC connector.
- **ICC Socket Boards** provide an easy to use and flexible means of programming ST7 Flash devices. They can be connected to any tool that supports the ST7 ICC interface, such as ST7 EMU3, ST7-DVP3, inDART, ST7-STICK, or many third-party development tools.

Evaluation boards

Three different Evaluation boards are available:

- **ST7232x-EVAL** ST72F321/325/521 evaluation board, with ICC connector for programming capability. Provides direct connection to ST7-DVP3 emulator. Supplied with daughter boards (core module) for ST72F321, ST72F324, ST72325 & ST72F521 (the ST72F32x chips are not included)
- **ST7MDT20-EVC/xx¹** with CAB TQFP64 14x14 socket
- **ST7MDT20-EVY/xx¹** with Yamaichi TQFP64 10x10 socket

Table 31. STMicroelectronics Development Tools

Supported Products	Emulation				Programming ICC Socket Board
	ST7 DVP3 Series		ST7 EMU3 series		
	Emulator	Connection kit	Emulator	Active Probe & T.E.B.	
ST72521M, ST72F521M	ST7MDT20-DVP3	ST7MDT20-T80/ DVP	ST7MDT20M- EMU3	ST7MDT20M-TEB	ST7SB20M/xx ¹
ST72521AR, ST72F521AR		ST7MDT20-T6A/ DVP			
ST72521R, ST72F521R		ST7MDT20-T64/ DVP			

Note 1: Add suffix /EU, /UK, /US for the power supply of your region.

DEVICE CONFIGURATION AND ORDERING INFORMATION (Cont'd)
Table 32. Suggested List of Socket Types

Device	Socket (supplied with ST7MDT20M-EMU3)	Emulator Adapter (supplied with ST7MDT20M-EMU3)
TQFP64 14 x14	CAB 3303262	CAB 3303351
TQFP64 10 x10	YAMAICHI IC149-064-*75-*5	YAMAICHI ICP-064-6
TQFP80 14 X 14	YAMAICHI IC149-080-*51-*5	YAMAICHI ICP-080-7

14.3.1 Socket and Emulator Adapter Information

For information on the type of socket that is supplied with the emulator, refer to the suggested list of sockets in [Table 32](#).

Note: Before designing the board layout, it is recommended to check the overall dimensions of the socket as they may be greater than the dimensions of the device.

For footprint and other mechanical information about these sockets and adapters, refer to the manufacturer's datasheet (www.yamaichi.de for

TQFP64 10 x 10 and TQFP80 14 x 14 and www.cabgmbh.com for TQFP64 14 x 14)

Related Documentation

AN 978: ST7 Visual Develop Software Key Debugging Features

AN 1938: ST7 Visual Develop for ST7 Cosmic C toolset users

AN 1939: ST7 Visual Develop for ST7 Metroworks C toolset users

AN 1940: ST7 Visual Develop for ST7 Assembler Linker toolset users

14.4 ST7 APPLICATION NOTES

Table 33. ST7 Application Notes

IDENTIFICATION	DESCRIPTION
APPLICATION EXAMPLES	
AN1658	SERIAL NUMBERING IMPLEMENTATION
AN1720	MANAGING THE READ-OUT PROTECTION IN FLASH MICROCONTROLLERS
AN1755	A HIGH RESOLUTION/PRECISION THERMOMETER USING ST7 AND NE555
AN1756	CHOOSING A DALI IMPLEMENTATION STRATEGY WITH ST7DALI
EXAMPLE DRIVERS	
AN 969	SCI COMMUNICATION BETWEEN ST7 AND PC
AN 970	SPI COMMUNICATION BETWEEN ST7 AND EEPROM
AN 971	I ² C COMMUNICATION BETWEEN ST7 AND M24CXX EEPROM
AN 972	ST7 SOFTWARE SPI MASTER COMMUNICATION
AN 973	SCI SOFTWARE COMMUNICATION WITH A PC USING ST72251 16-BIT TIMER
AN 974	REAL TIME CLOCK WITH ST7 TIMER OUTPUT COMPARE
AN 976	DRIVING A BUZZER THROUGH ST7 TIMER PWM FUNCTION
AN 979	DRIVING AN ANALOG KEYBOARD WITH THE ST7 ADC
AN 980	ST7 KEYPAD DECODING TECHNIQUES, IMPLEMENTING WAKE-UP ON KEYSTROKE
AN1017	USING THE ST7 UNIVERSAL SERIAL BUS MICROCONTROLLER
AN1041	USING ST7 PWM SIGNAL TO GENERATE ANALOG OUTPUT (SINUSOID)
AN1042	ST7 ROUTINE FOR I ² C SLAVE MODE MANAGEMENT
AN1044	MULTIPLE INTERRUPT SOURCES MANAGEMENT FOR ST7 MCUS
AN1045	ST7 S/W IMPLEMENTATION OF I ² C BUS MASTER
AN1046	UART EMULATION SOFTWARE
AN1047	MANAGING RECEPTION ERRORS WITH THE ST7 SCI PERIPHERALS
AN1048	ST7 SOFTWARE LCD DRIVER
AN1078	PWM DUTY CYCLE SWITCH IMPLEMENTING TRUE 0% & 100% DUTY CYCLE
AN1082	DESCRIPTION OF THE ST72141 MOTOR CONTROL PERIPHERALS REGISTERS
AN1083	ST72141 BLDC MOTOR CONTROL SOFTWARE AND FLOWCHART EXAMPLE
AN1105	ST7 PCAN PERIPHERAL DRIVER
AN1129	PWM MANAGEMENT FOR BLDC MOTOR DRIVES USING THE ST72141
AN1130	AN INTRODUCTION TO SENSORLESS BRUSHLESS DC MOTOR DRIVE APPLICATIONS WITH THE ST72141
AN1148	USING THE ST7263 FOR DESIGNING A USB MOUSE
AN1149	HANDLING SUSPEND MODE ON A USB MOUSE
AN1180	USING THE ST7263 KIT TO IMPLEMENT A USB GAME PAD
AN1276	BLDC MOTOR START ROUTINE FOR THE ST72141 MICROCONTROLLER
AN1321	USING THE ST72141 MOTOR CONTROL MCU IN SENSOR MODE
AN1325	USING THE ST7 USB LOW-SPEED FIRMWARE V4.X
AN1445	EMULATED 16 BIT SLAVE SPI
AN1475	DEVELOPING AN ST7265X MASS STORAGE APPLICATION
AN1504	STARTING A PWM SIGNAL DIRECTLY AT HIGH LEVEL USING THE ST7 16-BIT TIMER
AN1602	16-BIT TIMING OPERATIONS USING ST7262 OR ST7263B ST7 USB MCUS
AN1633	DEVICE FIRMWARE UPGRADE (DFU) IMPLEMENTATION IN ST7 NON-USB APPLICATIONS
AN1712	GENERATING A HIGH RESOLUTION SINEWAVE USING ST7 PWMART
AN1713	SMBUS SLAVE DRIVER FOR ST7 I ² C PERIPHERALS
AN1753	SOFTWARE UART USING 12-BIT ART
AN1947	ST7MC PMAC SINE WAVE MOTOR CONTROL SOFTWARE LIBRARY

Table 33. ST7 Application Notes

IDENTIFICATION	DESCRIPTION
GENERAL PURPOSE	
AN1476	LOW COST POWER SUPPLY FOR HOME APPLIANCES
AN1526	ST7FLITE0 QUICK REFERENCE NOTE
AN1709	EMC DESIGN FOR ST MICROCONTROLLERS
AN1752	ST72324 QUICK REFERENCE NOTE
PRODUCT EVALUATION	
AN 910	PERFORMANCE BENCHMARKING
AN 990	ST7 BENEFITS VERSUS INDUSTRY STANDARD
AN1077	OVERVIEW OF ENHANCED CAN CONTROLLERS FOR ST7 AND ST9 MCUS
AN1086	U435 CAN-DO SOLUTIONS FOR CAR MULTIPLEXING
AN1103	IMPROVED B-EMF DETECTION FOR LOW SPEED, LOW VOLTAGE WITH ST72141
AN1150	BENCHMARK ST72 VS PC16
AN1151	PERFORMANCE COMPARISON BETWEEN ST72254 & PC16F876
AN1278	LIN (LOCAL INTERCONNECT NETWORK) SOLUTIONS
PRODUCT MIGRATION	
AN1131	MIGRATING APPLICATIONS FROM ST72511/311/214/124 TO ST72521/321/324
AN1322	MIGRATING AN APPLICATION FROM ST7263 REV.B TO ST7263B
AN1365	GUIDELINES FOR MIGRATING ST72C254 APPLICATIONS TO ST72F264
AN1604	HOW TO USE ST7MDT1-TRAIN WITH ST72F264
PRODUCT OPTIMIZATION	
AN 982	USING ST7 WITH CERAMIC RESONATOR
AN1014	HOW TO MINIMIZE THE ST7 POWER CONSUMPTION
AN1015	SOFTWARE TECHNIQUES FOR IMPROVING MICROCONTROLLER EMC PERFORMANCE
AN1040	MONITORING THE VBUS SIGNAL FOR USB SELF-POWERED DEVICES
AN1070	ST7 CHECKSUM SELF-CHECKING CAPABILITY
AN1181	ELECTROSTATIC DISCHARGE SENSITIVE MEASUREMENT
AN1324	CALIBRATING THE RC OSCILLATOR OF THE ST7FLITE0 MCU USING THE MAINS
AN1502	EMULATED DATA EEPROM WITH ST7 HDFLASH MEMORY
AN1529	EXTENDING THE CURRENT & VOLTAGE CAPABILITY ON THE ST7265 VDDF SUPPLY
AN1530	ACCURATE TIMEBASE FOR LOW-COST ST7 APPLICATIONS WITH INTERNAL RC OSCILLATOR
AN1605	USING AN ACTIVE RC TO WAKEUP THE ST7LITE0 FROM POWER SAVING MODE
AN1636	UNDERSTANDING AND MINIMIZING ADC CONVERSION ERRORS
AN1828	PIR (PASSIVE INFRARED) DETECTOR USING THE ST7FLITE05/09/SUPERLITE
AN1946	SENSORLESS BLDC MOTOR CONTROL AND BEMF SAMPLING METHODS WITH ST7MC
AN1971	ST7LITE0 MICROCONTROLLED BALLAST
PROGRAMMING AND TOOLS	
AN 978	ST7 VISUAL DEVELOP SOFTWARE KEY DEBUGGING FEATURES
AN 983	KEY FEATURES OF THE COSMIC ST7 C-COMPILER PACKAGE
AN 985	EXECUTING CODE IN ST7 RAM
AN 986	USING THE INDIRECT ADDRESSING MODE WITH ST7
AN 987	ST7 SERIAL TEST CONTROLLER PROGRAMMING
AN 988	STARTING WITH ST7 ASSEMBLY TOOL CHAIN
AN 989	GETTING STARTED WITH THE ST7 HIWARE C TOOLCHAIN
AN1039	ST7 MATH UTILITY ROUTINES
AN1064	WRITING OPTIMIZED HIWARE C LANGUAGE FOR ST7
AN1071	HALF DUPLEX USB-TO-SERIAL BRIDGE USING THE ST72611 USB MICROCONTROLLER

Table 33. ST7 Application Notes

IDENTIFICATION	DESCRIPTION
AN1106	TRANSLATING ASSEMBLY CODE FROM HC05 TO ST7
AN1179	PROGRAMMING ST7 FLASH MICROCONTROLLERS IN REMOTE ISP MODE (IN-SITU PROGRAMMING)
AN1446	USING THE ST72521 EMULATOR TO DEBUG A ST72324 TARGET APPLICATION
AN1477	EMULATED DATA EEPROM WITH XFLASH MEMORY
AN1478	PORTING AN ST7 PANTA PROJECT TO CODEWARRIOR IDE
AN1527	DEVELOPING A USB SMARTCARD READER WITH ST7SCR
AN1575	ON-BOARD PROGRAMMING METHODS FOR XFLASH AND HDFLASH ST7 MCUS
AN1576	IN-APPLICATION PROGRAMMING (IAP) DRIVERS FOR ST7 HDFLASH OR XFLASH MCUS
AN1577	DEVICE FIRMWARE UPGRADE (DFU) IMPLEMENTATION FOR ST7 USB APPLICATIONS
AN1601	SOFTWARE IMPLEMENTATION FOR ST7DALI-EVAL
AN1603	USING THE ST7 USB DEVICE FIRMWARE UPGRADE DEVELOPMENT KIT (DFU-DK)
AN1635	ST7 CUSTOMER ROM CODE RELEASE INFORMATION
AN1754	DATA LOGGING PROGRAM FOR TESTING ST7 APPLICATIONS VIA ICC
AN1796	FIELD UPDATES FOR FLASH BASED ST7 APPLICATIONS USING A PC COMM PORT
AN1900	HARDWARE IMPLEMENTATION FOR ST7DALI-EVAL
AN1904	ST7MC THREE-PHASE AC INDUCTION MOTOR CONTROL SOFTWARE LIBRARY
AN1905	ST7MC THREE-PHASE BLDC MOTOR CONTROL SOFTWARE LIBRARY
SYSTEM OPTIMIZATION	
AN1711	SOFTWARE TECHNIQUES FOR COMPENSATING ST7 ADC ERRORS
AN1827	IMPLEMENTATION OF SIGMA-DELTA ADC WITH ST7FLITE05/09
AN2009	PWM MANAGEMENT FOR 3-PHASE BLDC MOTOR DRIVES USING THE ST7FMC
AN2030	BACK EMF DETECTION DURING PWM ON TIME BY ST7MC

15 KNOWN LIMITATIONS

15.1 ALL FLASH AND ROM DEVICES

15.1.1 External RC option

The External RC clock source option described in previous datasheet revisions is no longer supported and has been removed from this specification.

15.1.2 Safe Connection of OSC1/OSC2 Pins

The OSC1 and/or OSC2 pins must not be left unconnected otherwise the ST7 main oscillator may start and, in this configuration, could generate an f_{OSC} clock frequency in excess of the allowed maximum (>16MHz.), putting the ST7 in an unsafe/undefined state. Refer to [section 6.2 on page 25](#).

15.1.3 Reset pin protection with LVD Enabled

As mentioned in note 2 below [Figure 103 on page 186](#), when the LVD is enabled, it is recommended not to connect a pull-up resistor or capacitor. A 10nF pull-down capacitor is required to filter noise on the reset line.

15.1.4 Unexpected Reset Fetch

If an interrupt request occurs while a "POP CC" instruction is executed, the interrupt controller does not recognise the source of the interrupt and, by default, passes the RESET vector address to the CPU.

Workaround

To solve this issue, a "POP CC" instruction must always be preceded by a "SIM" instruction.

15.1.5 Clearing active interrupts outside interrupt routine

When an active interrupt request occurs at the same time as the related flag is being cleared, an unwanted reset may occur.

Note: clearing the related interrupt mask will not generate an unwanted reset

Concurrent interrupt context

The symptom does not occur when the interrupts are handled normally, i.e.

when:

- The interrupt flag is cleared within its own interrupt routine
- The interrupt flag is cleared within any interrupt routine
- The interrupt flag is cleared in any part of the code while this interrupt is disabled

If these conditions are not met, the symptom can be avoided by implementing the following sequence:

Perform SIM and RIM operation before and after resetting an active interrupt request.

Example:

```
SIM
reset interrupt flag
RIM
```

Nested interrupt context:

The symptom does not occur when the interrupts are handled normally, i.e.

when:

- The interrupt flag is cleared within its own interrupt routine
- The interrupt flag is cleared within any interrupt routine with higher or identical priority level
- The interrupt flag is cleared in any part of the code while this interrupt is disabled

If these conditions are not met, the symptom can be avoided by implementing the following sequence:

```
PUSH CC
SIM
reset interrupt flag
POP CC
```

KNOWN LIMITATIONS (Cont'd)

15.1.6 SCI Wrong Break duration

Description

A single break character is sent by setting and re-setting the SBK bit in the SCICR2 register. In some cases, the break character may have a longer duration than expected:

- 20 bits instead of 10 bits if M=0
- 22 bits instead of 11 bits if M=1.

In the same way, as long as the SBK bit is set, break characters are sent to the TDO pin. This may lead to generate one break more than expected.

Occurrence

The occurrence of the problem is random and proportional to the baudrate. With a transmit frequency of 19200 baud ($f_{CPU}=8MHz$ and $SCI-BRR=0xC9$), the wrong break duration occurrence is around 1%.

Workaround

If this wrong duration is not compliant with the communication protocol in the application, software can request that an Idle line be generated before the break character. In this case, the break duration is always correct assuming the application is not doing anything between the idle and the break. This can be ensured by temporarily disabling interrupts.

The exact sequence is:

- Disable interrupts
- Reset and Set TE (IDLE request)
- Set and Reset SBK (Break Request)
- Re-enable interrupts

15.1.7 16-bit Timer PWM Mode

In PWM mode, the first PWM pulse is missed after writing the value FFFCh in the OC1R register (OC1HR, OC1LR). It leads to either full or no PWM during a period, depending on the OLVL1 and OLVL2 settings.

15.1.8 CAN Cell Limitations

Limitation ¹	Flash	ROM
Omitted SOF bit	x	x
CPU write access (more than one cycle) corrupts CAN frame	x	x
Unexpected Message transmission	x ²	
Bus Off State Not Entered		x ⁴
WKPS Functionality		x ³

x=limitation present

¹For details see [section 10.8.5 on page 146](#)

²Software workaround possible using modified WKPS bit.

³Functionality modified for Unexpected Message Transmission workaround in Flash.

⁴Limitation present on ROM Rev W and Rev Z. Not present in Flash and ROM Rev Y.

15.1.9 I2C Multimaster

In multimaster configurations, if the ST7 I2C receives a START condition from another I2C master after the START bit is set in the I2CCR register and before the START condition is generated by the ST7 I2C, it may ignore the START condition from the other I2C master. In this case, the ST7 master will receive a NACK from the other device. On reception of the NACK, ST7 can send a re-start and Slave address to re-initiate communication

KNOWN LIMITATIONS (Cont'd)**15.2 ALL FLASH DEVICES****15.2.1 Internal RC Oscillator with LVD**

The internal RC can only be used if LVD is enabled.

15.2.2 I/O behaviour during ICC mode entry sequence**Symptom**

In 80-pin devices (Flash), both Port G and H are forced to output push-pull during ICC mode entry sequence. 80-pin ROM devices are not impacted by this issue.

Details

To enable programming of all flash sectors, the device must leave USER mode and be configured in ICC mode. Once in ICC mode, the ICC protocol enables an ST7 microcontroller to communicate with an external controller (such as a PC). ICC mode is entered by applying 39 pulses on the IC-CDATA signal during reset. To enter ICC mode, the device goes through other modes, some

modes are critical because the I/Os PG[7:0] and PH[7:0] are forced to output push-pull.

Impact on the Application

The PG and PH I/O ports are forced to output push-pull during three pulses on IC-CDATA. In certain circumstances, this behaviour can lead to a short-circuit between the I/O signals and V_{DD} , V_{SS} or an output signal of another application component.

In addition, switching these I/Os to output mode can cause the application to leave reset state, disturbing the ICC communication and preventing the user from programming the flash.

15.2.3 Read-out protection with LVD

The LVD is not supported if Readout protection is enabled.

16 REVISION HISTORY

Table 34. Revision History

Date	Revision	Description of Changes
7-Dec-2004	3	Added Figure 82 on page 153 Reinstated "I/O behaviour during ICC mode entry sequence" on page 213 Reinstated "BUSOFF not entered" in "CAN Cell Limitations" on page 212 Added "flash only" to PC6 linj spec in Section 12.2 and Section 12.8
4-Mar-2005	4	Added Note on SMbus to Section 10.7 Static current consumption modified in section 12.8 on page 182 Updated footnote and Figure 103 and Figure 104 on page 186 Modified VtPOR in section 12.3.2 on page 168 Added note 4 below Table of "CAN Cell Limitations" on page 212
18-May-2005	5	Corrected MCO description in Table 1 and Section 10.2 Updated footnotes and Figure 103 and Figure 104 on page 186 . Updated soldering information in section 13.3 on page 200 Added Suffix 3 to Figure 118 on page 203 Updated partnumbers in Table 30 on page 205 Added "Reset pin protection with LVD Enabled" on page 211

Notes:

Information furnished is believed to be accurate and reliable. However, STMicroelectronics assumes no responsibility for the consequences of use of such information nor for any infringement of patents or other rights of third parties which may result from its use. No license is granted by implication or otherwise under any patent or patent rights of STMicroelectronics. Specifications mentioned in this publication are subject to change without notice. This publication supersedes and replaces all information previously supplied. STMicroelectronics products are not authorized for use as critical components in life support devices or systems without express written approval of STMicroelectronics.

The ST logo is a registered trademark of STMicroelectronics.

All other names are the property of their respective owners

© 2005 STMicroelectronics - All rights reserved

STMicroelectronics group of companies

Australia – Belgium - Brazil - Canada - China – Czech Republic - Finland - France - Germany - Hong Kong - India - Israel - Italy - Japan - Malaysia - Malta - Morocco - Singapore - Spain - Sweden - Switzerland - United Kingdom - United States of America

www.st.com



Looking for pricing, stock, or lifecycle information?

Click below to explore more details on WIN SOURCE:

 [View ST72F521R9T6 on WIN SOURCE](#)

 [STMicroelectronics](#) Information

Optimize Your Supply Chain with WIN SOURCE Solutions

-  Global Sourcing Solution
-  Obsolete Management
-  Cost Control Management
-  Shortage Management
-  Alternative Solution
-  Excess Inventory Management