

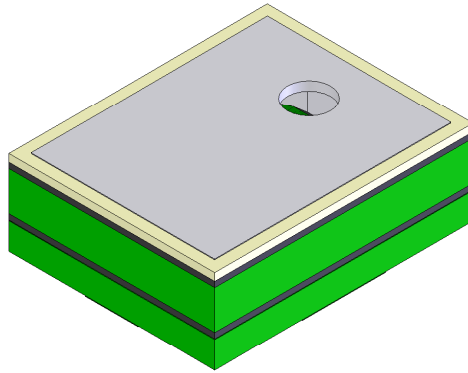

THE DATASHEET OF SPM0408HE5H-SB



Amplified “Mini” SiSonic™ Microphone Specification With Enhanced RF Protection – *Halogen Free*



Knowles Acoustics
1151 Maplewood Drive
Itasca, IL 60143

1. DESCRIPTION AND APPLICATION

1.1 Description

Amplified “Mini” Surface Mount Silicon Microphone with Enhanced RF Protection – *Halogen Free*

1.2 Application

Hand held consumer electronics

2. PART MARKING

Identification Number Convention

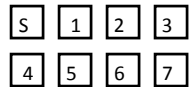

S: Manufacturing Location

“S” – Knowles Electronics Suzhou
Suzhou, China

“No Alpha Character” – Knowles Electronics Itasca
Itasca, IL USA

“E” – Engineering Samples

Digits 1 – 7: Job Identification Number

3. TEMPERATURE RANGE

3.1 Operating Temperature Range: -40°C to +100°C

3.2 Storage Temperature Range: -40°C to +100°C

4. ACOUSTIC & ELECTRICAL SPECIFICATIONS

	Symbol	Condition	Limits			Unit
			Min.	Nom.	Max.	
Directivity		Omni-directional				
Sensitivity	S	@ 1kHz (0dB=1V/Pa)	-25	-22	-19	dB
Output impedance	Z _{OUT}	@ 1kHz (0dB=1V/Pa)	---	---	300	Ω
Current Consumption	I _{DSS}	across 1.5 to 3.6 volts	---	---	350	μA
Signal to Noise Ratio	S/N	@ 1kHz (0dB=1V/Pa)	---	59	---	dB
Supply Voltage	Vs		1.5	---	3.6	V
Sensitivity Loss across Voltage		Change in sensitivity over 3.6v to 1.5v	No Change Across Voltage Range			dB
THD		At 100dB SPL, THD < 1% At 115dB SPL, THD = < 10%				dB

5. FREQUENCY RESPONSE CURVE

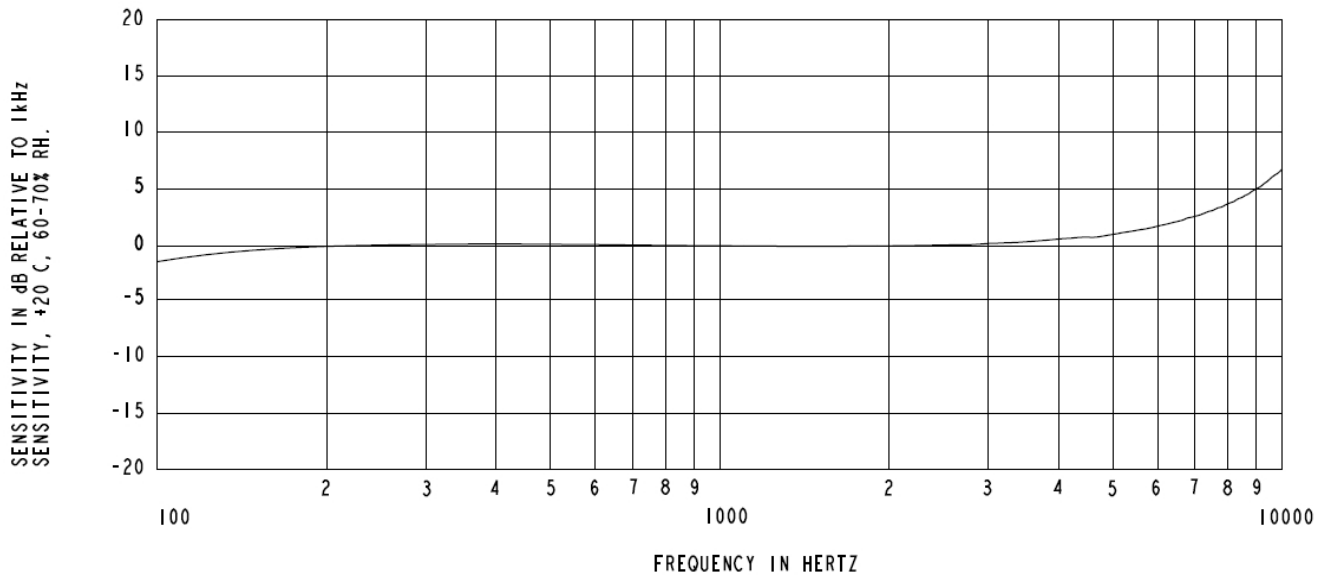

6. MECHANICAL SPECIFICATIONS

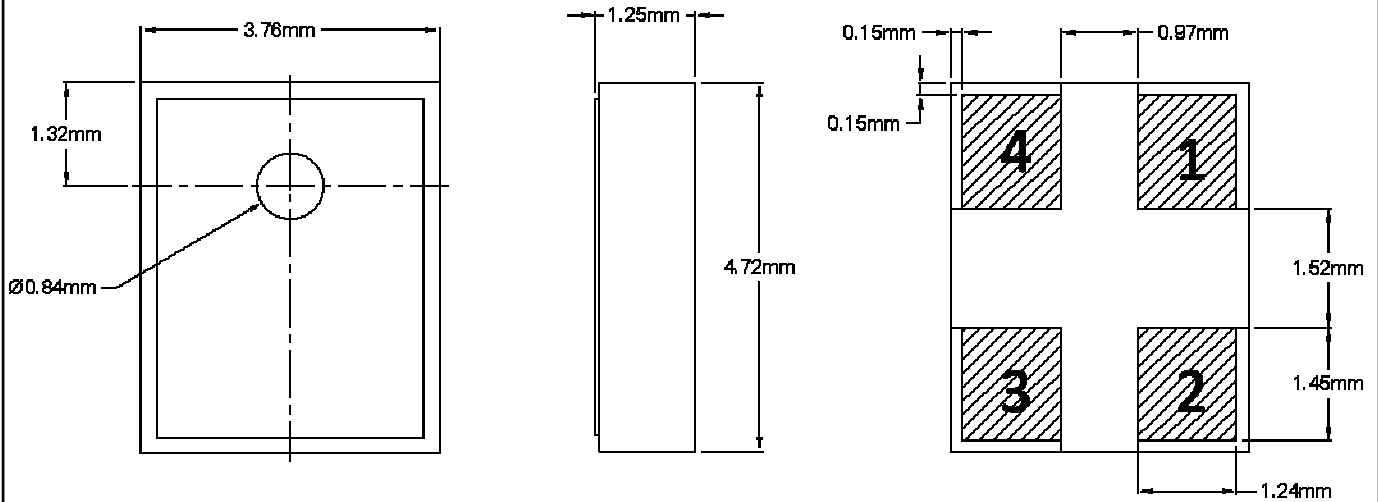

Pin Output	
Pin #	Function
1	Output
2	Gain Control
3	Ground
4	Power

Item	Dim.	Tol. (+/-)	Units
Height	1.25	0.10	mm
Length	4.72	0.10	mm
Width	3.76	0.10	mm
Port Hole	0.84	0.15	mm
Short Edge to C.L. Port	1.32	0.25	mm
Long Edge to C.L. Port	1.88	0.25	mm

Note: (Tolerance +/-0.15mm unless otherwise specified)

7. RECOMMENDED CUSTOMER LAND PATTERN

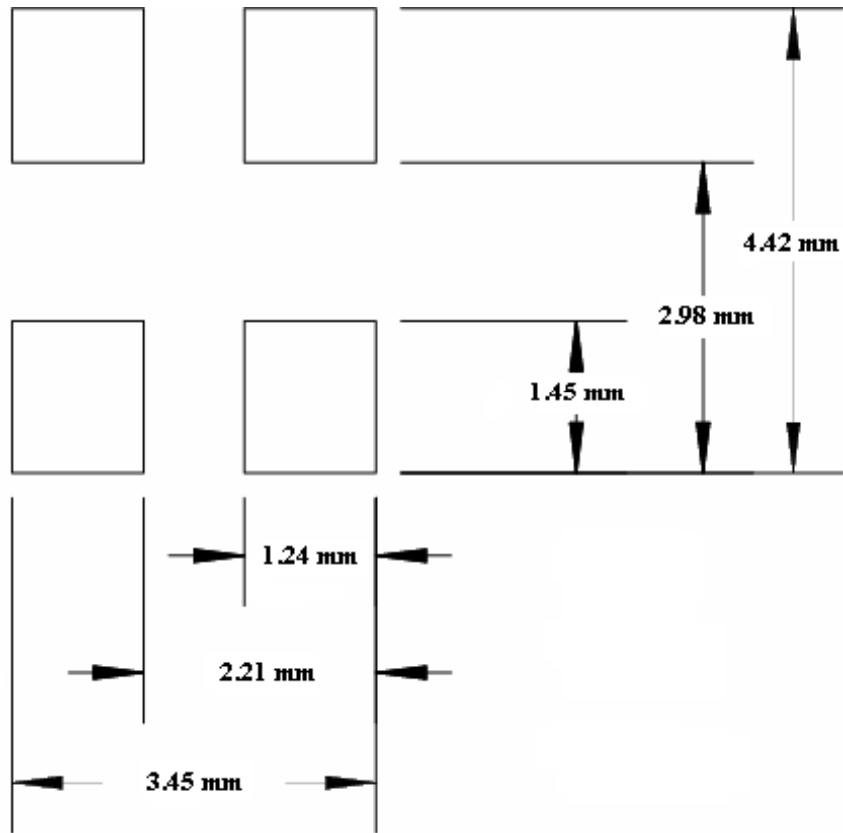

8. RECOMMENDED SOLDER STENCIL PATTERN

N/A

9. RECOMMENDED INTERFACE CIRCUIT

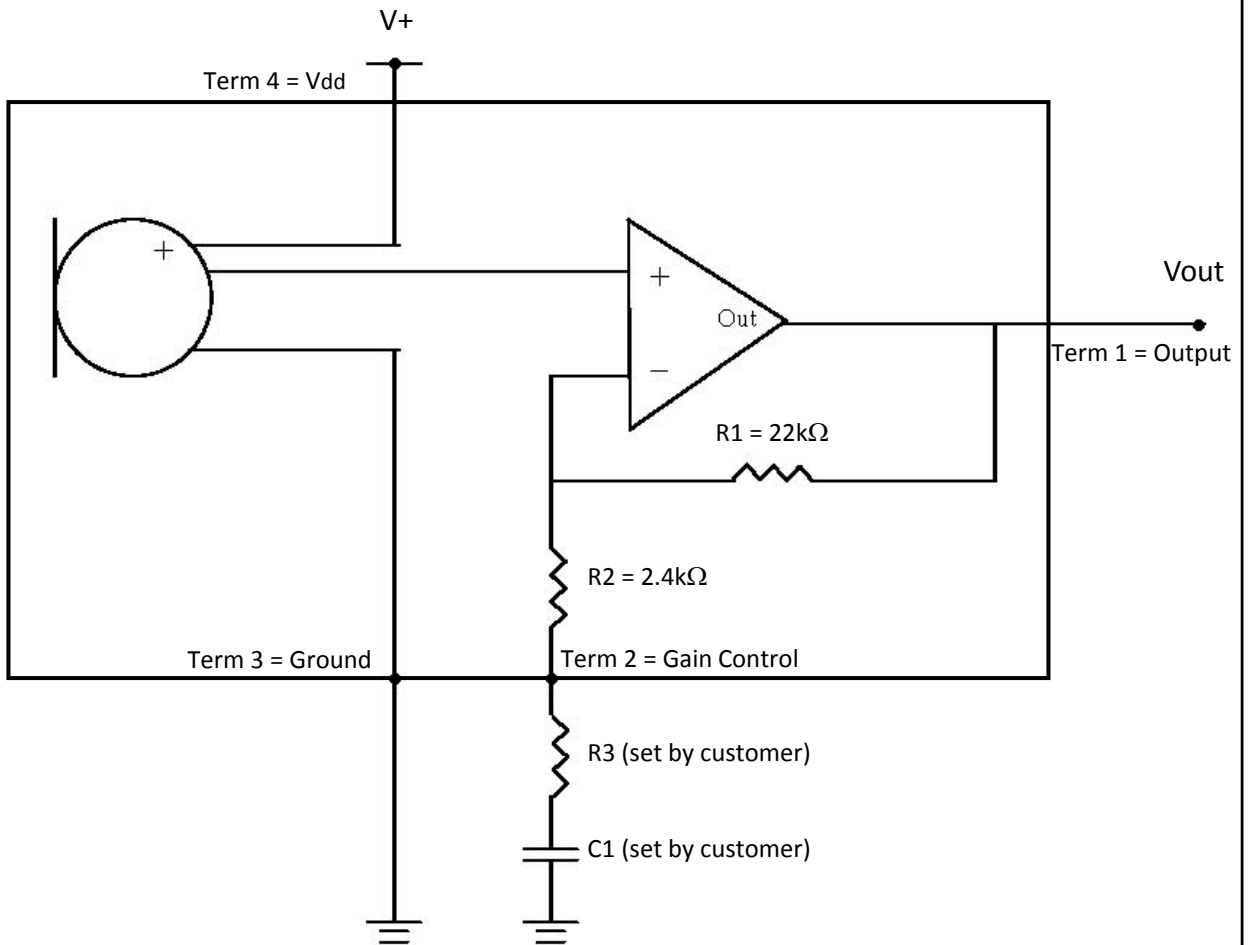

Desired Gain	Pin 2 Termination Method
Unity Gain (0dB)	Tie Terminal 2 directly to Output (Terminal 1).
20dB Gain	Tie Terminal 2 through C1 (0.47uF) to Ground.
Adjustable Gain	Add R3 and C1. Use formulas provided to calculate settings, or contact Knowles for support.

Setting Gain Formulas:

Gain of non-inverting Op-Amp is determined as:

$$\rightarrow G = 1 + \left\{ \frac{R1}{R2 + R3} \right\}$$

$$\text{Gain(dB)} = 20 * \log(G)$$

High-pass-filter Corner Frequency:

$$\rightarrow \text{C.F.} = 1 / \{ 2 * \pi * (R2 + R3) * C1 \}$$

11. SOLDER REFLOW PROFILE

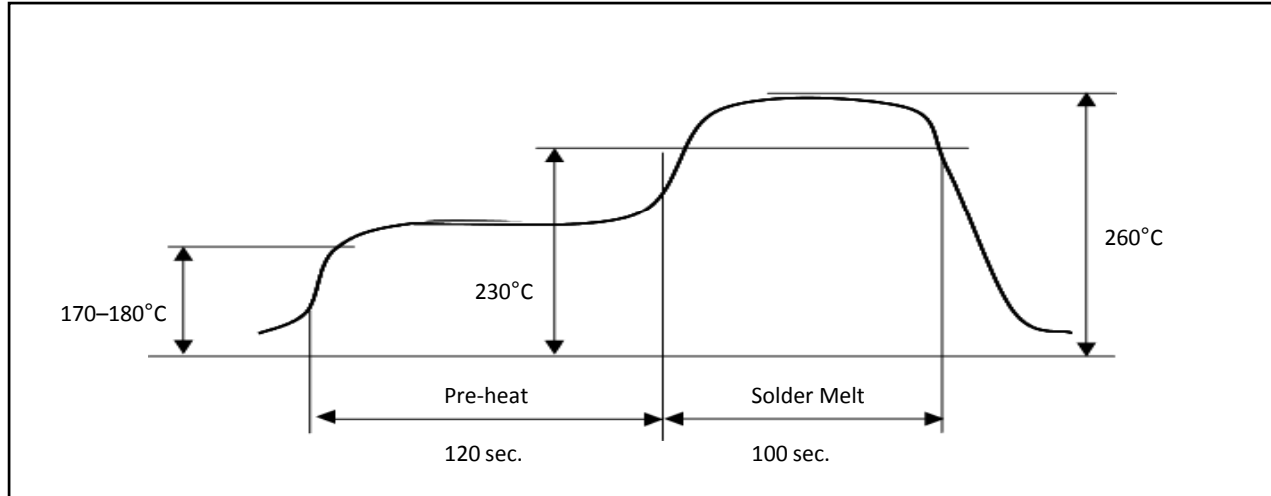

<u>Stage</u>	<u>Temperature Profile</u>	<u>Time (maximum)</u>
Pre-heat	170 ~ 180 C	120 sec.
Solder Melt	Above 230 C	100 sec.
Peak	260 C maximum	30 sec.

Notes:

1. Do not pull a vacuum over the port hole of the microphone. Pulling a vacuum over the port hole can damage the device.
2. Do not board wash after the reflow process. Board washing and cleaning agents can damage the device. Do not expose to ultrasonic processing or cleaning.
3. Number of Reflow = recommend no more than 3 cycles.

12. ADDITIONAL NOTES

- (A) Shelf life: Twelve (12) months when devices are to be stored in factory supplied, unopened ESD moisture sensitive bag under maximum environmental conditions of 30°C, 70% R.H.
- (B) MSL (moisture sensitivity level) Class 2a.

13. RELIABILITY SPECIFICATIONS

Note: After test conditions are performed, the sensitivity of the microphone shall not deviate more than 3dB from its initial value.

Test	Description
Thermal Shock	100 cycles of air-air thermal shock from -40C to +125C with 15min soaks. (ICE 68-2-4)
High Temperature Storage	+105C environment for 1,000 hours. (IEC 68-2-2 Test Ba)
Low Temperature Storage	-40C environment for 1,000 hours. (IEC 68-2-2 Test Aa)
High Temperature Bias	+105C environment while under bias for 1,000 hours. (IEC 68-2-2 Test Ba)
Low Temperature Bias	-40C environment while under bias for 1,000 hours. (IEC 68-2-2 Test Aa)
Temperature / Humidity Bias	+85C/85% RH environment while under bias for 500 hours. (JESD22-A101A-B)
Vibration	4 cycles lasting 12 minutes from 20 to 2,000Hz in X, Y, and Z direction with a peak acceleration of 20g. (MIL 883E, Method 2007.2, A)
Electrostatic Discharge	3 discharges at +/- 8kV direct contact to the lid when unit is grounded (IEC 61000-4-2) and 3 discharges at +/- 2kV direct contact to the I/O pins (MIL 883E, Method 3015.7)
Reflow	5 reflow cycles with peak temperature of 260C.
Mechanical Shock	3 pulses of 10,000g in the X, Y, and Z direction. (IEC 68-2-27, Test Ea)

Looking for pricing, stock, or lifecycle information?

Click below to explore more details on WIN SOURCE:

 [View SPM0408HE5H-SB on WIN SOURCE](#)

 [Knowles](#) Information

Optimize Your Supply Chain with WIN SOURCE Solutions

-  Global Sourcing Solution
-  Obsolete Management
-  Cost Control Management
-  Shortage Management
-  Alternative Solution
-  Excess Inventory Management