



**THE DATASHEET OF  
SPA-2118Z**





RoHS Compliant and Pb-Free Product (Z Part Number)  
Package: ESOP-8

### Product Description

RFMD's SPA-2118 is a high efficiency GaAs Heterojunction Bipolar Transistor (HBT) amplifier housed in a low-cost surface-mountable plastic package. These HBT amplifiers are fabricated using molecular beam epitaxial growth technology which produces reliable and consistent performance from wafer to wafer and lot to lot. This product is specifically designed for use as a driver amplifier for infrastructure equipment in the 850MHz band. Its high linearity makes it an ideal choice for multi-carrier and digital applications.

#### Optimum Technology Matching® Applied

- GaAs HBT
- GaAs MESFET
- InGaP HBT
- SiGe BiCMOS
- Si BiCMOS
- SiGe HBT
- GaAs pHEMT
- Si CMOS
- Si BJT
- GaN HEMT
- RF MEMS

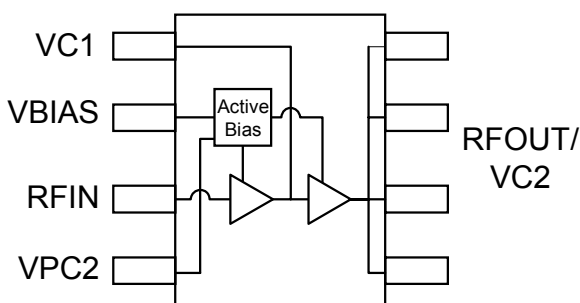

### Features

- High Linearity Performance
- +20.7 dBm, IS-95 CDMA Channel Power at -55 dBc ACP
- +47 dBm Typ. OIP3
- High Gain: 33dB Typ.
- On-Chip Active Bias Control
- Patented high Reliability GaAs HBT Technology
- Surface-Mountable Plastic Package

### Applications

- IS-95 CDMA Systems
- Multi-Carrier Applications
- AMPS, ISM Applications

Parameter	Specification			Unit	Condition
	Min.	Typ.	Max.		
Frequency of Operation	810	900	960	MHz	
Output Power at 1dB Compression		29.0		dBm	
Adjacent Channel Power		-55.0	-52.0	dBc	IS-95 at 880MHz, ±885KHz offset, P <sub>OUT</sub> =20.7 dBm
Small Signal Gain	31.5	33.0	34.5	dB	880MHz
Input VSWR		1.5:1			
Output Third Order Intercept Point		47.0		dBm	Power out per tone = +14 dBm
Noise Figure		5.0		dB	
Device Current	360	400	425	mA	I <sub>BIAS</sub> =10mA, I <sub>C1</sub> =70mA, I <sub>C2</sub> =320mA
Device Voltage	4.75	5.0	5.25	V	
Thermal Resistance (Junction - Lead)		31		°C/W	T <sub>L</sub> =85°C

Test Conditions: Z<sub>0</sub>=50Ω Temp=25°C V<sub>CC</sub>=5.0V

## Absolute Maximum Ratings

Parameter	Rating	Unit
Max Supply Current ( $I_{C1}$ ) at $V_{CC}$ typ.	150	mA
Max Supply Current ( $I_{C2}$ ) at $V_{CC}$ typ.	750	mA
Max Device Voltage ( $V_{CC}$ ) at $I_{CC}$ typ.	6.0	V
Max RF Input Power	10	dBm
Max Junction Temp ( $T_J$ )	+160	°C
Max Storage Temp	+150	°C
MSL	1	



**Caution!** ESD sensitive device.

Exceeding any one or a combination of the Absolute Maximum Rating conditions may cause permanent damage to the device. Extended application of Absolute Maximum Rating conditions to the device may reduce device reliability. Specified typical performance or functional operation of the device under Absolute Maximum Rating conditions is not implied.

RoHS status based on EU Directive 2002/95/EC (at time of this document revision).

The information in this publication is believed to be accurate and reliable. However, no responsibility is assumed by RF Micro Devices, Inc. ("RFMD") for its use, nor for any infringement of patents, or other rights of third parties, resulting from its use. No license is granted by implication or otherwise under any patent or patent rights of RFMD. RFMD reserves the right to change component circuitry, recommended application circuitry and specifications at any time without prior notice.

Operation of this device beyond any one of these limits may cause permanent damage. For reliable continuous operation, the device voltage and current must not exceed the maximum operating values specified in the table on page one.

Bias Conditions should also satisfy the following expression:

$$I_D V_D < (T_J - T_{JL}) / R_{TH, j-l}$$

## 850MHz to 950MHz Application Circuit Data, $I_{CC}=400\text{mA}$ , $V_{CC}=5\text{V}$ , IS-95, 9 Channels Forward

**880 MHz Adjacent Channel Power vs. Channel Output Power**

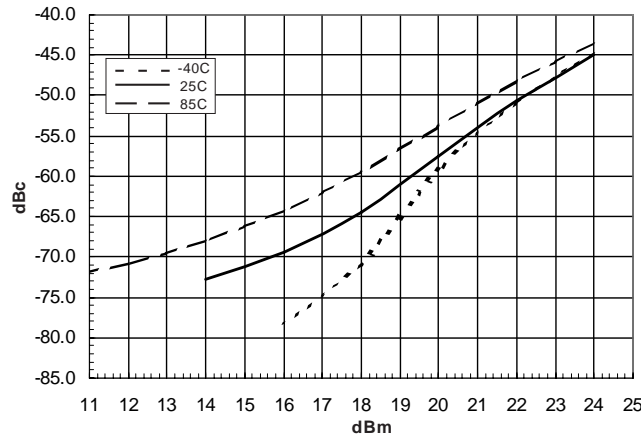

**IS-95 CDMA at 880 MHz**

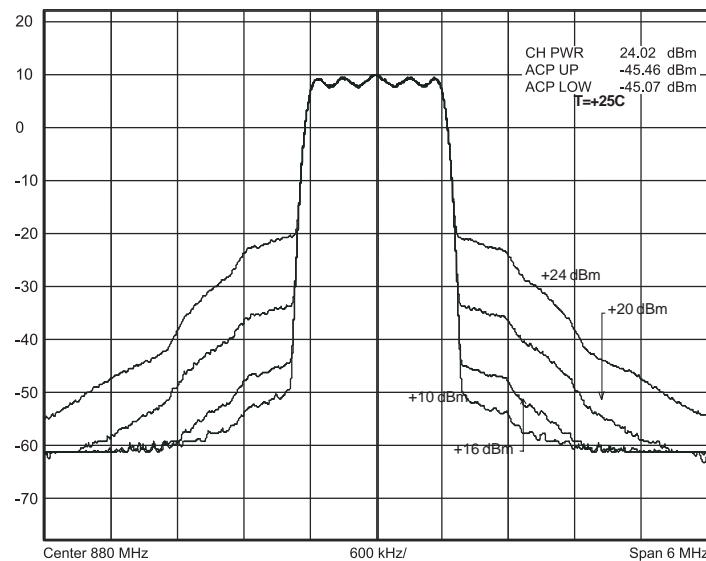

850MHz to 950MHz Application Circuit Data,  $I_{CC}=400\text{mA}$ ,  $V_{CC}=5\text{V}$

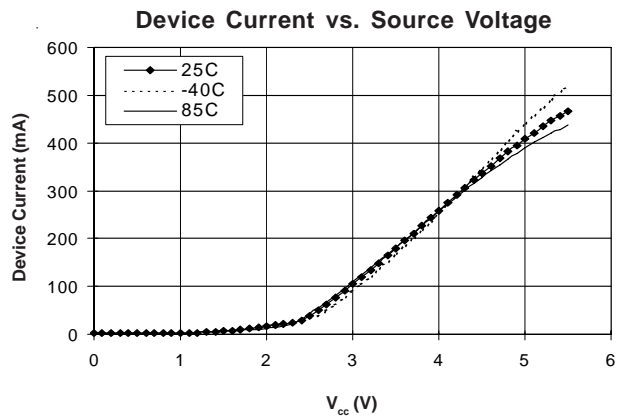
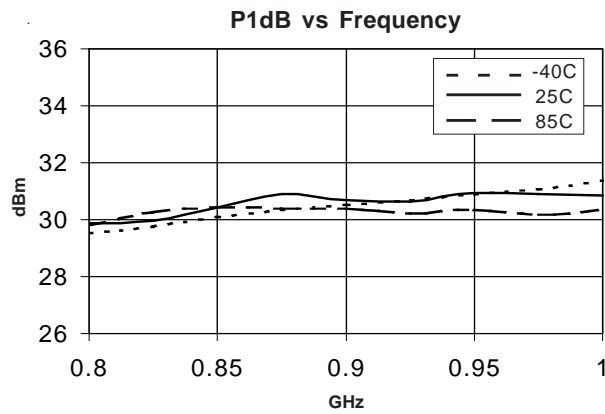
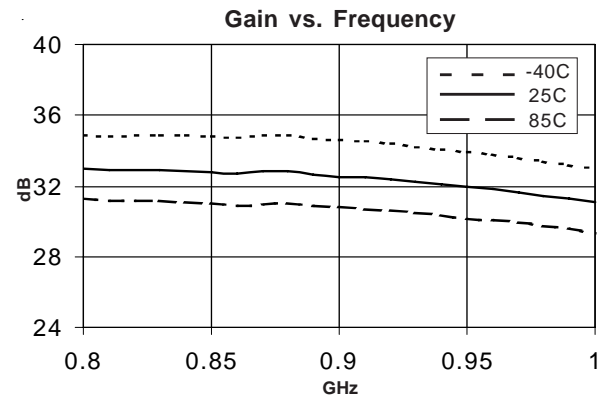
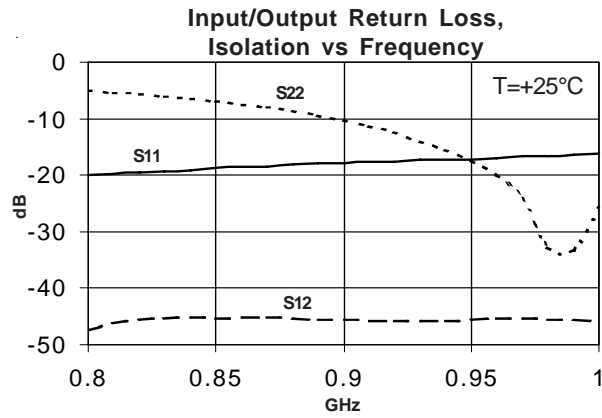

Pin	Function	Description
1	VC1	Supply voltage for the first stage transistor. The configuration as shown on the application schematic is required for optimum RF performance.
2	VBIAS	Bias control pin for the active bias network. Recommended configuration is shown in the application schematic.
3	RF IN	RF input pin. This pin requires the use of an external DC-blocking capacitor as shown in the application schematic.
4	VPC2	Bias control pin for the active bias network for the second stage. The recommended configuration is shown in the application schematic.
5, 6, 7, 8	RF OUT/VC2	RF output and bias pin. Bias should be supplied to this pin through an external RF choke. Because DC biasing is present on this pin a DC-blocking capacitor should be used in most applications. (See application schematic.) The supply side of the bias network should be well bypassed. An output matching network is necessary for optimum performance.
EPAD	GND	Exposed area on the bottom side of the package needs to be soldered to the ground plane of the board for thermal and RF performance. Several vias should be located under the EPAD as shown in the recommended land pattern.

## Simplified Device Schematic

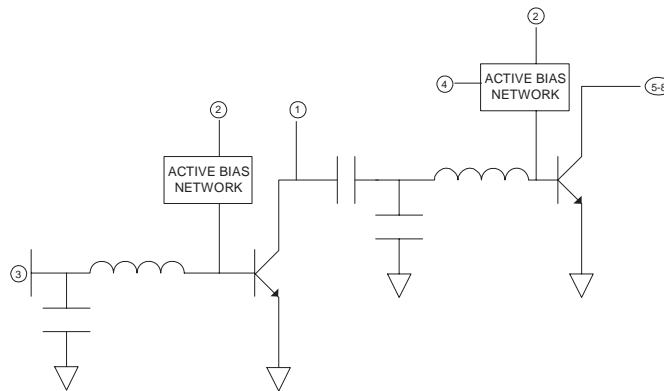

## Recommended Land Pattern

Dimensions in inches (millimeters)

Refer to drawing posted at [www.rfmd.com](http://www.rfmd.com) for tolerances.

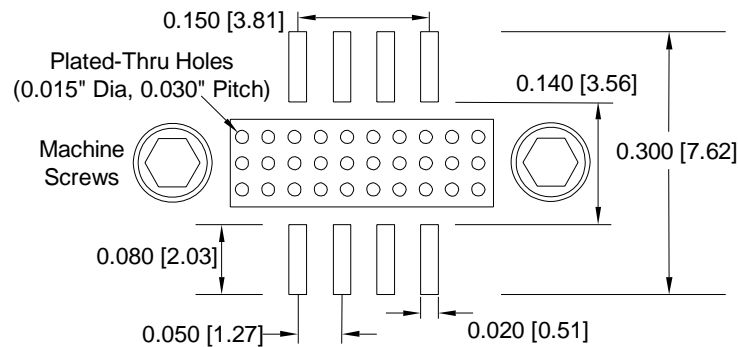

**Package Drawing**

Dimensions in inches (millimeters)

Refer to drawing posted at [www.rfmd.com](http://www.rfmd.com) for tolerances.

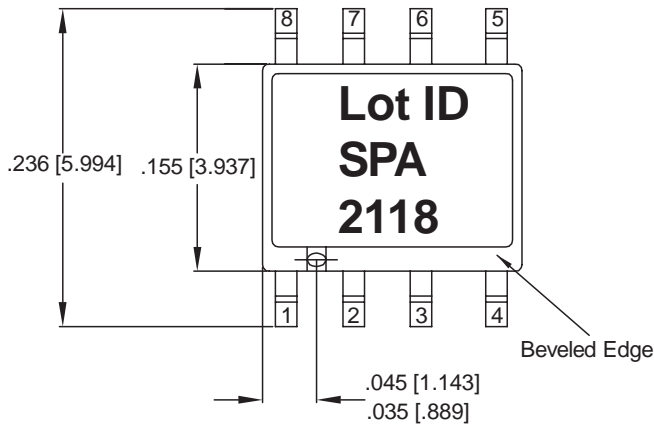

TOP VIEW

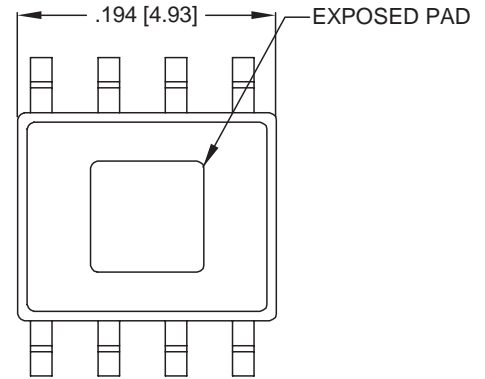

BOTTOM VIEW

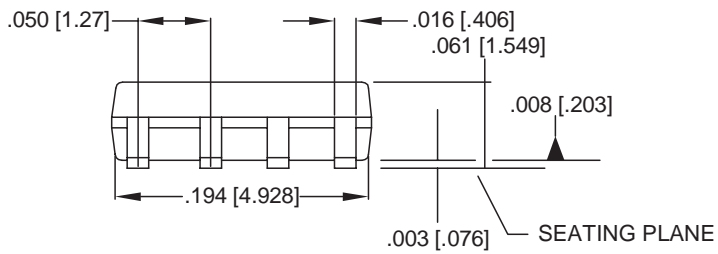

SIDE VIEW

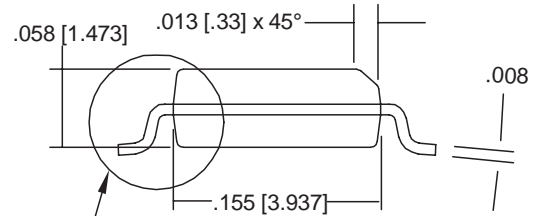

END VIEW

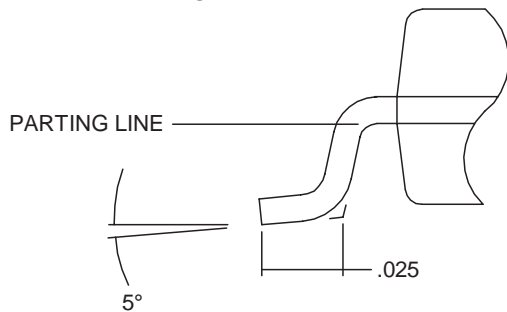

DETAIL A

## 850 MHz to 950 MHz Application Schematic

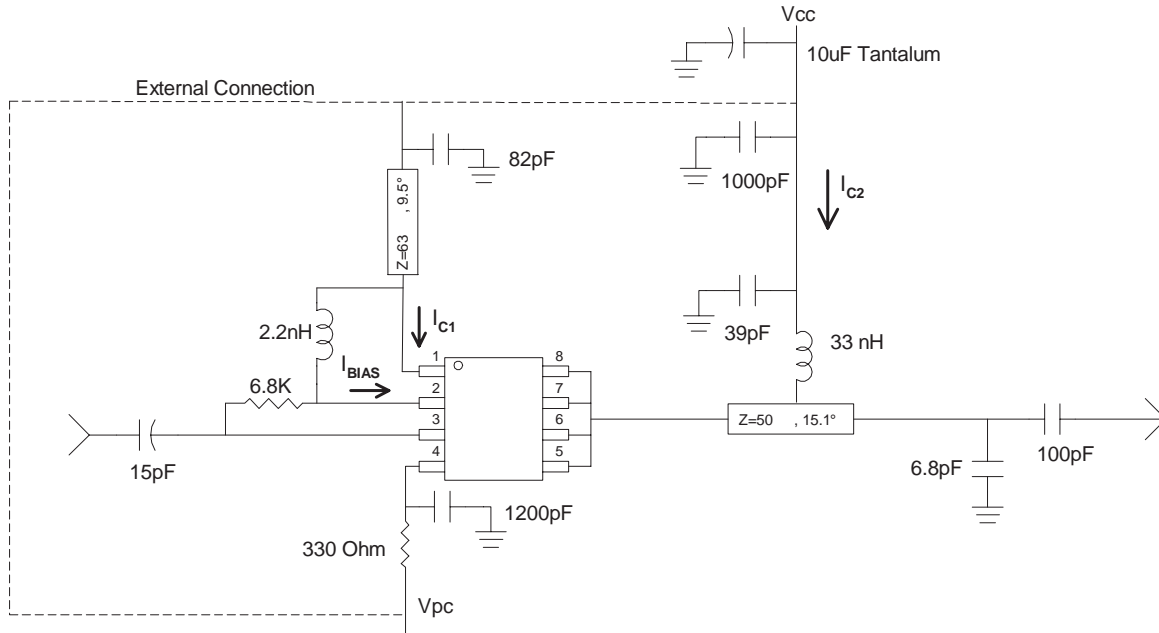

## 850 MHz to 950 MHz Evaluation Board Layout and Bill of Materials

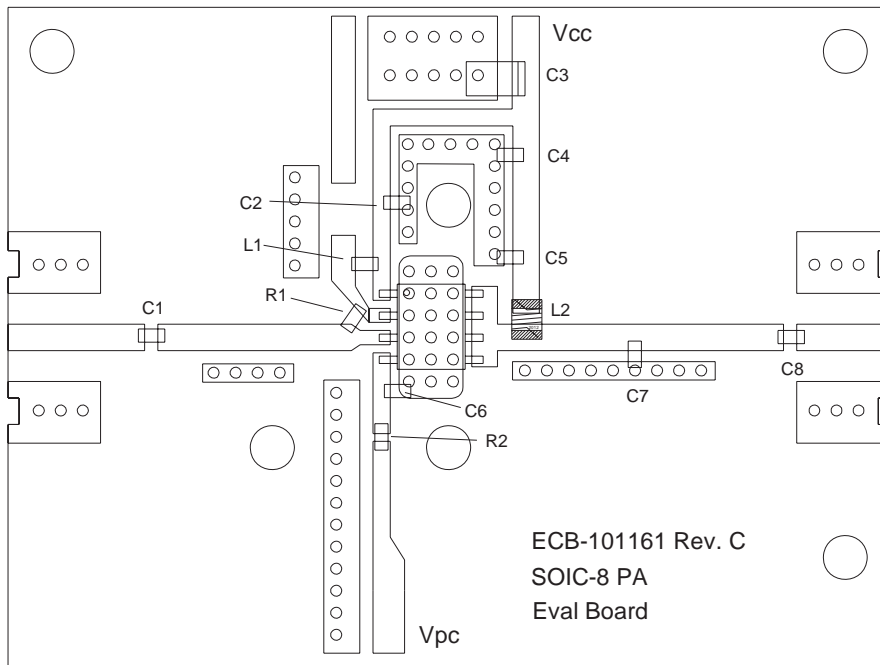

Ref. Des.	Value	Part Number
C1	15pF, 5%	Rohm MCH18 series
C2	82pF, 5%	Rohm MCH18 series
C3	10uF, 10%	AVX TAJB106K020R
C4	1000pF, 5%	Rohm MCH18 series
C5	39pF, 5%	Rohm MCH18 series
C6	1200pF, 5%	Rohm MCH18 series
C7	6.8pF, ±0.5pF	Rohm MCH18 series
C8	100pF, 5%	Rohm MCH18 series
L1	2.2nH, ±0.3nH	Toko LL1608-FS series
L2	33nH, 5%	Coilcraft 1008HQ series
R1	6.8K Ohm, 5%	Rohm MCR03 series
R2	330 Ohm, 5%	Rohm MCR03 series

## Part Identification

The part will be symbolized with an “SPA-2118” for Sn/Pb plating or “SPA-2118Z” for RoHS Compliant Product.



## Ordering Information

Part Number	Reel Size	Devices/Reel
SPA-2118	7"	500
SPA-2118Z	7"	500



## Looking for pricing, stock, or lifecycle information?

Click below to explore more details on WIN SOURCE:

-  [View SPA-2118Z on WIN SOURCE](#)
-  [RF Micro Devices Information](#)

## Optimize Your Supply Chain with WIN SOURCE Solutions

-  Global Sourcing Solution
-  Obsolete Management
-  Cost Control Management
-  Shortage Management
-  Alternative Solution
-  Excess Inventory Management