



**THE DATASHEET OF  
SN75DP118RHHT**



## DisplayPort 1:1 Buffer

### FEATURES

- Supports Data Rates up to 2.7 Gbps
- Supports Dual-Mode DisplayPort
- Output Waveform Mimics Input Waveform Characteristics
- Enhanced ESD: 12 KV on all pins
- Enhanced Commercial Temperature Range: 0°C to 85°C
- 36 Pin 6 × 6 QFN Package

### APPLICATIONS

- Personal Computer Market
  - Desktop PC
  - Notebook PC
  - Docking Station
  - Standalone Video Card

### DESCRIPTION

The SN75DP118 is a one Dual-Mode DisplayPort input to one Dual-Mode DisplayPort output. The output follows the input signal in a manner that provides the highest level of signal integrity while supporting the EMI benefits of spread spectrum clocking. The SN75DP118 data rates of up to 2.7 Gbps through each link for a total throughput of up to 10.8 Gbps can be realized.

In addition to the DisplayPort high speed signal lines, the SN75DP118 also supports the Hot Plug Detect (HPD) and Cable Adapter Detect (CAD) channels.

The SN75DP118 is characterized for operation over ambient air temperature of 0°C to 85°C.

### TYPICAL APPLICATION

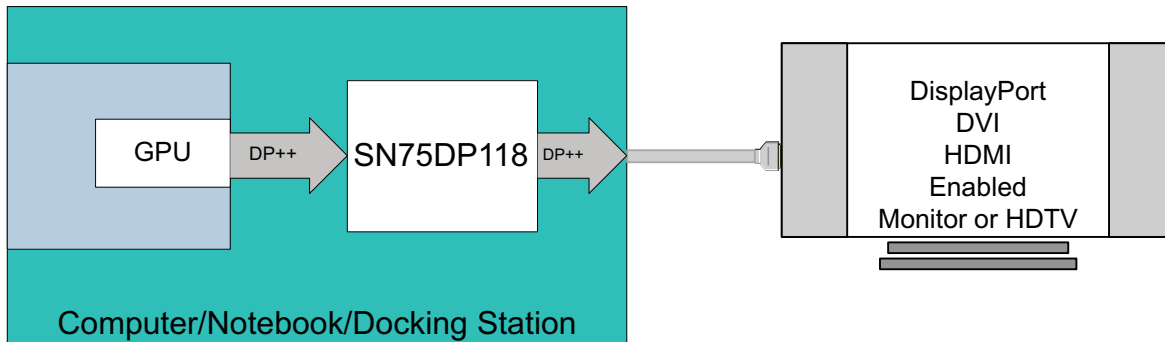

Please be aware that an important notice concerning availability, standard warranty, and use in critical applications of Texas Instruments semiconductor products and disclaimers thereto appears at the end of this data sheet.



These devices have limited built-in ESD protection. The leads should be shorted together or the device placed in conductive foam during storage or handling to prevent electrostatic damage to the MOS gates.

**DATA FLOW BLOCK DIAGRAM**

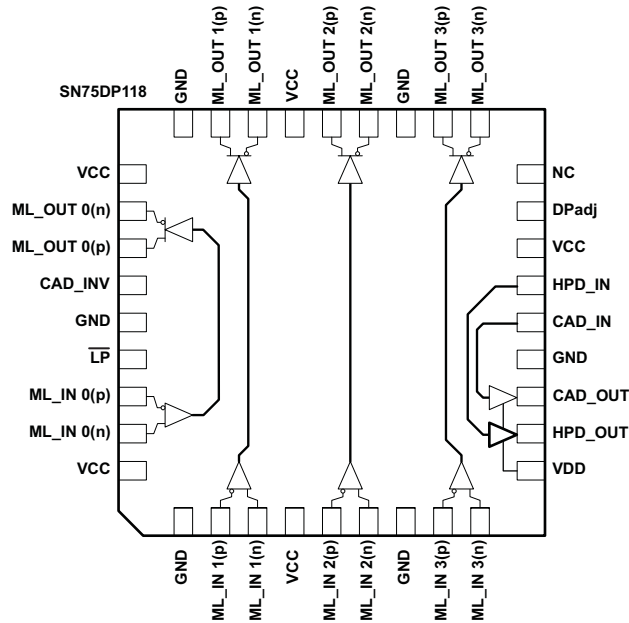

**PACKAGE**

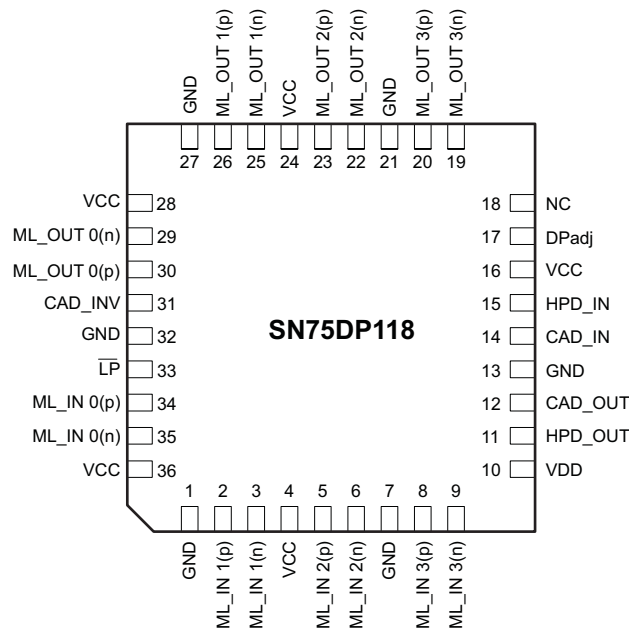

### PIN FUNCTIONS

PIN		I/O	DESCRIPTION
SIGNAL	NO.		
<b>MAIN LINK INPUT PINS</b>			
ML_IN 0	34, 35	I	DisplayPort Main Link Channel 0 Differential Input
ML_IN 1	2, 3	I	DisplayPort Main Link Channel 1 Differential Input
ML_IN 2	5, 6	I	DisplayPort Main Link Channel 2 Differential Input
ML_IN 3	8, 9	I	DisplayPort Main Link Channel 3 Differential Input
<b>MAIN LINK OUTPUT PINS</b>			
ML_OUT 0	30, 29	O	DisplayPort Main Link Port A Channel 0 Differential Output
ML_OUT 1	26, 25	O	DisplayPort Main Link Port A Channel 1 Differential Output
ML_OUT 2	23, 22	O	DisplayPort Main Link Port A Channel 2 Differential Output
ML_OUT 3	20, 19	O	DisplayPort Main Link Port A Channel 3 Differential Output
<b>HOT PLUG DETECT PINS</b>			
HPD_OUT	11	O	Hot Plug Detect Output to the DisplayPort Source
HPD_IN	15	I	Hot Plug Detect Input from the DisplayPort Connector
<b>CABLE ADAPTER DETECT PINS</b>			
CAD_OUT	12	O	Cable Adapter Detect Output to the DisplayPort Source
CAD_IN	14	I	Cable Adapter Detect Input from the DisplayPort Connector
<b>CONTROL PINS</b>			
$\overline{\text{LP}}$	33	I	Low Power Select Bar
CAD_INV	31	I	Output Port Priority selection
DP <sub>adj</sub>	17	I	DisplayPort Main Link Output Gain Adjustment
NC	16		Not Connected
<b>SUPPLY AND GROUND PINS</b>			
VCC	4, 16, 24, 28, 36		Primary Supply Voltage
VDD	10		HPD and CAD Output Voltage
GND	1, 7, 13, 21, 27, 32		Ground

**Table 1. Control Pin Lookup**

SIGNAL	LEVEL <sup>(1)</sup>	STATE	DESCRIPTION
$\overline{\text{LP}}$	H	Normal Mode	Normal operational mode for device
	L	Low Power Mode	Device is forced into a Low Power state causing the outputs to go to a high impedance state. All other inputs are ignored.
CAD_INV	H	CAD Inverted	The CAD output logic is inverted from the CAD input
	L	CAD not Inverted	The CAD output logic follows the CAD input
DP <sub>adj</sub>	4.53 k $\Omega$	Increased Gain	Main Link DisplayPort Output will have an increased voltage swing
	6.49 k $\Omega$	Nominal Gain	Main Link DisplayPort Output will have a nominal voltage swing
	10 k $\Omega$	Decreased Gain	Main Link DisplayPort Output will have a decreased voltage swing

(1) (H) Logic High; (L) Logic Low

### ORDERING INFORMATION

PART NUMBER	PART MARKING	PACKAGE <sup>(1)</sup>
SN75DP118RHHR	DP118	36-pin QFN Reel (large)
SN75DP118RHHT	DP118	36-pin QFN Reel (small)

(1) For the most current package and ordering information, see the Package Option Addendum at the end of this document, or see the TI website at [www.ti.com](http://www.ti.com).

### ABSOLUTE MAXIMUM RATINGS

over operating free-air temperature range (unless otherwise noted) <sup>(1)</sup>

		VALUE	UNIT
Supply Voltage Range <sup>(2)</sup>	V <sub>CC</sub> , V <sub>DD</sub>	-0.3 to 5.5	V
Voltage Range	Main Link I/O (ML_IN x, ML_OUT x) Differential Voltage	1.5	V
	HPD and CAD I/O	-0.3 to V <sub>CC</sub> + 0.3	V
	Control I/O	-0.3 to V <sub>CC</sub> + 0.3	V
Electrostatic discharge	Human body model <sup>(3)</sup>	±12000	V
	Charged-device model <sup>(4)</sup>	±1000	V
	Machine model <sup>(5)</sup>	±200	V
Continuous power dissipation		See Dissipation Rating Table	

(1) Stresses beyond those listed under absolute maximum ratings may cause permanent damage to the device. These are stress ratings only and functional operation of the device at these or any conditions beyond those indicated under recommended operating conditions is not implied. Exposure to absolute-maximum-rated conditions for extended periods may affect device reliability.

(2) All voltage values, except differential voltages, are with respect to network ground terminal.

(3) Tested in accordance with JEDEC Standard 22, Test Method A114-B.

(4) Tested in accordance with JEDEC Standard 22, Test Method C101-A.

(5) Tested in accordance with JEDEC Standard 22, Test Method A115-A.

### DISSIPATION RATINGS

PACKAGE	PCB JEDEC STANDARD	T <sub>A</sub> < 25°C	DERATING FACTOR <sup>(1)</sup> ABOVE T <sub>A</sub> = 25°C	T <sub>A</sub> = 85°C POWER RATING
36-pin QFN (RHH)	Low-K	759 mW	7.5 mW/°C	303 mW
	High-K	2127 mW	21.2 mW/°C	851 mW

(1) This is the inverse of the junction-to-ambient thermal resistance when board-mounted and with no air flow.

### THERMAL CHARACTERISTICS

over operating free-air temperature range (unless otherwise noted)

PARAMETER	TEST CONDITIONS	MIN	TYP	MAX <sup>(1)</sup>	UNIT
R <sub>θJB</sub> Junction-to-board thermal resistance	4x4 Thermal vias under powerpad		28.11		°C/W
R <sub>θJC</sub> Junction-to-case thermal resistance			32.77		°C/W
P <sub>D</sub> Device power dissipation	L <sub>P</sub> = 5.5 V; ML: V <sub>PP</sub> = 1200 mV, 2.7 Gbps, PRBS; HPD_IN/CAD_IN/CAD_INV = 5.5 V; V <sub>CC</sub> = 5.5 V, V <sub>DD</sub> = 5.25 V; Temp = 85°C; DP <sub>adj</sub> = 6.49 kΩ		240	280	mW
P <sub>SD</sub> Device power dissipation under low power	L <sub>P</sub> = 0V; HPD_IN/CAD_IN/CAD_INV = 5.5V; V <sub>CC</sub> = 5.5V, V <sub>DD</sub> = 5.2 V; Temp = 85°C; DP <sub>adj</sub> = 6.49 kΩ			40	μW

(1) Maximum Rating is simulated under worse case condition.

## RECOMMENDED OPERATING CONDITIONS

over operating free-air temperature range (unless otherwise noted)

		MIN	NOM	MAX	UNIT
$V_{CC}$	Supply Voltage	4.5	5	5.5	V
$V_{DD}$	HPD and CAD Output reference voltage	1.62		5.25	V
$T_A$	Operating free-air temperature	0		85	°C
<b>MAIN LINK DIFFERENTIAL PINS</b>					
$V_{ID}$	Peak-to-peak input differential voltage	0.15		1.40	V
$d_R$	Data rate			2.7	Gbps
$R_t$	Termination resistance	45	50	55	$\Omega$
$V_{O(term)}$	Output termination voltage	0		2	V
<b>HPD, CAD, AND CONTROL PINS</b>					
$V_{IH}$	High-level input voltage	2		5.5	V
$V_{IL}$	Low-level input Voltage	0		0.8	V

## DEVICE POWER

The SN75DP118 is designed to operate off of a single 5V supply.

## ELECTRICAL CHARACTERISTICS

over recommended operating conditions (unless otherwise noted)

PARAMETER	TEST CONDITIONS	MIN	TYP	MAX	UNIT
$I_{CC}$	Supply current $\overline{LP} = 5.5$ V; ML: $V_{PP} = 1200$ mV, 2.7 Gbps, PRBS; HPD_IN/CAD_IN/CAD_INV = 5.5 V; $V_{CC} = 5.5$ V, $V_{DD} = 5.25$ V; Temp = 85°C; $DP_{adj} = 6.49$ k $\Omega$		50	55	mA
$I_{DD}$	Supply current $V_{DD} = 5.5$ V		0.1	2	mA
$I_{SD}$	Shutdown current $\overline{LP} = 0$ V; HPD_IN/CAD_IN/CAD_INV = 5.5 V; $V_{CC} = 5.5$ V, $V_{DD} = 5.25$ V; Temp = 85°C; $DP_{adj} = 6.49$ k $\Omega$		4	10	$\mu$ A

## HOT PLUG AND CABLE ADAPTER DETECT

The SN75DP118 has a built in level shifter for the HPD and CAD outputs. The output voltage level of the HPD and CAD pins is defined by the voltage level of the VDD pin. The state of the HPD pin will also set the active state of the device. If HPD is low the device will enter low power mode. Once HPD goes high, the device will come out of low power mode and enter active mode. If HPD goes LOW for a period of time exceeding  $t_{T(HPD)}$ , the device will enter the low power mode.

## ELECTRICAL CHARACTERISTICS

over recommended operating (unless otherwise noted)

PARAMETER	TEST CONDITIONS	MIN	TYP	MAX	UNIT				
$V_{OH5}$	High-level output voltage	$I_{OH} = -100$ $\mu$ A, $V_{DD} = 5$ V	4.5	5	V				
$V_{OH3.3}$						$I_{OH} = -100$ $\mu$ A, $V_{DD} = 3.3$ V	3	3.3	V
$V_{OH2.5}$						$I_{OH} = -100$ $\mu$ A, $V_{DD} = 2.5$ V	2.25	2.5	V
$V_{OH1.8}$						$I_{OH} = -100$ $\mu$ A, $V_{DD} = 1.8$ V	1.62	1.8	V
$V_{OL}$	Low-level output voltage	$I_{OH} = 100$ $\mu$ A	0	0.4	V				
$I_H$	High-level input current	$V_{IH} = 2$ V, $V_{CC} = 5.5$ V	-10	10	$\mu$ A				
$I_L$	Low-level input current	$V_{IL} = 0.8$ V, $V_{CC} = 5.5$ V	-10	10	$\mu$ A				

### SWITCHING CHARACTERISTICS

over recommended operating (unless otherwise noted)

PARAMETER	TEST CONDITIONS	MIN	TYP	MAX	UNIT
$t_{PD(CAD)}$ Propagation delay	$V_{DD} = 5\text{ V}$		20	30	ns
$t_{PD(HPD)}$ Propagation delay	$V_{DD} = 5\text{ V}$		70	110	ns
$t_{T(HPD)}$ HPD logic switch time	$V_{DD} = 5\text{ V}$	200		400	ms
$t_{M(HPD)}$ Minimum output pulse duration	$V_{DD} = 5\text{ V}$	100			ns
$t_{Z(HPD)}$ Low power to high-level propagation delay	$V_{DD} = 5\text{ V}$		70	110	ns

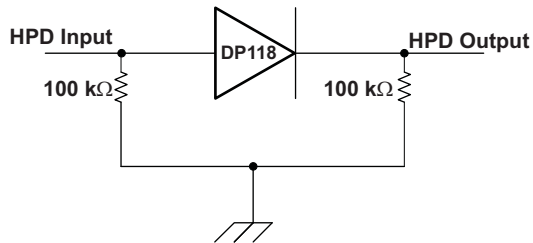

Figure 1. HPD Test Circuit

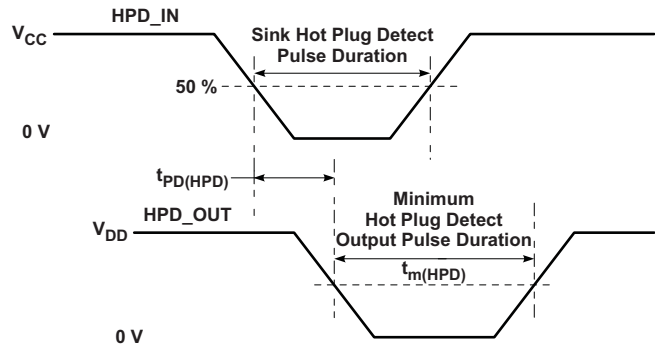

Figure 2. HPD Timing Diagram #1

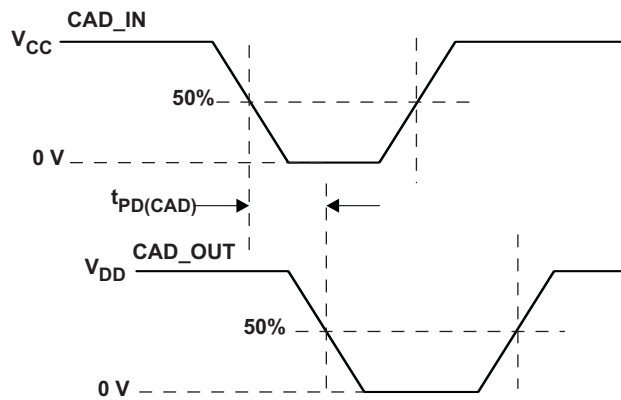

Figure 3. CAD Timing Diagram

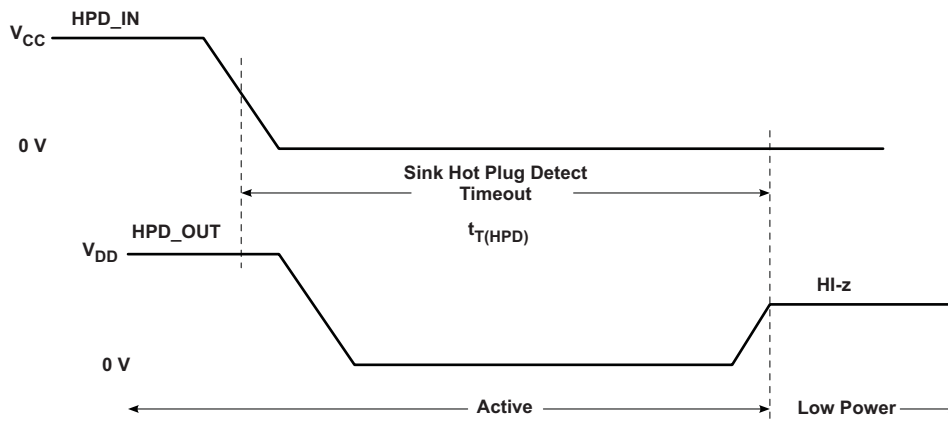

Figure 4. HPD Timing Diagram Number 2

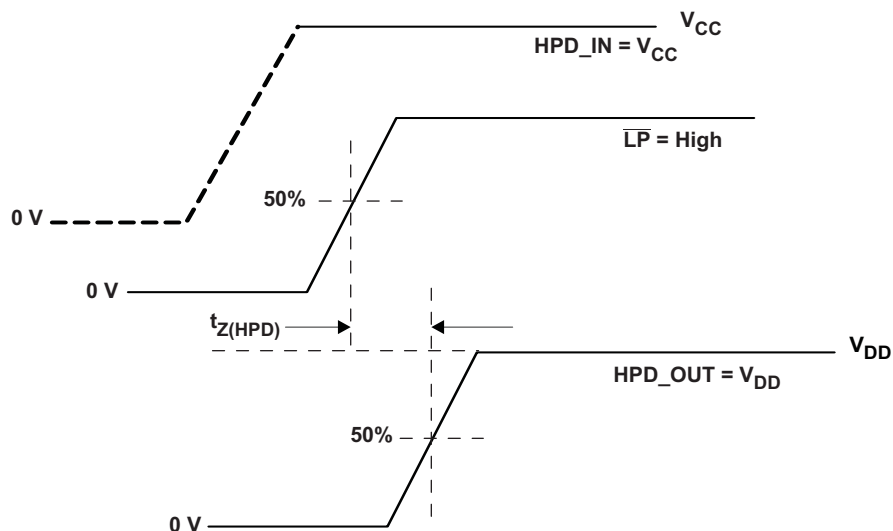

Figure 5. HPD Timing Diagram Number 3

### MAIN LINK PINS

The main link I/O of the SN75DP118 is designed to track the magnitude and frequency characteristics of the input waveform and replicate them on the output. A feature has also been incorporated in the SN75DP118 to either increase or decrease the output amplitude via the resistor connected between the DP<sub>adj</sub> pin and ground.

### ELECTRICAL CHARACTERISTICS

over recommended operating (unless otherwise noted)

PARAMETER		TEST CONDITIONS	MIN	TYP	MAX	UNIT
$\Delta V_{I/O(2)}$	Difference between input and output voltages ( $V_{OD} - V_{ID}$ )	$V_{ID} = 200 \text{ mV}$ , $DP_{adj} = 6.5 \text{ k}\Omega$	0	30	60	mV
$\Delta V_{I/O(3)}$		$V_{ID} = 300 \text{ mV}$ , $DP_{adj} = 6.5 \text{ k}\Omega$	-24	11	36	
$\Delta V_{I/O(4)}$		$V_{ID} = 400 \text{ mV}$ , $DP_{adj} = 6.5 \text{ k}\Omega$	-45	-15	15	
$\Delta V_{I/O(6)}$		$V_{ID} = 600 \text{ mV}$ , $DP_{adj} = 6.5 \text{ k}\Omega$	-87	-47	-22	
$R_{INT}$	Input termination impedance		45	50	55	$\Omega$
$V_{Iterm}$	Input termination voltage		0		2	V

### SWITCHING CHARACTERISTICS

over recommended operating (unless otherwise noted)

PARAMETER		TEST CONDITIONS	MIN	TYP	MAX	UNIT
$t_{R/F(DP)}$	Output edge rate (20% - 80%)	Input edge rate = 80 ps (20% - 80%)		115		ps
$t_{PD}$	Propagation delay time	$F = 1\text{MHz}$ , $V_{ID} = 400 \text{ mV}$	200	240	280	ps
$t_{SK(1)}$	Intra-pair skew	$F = 1\text{MHz}$ , $V_{ID} = 400 \text{ mV}$			20	ps
$t_{SK(2)}$	Inter-pair skew	$F = 1\text{MHz}$ , $V_{ID} = 400 \text{ mV}$			40	ps
$t_{DPJIT(PP)}$	Peak-to-peak output residual jitter	$dR = 2.7\text{Gbps}$ , $V_{ID} = 400 \text{ mV}$ , PRBS7		25	35	ps

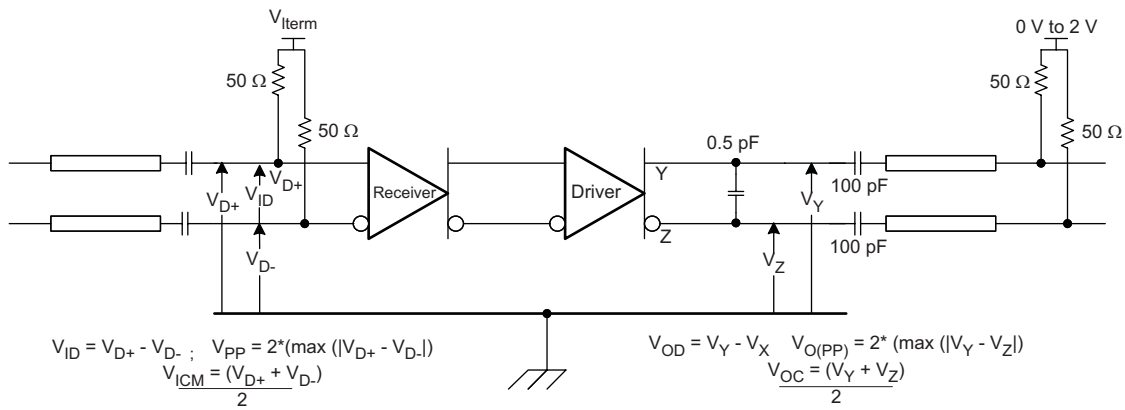

Figure 6. Main Link Test Circuit

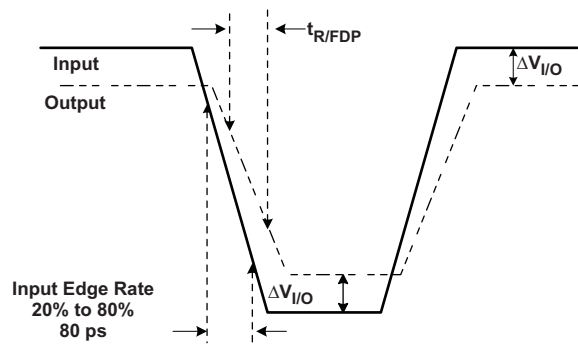

Figure 7. Main Link  $\Delta V_{I/O}$  and Edge Rate Measurements

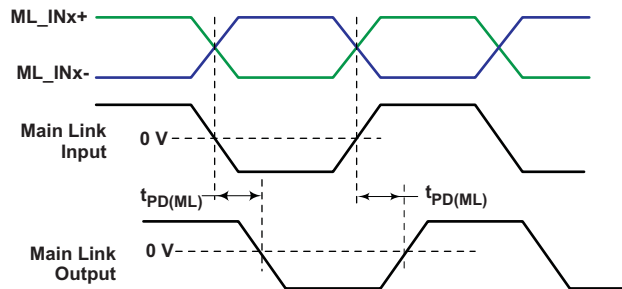

Figure 8. Main Link Delay Measurements

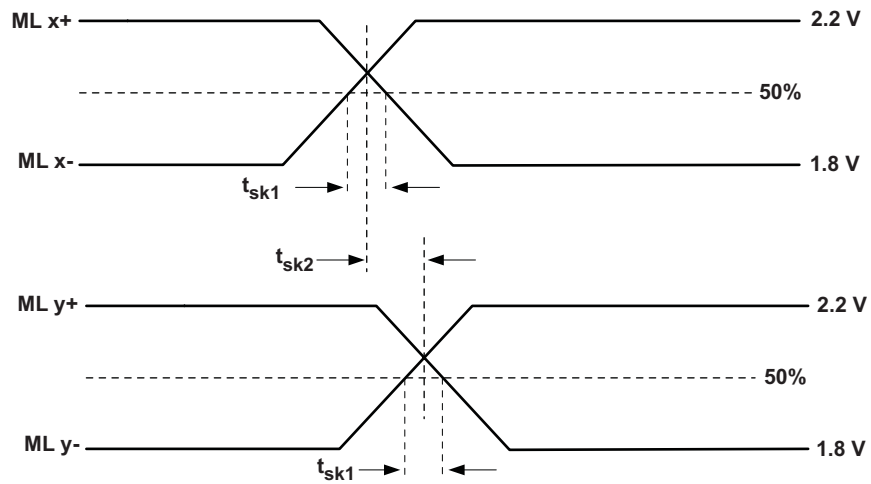

Figure 9. Main Link Skew Measurements

TYPICAL CHARACTERISTICS

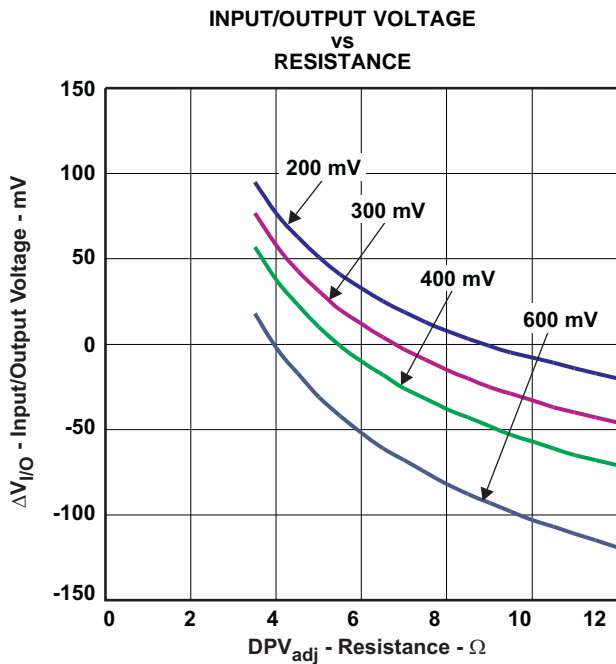

Figure 10.

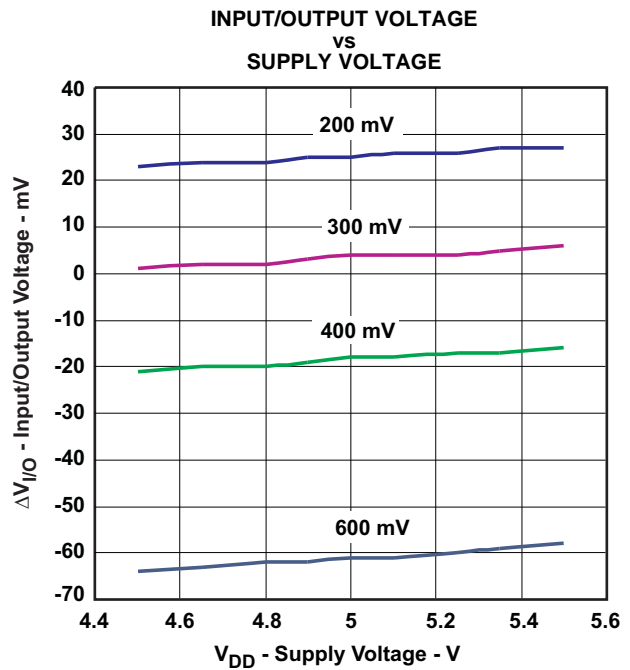

Figure 11.

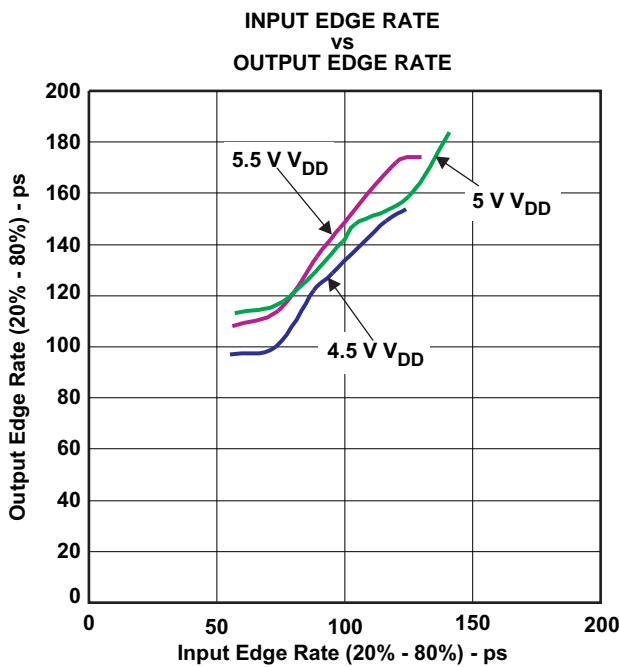

Figure 12.

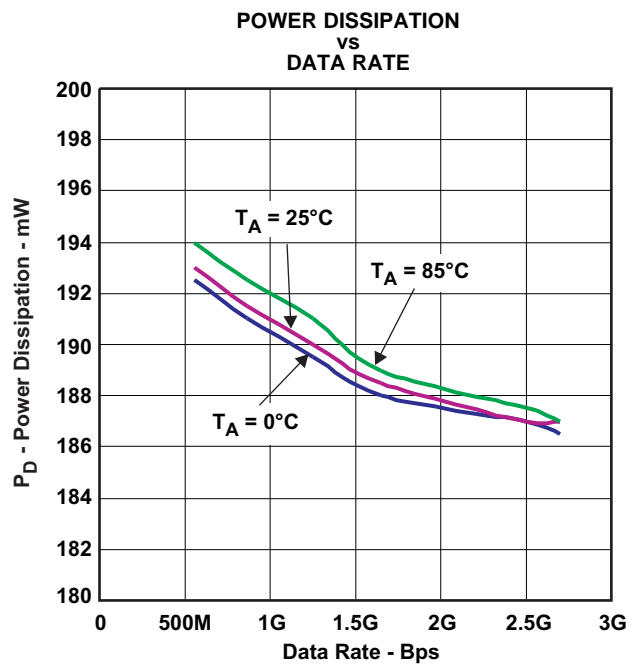

Figure 13.

## APPLICATION INFORMATION

### Power Logic

The power logic of the SN75DP118 is tied to the state of the HPD input pin as well as the low power pin. When HPD\_IN is LOW the SN75DP118 enters the low power state. In this state the outputs are high impedance and the device shuts down to optimize power conservation. When HPD\_IN goes high the device enters the normal operational state.

Several key factors were taken into consideration with this digital logic implementation of channel selection, as well as HPD repeating. This logic is described in the following scenarios.

Scenario 1. Low Power State to Active State:

- There are two possible cases for this scenario depending on the state of the low power pin.
  - Case one: In this case HPD\_IN is initially LOW and the low power pin is also LOW. In this initial state the device is in a low power mode. Once the HPD input goes to a HIGH state the device remains in the low power mode, with both the main link and auxiliary I/O in a high impedance state (Figure 14).
  - Case two: In this case HPD\_IN is initially LOW and the low power pin is HIGH. In this initial state the device is in a low power mode. Once the HPD input goes to a HIGH state the device comes out of the low power mode and enters active mode, enabling the main link and auxiliary I/O. The HPD output to the source is enabled and follows the logic state of the input HPD (Figure 15). This is specified as  $t_{Z(HPD)}$ .

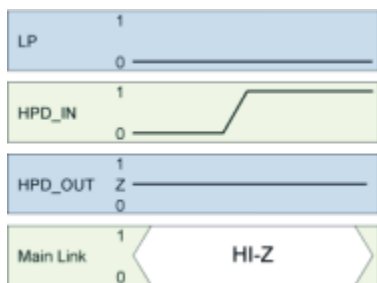

Figure 14.

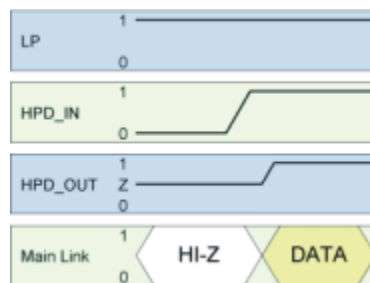

Figure 15.

Scenario 2. HPD Changes:

- In this case the HPD input is initially HIGH. The HPD output logic state follows the state of the HPD input. If the HPD input pulses LOW, as may be the case if the sink device is requesting an interrupt, the HPD output to the source will also pulse Low for the same duration of time with a slight delay (Figure 16). The delay of this signal through the SN75DP118 is specified as  $t_{PD(HPD)}$ . If the duration of the LOW pulse is less than  $t_{M(HPD)}$  it may not be accurately repeated to the source. If the duration of the LOW pulse exceeds  $t_{T(HPD)}$  the device determines that an unplug event has occurred and enters the low power state (Figure 17). Once the HPD input goes high again the device returns to the active state as indicated in scenario 1.

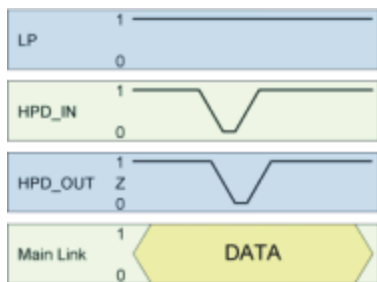

Figure 16.

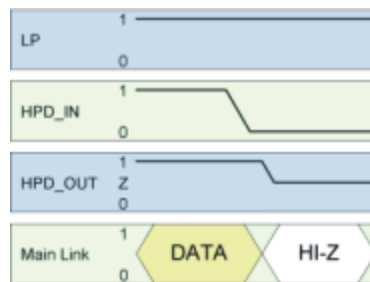

Figure 17.

**PACKAGING INFORMATION**

Orderable Device	Status (1)	Package Type	Package Drawing	Pins	Package Qty	Eco Plan (2)	Lead finish/ Ball material (6)	MSL Peak Temp (3)	Op Temp (°C)	Device Marking (4/5)	Samples
SN75DP118RHHR	ACTIVE	VQFN	RHH	36	2500	RoHS & Green	NIPDAU	Level-3-260C-168 HR	0 to 85	DP118	<a href="#">Samples</a>
SN75DP118RHHT	ACTIVE	VQFN	RHH	36	250	RoHS & Green	NIPDAU	Level-3-260C-168 HR	0 to 85	DP118	<a href="#">Samples</a>

(1) The marketing status values are defined as follows:

**ACTIVE:** Product device recommended for new designs.

**LIFEBUY:** TI has announced that the device will be discontinued, and a lifetime-buy period is in effect.

**NRND:** Not recommended for new designs. Device is in production to support existing customers, but TI does not recommend using this part in a new design.

**PREVIEW:** Device has been announced but is not in production. Samples may or may not be available.

**OBSOLETE:** TI has discontinued the production of the device.

(2) **RoHS:** TI defines "RoHS" to mean semiconductor products that are compliant with the current EU RoHS requirements for all 10 RoHS substances, including the requirement that RoHS substance do not exceed 0.1% by weight in homogeneous materials. Where designed to be soldered at high temperatures, "RoHS" products are suitable for use in specified lead-free processes. TI may reference these types of products as "Pb-Free".

**RoHS Exempt:** TI defines "RoHS Exempt" to mean products that contain lead but are compliant with EU RoHS pursuant to a specific EU RoHS exemption.

**Green:** TI defines "Green" to mean the content of Chlorine (Cl) and Bromine (Br) based flame retardants meet JS709B low halogen requirements of <=1000ppm threshold. Antimony trioxide based flame retardants must also meet the <=1000ppm threshold requirement.

(3) MSL, Peak Temp. - The Moisture Sensitivity Level rating according to the JEDEC industry standard classifications, and peak solder temperature.

(4) There may be additional marking, which relates to the logo, the lot trace code information, or the environmental category on the device.

(5) Multiple Device Markings will be inside parentheses. Only one Device Marking contained in parentheses and separated by a "~" will appear on a device. If a line is indented then it is a continuation of the previous line and the two combined represent the entire Device Marking for that device.

(6) Lead finish/Ball material - Orderable Devices may have multiple material finish options. Finish options are separated by a vertical ruled line. Lead finish/Ball material values may wrap to two lines if the finish value exceeds the maximum column width.

**Important Information and Disclaimer:**The information provided on this page represents TI's knowledge and belief as of the date that it is provided. TI bases its knowledge and belief on information provided by third parties, and makes no representation or warranty as to the accuracy of such information. Efforts are underway to better integrate information from third parties. TI has taken and continues to take reasonable steps to provide representative and accurate information but may not have conducted destructive testing or chemical analysis on incoming materials and chemicals. TI and TI suppliers consider certain information to be proprietary, and thus CAS numbers and other limited information may not be available for release.

In no event shall TI's liability arising out of such information exceed the total purchase price of the TI part(s) at issue in this document sold by TI to Customer on an annual basis.

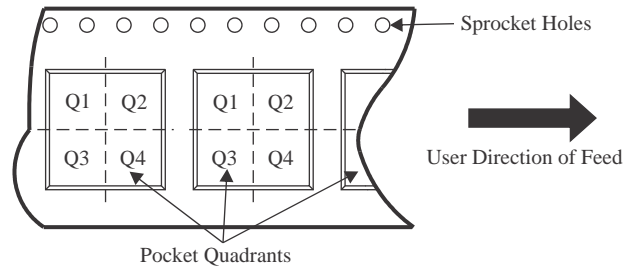

**TAPE AND REEL INFORMATION**

**QUADRANT ASSIGNMENTS FOR PIN 1 ORIENTATION IN TAPE**

\*All dimensions are nominal

Device	Package Type	Package Drawing	Pins	SPQ	Reel Diameter (mm)	Reel Width W1 (mm)	A0 (mm)	B0 (mm)	K0 (mm)	P1 (mm)	W (mm)	Pin1 Quadrant
SN75DP118RHHR	VQFN	RHH	36	2500	330.0	16.4	6.3	6.3	1.1	12.0	16.0	Q2
SN75DP118RHHT	VQFN	RHH	36	250	180.0	16.4	6.3	6.3	1.1	12.0	16.0	Q2

**TAPE AND REEL BOX DIMENSIONS**

\*All dimensions are nominal

Device	Package Type	Package Drawing	Pins	SPQ	Length (mm)	Width (mm)	Height (mm)
SN75DP118RHHR	VQFN	RHH	36	2500	356.0	356.0	35.0
SN75DP118RHHT	VQFN	RHH	36	250	210.0	185.0	35.0

## GENERIC PACKAGE VIEW

**RHH 36**

**VQFN - 1 mm max height**

6 x 6, 0.5 mm pitch

PLASTIC QUAD FLATPACK - NO LEAD

This image is a representation of the package family, actual package may vary.  
Refer to the product data sheet for package details.

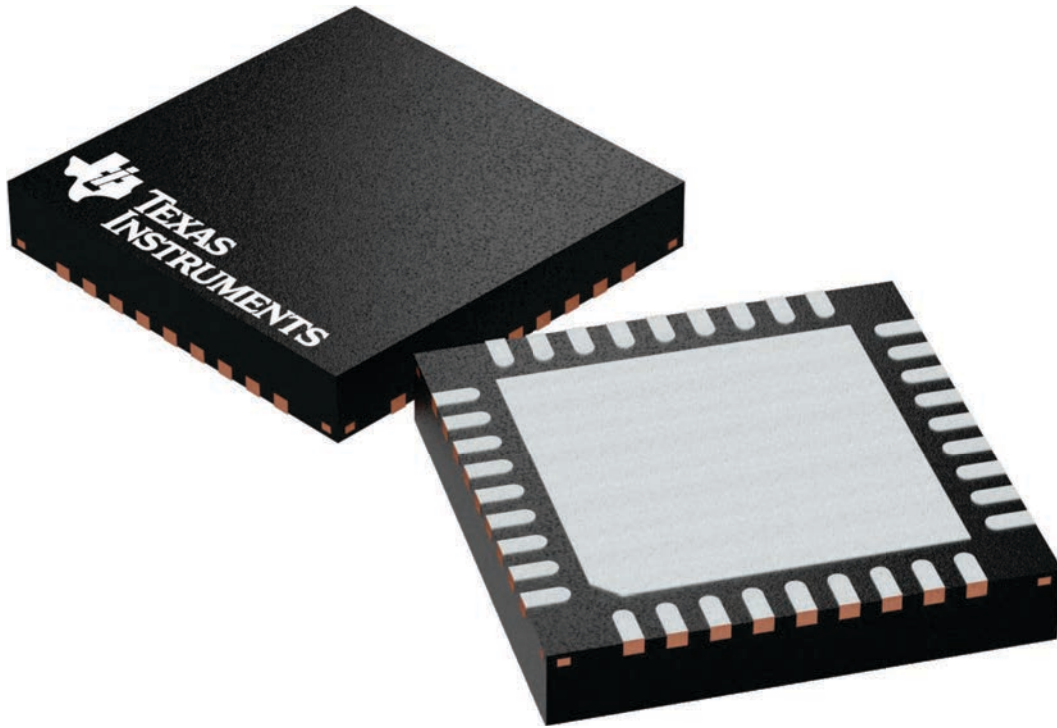

4225440/A

RHH0036B

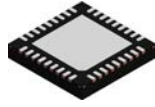

# PACKAGE OUTLINE

VQFN - 1 mm max height

PLASTIC QUAD FLATPACK - NO LEAD

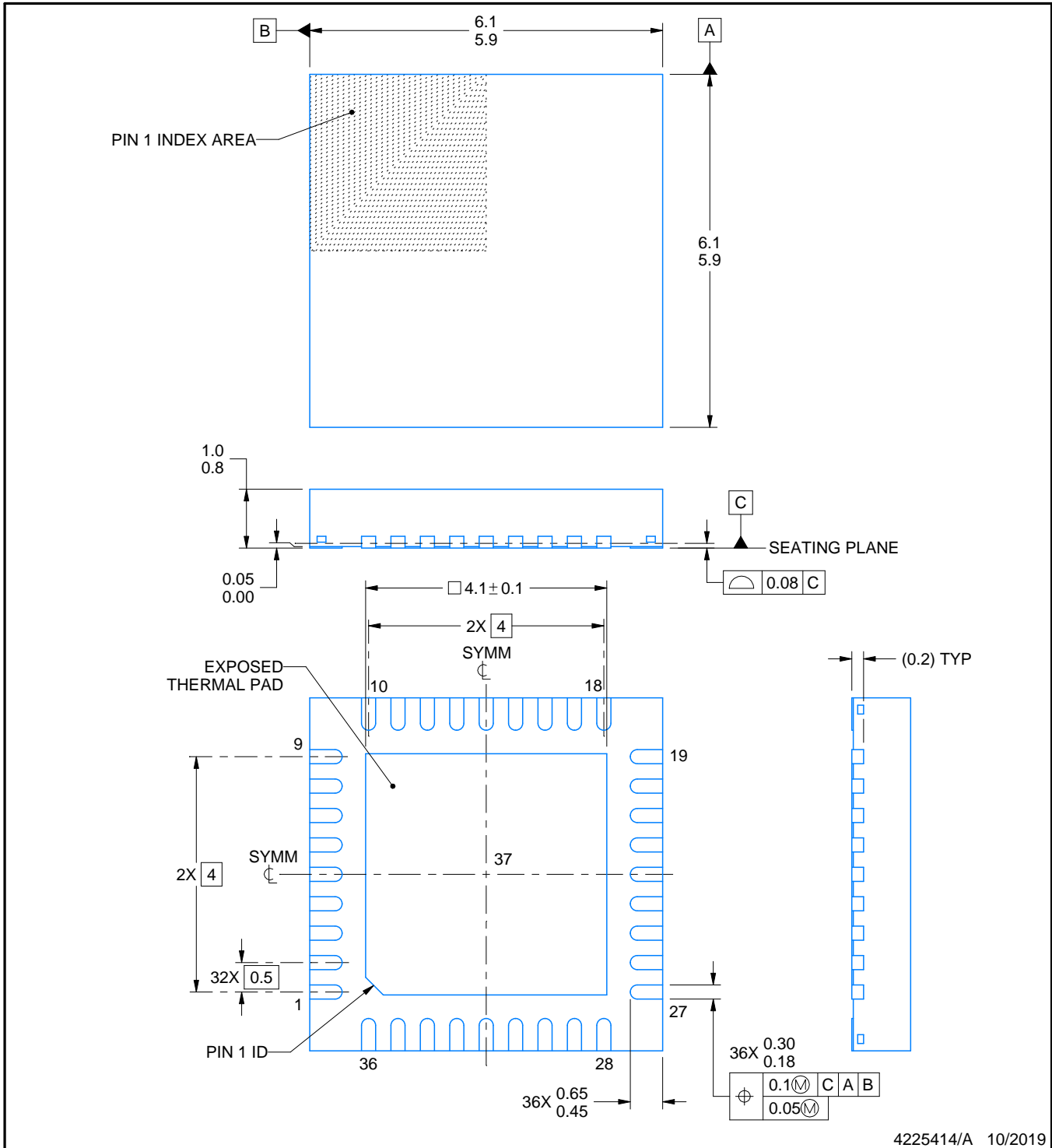

NOTES:

1. All linear dimensions are in millimeters. Any dimensions in parenthesis are for reference only. Dimensioning and tolerancing per ASME Y14.5M.
2. This drawing is subject to change without notice.
3. The package thermal pad must be soldered to the printed circuit board for thermal and mechanical performance.

# EXAMPLE BOARD LAYOUT

RHH0036B

VQFN - 1 mm max height

PLASTIC QUAD FLATPACK - NO LEAD

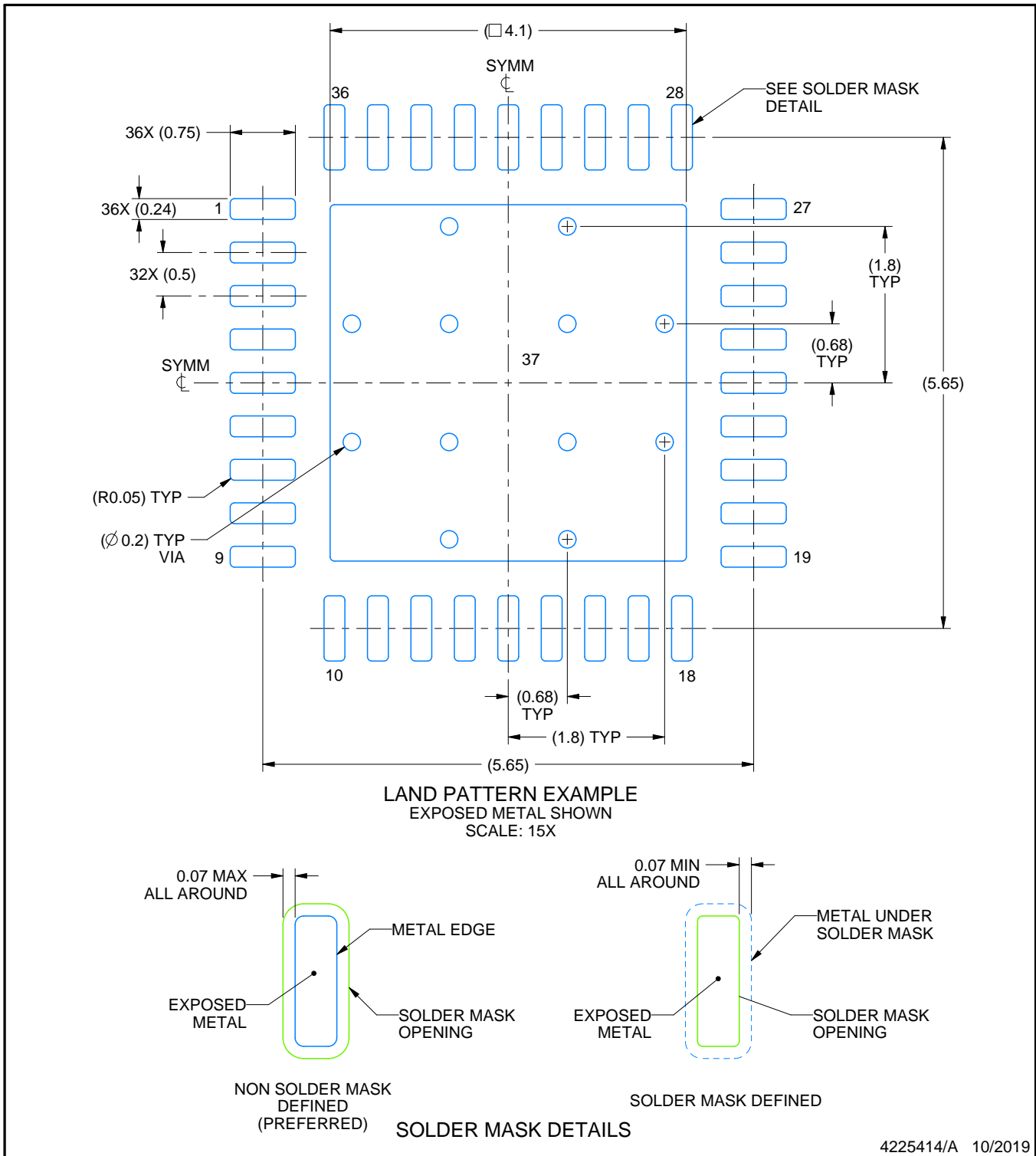

4225414/A 10/2019

NOTES: (continued)

4. This package is designed to be soldered to a thermal pad on the board. For more information, see Texas Instruments literature number SLUA271 ([www.ti.com/lit/sluea271](http://www.ti.com/lit/sluea271)).
5. Vias are optional depending on application, refer to device data sheet. If any vias are implemented, refer to their locations shown on this view. It is recommended that vias under paste be filled, plugged or tented.

# EXAMPLE STENCIL DESIGN

RHH0036B

VQFN - 1 mm max height

PLASTIC QUAD FLATPACK - NO LEAD

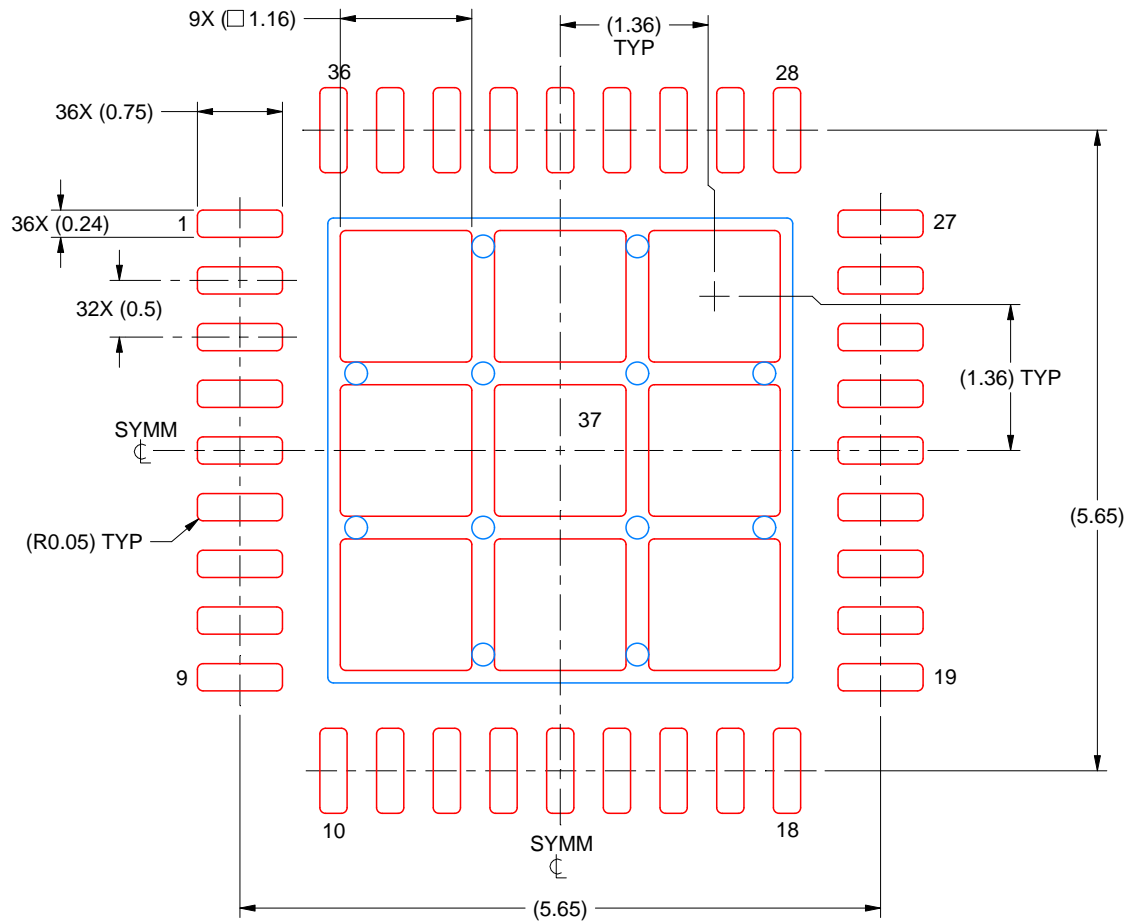

SOLDER PASTE EXAMPLE  
BASED ON 0.125 MM THICK STENCIL  
SCALE: 15X

EXPOSED PAD 37  
72% PRINTED SOLDER COVERAGE BY AREA UNDER PACKAGE

4225414/A 10/2019

NOTES: (continued)

6. Laser cutting apertures with trapezoidal walls and rounded corners may offer better paste release. IPC-7525 may have alternate design recommendations.

## IMPORTANT NOTICE AND DISCLAIMER

TI PROVIDES TECHNICAL AND RELIABILITY DATA (INCLUDING DATA SHEETS), DESIGN RESOURCES (INCLUDING REFERENCE DESIGNS), APPLICATION OR OTHER DESIGN ADVICE, WEB TOOLS, SAFETY INFORMATION, AND OTHER RESOURCES "AS IS" AND WITH ALL FAULTS, AND DISCLAIMS ALL WARRANTIES, EXPRESS AND IMPLIED, INCLUDING WITHOUT LIMITATION ANY IMPLIED WARRANTIES OF MERCHANTABILITY, FITNESS FOR A PARTICULAR PURPOSE OR NON-INFRINGEMENT OF THIRD PARTY INTELLECTUAL PROPERTY RIGHTS.

These resources are intended for skilled developers designing with TI products. You are solely responsible for (1) selecting the appropriate TI products for your application, (2) designing, validating and testing your application, and (3) ensuring your application meets applicable standards, and any other safety, security, regulatory or other requirements.

These resources are subject to change without notice. TI grants you permission to use these resources only for development of an application that uses the TI products described in the resource. Other reproduction and display of these resources is prohibited. No license is granted to any other TI intellectual property right or to any third party intellectual property right. TI disclaims responsibility for, and you will fully indemnify TI and its representatives against, any claims, damages, costs, losses, and liabilities arising out of your use of these resources.

TI's products are provided subject to [TI's Terms of Sale](#) or other applicable terms available either on [ti.com](http://ti.com) or provided in conjunction with such TI products. TI's provision of these resources does not expand or otherwise alter TI's applicable warranties or warranty disclaimers for TI products.

TI objects to and rejects any additional or different terms you may have proposed.

Mailing Address: Texas Instruments, Post Office Box 655303, Dallas, Texas 75265  
Copyright © 2022, Texas Instruments Incorporated

## Looking for pricing, stock, or lifecycle information?

Click below to explore more details on WIN SOURCE:

 [View SN75DP118RHHT on WIN SOURCE](#)

 [Texas Instruments](#) Information

## Optimize Your Supply Chain with WIN SOURCE Solutions

-  Global Sourcing Solution
-  Obsolete Management
-  Cost Control Management
-  Shortage Management
-  Alternative Solution
-  Excess Inventory Management