



**THE DATASHEET OF
SN75ALS160DWG4**



SN75ALS160

OCTAL GENERAL-PURPOSE INTERFACE BUS TRANSCEIVERS

SLLS018E – JUNE 1986 – REVISED JUNE 2004

- Suitable for IEEE Standard 488-1978 (GPIB)
- 8-Channel Bidirectional Transceivers
- High-Speed Advanced Low-Power Schottky (ALS) Circuitry
- Low Power Dissipation
... 46 mW Max Per Channel
- Fast Propagation Times ... 20 ns Max
- High-Impedance pnp Inputs
- Receiver Hysteresis ... 650 mV Typ
- Open-Collector Driver Output Option
- No Loading of Bus When Device Is Powered Down ($V_{CC} = 0$)
- Power-Up/Power-Down Protection (Glitch Free)

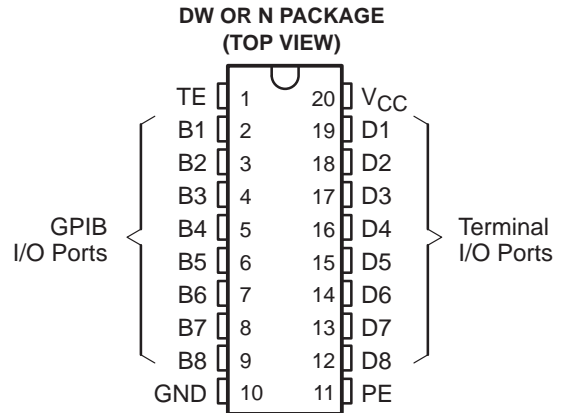

description/ordering information

The SN75ALS160 eight-channel general-purpose interface bus transceivers are monolithic, high-speed, advanced low-power Schottky (ALS) devices designed for two-way data communications over single-ended transmission lines. This device is designed to meet the requirements of IEEE Standard 488-1978. The transceivers feature driver outputs that can be operated in either the passive-pullup or 3-state mode. If talk enable (TE) is high, these ports have the characteristics of passive-pullup outputs when pullup enable (PE) is low and of 3-state outputs when PE is high. Taking TE low places these ports in the high-impedance state. The driver outputs are designed to handle loads up to 48 mA of sink current.

An active turn-off feature has been incorporated into the bus-terminating resistors so that the device exhibits a high impedance to the bus when $V_{CC} = 0$. When combined with the SN75ALS161 or SN75ALS162 bus management transceiver, the pair provides the complete 16-wire interface for the IEEE-488 bus.

The SN75ALS160 is characterized for operation from 0°C to 70°C.

ORDERING INFORMATION

T _A	PACKAGE†		ORDERABLE PART NUMBER	TOP-SIDE MARKING
0°C to 70°C	PDIP (N)	Tube of 20	SN75ALS160N	SN75ALS160N
	SOIC (DW)	Tube of 25	SN75ALS160DW	75ALS160
		Reel of 2000	SN75ALS160DWR	

† Package drawings, standard packing quantities, thermal data, symbolization, and PCB design guidelines are available at www.ti.com/sc/package.



Please be aware that an important notice concerning availability, standard warranty, and use in critical applications of Texas Instruments semiconductor products and disclaimers thereto appears at the end of this data sheet.

PRODUCTION DATA information is current as of publication date. Products conform to specifications per the terms of Texas Instruments standard warranty. Production processing does not necessarily include testing of all parameters.

**TEXAS
INSTRUMENTS**

POST OFFICE BOX 655303 • DALLAS, TEXAS 75265

Copyright © 2004, Texas Instruments Incorporated

SN75ALS160 OCTAL GENERAL-PURPOSE INTERFACE BUS TRANSCEIVERS

SLLS018E – JUNE 1986 – REVISED JUNE 2004

Function Tables

EACH DRIVER

INPUTS			OUTPUT
D	TE	PE	B
H	H	H	H
L	H	X	L
H	X	L	Z†
X	L	X	Z†

EACH RECEIVER

INPUTS			OUTPUT
B	TE	PE	D
L	L	X	L
H	L	X	H
X	H	X	Z

H = high level, L = low level, X = irrelevant,
Z = high-impedance state

† This is the high-impedance state of a normal 3-state output modified by the internal resistors to V_{CC} and GND.

logic diagram (positive logic)

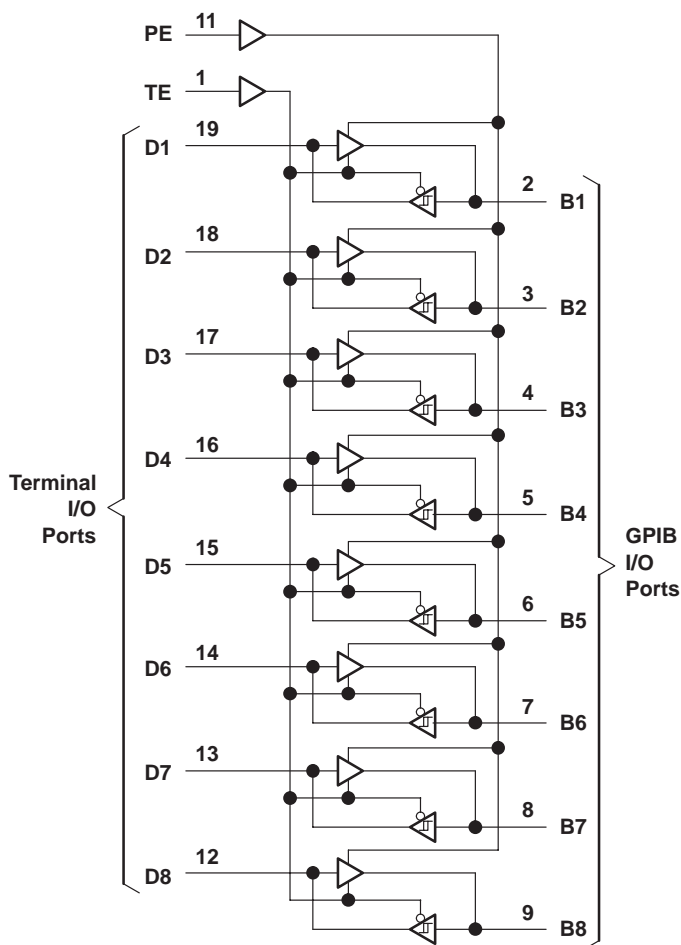

SN75ALS160 OCTAL GENERAL-PURPOSE INTERFACE BUS TRANSCEIVERS

SLLS018E – JUNE 1986 – REVISED JUNE 2004

schematics of inputs and outputs

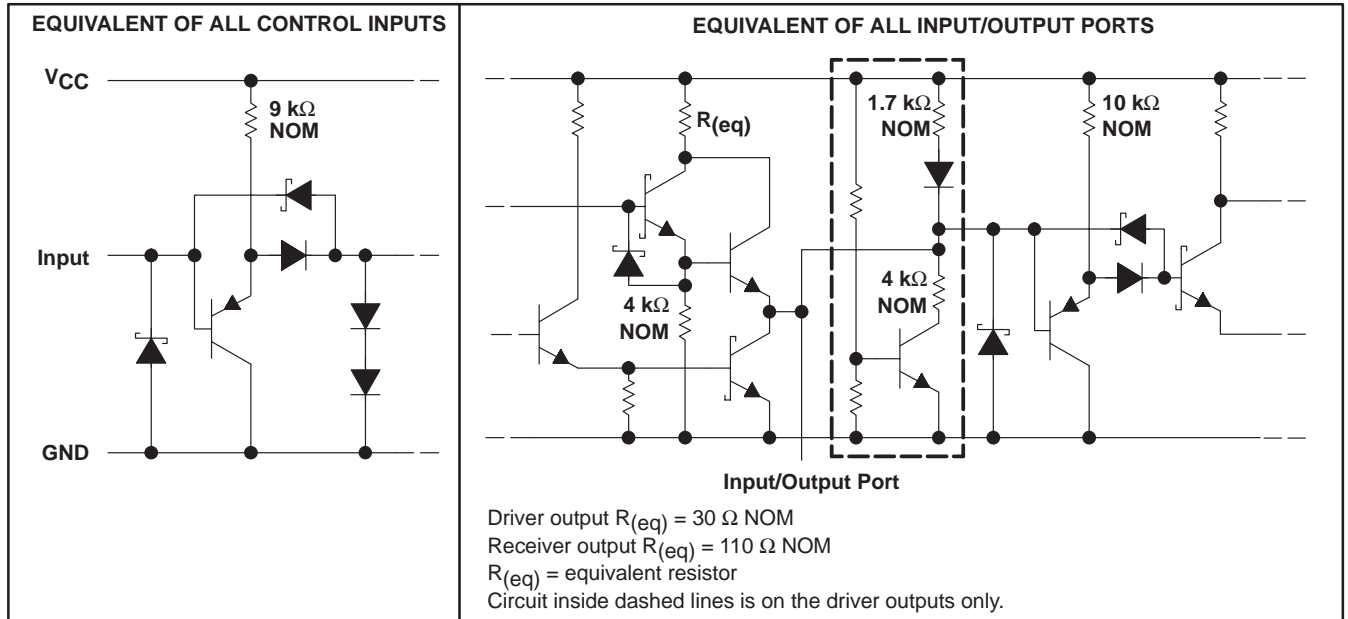

absolute maximum ratings over operating free-air temperature range (unless otherwise noted)†

Supply voltage, V_{CC} (see Note 1)	7 V
Input voltage, V_I	5.5 V
Low-level driver output current, I_{OL}	100 mA
Package thermal impedance, θ_{JA} (see Notes 2 and 3): DW package	58°C/W
N package	69°C/W
Operating virtual junction temperature, T_J	150°C
Storage temperature range, T_{STG}	-65°C to 150°C

† Stresses beyond those listed under "absolute maximum ratings" may cause permanent damage to the device. These are stress ratings only, and functional operation of the device at these or any other conditions beyond those indicated under "recommended operating conditions" is not implied. Exposure to absolute-maximum-rated conditions for extended periods may affect device reliability.

- NOTES:
1. All voltage values are with respect to network ground terminal.
 2. Maximum power dissipation is a function of $T_J(\max)$, θ_{JA} , and T_A . The maximum allowable power dissipation at any allowable ambient temperature is $P_D = (T_J(\max) - T_A) / \theta_{JA}$. Operating at the absolute maximum T_J of 150°C can affect reliability.
 3. The package thermal impedance is calculated in accordance with JESD 51-7.

SN75ALS160

OCTAL GENERAL-PURPOSE INTERFACE BUS TRANSCEIVERS

SLLS018E – JUNE 1986 – REVISED JUNE 2004

recommended operating conditions

		MIN	NOM	MAX	UNIT
V _{CC}	Supply voltage	4.75	5	5.25	V
V _{IH}	High-level input voltage	2			V
V _{IL}	Low-level input voltage			0.8	V
I _{OH}	High-level output current	Bus ports with pullups active		-5.2	mA
		Terminal ports		-800	μA
I _{OL}	Low-level output current	Bus ports		48	mA
		Terminal ports		16	
T _A	Operating free-air temperature	0		70	°C

electrical characteristics over recommended ranges of supply voltage and operating free-air temperature (unless otherwise noted)

PARAMETER		TEST CONDITIONST		MIN	TYP‡	MAX	UNIT		
V _{IK}	Input clamp voltage	I _I = -18 mA, V _{CC} = MIN		-0.8	-1.5		V		
V _{hys}	Hysteresis voltage (V _{IT+} - V _{IT-})	Bus		0.4	0.65		V		
V _{OH} §	High-level output voltage	Terminal	I _{OH} = -800 μA, TE at 0.8 V, V _{CC} = MIN	2.7	3.5		V		
		Bus	I _{OH} = -5.2 mA, PE and TE at 2 V, V _{CC} = MIN	2.5	3.3				
V _{OL}	Low-level output voltage	Terminal	I _{OL} = 16 mA, TE at 0.8 V, V _{CC} = MIN		0.3	0.5	V		
		Bus	I _{OL} = 48 mA, TE at 2 V, V _{CC} = MIN		0.35	0.5			
I _I	Input current at maximum input voltage	Terminal	V _I = 5.5 V, V _{CC} = MAX		0.2	100	μA		
I _{IH}	High-level input current	Terminal, PE, or TE	V _I = 2.7 V, V _{CC} = MAX		0.1	20	μA		
I _{IL}	Low-level input current	Terminal, PE, or TE	V _I = 0.5 V, V _{CC} = MAX		-10	-100	μA		
V _{I/O(bus)}	Voltage at bus port	I _{I(bus)} = 0		2.5	3	3.7	V		
		I _{I(bus)} = -12 mA				-1.5	V		
I _{I/O(bus)}	Current into bus port	Power on	V _{CC} = MAX	V _{I(bus)} = -1.5 V to 0.4 V		-1.3	mA		
				V _{I(bus)} = 0.4 V to 2.5 V		0		-3.2	
				V _{I(bus)} = 2.5 V to 3.7 V				2.5	-3.2
				V _{I(bus)} = 3.7 V to 5 V		0		2.5	
				V _{I(bus)} = 5 V to 5.5 V		0.7		2.5	
		Power off	V _{CC} = 0	V _{I(bus)} = 0 to 2.5 V				40	μA
I _{OS}	Short-circuit output current	Terminal	V _{CC} = MAX		-15	-35	-75	mA	
		Bus	V _{CC} = MAX		-25	-50	-125		
I _{CC}	Supply current	No load, V _{CC} = MAX	Terminal outputs low and enabled			42	65	mA	
			Bus outputs low and enabled			52	80		
C _{I/O(bus)}	Bus-port capacitance	V _{CC} = 0 to 5 V, V _{I/O} = 0 to 2 V, f = 1 MHz			30		pF		

† For conditions shown as MIN or MAX, use the appropriate value specified under recommended operating conditions.

‡ All typical values are at V_{CC} = 5 V, T_A = 25°C.

§ V_{OH} applies to 3-state outputs only.



SN75ALS160

OCTAL GENERAL-PURPOSE INTERFACE BUS TRANSCEIVERS

SLLS018E – JUNE 1986 – REVISED JUNE 2004

switching characteristics at $V_{CC} = 4.75\text{ V}$, 5 V , and 5.25 V , $T_A = 25^\circ\text{C}$ (unless otherwise noted)

PARAMETER		FROM (INPUT)	TO (OUTPUT)	TEST CONDITIONS	MIN	TYP†	MAX	UNIT
t _{PLH}	Propagation delay time, low- to high-level output	Terminal	Bus	See Figure 1, $C_L = 50\text{ pF}$		10	17	ns
t _{PHL}	Propagation delay time, high- to low-level output					10	14	
t _{PLH}	Propagation delay time, low- to high-level output	Bus	Terminal	See Figure 2, $C_L = 50\text{ pF}$		8	15	ns
t _{PHL}	Propagation delay time, high- to low-level output					8	15	
t _{PZH}	Output enable time to high level	TE	Bus	See Figure 3, $C_L = 50\text{ pF}$		24	30	ns
t _{PHZ}	Output disable time from high level					9	14	
t _{PZL}	Output enable time to low level					16	28	
t _{PLZ}	Output disable time from low level					12	19	
t _{PZH}	Output enable time to high level	TE	Terminal	See Figure 4, $C_L = 50\text{ pF}$		24	36	ns
t _{PHZ}	Output disable time from high level					10	18	
t _{PZL}	Output enable time to low level					15	26	
t _{PLZ}	Output disable time from low level					15	24	
t _{en}	Output pullup enable time	PE	Bus	See Figure 5, $C_L = 50\text{ pF}$		16	24	ns
t _{dis}	Output pullup disable time					9	16	

† All typical values are at $V_{CC} = 5\text{ V}$.

switching characteristics over recommended range of operating free-air temperature, $V_{CC} = 5\text{ V}$

PARAMETER		FROM (INPUT)	TO (OUTPUT)	TEST CONDITIONS	MIN	TYP‡	MAX	UNIT
t _{PLH}	Propagation delay time, low- to high-level output	Terminal	Bus	$C_L = 30\text{ pF}$, See Figure 1		7	20	ns
t _{PHL}	Propagation delay time, high- to low-level output					8	20	
t _{PLH}	Propagation delay time, low- to high-level output	Bus	Terminal	$C_L = 30\text{ pF}$, See Figure 2		7	14	ns
t _{PHL}	Propagation delay time, high- to low-level output					9	14	
t _{PZH}	Output enable time to high level	TE	Bus	$C_L = 15\text{ pF}$, See Figure 3		19	30	ns
t _{PHZ}	Output disable time from high level					5	12	
t _{PZL}	Output enable time to low level					16	35	
t _{PLZ}	Output disable time from low level					9	20	
t _{PZH}	Output enable time to high level	TE	Terminal	$C_L = 15\text{ pF}$, See Figure 4		13	30	ns
t _{PHZ}	Output disable time from high level					12	20	
t _{PZL}	Output enable time to low level					12	20	
t _{PLZ}	Output disable time from low level					11	20	
t _{en}	Output pullup enable time	PE	Bus	$C_L = 15\text{ pF}$, See Figure 5		11	22	ns
t _{dis}	Output pullup disable time					6	12	

‡ Typical values are at $T_A = 25^\circ\text{C}$.

SN75ALS160 OCTAL GENERAL-PURPOSE INTERFACE BUS TRANSCEIVERS

SLLS018E – JUNE 1986 – REVISED JUNE 2004

PARAMETER MEASUREMENT INFORMATION

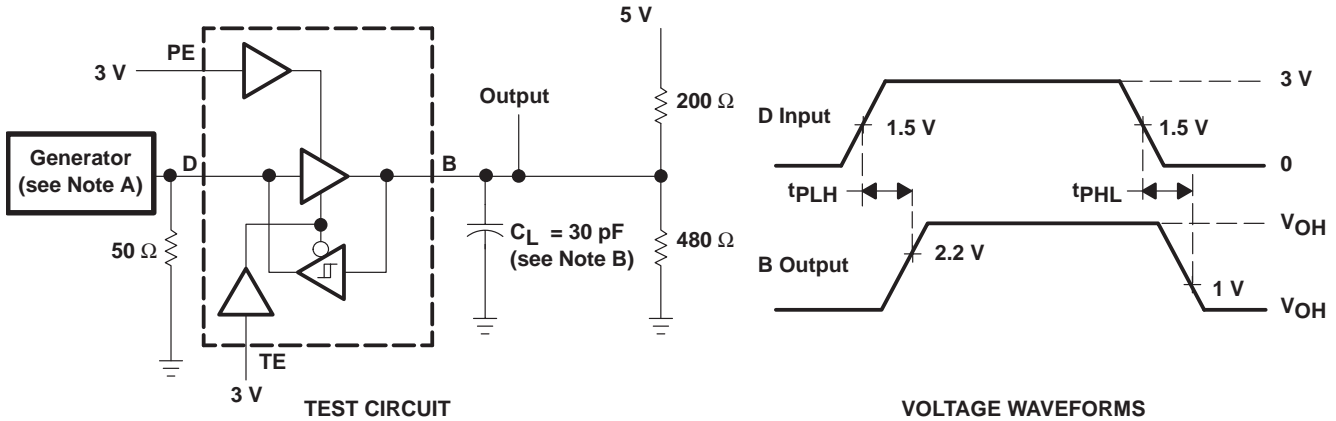

- NOTES: A. The input pulse is supplied by a generator having the following characteristics: $PRR \leq 1 \text{ MHz}$, 50% duty cycle, $t_r \leq 6 \text{ ns}$, $t_f \leq 6 \text{ ns}$, $Z_O = 50 \Omega$.
 B. C_L includes probe and jig capacitance.

Figure 1. Terminal-to-Bus Test Circuit and Voltage Waveforms

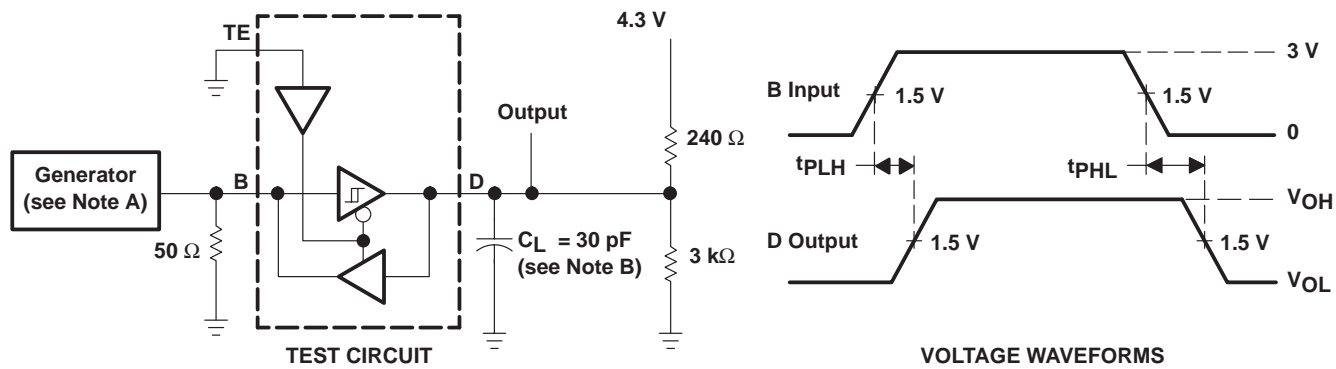

- NOTES: A. The input pulse is supplied by a generator having the following characteristics: $PRR \leq 1 \text{ MHz}$, 50% duty cycle, $t_r \leq 6 \text{ ns}$, $t_f \leq 6 \text{ ns}$, $Z_O = 50 \Omega$.
 B. C_L includes probe and jig capacitance.

Figure 2. Bus-to-Terminal Test Circuit and Voltage Waveforms

PARAMETER MEASUREMENT INFORMATION

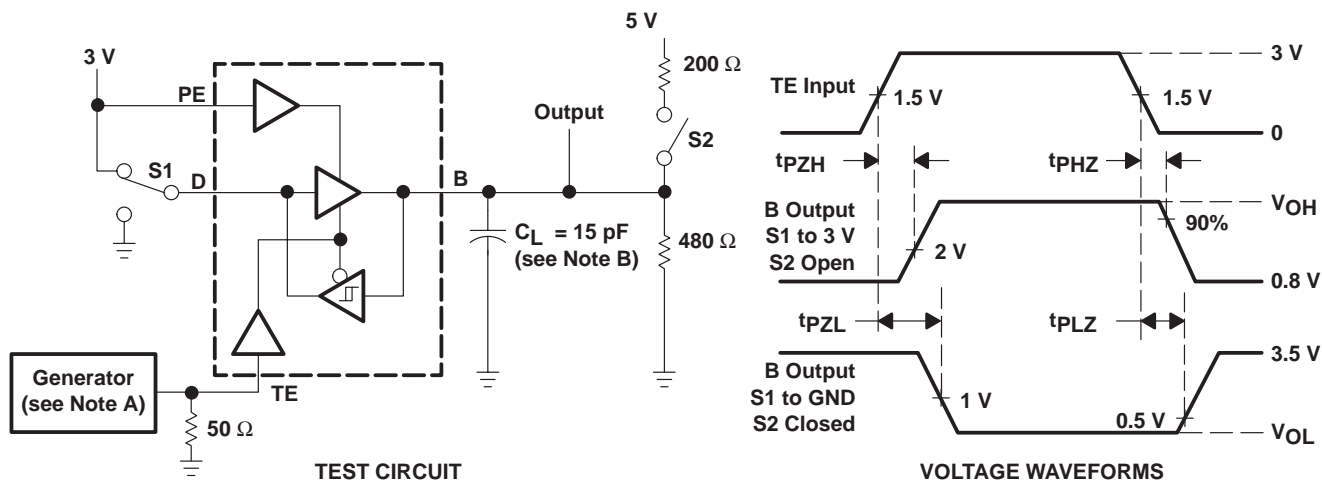

- NOTES: A. The input pulse is supplied by a generator having the following characteristics: PRR \leq 1 MHz, 50% duty cycle, $t_r \leq$ 6 ns, $t_f \leq$ 6 ns, $Z_O = 50 \Omega$.
 B. C_L includes probe and jig capacitance.

Figure 3. TE-to-Bus Test Circuit and Voltage Waveforms

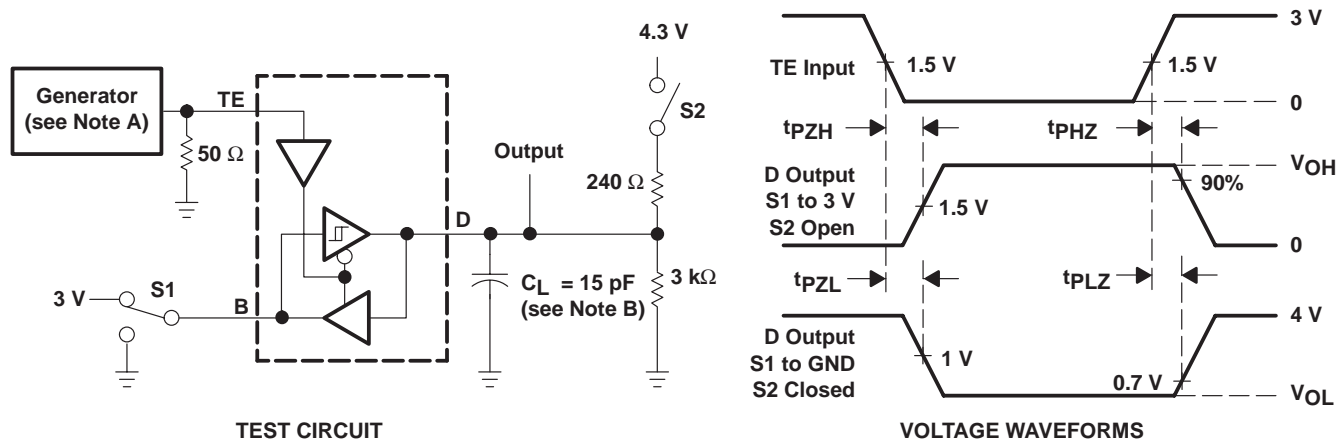

- NOTES: A. The input pulse is supplied by a generator having the following characteristics: PRR \leq 1 MHz, 50% duty cycle, $t_r \leq$ 6 ns, $t_f \leq$ 6 ns, $Z_O = 50 \Omega$.
 B. C_L includes probe and jig capacitance.

Figure 4. TE-to-Terminal Test Circuit and Voltage Waveforms

SN75ALS160 OCTAL GENERAL-PURPOSE INTERFACE BUS TRANSCEIVERS

SLLS018E – JUNE 1986 – REVISED JUNE 2004

PARAMETER MEASUREMENT INFORMATION

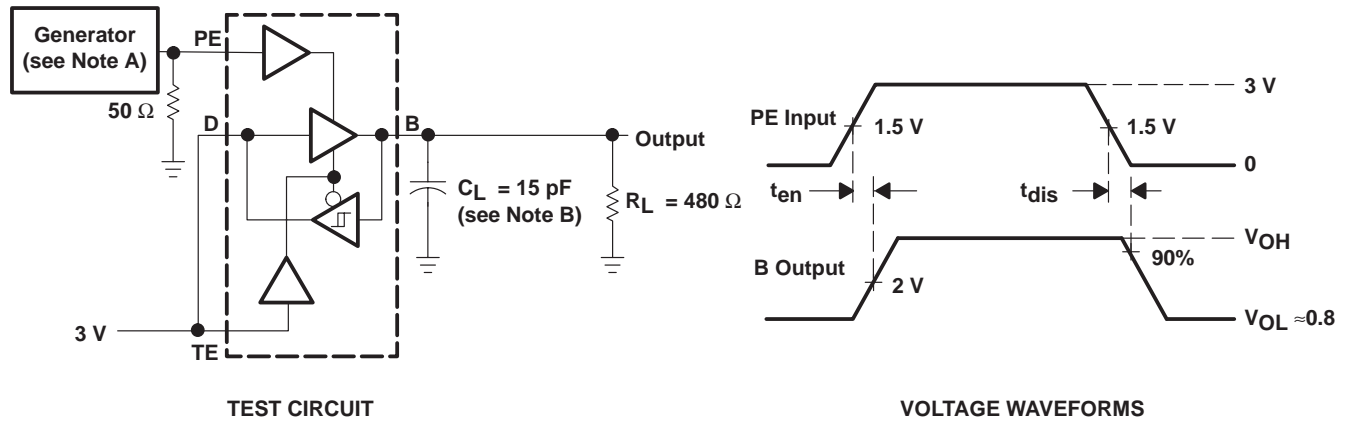

- NOTES: A. The input pulse is supplied by a generator having the following characteristics: $PRR \leq 1 \text{ MHz}$, 50% duty cycle, $t_r \leq 6 \text{ ns}$, $t_f \leq 6 \text{ ns}$, $Z_O = 50 \Omega$.
 B. C_L includes probe and jig capacitance.

Figure 5. PE-to-Bus Test Circuit and Voltage Waveforms

TYPICAL CHARACTERISTICS

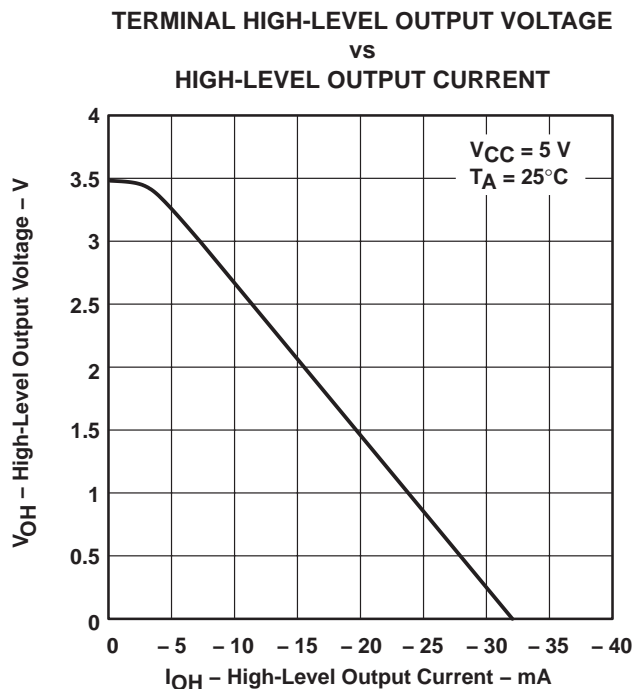

Figure 6

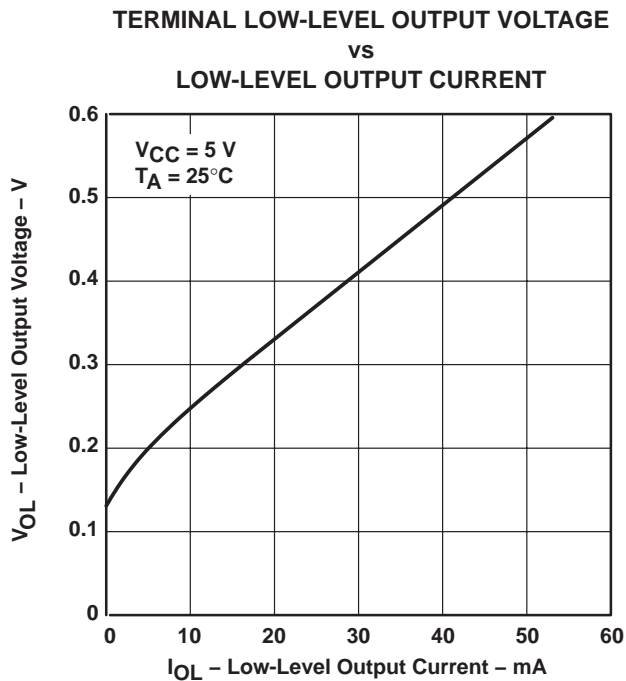

Figure 7

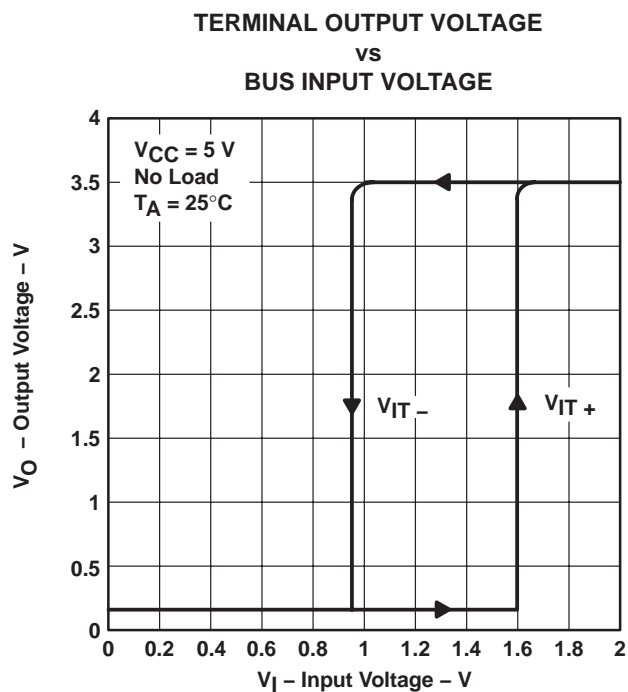
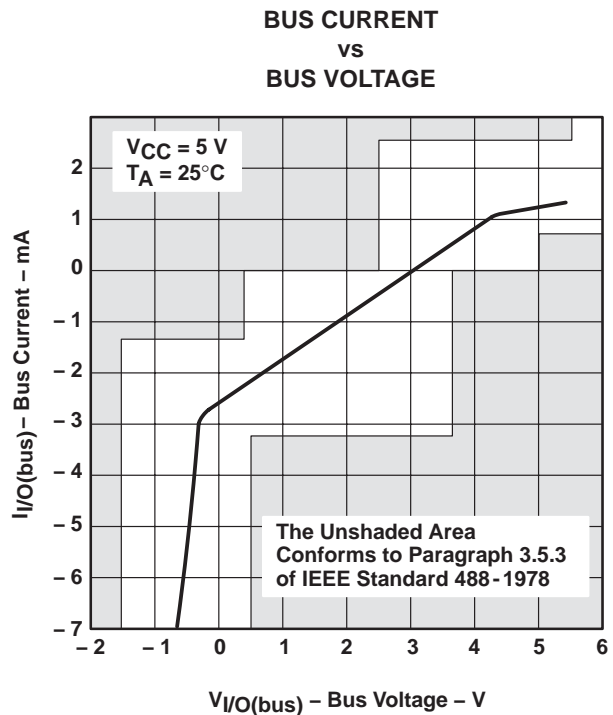
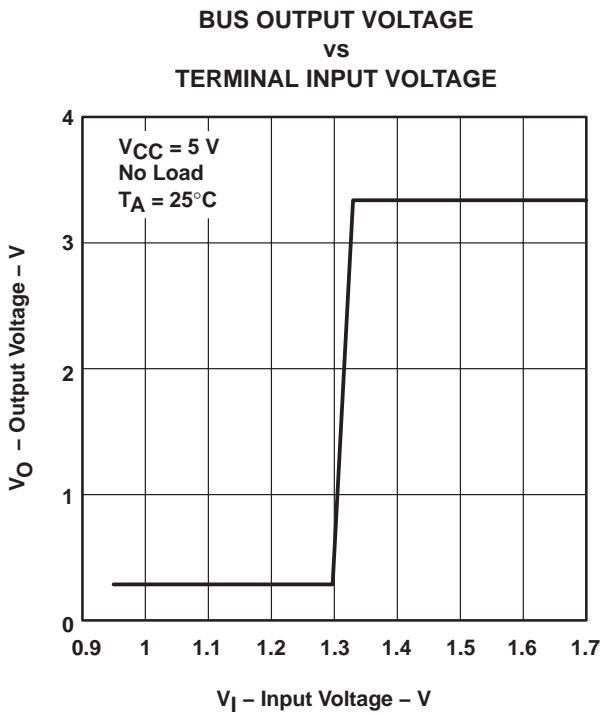
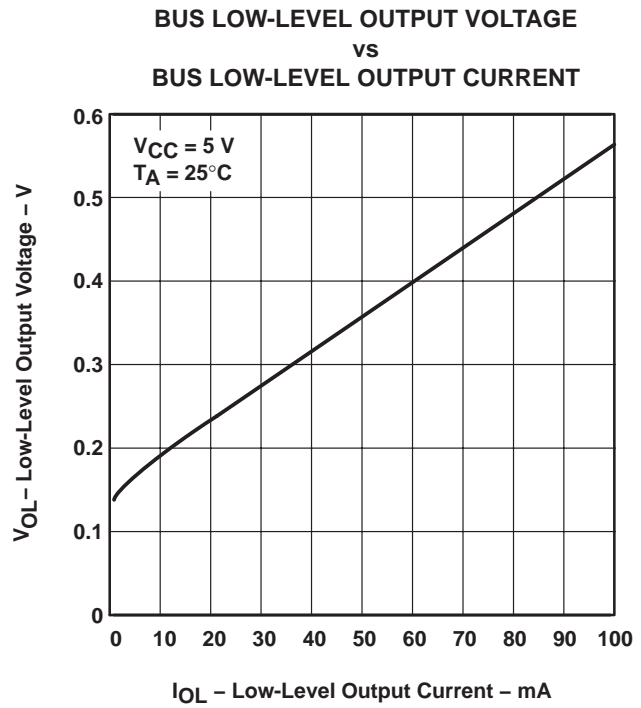
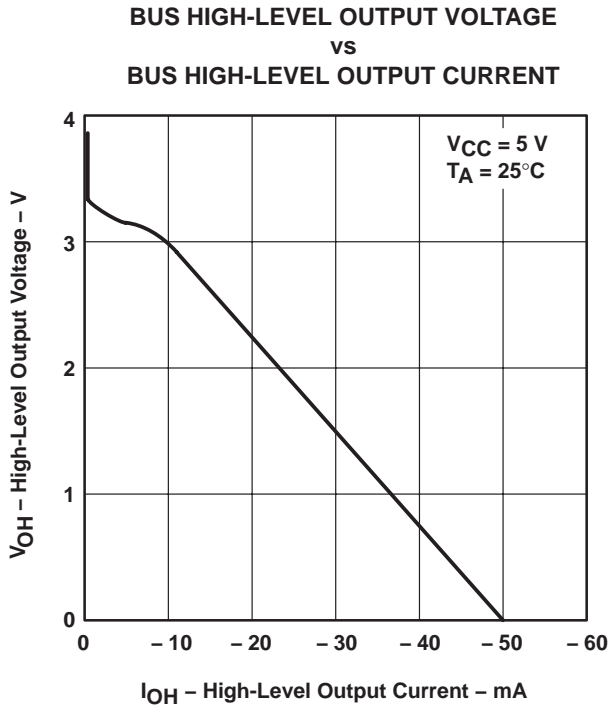

Figure 8

SN75ALS160 OCTAL GENERAL-PURPOSE INTERFACE BUS TRANSCEIVERS

SLLS018E – JUNE 1986 – REVISED JUNE 2004

TYPICAL CHARACTERISTICS



PACKAGING INFORMATION

Orderable Device	Status (1)	Package Type	Package Drawing	Pins	Package Qty	Eco Plan (2)	Lead finish/ Ball material (6)	MSL Peak Temp (3)	Op Temp (°C)	Device Marking (4/5)	Samples
SN75ALS160DW	ACTIVE	SOIC	DW	20	25	RoHS & Green	NIPDAU	Level-1-260C-UNLIM	0 to 70	75ALS160	Samples
SN75ALS160DWE4	ACTIVE	SOIC	DW	20	25	RoHS & Green	NIPDAU	Level-1-260C-UNLIM	0 to 70	75ALS160	Samples
SN75ALS160DWR	ACTIVE	SOIC	DW	20	2000	RoHS & Green	NIPDAU SN	Level-1-260C-UNLIM	0 to 70	75ALS160	Samples
SN75ALS160DWRG4	ACTIVE	SOIC	DW	20	2000	RoHS & Green	NIPDAU	Level-1-260C-UNLIM	0 to 70	75ALS160	Samples
SN75ALS160N	ACTIVE	PDIP	N	20	20	RoHS & Non-Green	NIPDAU	N / A for Pkg Type	0 to 70	SN75ALS160N	Samples

(1) The marketing status values are defined as follows:

ACTIVE: Product device recommended for new designs.

LIFEBUY: TI has announced that the device will be discontinued, and a lifetime-buy period is in effect.

NRND: Not recommended for new designs. Device is in production to support existing customers, but TI does not recommend using this part in a new design.

PREVIEW: Device has been announced but is not in production. Samples may or may not be available.

OBSELETE: TI has discontinued the production of the device.

(2) **RoHS:** TI defines "RoHS" to mean semiconductor products that are compliant with the current EU RoHS requirements for all 10 RoHS substances, including the requirement that RoHS substance do not exceed 0.1% by weight in homogeneous materials. Where designed to be soldered at high temperatures, "RoHS" products are suitable for use in specified lead-free processes. TI may reference these types of products as "Pb-Free".

RoHS Exempt: TI defines "RoHS Exempt" to mean products that contain lead but are compliant with EU RoHS pursuant to a specific EU RoHS exemption.

Green: TI defines "Green" to mean the content of Chlorine (Cl) and Bromine (Br) based flame retardants meet JS709B low halogen requirements of <=1000ppm threshold. Antimony trioxide based flame retardants must also meet the <=1000ppm threshold requirement.

(3) MSL, Peak Temp. - The Moisture Sensitivity Level rating according to the JEDEC industry standard classifications, and peak solder temperature.

(4) There may be additional marking, which relates to the logo, the lot trace code information, or the environmental category on the device.

(5) Multiple Device Markings will be inside parentheses. Only one Device Marking contained in parentheses and separated by a "~" will appear on a device. If a line is indented then it is a continuation of the previous line and the two combined represent the entire Device Marking for that device.

(6) Lead finish/Ball material - Orderable Devices may have multiple material finish options. Finish options are separated by a vertical ruled line. Lead finish/Ball material values may wrap to two lines if the finish value exceeds the maximum column width.

Important Information and Disclaimer: The information provided on this page represents TI's knowledge and belief as of the date that it is provided. TI bases its knowledge and belief on information provided by third parties, and makes no representation or warranty as to the accuracy of such information. Efforts are underway to better integrate information from third parties. TI has taken and continues to take reasonable steps to provide representative and accurate information but may not have conducted destructive testing or chemical analysis on incoming materials and chemicals. TI and TI suppliers consider certain information to be proprietary, and thus CAS numbers and other limited information may not be available for release.

In no event shall TI's liability arising out of such information exceed the total purchase price of the TI part(s) at issue in this document sold by TI to Customer on an annual basis.

OTHER QUALIFIED VERSIONS OF SN75ALS160 :

- Military : [SN55ALS160](#)

NOTE: Qualified Version Definitions:

- Military - QML certified for Military and Defense Applications

TAPE AND REEL INFORMATION

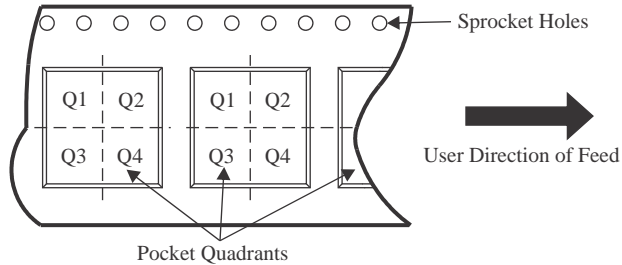
QUADRANT ASSIGNMENTS FOR PIN 1 ORIENTATION IN TAPE

*All dimensions are nominal

Device	Package Type	Package Drawing	Pins	SPQ	Reel Diameter (mm)	Reel Width W1 (mm)	A0 (mm)	B0 (mm)	K0 (mm)	P1 (mm)	W (mm)	Pin1 Quadrant
SN75ALS160DWR	SOIC	DW	20	2000	330.0	24.4	10.8	13.3	2.7	12.0	24.0	Q1
SN75ALS160DWRG4	SOIC	DW	20	2000	330.0	24.4	10.8	13.3	2.7	12.0	24.0	Q1

TAPE AND REEL BOX DIMENSIONS

*All dimensions are nominal

Device	Package Type	Package Drawing	Pins	SPQ	Length (mm)	Width (mm)	Height (mm)
SN75ALS160DWR	SOIC	DW	20	2000	367.0	367.0	45.0
SN75ALS160DWRG4	SOIC	DW	20	2000	367.0	367.0	45.0

TUBE

*All dimensions are nominal

Device	Package Name	Package Type	Pins	SPQ	L (mm)	W (mm)	T (μm)	B (mm)
SN75ALS160DW	DW	SOIC	20	25	507	12.83	5080	6.6
SN75ALS160DW	DW	SOIC	20	25	506.98	12.7	4826	6.6
SN75ALS160DWE4	DW	SOIC	20	25	507	12.83	5080	6.6
SN75ALS160DWE4	DW	SOIC	20	25	506.98	12.7	4826	6.6
SN75ALS160N	N	PDIP	20	20	506	13.97	11230	4.32

N (R-PDIP-T**)

PLASTIC DUAL-IN-LINE PACKAGE

16 PINS SHOWN



4040049/E 12/2002

- NOTES:
- A. All linear dimensions are in inches (millimeters).
 - B. This drawing is subject to change without notice.
 - $\triangle C$ Falls within JEDEC MS-001, except 18 and 20 pin minimum body length (Dim A).
 - $\triangle D$ The 20 pin end lead shoulder width is a vendor option, either half or full width.

DW0020A



PACKAGE OUTLINE

SOIC - 2.65 mm max height

SOIC



4220724/A 05/2016

NOTES:

1. All linear dimensions are in millimeters. Dimensions in parenthesis are for reference only. Dimensioning and tolerancing per ASME Y14.5M.
2. This drawing is subject to change without notice.
3. This dimension does not include mold flash, protrusions, or gate burrs. Mold flash, protrusions, or gate burrs shall not exceed 0.15 mm per side.
4. This dimension does not include interlead flash. Interlead flash shall not exceed 0.43 mm per side.
5. Reference JEDEC registration MS-013.

EXAMPLE BOARD LAYOUT

DW0020A

SOIC - 2.65 mm max height

SOIC



LAND PATTERN EXAMPLE
SCALE:6X

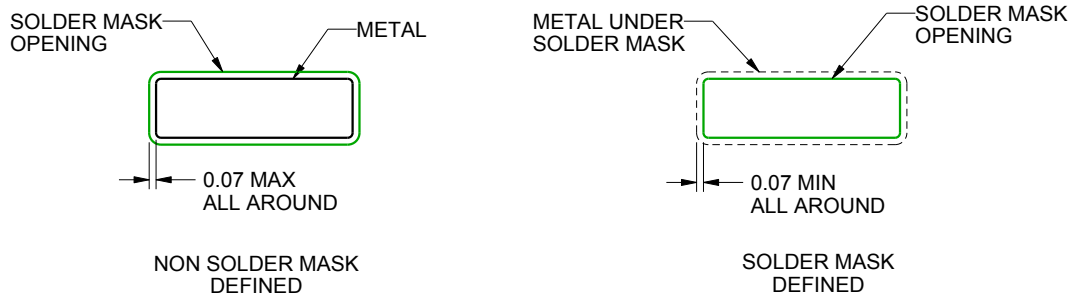

SOLDER MASK DETAILS

4220724/A 05/2016

NOTES: (continued)

- 6. Publication IPC-7351 may have alternate designs.
- 7. Solder mask tolerances between and around signal pads can vary based on board fabrication site.

EXAMPLE STENCIL DESIGN

DW0020A

SOIC - 2.65 mm max height

SOIC



SOLDER PASTE EXAMPLE
BASED ON 0.125 mm THICK STENCIL
SCALE:6X

4220724/A 05/2016

NOTES: (continued)

8. Laser cutting apertures with trapezoidal walls and rounded corners may offer better paste release. IPC-7525 may have alternate design recommendations.
9. Board assembly site may have different recommendations for stencil design.

IMPORTANT NOTICE AND DISCLAIMER

TI PROVIDES TECHNICAL AND RELIABILITY DATA (INCLUDING DATA SHEETS), DESIGN RESOURCES (INCLUDING REFERENCE DESIGNS), APPLICATION OR OTHER DESIGN ADVICE, WEB TOOLS, SAFETY INFORMATION, AND OTHER RESOURCES "AS IS" AND WITH ALL FAULTS, AND DISCLAIMS ALL WARRANTIES, EXPRESS AND IMPLIED, INCLUDING WITHOUT LIMITATION ANY IMPLIED WARRANTIES OF MERCHANTABILITY, FITNESS FOR A PARTICULAR PURPOSE OR NON-INFRINGEMENT OF THIRD PARTY INTELLECTUAL PROPERTY RIGHTS.

These resources are intended for skilled developers designing with TI products. You are solely responsible for (1) selecting the appropriate TI products for your application, (2) designing, validating and testing your application, and (3) ensuring your application meets applicable standards, and any other safety, security, regulatory or other requirements.

These resources are subject to change without notice. TI grants you permission to use these resources only for development of an application that uses the TI products described in the resource. Other reproduction and display of these resources is prohibited. No license is granted to any other TI intellectual property right or to any third party intellectual property right. TI disclaims responsibility for, and you will fully indemnify TI and its representatives against, any claims, damages, costs, losses, and liabilities arising out of your use of these resources.

TI's products are provided subject to [TI's Terms of Sale](#) or other applicable terms available either on [ti.com](https://www.ti.com) or provided in conjunction with such TI products. TI's provision of these resources does not expand or otherwise alter TI's applicable warranties or warranty disclaimers for TI products.

TI objects to and rejects any additional or different terms you may have proposed.

Mailing Address: Texas Instruments, Post Office Box 655303, Dallas, Texas 75265
Copyright © 2024, Texas Instruments Incorporated

Looking for pricing, stock, or lifecycle information?

Click below to explore more details on WIN SOURCE:

 [View SN75ALS160DWG4](#) on WIN SOURCE

 [Texas Instruments](#) Information

Optimize Your Supply Chain with WIN SOURCE Solutions

-  Global Sourcing Solution
-  Obsolete Management
-  Cost Control Management
-  Shortage Management
-  Alternative Solution
-  Excess Inventory Management