



**THE DATASHEET OF
SN74HC165QPWREP**



SN74HC165-EP 8-BIT PARALLEL-LOAD SHIFT REGISTER

SCLS473A – APRIL 2003 – REVISED JANUARY 2004

- **Controlled Baseline**
 - One Assembly/Test Site, One Fabrication Site
- **Extended Temperature Performance of Up To -55°C to 125°C**
- **Enhanced Diminishing Manufacturing Sources (DMS) Support**
- **Enhanced Product-Change Notification**
- **Qualification Pedigree†**
- **2-V to 6-V V_{CC} Operation**
- **Outputs Can Drive Up To 10 LSTTL Loads**
- **Low Power Consumption, $80\text{-}\mu\text{A}$ Max I_{CC}**
- **Typical $t_{pd} = 13\text{ ns}$**
- **$\pm 4\text{-mA}$ Output Drive at 5 V**
- **Low Input Current of $1\ \mu\text{A}$ Max**
- **Complementary Outputs**
- **Direct Overriding Load (Data) Inputs**
- **Gated Clock Inputs**
- **Parallel-to-Serial Data Conversion**

† Component qualification in accordance with JEDEC and industry standards to ensure reliable operation over an extended temperature range. This includes, but is not limited to, Highly Accelerated Stress Test (HAST) or biased 85/85, temperature cycle, autoclave or unbiased HAST, electromigration, bond intermetallic life, and mold compound life. Such qualification testing should not be viewed as justifying use of this component beyond specified performance and environmental limits.

D OR PW PACKAGE
(TOP VIEW)

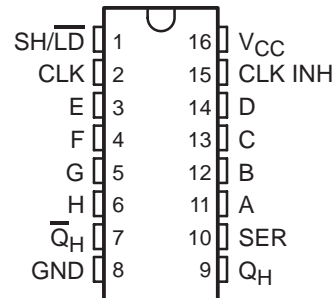

description/ordering information

The SN74HC165 is an 8-bit parallel-load shift register that, when clocked, shifts the data toward a serial (Q_H) output. Parallel-in access to each stage is provided by eight individual direct data (A–H) inputs that are enabled by a low level at the shift/load ($\overline{SH/LD}$) input. The SN74HC165 device also features a clock-inhibit (CLK INH) function and a complementary serial (\overline{Q}_H) output.

Clocking is accomplished by a low-to-high transition of the clock (CLK) input while $\overline{SH/LD}$ is held high and CLK INH is held low. The functions of CLK and CLK INH are interchangeable. Since a low CLK and a low-to-high transition of CLK INH also accomplish clocking, CLK INH should be changed to the high level only while CLK is high. Parallel loading is inhibited when $\overline{SH/LD}$ is held high. While $\overline{SH/LD}$ is low, the parallel inputs to the register are enabled independently of the levels of the CLK, CLK INH, or serial (SER) inputs.

ORDERING INFORMATION

T_A	PACKAGE‡		ORDERABLE PART NUMBER	TOP-SIDE MARKING
-40°C to 125°C	SOIC – D	Tape and reel	SN74HC165QDREP	HC165EP
	TSSOP – PW	Tape and reel	SN74HC165QPWREP	HC165EP
-55°C to 125°C	SOIC – D	Tape and reel	SN74HC165MDREP	HC165MEP

‡ Package drawings, standard packing quantities, thermal data, symbolization, and PCB design guidelines are available at www.ti.com/sc/package.



Please be aware that an important notice concerning availability, standard warranty, and use in critical applications of Texas Instruments semiconductor products and disclaimers thereto appears at the end of this data sheet.

PRODUCTION DATA information is current as of publication date. Products conform to specifications per the terms of Texas Instruments standard warranty. Production processing does not necessarily include testing of all parameters.

 **TEXAS
INSTRUMENTS**

POST OFFICE BOX 655303 • DALLAS, TEXAS 75265

Copyright © 2004, Texas Instruments Incorporated

SN74HC165-EP

8-BIT PARALLEL-LOAD SHIFT REGISTER

SCLS473A – APRIL 2003 – REVISED JANUARY 2004

FUNCTION TABLE

INPUTS			FUNCTION
SH/LD	CLK	CLK INH	
L	X	X	Parallel load
H	H	X	No change
H	X	H	No change
H	L	↑	Shift†
H	↑	L	Shift†

† Shift = content of each internal register shifts toward serial output Q_H. Data at SER is shifted into the first register.

logic diagram (positive logic)

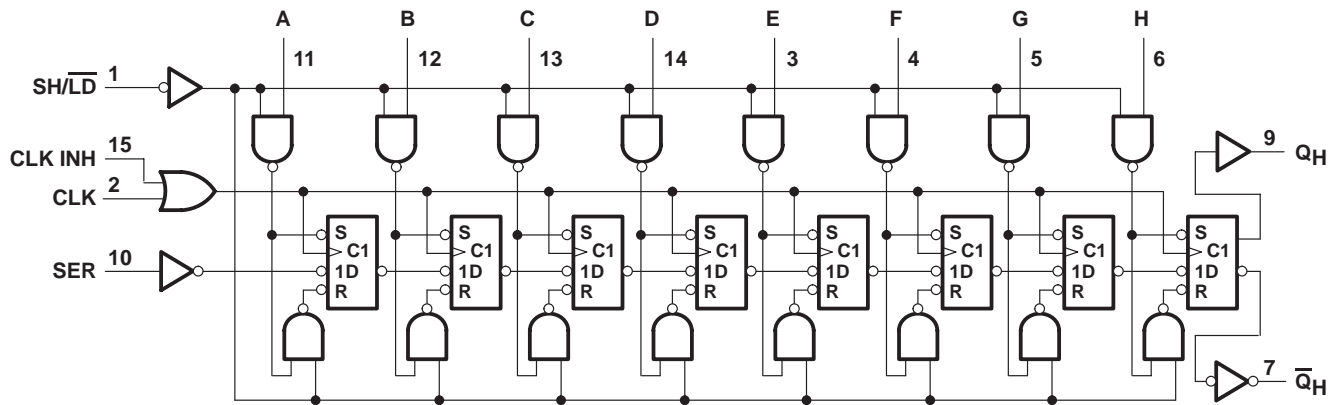

typical shift, load, and inhibit sequence

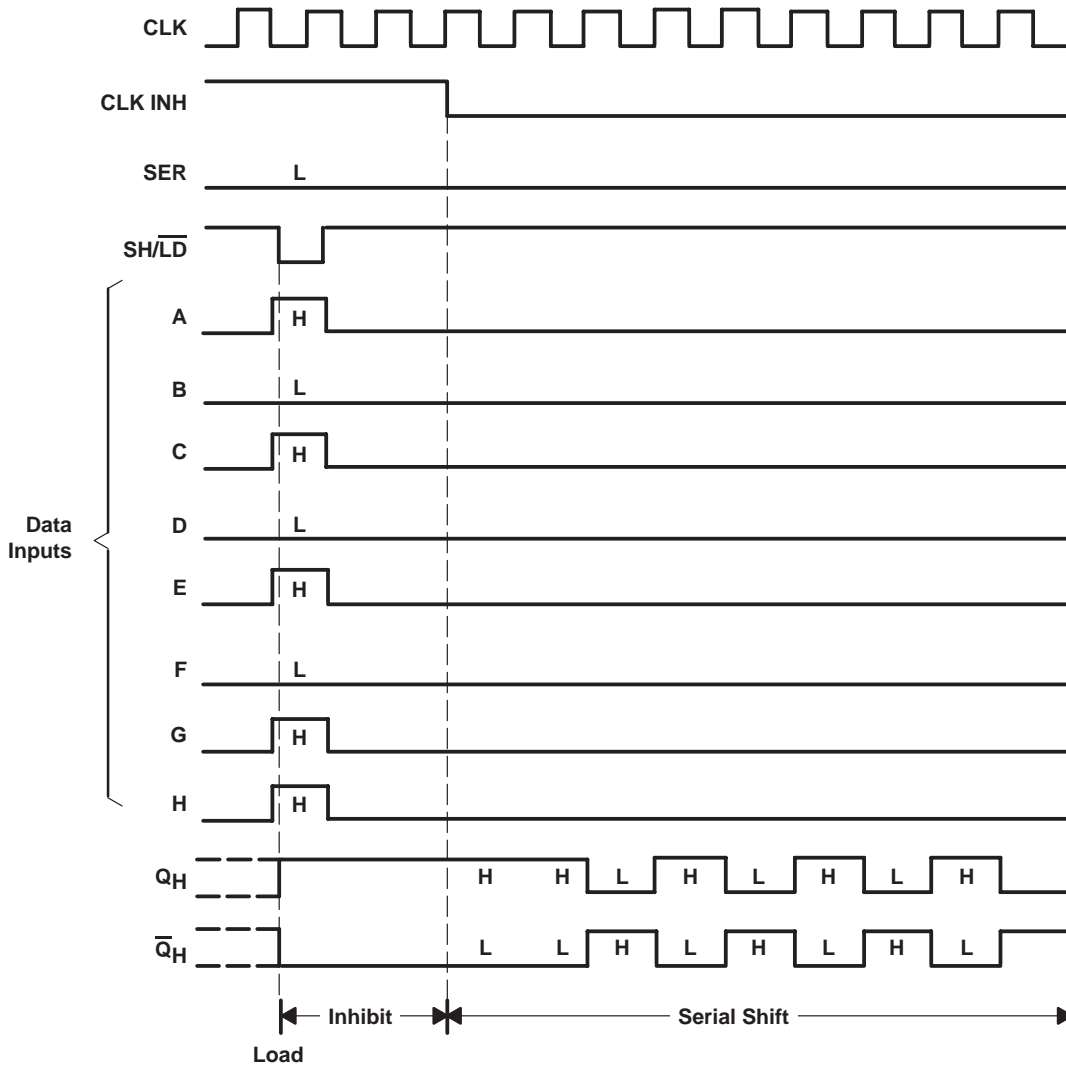

SN74HC165-EP

8-BIT PARALLEL-LOAD SHIFT REGISTER

SCLS473A – APRIL 2003 – REVISED JANUARY 2004

absolute maximum ratings over operating free-air temperature range (unless otherwise noted)[†]

Supply voltage range, V_{CC}	-0.5 V to 7 V
Input clamp current, I_{IK} ($V_I < 0$ or $V_I > V_{CC}$) (see Note 1)	±20 mA
Output clamp current, I_{OK} ($V_O < 0$ or $V_O > V_{CC}$) (see Note 1)	±20 mA
Continuous output current, I_O ($V_O = 0$ to V_{CC})	±25 mA
Continuous current through V_{CC} or GND	±50 mA
Package thermal impedance, θ_{JA} (see Note 2): D package	73°C/W
PW package	108°C/W
Storage temperature range, T_{stg}	-65°C to 150°C

[†] Stresses beyond those listed under “absolute maximum ratings” may cause permanent damage to the device. These are stress ratings only, and functional operation of the device at these or any other conditions beyond those indicated under “recommended operating conditions” is not implied. Exposure to absolute-maximum-rated conditions for extended periods may affect device reliability.

- NOTES: 1. The input and output voltage ratings may be exceeded if the input and output current ratings are observed.
 2. The package thermal impedance is calculated in accordance with JESD 51-7.

recommended operating conditions (see Note 3)

		MIN	NOM	MAX	UNIT
V_{CC}	Supply voltage	2	5	6	V
V_{IH}	High-level input voltage	$V_{CC} = 2$ V	1.5		V
		$V_{CC} = 4.5$ V	3.15		
		$V_{CC} = 6$ V	4.2		
V_{IL}	Low-level input voltage	$V_{CC} = 2$ V		0.5	V
		$V_{CC} = 4.5$ V		1.35	
		$V_{CC} = 6$ V		1.8	
V_I	Input voltage	0		V_{CC}	V
V_O	Output voltage	0		V_{CC}	V
$\Delta t/\Delta v^\ddagger$	Input transition rise/fall time	$V_{CC} = 2$ V		1000	ns
		$V_{CC} = 4.5$ V		500	
		$V_{CC} = 6$ V		400	
T_A	Operating free-air temperature	Q-suffix device	-40	125	°C
		M-suffix device	-55	125	

NOTE 3: All unused inputs of the device must be held at V_{CC} or GND to ensure proper device operation. Refer to the TI application report, *Implications of Slow or Floating CMOS Inputs*, literature number SCBA004.

[‡] If this device is used in the threshold region (from $V_{ILmax} = 0.5$ V to $V_{IHmin} = 1.5$ V), there is a potential to go into the wrong state from induced grounding, causing double clocking. Operating with the inputs at $t_t = 1000$ ns and $V_{CC} = 2$ V does not damage the device; however, functionally, the CLK inputs are not ensured while in the shift, count, or toggle operating modes.



SN74HC165-EP

8-BIT PARALLEL-LOAD SHIFT REGISTER

SCLS473A – APRIL 2003 – REVISED JANUARY 2004

electrical characteristics over recommended operating free-air temperature range (unless otherwise noted)

PARAMETER	TEST CONDITIONS		V _{CC}	T _A = 25°C			MIN	MAX	UNIT
				MIN	TYP	MAX			
V _{OH}	V _I = V _{IH} or V _{IL}	I _{OH} = -20 μA	2 V	1.9	1.998		1.9	V	
			4.5 V	4.4	4.499		4.4		
			6 V	5.9	5.999		5.9		
		I _{OH} = -4 mA	4.5 V	3.98	4.3		3.7		
		I _{OH} = -5.2 mA	6 V	5.48	5.8		5.2		
V _{OL}	V _I = V _{IH} or V _{IL}	I _{OL} = 20 μA	2 V		0.002	0.1		0.1	V
			4.5 V		0.001	0.1		0.1	
			6 V		0.001	0.1		0.1	
		I _{OL} = 4 mA	4.5 V		0.17	0.26		0.4	
		I _{OL} = 5.2 mA	6 V		0.15	0.26		0.4	
I _I	V _I = V _{CC} or 0		6 V		±0.1	±100		±1000	nA
I _{CC}	V _I = V _{CC} or 0, I _O = 0		6 V				8	160	μA
C _i			2 V to 6 V		3	10		10	pF

SN74HC165-EP

8-BIT PARALLEL-LOAD SHIFT REGISTER

SCLS473A – APRIL 2003 – REVISED JANUARY 2004

timing requirements over recommended operating free-air temperature range (unless otherwise noted)

		V _{CC}	T _A = 25°C		MIN	MAX	UNIT
			MIN	MAX			
f _{clock}	Clock frequency	2 V	6		4.2		MHz
		4.5 V	31		21		
		6 V	36		25		
t _w	SH/ $\overline{\text{LD}}$ low	2 V	80		120		ns
		4.5 V	16		24		
		6 V	14		20		
	CLK high or low	2 V	80		120		
		4.5 V	16		24		
		6 V	14		20		
t _{su}	SH/ $\overline{\text{LD}}$ high before CLK \uparrow	2 V	80		120		ns
		4.5 V	16		24		
		6 V	14		20		
	SER before CLK \uparrow	2 V	40		60		
		4.5 V	8		12		
		6 V	7		10		
	CLK INH low before CLK \uparrow	2 V	100		150		
		4.5 V	20		30		
		6 V	17		25		
	CLK INH high before CLK \uparrow	2 V	40		60		
		4.5 V	8		12		
		6 V	7		10		
Data before SH/ $\overline{\text{LD}}$ \downarrow	2 V	100		150			
	4.5 V	20		30			
	6 V	17		26			
t _h	SER data after CLK \uparrow	2 V	5		5		ns
		4.5 V	5		5		
		6 V	5		5		
	PAR data after SH/ $\overline{\text{LD}}$ \downarrow	2 V	5		5		
		4.5 V	5		5		
		6 V	5		5		



SN74HC165-EP 8-BIT PARALLEL-LOAD SHIFT REGISTER

SCLS473A – APRIL 2003 – REVISED JANUARY 2004

switching characteristics over recommended operating free-air temperature range, $C_L = 50$ pF (unless otherwise noted) (see Figure 1)

PARAMETER	FROM (INPUT)	TO (OUTPUT)	V _{CC}	T _A = 25°C			MIN	MAX	UNIT
				MIN	TYP	MAX			
f _{max}			2 V	6	13		4.2	MHz	
			4.5 V	31	50		21		
			6 V	36	62		25		
t _{pd}	SH/ \overline{LD}	Q _H or \overline{Q}_H	2 V		80	150		225	ns
			4.5 V		20	30		45	
			6 V		16	26		38	
	CLK	Q _H or \overline{Q}_H	2 V		75	150		225	
			4.5 V		15	30		45	
			6 V		13	26		38	
	H	Q _H or \overline{Q}_H	2 V		75	150		225	
			4.5 V		15	30		45	
			6 V		13	26		38	
t _t		Any	2 V		38	75		110	ns
			4.5 V		8	15		22	
			6 V		6	13		19	

operating characteristics, T_A = 25°C

PARAMETER	TEST CONDITIONS	TYP	UNIT
C _{pd} Power dissipation capacitance	No load	75	pF

SN74HC165-EP 8-BIT PARALLEL-LOAD SHIFT REGISTER

SCLS473A – APRIL 2003 – REVISED JANUARY 2004

PARAMETER MEASUREMENT INFORMATION

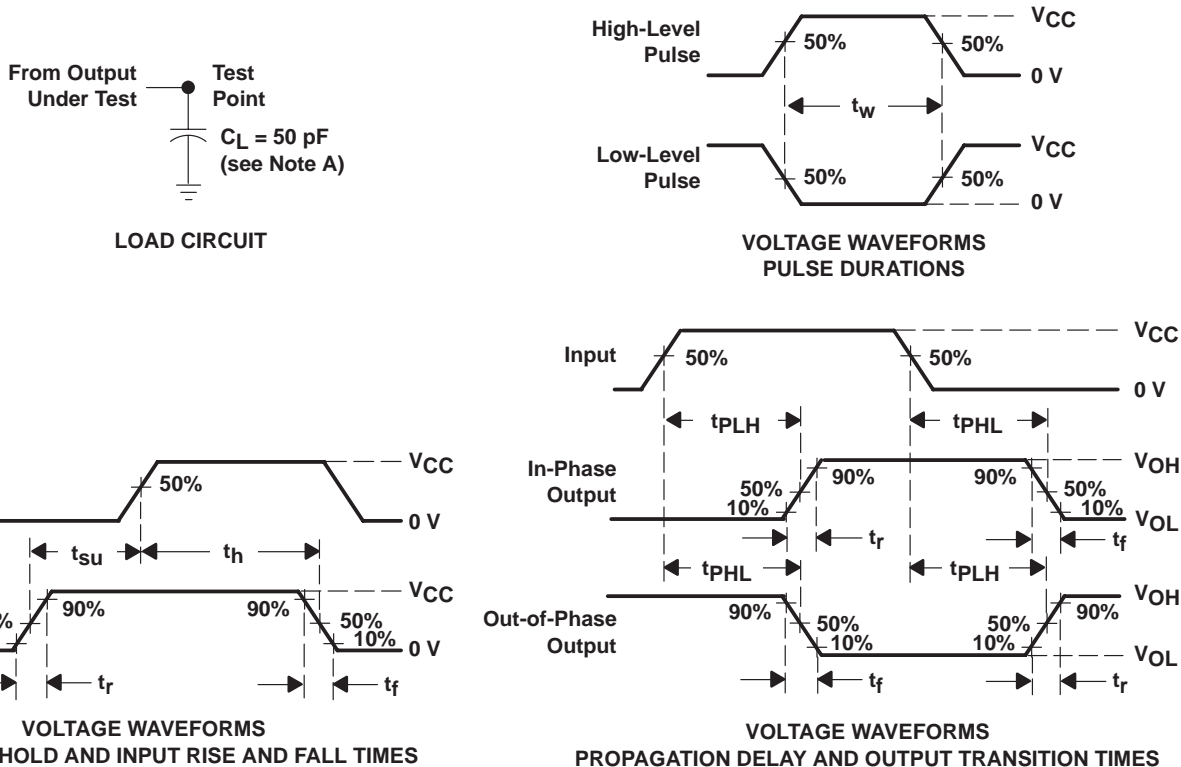

- NOTES:
- A. C_L includes probe and test-fixture capacitance.
 - B. Phase relationships between waveforms were chosen arbitrarily. All input pulses are supplied by generators having the following characteristics: $PRR \leq 1 \text{ MHz}$, $Z_O = 50 \Omega$, $t_r = 6 \text{ ns}$, $t_f = 6 \text{ ns}$.
 - C. For clock inputs, f_{max} is measured when the input duty cycle is 50%.
 - D. The outputs are measured one at a time with one input transition per measurement.
 - E. t_{PLH} and t_{PHL} are the same as t_{pd} .

Figure 1. Load Circuit and Voltage Waveforms

PACKAGING INFORMATION

Orderable Device	Status (1)	Package Type	Package Drawing	Pins	Package Qty	Eco Plan (2)	Lead finish/ Ball material (6)	MSL Peak Temp (3)	Op Temp (°C)	Device Marking (4/5)	Samples
SN74HC165QPWREP	LIFEBUY	TSSOP	PW	16	2000	RoHS & Green	NIPDAU	Level-1-260C-UNLIM	-40 to 125	HC165EP	
V62/04689-01YE	LIFEBUY	TSSOP	PW	16	2000	RoHS & Green	NIPDAU	Level-1-260C-UNLIM	-40 to 125	HC165EP	

(1) The marketing status values are defined as follows:

ACTIVE: Product device recommended for new designs.

LIFEBUY: TI has announced that the device will be discontinued, and a lifetime-buy period is in effect.

NRND: Not recommended for new designs. Device is in production to support existing customers, but TI does not recommend using this part in a new design.

PREVIEW: Device has been announced but is not in production. Samples may or may not be available.

OBSOLETE: TI has discontinued the production of the device.

(2) **RoHS:** TI defines "RoHS" to mean semiconductor products that are compliant with the current EU RoHS requirements for all 10 RoHS substances, including the requirement that RoHS substance do not exceed 0.1% by weight in homogeneous materials. Where designed to be soldered at high temperatures, "RoHS" products are suitable for use in specified lead-free processes. TI may reference these types of products as "Pb-Free".

RoHS Exempt: TI defines "RoHS Exempt" to mean products that contain lead but are compliant with EU RoHS pursuant to a specific EU RoHS exemption.

Green: TI defines "Green" to mean the content of Chlorine (Cl) and Bromine (Br) based flame retardants meet JS709B low halogen requirements of <=1000ppm threshold. Antimony trioxide based flame retardants must also meet the <=1000ppm threshold requirement.

(3) MSL, Peak Temp. - The Moisture Sensitivity Level rating according to the JEDEC industry standard classifications, and peak solder temperature.

(4) There may be additional marking, which relates to the logo, the lot trace code information, or the environmental category on the device.

(5) Multiple Device Markings will be inside parentheses. Only one Device Marking contained in parentheses and separated by a "~" will appear on a device. If a line is indented then it is a continuation of the previous line and the two combined represent the entire Device Marking for that device.

(6) Lead finish/Ball material - Orderable Devices may have multiple material finish options. Finish options are separated by a vertical ruled line. Lead finish/Ball material values may wrap to two lines if the finish value exceeds the maximum column width.

Important Information and Disclaimer:The information provided on this page represents TI's knowledge and belief as of the date that it is provided. TI bases its knowledge and belief on information provided by third parties, and makes no representation or warranty as to the accuracy of such information. Efforts are underway to better integrate information from third parties. TI has taken and continues to take reasonable steps to provide representative and accurate information but may not have conducted destructive testing or chemical analysis on incoming materials and chemicals. TI and TI suppliers consider certain information to be proprietary, and thus CAS numbers and other limited information may not be available for release.

In no event shall TI's liability arising out of such information exceed the total purchase price of the TI part(s) at issue in this document sold by TI to Customer on an annual basis.

OTHER QUALIFIED VERSIONS OF SN74HC165-EP :

- Catalog : [SN74HC165](#)
- Automotive : [SN74HC165-Q1](#)
- Military : [SN54HC165](#)

NOTE: Qualified Version Definitions:

- Catalog - TI's standard catalog product
- Automotive - Q100 devices qualified for high-reliability automotive applications targeting zero defects
- Military - QML certified for Military and Defense Applications

TAPE AND REEL INFORMATION

QUADRANT ASSIGNMENTS FOR PIN 1 ORIENTATION IN TAPE

*All dimensions are nominal

Device	Package Type	Package Drawing	Pins	SPQ	Reel Diameter (mm)	Reel Width W1 (mm)	A0 (mm)	B0 (mm)	K0 (mm)	P1 (mm)	W (mm)	Pin1 Quadrant
SN74HC165QPWREP	TSSOP	PW	16	2000	330.0	12.4	6.9	5.6	1.6	8.0	12.0	Q1

TAPE AND REEL BOX DIMENSIONS



*All dimensions are nominal

Device	Package Type	Package Drawing	Pins	SPQ	Length (mm)	Width (mm)	Height (mm)
SN74HC165QPWREP	TSSOP	PW	16	2000	356.0	356.0	35.0



4220204/A 02/2017

NOTES:

1. All linear dimensions are in millimeters. Any dimensions in parenthesis are for reference only. Dimensioning and tolerancing per ASME Y14.5M.
2. This drawing is subject to change without notice.
3. This dimension does not include mold flash, protrusions, or gate burrs. Mold flash, protrusions, or gate burrs shall not exceed 0.15 mm per side.
4. This dimension does not include interlead flash. Interlead flash shall not exceed 0.25 mm per side.
5. Reference JEDEC registration MO-153.

EXAMPLE BOARD LAYOUT

PW0016A

TSSOP - 1.2 mm max height

SMALL OUTLINE PACKAGE



LAND PATTERN EXAMPLE
EXPOSED METAL SHOWN
SCALE: 10X



SOLDER MASK DETAILS

4220204/A 02/2017

NOTES: (continued)

- 6. Publication IPC-7351 may have alternate designs.
- 7. Solder mask tolerances between and around signal pads can vary based on board fabrication site.

EXAMPLE STENCIL DESIGN

PW0016A

TSSOP - 1.2 mm max height

SMALL OUTLINE PACKAGE



SOLDER PASTE EXAMPLE
BASED ON 0.125 mm THICK STENCIL
SCALE: 10X

4220204/A 02/2017

NOTES: (continued)

8. Laser cutting apertures with trapezoidal walls and rounded corners may offer better paste release. IPC-7525 may have alternate design recommendations.
9. Board assembly site may have different recommendations for stencil design.

IMPORTANT NOTICE AND DISCLAIMER

TI PROVIDES TECHNICAL AND RELIABILITY DATA (INCLUDING DATA SHEETS), DESIGN RESOURCES (INCLUDING REFERENCE DESIGNS), APPLICATION OR OTHER DESIGN ADVICE, WEB TOOLS, SAFETY INFORMATION, AND OTHER RESOURCES "AS IS" AND WITH ALL FAULTS, AND DISCLAIMS ALL WARRANTIES, EXPRESS AND IMPLIED, INCLUDING WITHOUT LIMITATION ANY IMPLIED WARRANTIES OF MERCHANTABILITY, FITNESS FOR A PARTICULAR PURPOSE OR NON-INFRINGEMENT OF THIRD PARTY INTELLECTUAL PROPERTY RIGHTS.

These resources are intended for skilled developers designing with TI products. You are solely responsible for (1) selecting the appropriate TI products for your application, (2) designing, validating and testing your application, and (3) ensuring your application meets applicable standards, and any other safety, security, regulatory or other requirements.

These resources are subject to change without notice. TI grants you permission to use these resources only for development of an application that uses the TI products described in the resource. Other reproduction and display of these resources is prohibited. No license is granted to any other TI intellectual property right or to any third party intellectual property right. TI disclaims responsibility for, and you will fully indemnify TI and its representatives against, any claims, damages, costs, losses, and liabilities arising out of your use of these resources.

TI's products are provided subject to [TI's Terms of Sale](#) or other applicable terms available either on [ti.com](https://www.ti.com) or provided in conjunction with such TI products. TI's provision of these resources does not expand or otherwise alter TI's applicable warranties or warranty disclaimers for TI products.

TI objects to and rejects any additional or different terms you may have proposed.

Mailing Address: Texas Instruments, Post Office Box 655303, Dallas, Texas 75265
Copyright © 2023, Texas Instruments Incorporated

Looking for pricing, stock, or lifecycle information?

Click below to explore more details on WIN SOURCE:

 [View SN74HC165QPWREP on WIN SOURCE](#)

 [Texas Instruments](#) Information

Optimize Your Supply Chain with WIN SOURCE Solutions

-  Global Sourcing Solution
-  Obsolete Management
-  Cost Control Management
-  Shortage Management
-  Alternative Solution
-  Excess Inventory Management