



**THE DATASHEET OF  
SN74HC109NSR**



# SNx4HC109 Dual J-K Positive-Edge-Triggered Flip-Flops With Clear and Preset

## 1 Features

- Wide operating voltage range of 2 V to 6 V
- Low input current of 1  $\mu$ A max
- High-current outputs drive up to 10 LSTTL loads
- Low power consumption, 40- $\mu$ A max  $I_{CC}$
- Typical  $t_{pd} = 12$  ns
- $\pm 4$ -mA output drive at 5 V

## 2 Description

These devices contain two independent J-K positive-edge-triggered flip-flops. A low level at the preset ( $\overline{PRE}$ ) or clear ( $\overline{CLR}$ ) inputs sets or resets the outputs, regardless of the levels of the other inputs. When  $\overline{PRE}$  and  $\overline{CLR}$  are inactive (high), data at the J and  $\overline{K}$  inputs meeting the setup-time requirements are transferred to the outputs on the positive-going edge of the clock (CLK) pulse. Clock triggering occurs at a voltage level and is not related directly to the rise time of the clock pulse. Following the hold-time interval, data at the J and  $\overline{K}$  inputs can be changed without affecting the levels at the outputs. These versatile flip-flops can perform as toggle flip-flops by grounding  $\overline{K}$  and tying J high. They also can perform as D-type flip-flops if J and  $\overline{K}$  are tied together.

### Device Information

PART NUMBER	PACKAGE <sup>(1)</sup>	BODY SIZE (NOM)
SN54HC109J	CDIP (16)	24.38 mm $\times$ 6.92 mm
SN74HC109D	SOIC (16)	9.90 mm $\times$ 3.90 mm
SN74HC109N	PDIP (16)	19.31 mm $\times$ 6.35 mm
SN74HC109NS	SO (16)	6.20 mm $\times$ 5.30 mm
SNJ54HC109FK	LCCC (20)	8.89 mm $\times$ 8.45 mm
SNJ54HC109W	CFP (16)	10.16 mm $\times$ 6.73 mm

(1) For all available packages, see the orderable addendum at the end of the data sheet.

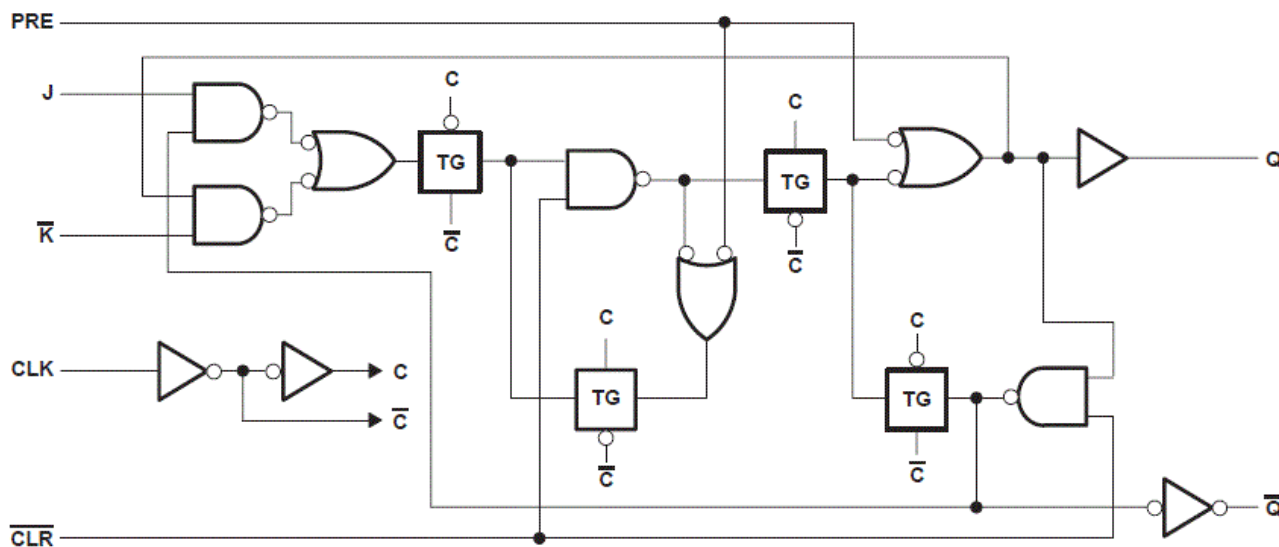

Functional Block Diagram



## Table of Contents

<b>1 Features</b> .....	1	7.1 Overview.....	8
<b>2 Description</b> .....	1	7.2 Functional Block Diagram.....	8
<b>3 Revision History</b> .....	2	7.3 Device Functional Modes.....	8
<b>4 Pin Configuration and Functions</b> .....	3	<b>8 Power Supply Recommendations</b> .....	9
<b>5 Specifications</b> .....	4	<b>9 Layout</b> .....	9
5.1 Absolute Maximum Ratings.....	4	9.1 Layout Guidelines.....	9
5.2 Recommended Operating Conditions <sup>(1)</sup> .....	4	<b>10 Device and Documentation Support</b> .....	10
5.3 Thermal Information.....	4	10.1 Receiving Notification of Documentation Updates..	10
5.4 Electrical Characteristics.....	5	10.2 Support Resources.....	10
5.5 Timing Requirements.....	5	10.3 Trademarks.....	10
5.6 Switching Characteristics .....	6	10.4 Electrostatic Discharge Caution.....	10
5.7 Operating Characteristics.....	6	10.5 Glossary.....	10
<b>6 Parameter Measurement Information</b> .....	7	<b>11 Mechanical, Packaging, and Orderable Information</b> .....	10
<b>7 Detailed Description</b> .....	8		

### 3 Revision History

NOTE: Page numbers for previous revisions may differ from page numbers in the current version.

<b>Changes from Revision B (February 2022) to Revision C (June 2022)</b>	<b>Page</b>
• Junction-to-ambient thermal resistance values increased. D was 73 is now 117.2, N was 67 is now 60.5, NS was 64 is now 88.3.....	4

---

<b>Changes from Revision A (October 2003) to Revision B (February 2022)</b>	<b>Page</b>
• Updated the numbering, formatting, tables, figures, and cross-references throughout the document to reflect modern data sheet standards.....	1

## 4 Pin Configuration and Functions

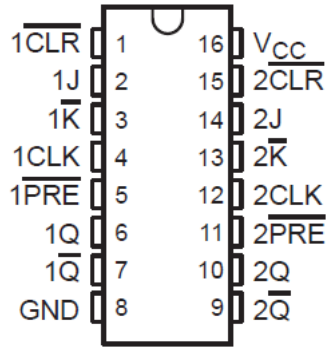

**J, W, D, N, or NS Package**  
**16-Pin CDIP, CFP, SOIC, PDIP, or SO**  
**Top View**

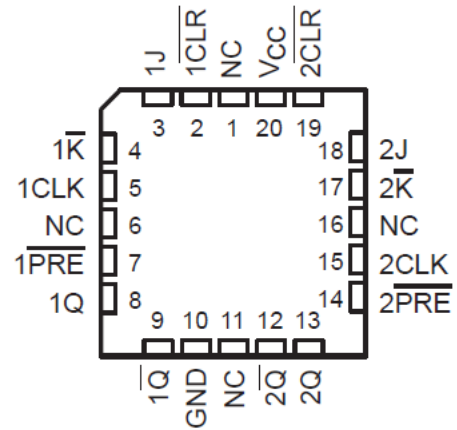

NC - No internal connection

**FK Package**  
**20-Pin LCCC**  
**Top View**

## 5 Specifications

### 5.1 Absolute Maximum Ratings

over operating free-air temperature range (unless otherwise noted)<sup>(1)</sup>

			MIN	MAX	UNIT
V <sub>CC</sub>	Supply voltage range		-0.5	7	V
I <sub>IK</sub>	Input clamp current	V <sub>I</sub> < 0 or V <sub>I</sub> > V <sub>CC</sub>		±20	mA
I <sub>OK</sub>	Output clamp current	V <sub>O</sub> < 0 or V <sub>O</sub> > V <sub>CC</sub>		±20	mA
I <sub>O</sub>	Continuous output current	V <sub>O</sub> = 0 to V <sub>CC</sub>		±35	mA
	Continuous current through V <sub>CC</sub> or GND			±70	mA
	Lead temperature 1,6 mm (1/16 inch) from case for 60 seconds	FK package		300	°C
		J package			
		W package			
	Lead temperature 1,6 mm (1/16 inch) from case for 10 seconds	D package		260	°C
		N package			
		NS package			
T <sub>J</sub>	Junction temperature			150	°C
T <sub>stg</sub>	Storage temperature range		-65	150	°C

(1) Stresses beyond those listed under "absolute maximum ratings" may cause permanent damage to the device. These are stress ratings only, and functional operation of the device at these or any other conditions beyond those indicated under "recommended operating conditions" is not implied. Exposure to absolute-maximum-rated conditions for extended periods may affect device reliability.

### 5.2 Recommended Operating Conditions<sup>(1)</sup>

			SN54HC109			SN74HC109			UNIT
			MIN	NOM	MAX	MIN	NOM	MAX	
V <sub>CC</sub>	Supply voltage		2	5	6	2	5	6	V
V <sub>IH</sub>	High-level input voltage	V <sub>CC</sub> = 2 V	1.5			1.5			V
		V <sub>CC</sub> = 4.5 V	3.15			3.15			
		V <sub>CC</sub> = 6 V	4.2			4.2			
V <sub>IL</sub>	Low-level input voltage	V <sub>CC</sub> = 2 V	0.3			0.5			V
		V <sub>CC</sub> = 4.5 V	0.9			1.35			
		V <sub>CC</sub> = 6 V	1.2			1.8			
V <sub>I</sub>	Input voltage		0	V <sub>CC</sub>		0	V <sub>CC</sub>		V
V <sub>O</sub>	Output voltage		0	V <sub>CC</sub>		0	V <sub>CC</sub>		V
Δt/Δv	Input transition rise/fall time	V <sub>CC</sub> = 2 V	1000			1000			ns
		V <sub>CC</sub> = 4.5 V	500			500			
		V <sub>CC</sub> = 6 V	400			400			
T <sub>A</sub>	Operating free-air temperature		-55	125		-40	85		°C

(1) All unused inputs of the device must be held at V<sub>CC</sub> or GND to ensure proper device operation. Refer to the TI application report, *Implications of Slow or Floating CMOS Inputs*, literature number [SCBA004](#).

### 5.3 Thermal Information

THERMAL METRIC		D (SOIC)	N (PDIP)	NS (SO)	UNIT
		16 PINS	16 PINS	16 PINS	
R <sub>θJA</sub>	Junction-to-ambient thermal resistance <sup>(1)</sup>	117.2	60.5	88.3	°C/W
R <sub>θJC(top)</sub>	Junction-to-case (top) thermal resistance	77.2	47.9	45.9	°C/W
R <sub>θJB</sub>	Junction-to-board thermal resistance	75.6	40.4	50.9	°C/W

### 5.3 Thermal Information (continued)

THERMAL METRIC		D (SOIC)	N (PDIP)	NS (SO)	UNIT
		16 PINS	16 PINS	16 PINS	
$\Psi_{JT}$	Junction-to-top characterization parameter	38.1	27.3	12.9	°C/W
$\Psi_{JB}$	Junction-to-board characterization parameter	75.3	40.2	50.1	°C/W
$R_{\theta JC(bot)}$	Junction-to-case (bottom) thermal resistance	N/A	N/A	N/A	°C/W

- (1) For more information about traditional and new thermal metrics, see the [Semiconductor and IC package thermal metrics](#) application report.

### 5.4 Electrical Characteristics

over recommended operating free-air temperature range (unless otherwise noted)

PARAMETER	TEST CONDITIONS		$V_{CC}$	$T_A = 25^\circ\text{C}$			SN54HC109		SN74HC109		UNIT	
				MIN	TYP	MAX	MIN	MAX	MIN	MAX		
$V_{OH}$	$V_I = V_{IH}$ or $V_{IL}$	$I_{OH} = -20 \mu\text{A}$	2 V	1.9	1.998		1.9		1.9	V		
			4.5 V	4.4	4.499		4.4		4.4			
			6 V	5.9	5.999		5.9		5.9			
		$I_{OH} = -4 \text{ mA}$	4.5 V	3.98	4.3		3.7		3.84			
		$I_{OH} = -5.2 \text{ mA}$	6 V	5.48	5.8		5.2		5.34			
$V_{OL}$	$V_I = V_{IH}$ or $V_{IL}$	$I_{OL} = 20 \mu\text{A}$	2 V		0.002	0.1		0.1		0.1	V	
			4.5 V		0.001	0.1		0.1		0.1		
			6 V		0.001	0.1		0.1		0.1		
		$I_{OL} = 4 \text{ mA}$	4.5 V		0.17	0.26		0.4		0.33		
		$I_{OL} = 5.2 \text{ mA}$	6 V		0.15	0.26		0.4		0.33		
$I_I$	$V_I = V_{CC}$ or 0		6 V		$\pm 0.1$	$\pm 100$		$\pm 1000$		$\pm 1000$	nA	
$I_{CC}$	$V_I = V_{CC}$ or 0, $I_O = 0$		6 V					4		80	40	$\mu\text{A}$
$C_i$			2 V to 6 V		3	10		10		10	pF	

### 5.5 Timing Requirements

over recommended operating free-air temperature range (unless otherwise noted)

		$V_{CC}$	$T_A = 25^\circ\text{C}$		SN54HC109		SN74HC109		UNIT
			MIN	MAX	MIN	MAX	MIN	MAX	
$f_{\text{clock}}$	Clock frequency	2 V		6		4.2		5	MHz
		4.5 V		31		21		25	
		6 V		36		25		29	
$t_w$	Pulse duration	PRE or $\overline{\text{CLR}}$ low	2 V	100		150		125	ns
			4.5 V	20		30		25	
			6 V	17		25		21	
		CLK high or low	2 V	80		120		100	
			4.5 V	16		24		20	
			6 V	14		20		17	

over recommended operating free-air temperature range (unless otherwise noted)

	$V_{CC}$	$T_A = 25^\circ\text{C}$		SN54HC109		SN74HC109		UNIT
		MIN	MAX	MIN	MAX	MIN	MAX	
$t_{su}$	Setup time before CLK $\uparrow$	Data (J, $\bar{K}$ )	2 V	100	150	125	ns	
			4.5 V	20	30	25		
			6 V	17	25	21		
		$\overline{PRE}$ or $\overline{CLR}$ inactive	2 V	25	40	30		
			4.5 V	5	8	6		
			6 V	4	7	5		
$t_h$	Hold time	Data after CLK $\uparrow$	2 V	0	0	0	ns	
			4.5 V	0	0	0		
			6 V	0	0	0		

### 5.6 Switching Characteristics

over recommended operating free-air temperature range,  $C_L = 50$  pF (unless otherwise noted) (see [Figure 6-1](#))

PARAMETER	FROM (INPUT)	TO (OUTPUT)	$V_{CC}$	$T_A = 25^\circ\text{C}$			SN54HC109		SN74HC109		UNIT
				MIN	TYP	MAX	MIN	MAX	MIN	MAX	
$f_{max}$			2 V	6	10		4.2	5	ns		
			4.5 V	31	50		21	25			
			6 V	36	60		25	29			
$t_{pd}$	$\overline{PRE}$ or $\overline{CLR}$	Q or $\bar{Q}$	2 V		60	230		345	290	ns	
			4.5 V		15	46		69	58		
			6 V		12	39		59	49		
	CLK	Q or $\bar{Q}$	2 V		50	175		250	220		
			4.5 V		15	35		50	44		
			6 V		12	30		42	37		
$t_t$		Q or $\bar{Q}$	2 V		28	75		110	95	ns	
			4.5 V		8	15		22	19		
			6 V		6	13		19	16		

### 5.7 Operating Characteristics

$T_A = 25^\circ\text{C}$

PARAMETER	TEST CONDITIONS	TYP	UNIT
$C_{pd}$	Power dissipation capacitance per buffer/driver	No load	35 pF

## 6 Parameter Measurement Information

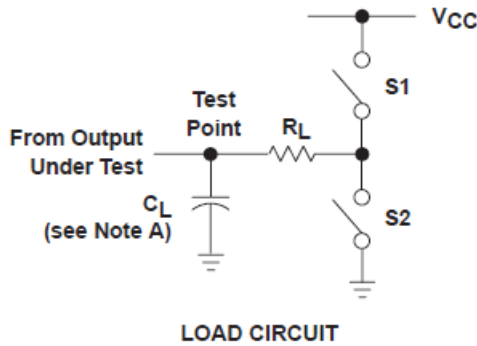

PARAMETER		R <sub>L</sub>	C <sub>L</sub>	S1	S2
t <sub>en</sub>	t <sub>PZH</sub>	1 kΩ	50 pF or 150 pF	Open	Closed
	t <sub>PZL</sub>			Closed	Open
t <sub>dis</sub>	t <sub>PHZ</sub>	1 kΩ	50 pF	Open	Closed
	t <sub>PLZ</sub>			Closed	Open
t <sub>pd</sub> or t <sub>t</sub>		--	50 pF or 150 pF	Open	Open

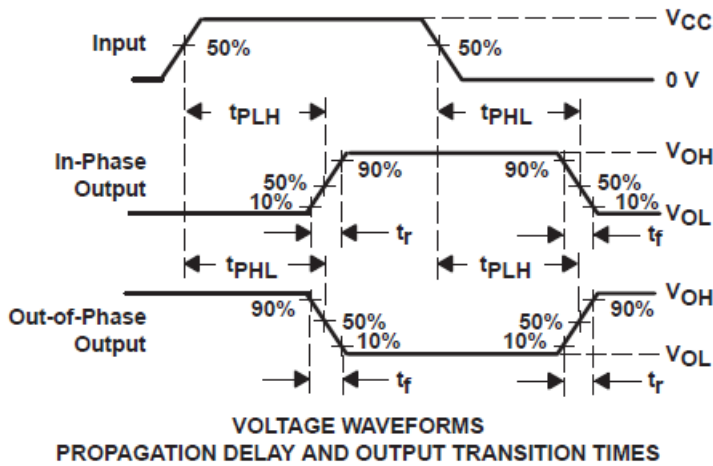

VOLTAGE WAVEFORMS  
PROPAGATION DELAY AND OUTPUT TRANSITION TIMES

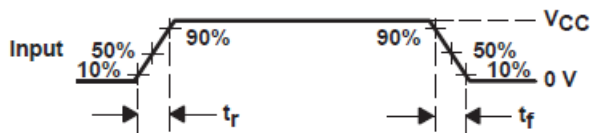

VOLTAGE WAVEFORM  
INPUT RISE AND FALL TIMES

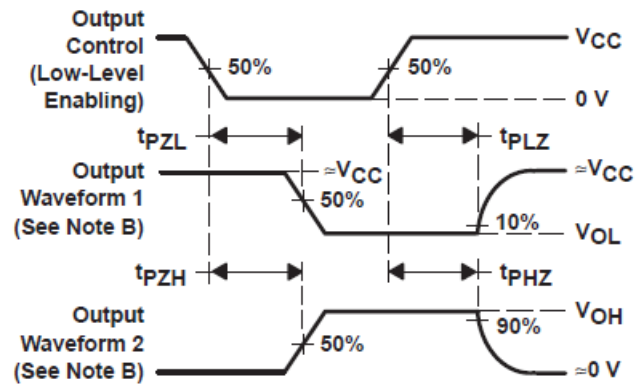

VOLTAGE WAVEFORMS  
ENABLE AND DISABLE TIMES FOR 3-STATE OUTPUTS

- C<sub>L</sub> includes probe and test-fixture capacitance.
- Waveform 1 is for an output with internal conditions such that the output is low except when disabled by the output control. Waveform 2 is for an output with internal conditions such that the output is high except when disabled by the output control.
- Phase relationships between waveforms were chosen arbitrarily. All input pulses are supplied by generators having the following characteristics: PRR ≤ 1 MHz, Z<sub>O</sub> = 50 Ω, t<sub>r</sub> = 6 ns, t<sub>f</sub> = 6 ns.
- The outputs are measured one at a time with one input transition per measurement.
- t<sub>PLZ</sub> and t<sub>PHZ</sub> are the same as t<sub>dis</sub>.
- t<sub>PZL</sub> and t<sub>PZH</sub> are the same as t<sub>en</sub>.
- t<sub>PLH</sub> and t<sub>PHL</sub> are the same as t<sub>pd</sub>.

Figure 6-1. Load Circuit and Voltage Waveforms

## 7 Detailed Description

### 7.1 Overview

These devices contain two independent J-K positive-edge-triggered flip-flops. A low level at the preset ( $\overline{\text{PRE}}$ ) or clear ( $\overline{\text{CLR}}$ ) inputs sets or resets the outputs, regardless of the levels of the other inputs. When  $\overline{\text{PRE}}$  and  $\overline{\text{CLR}}$  are inactive (high), data at the J and  $\overline{\text{K}}$  inputs meeting the setup-time requirements are transferred to the outputs on the positive-going edge of the clock (CLK) pulse. Clock triggering occurs at a voltage level and is not related directly to the rise time of the clock pulse. Following the hold-time interval, data at the J and  $\overline{\text{K}}$  inputs can be changed without affecting the levels at the outputs. These versatile flip-flops can perform as toggle flip-flops by grounding  $\overline{\text{K}}$  and tying J high. They also can perform as D-type flip-flops if J and  $\overline{\text{K}}$  are tied together.

### 7.2 Functional Block Diagram

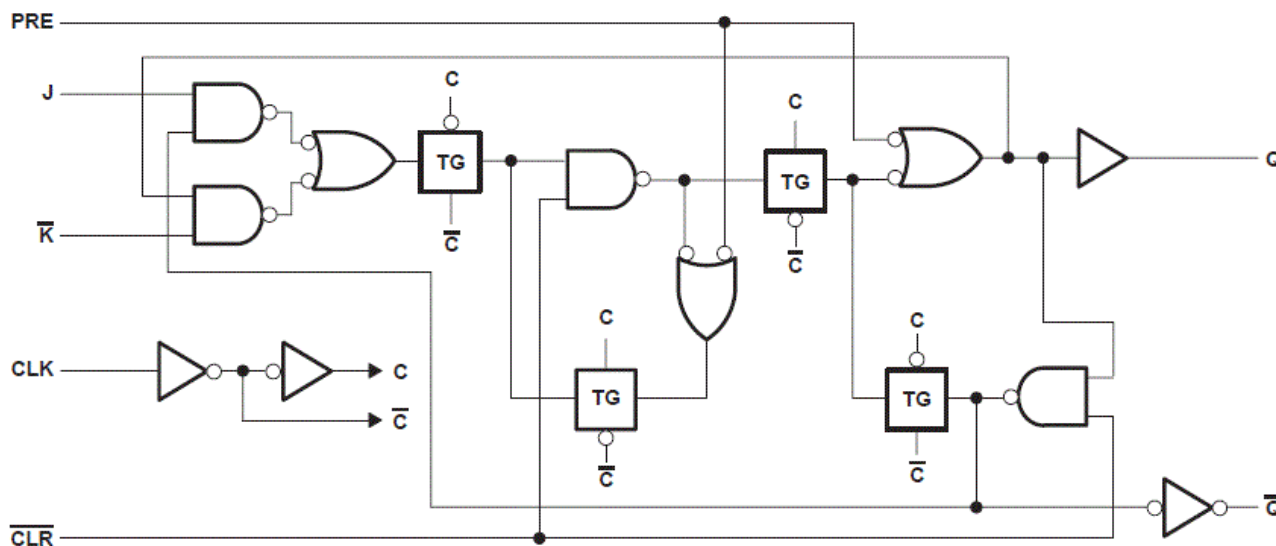

### 7.3 Device Functional Modes

Table 7-1. Function Table

INPUTS					OUTPUTS	
PRE	$\overline{\text{CLR}}$	CLK	J	$\overline{\text{K}}$	Q	$\overline{\text{Q}}$
L	H	X	X	X	H	L
H	L	X	X	X	L	H
L	L	X	X	X	H <sup>(1)</sup>	H <sup>(1)</sup>
H	H	↑	L	L	L	H
H	H	↑	H	L	Toggle	
H	H	↑	L	H	Q0	$\overline{\text{Q0}}$
H	H	↑	H	H	H	L
H	H	L	X	X	Q0	$\overline{\text{Q0}}$

(1) This configuration is nonstable; that is, it does not persist when either  $\overline{\text{PRE}}$  or  $\overline{\text{CLR}}$  returns to its inactive (high) level.

## 8 Power Supply Recommendations

The power supply can be any voltage between the minimum and maximum supply voltage rating located in the *Recommended Operating Conditions*. Each  $V_{CC}$  terminal should have a good bypass capacitor to prevent power disturbance. A 0.1- $\mu\text{F}$  capacitor is recommended for this device. It is acceptable to parallel multiple bypass caps to reject different frequencies of noise. The 0.1- $\mu\text{F}$  and 1- $\mu\text{F}$  capacitors are commonly used in parallel. The bypass capacitor should be installed as close to the power terminal as possible for best results.

## 9 Layout

### 9.1 Layout Guidelines

When using multiple-input and multiple-channel logic devices inputs must not ever be left floating. In many cases, functions or parts of functions of digital logic devices are unused; for example, when only two inputs of a triple-input AND gate are used or only 3 of the 4 buffer gates are used. Such unused input pins must not be left unconnected because the undefined voltages at the outside connections result in undefined operational states. All unused inputs of digital logic devices must be connected to a logic high or logic low voltage, as defined by the input voltage specifications, to prevent them from floating. The logic level that must be applied to any particular unused input depends on the function of the device. Generally, the inputs are tied to GND or  $V_{CC}$ , whichever makes more sense for the logic function or is more convenient.

## 10 Device and Documentation Support

TI offers an extensive line of development tools. Tools and software to evaluate the performance of the device, generate code, and develop solutions are listed below.

### 10.1 Receiving Notification of Documentation Updates

To receive notification of documentation updates, navigate to the device product folder on [ti.com](http://ti.com). Click on *Subscribe to updates* to register and receive a weekly digest of any product information that has changed. For change details, review the revision history included in any revised document.

### 10.2 Support Resources

TI E2E™ [support forums](#) are an engineer's go-to source for fast, verified answers and design help — straight from the experts. Search existing answers or ask your own question to get the quick design help you need.

Linked content is provided "AS IS" by the respective contributors. They do not constitute TI specifications and do not necessarily reflect TI's views; see TI's [Terms of Use](#).

### 10.3 Trademarks

TI E2E™ is a trademark of Texas Instruments.

All trademarks are the property of their respective owners.

### 10.4 Electrostatic Discharge Caution



This integrated circuit can be damaged by ESD. Texas Instruments recommends that all integrated circuits be handled with appropriate precautions. Failure to observe proper handling and installation procedures can cause damage.

ESD damage can range from subtle performance degradation to complete device failure. Precision integrated circuits may be more susceptible to damage because very small parametric changes could cause the device not to meet its published specifications.

### 10.5 Glossary

[TI Glossary](#) This glossary lists and explains terms, acronyms, and definitions.

## 11 Mechanical, Packaging, and Orderable Information

The following pages include mechanical, packaging, and orderable information. This information is the most current data available for the designated devices. This data is subject to change without notice and revision of this document. For browser-based versions of this data sheet, refer to the left-hand navigation.

## PACKAGING INFORMATION

Orderable Device	Status (1)	Package Type	Package Drawing	Pins	Package Qty	Eco Plan (2)	Lead finish/ Ball material (6)	MSL Peak Temp (3)	Op Temp (°C)	Device Marking (4/5)	Samples
5962-8415001VFA	ACTIVE	CFP	W	16	25	Non-RoHS & Green	SNPB	N / A for Pkg Type	-55 to 125	5962-8415001VF A SNV54HC109W	<a href="#">Samples</a>
84150012A	ACTIVE	LCCC	FK	20	55	Non-RoHS & Green	SNPB	N / A for Pkg Type	-55 to 125	84150012A SNJ54HC 109FK	<a href="#">Samples</a>
8415001EA	ACTIVE	CDIP	J	16	25	Non-RoHS & Green	SNPB	N / A for Pkg Type	-55 to 125	8415001EA SNJ54HC109J	<a href="#">Samples</a>
8415001FA	ACTIVE	CFP	W	16	25	Non-RoHS & Green	SNPB	N / A for Pkg Type	-55 to 125	8415001FA SNJ54HC109W	<a href="#">Samples</a>
JM38510/65304BEA	ACTIVE	CDIP	J	16	25	Non-RoHS & Green	SNPB	N / A for Pkg Type	-55 to 125	JM38510/ 65304BEA	<a href="#">Samples</a>
M38510/65304BEA	ACTIVE	CDIP	J	16	25	Non-RoHS & Green	SNPB	N / A for Pkg Type	-55 to 125	JM38510/ 65304BEA	<a href="#">Samples</a>
SN54HC109J	ACTIVE	CDIP	J	16	25	Non-RoHS & Green	SNPB	N / A for Pkg Type	-55 to 125	SN54HC109J	<a href="#">Samples</a>
SN74HC109DR	ACTIVE	SOIC	D	16	2500	RoHS & Green	NIPDAU   SN	Level-1-260C-UNLIM	-40 to 85	HC109	<a href="#">Samples</a>
SN74HC109DRG4	ACTIVE	SOIC	D	16	2500	RoHS & Green	NIPDAU	Level-1-260C-UNLIM	-40 to 85	HC109	<a href="#">Samples</a>
SN74HC109N	ACTIVE	PDIP	N	16	25	RoHS & Green	NIPDAU	N / A for Pkg Type	-40 to 85	SN74HC109N	<a href="#">Samples</a>
SN74HC109NE4	ACTIVE	PDIP	N	16	25	RoHS & Green	NIPDAU	N / A for Pkg Type	-40 to 85	SN74HC109N	<a href="#">Samples</a>
SN74HC109NSR	ACTIVE	SO	NS	16	2000	RoHS & Green	NIPDAU	Level-1-260C-UNLIM	-40 to 85	HC109	<a href="#">Samples</a>
SNJ54HC109FK	ACTIVE	LCCC	FK	20	55	Non-RoHS & Green	SNPB	N / A for Pkg Type	-55 to 125	84150012A SNJ54HC 109FK	<a href="#">Samples</a>
SNJ54HC109J	ACTIVE	CDIP	J	16	25	Non-RoHS & Green	SNPB	N / A for Pkg Type	-55 to 125	8415001EA SNJ54HC109J	<a href="#">Samples</a>
SNJ54HC109W	ACTIVE	CFP	W	16	25	Non-RoHS & Green	SNPB	N / A for Pkg Type	-55 to 125	8415001FA SNJ54HC109W	<a href="#">Samples</a>

(1) The marketing status values are defined as follows:  
**ACTIVE:** Product device recommended for new designs.

**LIFEBUY:** TI has announced that the device will be discontinued, and a lifetime-buy period is in effect.

**NRND:** Not recommended for new designs. Device is in production to support existing customers, but TI does not recommend using this part in a new design.

**PREVIEW:** Device has been announced but is not in production. Samples may or may not be available.

**OBSOLETE:** TI has discontinued the production of the device.

<sup>(2)</sup> **RoHS:** TI defines "RoHS" to mean semiconductor products that are compliant with the current EU RoHS requirements for all 10 RoHS substances, including the requirement that RoHS substance do not exceed 0.1% by weight in homogeneous materials. Where designed to be soldered at high temperatures, "RoHS" products are suitable for use in specified lead-free processes. TI may reference these types of products as "Pb-Free".

**RoHS Exempt:** TI defines "RoHS Exempt" to mean products that contain lead but are compliant with EU RoHS pursuant to a specific EU RoHS exemption.

**Green:** TI defines "Green" to mean the content of Chlorine (Cl) and Bromine (Br) based flame retardants meet JS709B low halogen requirements of  $\leq 1000$ ppm threshold. Antimony trioxide based flame retardants must also meet the  $\leq 1000$ ppm threshold requirement.

<sup>(3)</sup> MSL, Peak Temp. - The Moisture Sensitivity Level rating according to the JEDEC industry standard classifications, and peak solder temperature.

<sup>(4)</sup> There may be additional marking, which relates to the logo, the lot trace code information, or the environmental category on the device.

<sup>(5)</sup> Multiple Device Markings will be inside parentheses. Only one Device Marking contained in parentheses and separated by a "~" will appear on a device. If a line is indented then it is a continuation of the previous line and the two combined represent the entire Device Marking for that device.

<sup>(6)</sup> Lead finish/Ball material - Orderable Devices may have multiple material finish options. Finish options are separated by a vertical ruled line. Lead finish/Ball material values may wrap to two lines if the finish value exceeds the maximum column width.

**Important Information and Disclaimer:** The information provided on this page represents TI's knowledge and belief as of the date that it is provided. TI bases its knowledge and belief on information provided by third parties, and makes no representation or warranty as to the accuracy of such information. Efforts are underway to better integrate information from third parties. TI has taken and continues to take reasonable steps to provide representative and accurate information but may not have conducted destructive testing or chemical analysis on incoming materials and chemicals. TI and TI suppliers consider certain information to be proprietary, and thus CAS numbers and other limited information may not be available for release.

In no event shall TI's liability arising out of such information exceed the total purchase price of the TI part(s) at issue in this document sold by TI to Customer on an annual basis.

**OTHER QUALIFIED VERSIONS OF SN54HC109, SN54HC109-SP, SN74HC109 :**

● Catalog : [SN74HC109](#), [SN54HC109](#)

● Military : [SN54HC109](#)

● Space : [SN54HC109-SP](#)

NOTE: Qualified Version Definitions:

- Catalog - TI's standard catalog product
- Military - QML certified for Military and Defense Applications
- Space - Radiation tolerant, ceramic packaging and qualified for use in Space-based application

**TAPE AND REEL INFORMATION**

**QUADRANT ASSIGNMENTS FOR PIN 1 ORIENTATION IN TAPE**

\*All dimensions are nominal

Device	Package Type	Package Drawing	Pins	SPQ	Reel Diameter (mm)	Reel Width W1 (mm)	A0 (mm)	B0 (mm)	K0 (mm)	P1 (mm)	W (mm)	Pin1 Quadrant
SN74HC109DR	SOIC	D	16	2500	330.0	16.4	6.5	10.3	2.1	8.0	16.0	Q1
SN74HC109NSR	SO	NS	16	2000	330.0	16.4	8.2	10.5	2.5	12.0	16.0	Q1

**TAPE AND REEL BOX DIMENSIONS**

\*All dimensions are nominal

Device	Package Type	Package Drawing	Pins	SPQ	Length (mm)	Width (mm)	Height (mm)
SN74HC109DR	SOIC	D	16	2500	356.0	356.0	35.0
SN74HC109NSR	SO	NS	16	2000	356.0	356.0	35.0

**TUBE**

\*All dimensions are nominal

Device	Package Name	Package Type	Pins	SPQ	L (mm)	W (mm)	T (μm)	B (mm)
5962-8415001VFA	W	CFP	16	25	506.98	26.16	6220	NA
84150012A	FK	LCCC	20	55	506.98	12.06	2030	NA
8415001FA	W	CFP	16	25	506.98	26.16	6220	NA
SN74HC109N	N	PDIP	16	25	506	13.97	11230	4.32
SN74HC109N	N	PDIP	16	25	506	13.97	11230	4.32
SN74HC109NE4	N	PDIP	16	25	506	13.97	11230	4.32
SN74HC109NE4	N	PDIP	16	25	506	13.97	11230	4.32
SNJ54HC109FK	FK	LCCC	20	55	506.98	12.06	2030	NA
SNJ54HC109W	W	CFP	16	25	506.98	26.16	6220	NA

W (R-GDFP-F16)

CERAMIC DUAL FLATPACK

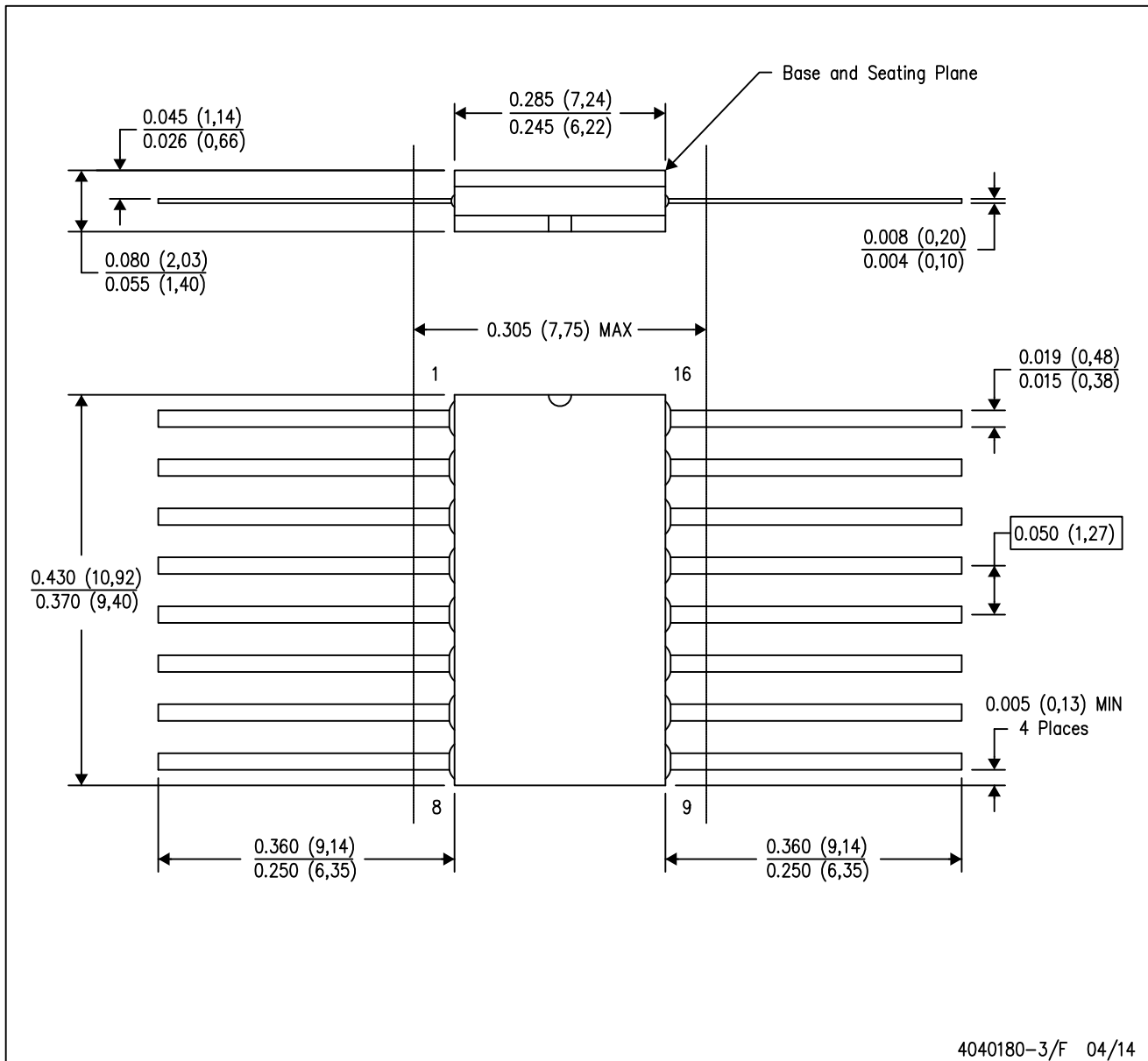

- NOTES:
- A. All linear dimensions are in inches (millimeters).
  - B. This drawing is subject to change without notice.
  - C. This package can be hermetically sealed with a ceramic lid using glass frit.
  - D. Index point is provided on cap for terminal identification only.
  - E. Falls within MIL STD 1835 GDFP2-F16

## GENERIC PACKAGE VIEW

**FK 20**

**LCCC - 2.03 mm max height**

8.89 x 8.89, 1.27 mm pitch

LEADLESS CERAMIC CHIP CARRIER

This image is a representation of the package family, actual package may vary.  
Refer to the product data sheet for package details.



4229370VA\

J (R-GDIP-T\*\*)

14 LEADS SHOWN

CERAMIC DUAL IN-LINE PACKAGE



DIM \ PINS **	14	16	18	20
A	0.300 (7,62) BSC	0.300 (7,62) BSC	0.300 (7,62) BSC	0.300 (7,62) BSC
B MAX	0.785 (19,94)	.840 (21,34)	0.960 (24,38)	1.060 (26,92)
B MIN	—	—	—	—
C MAX	0.300 (7,62)	0.300 (7,62)	0.310 (7,87)	0.300 (7,62)
C MIN	0.245 (6,22)	0.245 (6,22)	0.220 (5,59)	0.245 (6,22)



4040083/F 03/03

- NOTES:
- All linear dimensions are in inches (millimeters).
  - This drawing is subject to change without notice.
  - This package is hermetically sealed with a ceramic lid using glass frit.
  - Index point is provided on cap for terminal identification only on press ceramic glass frit seal only.
  - Falls within MIL STD 1835 GDIP1-T14, GDIP1-T16, GDIP1-T18 and GDIP1-T20.

N (R-PDIP-T\*\*)

PLASTIC DUAL-IN-LINE PACKAGE

16 PINS SHOWN



- NOTES:
- A. All linear dimensions are in inches (millimeters).
  - B. This drawing is subject to change without notice.
  - Falls within JEDEC MS-001, except 18 and 20 pin minimum body length (Dim A).
  - The 20 pin end lead shoulder width is a vendor option, either half or full width.

4040049/E 12/2002



# PACKAGE OUTLINE

## NS0016A

### SOP - 2.00 mm max height

SOP

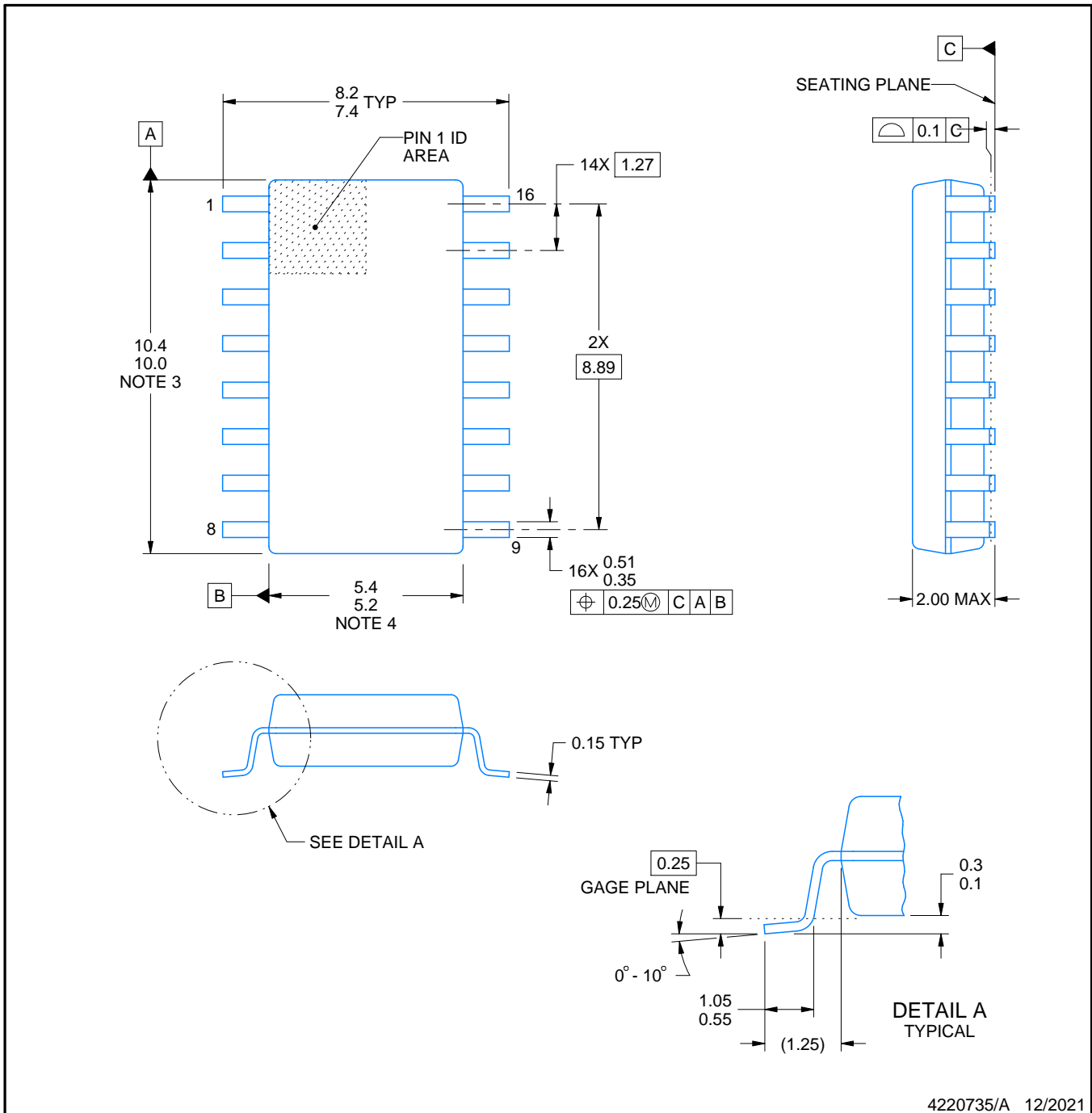

4220735/A 12/2021

#### NOTES:

1. All linear dimensions are in millimeters. Dimensions in parenthesis are for reference only. Dimensioning and tolerancing per ASME Y14.5M.
2. This drawing is subject to change without notice.
3. This dimension does not include mold flash, protrusions, or gate burrs. Mold flash, protrusions, or gate burrs shall not exceed 0.15 mm, per side.
4. This dimension does not include interlead flash. Interlead flash shall not exceed 0.25 mm, per side.

# EXAMPLE BOARD LAYOUT

NS0016A

SOP - 2.00 mm max height

SOP



4220735/A 12/2021

NOTES: (continued)

5. Publication IPC-7351 may have alternate designs.

6. Solder mask tolerances between and around signal pads can vary based on board fabrication site.



D (R-PDSO-G16)

PLASTIC SMALL OUTLINE



- NOTES:
- A. All linear dimensions are in inches (millimeters).
  - B. This drawing is subject to change without notice.
  - C. Body length does not include mold flash, protrusions, or gate burrs. Mold flash, protrusions, or gate burrs shall not exceed 0.006 (0,15) each side.
  - D. Body width does not include interlead flash. Interlead flash shall not exceed 0.017 (0,43) each side.
  - E. Reference JEDEC MS-012 variation AC.

# MECHANICAL DATA

NS (R-PDSO-G\*\*)

PLASTIC SMALL-OUTLINE PACKAGE

14-PINS SHOWN



- NOTES:
- A. All linear dimensions are in millimeters.
  - B. This drawing is subject to change without notice.
  - C. Body dimensions do not include mold flash or protrusion, not to exceed 0,15.

## IMPORTANT NOTICE AND DISCLAIMER

TI PROVIDES TECHNICAL AND RELIABILITY DATA (INCLUDING DATA SHEETS), DESIGN RESOURCES (INCLUDING REFERENCE DESIGNS), APPLICATION OR OTHER DESIGN ADVICE, WEB TOOLS, SAFETY INFORMATION, AND OTHER RESOURCES "AS IS" AND WITH ALL FAULTS, AND DISCLAIMS ALL WARRANTIES, EXPRESS AND IMPLIED, INCLUDING WITHOUT LIMITATION ANY IMPLIED WARRANTIES OF MERCHANTABILITY, FITNESS FOR A PARTICULAR PURPOSE OR NON-INFRINGEMENT OF THIRD PARTY INTELLECTUAL PROPERTY RIGHTS.

These resources are intended for skilled developers designing with TI products. You are solely responsible for (1) selecting the appropriate TI products for your application, (2) designing, validating and testing your application, and (3) ensuring your application meets applicable standards, and any other safety, security, regulatory or other requirements.

These resources are subject to change without notice. TI grants you permission to use these resources only for development of an application that uses the TI products described in the resource. Other reproduction and display of these resources is prohibited. No license is granted to any other TI intellectual property right or to any third party intellectual property right. TI disclaims responsibility for, and you will fully indemnify TI and its representatives against, any claims, damages, costs, losses, and liabilities arising out of your use of these resources.

TI's products are provided subject to [TI's Terms of Sale](#) or other applicable terms available either on [ti.com](https://www.ti.com) or provided in conjunction with such TI products. TI's provision of these resources does not expand or otherwise alter TI's applicable warranties or warranty disclaimers for TI products.

TI objects to and rejects any additional or different terms you may have proposed.

Mailing Address: Texas Instruments, Post Office Box 655303, Dallas, Texas 75265  
Copyright © 2024, Texas Instruments Incorporated

## Looking for pricing, stock, or lifecycle information?

Click below to explore more details on WIN SOURCE:

 [View SN74HC109NSR on WIN SOURCE](#)

 [Texas Instruments](#) Information

## Optimize Your Supply Chain with WIN SOURCE Solutions

-  Global Sourcing Solution
-  Obsolete Management
-  Cost Control Management
-  Shortage Management
-  Alternative Solution
-  Excess Inventory Management