



**THE DATASHEET OF
SN74FB1653PCA**



SN74FB1653

17-BIT LVTTTL/BTL UNIVERSAL STORAGE TRANSCEIVER WITH BUFFERED CLOCK LINE

SCBS702H – AUGUST 1997 – REVISED MARCH 2004

description/ordering information

The SN74FB1653 contains an 8-bit and a 9-bit transceiver with a buffered clock. The clock and transceivers are designed to translate signals between LVTTTL and BTL environments. The device is designed specifically to be compatible with IEEE Std 1194.1-1991 (BTL).

The A port operates at LVTTTL signal levels. The A outputs reflect the inverse of the data at the \bar{B} port when the A-port output enable (OEA) is high. When OEA is low or when V_{CC} (5 V) typically is less than 2.5 V, the A outputs are in the high-impedance state.

The \bar{B} port operates at BTL signal levels. The open-collector \bar{B} ports are specified to sink 100 mA. Two output enables (OEB and \overline{OEB}) are provided for the \bar{B} outputs. When OEB is low, \overline{OEB} is high, or V_{CC} (5 V) typically is less than 2.5 V, the \bar{B} port is turned off.

The clock-select (2SEL1 and 2SEL2) inputs are used to configure the TTL-to-BTL clock paths and delays (refer to the *MUX-MODE DELAY* table).

BIAS V_{CC} establishes a voltage between 1.62 V and 2.1 V on the BTL outputs when V_{CC} (5 V) is not connected.

BG V_{CC} and BG GND are the supply inputs for the bias generator.

V_{REF} is an internally generated voltage source. It is recommended that V_{REF} be decoupled with an external 0.1- μ F capacitor.

Enhanced heat-dissipation techniques should be used when operating this device from A1 to A0 at frequencies greater than 50 MHz, or from A1 to \bar{B} or \bar{B} to A0 at frequencies greater than 100 MHz.

ORDERING INFORMATION

TA	PACKAGE†		ORDERABLE PART NUMBER	TOP-SIDE MARKING
0°C to 70°C	TQFP – PCA	Tube	SN74FB1653PCA	FB1653

† Package drawings, standard packing quantities, thermal data, symbolization, and PCB design guidelines are available at www.ti.com/sc/package.

Function Tables

TRANSCEIVER

INPUTS				FUNCTION
\overline{OEA}	OEA	OEB	\overline{OEB}	
X	X	H	L	\bar{A} data to B bus
L	H	X	X	\bar{B} data to A bus
L	H	H	L	\bar{A} data to B bus, \bar{B} data to A bus
X	X	L	X	B-bus isolation
X	X	X	H	
H	X	X	X	A-bus isolation
X	L	X	X	

STORAGE MODE

INPUTS		FUNCTION
LE	CLK	
H	X	Transparent
L	↑	Store data
L	L	Storage



SN74FB1653
17-BIT LVTTTL/BTL UNIVERSAL STORAGE TRANSCIEVER
WITH BUFFERED CLOCK LINE

SCBS702H - AUGUST 1997 - REVISED MARCH 2004

functional block diagram

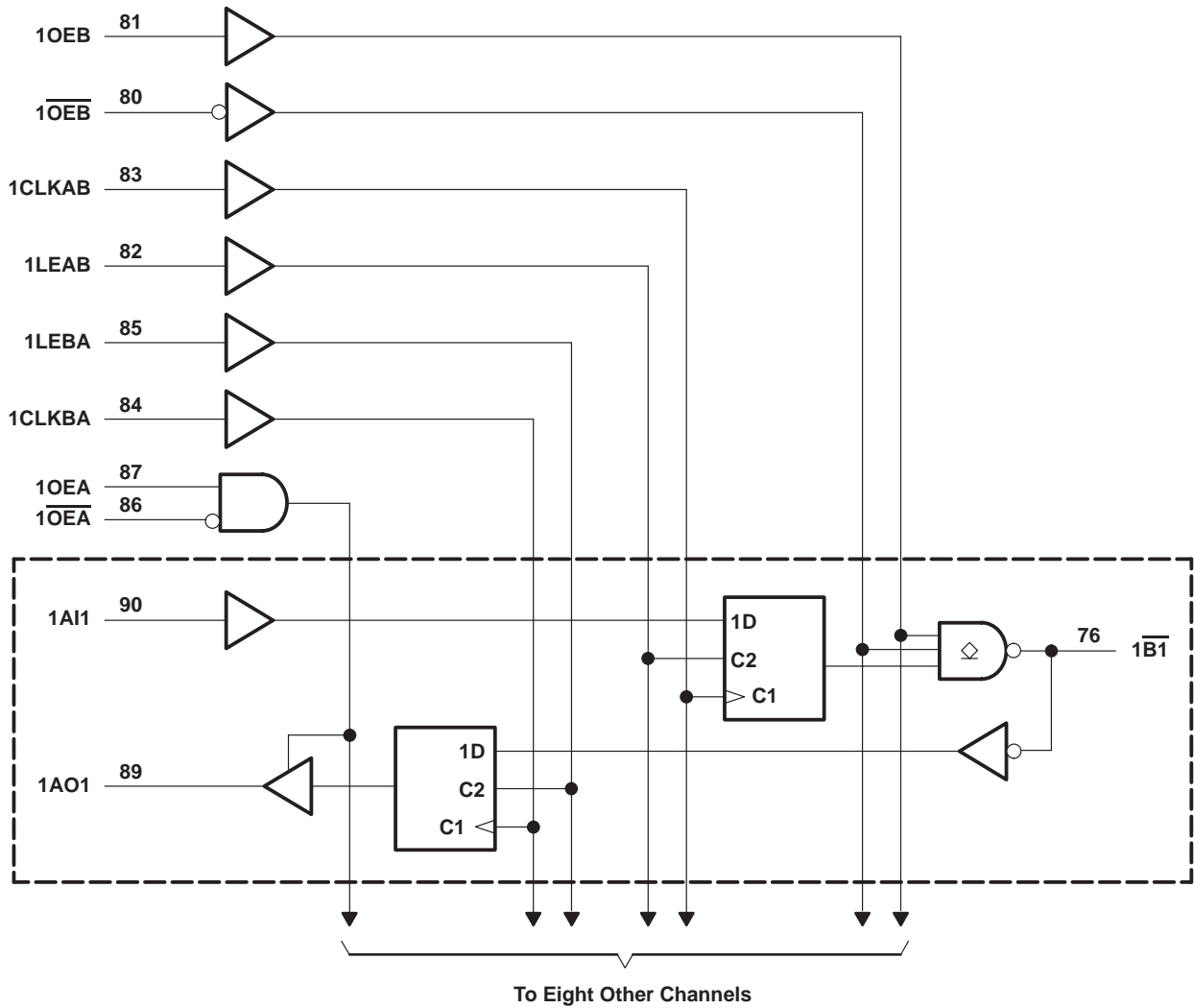

SN74FB1653
17-BIT LVTTL/BTL UNIVERSAL STORAGE TRANSCEIVER
WITH BUFFERED CLOCK LINE

SCBS702H – AUGUST 1997 – REVISED MARCH 2004

functional block diagram (continued)

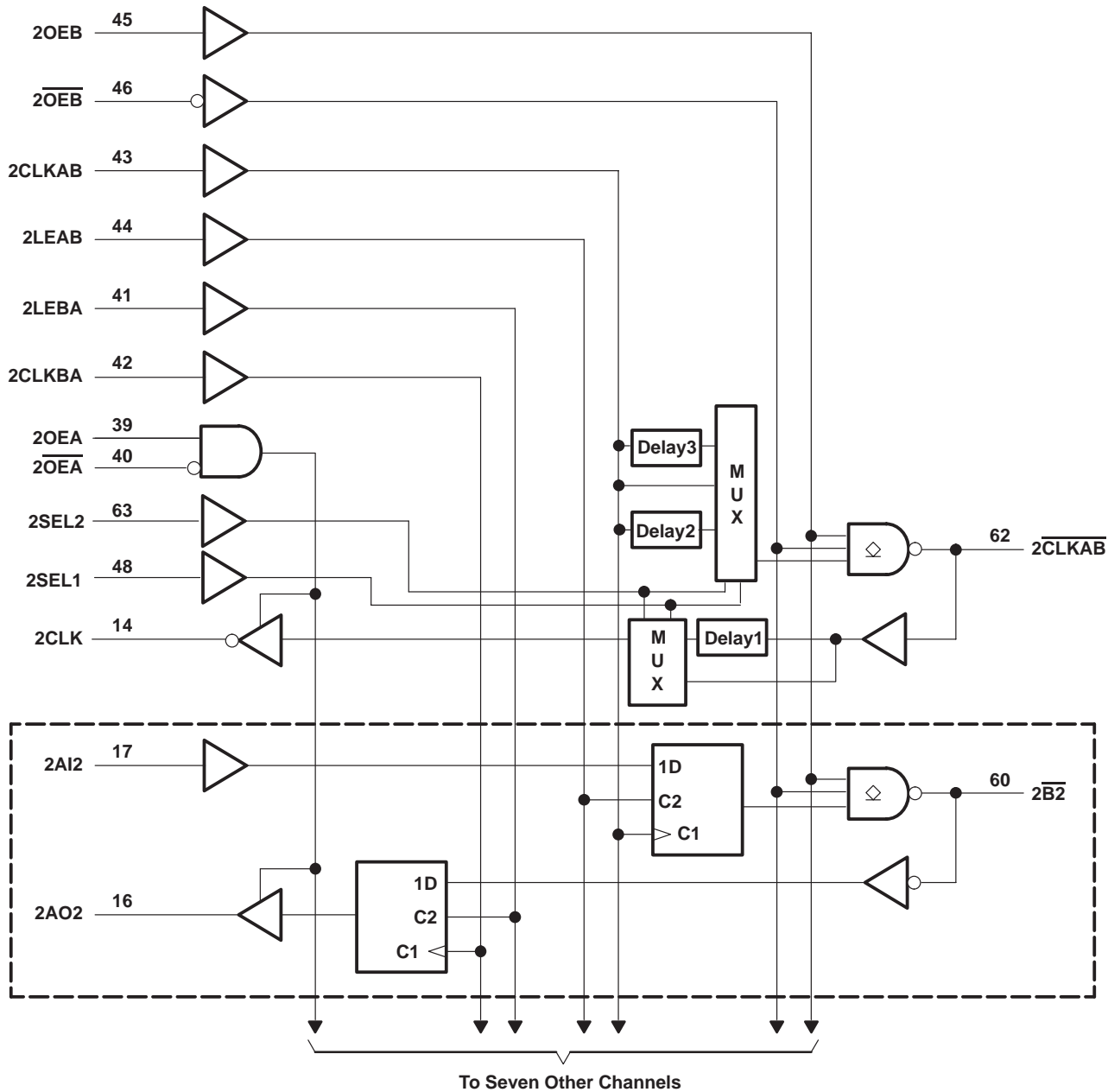

MUX-MODE DELAY

INPUTS		DELAY PATH†	
2SEL1	2SEL2	2CLKAB TO 2CLKAB	2CLKAB TO 2CLK
L	L	No delay	No delay
L	H	No delay	Delay1
H	L	Delay2	Delay1
H	H	Delay3	Delay1

† Refer to delay1 through delay3 in the functional block diagram.

SN74FB1653

17-BIT LVTTTL/BTL UNIVERSAL STORAGE TRANSCEIVER WITH BUFFERED CLOCK LINE

SCBS702H – AUGUST 1997 – REVISED MARCH 2004

absolute maximum ratings over operating free-air temperature range (unless otherwise noted)†

Supply voltage range: $V_{CC}(5\text{ V})$, BIAS V_{CC} , BG V_{CC}	–0.5 V to 7 V
$V_{CC}(3.3\text{ V})$	–0.5 V to 4.6 V
Input voltage range, V_I : Except \overline{B} port	–1.2 V to 7 V
\overline{B} port	–1.2 V to 3.5 V
Input clamp current, I_{IK} : Except \overline{B} port	–40 mA
\overline{B} port	–18 mA
Voltage range applied to any \overline{B} output in the disabled or power-off state	–0.5 V to 3.5 V
Voltage range applied to any output in the high state	–0.5 V to V_{CC}
Current applied to any single output in the low state: A port	48 mA
\overline{B} port	200 mA
Package thermal impedance, θ_{JA} (see Note 1)	22°C/W
Storage temperature range, T_{stg}	–65°C to 150°C

† Stresses beyond those listed under “absolute maximum ratings” may cause permanent damage to the device. These are stress ratings only, and functional operation of the device at these or any other conditions beyond those indicated under “recommended operating conditions” is not implied. Exposure to absolute-maximum-rated conditions for extended periods may affect device reliability.

NOTE 1: The package thermal impedance is calculated in accordance with JESD 51-7.

recommended operating conditions (see Note 2)

		MIN	NOM	MAX	UNIT
V_{CC} , BG V_{CC} , BIAS V_{CC}	Supply voltage	4.5	5	5.5	V
$V_{CC}(3.3\text{ V})$	Supply voltage	3	3.3	3.6	V
V_{IH}	High-level input voltage	\overline{B} port	1.62	2.3	V
		Except \overline{B} port	2		
V_{IL}	Low-level input voltage	\overline{B} port	0.75	1.47	V
		Except \overline{B} port		0.8	
I_{IK}	Input clamp current			–18	mA
I_{OH}	High-level output current			–3	mA
I_{OL}	Low-level output current	AO port		24	mA
		\overline{B} port		100	
T_A	Operating free-air temperature	0		70	°C

NOTE 2: To ensure proper device operation, all unused inputs must be terminated as follows: A and control inputs to $V_{CC}(5\text{ V})$ or GND, and B inputs to GND only. Refer to the TI application report, *Implications of Slow or Floating CMOS Inputs*, literature number SCBA004.



SN74FB1653
17-BIT LVTTL/BTL UNIVERSAL STORAGE TRANSCEIVER
WITH BUFFERED CLOCK LINE

SCBS702H – AUGUST 1997 – REVISED MARCH 2004

electrical characteristics over recommended operating free-air temperature range

PARAMETER		TEST CONDITIONS		MIN	TYP†	MAX	UNIT
V _{IK}	\overline{B} port	V _{CC} (5 V) = 4.5 V, V _{CC} (3.3 V) = 3.3 V	I _I = -18 mA			-1.2	V
	Except \overline{B} port		I _I = -40 mA			-0.5	
V _{OH}	AO port	V _{CC} (5 V) = 4.5 V, V _{CC} (3.3 V) = 3 V	I _{OH} = -3 mA	2.5			V
V _{OL}	AO port	V _{CC} (5 V) = 4.5 V, V _{CC} (3.3 V) = 3 V	I _{OL} = 24 mA	0.35		0.5	V
	\overline{B} port	V _{CC} (5 V) = 4.5 V, V _{CC} (3.3 V) = 3 V	I _{OL} = 80 mA I _{OL} = 100 mA	0.75		1.1 1.15	
I _I	Except \overline{B} port	V _{CC} (5 V) = 5.5 V, V _{CC} (3.3 V) = 3.6 V	V _I = 5.5 V			50	μA
I _{IH} ‡	Except \overline{B} port	V _{CC} (5 V) = 5.5 V, V _{CC} (3.3 V) = 3.6 V	V _I = 2.7 V			50	μA
I _{IL} ‡	Except \overline{B} port	V _{CC} (5 V) = 5.5 V, V _{CC} (3.3 V) = 3.6 V	V _I = 0.5 V			-50	μA
	\overline{B} port	V _{CC} (5 V) = 5.5 V, V _{CC} (3.3 V) = 3.6 V	V _I = 0.75 V			-100	
I _{OH}	\overline{B} port	V _{CC} (5 V) = 0 to 5.5 V, V _{CC} (3.3 V) = 3.6 V	V _O = 2.1 V			100	μA
I _{OZH}	AO port	V _{CC} (5 V) = 5.5 V, V _{CC} (3.3 V) = 3.6 V	V _O = 2.7 V			50	μA
I _{OZL}	AO port	V _{CC} (5 V) = 5.5 V, V _{CC} (3.3 V) = 3.6 V	V _O = 0.5 V			-50	μA
I _{OZPU}	AO port	V _{CC} = 0 to 2.1 V,	V _O = 0.5 V to 2.7 V			-50	μA
I _{OZPD}	AO port	V _{CC} = 2.1 V to 0,	V _O = 0.5 V to 2.7 V			-50	μA
I _{CC} (5 V)	AI port to \overline{B} port	V _{CC} (5 V) = 5.5 V, V _{CC} (3.3 V) = 3.3 V	I _O = 0			145	mA
	\overline{B} port to AO port					130	
	Outputs disabled					120	
I _{CC} (3.3 V)	\overline{B} port to AO port	V _{CC} (5 V) = 5.5 V, V _{CC} (3.3 V) = 3.3 V	I _O = 0			1	mA
C _i	Control and AI inputs	V _I = 0.5 V or 2.5 V			6.5		pF
C _o	AO port	V _O = 0.5 V or 2.5 V			3.5		pF
C _{io}	\overline{B} port per IEEE Std 1194.1-1991	V _{CC} (5 V) = 0 to 5.5 V, V _{CC} (3.3 V) = 3.3 V				6.5	pF

† All typical values are at V_{CC}(5 V) = 5 V and V_{CC}(3.3 V) = 3.3 V, T_A = 25°C.

‡ For I/O ports, the parameters I_{IH} and I_{IL} include the off-state output current.



SN74FB1653
17-BIT LVTTTL/BTL UNIVERSAL STORAGE TRANSCEIVER
WITH BUFFERED CLOCK LINE

SCBS702H – AUGUST 1997 – REVISED MARCH 2004

live-insertion specifications over recommended operating free-air temperature range

PARAMETER		TEST CONDITIONS		MIN	MAX	UNIT
I_{CC} (BIAS V_{CC})		$V_{CC}(5\text{ V}) = 0$ to 4.5 V, $V_{CC}(3.3\text{ V}) = 3.3\text{ V}$	$V_B = 0$ to 2 V, V_I (BIAS V_{CC}) = 4.5 V to 5.5 V	450		μA
		$V_{CC}(5\text{ V}) = 4.5\text{ V}$ to 5.5 V, $V_{CC}(3.3\text{ V}) = 3.3\text{ V}$		10		
V_O	\overline{B} port	$V_{CC}(5\text{ V}) = 0$, $V_{CC}(3.3\text{ V}) = 0\text{ V}$	V_I (BIAS V_{CC}) = 5 V	1.62	2.1	V
I_O	\overline{B} port	$V_{CC}(5\text{ V}) = 0$, $V_{CC}(3.3\text{ V}) = 0\text{ V}$	$V_B = 1\text{ V}$, V_I (BIAS V_{CC}) = 4.5 V to 5.5 V	–1		μA
		$V_{CC}(5\text{ V}) = 0$ to 2.2 V, $V_{CC}(3.3\text{ V}) = 3.3\text{ V}$	OEB = 0 to 5 V	100		
		$V_{CC}(5\text{ V}) = 0$ to 5.5 V, $V_{CC}(3.3\text{ V}) = 3.3\text{ V}$	OEB = 0 to 0.8 V	1		mA

timing requirements over recommended ranges of supply voltage and operating free-air temperature (unless otherwise noted) (see Figure 1)

			MIN	MAX	UNIT
f_{clock}	Clock frequency		90		MHz
t_w	Pulse duration	LE high	3		ns
		CLK high or low	3		
t_{su}	Setup time	AI or \overline{B} before LE \downarrow	3.5		ns
		AI or \overline{B} before CLK \uparrow	3.5		
t_h	Hold time	AI or \overline{B} after LE \downarrow	1		ns
		AI or \overline{B} after CLK \uparrow	0.7		



SN74FB1653
17-BIT LVTTL/BTL UNIVERSAL STORAGE TRANSCEIVER
WITH BUFFERED CLOCK LINE

SCBS702H – AUGUST 1997 – REVISED MARCH 2004

switching characteristics over recommended operating free-air temperature range,
 $V_{CC}(5\text{ V}) = 5\text{ V} \pm 0.5\text{ V}$ and $V_{CC}(3.3\text{ V}) = 3.3\text{ V}$ (see Figure 1)

PARAMETER	FROM (INPUT)	TO (OUTPUT)	MIN	MAX	UNIT
f_{\max}			90		MHz
t_{PLH}	AI	\overline{B}	1.8	6.2	ns
t_{PHL}			2.9	6.6	
t_{PLH}	LEAB	\overline{B}	2.7	6.9	ns
t_{PHL}			3.5	7.3	
t_{PLH}	CLKAB	\overline{B}	2.3	6.4	ns
t_{PHL}			2.9	6.7	
t_{PLH}	2CLKAB (no delay)	$\overline{2CLKAB}$	2.3	6	ns
t_{PHL}			2.9	6.7	
t_{PLH}	2CLKAB (delay2)	$\overline{2CLKAB}$	4.5	9.5	ns
t_{PHL}			4.5	9.5	
t_{PLH}	2CLKAB (delay3)	$\overline{2CLKAB}$	9.3	15.4	ns
t_{PHL}			9.3	15.4	
t_{PLH}	\overline{B}	AO	2	6.5	ns
t_{PHL}			2	6.5	
t_{PLH}	LEBA	AO	1.8	6.3	ns
t_{PHL}			1.8	6.3	
t_{PLH}	CLKBA	AO	1.8	6.3	ns
t_{PHL}			1.8	6.3	
t_{PLH}	$\overline{2CLKAB}$ (delay1)	2CLK	5.7	12.3	ns
t_{PHL}			5.7	12.3	
t_{PLH}	$\overline{2CLKAB}$ (no delay)	2CLK	2	6.5	ns
t_{PHL}			2	6.5	
t_{PLH}	OEB or \overline{OEB}	\overline{B}	2.6	7	ns
t_{PHL}			2.6	7	
t_{PZH}	OEA or \overline{OEA}	AO	1.4	5.5	ns
t_{PZL}			1.4	5.5	
t_{PHZ}	OEA or \overline{OEA}	AO	1.4	6.5	ns
t_{PLZ}			1.4	5.8	
$t_{sk(p)}^{\dagger}$	Pulse skew, AI to \overline{B} or \overline{B} to AO		1.6		ns
	Pulse skew, $\overline{2CLKAB}$ to 2CLK		1.8		
$t_{sk(p)}$	Pulse skew, CLKAB to \overline{B} or CLKBA to AO		1.5		ns
	Pulse skew, CLKAB to $\overline{2CLKAB}$		1.4		
$t_{sk(HL)}, t_{sk(LH)}^{\dagger}$	Output skew, AI to \overline{B} or \overline{B} to AO		1		ns
$t_{sk(o)}^{\ddagger}$	Output skew, nondelayed mode for $\overline{2CLKAB}$, CLKAB to AO		1		ns
	Output skew, nondelayed mode for $\overline{2CLKAB}$, CLKAB to \overline{B} and $\overline{2CLKAB}$		1		
$t_{sk(o)}^{\ddagger}$	Output skew, nondelayed mode for $\overline{2CLKAB}$, CLKAB to \overline{B} and $\overline{2CLKAB}$		1.5		ns
t_t	Transition time, \overline{B} outputs (1.3 V to 1.8 V)		0.5	4.6	ns
	Transition time, AO outputs (10% to 90%)		0.4	4.2	
t_{PR}	\overline{B} -port input pulse rejection		1		ns

\dagger Skew values are applicable for through mode only, with single-output switching.

\ddagger Skew values are applicable for CLK mode only, with all outputs simultaneously switching high-to-low or low-to-high.



PARAMETER MEASUREMENT INFORMATION

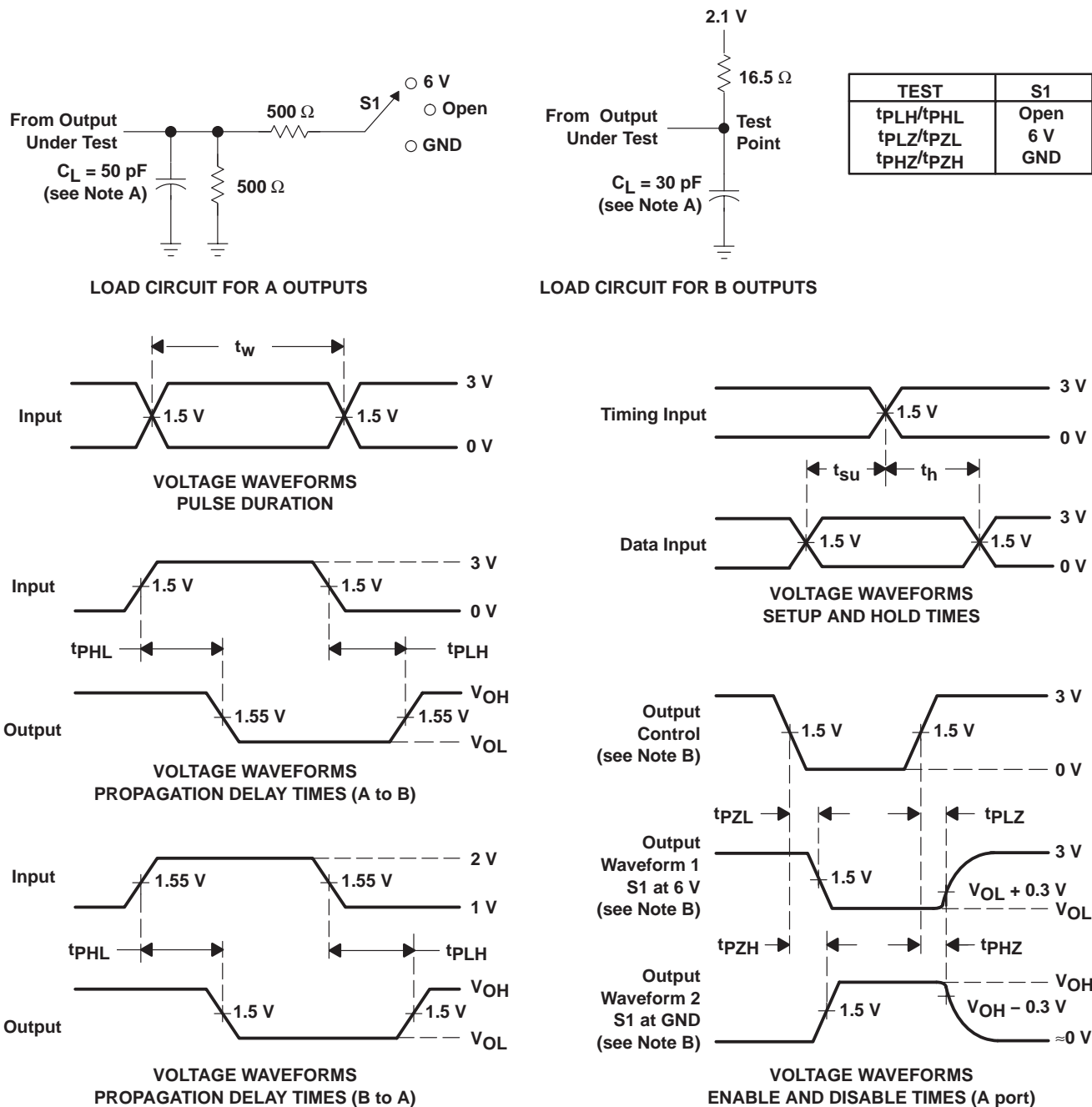

- NOTES: A. C_L includes probe and jig capacitance.
 B. Waveform 1 is for an output with internal conditions such that the output is low, except when disabled by the output control. Waveform 2 is for an output with internal conditions such that the output is high, except when disabled by the output control.
 C. All input pulses are supplied by generators having the following characteristics: TTL inputs: $PRR \leq 10$ MHz, $Z_O = 50 \Omega$, $t_r \leq 2.5$ ns, $t_f \leq 2.5$ ns; BTL inputs: $PRR \leq 10$ MHz, $Z_O = 50 \Omega$, $t_r \leq 1$ ns, $t_f \leq 1$ ns.
 D. The outputs are measured one at a time, with one transition per measurement.

Figure 1. Load Circuits and Voltage Waveforms

PACKAGING INFORMATION

Orderable Device	Status (1)	Package Type	Package Drawing	Pins	Package Qty	Eco Plan (2)	Lead finish/ Ball material (6)	MSL Peak Temp (3)	Op Temp (°C)	Device Marking (4/5)	Samples
SN74FB1653PCA	ACTIVE	HLQFP	PCA	100	90	RoHS & Green	NIPDAU	Level-3-260C-168 HR	0 to 70	FB1653	Samples

(1) The marketing status values are defined as follows:

ACTIVE: Product device recommended for new designs.

LIFEBUY: TI has announced that the device will be discontinued, and a lifetime-buy period is in effect.

NRND: Not recommended for new designs. Device is in production to support existing customers, but TI does not recommend using this part in a new design.

PREVIEW: Device has been announced but is not in production. Samples may or may not be available.

OBSOLETE: TI has discontinued the production of the device.

(2) **RoHS:** TI defines "RoHS" to mean semiconductor products that are compliant with the current EU RoHS requirements for all 10 RoHS substances, including the requirement that RoHS substance do not exceed 0.1% by weight in homogeneous materials. Where designed to be soldered at high temperatures, "RoHS" products are suitable for use in specified lead-free processes. TI may reference these types of products as "Pb-Free".

RoHS Exempt: TI defines "RoHS Exempt" to mean products that contain lead but are compliant with EU RoHS pursuant to a specific EU RoHS exemption.

Green: TI defines "Green" to mean the content of Chlorine (Cl) and Bromine (Br) based flame retardants meet JS709B low halogen requirements of <=1000ppm threshold. Antimony trioxide based flame retardants must also meet the <=1000ppm threshold requirement.

(3) MSL, Peak Temp. - The Moisture Sensitivity Level rating according to the JEDEC industry standard classifications, and peak solder temperature.

(4) There may be additional marking, which relates to the logo, the lot trace code information, or the environmental category on the device.

(5) Multiple Device Markings will be inside parentheses. Only one Device Marking contained in parentheses and separated by a "-" will appear on a device. If a line is indented then it is a continuation of the previous line and the two combined represent the entire Device Marking for that device.

(6) Lead finish/Ball material - Orderable Devices may have multiple material finish options. Finish options are separated by a vertical ruled line. Lead finish/Ball material values may wrap to two lines if the finish value exceeds the maximum column width.

Important Information and Disclaimer: The information provided on this page represents TI's knowledge and belief as of the date that it is provided. TI bases its knowledge and belief on information provided by third parties, and makes no representation or warranty as to the accuracy of such information. Efforts are underway to better integrate information from third parties. TI has taken and continues to take reasonable steps to provide representative and accurate information but may not have conducted destructive testing or chemical analysis on incoming materials and chemicals. TI and TI suppliers consider certain information to be proprietary, and thus CAS numbers and other limited information may not be available for release.

In no event shall TI's liability arising out of such information exceed the total purchase price of the TI part(s) at issue in this document sold by TI to Customer on an annual basis.

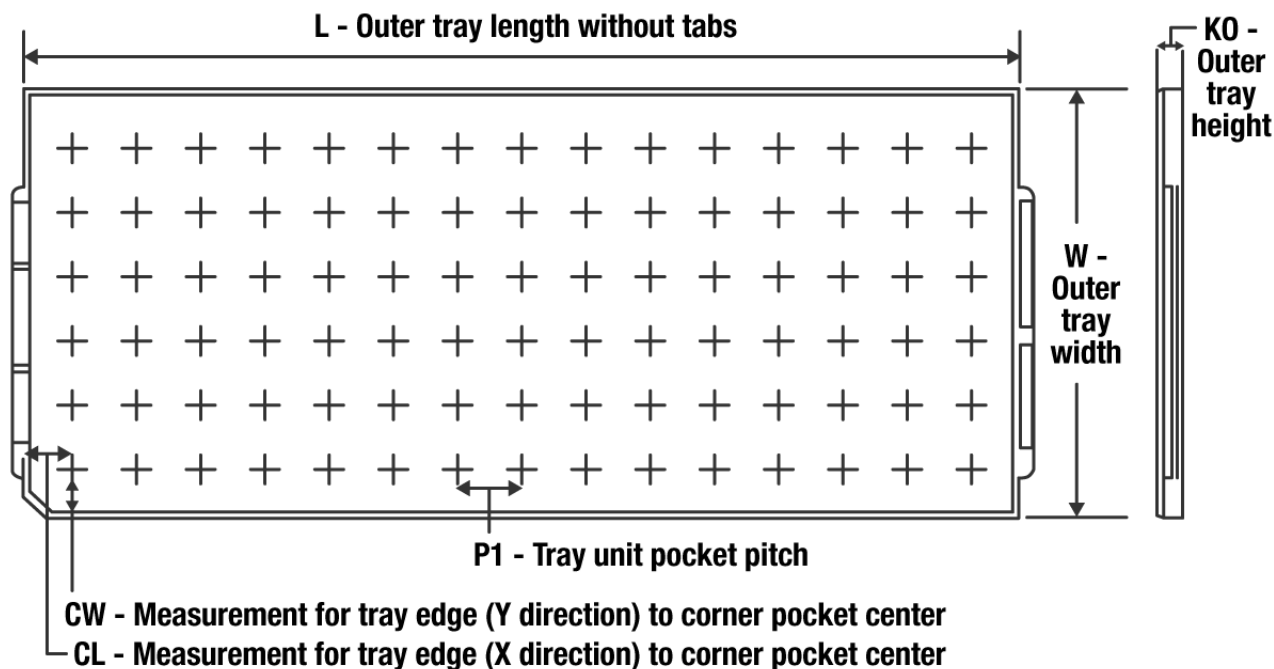
TRAY

Chamfer on Tray corner indicates Pin 1 orientation of packed units.

*All dimensions are nominal

Device	Package Name	Package Type	Pins	SPQ	Unit array matrix	Max temperature (°C)	L (mm)	W (mm)	K0 (µm)	P1 (mm)	CL (mm)	CW (mm)
SN74FB1653PCA	PCA	HLQFP	100	90	6 x 15	150	315	135.9	7620	20.3	15.4	15.45

PCA (S-PQFP-G100)

PLASTIC QUAD FLATPACK (DIE DOWN)

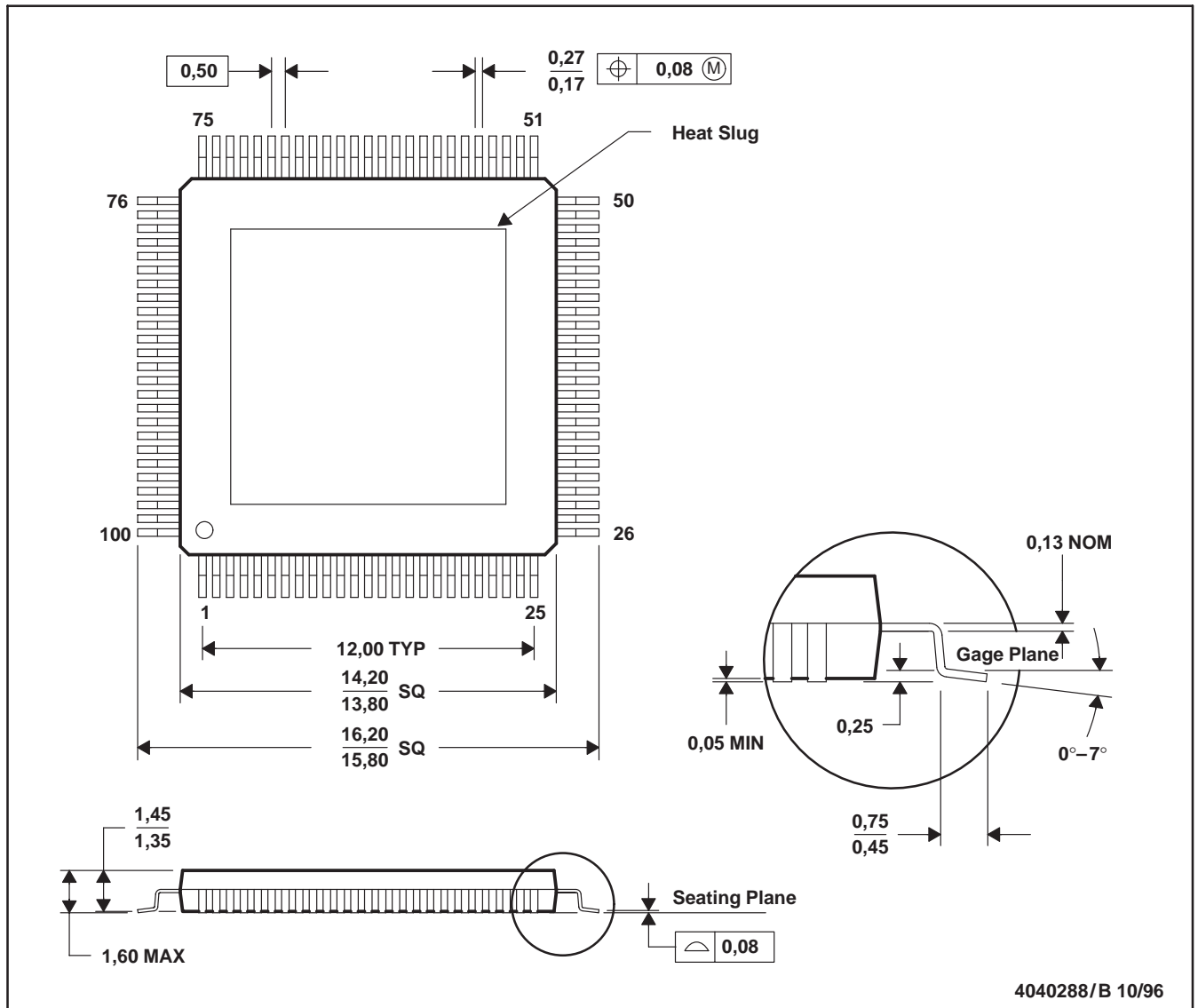

- NOTES: A. All linear dimensions are in millimeters.
 B. This drawing is subject to change without notice.
 C. Thermally enhanced molded plastic package with a heat slug (HSL)
 D. Falls within JEDEC MS-026

THERMAL INFORMATION

This PowerPAD™ package incorporates an exposed thermal pad that is designed to be attached directly to an external heatsink. This design optimizes the heat transfer from the integrated circuit (IC).

For additional information on the PowerPAD package and how to take advantage of its heat dissipating abilities, refer to Technical Brief, PowerPAD Thermally Enhanced Package, Texas Instruments Literature No. SLMA002 and Application Brief, PowerPAD Made Easy, Texas Instruments Literature No. SLMA004. Both documents are available at www.ti.com.

The exposed thermal pad dimensions for this package are shown in the following illustration.

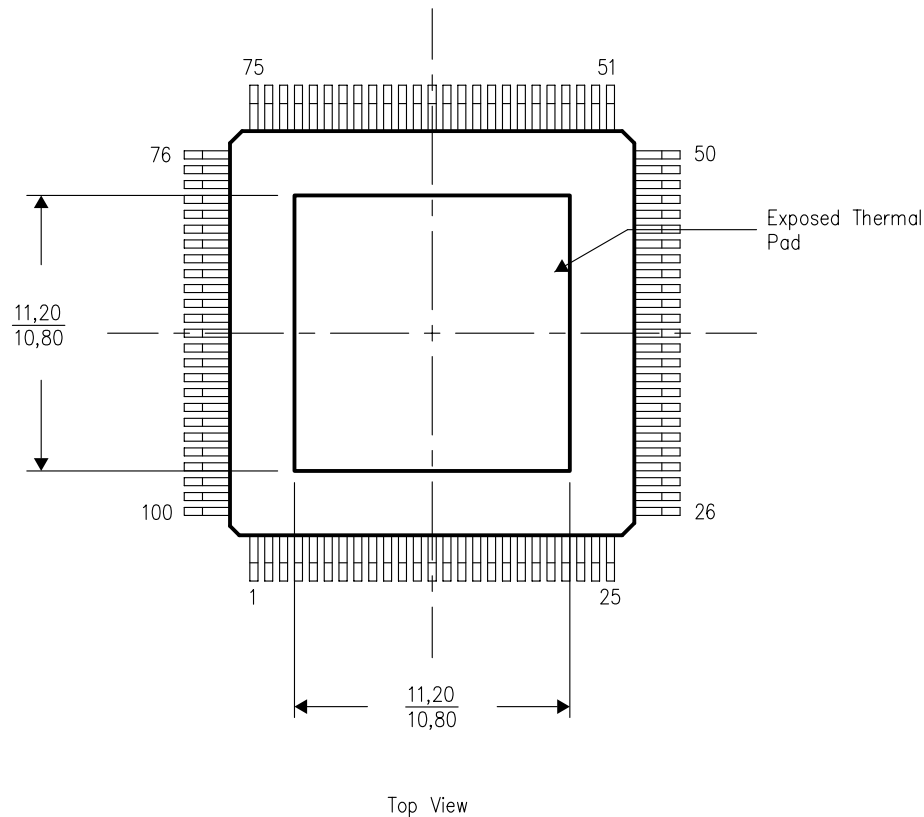

NOTE: All linear dimensions are in millimeters

Exposed Thermal Pad Dimensions

IMPORTANT NOTICE AND DISCLAIMER

TI PROVIDES TECHNICAL AND RELIABILITY DATA (INCLUDING DATA SHEETS), DESIGN RESOURCES (INCLUDING REFERENCE DESIGNS), APPLICATION OR OTHER DESIGN ADVICE, WEB TOOLS, SAFETY INFORMATION, AND OTHER RESOURCES "AS IS" AND WITH ALL FAULTS, AND DISCLAIMS ALL WARRANTIES, EXPRESS AND IMPLIED, INCLUDING WITHOUT LIMITATION ANY IMPLIED WARRANTIES OF MERCHANTABILITY, FITNESS FOR A PARTICULAR PURPOSE OR NON-INFRINGEMENT OF THIRD PARTY INTELLECTUAL PROPERTY RIGHTS.

These resources are intended for skilled developers designing with TI products. You are solely responsible for (1) selecting the appropriate TI products for your application, (2) designing, validating and testing your application, and (3) ensuring your application meets applicable standards, and any other safety, security, regulatory or other requirements.

These resources are subject to change without notice. TI grants you permission to use these resources only for development of an application that uses the TI products described in the resource. Other reproduction and display of these resources is prohibited. No license is granted to any other TI intellectual property right or to any third party intellectual property right. TI disclaims responsibility for, and you will fully indemnify TI and its representatives against, any claims, damages, costs, losses, and liabilities arising out of your use of these resources.

TI's products are provided subject to [TI's Terms of Sale](#) or other applicable terms available either on ti.com or provided in conjunction with such TI products. TI's provision of these resources does not expand or otherwise alter TI's applicable warranties or warranty disclaimers for TI products.

TI objects to and rejects any additional or different terms you may have proposed.

Mailing Address: Texas Instruments, Post Office Box 655303, Dallas, Texas 75265
Copyright © 2022, Texas Instruments Incorporated

Looking for pricing, stock, or lifecycle information?

Click below to explore more details on WIN SOURCE:

 [View SN74FB1653PCA](#) on WIN SOURCE

 [Texas Instruments](#) Information

Optimize Your Supply Chain with WIN SOURCE Solutions

-  Global Sourcing Solution
-  Obsolete Management
-  Cost Control Management
-  Shortage Management
-  Alternative Solution
-  Excess Inventory Management