



**THE DATASHEET OF
SN74FB1650PCA**



SN74FB1650

18-BIT TTL/BTL UNIVERSAL STORAGE TRANSCEIVER

SCBS1780 – AUGUST 1992 – REVISED MARCH 2004

- Compatible With IEEE Std 1194.1-1991 (BTL)
- TTL A Port, Backplane Transceiver Logic (BTL) \bar{B} Port
- Open-Collector \bar{B} -Port Outputs Sink 100 mA
- BIAS V_{CC} Minimizes Signal Distortion During Live Insertion or Withdrawal
- High-Impedance State During Power Up and Power Down
- \bar{B} -Port Biasing Network Preconditions the Connector and PC Trace to the BTL High-Level Voltage
- TTL-Input Structures Incorporate Active Clamping to Aid in Line Termination

PCA PACKAGE
(TOP VIEW)

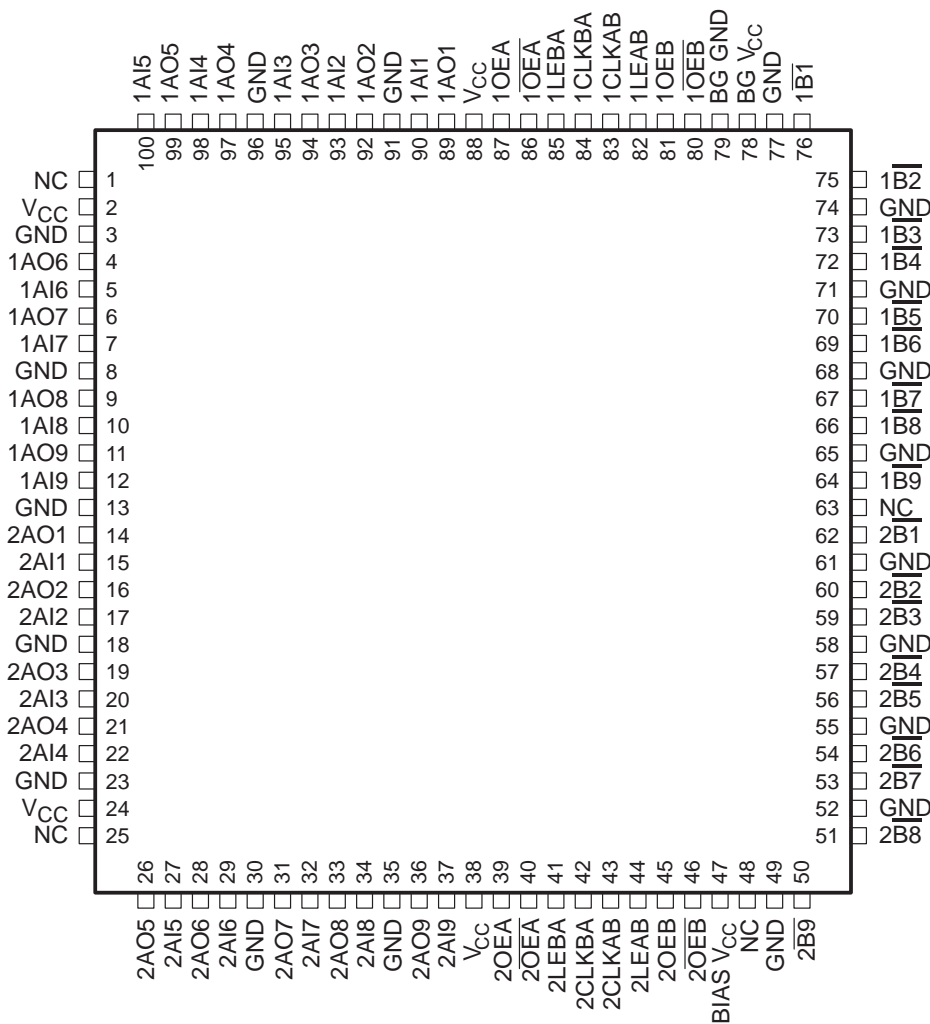

NC – No internal connection



Please be aware that an important notice concerning availability, standard warranty, and use in critical applications of Texas Instruments semiconductor products and disclaimers thereto appears at the end of this data sheet.

PRODUCTION DATA information is current as of publication date. Products conform to specifications per the terms of Texas Instruments standard warranty. Production processing does not necessarily include testing of all parameters.



POST OFFICE BOX 655303 • DALLAS, TEXAS 75265

Copyright © 2004, Texas Instruments Incorporated

SN74FB1650

18-BIT TTL/BTL UNIVERSAL STORAGE TRANSCEIVER

SCBS1780 – AUGUST 1992 – REVISED MARCH 2004

description/ordering information

The SN74FB1650 contains two 9-bit transceivers designed to translate signals between TTL and backplane transceiver-logic (BTL) environments. The device is designed specifically to be compatible with IEEE Std 1194.1-1991.

The \bar{B} port operates at BTL-signal levels. The open-collector \bar{B} ports are specified to sink 100 mA. Two output enables (OEB and \overline{OEB}) are provided for the \bar{B} outputs. When OEB is low, \overline{OEB} is high, or V_{CC} is less than 2.1 V, the \bar{B} port is turned off.

The A port operates at TTL-signal levels. The A outputs reflect the inverse of the data at the \bar{B} port when the A-port output enable (OEA) is high. When OEA is low or when V_{CC} is less than 2.1 V, the A outputs are in the high-impedance state.

BIAS V_{CC} establishes a voltage between 1.62 V and 2.1 V on the BTL outputs when V_{CC} is not connected.

BG V_{CC} and BG GND are the supply inputs for the bias generator.

ORDERING INFORMATION

TA	PACKAGE†		ORDERABLE PART NUMBER	TOP-SIDE MARKING
0°C to 70°C	TQFP – PCA	Tube	SN74FB1650PCA	FB1650

† Package drawings, standard packing quantities, thermal data, symbolization, and PCB design guidelines are available at www.ti.com/sc/package.

Function Tables

TRANSCEIVER

INPUTS				FUNCTION
\overline{OEA}	OEA	OEB	\overline{OEB}	
X	X	H	L	\bar{A} data to B bus
L	H	X	X	\bar{B} data to A bus
L	H	H	L	\bar{A} data to B bus, \bar{B} data to A bus
X	X	L	X	B-bus isolation
X	X	X	H	
H	X	X	X	A-bus isolation
X	L	X	X	

STORAGE MODE

INPUTS		FUNCTION
LE	CLK	
H	X	Transparent
L	↑	Store data
L	L	Storage



functional block diagram

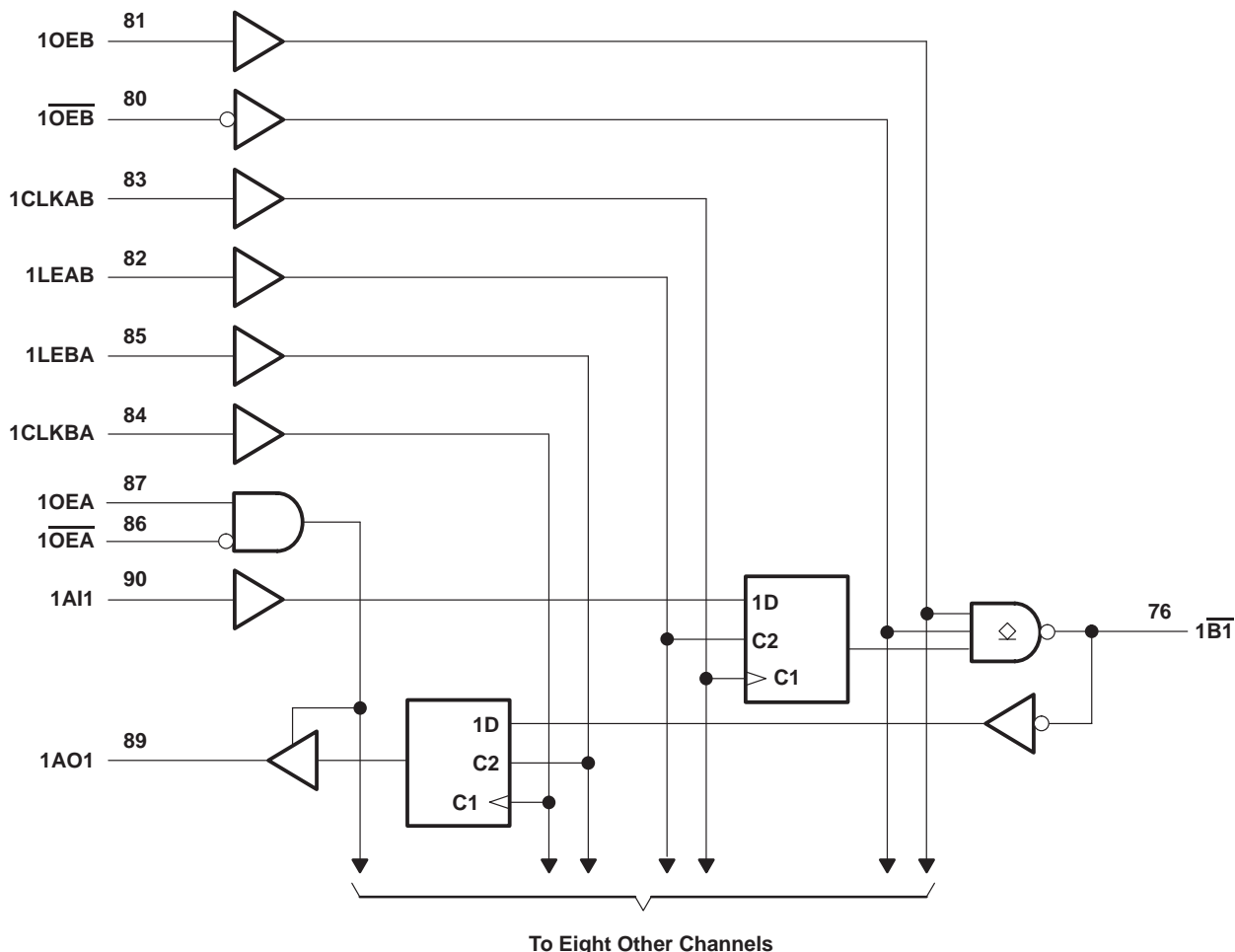

absolute maximum ratings over operating free-air temperature range (unless otherwise noted)†

Supply voltage range, V_{CC} , BIAS V_{CC} , BG V_{CC}	-0.5 V to 7 V
Input voltage range, V_I : Except \bar{B} port	-1.2 V to 7 V
\bar{B} port	-1.2 V to 3.5 V
Voltage range applied to any \bar{B} output in the disabled or power-off state, V_O	-0.5 V to 3.5 V
Voltage range applied to any output in the high state, V_O	-0.5 V to V_{CC}
Input clamp current, I_{IK} : Except \bar{B} port	-40 mA
\bar{B} port	-18 mA
Current applied to any single output in the low state, I_O : A port	48 mA
B port	200 mA
Package thermal impedance, θ_{JA} (see Note 1)	22°C/W
Storage temperature range, T_{stg}	-65°C to 150°C

† Stresses beyond those listed under "absolute maximum ratings" may cause permanent damage to the device. These are stress ratings only, and functional operation of the device at these or any other conditions beyond those indicated under "recommended operating conditions" is not implied. Exposure to absolute-maximum-rated conditions for extended periods may affect device reliability.

NOTE 1: The package thermal impedance is calculated in accordance with JESD 51-7.

SN74FB1650

18-BIT TTL/BTL UNIVERSAL STORAGE TRANSCEIVER

SCBS1780 – AUGUST 1992 – REVISED MARCH 2004

recommended operating conditions (see Note 2)

		MIN	NOM	MAX	UNIT
V_{CC} , BG V_{CC} , BIAS V_{CC}	Supply voltage	4.5	5	5.5	V
V_{IH}	High-level input voltage	\overline{B} port	1.62	2.3	V
		Except \overline{B} port	2		
V_{IL}	Low-level input voltage	\overline{B} port	0.75	1.47	V
		Except \overline{B} port		0.8	
I_{IK}	Input clamp current			-18	mA
I_{OH}	High-level output current			-3	mA
I_{OL}	Low-level output current	A port		24	mA
		\overline{B} port		100	
T_A	Operating free-air temperature	0		70	°C

NOTE 2: To ensure proper device operation, all unused inputs must be terminated as follows: A and control inputs to V_{CC} (5 V) or GND, and B inputs to GND only. Refer to the TI application report, *Implications of Slow or Floating CMOS Inputs*, literature number SCBA004.

electrical characteristics over recommended operating free-air temperature range

PARAMETER		TEST CONDITIONS		MIN	TYP†	MAX	UNIT
V_{IK}	\overline{B} port	$V_{CC} = 4.5$ V,	$I_I = -18$ mA			-1.2	V
	Except \overline{B} port	$V_{CC} = 4.5$ V,	$I_I = -40$ mA			-0.5	
V_{OH}	AO port	$V_{CC} = 4.5$ V,	$I_{OH} = -3$ mA	2.5	3.3		V
V_{OL}	AO port	$V_{CC} = 4.5$ V,	$I_{OL} = 24$ mA		0.35	0.5	V
	\overline{B} port	$V_{CC} = 4.5$ V	$I_{OL} = 80$ mA	0.75	1.1		
			$I_{OL} = 100$ mA		1.15		
I_I	Except \overline{B} port	$V_{CC} = 5.5$ V,	$V_I = 5.5$ V			50	μA
I_{IH}^\ddagger	Except \overline{B} port	$V_{CC} = 5.5$ V,	$V_I = 2.7$ V			50	μA
I_{IL}^\ddagger	Except \overline{B} port	$V_{CC} = 5.5$ V,	$V_I = 0.5$ V			-50	μA
	\overline{B} port	$V_{CC} = 5.5$ V,	$V_I = 0.75$ V			-100	
I_{OZH}	AO port	$V_{CC} = 5.5$ V,	$V_O = 2.7$ V			50	μA
I_{OZL}	AO port	$V_{CC} = 5.5$ V,	$V_O = 0.5$ V			-50	μA
I_{OZPU}	AO port	$V_{CC} = 0$ to 2.1 V,	$V_O = 0.5$ V to 2.7 V			50	μA
I_{OZPD}	AO port	$V_{CC} = 2.1$ V to 0,	$V_O = 0.5$ V to 2.7 V			-50	μA
I_{OH}	\overline{B} port	$V_{CC} = 0$ to 5.5 V,	$V_O = 2.1$ V			100	μA
I_{OS}^\S	A port	$V_{CC} = 5.5$ V,	$V_O = 0$	-30		-150	mA
I_{CC}	A port to \overline{B} port	$V_{CC} = 5.5$ V,	$I_O = 0$			100	mA
	\overline{B} port to A port					120	
C_i	A1 port	$V_I = V_{CC}$ or GND			5.5		pF
	Control inputs				5.5		
C_o	AO ports	$V_O = V_{CC}$ or GND			5.5		pF
C_{io}	\overline{B} port per IEEE Std 1194.1-1991	$V_{CC} = 0$ to 5.5 V				5.5	pF

† All typical values are at $V_{CC} = 5$ V, $T_A = 25^\circ\text{C}$.

‡ For I/O ports, the parameters I_{IH} and I_{IL} include the off-state output current.

§ Not more than one output should be shorted at a time, and the duration of the short circuit should not exceed one second.



SN74FB1650

18-BIT TTL/BTL UNIVERSAL STORAGE TRANSCEIVER

SCBS1780 – AUGUST 1992 – REVISED MARCH 2004

live-insertion specifications over recommended operating free-air temperature range

PARAMETER		TEST CONDITIONS		MIN	MAX	UNIT
I_{CC} (BIAS V_{CC})	$V_{CC} = 0$ to 4.5 V	$V_B = 0$ to 2 V,	V_I (BIAS V_{CC}) = 4.5 V to 5.5 V	450		μA
	$V_{CC} = 4.5$ V to 5.5 V			10		
V_O	\overline{B} port	$V_{CC} = 0,$	V_I (BIAS V_{CC}) = 5 V	1.62	2.1	V
I_O	\overline{B} port	$V_{CC} = 0,$	$V_B = 1$ V,	V_I (BIAS V_{CC}) = 4.5 V to 5.5 V		μA
		$V_{CC} = 0$ to 2.2 V,	OEB = 0 to 5 V	100		
		$V_{CC} = 0$ to 5.5 V,	OEB = 0 to 0.8 V	1		mA

timing requirements over recommended ranges of supply voltage and operating free-air temperature (unless otherwise noted) (see Figure 1)

			$V_{CC} = 5$ V, $T_A = 25^\circ C$		MIN	MAX	UNIT
			MIN	MAX			
f_{clock}	Clock frequency		150			150	MHz
t_w	Pulse duration	CLK or LE	3.3		3.3		ns
t_{su}	Setup time	Data before LE	4.8		4.8		ns
		Data before CLK \uparrow	4.9		4.9		
t_h	Hold time	Data after LE	1.8		1.8		ns
		Data after CLK \uparrow	1.1		1.1		

SN74FB1650

18-BIT TTL/BTL UNIVERSAL STORAGE TRANSCEIVER

SCBS1780 – AUGUST 1992 – REVISED MARCH 2004

switching characteristics over recommended ranges of supply voltage and operating free-air temperature (unless otherwise noted) (see Figure 1)

PARAMETER	FROM (INPUT)	TO (OUTPUT)	$V_{CC} = 5\text{ V}$, $T_A = 25^\circ\text{C}$			MIN	MAX	UNIT
			MIN	TYP	MAX			
f_{max}			150			150		MHz
t_{PLH}	AI	\overline{B}	1.8	3.7	5.3	1.8	6.2	ns
t_{PHL}			2.9	4.4	6	2.9	7.2	
t_{PLH}	LEAB	\overline{B}	2.7	4.2	5.8	2.7	6.4	ns
t_{PHL}			3.5	5	6.5	3.5	7.3	
t_{PLH}	CLKAB	\overline{B}	2.3	3.9	5.5	2.3	6	ns
t_{PHL}			2.9	4.5	6.1	2.9	6.7	
t_{PLH}	\overline{B}	AO	3.5	5.9	7.9	3.5	8.6	ns
t_{PHL}			2.2	3.7	5.3	2.2	5.7	
t_{PLH}	LEBA	AO	1.8	3.2	4.6	1.8	5.1	ns
t_{PHL}			1.7	3	4.4	1.7	4.7	
t_{PLH}	CLKBA	AO	1.8	3.1	4.6	1.8	5.1	ns
t_{PHL}			1.7	3.1	4.6	1.7	4.9	
t_{PLH}	OEB	\overline{B}	2.7	4.6	6.4	2.7	6.7	ns
t_{PHL}			2.9	4.1	5.9	2.9	6.6	
t_{PLH}	\overline{OEB}	\overline{B}	2.6	4.3	6.2	2.6	6.6	ns
t_{PHL}			3.4	4.6	6.4	3.4	7	
t_{PZH}	OEA	AO	1.4	2.9	4.4	1.4	4.9	ns
t_{PZL}			1.4	2.6	4	1.4	4.6	
t_{PHZ}	OEA	AO	1.7	3.4	5.1	1.7	5.8	ns
t_{PLZ}			2.2	3.6	5	2.2	5.5	
t_{PZH}	\overline{OEA}	AO	1.7	3.3	4.7	1.7	5.5	ns
t_{PZL}			1.7	3.1	4.4	1.7	5.1	
t_{PHZ}	\overline{OEA}	AO	1.5	2.9	4.5	1.5	5.1	ns
t_{PLZ}			2	3.1	4.6	2	4.8	
$t_{sk(p)}^\dagger$	Pulse skew, AI to \overline{B} or \overline{B} to AO		1					ns
$t_{sk(o)}^\dagger$	Output skew, AI to \overline{B} or \overline{B} to AO		0.5					ns
t_t Transition time	\overline{B} outputs (1.3 V to 1.8 V)		0.9	1.7	3.1	0.5	4.6	ns
	AO outputs (10% to 90%)		0.5	2	3.6	0.4	4.2	
$t_{(pr)}$	\overline{B} -port input pulse rejection		1			1		ns

[†] Skew values are applicable for through mode only.



PARAMETER MEASUREMENT INFORMATION

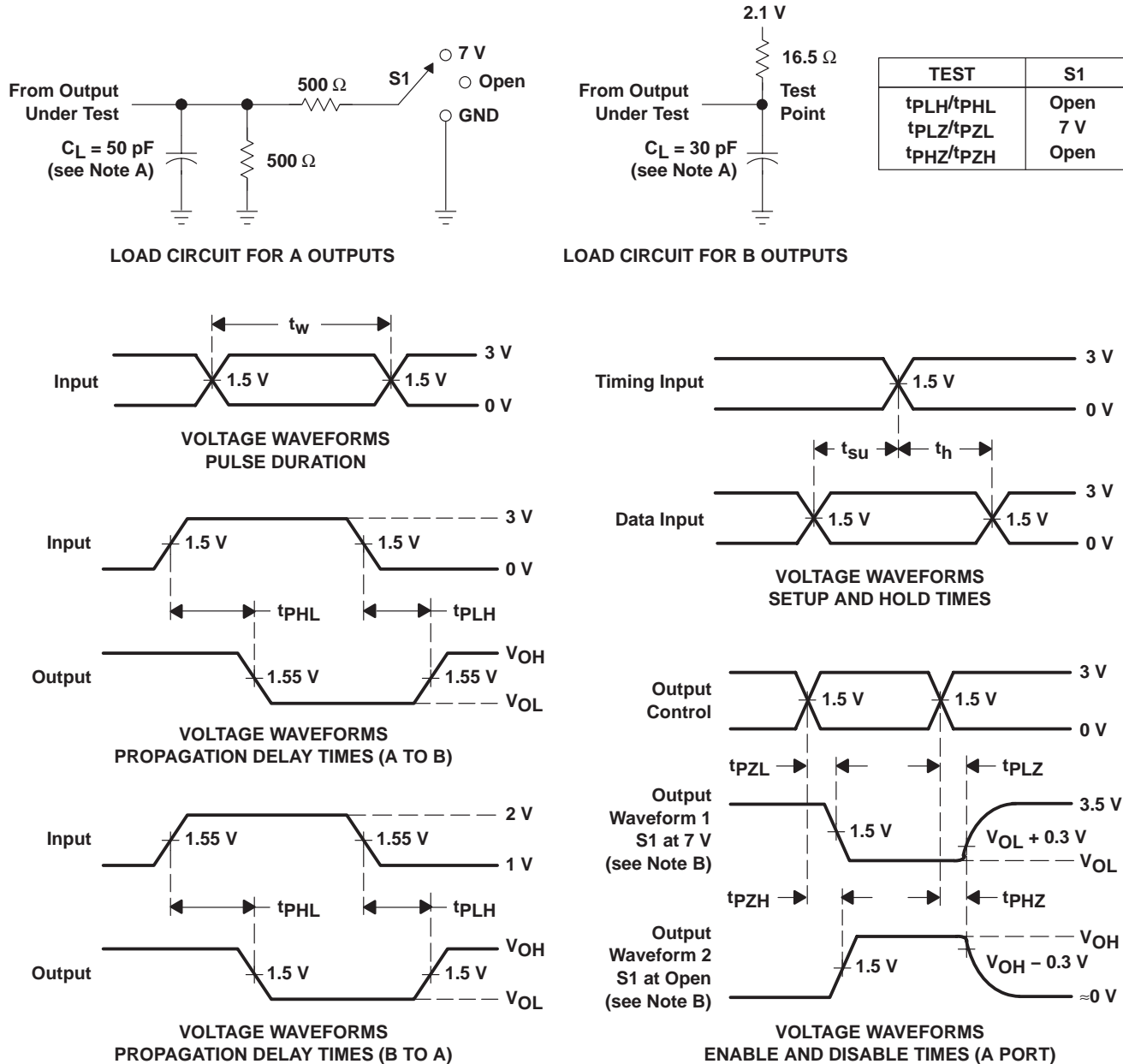

- NOTES: A. C_L includes probe and jig capacitance.
 B. Waveform 1 is for an output with internal conditions such that the output is low, except when disabled by the output control. Waveform 2 is for an output with internal conditions such that the output is high, except when disabled by the output control.
 C. All input pulses are supplied by generators having the following characteristics: TTL inputs: $PRR \leq 10$ MHz, $Z_O = 50 \Omega$, $t_r \leq 2.5$ ns, $t_f \leq 2.5$ ns; BTL inputs: $PRR \leq 10$ MHz, $Z_O = 50 \Omega$, $t_r \leq 2.5$ ns, $t_f \leq 2.5$ ns.
 D. The outputs are measured one at a time, with one transition per measurement.

Figure 1. Load Circuits and Voltage Waveforms

PCA (S-PQFP-G100)

PLASTIC QUAD FLATPACK (DIE DOWN)

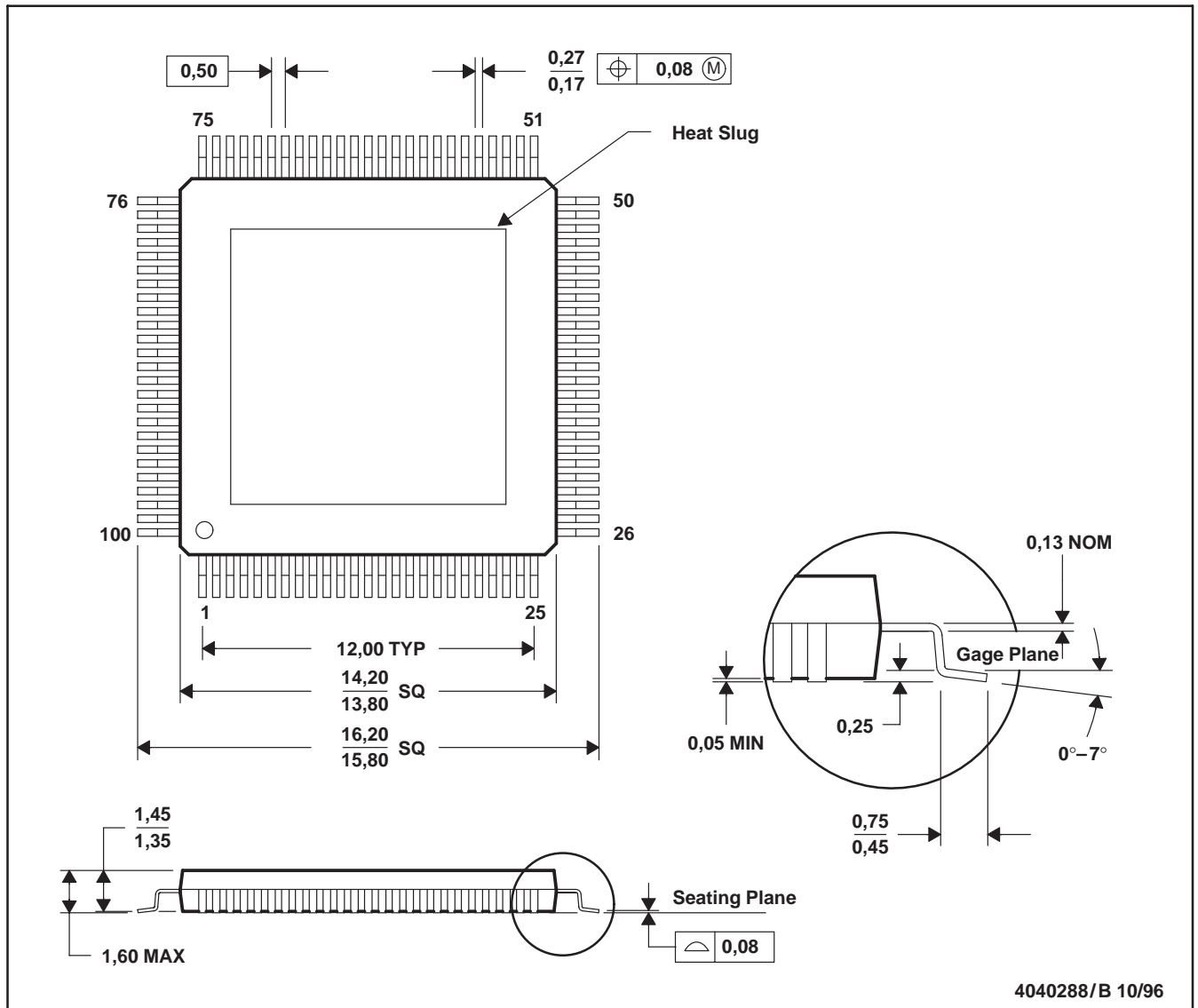

- NOTES: A. All linear dimensions are in millimeters.
 B. This drawing is subject to change without notice.
 C. Thermally enhanced molded plastic package with a heat slug (HSL)
 D. Falls within JEDEC MS-026

IMPORTANT NOTICE

Texas Instruments Incorporated and its subsidiaries (TI) reserve the right to make corrections, modifications, enhancements, improvements, and other changes to its products and services at any time and to discontinue any product or service without notice. Customers should obtain the latest relevant information before placing orders and should verify that such information is current and complete. All products are sold subject to TI's terms and conditions of sale supplied at the time of order acknowledgment.

TI warrants performance of its hardware products to the specifications applicable at the time of sale in accordance with TI's standard warranty. Testing and other quality control techniques are used to the extent TI deems necessary to support this warranty. Except where mandated by government requirements, testing of all parameters of each product is not necessarily performed.

TI assumes no liability for applications assistance or customer product design. Customers are responsible for their products and applications using TI components. To minimize the risks associated with customer products and applications, customers should provide adequate design and operating safeguards.

TI does not warrant or represent that any license, either express or implied, is granted under any TI patent right, copyright, mask work right, or other TI intellectual property right relating to any combination, machine, or process in which TI products or services are used. Information published by TI regarding third-party products or services does not constitute a license from TI to use such products or services or a warranty or endorsement thereof. Use of such information may require a license from a third party under the patents or other intellectual property of the third party, or a license from TI under the patents or other intellectual property of TI.

Reproduction of information in TI data books or data sheets is permissible only if reproduction is without alteration and is accompanied by all associated warranties, conditions, limitations, and notices. Reproduction of this information with alteration is an unfair and deceptive business practice. TI is not responsible or liable for such altered documentation.

Resale of TI products or services with statements different from or beyond the parameters stated by TI for that product or service voids all express and any implied warranties for the associated TI product or service and is an unfair and deceptive business practice. TI is not responsible or liable for any such statements.

Following are URLs where you can obtain information on other Texas Instruments products and application solutions:

Products		Applications	
Amplifiers	amplifier.ti.com	Audio	www.ti.com/audio
Data Converters	dataconverter.ti.com	Automotive	www.ti.com/automotive
DSP	dsp.ti.com	Broadband	www.ti.com/broadband
Interface	interface.ti.com	Digital Control	www.ti.com/digitalcontrol
Logic	logic.ti.com	Military	www.ti.com/military
Power Mgmt	power.ti.com	Optical Networking	www.ti.com/opticalnetwork
Microcontrollers	microcontroller.ti.com	Security	www.ti.com/security
		Telephony	www.ti.com/telephony
		Video & Imaging	www.ti.com/video
		Wireless	www.ti.com/wireless

Mailing Address: Texas Instruments
Post Office Box 655303 Dallas, Texas 75265

Looking for pricing, stock, or lifecycle information?

Click below to explore more details on WIN SOURCE:

 [View SN74FB1650PCA](#) on WIN SOURCE

 [Texas Instruments](#) Information

Optimize Your Supply Chain with WIN SOURCE Solutions

-  Global Sourcing Solution
-  Obsolete Management
-  Cost Control Management
-  Shortage Management
-  Alternative Solution
-  Excess Inventory Management