



**THE DATASHEET OF
SN74CB3Q3305PWRE4**



SN74CB3Q3305 Dual FET Bus Switch

2.5-V or 3.3-V Low-Voltage High-Bandwidth Bus Switch

1 Features

- High-bandwidth data path (up to 500 MHz)¹
- 5-V tolerant I/Os with device powered up or powered down
- Low and flat ON-state resistance (r_{on}) characteristics over operating range ($r_{on} = 3 \Omega$ typical)
- Supports input voltage beyond supply on data I/O ports
 - 0 to 5 V switching with 3.3 V V_{CC}
 - 0 to 3.3 V switching with 2.5 V V_{CC}
- Bidirectional data flow with near-zero propagation delay
- Low input or output capacitance minimizes loading and signal distortion ($C_{io(OFF)} = 3.5$ pF typical)
- Fast switching frequency ($f_{OE} = 20$ MHz maximum)
- Data and control inputs provide undershoot clamp diodes
- Low power consumption ($I_{CC} = 0.25$ mA typical)
- V_{CC} operating range from 2.3 V to 3.6 V
- Data I/Os support 0 to 5 V signaling levels (0.8 V, 1.2 V, 1.5 V, 1.8 V, 2.5 V, 3.3 V, and 5 V)
- Control inputs can be driven by TTL or 5 V/3.3 V CMOS outputs
- I_{off} supports partial-power-down mode operation
- Latch-up performance exceeds 100 mA per JESD 78, Class II

2 Applications

- IP phones: wired and wireless
- Optical modules
- Optical networking: video over fiber and EPON
- Private branch exchange (PBX)
- WiMAX and wireless infrastructure equipment
- USB, differential signal interface
- Bus isolation

3 Description

The SN74CB3Q3305 device is a high-bandwidth FET bus switch using a charge pump to elevate the gate voltage of the pass transistor, providing a low and flat ON-state resistance (r_{on}). The low and flat ON-state resistance allows for minimal propagation delay and supports switching input voltage beyond the supply on the data input/output (I/O) ports. The device also features low data I/O capacitance to minimize capacitive loading and signal distortion on the data bus. Specifically designed to support high-bandwidth applications, the SN74CB3Q3305 device provides an optimized interface solution ideally suited for broadband communications, networking, and data-intensive computing systems.

This device is fully specified for partial-power-down applications using I_{off} . The I_{off} circuitry prevents damaging current backflow through the device when it is powered down. The device has isolation during power off.

To ensure the high-impedance state during power up or power down, OE should be tied to GND through a pulldown resistor; the minimum value of the resistor is determined by the current-sourcing capability of the driver.

Device Information⁽¹⁾

PART NUMBER	PACKAGE	BODY SIZE (NOM)
SN74CB3Q3305	VSSOP (8)	2.00 mm × 3.10 mm
	TSSOP (8)	3.00 mm × 6.10 mm

- (1) For all available packages, see the orderable addendum at the end of the data sheet.

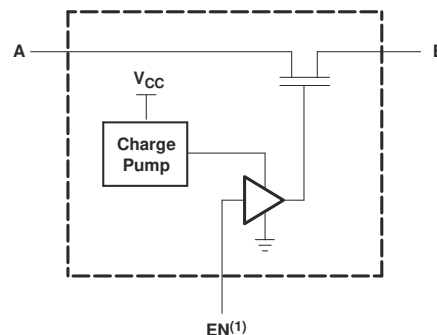

(1) EN is the internal enable signal applied to the switch.

Simplified Schematic, Each FET Switch (SW)

¹ For additional information regarding the performance characteristics of the CB3Q family, refer to the TI application report, *CBT-C, CB3T, and CB3Q Signal-Switch Families*, [SCDA008](#).



Table of Contents

1 Features	1	8.4 Device Functional Modes.....	8
2 Applications	1	9 Application and Implementation	9
3 Description	1	9.1 Application Information.....	9
4 Revision History	2	9.2 Typical Application.....	9
5 Pin Configuration and Functions	3	10 Power Supply Recommendations	10
6 Specifications	4	11 Layout	10
6.1 Absolute Maximum Ratings.....	4	11.1 Layout Guidelines.....	10
6.2 ESD Ratings.....	4	11.2 Layout Example.....	10
6.3 Recommended Operating Conditions ⁽¹⁾	4	12 Device and Documentation Support	11
6.4 Thermal Information.....	5	12.1 Documentation Support.....	11
6.5 Electrical Characteristics.....	5	12.2 Receiving Notification of Documentation Updates..	11
6.6 Switching Characteristics.....	6	12.3 Support Resources.....	11
6.7 Typical Characteristics.....	6	12.4 Trademarks.....	11
7 Parameter Measurement Information	7	12.5 Electrostatic Discharge Caution.....	11
8 Detailed Description	8	12.6 Glossary.....	11
8.1 Overview.....	8	13 Mechanical, Packaging, and Orderable Information	11
8.2 Functional Block Diagram.....	8		
8.3 Feature Description.....	8		

4 Revision History

NOTE: Page numbers for previous revisions may differ from page numbers in the current version.

Changes from Revision C (October 2015) to Revision D (September 2021) Page

- Updated the numbering format for tables, figures, and cross-references throughout the document..... 1
- Updated data sheet to include inclusive terminology..... 1

Changes from Revision B (October 2009) to Revision C (October 2015) Page

- Added *Pin Configuration and Functions* section, *ESD Ratings* table, *Feature Description* section, *Device Functional Modes*, *Application and Implementation* section, *Power Supply Recommendations* section, *Layout* section, *Device and Documentation Support* section, and *Mechanical, Packaging, and Orderable Information* section 1

5 Pin Configuration and Functions

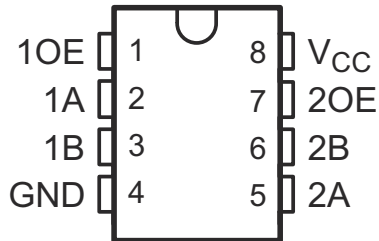

**Figure 5-1. PW Package
8-Pin TSSOP
Top View**

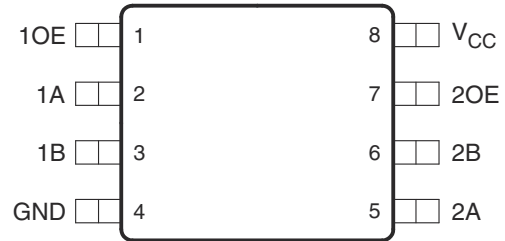

**Figure 5-2. DCU Package
8-Pin VSSOP
Top View**

Table 5-1. Pin Functions

PIN		TYPE ⁽¹⁾	DESCRIPTION
NAME	NO.		
1A	2	I/O	Channel 1 A port
1B	3	I/O	Channel 1 B port
1OE	1	I	Output Enable for switch 1
2A	5	I/O	Channel 2 A port
2B	6	I/O	Channel 2 B port
2OE	7	I	Output Enable for switch 2
GND	4	P	Ground
V _{CC}	8	P	Power supply

(1) I = input, O = output, I/O = input and output, P = power

6 Specifications

6.1 Absolute Maximum Ratings

over operating free-air temperature range (unless otherwise noted)⁽¹⁾

		MIN	MAX	UNIT
V _{CC}	Supply voltage	-0.5	4.6	V
V _{IN}	Control input voltage ^{(2) (3)}	-0.5	7	V
V _{I/O}	Switch I/O voltage ^{(2) (3) (4)}	-0.5	7	V
I _{IK}	Control input clamp current	V _{IN} < 0	-50	mA
I _{I/OK}	I/O port clamp current	V _{I/O} < 0	-50	mA
I _{I/O}	ON-state switch current ⁽⁵⁾		±64	mA
	Continuous current through V _{CC} or GND		±100	mA
θ _{JA}	Package thermal impedance ⁽⁶⁾		88	°C/W
T _J	Junction temperature		150	°C
T _{stg}	Storage temperature	-65	150	°C

(1) Stresses beyond those listed under *Absolute Maximum Ratings* may cause permanent damage to the device. These are stress ratings only, which do not imply functional operation of the device at these or any other conditions beyond those indicated under *Recommended Operating Conditions*. Exposure to absolute-maximum-rated conditions for extended periods may affect device reliability.

(2) All voltages are with respect to ground, unless otherwise specified.

(3) The input and output voltage ratings may be exceeded if the input and output clamp-current ratings are observed.

(4) V_I and V_O are used to denote specific conditions for V_{I/O}.

(5) I_I and I_O are used to denote specific conditions for I_{I/O}.

(6) The package thermal impedance is calculated in accordance with JESD 51-7.

6.2 ESD Ratings

		VALUE	UNIT
V _(ESD)	Electrostatic discharge	Human body model (HBM), per ANSI/ESDA/JEDEC JS-001 ⁽¹⁾	2000
		Charged-device model (CDM), per JEDEC specification JESD22-C101 ⁽²⁾	1000

(1) JEDEC document JEP155 states that 500-V HBM allows safe manufacturing with a standard ESD control process.

(2) JEDEC document JEP157 states that 250-V CDM allows safe manufacturing with a standard ESD control process.

6.3 Recommended Operating Conditions⁽¹⁾

		MIN	MAX	UNIT
V _{CC}	Supply voltage	2.3	3.6	V
V _{IH}	High-level control input voltage	V _{CC} = 2.3 V to 2.7 V	1.7	V
		V _{CC} = 2.7 V to 3.6 V	2	
V _{IL}	Low-level control input voltage	V _{CC} = 2.3 V to 2.7 V	0.7	V
		V _{CC} = 2.7 V to 3.6 V	0.8	
V _{I/O}	Data input/output voltage	0	5.5	V
T _A	Operating free-air temperature	-40	85	°C

(1) All unused control inputs of the device must be held at V_{CC} or GND to ensure proper device operation. Refer to the TI application report, *Implications of Slow or Floating CMOS Inputs*, SCBA004.

6.4 Thermal Information

THERMAL METRIC ⁽¹⁾		SN74CB3Q3305	SN74CB3Q3305	UNIT
		DCU (VSSOP)	PW (TSSOP)	
		8 PINS	8 PINS	
R _{θJA}	Junction-to-ambient thermal resistance	183	190.6	°C/W
R _{θJC(top)}	Junction-to-case (top) thermal resistance	64.2	74.0	°C/W
R _{θJB}	Junction-to-board thermal resistance	62.5	119.4	°C/W
ψ _{JT}	Junction-to-top characterization parameter	4.3	120.0	°C/W
ψ _{JB}	Junction-to-board characterization parameter	62.1	117.7	°C/W
R _{θJC(bot)}	Junction-to-case (bottom) thermal resistance	—	—	°C/W

(1) For more information about traditional and new thermal metrics, see the *Semiconductor and IC Package Thermal Metrics* application report, [SPRA953](#).

6.5 Electrical Characteristics

over recommended operating free-air temperature range (unless otherwise noted)⁽¹⁾

PARAMETER		TEST CONDITIONS		MIN	TYP ⁽²⁾	MAX	UNIT
V _{IK}		V _{CC} = 3.6 V,	I _I = -18 mA			-1.8	V
I _{IN}	Control inputs	V _{CC} = 3.6 V,	V _{IN} = 0 to 5.5 V			±1	μA
I _{OZ} ⁽³⁾		V _{CC} = 3.6 V,	V _O = 0 to 5.5 V, V _I = 0, Switch OFF, V _{IN} = V _{CC} or GND			±1	μA
I _{off}		V _{CC} = 0,	V _O = 0 to 5.5 V, V _I = 0			1	μA
I _{CC}		V _{CC} = 3.6 V,	I _{I/O} = 0, Switch ON or OFF, V _{IN} = V _{CC} or GND		0.25	0.7	mA
ΔI _{CC} ⁽⁴⁾	Control inputs	V _{CC} = 3.6 V, One input at 3 V, Other inputs at V _{CC} or GND				25	μA
I _{CCD} ⁽⁵⁾	Per control input	V _{CC} = 3.6 V,	A and B ports open, Control input switching at 50% duty cycle		0.040	0.045	mA/ MHz
C _{in}	Control inputs	V _{CC} = 3.3 V,	V _{IN} = 5.5 V, 3.3 V, or 0		2.5	3.5	pF
C _{io(OFF)}		V _{CC} = 3.3 V,	Switch OFF, V _{IN} = V _{CC} or GND, V _{I/O} = 5.5 V, 3.3 V, or 0		3.5	5	pF
C _{io(ON)}		V _{CC} = 3.3 V,	Switch ON, V _{IN} = V _{CC} or GND, V _{I/O} = 5.5 V, 3.3 V, or 0		8	10.5	pF
r _{on} ⁽⁶⁾	V _{CC} = 2.3 V, TYP at V _{CC} = 2.5 V	V _I = 0, I _O = 30 mA			3	8	Ω
		V _I = 1.7 V, I _O = -15 mA			3.5	9	
	V _{CC} = 3 V	V _I = 0, I _O = 30 mA			3	6	
		V _I = 2.4 V, I _O = -15 mA			3.5	8	

(1) V_{IN} and I_{IN} refer to control inputs. V_I, V_O, I_I, and I_O refer to data pins.

(2) All typical values are at V_{CC} = 3.3 V (unless otherwise noted), T_A = 25°C.

(3) For I/O ports, the parameter I_{OZ} includes the input leakage current.

(4) This is the increase in supply current for each input that is at the specified TTL voltage level, rather than V_{CC} or GND.

(5) This parameter specifies the dynamic power-supply current associated with the operating frequency of a single control input (see [Figure 9-2](#)).

(6) Measured by the voltage drop between the A and B terminals at the indicated current through the switch. ON-state resistance is determined by the lower of the voltages of the two (A or B) terminals.

6.6 Switching Characteristics

over recommended operating free-air temperature range (unless otherwise noted) (see Figure 7-1)

PARAMETER	FROM (INPUT)	TO (OUTPUT)	V _{CC}	MIN	MAX	UNIT
f _{OE} ⁽¹⁾	OE	A or B	V _{CC} = 2.5 V ± 0.2 V		10	MHz
			V _{CC} = 3.3 V ± 0.3 V		20	
t _{pd} ⁽²⁾	A or B	B or A	V _{CC} = 2.5 V ± 0.2 V		0.09	ns
			V _{CC} = 3.3 V ± 0.3 V		0.15	
t _{en}	OE	A or B	V _{CC} = 2.5 V ± 0.2 V	1	5	ns
			V _{CC} = 3.3 V ± 0.3 V	1	4.5	
t _{dis}	OE	A or B	V _{CC} = 2.5 V ± 0.2 V	1	4.5	ns
			V _{CC} = 3.3 V ± 0.3 V	1	5	

- (1) Maximum switching frequency for control input (V_O > V_{CC}, V_I = 5 V, R_L ≥ 1 MΩ, C_L = 0).
- (2) The propagation delay is the calculated RC time constant of the typical ON-state resistance of the switch and the specified load capacitance, when driven by an ideal voltage source (zero output impedance).

6.7 Typical Characteristics

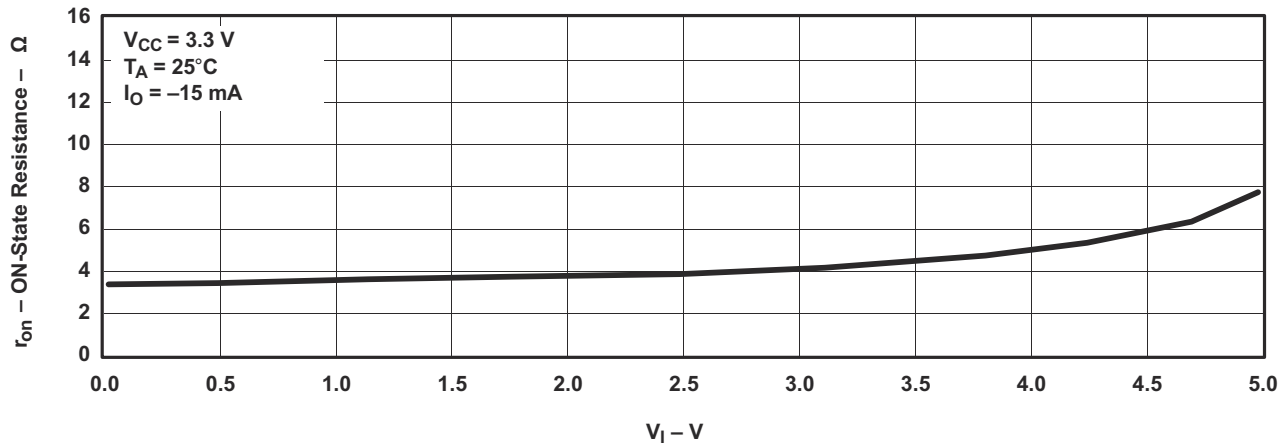
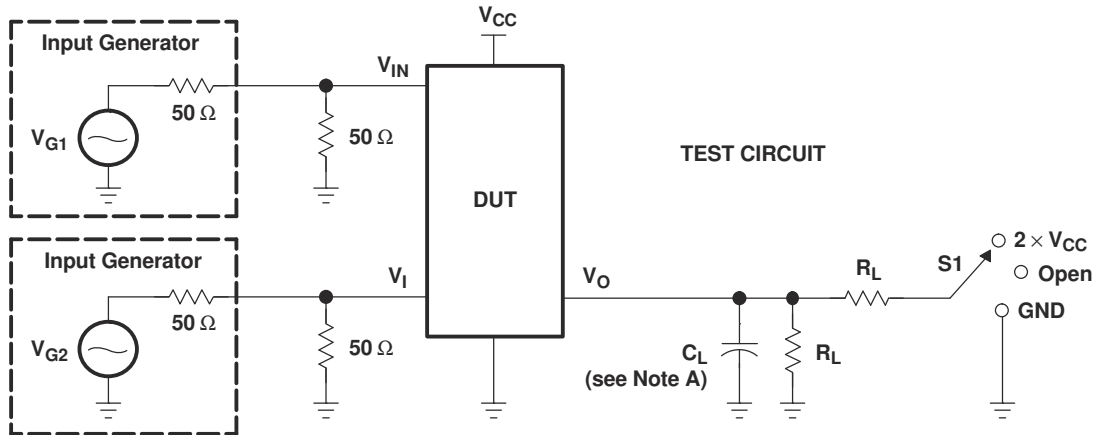
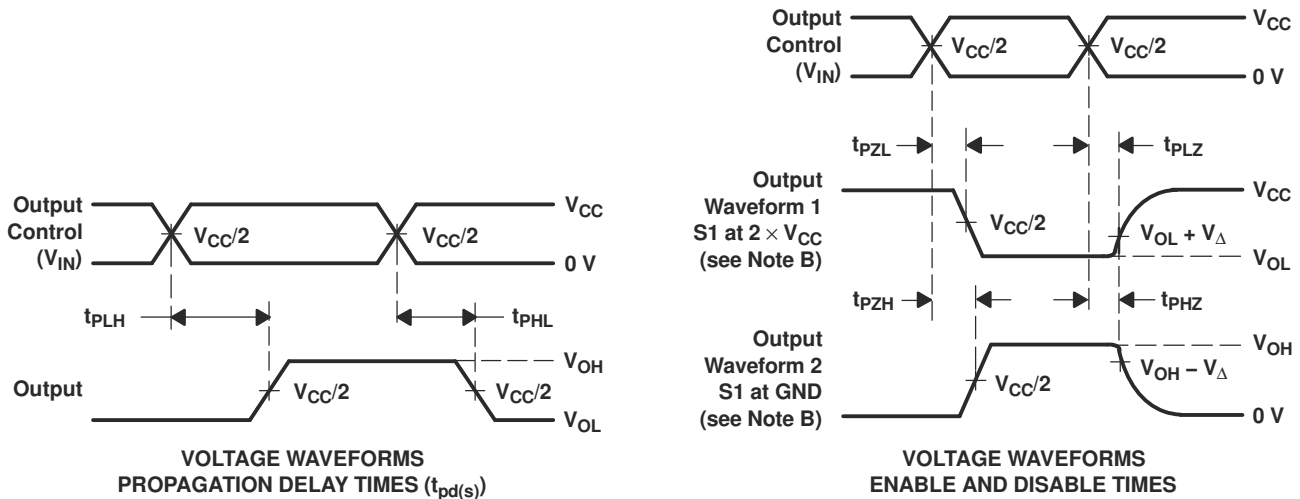

Figure 6-1. Typical r_{on} vs V_I

7 Parameter Measurement Information



TEST	V _{CC}	S1	R _L	V _I	C _L	V _Δ
t _{pd(s)}	2.5 V ± 0.2 V	Open	500 Ω	V _{CC} or GND	30 pF	
	3.3 V ± 0.3 V	Open	500 Ω	V _{CC} or GND	50 pF	
t _{PLZ} /t _{PZL}	2.5 V ± 0.2 V	2 × V _{CC}	500 Ω	GND	30 pF	0.15 V
	3.3 V ± 0.3 V	2 × V _{CC}	500 Ω	GND	50 pF	0.3 V
t _{PHZ} /t _{PZH}	2.5 V ± 0.2 V	GND	500 Ω	V _{CC}	30 pF	0.15 V
	3.3 V ± 0.3 V	GND	500 Ω	V _{CC}	50 pF	0.3 V



- NOTES:
- C_L includes probe and jig capacitance.
 - Waveform 1 is for an output with internal conditions such that the output is low, except when disabled by the output control. Waveform 2 is for an output with internal conditions such that the output is high, except when disabled by the output control.
 - All input pulses are supplied by generators having the following characteristics: PRR ≤ 10 MHz, Z_O = 50 Ω, t_r ≤ 2.5 ns, t_f ≤ 2.5 ns.
 - The outputs are measured one at a time, with one transition per measurement.
 - t_{PLZ} and t_{PHZ} are the same as t_{dis}.
 - t_{PZL} and t_{PZH} are the same as t_{en}.
 - t_{PLH} and t_{PHL} are the same as t_{pd(s)}. The t_{pd} propagation delay is the calculated RC time constant of the typical ON-state resistance of the switch and the specified load capacitance, when driven by an ideal voltage source (zero output impedance).
 - All parameters and waveforms are not applicable to all devices.

Figure 7-1. Test Circuit and Voltage Waveforms

8 Detailed Description

8.1 Overview

The SN74CB3Q3305 device is organized as two 1-bit switches with separate output-enable (1OE and 2OE) inputs. It can be used as two 1-bit bus switches or as one 2-bit bus switch. When OE is high, the associated 1-bit bus switch is ON and the A port is connected to the B port, allowing bidirectional data flow between ports. When OE is low, the associated 1-bit bus switch is OFF and a high-impedance state exists between the A and B ports.

8.2 Functional Block Diagram

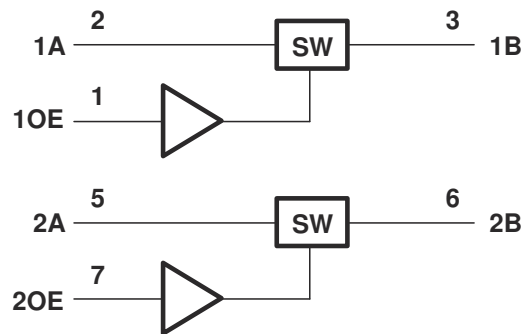

Figure 8-1. Logic Diagram (Positive Logic)

8.3 Feature Description

The device supports High-Bandwidth data path up to 500 MHz. The I/O ports are 5 V tolerant when powered up or powered down due to I_{OFF} . The charge pump creates low and flat ON-state resistance characteristics over the whole operating temperature range.

Switching input voltage beyond the supply is supported on data I/O ports: 0 V to 5 V with 3.3 V V_{CC} or 0 V to 3.3 V with 2.5 V V_{CC} .

The data flow is bidirectional with near-zero propagation delay. Reduced input/output capacitance for higher speed applications. OE can be toggled at the high speeds of 20 MHz for fast switching applications.

8.4 Device Functional Modes

Table 8-1 lists the functional modes of the SN74CB3Q3305.

Table 8-1. Function Table (Each Bus Switch)

INPUT OE	INPUT/OUTPUT A	FUNCTION
H	B	A port = B port
L	Z	Disconnect

9 Application and Implementation

Note

Information in the following applications sections is not part of the TI component specification, and TI does not warrant its accuracy or completeness. TI's customers are responsible for determining suitability of components for their purposes, as well as validating and testing their design implementation to confirm system functionality.

9.1 Application Information

Figure 9-1 shows that the SN74CB3Q3305 can be used as bidirectional switch. The controller operates at 5 V and the peripheral can accept 5 V. Even with a V_{CC} of 3 V on the SN74CB3Q3305, the two ports can be connected to pass the 5 V signal. The controller uses the OE pin control the switch. This is a very generic example and could apply to many situations. For applications that require only 1 bit (for example, one channel), tie the unused OE low and tie the unused ports A and B to either high or low (not shown).

9.2 Typical Application

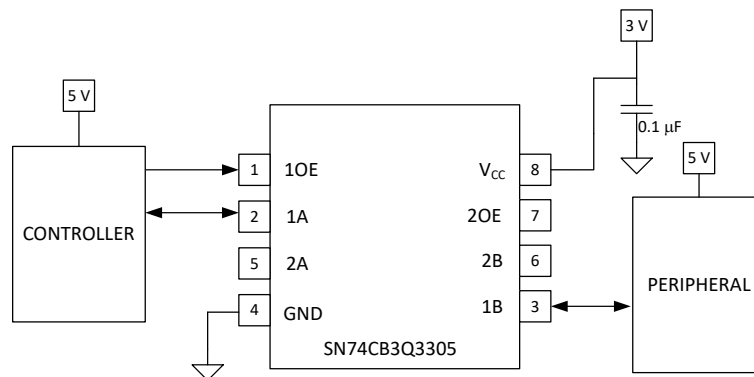

Figure 9-1. Typical Application of the SN74CB3Q3305

9.2.1 Design Requirements

- Recommended Input Conditions:
 - For specified high and low levels, see V_{IH} and V_{IL} in [Section 6.3](#).
 - Inputs and outputs are overvoltage tolerant allowing them to go as high as 5.5 V at any valid V_{CC} .
- Absolute Maximum Conditions:
 - I/O currents should not exceed ± 64 mA per channel.
 - Continuous current through GND or V_{CC} should not exceed ± 100 mA.
- Frequency Selection Criterion:
 - Maximum frequency tested is 500 MHz.
 - Added trace resistance/capacitance can reduce maximum frequency capability; use layout practices as directed in [Section 11](#).

9.2.2 Detailed Design Procedure

The 0.1 μ F capacitor should be placed as close as possible to the device.

9.2.3 Application Curve

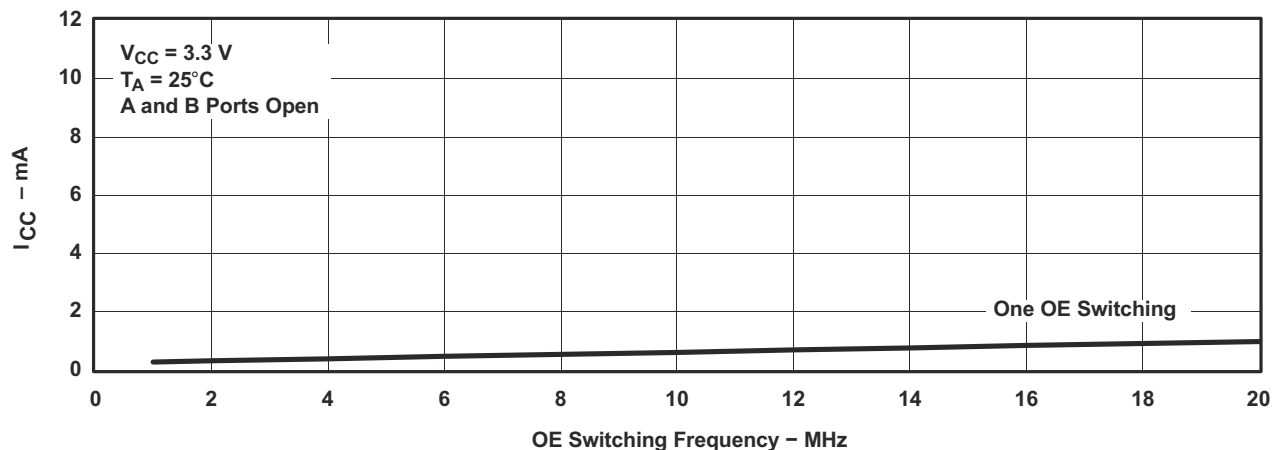

Figure 9-2. Typical I_{CC} vs OE Switching Frequency

10 Power Supply Recommendations

The power supply can be any voltage between the minimum and maximum supply voltage rating listed in Section 6.1 table.

Each V_{CC} terminal should have a good bypass capacitor to prevent power disturbance. For devices with a single supply, a 0.1 μF bypass capacitor is recommended. If multiple pins are labeled V_{CC} , then a 0.01 μF or 0.022 μF capacitor is recommended for each V_{CC} because the V_{CC} pins are tied together internally. For devices with dual-supply pins operating at different voltages, for example V_{CC} and V_{DD} , a 0.1 μF bypass capacitor is recommended for each supply pin. To reject different frequencies of noise, use multiple bypass capacitors in parallel. Capacitors with values of 0.1 μF and 1 μF are commonly used in parallel. The bypass capacitor should be installed as close to the power terminal as possible for best results.

11 Layout

11.1 Layout Guidelines

Reflections and matching are closely related to the loop antenna theory but are different enough to be discussed separately from the theory. When a PCB trace turns a corner at a 90° angle, a reflection can occur. A reflection occurs primarily because of the change of width of the trace. At the apex of the turn, the trace width increases to 1.414 times the width. This increase upsets the transmission-line characteristics, especially the distributed capacitance and self-inductance of the trace which results in the reflection. Not all PCB traces can be straight and therefore some traces must turn corners. Figure 11-1 shows progressively better techniques of rounding corners. Only the last example (BEST) maintains constant trace width and minimizes reflections.

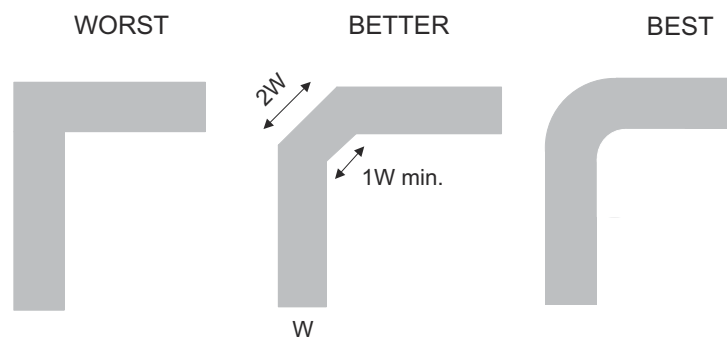

Figure 11-1. Trace Example

12 Device and Documentation Support

12.1 Documentation Support

12.1.1 Related Documentation

For related documentation see the following:

- Texas Instruments, [CBT-C, CB3T, and CB3Q Signal-Switch Families application report](#)
- Texas Instruments, [Implications of Slow or Floating CMOS Inputs application report](#)
- Texas Instruments, [Selecting the Right Texas Instruments Signal Switch application report](#)

12.2 Receiving Notification of Documentation Updates

To receive notification of documentation updates, navigate to the device product folder on [ti.com](#). Click on *Subscribe to updates* to register and receive a weekly digest of any product information that has changed. For change details, review the revision history included in any revised document.

12.3 Support Resources

[TI E2E™ support forums](#) are an engineer's go-to source for fast, verified answers and design help — straight from the experts. Search existing answers or ask your own question to get the quick design help you need.

Linked content is provided "AS IS" by the respective contributors. They do not constitute TI specifications and do not necessarily reflect TI's views; see TI's [Terms of Use](#).

12.4 Trademarks

TI E2E™ is a trademark of Texas Instruments.

All trademarks are the property of their respective owners.

12.5 Electrostatic Discharge Caution



This integrated circuit can be damaged by ESD. Texas Instruments recommends that all integrated circuits be handled with appropriate precautions. Failure to observe proper handling and installation procedures can cause damage.

ESD damage can range from subtle performance degradation to complete device failure. Precision integrated circuits may be more susceptible to damage because very small parametric changes could cause the device not to meet its published specifications.

12.6 Glossary

[TI Glossary](#) This glossary lists and explains terms, acronyms, and definitions.

13 Mechanical, Packaging, and Orderable Information

The following pages include mechanical, packaging, and orderable information. This information is the most current data available for the designated devices. This data is subject to change without notice and revision of this document. For browser-based versions of this data sheet, refer to the left-hand navigation.

PACKAGING INFORMATION

Orderable Device	Status (1)	Package Type	Package Drawing	Pins	Package Qty	Eco Plan (2)	Lead finish/ Ball material (6)	MSL Peak Temp (3)	Op Temp (°C)	Device Marking (4/5)	Samples
74CB3Q3305DCURG4	ACTIVE	VSSOP	DCU	8	3000	RoHS & Green	NIPDAU	Level-1-260C-UNLIM	-40 to 85	GARR	Samples
SN74CB3Q3305DCUR	ACTIVE	VSSOP	DCU	8	3000	RoHS & Green	NIPDAU SN	Level-1-260C-UNLIM	-40 to 85	(GARQ, GARR)	Samples
SN74CB3Q3305PW	LIFEBUY	TSSOP	PW	8	150	RoHS & Green	NIPDAU	Level-1-260C-UNLIM	-40 to 85	BU305	
SN74CB3Q3305PWG4	LIFEBUY	TSSOP	PW	8	150	RoHS & Green	NIPDAU	Level-1-260C-UNLIM	-40 to 85	BU305	
SN74CB3Q3305PWR	ACTIVE	TSSOP	PW	8	2000	RoHS & Green	NIPDAU SN	Level-1-260C-UNLIM	-40 to 85	BU305	Samples
SN74CB3Q3305PWRE4	ACTIVE	TSSOP	PW	8	2000	RoHS & Green	NIPDAU	Level-1-260C-UNLIM	-40 to 85	BU305	Samples
SN74CB3Q3305PWRG4	ACTIVE	TSSOP	PW	8	2000	RoHS & Green	NIPDAU	Level-1-260C-UNLIM	-40 to 85	BU305	Samples

(1) The marketing status values are defined as follows:

ACTIVE: Product device recommended for new designs.

LIFEBUY: TI has announced that the device will be discontinued, and a lifetime-buy period is in effect.

NRND: Not recommended for new designs. Device is in production to support existing customers, but TI does not recommend using this part in a new design.

PREVIEW: Device has been announced but is not in production. Samples may or may not be available.

OBSOLETE: TI has discontinued the production of the device.

(2) **RoHS:** TI defines "RoHS" to mean semiconductor products that are compliant with the current EU RoHS requirements for all 10 RoHS substances, including the requirement that RoHS substance do not exceed 0.1% by weight in homogeneous materials. Where designed to be soldered at high temperatures, "RoHS" products are suitable for use in specified lead-free processes. TI may reference these types of products as "Pb-Free".

RoHS Exempt: TI defines "RoHS Exempt" to mean products that contain lead but are compliant with EU RoHS pursuant to a specific EU RoHS exemption.

Green: TI defines "Green" to mean the content of Chlorine (Cl) and Bromine (Br) based flame retardants meet JS709B low halogen requirements of <=1000ppm threshold. Antimony trioxide based flame retardants must also meet the <=1000ppm threshold requirement.

(3) MSL, Peak Temp. - The Moisture Sensitivity Level rating according to the JEDEC industry standard classifications, and peak solder temperature.

(4) There may be additional marking, which relates to the logo, the lot trace code information, or the environmental category on the device.

(5) Multiple Device Markings will be inside parentheses. Only one Device Marking contained in parentheses and separated by a "~" will appear on a device. If a line is indented then it is a continuation of the previous line and the two combined represent the entire Device Marking for that device.

(6) Lead finish/Ball material - Orderable Devices may have multiple material finish options. Finish options are separated by a vertical ruled line. Lead finish/Ball material values may wrap to two lines if the finish value exceeds the maximum column width.

Important Information and Disclaimer: The information provided on this page represents TI's knowledge and belief as of the date that it is provided. TI bases its knowledge and belief on information provided by third parties, and makes no representation or warranty as to the accuracy of such information. Efforts are underway to better integrate information from third parties. TI has taken and continues to take reasonable steps to provide representative and accurate information but may not have conducted destructive testing or chemical analysis on incoming materials and chemicals. TI and TI suppliers consider certain information to be proprietary, and thus CAS numbers and other limited information may not be available for release.

In no event shall TI's liability arising out of such information exceed the total purchase price of the TI part(s) at issue in this document sold by TI to Customer on an annual basis.

TAPE AND REEL INFORMATION

QUADRANT ASSIGNMENTS FOR PIN 1 ORIENTATION IN TAPE

*All dimensions are nominal

Device	Package Type	Package Drawing	Pins	SPQ	Reel Diameter (mm)	Reel Width W1 (mm)	A0 (mm)	B0 (mm)	K0 (mm)	P1 (mm)	W (mm)	Pin1 Quadrant
74CB3Q3305DCURG4	VSSOP	DCU	8	3000	180.0	8.4	2.25	3.35	1.05	4.0	8.0	Q3
SN74CB3Q3305DCUR	VSSOP	DCU	8	3000	178.0	9.0	2.25	3.35	1.05	4.0	8.0	Q3
SN74CB3Q3305PWR	TSSOP	PW	8	2000	330.0	12.4	7.0	3.6	1.6	8.0	12.0	Q1
SN74CB3Q3305PWRG4	TSSOP	PW	8	2000	330.0	12.4	7.0	3.6	1.6	8.0	12.0	Q1

TAPE AND REEL BOX DIMENSIONS



*All dimensions are nominal

Device	Package Type	Package Drawing	Pins	SPQ	Length (mm)	Width (mm)	Height (mm)
74CB3Q3305DCURG4	VSSOP	DCU	8	3000	202.0	201.0	28.0
SN74CB3Q3305DCUR	VSSOP	DCU	8	3000	180.0	180.0	18.0
SN74CB3Q3305PWR	TSSOP	PW	8	2000	367.0	367.0	35.0
SN74CB3Q3305PWRG4	TSSOP	PW	8	2000	367.0	367.0	35.0

TUBE

*All dimensions are nominal

Device	Package Name	Package Type	Pins	SPQ	L (mm)	W (mm)	T (μm)	B (mm)
SN74CB3Q3305PW	PW	TSSOP	8	150	530	10.2	3600	3.5
SN74CB3Q3305PWG4	PW	TSSOP	8	150	530	10.2	3600	3.5

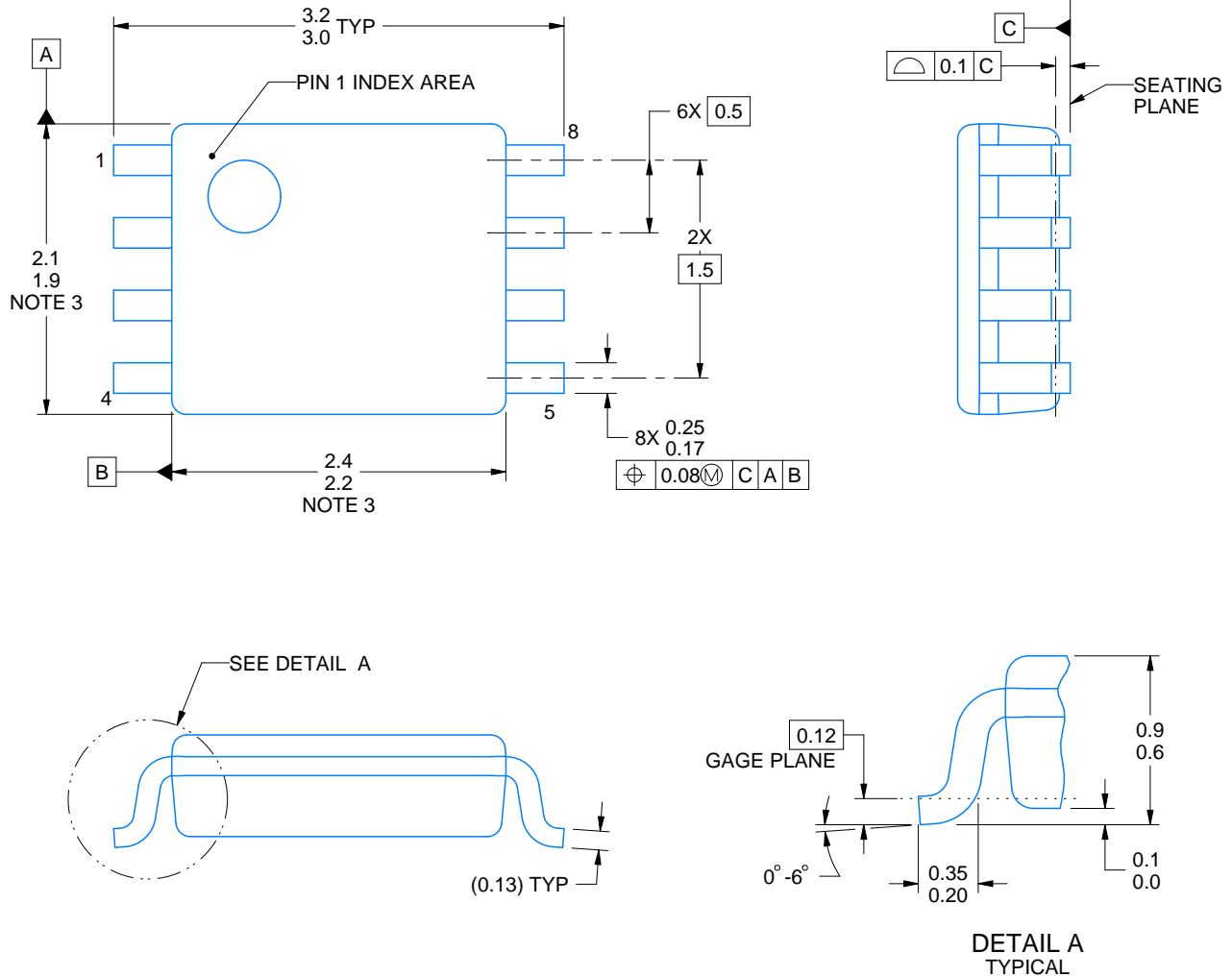

4225266/A 09/2014

NOTES:

1. All linear dimensions are in millimeters. Any dimensions in parenthesis are for reference only. Dimensioning and tolerancing per ASME Y14.5M.
2. This drawing is subject to change without notice.
3. This dimension does not include mold flash, protrusions, or gate burrs. Mold flash, protrusions, or gate burrs shall not exceed 0.15 mm per side.
4. Reference JEDEC registration MO-187 variation CA.

EXAMPLE BOARD LAYOUT

DCU0008A

VSSOP - 0.9 mm max height

SMALL OUTLINE PACKAGE

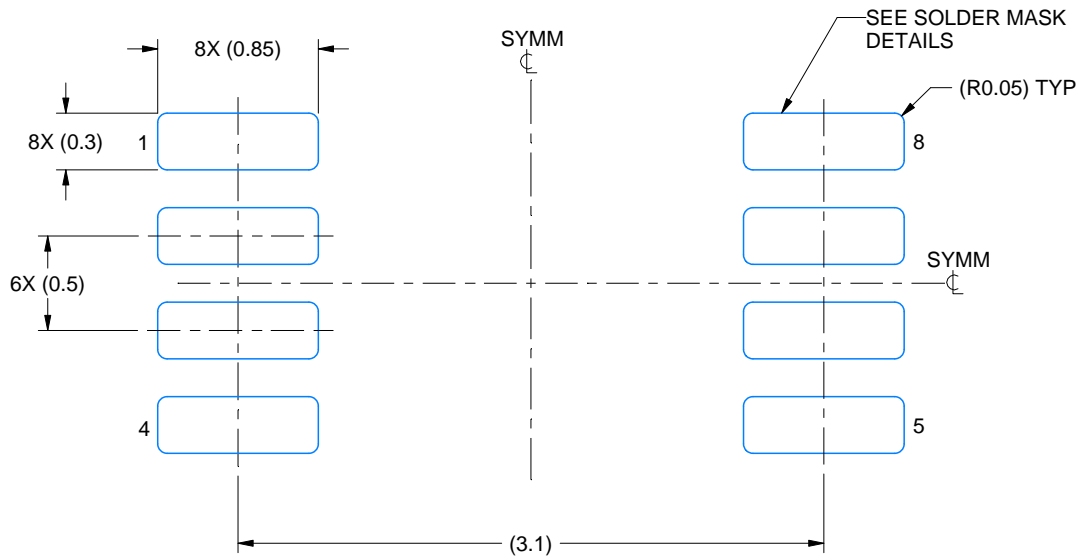

LAND PATTERN EXAMPLE
EXPOSED METAL SHOWN
SCALE: 25X

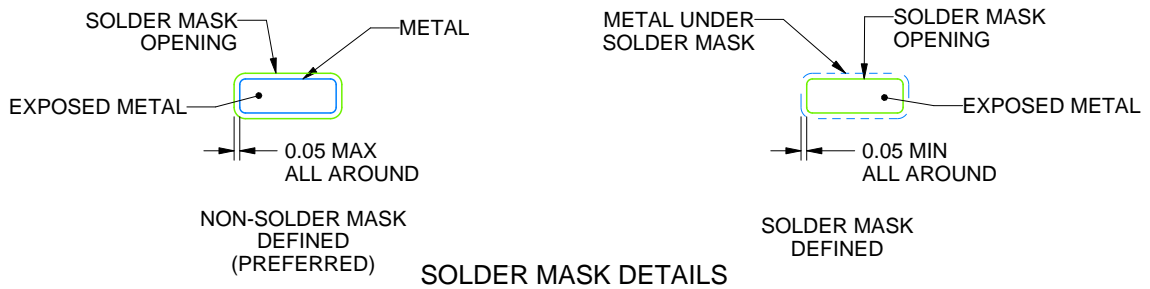

4225266/A 09/2014

NOTES: (continued)

- 5. Publication IPC-7351 may have alternate designs.
- 6. Solder mask tolerances between and around signal pads can vary based on board fabrication site.

EXAMPLE STENCIL DESIGN

DCU0008A

VSSOP - 0.9 mm max height

SMALL OUTLINE PACKAGE

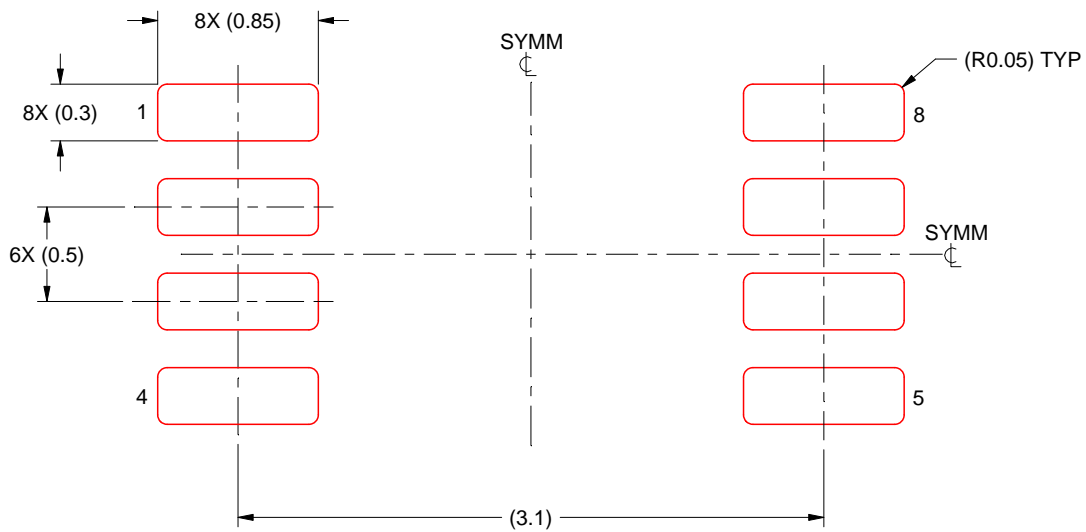

SOLDER PASTE EXAMPLE
BASED ON 0.125 mm THICK STENCIL
SCALE: 25X

4225266/A 09/2014

NOTES: (continued)

7. Laser cutting apertures with trapezoidal walls and rounded corners may offer better paste release. IPC-7525 may have alternate design recommendations.
8. Board assembly site may have different recommendations for stencil design.

PW0008A



PACKAGE OUTLINE
TSSOP - 1.2 mm max height

SMALL OUTLINE PACKAGE



4221848/A 02/2015

NOTES:

- All linear dimensions are in millimeters. Any dimensions in parenthesis are for reference only. Dimensioning and tolerancing per ASME Y14.5M.
- This drawing is subject to change without notice.
- This dimension does not include mold flash, protrusions, or gate burrs. Mold flash, protrusions, or gate burrs shall not exceed 0.15 mm per side.
- This dimension does not include interlead flash. Interlead flash shall not exceed 0.25 mm per side.
- Reference JEDEC registration MO-153, variation AA.

EXAMPLE BOARD LAYOUT

PW0008A

TSSOP - 1.2 mm max height

SMALL OUTLINE PACKAGE



LAND PATTERN EXAMPLE
SCALE:10X



SOLDER MASK DETAILS
NOT TO SCALE

4221848/A 02/2015

NOTES: (continued)

- 6. Publication IPC-7351 may have alternate designs.
- 7. Solder mask tolerances between and around signal pads can vary based on board fabrication site.

EXAMPLE STENCIL DESIGN

PW0008A

TSSOP - 1.2 mm max height

SMALL OUTLINE PACKAGE



SOLDER PASTE EXAMPLE
BASED ON 0.125 mm THICK STENCIL
SCALE:10X

4221848/A 02/2015

NOTES: (continued)

8. Laser cutting apertures with trapezoidal walls and rounded corners may offer better paste release. IPC-7525 may have alternate design recommendations.
9. Board assembly site may have different recommendations for stencil design.

IMPORTANT NOTICE AND DISCLAIMER

TI PROVIDES TECHNICAL AND RELIABILITY DATA (INCLUDING DATA SHEETS), DESIGN RESOURCES (INCLUDING REFERENCE DESIGNS), APPLICATION OR OTHER DESIGN ADVICE, WEB TOOLS, SAFETY INFORMATION, AND OTHER RESOURCES "AS IS" AND WITH ALL FAULTS, AND DISCLAIMS ALL WARRANTIES, EXPRESS AND IMPLIED, INCLUDING WITHOUT LIMITATION ANY IMPLIED WARRANTIES OF MERCHANTABILITY, FITNESS FOR A PARTICULAR PURPOSE OR NON-INFRINGEMENT OF THIRD PARTY INTELLECTUAL PROPERTY RIGHTS.

These resources are intended for skilled developers designing with TI products. You are solely responsible for (1) selecting the appropriate TI products for your application, (2) designing, validating and testing your application, and (3) ensuring your application meets applicable standards, and any other safety, security, regulatory or other requirements.

These resources are subject to change without notice. TI grants you permission to use these resources only for development of an application that uses the TI products described in the resource. Other reproduction and display of these resources is prohibited. No license is granted to any other TI intellectual property right or to any third party intellectual property right. TI disclaims responsibility for, and you will fully indemnify TI and its representatives against, any claims, damages, costs, losses, and liabilities arising out of your use of these resources.

TI's products are provided subject to [TI's Terms of Sale](#) or other applicable terms available either on [ti.com](https://www.ti.com) or provided in conjunction with such TI products. TI's provision of these resources does not expand or otherwise alter TI's applicable warranties or warranty disclaimers for TI products.

TI objects to and rejects any additional or different terms you may have proposed.

Mailing Address: Texas Instruments, Post Office Box 655303, Dallas, Texas 75265
Copyright © 2024, Texas Instruments Incorporated

Looking for pricing, stock, or lifecycle information?

Click below to explore more details on WIN SOURCE:

 [View SN74CB3Q3305PWRE4 on WIN SOURCE](#)

 [Texas Instruments](#) Information

Optimize Your Supply Chain with WIN SOURCE Solutions

-  Global Sourcing Solution
-  Obsolete Management
-  Cost Control Management
-  Shortage Management
-  Alternative Solution
-  Excess Inventory Management