



**THE DATASHEET OF  
SN74AHC374NSR**





## Table of Contents

<b>1</b>	<b>Features</b> .....	<b>1</b>	<b>8</b>	<b>Parameter Measurement Information</b> .....	<b>9</b>
<b>2</b>	<b>Applications</b> .....	<b>1</b>	<b>9</b>	<b>Detailed Description</b> .....	<b>10</b>
<b>3</b>	<b>Description</b> .....	<b>1</b>	9.1	Overview .....	10
<b>4</b>	<b>Simplified Schematic</b> .....	<b>1</b>	9.2	Functional Block Diagram .....	10
<b>5</b>	<b>Revision History</b> .....	<b>2</b>	9.3	Feature Description .....	10
<b>6</b>	<b>Pin Configuration and Functions</b> .....	<b>3</b>	9.4	Device Functional Modes .....	10
<b>7</b>	<b>Specifications</b> .....	<b>4</b>	<b>10</b>	<b>Application and Implementation</b> .....	<b>11</b>
7.1	Absolute Maximum Ratings .....	4	10.1	Application Information .....	11
7.2	ESD Ratings .....	4	10.2	Typical Application .....	11
7.3	Recommended Operating Conditions .....	4	<b>11</b>	<b>Power Supply Recommendations</b> .....	<b>12</b>
7.4	Thermal Information .....	5	<b>12</b>	<b>Layout</b> .....	<b>13</b>
7.5	Electrical Characteristics .....	5	12.1	Layout Guidelines .....	13
7.6	Timing Requirements, $V_{CC} = 3.3\text{ V} \pm 0.3\text{ V}$ .....	5	12.2	Layout Example .....	13
7.7	Timing Requirements, $V_{CC} = 5\text{ V} \pm 0.5\text{ V}$ .....	6	<b>13</b>	<b>Device and Documentation Support</b> .....	<b>13</b>
7.8	Switching Characteristics, $V_{CC} = 3.3\text{ V} \pm 0.3\text{ V}$ .....	6	13.1	Related Links .....	13
7.9	Switching Characteristics, $V_{CC} = 5\text{ V} \pm 0.5\text{ V}$ .....	7	13.2	Trademarks .....	13
7.10	Noise Characteristics .....	7	13.3	Electrostatic Discharge Caution .....	13
7.11	Operating Characteristics .....	7	13.4	Glossary .....	13
7.12	Typical Characteristics .....	8	<b>14</b>	<b>Mechanical, Packaging, and Orderable Information</b> .....	<b>13</b>

## 5 Revision History

### Changes from Revision I (July 2003) to Revision J

Page

• Added <i>Applications</i> , <i>Device Information</i> table, <i>Pin Functions</i> table, <i>ESD Ratings</i> table, <i>Thermal Information</i> table, <i>Typical Characteristics</i> , <i>Feature Description</i> section, <i>Device Functional Modes</i> , <i>Application and Implementation</i> section, <i>Power Supply Recommendations</i> section, <i>Layout</i> section, <i>Device and Documentation Support</i> section, and <i>Mechanical, Packaging, and Orderable Information</i> section. ....	1
• Deleted <i>Ordering Information</i> table. ....	1
• Added Military Disclaimer to <i>Features</i> list. ....	1
• Changed MAX operating temperature to 125°C in <i>Recommended Operating Conditions</i> table. ....	4

## 6 Pin Configuration and Functions

SN54AHC374 . . . J OR W PACKAGE  
SN74AHC374 . . . DB, DGV, DW, N, NS, OR PW PACKAGE  
(TOP VIEW)

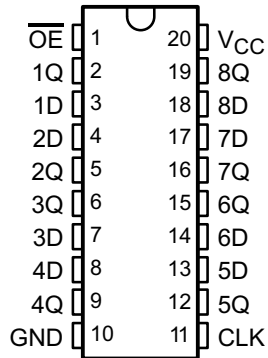

SN54AHC374 . . . FK PACKAGE  
(TOP VIEW)

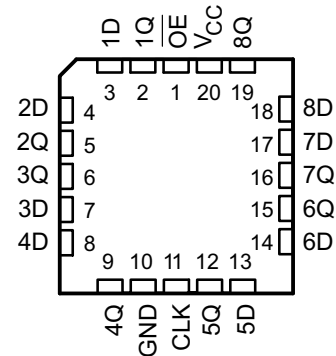

### Pin Functions

PIN		TYPE	DESCRIPTION
NO.	NAME		
1	$\overline{OE}$	I	Output Enable
2	1Q	O	1Q Output
3	1D	I	1D Input
4	2D	I	2D Input
5	2Q	O	2Q Output
6	3Q	O	3Q Output
7	3D	I	3D Input
8	4D	I	4D Input
9	4Q	O	4Q Output
10	GND	—	Ground
11	CLK	I	Clock Pin
12	5Q	O	5Q Output
13	5D	I	5D Input
14	6D	I	6D Input
15	6Q	O	6Q Output
16	7Q	O	7Q Output
17	7D	I	7D Input
18	8D	I	8D Input
19	8Q	O	8Q Output
20	V <sub>CC</sub>	—	Power Pin

## 7 Specifications

### 7.1 Absolute Maximum Ratings<sup>(1)</sup>

over operating free-air temperature range (unless otherwise noted)

		MIN	MAX	UNIT
$V_{CC}$	Supply voltage range	-0.5	7	V
$V_I$	Input voltage range <sup>(2)</sup>	-0.5	7	V
$V_O$	Output voltage range <sup>(2)</sup>	-0.5	$V_{CC} + 0.5$	V
$I_{IK}$	Input clamp current	$V_I < 0$	-20	mA
$I_{OK}$	Output clamp current	$V_O < 0$ or $V_O > V_{CC}$	$\pm 20$	mA
$I_O$	Continuous output current	$V_O = 0$ to $V_{CC}$	$\pm 25$	mA
Continuous current through $V_{CC}$ or GND			$\pm 75$	mA
$T_{stg}$	Storage temperature range	-65	150	°C

- (1) Stresses beyond those listed under *Absolute Maximum Ratings* may cause permanent damage to the device. These are stress ratings only, and functional operation of the device at these or any other conditions beyond those indicated under *Recommended Operating Conditions* is not implied. Exposure to absolute-maximum-rated conditions for extended periods may affect device reliability.
- (2) The input and output voltage ratings may be exceeded if the input and output current ratings are observed.

### 7.2 ESD Ratings

		VALUE	UNIT
$V_{(ESD)}$	Electrostatic discharge		
	Human body model (HBM), per ANSI/ESDA/JEDEC JS-001, all pins <sup>(1)</sup>	2000	V
	Charged device model (CDM), per JEDEC specification JESD22-C101, all pins <sup>(2)</sup>	1500	
Machine Model (MM)	200		

- (1) JEDEC document JEP155 states that 500-V HBM allows safe manufacturing with a standard ESD control process.
- (2) JEDEC document JEP157 states that 250-V CDM allows safe manufacturing with a standard ESD control process.

### 7.3 Recommended Operating Conditions

 over operating free-air temperature range (unless otherwise noted)<sup>(1)</sup>

		SN54AHC374		SN74AHC374		UNIT
		MIN	MAX	MIN	MAX	
$V_{CC}$	Supply voltage	2	5.5	2	5.5	V
$V_{IH}$	High-level input voltage	$V_{CC} = 2$ V	1.5	1.5		V
		$V_{CC} = 3$ V	2.1	2.1		
		$V_{CC} = 5.5$ V	3.85	3.85		
$V_{IL}$	Low-level input voltage	$V_{CC} = 2$ V		0.5	0.5	V
		$V_{CC} = 3$ V		0.9	0.9	
		$V_{CC} = 5.5$ V		1.65	1.65	
$V_I$	Input voltage	0	5.5	0	5.5	V
$V_O$	Output voltage	0	$V_{CC}$	0	$V_{CC}$	V
$I_{OH}$	High-level output current	$V_{CC} = 2$ V		-50	-50	$\mu$ A
		$V_{CC} = 3.3$ V $\pm$ 0.3 V		-4	-4	mA
		$V_{CC} = 5$ V $\pm$ 5.5 V		-8	-8	
$I_{OL}$	Low-level output current	$V_{CC} = 2$ V		50	50	$\mu$ A
		$V_{CC} = 3.3$ V $\pm$ 0.3 V		4	4	mA
		$V_{CC} = 5$ V $\pm$ 5.5 V		8	8	
$\Delta t/\Delta v$	Input transition rise or fall rate	$V_{CC} = 3.3$ V $\pm$ 0.3 V		100	100	ns/V
		$V_{CC} = 5$ V $\pm$ 5.5 V		20	20	
$T_A$	Operating free-air temperature	-55	125	-40	125	°C

- (1) All unused inputs of the device must be held at  $V_{CC}$  or GND to ensure proper device operation. Refer to the TI application report, *Implications of Slow or Floating CMOS Inputs (SCBA004)*.

## 7.4 Thermal Information

THERMAL METRIC <sup>(1)</sup>		SN74AHC374						UNIT
		DB	DGV	DW	N	NS	PW	
		20 PINS						
R <sub>θJA</sub>	Junction-to-ambient thermal resistance	97.9	117.2	79.4	53.3	79.2	103.3	°C/W
R <sub>θJC(top)</sub>	Junction-to-case (top) thermal resistance	59.6	32.7	45.7	40.0	45.7	37.8	
R <sub>θJB</sub>	Junction-to-board thermal resistance	53.1	58.7	46.9	34.2	46.8	54.3	
ψ <sub>JT</sub>	Junction-to-top characterization parameter	21.3	1.15	18.7	26.4	19.3	2.9	
ψ <sub>JB</sub>	Junction-to-board characterization parameter	52.7	58.0	46.5	34.1	46.4	53.8	

(1) For more information about traditional and new thermal metrics, see the *IC Package Thermal Metrics* application report ([SPRA953](#)).

## 7.5 Electrical Characteristics

over recommended operating free-air temperature range (unless otherwise noted)

PARAMETER	TEST CONDITIONS	V <sub>CC</sub>	T <sub>A</sub> = 25°C			SN54AHC374		SN74AHC374				UNIT
						–40°C to 85°C		–40°C to 85°C		–40°C to 125°C		
			MIN	TYP	MAX	MIN	MAX	MIN	MAX	MIN	MAX	
V <sub>OH</sub>	I <sub>OH</sub> = –50 μA	2 V	1.9	2	1.9		1.9		1.9		V	
		3 V	2.9	3	2.9		2.9		2.9			
		4.5 V	4.4	4.5	4.4		4.4		4.4			
	I <sub>OH</sub> = –4 mA	3 V	2.58		2.48		2.48		2.48			
	I <sub>OH</sub> = –8 mA	4.5 V	3.94		3.8		3.8		3.8			
V <sub>OL</sub>	I <sub>OL</sub> = 50 μA	2 V			0.1		0.1		0.1		V	
		3 V			0.1		0.1		0.1			
		4.5 V			0.1		0.1		0.1			
	I <sub>OL</sub> = 4 mA	3 V			0.36		0.5		0.44			
	I <sub>OL</sub> = 8 mA	4.5 V			0.36		0.5		0.44			
I <sub>I</sub>	V <sub>I</sub> = 5.5 V or GND	0 V to 5.5 V			±0.1		±1 <sup>(1)</sup>		±1		μA	
I <sub>OZ</sub>	V <sub>I</sub> = V <sub>IH</sub> or V <sub>IL</sub> V <sub>O</sub> = V <sub>CC</sub> or GND	5.5 V			±0.25		±2.5		±2.5		μA	
I <sub>CC</sub>	V <sub>I</sub> = V <sub>CC</sub> or GND, I <sub>O</sub> = 0	5.5 V			4		40		40		μA	
C <sub>i</sub>	V <sub>I</sub> = V <sub>CC</sub> or GND	5 V			4				10		pF	
C <sub>o</sub>	V <sub>O</sub> = V <sub>CC</sub> or GND	5 V			6						pF	

(1) On products compliant to MIL-PRF-38535, this parameter is not production tested at V<sub>CC</sub> = 0 V.

## 7.6 Timing Requirements, V<sub>CC</sub> = 3.3 V ± 0.3 V

over recommended operating free-air temperature range (unless otherwise noted) (see [Figure 3](#))

PARAMETER	T <sub>A</sub> = 25°C	SN54AHC374		SN74AHC374				UNIT		
				–40°C to 85°C		–40°C to 85°C			–40°C to 125°C	
		MIN	MAX	MIN	MAX	MIN	MAX		MIN	MAX
t <sub>w</sub>	Pulse duration, CLK high or low	5		5.5		5.5		6.5		ns
t <sub>su</sub>	Setup time, data before CLK↑	4.5		4		4		4.5		ns
t <sub>h</sub>	Hold time, data after CLK↑	2		2		2		2.5		ns

## 7.7 Timing Requirements, $V_{CC} = 5\text{ V} \pm 0.5\text{ V}$

 over recommended operating free-air temperature range (unless otherwise noted) (see [Figure 3](#))

PARAMETER		$T_A = 25^\circ\text{C}$		SN54AHC374		SN74AHC374				UNIT
				–40°C to 85°C		–40°C to 85°C		–40°C to 125°C		
		MIN	MAX	MIN	MAX	MIN	MAX	MIN	MAX	
$t_w$	Pulse duration, CLK high or low	5		5		5		5.5		ns
$t_{su}$	Setup time, data before CLK $\uparrow$	3		3		3		3		ns
$t_h$	Hold time, data after CLK $\uparrow$	2		2		2		2		ns

## 7.8 Switching Characteristics, $V_{CC} = 3.3\text{ V} \pm 0.3\text{ V}$

 over recommended operating free-air temperature range (unless otherwise noted) (see [Figure 3](#))

PARAMETER	FROM (INPUT)	TO (OUTPUT)	LOAD CAPACITANCE	$T_A = 25^\circ\text{C}$		SN54AHC374		SN74AHC374				UNIT
						–40°C to 85°C		–40°C to 85°C		–40°C to 125°C		
				MIN	TYP	MAX	MIN	MAX	MIN	MAX	MIN	
$f_{MAX}$			$C_L = 15\text{ pF}$	80 <sup>(1)</sup>	130 <sup>(1)</sup>		70 <sup>(1)</sup>		70		70	MHz
			$C_L = 50\text{ pF}$	55	85		50		50		50	
$t_{PLH}$	CLK	Q	$C_L = 15\text{ pF}$	8.1 <sup>(1)</sup>	12.7 <sup>(1)</sup>	1 <sup>(1)</sup>	15 <sup>(1)</sup>	1	15	1	16.5	ns
$t_{PHL}$				8.1 <sup>(1)</sup>	12.7 <sup>(1)</sup>	1 <sup>(1)</sup>	15 <sup>(1)</sup>	1	15	1	16.5	
$t_{PZH}$	$\overline{OE}$	Q	$C_L = 15\text{ pF}$	7.1 <sup>(1)</sup>	11 <sup>(1)</sup>	1 <sup>(1)</sup>	13 <sup>(1)</sup>	1	13	1	14	ns
$t_{PZL}$				7.1 <sup>(1)</sup>	11 <sup>(1)</sup>	1 <sup>(1)</sup>	13 <sup>(1)</sup>	1	13	1	14	
$t_{PHZ}$	$\overline{OE}$	Q	$C_L = 15\text{ pF}$	7.5 <sup>(1)</sup>	10.5 <sup>(1)</sup>	1 <sup>(1)</sup>	12.5 <sup>(1)</sup>	1	12.5	1	13.5	ns
$t_{PLZ}$				7.5 <sup>(1)</sup>	10.5 <sup>(1)</sup>	1 <sup>(1)</sup>	12.5 <sup>(1)</sup>	1	12.5	1	13.5	
$t_{PLH}$	CLK	Q	$C_L = 50\text{ pF}$	10.6	16.2	1	18.5	1	18.5	1	20	ns
$t_{PHL}$				10.6	16.2	1	18.5	1	18.5	1	20	
$t_{PZH}$	$\overline{OE}$	Q	$C_L = 50\text{ pF}$	9.6	14.5	1	16.5	1	16.5	1	17.5	ns
$t_{PZL}$				9.6	14.5	1	16.5	1	16.5	1	17.5	
$t_{PHZ}$	$\overline{OE}$	Q	$C_L = 50\text{ pF}$	10.2	14	1	16	1	16	1	17	ns
$t_{PLZ}$				10.2	14	1	16	1	16	1	17	
$t_{sk(o)}$			$C_L = 50\text{ pF}$		1.5 <sup>(2)</sup>				1.5		1.5	ns

(1) On products compliant to MIL-PRF-38535, this parameter is not production tested.

(2) On products compliant to MIL-PRF-38535, this parameter does not apply.

## 7.9 Switching Characteristics, $V_{CC} = 5\text{ V} \pm 0.5\text{ V}$

 over recommended operating free-air temperature range (unless otherwise noted) (see [Figure 3](#))

PARAMETER	FROM (INPUT)	TO (OUTPUT)	LOAD CAPACITANCE	$T_A = 25^\circ\text{C}$			SN54AHC374		SN74AHC374				UNIT
							–40°C to 85°C		–40°C to 85°C		–40°C to 125°C		
				MIN	TYP	MAX	MIN	MAX	MIN	MAX	MIN	MAX	
$f_{\text{MAX}}$			$C_L = 15\text{ pF}$	130 <sup>(1)</sup>	185 <sup>(1)</sup>		110 <sup>(1)</sup>		110	110		MHz	
			$C_L = 50\text{ pF}$	85	120		75		75	75			
$t_{\text{PLH}}$	CLK	Q	$C_L = 15\text{ pF}$		5.4 <sup>(1)</sup>	8.1 <sup>(1)</sup>	1 <sup>(1)</sup>	9.5 <sup>(1)</sup>	1	9.5	1	10.5	ns
$t_{\text{PHL}}$					5.4 <sup>(1)</sup>	8.1 <sup>(1)</sup>	1 <sup>(1)</sup>	9.5 <sup>(1)</sup>	1	9.5	1	10.5	
$t_{\text{PZH}}$	$\overline{\text{OE}}$	Q	$C_L = 15\text{ pF}$		5.1 <sup>(1)</sup>	7.6 <sup>(1)</sup>	1 <sup>(1)</sup>	9 <sup>(1)</sup>	1	9	1	10	ns
$t_{\text{PZL}}$					5.1 <sup>(1)</sup>	7.6 <sup>(1)</sup>	1 <sup>(1)</sup>	9 <sup>(1)</sup>	1	9	1	10	
$t_{\text{PHZ}}$	$\overline{\text{OE}}$	Q	$C_L = 15\text{ pF}$		4.6 <sup>(1)</sup>	6.8 <sup>(1)</sup>	1 <sup>(1)</sup>	8 <sup>(1)</sup>	1	8	1	9	ns
$t_{\text{PLZ}}$					4.6 <sup>(1)</sup>	6.8 <sup>(1)</sup>	1 <sup>(1)</sup>	8 <sup>(1)</sup>	1	8	1	9	
$t_{\text{PLH}}$	CLK	Q	$C_L = 50\text{ pF}$		6.9	10.1	1	11.5	1	11.5	1	12.5	ns
$t_{\text{PHL}}$					6.9	10.1	1	11.5	1	11.5	1	12.5	
$t_{\text{PZH}}$	$\overline{\text{OE}}$	Q	$C_L = 50\text{ pF}$		6.6	9.6	1	11	1	11	1	12	ns
$t_{\text{PZL}}$					6.6	9.6	1	11	1	11	1	12	
$t_{\text{PHZ}}$	$\overline{\text{OE}}$	Q	$C_L = 50\text{ pF}$		6.1	8.8	1	10	1	10	1	11	ns
$t_{\text{PLZ}}$					6.1	8.8	1	10	1	10	1	11	
$t_{\text{sk}(o)}$			$C_L = 50\text{ pF}$			1 <sup>(2)</sup>			1		1.5	ns	

(1) On products compliant to MIL-PRF-38535, this parameter is not production tested.

(2) On products compliant to MIL-PRF-38535, this parameter does not apply.

## 7.10 Noise Characteristics

 $V_{CC} = 5\text{ V}$ ,  $C_L = 50\text{ pF}$ ,  $T_A = 25^\circ\text{C}$ <sup>(1)</sup>

PARAMETER		SN74AHC374			UNIT
		MIN	TYP	MAX	
$V_{\text{OL}(P)}$	Quiet output, maximum dynamic $V_{\text{OL}}$		0.5	1	V
$V_{\text{OL}(V)}$	Quiet output, minimum dynamic $V_{\text{OL}}$		–0.5	–0.8	V
$V_{\text{OH}(V)}$	Quiet output, minimum dynamic $V_{\text{OH}}$	4			V
$V_{\text{IH}(D)}$	High-level dynamic input voltage	3.5			V
$V_{\text{IL}(D)}$	Low-level dynamic input voltage			1.5	V

(1) Characteristics are for surface-mount packages only.

## 7.11 Operating Characteristics

 $V_{CC} = 5\text{ V}$ ,  $T_A = 25^\circ\text{C}$ 

PARAMETER	TEST CONDITIONS	TYP	UNIT
$C_{\text{pd}}$	Power dissipation capacitance No load, $f = 1\text{ MHz}$	32	pF

### 7.12 Typical Characteristics

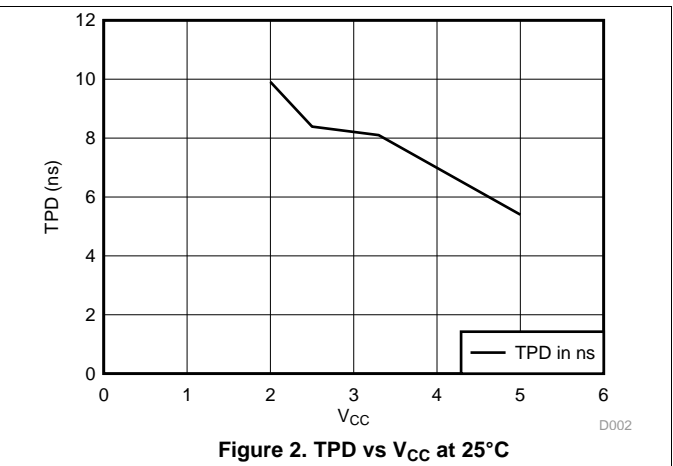
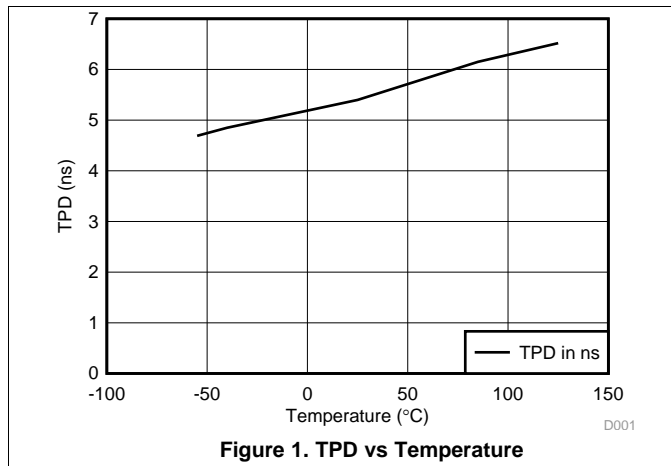

## 8 Parameter Measurement Information

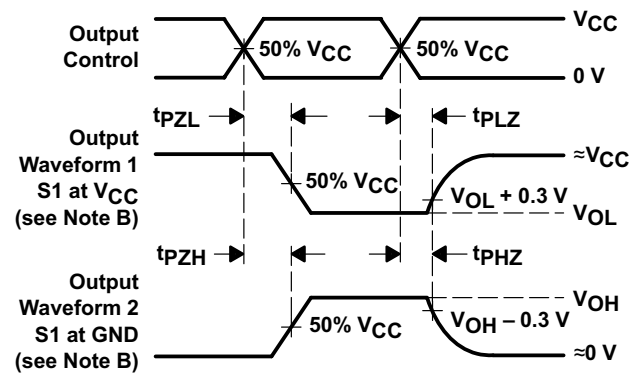
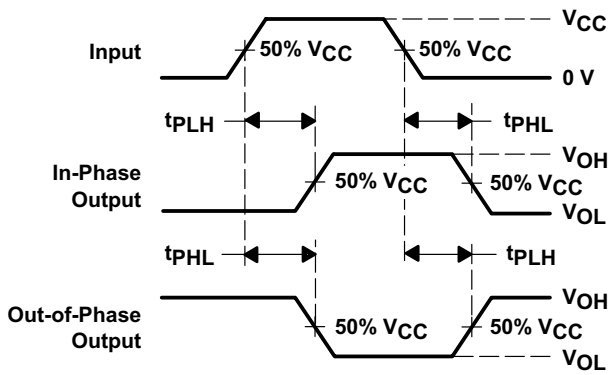
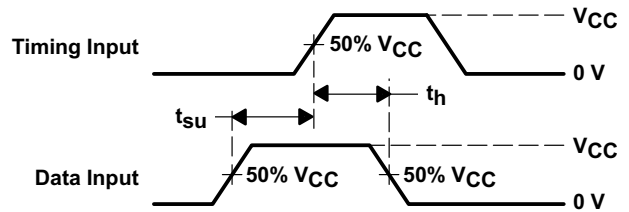
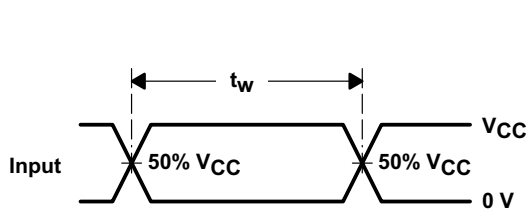
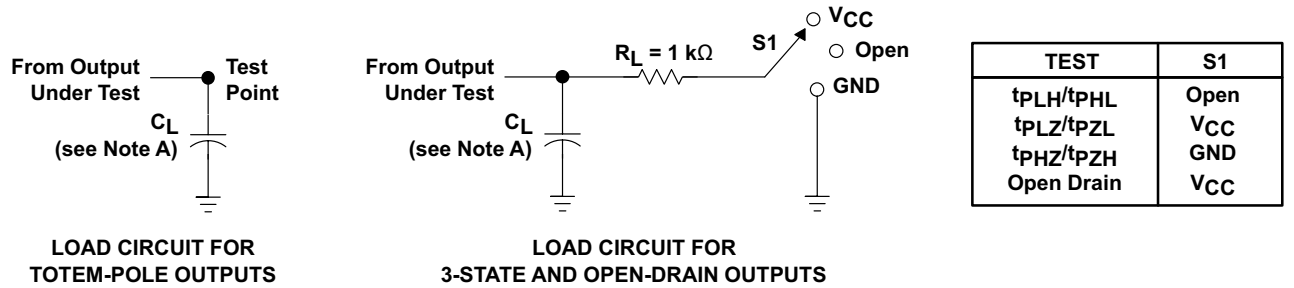

- NOTES: A.  $C_L$  includes probe and jig capacitance.  
 B. Waveform 1 is for an output with internal conditions such that the output is low except when disabled by the output control. Waveform 2 is for an output with internal conditions such that the output is high except when disabled by the output control.  
 C. All input pulses are supplied by generators having the following characteristics:  $PRR \leq 1$  MHz,  $Z_O = 50 \Omega$ ,  $t_r \leq 3$  ns,  $t_f \leq 3$  ns.  
 D. The outputs are measured one at a time with one input transition per measurement.  
 E. All parameters and waveforms are not applicable to all devices.

Figure 3. Load Circuit and Voltage Waveforms

## 9 Detailed Description

### 9.1 Overview

The SNx4AHC374 devices are octal edge-triggered D-type flip-flops that feature 3-state outputs designed specifically for driving highly capacitive or relatively low-impedance loads. These devices are particularly suitable for implementing buffer registers, I/O ports, bidirectional bus drivers, and working registers.

On the positive transition of the clock (CLK) input, the Q outputs are set to the logic levels of the data (D) inputs.

A buffered output-enable ( $\overline{OE}$ ) input can be used to place the eight outputs in either a normal logic state (high or low) or the high-impedance state. In the high-impedance state, the outputs neither load nor drive the bus lines significantly. The high-impedance state and the increased drive provide the capability to drive bus lines without interface or pull-up components.

### 9.2 Functional Block Diagram

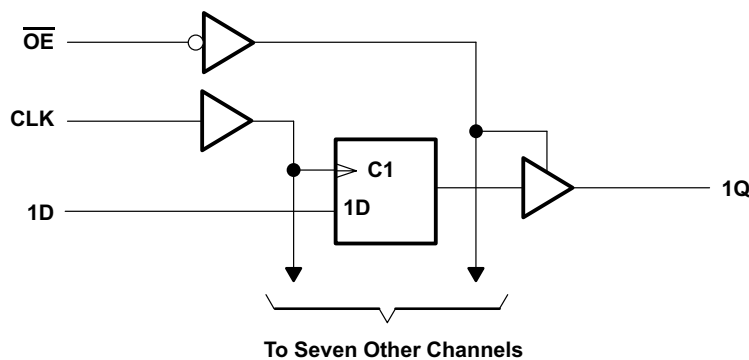

### 9.3 Feature Description

- Wide operating voltage range
  - Operates from 2 V to 5.5 V
- Allows down-voltage translation
  - Inputs accept voltages to 5.5 V
- Slow edges reduce output ringing

### 9.4 Device Functional Modes

**Table 1. Function Table  
(Each Flip-Flop)**

INPUTS			OUTPUT Q
$\overline{OE}$	CLK	D	
L	↑	H	H
L	↑	L	L
L	H or L	X	$Q_0$
H	X	X	Z

## 10 Application and Implementation

### NOTE

Information in the following applications sections is not part of the TI component specification, and TI does not warrant its accuracy or completeness. TI's customers are responsible for determining suitability of components for their purposes. Customers should validate and test their design implementation to confirm system functionality.

### 10.1 Application Information

SNx4AHC374 is a low-drive CMOS device that can be used for a multitude of bus interface type applications where output ringing is a concern. The low drive and slow edge rates will minimize overshoot and undershoot on the outputs. The inputs are tolerant to 5.5 V at any valid  $V_{CC}$ . This feature makes it ideal for translating down to the  $V_{CC}$  level. Figure 5 shows the reduction in ringing compared to higher drive parts such as AC.

### 10.2 Typical Application

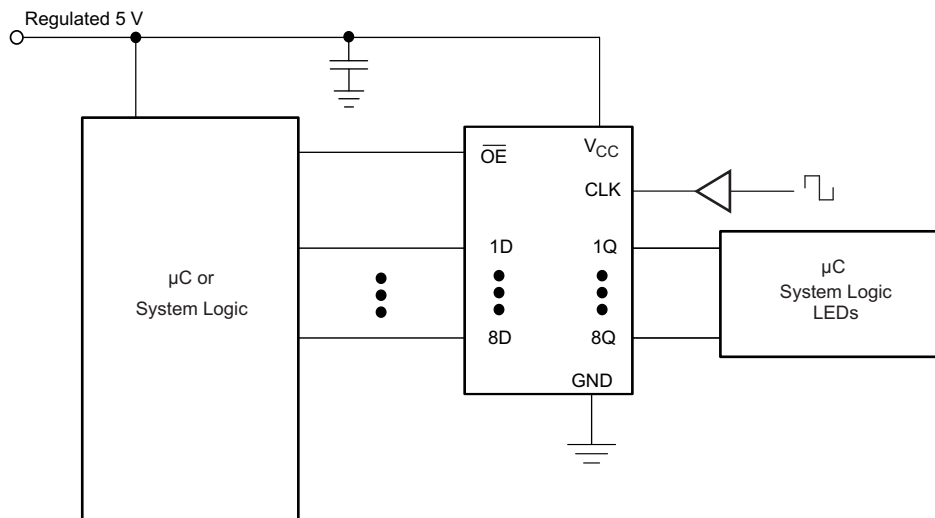

Figure 4. Typical Application Schematic

#### 10.2.1 Design Requirements

This device uses CMOS technology and has balanced output drive. Care should be taken to avoid bus contention because it can drive currents that would exceed maximum limits. The high drive will also create fast edges into light loads, so routing and load conditions should be considered to prevent ringing.

#### 10.2.2 Detailed Design Procedure

1. Recommended Input Conditions
  - For rise time and fall time specifications, see  $\Delta t/\Delta V$  in the [Recommended Operating Conditions](#) table.
  - For specified High and low levels, see  $V_{IH}$  and  $V_{IL}$  in the [Recommended Operating Conditions](#) table.
  - Inputs are overvoltage tolerant allowing them to go as high as 5.5 V at any valid  $V_{CC}$ .
2. Recommend Output Conditions
  - Load currents should not exceed 25 mA per output and 75 mA total for the part.
  - Outputs should not be pulled above  $V_{CC}$ .

## Typical Application (continued)

### 10.2.3 Application Curves

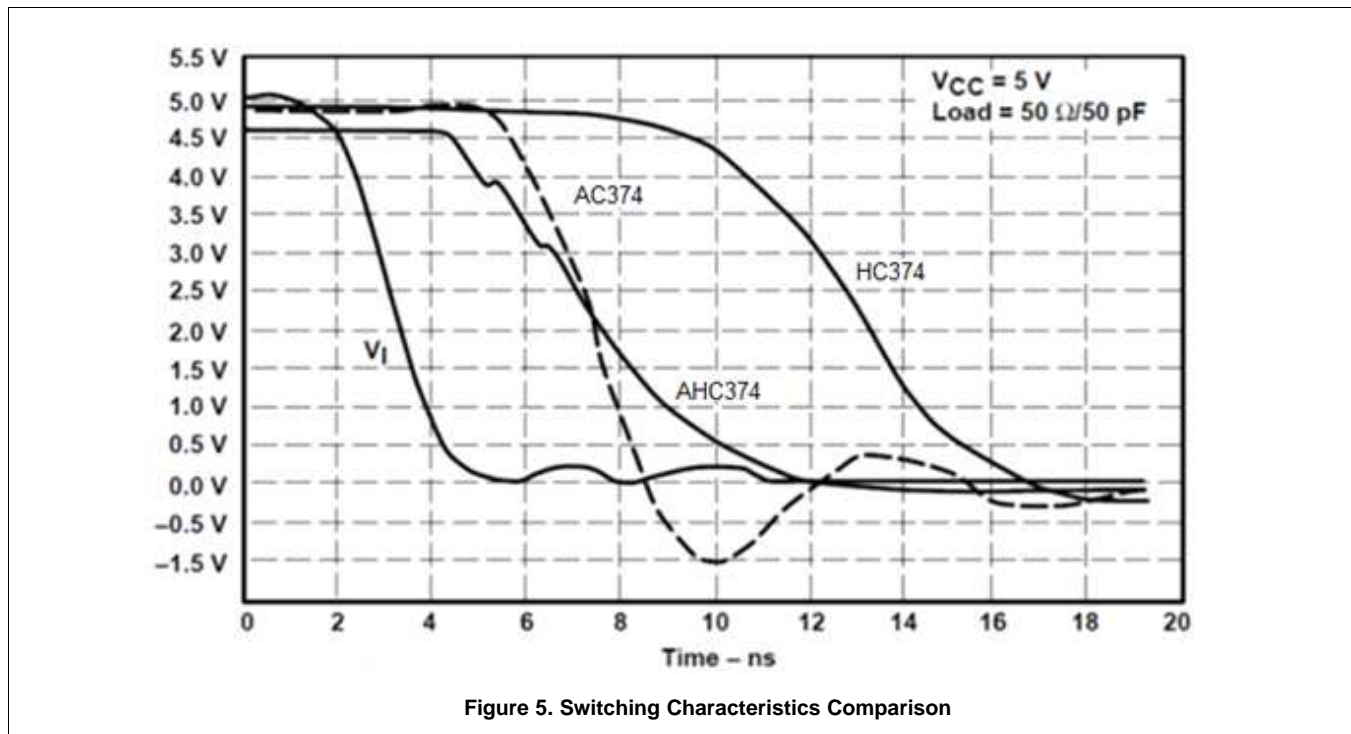

## 11 Power Supply Recommendations

The power supply can be any voltage between the MIN and MAX supply voltage rating located in the [Recommended Operating Conditions](#) table.

Each  $V_{CC}$  pin should have a good bypass capacitor to prevent power disturbance. For devices with a single supply, 0.1  $\mu\text{F}$  is recommended. If there are multiple  $V_{CC}$  pins, 0.01  $\mu\text{F}$  or 0.022  $\mu\text{F}$  is recommended for each power pin. It is acceptable to parallel multiple bypass caps to reject different frequencies of noise. A 0.1  $\mu\text{F}$  and 1  $\mu\text{F}$  are commonly used in parallel. The bypass capacitor should be installed as close to the power pin as possible for best results.

## 12 Layout

### 12.1 Layout Guidelines

When using multiple bit logic devices, inputs should not float. In many cases, functions or parts of functions of digital logic devices are unused. Some examples are when only two inputs of a triple-input AND gate are used, or when only 3 of the 4-buffer gates are used. Such input pins should not be left unconnected because the undefined voltages at the outside connections result in undefined operational states.

Specified in Figure 6 are rules that must be observed under all circumstances. All unused inputs of digital logic devices must be connected to a high or low bias to prevent them from floating. The logic level that should be applied to any particular unused input depends on the function of the device. Generally they will be tied to GND or  $V_{CC}$ , whichever makes more sense or is more convenient. It is acceptable to float outputs unless the part is a transceiver. If the transceiver has an output enable pin, it will disable the outputs section of the part when asserted. This will not disable the input section of the I/Os so they also cannot float when disabled.

### 12.2 Layout Example

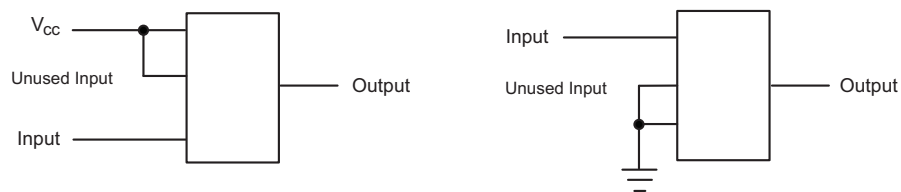

Figure 6. Layout Diagram

## 13 Device and Documentation Support

### 13.1 Related Links

The table below lists quick access links. Categories include technical documents, support and community resources, tools and software, and quick access to sample or buy.

Table 2. Related Links

PARTS	PRODUCT FOLDER	SAMPLE & BUY	TECHNICAL DOCUMENTS	TOOLS & SOFTWARE	SUPPORT & COMMUNITY
SN54AHC374	<a href="#">Click here</a>	<a href="#">Click here</a>	<a href="#">Click here</a>	<a href="#">Click here</a>	<a href="#">Click here</a>
SN74AHC374	<a href="#">Click here</a>	<a href="#">Click here</a>	<a href="#">Click here</a>	<a href="#">Click here</a>	<a href="#">Click here</a>

### 13.2 Trademarks

All trademarks are the property of their respective owners.

### 13.3 Electrostatic Discharge Caution



These devices have limited built-in ESD protection. The leads should be shorted together or the device placed in conductive foam during storage or handling to prevent electrostatic damage to the MOS gates.

### 13.4 Glossary

[SLYZ022](#) — TI Glossary.

This glossary lists and explains terms, acronyms, and definitions.

## 14 Mechanical, Packaging, and Orderable Information

The following pages include mechanical, packaging, and orderable information. This information is the most current data available for the designated devices. This data is subject to change without notice and revision of this document. For browser-based versions of this data sheet, refer to the left-hand navigation.

**PACKAGING INFORMATION**

Orderable Device	Status (1)	Package Type	Package Drawing	Pins	Package Qty	Eco Plan (2)	Lead finish/ Ball material (6)	MSL Peak Temp (3)	Op Temp (°C)	Device Marking (4/5)	Samples
5962-9686401Q2A	ACTIVE	LCCC	FK	20	55	Non-RoHS & Green	SNPB	N / A for Pkg Type	-55 to 125	5962- 9686401Q2A SNJ54AHC 374FK	<a href="#">Samples</a>
5962-9686401QRA	ACTIVE	CDIP	J	20	20	Non-RoHS & Green	SNPB	N / A for Pkg Type	-55 to 125	5962-9686401QR A SNJ54AHC374J	<a href="#">Samples</a>
5962-9686401QSA	ACTIVE	CFP	W	20	25	Non-RoHS & Green	SNPB	N / A for Pkg Type	-55 to 125	5962-9686401QS A SNJ54AHC374W	<a href="#">Samples</a>
SN74AHC374DBR	ACTIVE	SSOP	DB	20	2000	RoHS & Green	NIPDAU	Level-1-260C-UNLIM	-40 to 125	HA374	<a href="#">Samples</a>
SN74AHC374DWR	ACTIVE	SOIC	DW	20	2000	RoHS & Green	NIPDAU	Level-1-260C-UNLIM	-40 to 125	AHC374	<a href="#">Samples</a>
SN74AHC374N	ACTIVE	PDIP	N	20	20	RoHS & Green	NIPDAU	N / A for Pkg Type	-40 to 125	SN74AHC374N	<a href="#">Samples</a>
SN74AHC374NSR	ACTIVE	SO	NS	20	2000	RoHS & Green	NIPDAU	Level-1-260C-UNLIM	-40 to 125	AHC374	<a href="#">Samples</a>
SN74AHC374PWR	ACTIVE	TSSOP	PW	20	2000	RoHS & Green	NIPDAU	Level-1-260C-UNLIM	-40 to 125	HA374	<a href="#">Samples</a>
SN74AHC374PWRG4	ACTIVE	TSSOP	PW	20	2000	RoHS & Green	NIPDAU	Level-1-260C-UNLIM	-40 to 125	HA374	<a href="#">Samples</a>
SNJ54AHC374FK	ACTIVE	LCCC	FK	20	55	Non-RoHS & Green	SNPB	N / A for Pkg Type	-55 to 125	5962- 9686401Q2A SNJ54AHC 374FK	<a href="#">Samples</a>
SNJ54AHC374J	ACTIVE	CDIP	J	20	20	Non-RoHS & Green	SNPB	N / A for Pkg Type	-55 to 125	5962-9686401QR A SNJ54AHC374J	<a href="#">Samples</a>
SNJ54AHC374W	ACTIVE	CFP	W	20	25	Non-RoHS & Green	SNPB	N / A for Pkg Type	-55 to 125	5962-9686401QS A SNJ54AHC374W	<a href="#">Samples</a>

(1) The marketing status values are defined as follows:

**ACTIVE:** Product device recommended for new designs.

**LIFEBUY:** TI has announced that the device will be discontinued, and a lifetime-buy period is in effect.

**NRND:** Not recommended for new designs. Device is in production to support existing customers, but TI does not recommend using this part in a new design.

**PREVIEW:** Device has been announced but is not in production. Samples may or may not be available.

**OBSOLETE:** TI has discontinued the production of the device.

(2) **RoHS:** TI defines "RoHS" to mean semiconductor products that are compliant with the current EU RoHS requirements for all 10 RoHS substances, including the requirement that RoHS substance do not exceed 0.1% by weight in homogeneous materials. Where designed to be soldered at high temperatures, "RoHS" products are suitable for use in specified lead-free processes. TI may reference these types of products as "Pb-Free".

**RoHS Exempt:** TI defines "RoHS Exempt" to mean products that contain lead but are compliant with EU RoHS pursuant to a specific EU RoHS exemption.

**Green:** TI defines "Green" to mean the content of Chlorine (Cl) and Bromine (Br) based flame retardants meet JS709B low halogen requirements of  $\leq 1000$ ppm threshold. Antimony trioxide based flame retardants must also meet the  $\leq 1000$ ppm threshold requirement.

(3) MSL, Peak Temp. - The Moisture Sensitivity Level rating according to the JEDEC industry standard classifications, and peak solder temperature.

(4) There may be additional marking, which relates to the logo, the lot trace code information, or the environmental category on the device.

(5) Multiple Device Markings will be inside parentheses. Only one Device Marking contained in parentheses and separated by a "~" will appear on a device. If a line is indented then it is a continuation of the previous line and the two combined represent the entire Device Marking for that device.

(6) Lead finish/Ball material - Orderable Devices may have multiple material finish options. Finish options are separated by a vertical ruled line. Lead finish/Ball material values may wrap to two lines if the finish value exceeds the maximum column width.

**Important Information and Disclaimer:**The information provided on this page represents TI's knowledge and belief as of the date that it is provided. TI bases its knowledge and belief on information provided by third parties, and makes no representation or warranty as to the accuracy of such information. Efforts are underway to better integrate information from third parties. TI has taken and continues to take reasonable steps to provide representative and accurate information but may not have conducted destructive testing or chemical analysis on incoming materials and chemicals. TI and TI suppliers consider certain information to be proprietary, and thus CAS numbers and other limited information may not be available for release.

In no event shall TI's liability arising out of such information exceed the total purchase price of the TI part(s) at issue in this document sold by TI to Customer on an annual basis.

**OTHER QUALIFIED VERSIONS OF SN54AHC374, SN74AHC374 :**

● Catalog : [SN74AHC374](#)

● Military : [SN54AHC374](#)

NOTE: Qualified Version Definitions:

- Catalog - TI's standard catalog product
- Military - QML certified for Military and Defense Applications

**TAPE AND REEL INFORMATION**

**QUADRANT ASSIGNMENTS FOR PIN 1 ORIENTATION IN TAPE**

\*All dimensions are nominal

Device	Package Type	Package Drawing	Pins	SPQ	Reel Diameter (mm)	Reel Width W1 (mm)	A0 (mm)	B0 (mm)	K0 (mm)	P1 (mm)	W (mm)	Pin1 Quadrant
SN74AHC374DBR	SSOP	DB	20	2000	330.0	16.4	8.2	7.5	2.5	12.0	16.0	Q1
SN74AHC374DWR	SOIC	DW	20	2000	330.0	24.4	10.8	13.3	2.7	12.0	24.0	Q1
SN74AHC374NSR	SO	NS	20	2000	330.0	24.4	8.4	13.0	2.5	12.0	24.0	Q1
SN74AHC374PWR	TSSOP	PW	20	2000	330.0	16.4	6.95	7.1	1.6	8.0	16.0	Q1

## TAPE AND REEL BOX DIMENSIONS



\*All dimensions are nominal

Device	Package Type	Package Drawing	Pins	SPQ	Length (mm)	Width (mm)	Height (mm)
SN74AHC374DBR	SSOP	DB	20	2000	356.0	356.0	35.0
SN74AHC374DWR	SOIC	DW	20	2000	367.0	367.0	45.0
SN74AHC374NSR	SO	NS	20	2000	367.0	367.0	45.0
SN74AHC374PWR	TSSOP	PW	20	2000	356.0	356.0	35.0

**TUBE**

\*All dimensions are nominal

Device	Package Name	Package Type	Pins	SPQ	L (mm)	W (mm)	T (μm)	B (mm)
5962-9686401Q2A	FK	LCCC	20	55	506.98	12.06	2030	NA
5962-9686401QSA	W	CFP	20	25	506.98	26.16	6220	NA
SN74AHC374N	N	PDIP	20	20	506	13.97	11230	4.32
SNJ54AHC374FK	FK	LCCC	20	55	506.98	12.06	2030	NA
SNJ54AHC374W	W	CFP	20	25	506.98	26.16	6220	NA

W (R-GDFP-F20)

CERAMIC DUAL FLATPACK

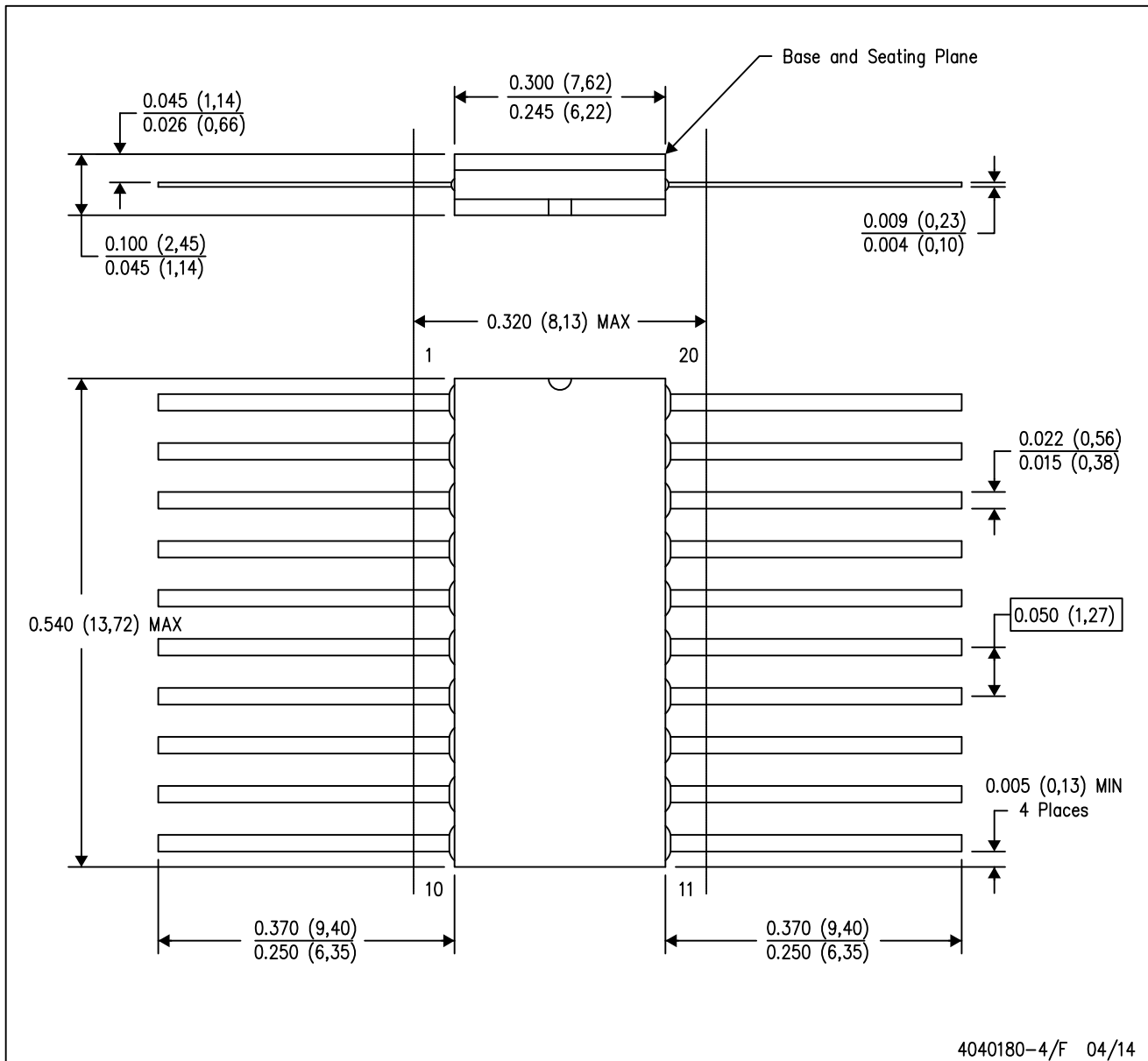

- NOTES:
- All linear dimensions are in inches (millimeters).
  - This drawing is subject to change without notice.
  - This package can be hermetically sealed with a ceramic lid using glass frit.
  - Index point is provided on cap for terminal identification only.
  - Falls within Mil-Std 1835 GDFP2-F20



# EXAMPLE BOARD LAYOUT

PW0020A

TSSOP - 1.2 mm max height

SMALL OUTLINE PACKAGE



LAND PATTERN EXAMPLE  
EXPOSED METAL SHOWN  
SCALE: 10X



SOLDER MASK DETAILS

4220206/A 02/2017

NOTES: (continued)

- 6. Publication IPC-7351 may have alternate designs.
- 7. Solder mask tolerances between and around signal pads can vary based on board fabrication site.

# EXAMPLE STENCIL DESIGN

PW0020A

TSSOP - 1.2 mm max height

SMALL OUTLINE PACKAGE



SOLDER PASTE EXAMPLE  
BASED ON 0.125 mm THICK STENCIL  
SCALE: 10X

4220206/A 02/2017

NOTES: (continued)

8. Laser cutting apertures with trapezoidal walls and rounded corners may offer better paste release. IPC-7525 may have alternate design recommendations.
9. Board assembly site may have different recommendations for stencil design.

PW (R-PDSO-G20)

PLASTIC SMALL OUTLINE



- NOTES:
- A. All linear dimensions are in millimeters.
  - B. This drawing is subject to change without notice.
  - C. Publication IPC-7351 is recommended for alternate design.
  - D. Laser cutting apertures with trapezoidal walls and also rounding corners will offer better paste release. Customers should contact their board assembly site for stencil design recommendations. Refer to IPC-7525 for other stencil recommendations.
  - E. Customers should contact their board fabrication site for solder mask tolerances between and around signal pads.

# DB0020A



# PACKAGE OUTLINE

## SSOP - 2 mm max height

SMALL OUTLINE PACKAGE



4214851/B 08/2019

### NOTES:

- All linear dimensions are in millimeters. Any dimensions in parenthesis are for reference only. Dimensioning and tolerancing per ASME Y14.5M.
- This drawing is subject to change without notice.
- This dimension does not include mold flash, protrusions, or gate burrs. Mold flash, protrusions, or gate burrs shall not exceed 0.15 mm per side.
- This dimension does not include interlead flash. Interlead flash shall not exceed 0.25 mm per side.
- Reference JEDEC registration MO-150.

# EXAMPLE BOARD LAYOUT

DB0020A

SSOP - 2 mm max height

SMALL OUTLINE PACKAGE



LAND PATTERN EXAMPLE  
EXPOSED METAL SHOWN  
SCALE: 10X

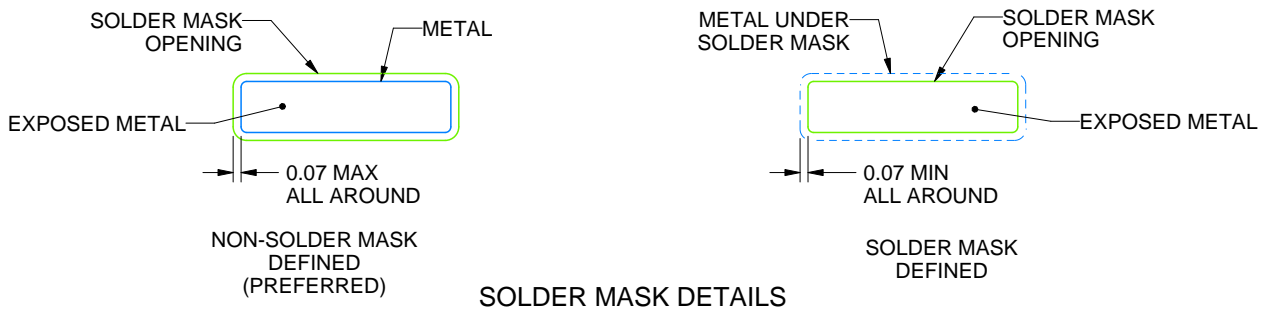

4214851/B 08/2019

NOTES: (continued)

- 6. Publication IPC-7351 may have alternate designs.
- 7. Solder mask tolerances between and around signal pads can vary based on board fabrication site.

# EXAMPLE STENCIL DESIGN

DB0020A

SSOP - 2 mm max height

SMALL OUTLINE PACKAGE



SOLDER PASTE EXAMPLE  
BASED ON 0.125 mm THICK STENCIL  
SCALE: 10X

4214851/B 08/2019

NOTES: (continued)

8. Laser cutting apertures with trapezoidal walls and rounded corners may offer better paste release. IPC-7525 may have alternate design recommendations.
9. Board assembly site may have different recommendations for stencil design.

# MECHANICAL DATA

NS (R-PDSO-G\*\*)

PLASTIC SMALL-OUTLINE PACKAGE

14-PINS SHOWN



- NOTES:
- All linear dimensions are in millimeters.
  - This drawing is subject to change without notice.
  - Body dimensions do not include mold flash or protrusion, not to exceed 0,15.

J (R-GDIP-T\*\*)

14 LEADS SHOWN

CERAMIC DUAL IN-LINE PACKAGE



DIM \ PINS **	14	16	18	20
A	0.300 (7,62) BSC	0.300 (7,62) BSC	0.300 (7,62) BSC	0.300 (7,62) BSC
B MAX	0.785 (19,94)	.840 (21,34)	0.960 (24,38)	1.060 (26,92)
B MIN	—	—	—	—
C MAX	0.300 (7,62)	0.300 (7,62)	0.310 (7,87)	0.300 (7,62)
C MIN	0.245 (6,22)	0.245 (6,22)	0.220 (5,59)	0.245 (6,22)



4040083/F 03/03

- NOTES:
- All linear dimensions are in inches (millimeters).
  - This drawing is subject to change without notice.
  - This package is hermetically sealed with a ceramic lid using glass frit.
  - Index point is provided on cap for terminal identification only on press ceramic glass frit seal only.
  - Falls within MIL STD 1835 GDIP1-T14, GDIP1-T16, GDIP1-T18 and GDIP1-T20.

## GENERIC PACKAGE VIEW

**FK 20**

**LCCC - 2.03 mm max height**

8.89 x 8.89, 1.27 mm pitch

LEADLESS CERAMIC CHIP CARRIER

This image is a representation of the package family, actual package may vary.  
Refer to the product data sheet for package details.



4229370VA\

N (R-PDIP-T\*\*)

PLASTIC DUAL-IN-LINE PACKAGE

16 PINS SHOWN



- NOTES:
- A. All linear dimensions are in inches (millimeters).
  - B. This drawing is subject to change without notice.
  - Falls within JEDEC MS-001, except 18 and 20 pin minimum body length (Dim A).
  - The 20 pin end lead shoulder width is a vendor option, either half or full width.

# DW0020A



# PACKAGE OUTLINE

## SOIC - 2.65 mm max height

SOIC



4220724/A 05/2016

### NOTES:

1. All linear dimensions are in millimeters. Dimensions in parenthesis are for reference only. Dimensioning and tolerancing per ASME Y14.5M.
2. This drawing is subject to change without notice.
3. This dimension does not include mold flash, protrusions, or gate burrs. Mold flash, protrusions, or gate burrs shall not exceed 0.15 mm per side.
4. This dimension does not include interlead flash. Interlead flash shall not exceed 0.43 mm per side.
5. Reference JEDEC registration MS-013.

# EXAMPLE BOARD LAYOUT

DW0020A

SOIC - 2.65 mm max height

SOIC



LAND PATTERN EXAMPLE  
SCALE:6X



SOLDER MASK DETAILS

4220724/A 05/2016

NOTES: (continued)

- 6. Publication IPC-7351 may have alternate designs.
- 7. Solder mask tolerances between and around signal pads can vary based on board fabrication site.

# EXAMPLE STENCIL DESIGN

DW0020A

SOIC - 2.65 mm max height

SOIC

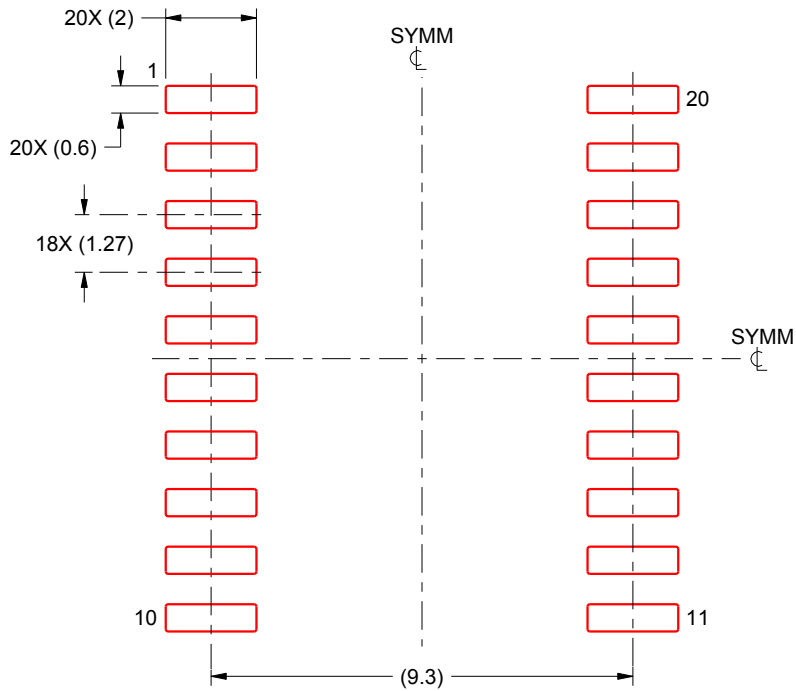

SOLDER PASTE EXAMPLE  
BASED ON 0.125 mm THICK STENCIL  
SCALE:6X

4220724/A 05/2016

NOTES: (continued)

8. Laser cutting apertures with trapezoidal walls and rounded corners may offer better paste release. IPC-7525 may have alternate design recommendations.
9. Board assembly site may have different recommendations for stencil design.

## IMPORTANT NOTICE AND DISCLAIMER

TI PROVIDES TECHNICAL AND RELIABILITY DATA (INCLUDING DATA SHEETS), DESIGN RESOURCES (INCLUDING REFERENCE DESIGNS), APPLICATION OR OTHER DESIGN ADVICE, WEB TOOLS, SAFETY INFORMATION, AND OTHER RESOURCES "AS IS" AND WITH ALL FAULTS, AND DISCLAIMS ALL WARRANTIES, EXPRESS AND IMPLIED, INCLUDING WITHOUT LIMITATION ANY IMPLIED WARRANTIES OF MERCHANTABILITY, FITNESS FOR A PARTICULAR PURPOSE OR NON-INFRINGEMENT OF THIRD PARTY INTELLECTUAL PROPERTY RIGHTS.

These resources are intended for skilled developers designing with TI products. You are solely responsible for (1) selecting the appropriate TI products for your application, (2) designing, validating and testing your application, and (3) ensuring your application meets applicable standards, and any other safety, security, regulatory or other requirements.

These resources are subject to change without notice. TI grants you permission to use these resources only for development of an application that uses the TI products described in the resource. Other reproduction and display of these resources is prohibited. No license is granted to any other TI intellectual property right or to any third party intellectual property right. TI disclaims responsibility for, and you will fully indemnify TI and its representatives against, any claims, damages, costs, losses, and liabilities arising out of your use of these resources.

TI's products are provided subject to [TI's Terms of Sale](#) or other applicable terms available either on [ti.com](https://www.ti.com) or provided in conjunction with such TI products. TI's provision of these resources does not expand or otherwise alter TI's applicable warranties or warranty disclaimers for TI products.

TI objects to and rejects any additional or different terms you may have proposed.

Mailing Address: Texas Instruments, Post Office Box 655303, Dallas, Texas 75265  
Copyright © 2024, Texas Instruments Incorporated

## Looking for pricing, stock, or lifecycle information?

Click below to explore more details on WIN SOURCE:

 [View SN74AHC374NSR on WIN SOURCE](#)

 [Texas Instruments](#) Information

## Optimize Your Supply Chain with WIN SOURCE Solutions

-  Global Sourcing Solution
-  Obsolete Management
-  Cost Control Management
-  Shortage Management
-  Alternative Solution
-  Excess Inventory Management